

Revised

Received by GSTI

DEC 11 1989

Status of the ETA-II Linear Induction Accelerator--High Brightness Results

W. C. Turner, J. K. Boyd
J. C. Clark, and W. E. Nexsen

Prepared for presentation at the
1989 Particle Accelerator
Conference
Chicago, Illinois

March 20-23, 1989

Beam Research Program

Lawrence Livermore National Laboratory

This is a preprint of a paper intended for publication in a journal or proceedings. Since changes may be made before publication, this preprint is made available with the understanding that it will not be cited or reproduced without the permission of the author.

DISCLAIMER

This report was prepared as an account of work sponsored by an agency of the United States Government. Neither the United States Government nor any agency thereof, nor any of their employees, makes any warranty, express or implied, or assumes any legal liability or responsibility for the accuracy, completeness, or usefulness of any information, apparatus, product, or process disclosed, or represents that its use would not infringe privately owned rights. Reference herein to any specific commercial product, process, or service by trade name, trademark, manufacturer, or otherwise does not necessarily constitute or imply its endorsement, recommendation, or favoring by the United States Government or any agency thereof. The views and opinions of authors expressed herein do not necessarily state or reflect those of the United States Government or any agency thereof.

DISCLAIMER

Portions of this document may be illegible in electronic image products. Images are produced from the best available original document.

Disclaimer

This document was prepared as an account of work sponsored by an agency of the United States Government. Neither the United States Government or the University of California nor any of their employees makes any warranty, expressed or implied, or assumes any legal liability or responsibility for the accuracy, completeness, or usefulness of any information, apparatus, product, or process disclosed, or represents that its use would not infringe privately owned rights. Reference herein to any specific commercial products, process, or service by trade name, trademark, manufacturer, or otherwise, does not necessarily constitute or imply its endorsement, recommendation, or favoring by the United States Government or the University of California. The views and opinions of authors expressed herein do not necessarily state or reflect those of the United States Government or the University of California, and shall not be used for advertising or product endorsement purposes.

STATUS OF THE ETA-II LINEAR INDUCTION ACCELERATOR:
HIGH BRIGHTNESS RESULTS*

W. C. Turner, J. K. Boyd, J. C. Clark, and W. E. Nexsen

Lawrence Livermore National Laboratory
P. O. Box 808, L-626
Livermore, California 94550

UCRL--99579-Rev.

Abstract

DE90 003600

A two-aperture collimator has been used to measure brightness of the electron beam produced by the injector and the first 20 acceleration cells of the ETA-II linear induction accelerator. Osmium alloy dispenser cathodes produce the electron beam. For accelerated currents up to 1.5 kA with 2.0- to 2.7-MeV beam energies the measured brightness is $5 \times 10^9 \text{ A}/(\text{rad}\cdot\text{m})^2$, exceeding our design goal by a factor of 2. At the highest current, 2.0 kA, a beam brightness of $2.6 \times 10^9 \text{ A}/(\text{rad}\cdot\text{m})^2$ has been measured.

Introduction

The Experimental Test Accelerator II (ETA-II) accelerator is the latest in a series of linear induction electron accelerators built at the Lawrence Livermore National Laboratory. The initial objectives of the ETA-II experimental program are to create high-brightness and high-average-power electron beams. Both parameters are related to the usefulness of the induction accelerator as a driver for a short-wavelength, high-average-power free-electron laser (FEL). Design parameters for ETA-II are 10-MeV beam energy, 3-kA current, 50-ns pulse flat top, and 5-kHz repetition rate. The

MASTER

*Performed jointly under the auspices of the U. S. DOE by LLNL under W-7405-ENG-48 and for the DOD under SDIO/SDC-ATC MIPR No. W31RPD8D5005.

accelerator consists of a nine induction cell injector, sixty induction accelerator cells, and four magnetic compression pulse-power modulators. The emphasis in this paper is on measurements of beam brightness. The experiments were done at low repetition rate with the injector plus the first 20 acceleration cells. Beam energy was typically 2.5 MeV, current up to 2 kA, and repetition rate 1 to 3 Hz. Descriptions of ETA-II are given elsewhere.^{1,2}

Description of the Experiment

The choice of cathode and the electron optics design of the electrode shapes in the extraction region of the injector are crucial for obtaining high and uniform current density and for minimizing the transverse phase space volume of the electron beam. For the experiments reported here, we use thermionic, osmium-coated dispenser cathodes. Previous experiments have shown the intrinsic brightness of this type of cathode to exceed 1.2×10^{10} A/(rad-m)² up to current densities of 140 A/cm²; the current density and brightness are uniform to within $\pm 10\%$ over the cathode area.³ Diagrams of the ETA-II cathodes and extraction electrode shapes are shown in Fig. 1. The extraction geometry consists of a curved cathode surrounded by a non-emitting focusing electrode, and intermediate electrode, and the anode pipe through which the beam is extracted. The cathode is mounted on the end of a stalk inserted through the bore of five induction cells, while the anode pipe is inserted from the opposite direction through four additional induction cells. Solenoidal coils incorporated into the anode induction cells focus the beam inside the anode pipe. Axial magnetic field strength is typically 0.5 to 1.0 kG. The cathode is designed to be operated with nearly zero magnetic

field component normal to its surface in order to minimize the canonical angular momentum of the extracted electron beam. This is accomplished with two coils placed over the cathode-anode region on the outside of the vacuum chamber. Current in these coils opposes the focusing field in the anode pipe and is adjusted to null the normal magnetic field component on the cathode surface. The electrode shapes and relative locations have been designed with the DPC particle code.⁴ For a cathode to anode voltage of 1.5 MV the DPC code predicts a space-charge-limited current of 2140 A for the 8.9-cm-diam cathode of Fig. 1(a) and of 3126 A for the 12.7-cm-diam cathode of Fig. 1(b).

For the experiments reported below, the brightness of the electron beam is measured with a field-free, two-aperture collimator, which is shown schematically in Fig. 2. A sine/cosine coil pair between the collimator apertures corrects for misalignment between the collimator and beam axes. A pair of solenoidal coils at the end of ETA-II and 70 cm in front of the first aperture of the collimator is used to focus the beam to a waist halfway between the two apertures. Experimentally, this is done by adjusting the strength of the solenoidal lens to maximize current through the second aperture. The apertures are holes with radius $a = 1.5$ mm drilled through range-thick 3.8-cm graphite disks and separated by a distance $L = 61.6$ cm. A gated image intensifier CCD camera is used to observe the beam image on the first aperture. The image is typically about 1 cm in diameter. Steering coils (also sine/cosine wound) over the focus solenoids direct the beam onto the first aperture. Resistive foil-wall return-current monitors measure the beam current before and after each aperture. Referring to Fig. 2 we define I_1 as the current that exits the accelerator and falls on the first aperture, I_2 as the current through the first and incident on the second

aperture, and I_3 as the current through the second aperture. The (normalized) beam brightness is defined by

$$J = \frac{1}{(\beta\gamma)^2} \frac{I_3}{V_4} \frac{1}{\delta}$$

where $\beta\gamma$ is the usual relativistic factor, $V_4 = \pi^2 \alpha^4 / L^2 = 1.32 \times 10^{-10} \text{ (rad-m)}^2$ is the transverse four-dimensional phase space acceptance defined by the collimator, and $\delta = \delta(\beta\gamma, I_2/I_A, I_3/I_2, \alpha/L) < 1$ is a space-charge correction factor. The beam energy, and therefore $\beta\gamma$, is calculated from capacitance probe monitors of voltage applied to the induction cell gaps. The space-charge correction factor accounts for the reduction of phase space acceptance due to space-charge spreading of the beam. For this correction we use a formula derived by Caporaso,⁶ which gives an upper bound on δ and therefore a lower bound on the beam brightness estimated from I_3 .

Attention to vacuum quality is very important for obtaining the results reported in this paper since the osmium-coated dispenser cathode can be easily poisoned by too high a partial pressure of electronegative compounds such as water vapor, oxygen, and fluorocarbons. The basic requirement is that the desired space-charge-limited current density (10 to 20 A/cm²) be achieved at a temperature low enough to ensure stable cathode operation for the time required to obtain the data (approximately twenty operating days for measurements with a given cathode). It has previously been shown that a leak-tight, unbaked vacuum system with O-ring seals and base pressure $P < 1 \times 10^{-7}$ Torr is adequate to meet this requirement.³ In this case the

base vacuum pressure consisted mostly of water vapor and residual amounts of methane, carbon monoxide, and their fragments. Although by modern standards this pressure is not too difficult to achieve some attention has to be taken to avoid the sometimes disappointing results obtained with this type of cathode in accelerator environments. For the experiments reported here we avoided materials that contribute high water vapor pressure (i.e., plastic insulators), chose an O-ring (Viton) and dielectric insulation fluid (FC-75 Fluorinert) combination that limits permeation of dielectric fluid into the high vacuum region to very low levels, and also ensured that there were no detectable atmospheric leaks before operating the cathode. Once this was achieved the background pressure-- $p = 5 \times 10^{-8}$ Torr with the cathode hot--was routinely obtained, and there have been no indications of cathode deterioration for the duration of our experiments. This vacuum pressure is maintained with two turbomolecular and two cryo pumps mounted over the cathode region of the injector. No high temperature bakeout is required, and all vacuum seals are standard O-rings.

Experimental Results

As a check of basic cathode operation we have measured cathode emission current versus temperature for fixed injector voltage. Cathode temperature is measured with an optical pyrometer and quoted as a brightness temperature ($^{\circ}C_B$) uncorrected for emissivity of the cathode surface. Temperature varies significantly over the cathode surface: the coolest region is at the center, while the hottest regions are near the outside of the cathode and directly over the spiral-wound heater filament embedded in the back of the cathode. In this paper we always refer to temperature at the cathode center. At

1000°C_B the temperature differential between hottest and coolest region of the cathode surface is 60°C_B (16°C_B) for the 8.9-cm (12.7 cm) diameter cathode. Heater power required to maintain the cathodes at 1000°C_B is 1078 W (17.3 W/cm²) for the 8.9-cm-diam cathode and 1414 W (11.2W/cm²) for the 12.7-cm-diam cathode. Emission current versus temperature is shown in Fig. 3 for the 8.9- and 12.7-cm-diam cathodes. For these two cathodes, the injector voltage was 0.9 and 1.2 MV, respectively, at saturation. Both sets of data show a sharp knee at the transition from emission to space-charge-limited operation. The transition temperature is low enough to ensure very long cathode lifetime in space-charge-limited operation. The larger cathode seems to be superior since, for the data in Fig. 3, the transition occurs at lower temperature (970°C_B versus 1090°C_B) even though the saturated current density is somewhat higher (15.8 A/cm² versus 12.9 A/cm²). Application of Richardson's law gives a work function for the 12.7-cm-diam cathode that is 0.2 eV lower than for the 8.9-cm-diam cathode. For measurements of beam brightness we always operate the cathodes in the space-charge-limited region.

In Fig. 4 we show a plot of injector current versus voltage for the 8.9-cm-diam cathode with all data points space charge limited. Relativistic corrections to Child's law are small up to the maximum applied voltage, so the data are in good agreement with a three-halves power law $I \sim V^{3/2}$. The experimental data in Fig. 4 and similar data for the 12.7-cm-diam cathode fall ~15-20% below the DPC predicted current for a given applied voltage.

Electron beam brightness data obtained with the apparatus shown schematically in Fig. 2 are summarized in Tables 1 and 2 for the 8.9- and 12.7-cm-diam cathodes. Brightness is given in the far right-hand column,

while beam energy, beam current (I_1 in Fig. 1), currents exiting the first (I_2) and second (I_3) apertures of the collimator, and the space charge correction factor δ are given in the other columns. For both cathodes, data were taken for a range of beam currents and over several run days with slightly different beam transport conditions to verify the reproducibility of the data. For the 8.9-cm-diam cathode, the brightness $J = 4 \times 10^9$ A/(rad-m)² is essentially constant within experimental error with beam current varying from 0.85 kA to 1.4 kA. At 1.5 kA, the 12.7-cm-diam cathode has a similar brightness [5×10^9 A/(rad-m)²], but at higher currents the brightness values recorded are somewhat reduced: at 1.7 kA, $J = 1.7 \times 10^9$ A/(rad-m)², and at 2.0 kA, $J = 3.2 \times 10^9$ A/(rad-m)². Whether this decrease in brightness is a real trend or an artifact of less than optimum tuning of the accelerator is unknown at present.

With the large currents being accelerated in these experiments and the relatively low beam energy, beam transport is dominated by the space charge of the beam rather than by beam emittance. To measure beam brightness with the two-hole collimation scheme and avoid being overwhelmed by space charge it is necessary to use small apertures and sample a relatively small fraction of the total beam current. The question naturally arises whether the brightness values obtained are representative of the whole beam. Earlier measurements of the intrinsic cathode brightness³ and the DPC simulation results support the notion that beam brightness is uniform. In principle, one could scan the beam across the collimator to obtain a brightness profile, but in practice this method has been impractical because of the spatial beam sweep induced by energy variation and because of the time needed to tune the accelerator for a given data point. Reducing the energy variation of the beam to $\pm 1\%$ for a

50-ns flat top is one of the primary goals of the ongoing experimental program. In addition, after repeating these measurements with the full 60 accelerator cells, we plan to measure the total beam brightness with either the pepper pot method used to study the intrinsic cathode brightness³ or a collimator with superimposed axial magnetic field.

For the bulk of the data in Tables 1 and 2, beam transport calculations with experimentally measured values of current in the solenoidal focusing magnets predict envelope oscillations with roughly 2:1 ratio because of mismatch. At present, we do not have diagnostic capability to measure these oscillations. One attempt (on 1/31/89 in Table 2) was made to eliminate them by using a set of focusing currents that, in theory, had very small envelope oscillations. Although the result obtained, $J = 3.2 \times 10^9 \text{ A}/(\text{rad-m})^2$ at $I = 1.14 \text{ kA}$, is respectable, it is not quite as good as earlier data.

Discussion

In Fig. 5 we plot brightness versus current for the ETA-II data included in Tables 1 and 2 together with measurements of the intrinsic brightness previously measured for a dispenser cathode. For currents of 1.5 kA or less the ETA-II brightness measured with the two-aperture collimator is $4 \times 10^9 \text{ A}/(\text{rad-m})^2$. To our knowledge this brightness is the highest recorded in an induction accelerator, and it has been obtained at a current that is very reasonable for a high power FEL. This brightness value exceeds our original design goal by a factor of 2, and, if maintained during acceleration to the final beam energy required by the FEL resonance condition, is sufficient for efficient production of an FEL beam with a wavelength of less than $1 \mu\text{m}$.

Referring to Fig. 5 the measured ETA-II brightness is about a factor of 3 less than the brightness measured for a dispenser cathode in simple plane geometry without beam extraction. The code calculations suggest that some degradation of brightness occurs in the extraction region because of nonlinear forces on the electron beam as it enters the anode pipe. However, the code also predicts brightness about a factor of 2 higher than that experimentally observed. Perhaps some of this discrepancy can be explained by the fact that our measurement can be viewed as a lower bound due to several effects: first, the space charge correction itself is a lower bound; second, it is possible that we have not found the best accelerator conditions for transporting the beam through the two apertures of the collimator; and finally, the results may be limited by energy sweep of the beam across the collimator, which often results in rather narrow peaked signals being recorded.

References

1. D.S. Prono, et al., "Engineering Aspects and Initial Performance of ETA-II," in Proc. Beams '88--7th Int'l Conf. High Power Particle Beams, Karlsruhe, Germany, July 4-8, 1988, Vol. 1, p. 214.
2. J.C. Clark, et al., "Design and Initial Operation of the ETA-II Induction Accelerator," in Proc. Linac 88 Linear Accelerator Conf., Williamsburg, VA, October 2-7, 1988; also published as LLNL report UCRL-99201.
3. W.C. Turner, et al., "High-Brightness, High-Current Density Cathode for Induction Linac FELs," in Proc. Linac 88 Linear Accelerator Conf., Williamsburg, VA, Oct. 2-7, 1988; also published as LLNL report UCRL-99042.
4. J.K. Boyd, et al., IEEE Trans. Nuc. Sci. NS-32 (5), Oct., 1985, p. 2602.
5. C. Lejeune and J. Aubert, in Applied Charged Particle Optics, A. Septier, Ed. (Academic Press, New York, 1980), Part A, 159-259.
6. G.J. Caporaso, The Effects of Space Charge on the Acceptance of Brightness Measuring Devices, LLNL report UCID-20527 (1985).

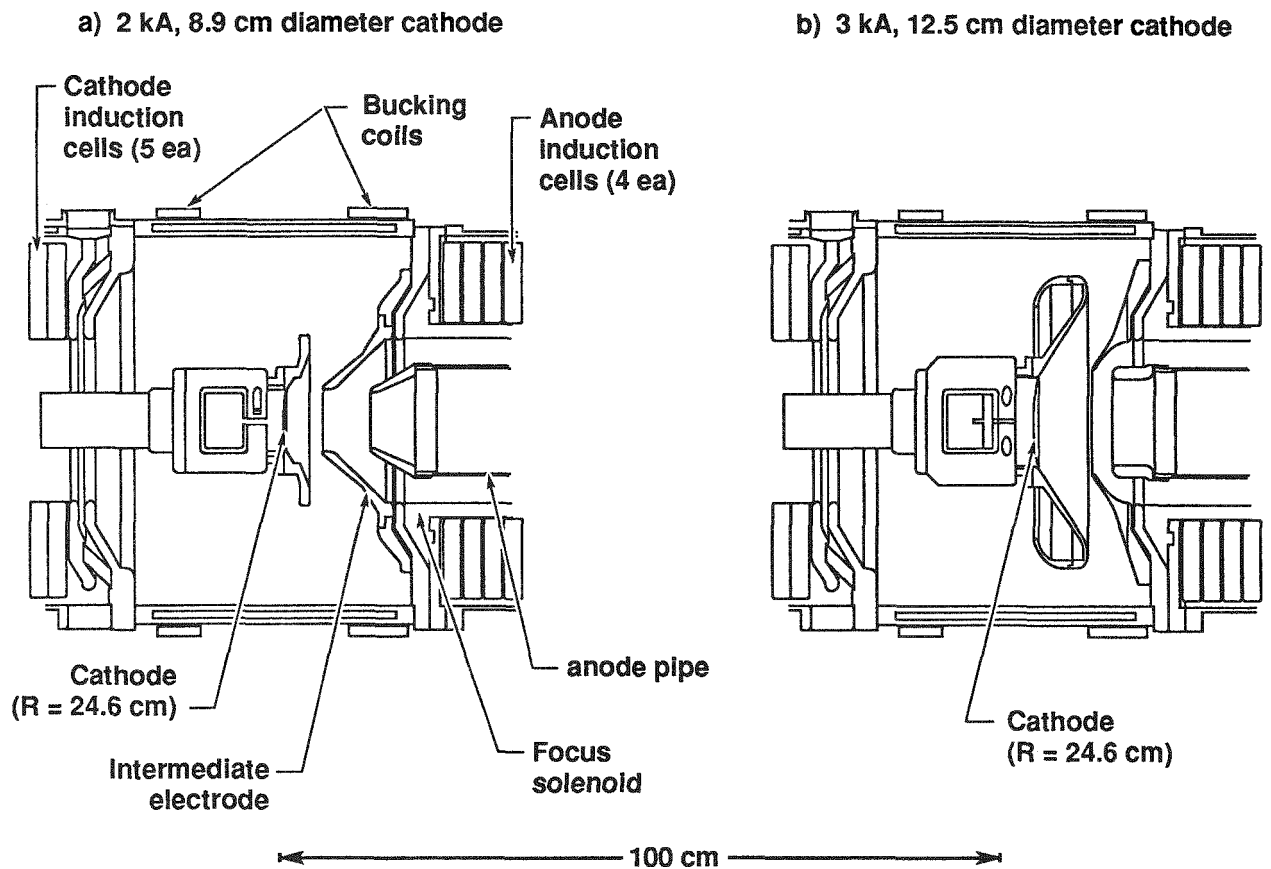

Figure 1. Diagrams of the cathode-anode region of the injector for the (a) 8.9-cm-diam and (b) 12.7-cm-diam cathodes.

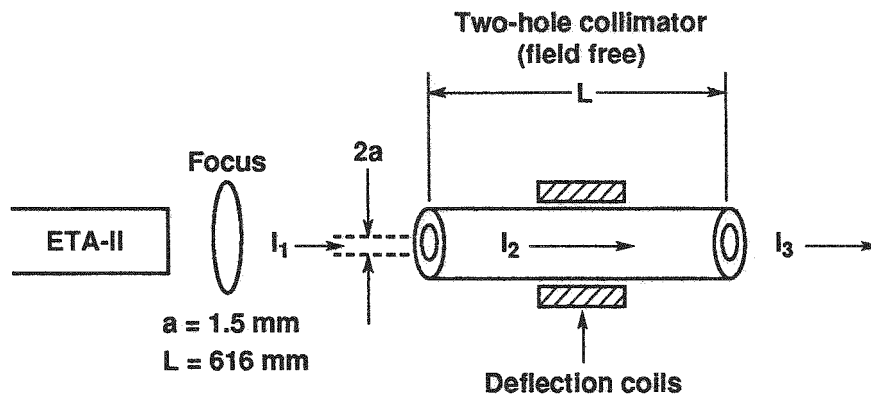

Figure 2. Schematic diagram of the field-free, two-aperture collimator used for electron beam brightness measurements.

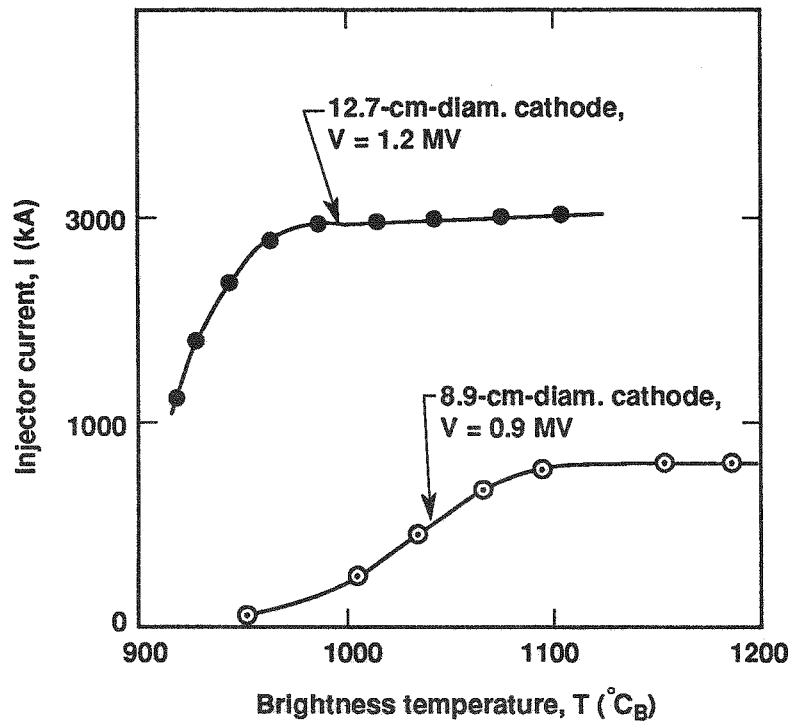

Figure 3. Emission current vs temperature for the (a) 8.9-cm- and (b) 12.7-cm-diam cathodes.

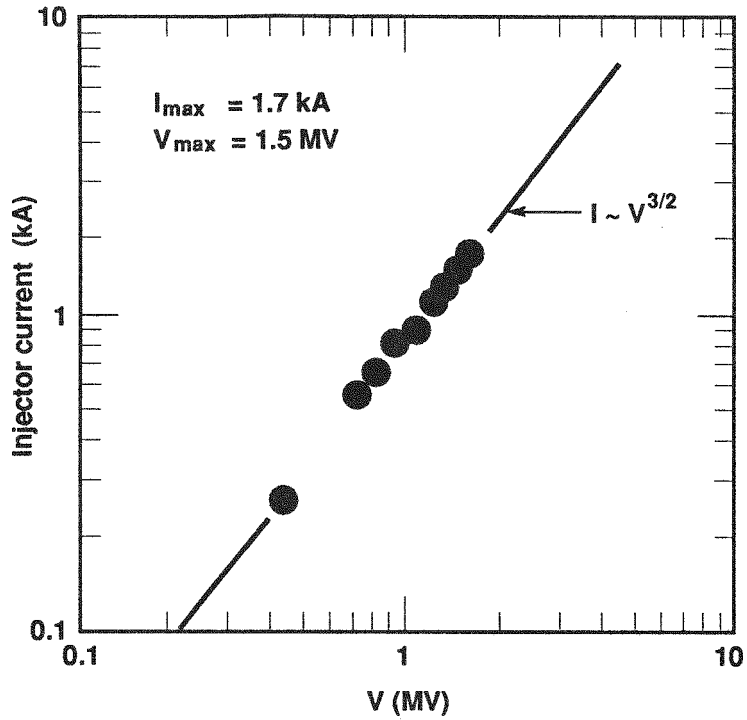

Figure 4. Injector current vs voltage for the 8.9-cm-diam cathode.

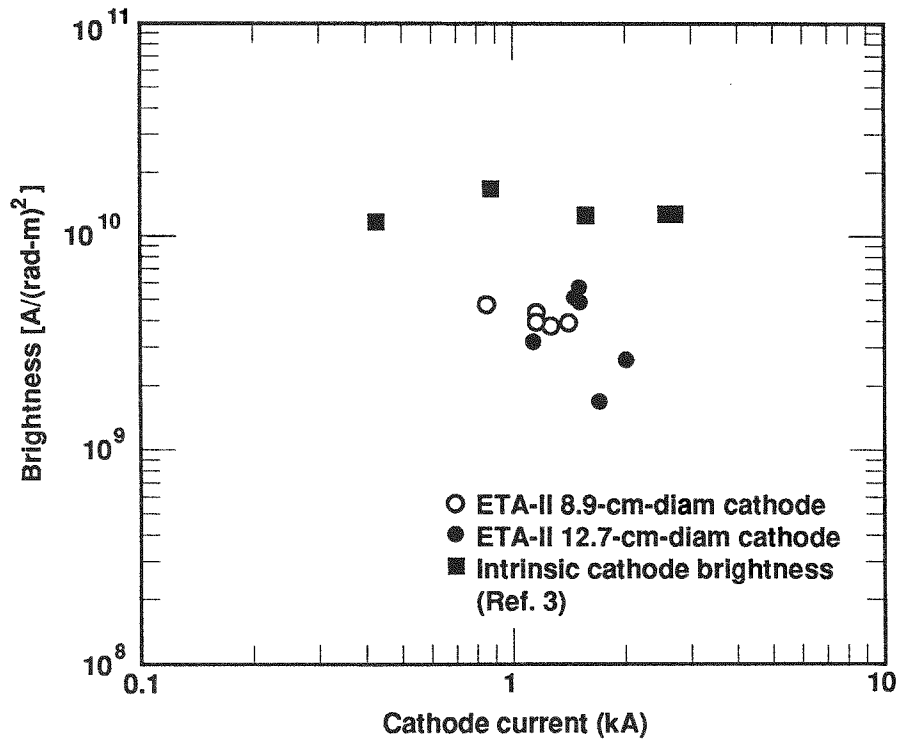

Figure 5. Brightness vs accelerator current.

Table 1. Summary of brightness results obtained with the 8.9-cm diam. cathode.

Date	Beam energy (MeV)	Beam current (kA)	$\beta\gamma$	I_2 (A)	I_3 (A)	δ	J [10^9 A/(rad-m) 2]
11/22/88	2.54	1.15	5.89	24.8	11.8	0.595	4.3
11/29/88	2.54	1.15	5.89	17.0	11.8	0.645	4.0
11/29/88	2.41	0.85	5.63	23 \pm 9	11.3	0.583 \pm 0.058	4.7 \pm 0.5
11/30/88	2.75	1.26	6.31	52.5	11.2	0.565	3.8
12/1/88	2.70	1.40	6.20	62 \pm 22	10.7	0.545 \pm 0.050	3.9 \pm 0.3

Table 2. Summary of brightness results obtained with the 12.7 cm diam. cathode.

Date	Beam energy (MeV)	Beam current (kA)	$\beta\gamma$	I_2 (A)	I_3 (A)	δ	J [10^9 A/(rad-m) 2]
1/17/89	2.74	1.48	6.28	322	9.7	0.366	5.0
1/20/89	2.22	2.0	5.24	33.0	5.6	0.581	2.6
1/27/89	2.14	1.52	5.09	17	10.2	0.540	5.5
1/27/89	2.14	1.52	5.09	17	9.4	0.554	4.9
1/27/89	2.31	1.72	5.43	22	4.5	0.690	1.7
1/31/89	2.05	1.14	5.11	79	4.6	0.446	3.2