

5102-78

DOE/JPL-1060-12
Distribution Category UC-62

MASTER

Thermal Storage Applications Workshop

Held at Golden, Colorado
February 14-15, 1978

Volume II - Contributed Papers

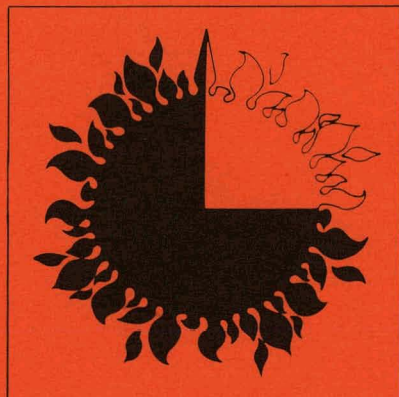

February 15, 1979

Prepared for
U.S. Department of Energy
by
Jet Propulsion Laboratory
California Institute of Technology
Pasadena, California
(JPL PUBLICATION 79-8, VOLUME II)

DISCLAIMER

This report was prepared as an account of work sponsored by an agency of the United States Government. Neither the United States Government nor any agency Thereof, nor any of their employees, makes any warranty, express or implied, or assumes any legal liability or responsibility for the accuracy, completeness, or usefulness of any information, apparatus, product, or process disclosed, or represents that its use would not infringe privately owned rights. Reference herein to any specific commercial product, process, or service by trade name, trademark, manufacturer, or otherwise does not necessarily constitute or imply its endorsement, recommendation, or favoring by the United States Government or any agency thereof. The views and opinions of authors expressed herein do not necessarily state or reflect those of the United States Government or any agency thereof.

DISCLAIMER

Portions of this document may be illegible in electronic image products. Images are produced from the best available original document.

Thermal Storage Applications Workshop

Held at Golden, Colorado
February 14-15, 1978

Volume II - Contributed Papers

February 15, 1979

Prepared for
U.S. Department of Energy
by
Jet Propulsion Laboratory
California Institute of Technology
Pasadena, California
(JPL PUBLICATION 79-8, VOLUME II)

NOTICE

This report was prepared as an account of work sponsored by the United States Government. Neither the United States nor the United States Department of Energy, nor any of their employees, nor any of their contractors, subcontractors, or their employees, makes any warranty, express or implied, or assumes any legal liability or responsibility for the accuracy, completeness or usefulness of any information, apparatus, product or process disclosed, or represents that its use would not infringe privately owned rights.

DISTRIBUTION OF THIS DOCUMENT IS UNLIMITED



Prepared by the Jet Propulsion Laboratory, California Institute of Technology, for the U.S. Department of Energy by agreement with the National Aeronautics and Space Administration.

This report was prepared as an account of work sponsored by the United States Government. Neither the United States nor the United States Department of Energy, nor any of their employees, nor any of their contractors, subcontractors, or their employees, makes any warranty, express or implied, or assumes any legal liability or responsibility for the accuracy, completeness or usefulness of any information, apparatus, product or process disclosed, or represents that its use would not infringe privately owned rights.

ABSTRACT

On February 14 and 15, 1978, a workshop on solar power development and thermal and thermochemical energy storage technology was held at Golden, Colorado. The meeting was sponsored by the United States Department of Energy and organized by the Jet Propulsion Laboratory.

These proceedings contain the record of this workshop. They are divided into two volumes. Volume I presents an analysis and condensation of information discussed in round-table plenary sessions, and also contains the executive summary, workshop agenda, and list of workshop participants. Volume II consists of the papers presented at the workshop, just as they were submitted by the authors.

CONTENTS

SESSION 1	OVERVIEW AND PROGRAMMATIC INFORMATION	
1-1	Storage Applications Workshop...Goals R. Turner, JPL -----	1
1-2	Description of the Solar Thermal Program G. Braun, DOE -----	11
1-3	Description of the Thermal and Thermochemical Energy Storage Program J. Gahimer, DOE -----	29
1-4	Survey of Needs for Energy Storage in a Solar Thermal Electric Power Plant R. Bruce, Aerospace Corp. -----	39
1-5	High Temperature Storage Technologies for Solar Thermal Applications L. Gordon, NASA/LeRC -----	47
1-6	Thermochemical Energy Storage Systems - A Review T. Bramlette, Sandia-L -----	63 <i>deep</i>
SESSION 2	TECHNICAL ISSUES	
2-1	Thermal Storage Requirements Criteria for Solar Power Plants Interfacing with Utility Systems W. Melton, Aerospace Corp. -----	113
2-2	Optimal Dispatch of Storage for Solar Plants in a Conventional Electric Grid J. Woodard, Sandia-L -----	123
2-3	Thermal Storage Cost/Temperature Tradeoffs for Solar Total Energy Systems (STES) M. Donabedian, Aerospace Corp. -----	139
2-4	The Value of Energy Storage for Direct-Replacement Solar Thermal Power Plants T. Anderson, ORNL -----	169
2-5	Systems Analyses of Storage in Specific Solar Thermal Power Applications H. Dodd, Sandia-L -----	199
2-6	The Value of Seasonal Storage of Solar Energy J. Iannucci, Sandia-L -----	213

2-7	Criteria for Selection of the Thermal Storage System for the 10 MW(e) Solar Power Plant to be Built in Barstow, California	
	L. Radosevich, Sandia-L -----	249
2-8	Need for Specific Requirements by Storage System Development Teams	
	J. Calogeras, NASA/LeRC -----	267

Session 1

OVERVIEW AND PROGRAMMATIC INFORMATION

STORAGE APPLICATIONS WORKSHOP...GOALS

BY

R. H. TURNER

JET PROPULSION LABORATORY

- EXCHANGE INFORMATION REGARDING APPLICATIONS OF STORAGE IN POWER APPLICATIONS
 - DETERMINE PRESENT STATE OF STORAGE APPLICATIONS TECHNOLOGY
 - IMPROVE COMMUNICATIONS BETWEEN VARIOUS WORKERS

- PROVIDE A FORUM FOR DISCUSSING AND BRINGING TO LIGHT CERTAIN PERTINENT PROBLEMS

- HELP FORMULATE POLICY REGARDING WHAT RESEARCH NEEDS TO BE PURSUED
 - WHAT SHOULD BE FUTURE PRIORITIES REGARDING STORAGE DEVELOPMENT FROM THE VIEWPOINT OF SOLAR POWER?

ANTICIPATED OUTPUTS FROM THE WORKSHOP

- DEFINITION OF PROBLEMS (AND NON-PROBLEMS) WHICH ARE ASSOCIATED WITH THE FIELD
- GUIDANCE AS TO WHERE EFFORT FOR FURTHER RESEARCH IS NEEDED
- FORMATION OF COMMITTEES OR GROUPS (IF APPROPRIATE) TO RESOLVE CERTAIN POINTS
- INCREASED COOPERATION BETWEEN VARIOUS RESEARCHERS

STORAGE APPLICATIONS WORKSHOP...STRUCTURE

FIRST DAY (TUESDAY, FEBRUARY 14)

- OVERVIEW PAPERS (6 PAPERS)
- PAPERS DISCUSSING SPECIFIC AREAS (9 PAPERS)
- PLENARY SESSION
- CASH BAR (5:30 - 6:30 PM)
- DINNER

SECOND DAY (WEDNESDAY, FEBRUARY 15)

- 3 PLENARY SESSIONS
- CATERED LUNCH (NOON - 1:00 PM)
- STRUCTURED WORKSHOP ENDS AT 2:30 PM

GROUND RULE: ALL PAPERS ARE LIMITED TO 20 MINUTES, INCLUDING QUESTIONS!

STORAGE WORKSHOP...PLENARY SESSIONS

- FOUR PLENARY SESSIONS; EACH 1 1/2 HOURS
- ROUND TABLE DISCUSSIONS: EVERYBODY PARTICIPATES
- EACH SESSION HAS TWO CO-CHAIRMEN
- A COURT REPORTER WILL RECORD EVERYTHING THAT IS SAID AT EACH PLENARY SESSION

STORAGE WORKSHOP PROCEEDINGS

TO BE PUBLISHED BY JPL

COMPOSED OF TWO PARTS

- ANALYSIS OF PLENARY SESSIONS (VOL. I)
- COMPILATION OF SUBMITTED PAPERS (VOL. II)

ENERGY STORAGE MODES

- ELECTRICAL STORAGE (EXTERNAL STORAGE)
 - BATTERIES
 - COMPRESSED GAS
 - HYDRO-PUMPING
 - FLYWHEEL

- THERMAL STORAGE (INTERNAL STORAGE)
 - SENSIBLE HEAT (TEMPERATURE CHANGES WITH HEAT ADDITION)
 - LATENT HEAT (PHASE CHANGES WITH HEAT ADDITION, USUALLY AT CONSTANT TEMPERATURE)

- CHEMICAL STORAGE (INTERNAL STORAGE)
 - ENERGY STORED IN A CHEMICAL REACTION (USUALLY STORED AT AMBIENT TEMPERATURE)

ENERGY STORAGE IN A POWER PLANT

ELECTRICAL STORAGE (EXTERNAL)

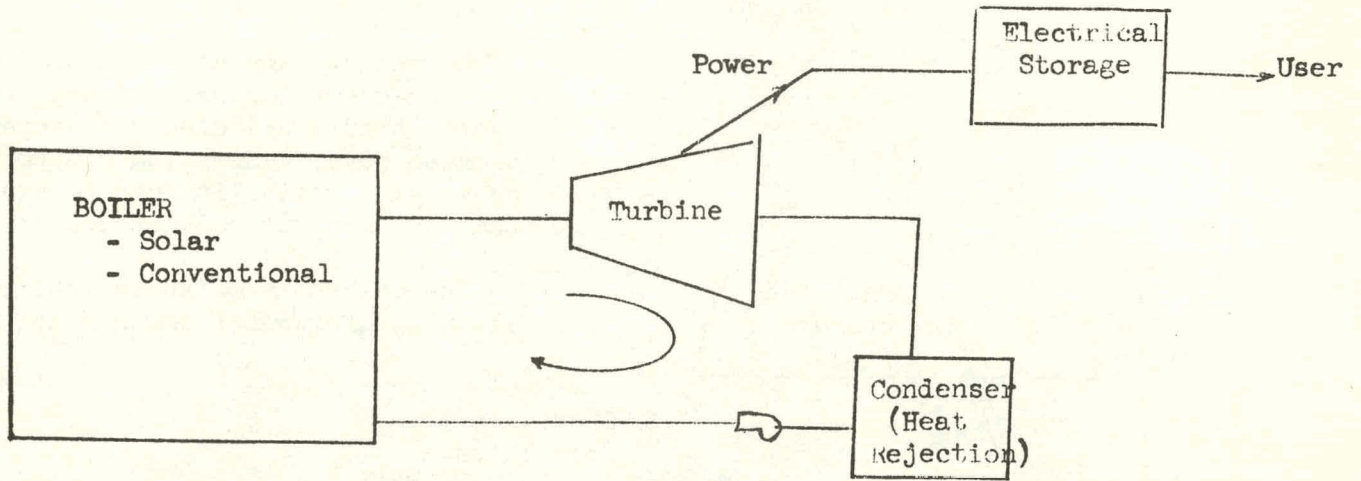

THERMAL STORAGE

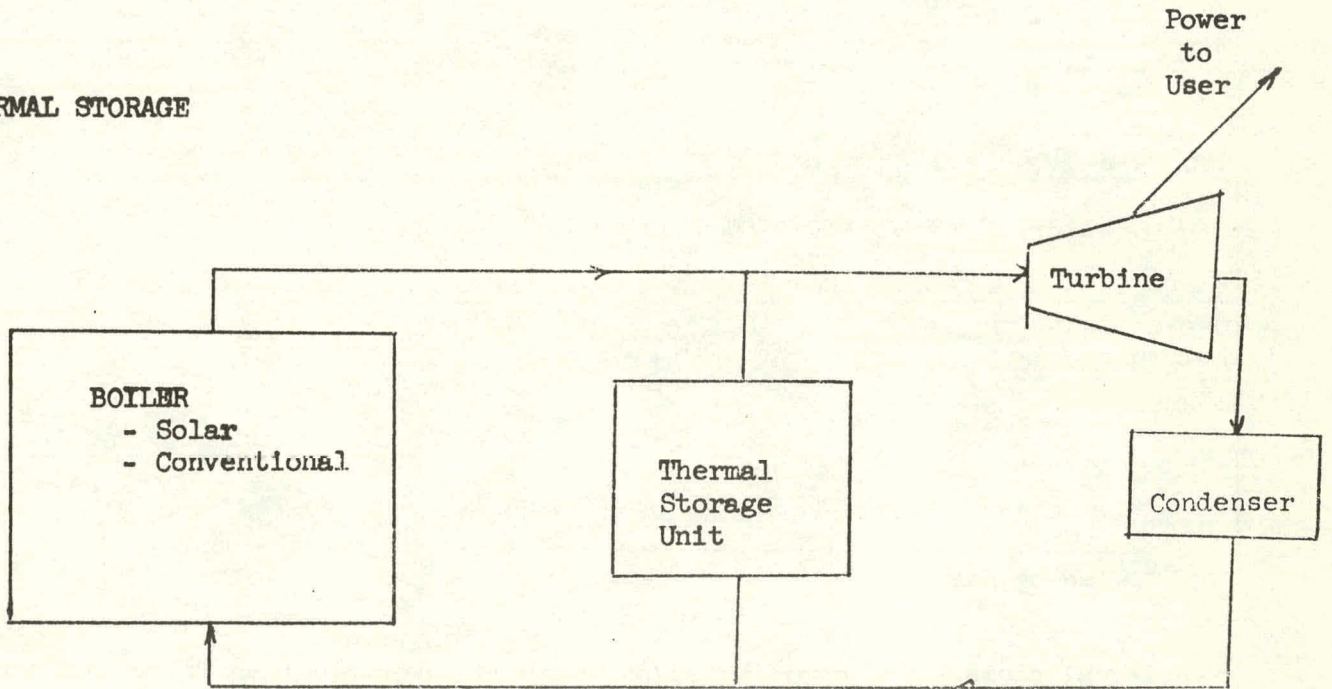

WHAT KIND OF STORAGE SHOULD BE SPECIFIED FOR A POWER PLANT?

SOLAR POWER PLANT

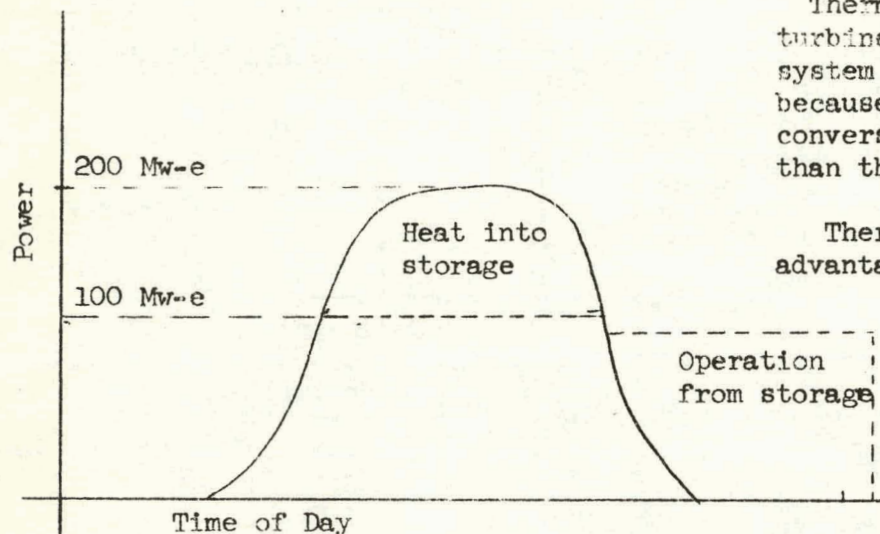

Thermal storage allows a smaller turbine-generator set and heat rejection system than would electric storage because power generating equipment conversion capability can be smaller than the maximum collected heat rate.

Thermal storage has an inherent advantage for solar power plant

BASELOAD POWER PLANT

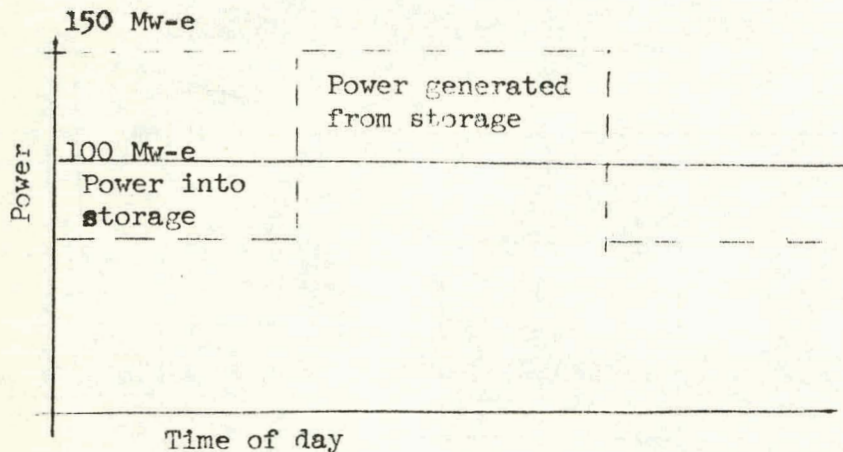

Electrical storage designed to allow baseload power plant to follow a demand load makes possible the minimum size of power generating equipment. If thermal storage is used in this application, then the power generating equipment must not only be sized larger than the baseload average, but also has a lower time utilization factor, which is economically bad.

Electrical storage has an inherent advantage for baseload power plants.

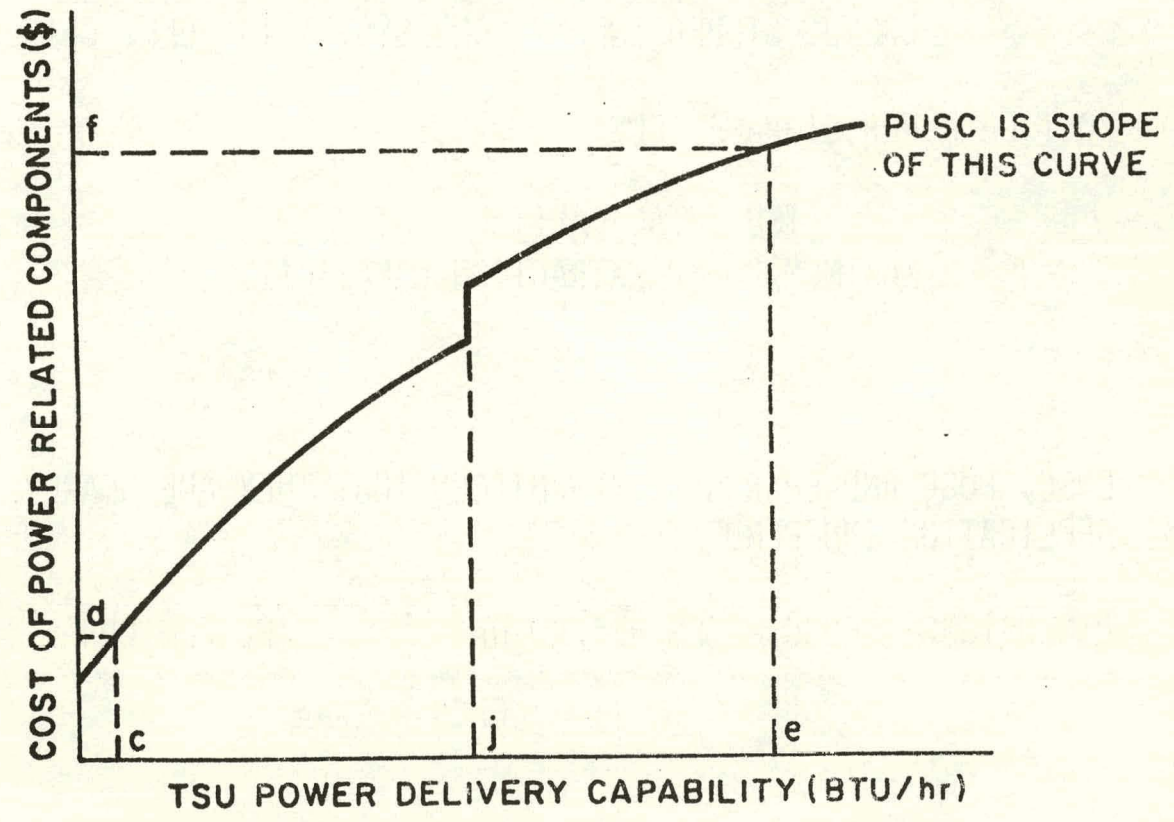
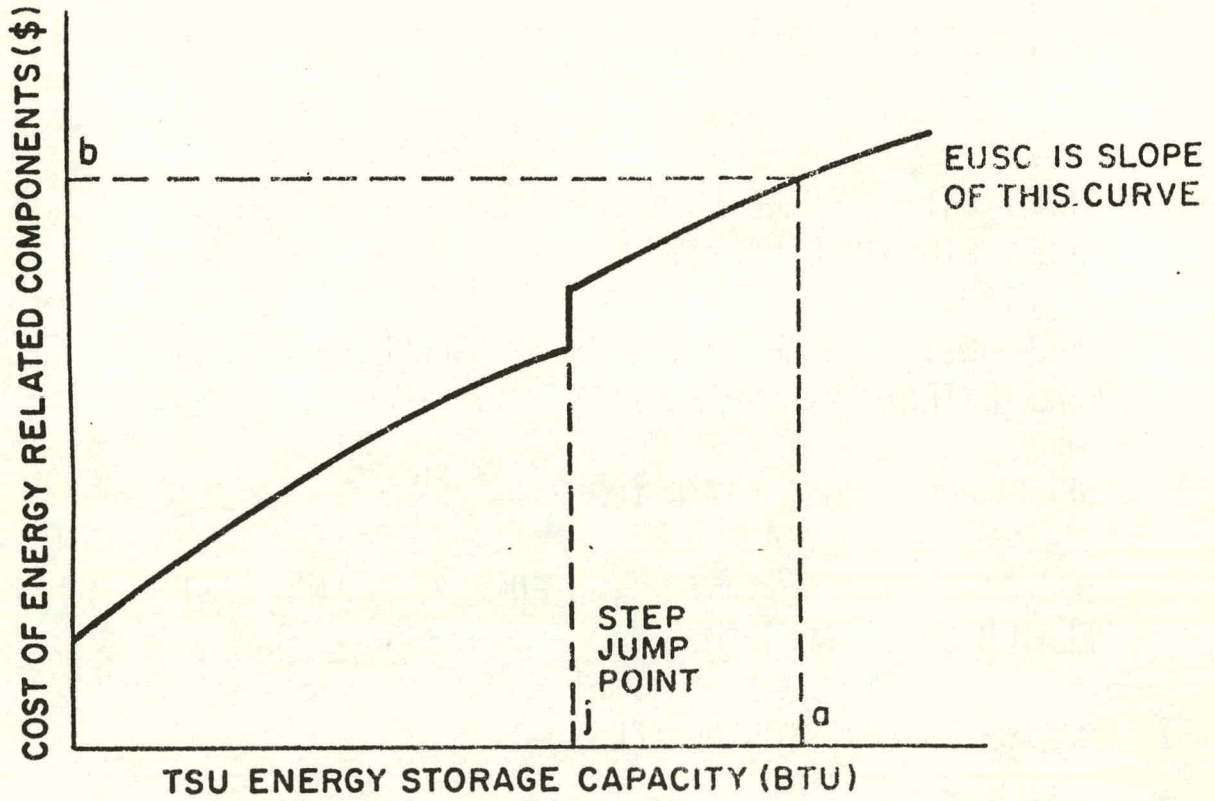

TSU Energy and Power Related Costs Versus System Capabilities

PROPOSED COST PARAMETERS RELATING TO TES SYSTEMS

(1) ENERGY UNIT STORAGE COST (EUSC) = SLOPE OF ENERGY COST VERSUS ENERGY STORAGE CAPACITY

(2) POWER UNIT STORAGE COST (PUSC) = SLOPE OF POWER COST VERSUS POWER EXTRACTION CAPABILITY

(3) ENERGY POWER COST RATIO (EPCR) = $\frac{EUSC}{PUSC}$

(4) TSU TOTAL CAPITAL COST = TSU ENERGY RELATED COST + TSU POWER RELATED COST (\$)

(5) COST OF ENERGY STORAGE (CES) =

$$\frac{\text{TSU TOTAL CAPITAL COST}}{\text{USEFUL STORED ENERGY WHEN SYSTEM IS FULLY CHARGED}}$$

(6) COST OF POWER STORAGE (CPS) =

$$\frac{\text{TSU TOTAL CAPITAL COST}}{\text{MAXIMUM POWER EXTRACTION CAPABILITY}}$$

• EUSC, PUSC AND EPCR HAVE ADVANTAGES THAT THEY ARE NEARLY APPLICATION INDEPENDENT

• DIMENSIONS: EUSC = CES = \$/Kw-HR PUSC = CPS = \$/KW

$$EPCR = 1/HR$$

Department of Energy
Design & Graphics

Vugraph Frame

DESCRIPTION OF THE SOLAR THERMAL PROGRAM

BY G. BRAUN

Department Of Energy
Solar Thermal Power Systems
Program
February 1978

Paper 1-2

Program Scope

Thermal Power Systems

Involve the use of highly concentrating lens or mirror configurations to produce high temperature heat for conversion to electricity and or shaft work.

Alternatives for High Temperature Heat

Oil and Natural Gas

- Clean but Limited
- Import Problem/Balance of Payments

Nuclear

- Nothing More by 1985 Than Now Committed
- Nothing Commercial Above 550°F

Coal

- Constrained
- Logistics
- Siting
- Process Compatibility
- Externalities

Temperature Requirements of National Energy Market

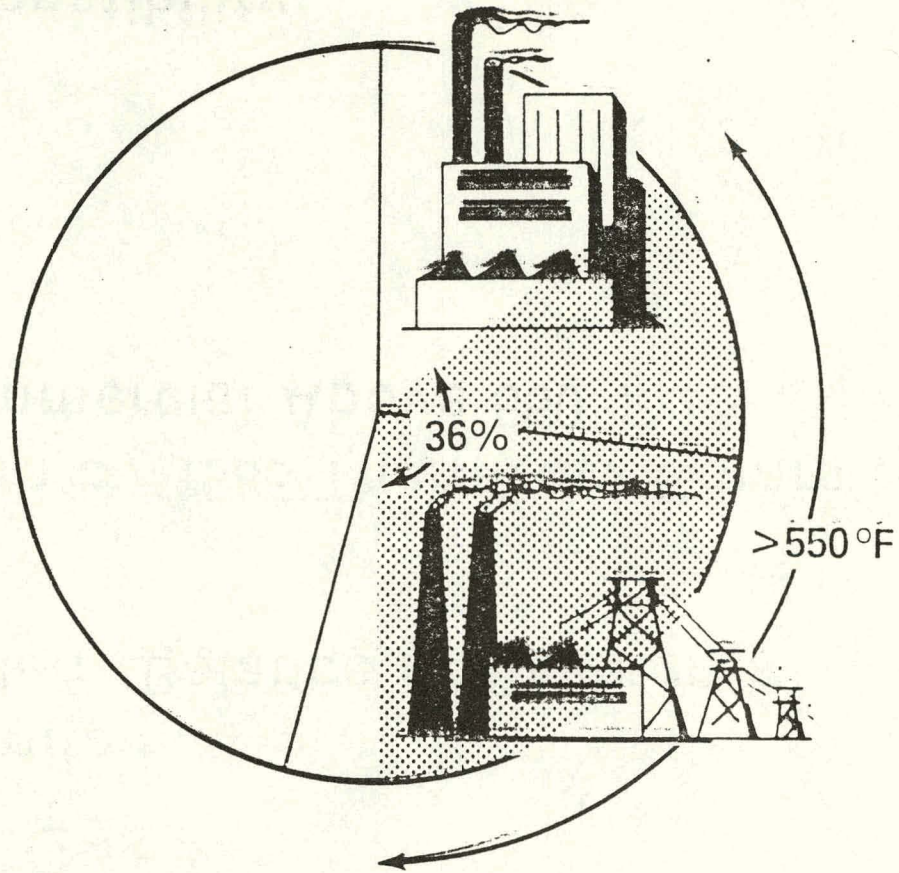

Oil and Gas Use in Electricity Production and Industrial Heat Sectors

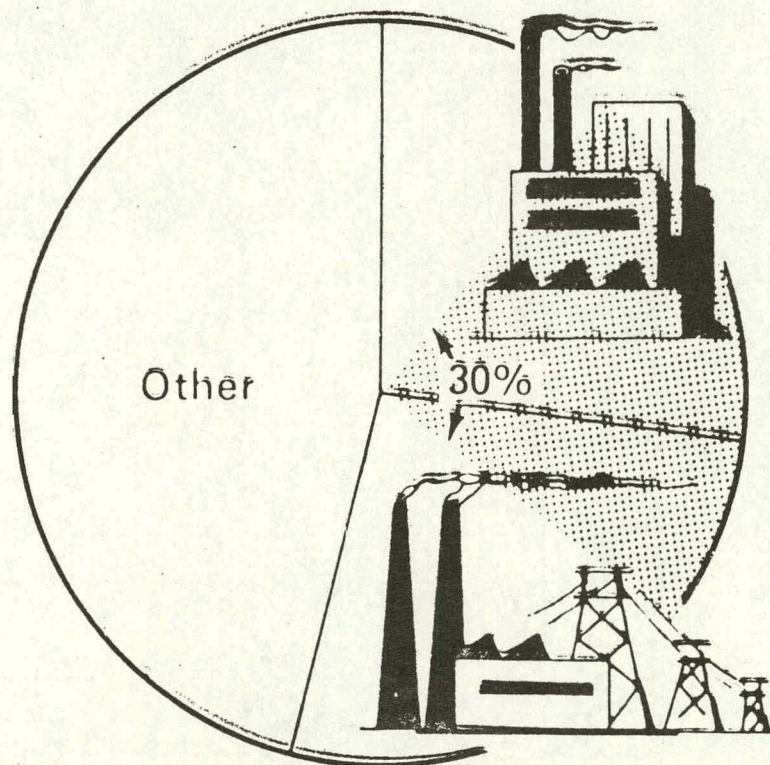

Program Organization

Central Power Applications

- Storage Coupled Systems
- Repowering Of Fossil Fuel Plants
- New Solar Fossil Hybrid Systems
- Central Receiver Subsystems And Components

Advanced Technology

- Supporting Technology
- New Components And Processes
- Advanced System And Subsystem Development
- Far Term Applications
- Facility Usage

Dispersed Power Applications

- Total Energy Solar Systems
- Irrigation Pumping Systems
- Small Power Systems

Program Objectives

- **Initial Commercial Implementation Of Dispersed Solar Thermal Power Systems By Early- 1980's**
- **Establish Central Solar Thermal Power Systems As Economically Viable Generation Resource For Electric Utilities By Mid - 1980's**

Dispersed Power Applications Program

- **Total Energy (Electric & Heat)**
 - Systems/Collector Test Facility in Operation
 - Two Large-Scale (Greater than 100 KW) Thermal Experiments Underway
- **Small Power (Electric and/or Shaft HP)**
 - First of Two Irrigation Experiments in Operation
 - Small Power Systems Program in Place at JPL

Central Power Applications

- **Central Receiver**
 - 10 MWe Pilot Plant
 - Alternative Concepts
 - Hybrid Concepts (Solar/Fossil)
 - Repowering
 - New Plants
- **Linear Receiver**
- **Component Development**
 - Low Cost Heliostats
 - Low Cost Receivers
- **Solar Thermal Test Facility (STTF)**

Advanced Technology Subprogram

- Program Interface with Other Divisions
 - Storage
 - Small Heat Engines
- Emphasis on High Performance Subsystems
- Small Central Receiver Test Facility Now in Operation

FY 78

- **Full Operation of a Test Facility Supporting Each Subprogram**
- **Award Contracts for 10 MWe System Experiment**
- **Site and Contractor Selection for Small Electric Applications Experiment**

1979 Projected Achievements

Dispersed Power Applications

- Complete Design & Initiate Construction Of 3 Large-Scale Total Energy Experiments
 - Fort Hood, Texas
 - Shenandoah, Georgia
 - Mississippi County Community College, Bluffville, Arkansas
- Initial Operation Of Second Solar Thermal Irrigation Pumping Experiment - Willard, New Mexico
- Site Selection For First Small Community Experiment

Central Power Applications

- Repowering Existing Power Plants
 - Complete Market And Concept Definition Studies
 - Establish Program For Feasibility Demonstration Experiments
- Initiate Support Of EPRI Brayton Cycle Central Receiver Experiment
- Complete Concept & Definition Evaluation Of
 - Alternative Central Receiver Concepts
 - Hybrid Systems
 - Low Cost Receiver And Heliostat Designs
- Break Ground For Barstow 10 MWe Central Receiver System Experiment

Solar Thermal Power Systems/Storage

Background

- Fuel as Storage
- Storage "Markets"
 - Electricity
 - Heat

78-2078M/2-5

Solar Thermal Power Systems / Storage

Potential

- Near Term

- Total Energy
- "Peak Shaving" Power Plants

- Far Term

- "Baseload" Power Plants
- "Stand Alone" Dispersed Systems

78-2078M/3-5

Solar Thermal Power Systems/Storage

Issues

How to Look at Solar and Storage

- Solar in Context of Pre-Existing Storage
 - On Site
 - Central
- Storage in Context of New Solar
 - Opens Cost Window
 - Puts Solar on Energy Cost Basis with Other Options

78-2078M/4-5

Integration of Solar Thermal Power Plants into Electric Utility Systems

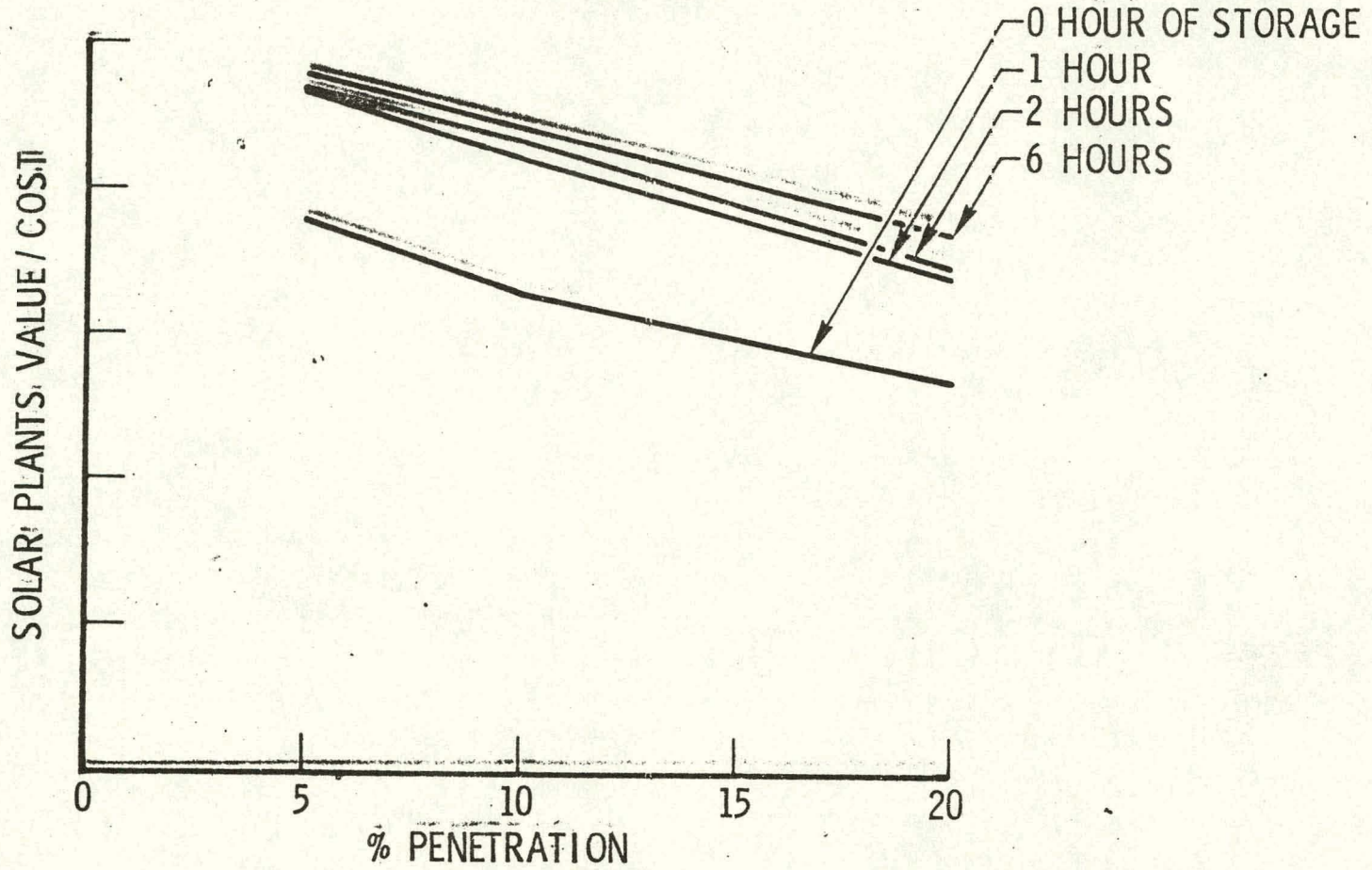

Solar Thermal Power Systems / Storage

Needs

- Clearly Defined Goals
- Match Temperature Capabilities to Near Term Systems
- High Efficiency Concepts for "Baseload" Systems

78-2078M/1-5

**THIS PAGE
WAS INTENTIONALLY
LEFT BLANK**

Paper 1-3

DESCRIPTION OF THE THERMAL AND THERMOCHEMICAL ENERGY STORAGE PROGRAM

BY J. GAHIMER

Energy Storage Systems Division

Thermal Energy Storage and Transport

- **Technologies**
 - **Sensible Heat**
 - **Latent Heat**
 - **Chemical Heat**
- **Field Management**
 - **Low Temperature @ Oak Ridge**
 - **High Temperature @ NASA Lewis**
 - **Thermochemical @ Sandia Livermore**

Thermal Storage and Transport Program

■ Major Thrust Areas

- Seasonal Storage for Heating and Cooling
- Industrial Heat Recovery
- Chemical Heat Pump Storage for Solar Heating and Cooling

■ Key Technology Development Areas

- Residential and Small Commercial Heating and Cooling Storage
- Thermal Storage for Electric Power Generation
- Extended Duration Heat Storage and Transport by Chemical Reactions

■ Concept Development and Supporting R and T

Energy Storage Systems

Summer operation

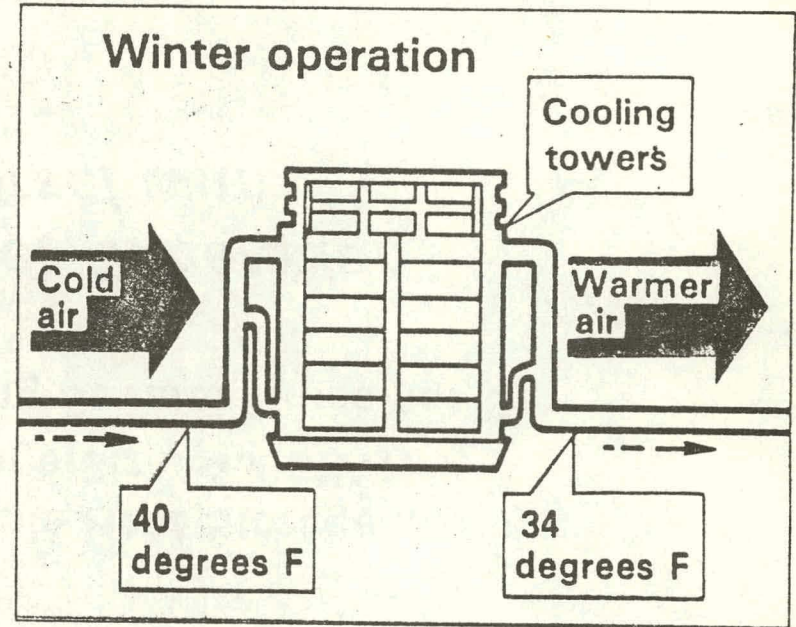
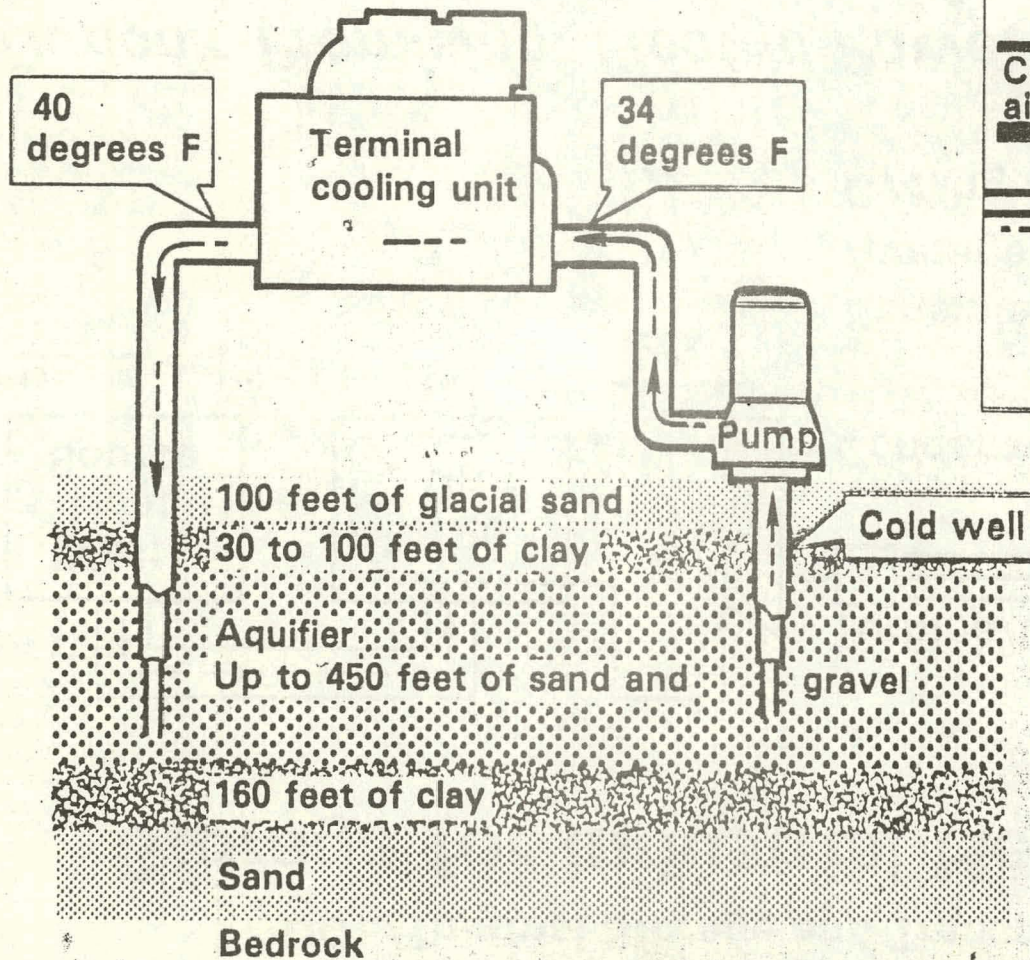

Proposed Kennedy Airport natural cooling system

DOE/Thermal Storage and Transport Program
Storage for Industrial Heat Recovery

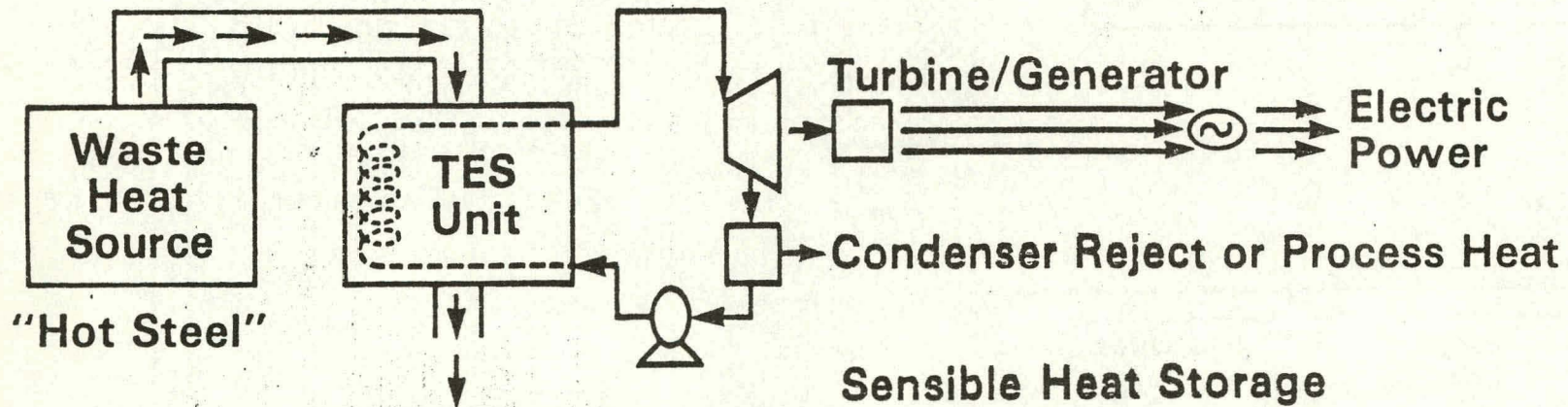

Sensible Heat Storage
Average Size ~30MWH
Cycling Several Times per Day

***Outlook Promising: Electric Power Generation
Bethlehem Steel with
Rocket Res.***

DOE/Thermal Storage and Transport Program
Chemical Heat Pump Storage

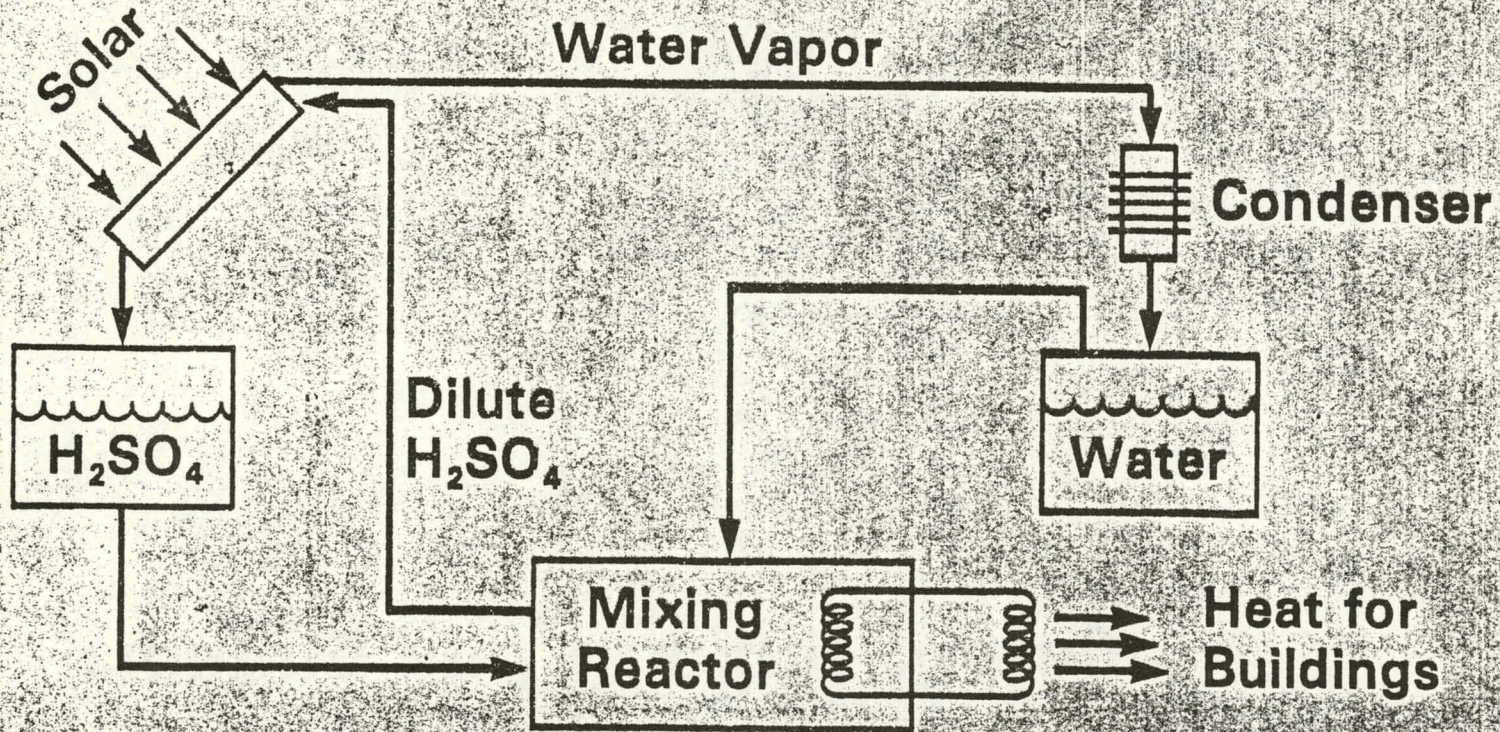

Average size 10MWH.

DOE/Thermal Storage and Transport Program
**Residential and Small Commercial
Heating and Cooling Storage**

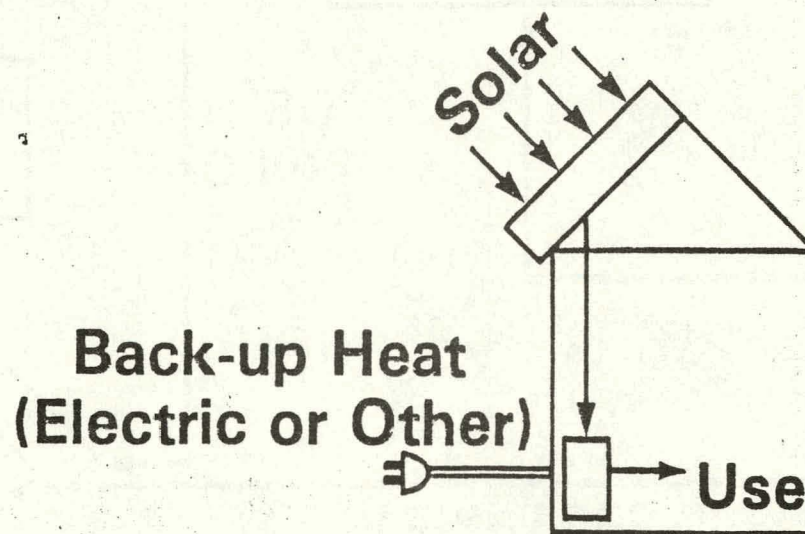

***Average Size 0.1 to 1MWH
Daily Cycling***

DOE/Thermal Storage and Transport Program

Thermal Storage for Electric Power Generator

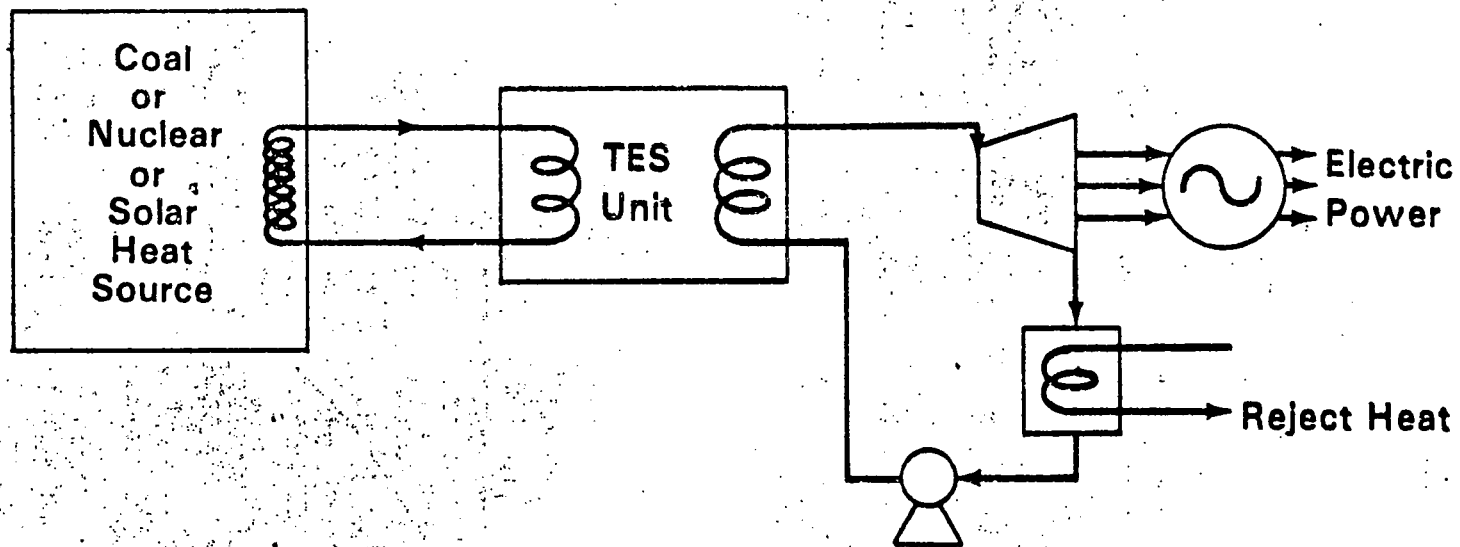

Average Size 300 to 100,000MWH

For Daily Cycling:

Sensible Heat

Phase Change Materials

For Yearly Averaging:

Reversible Chemical Reactions

DOE/Thermal Storage and Transport Program

Heat Storage and Transmission by Reversible Chemical Reactions

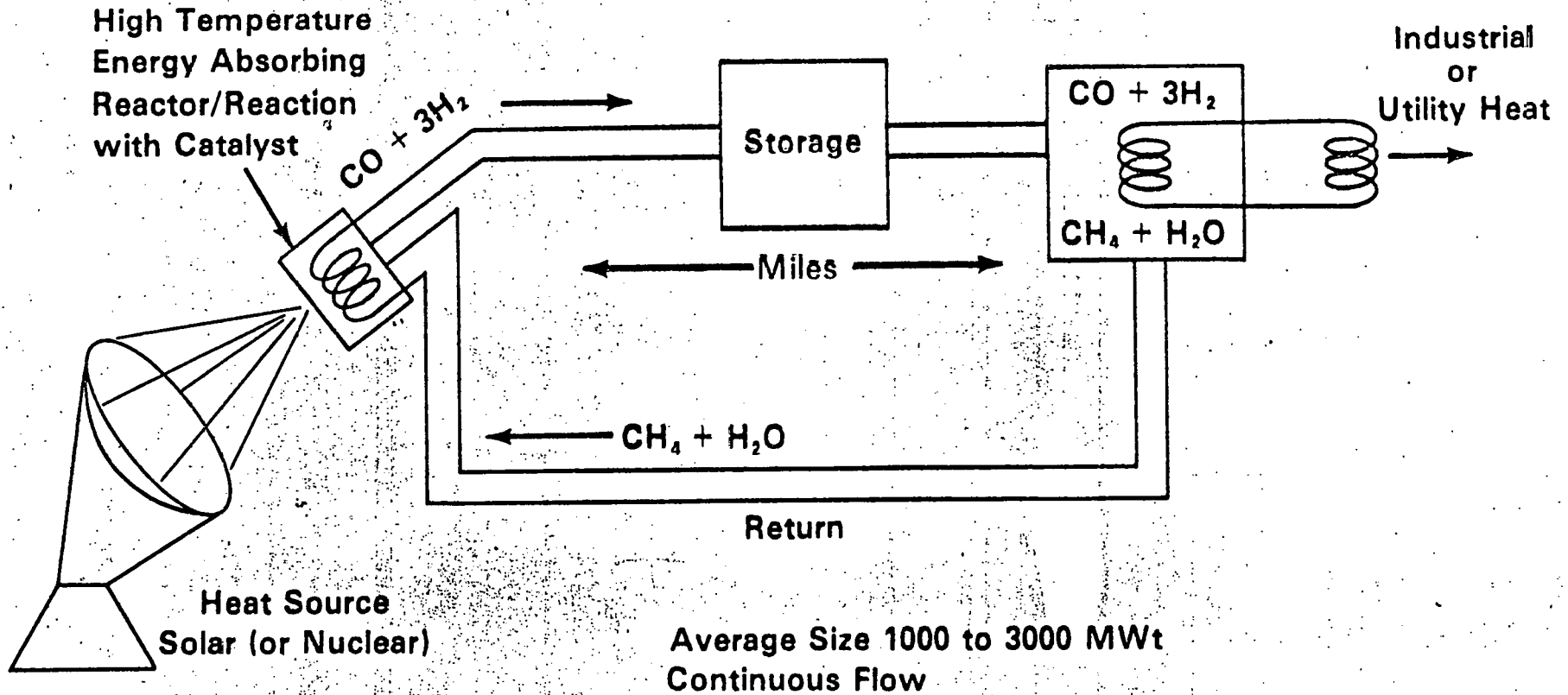

Department of Energy - Division of Energy Storage Systems
Thermal Storage and Transport Program

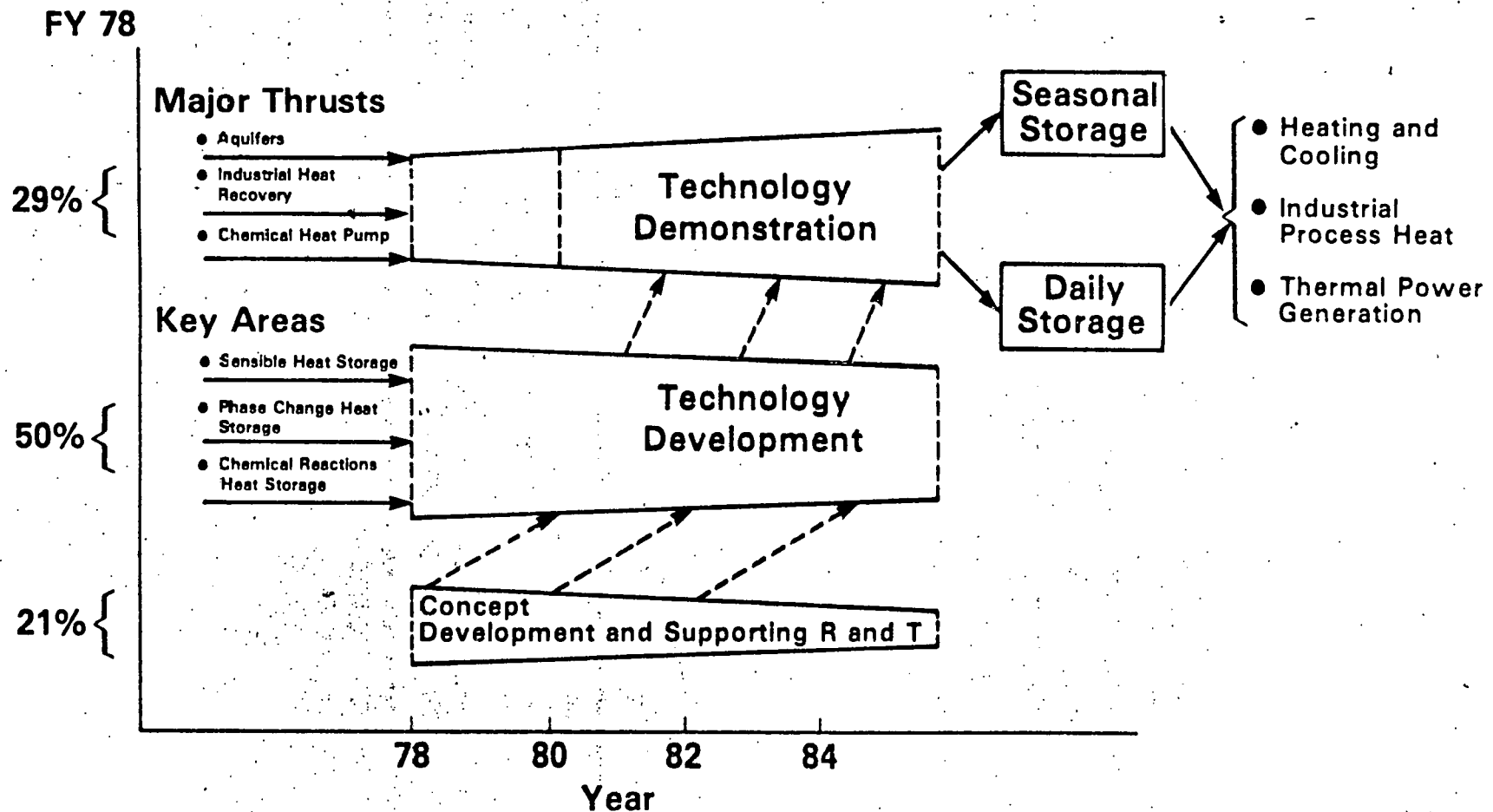

THIS PAGE
WAS INTENTIONALLY
LEFT BLANK

Paper 1-4

**SURVEY OF NEEDS FOR ENERGY STORAGE IN A
SOLAR THERMAL ELECTRIC POWER PLANT**

**R.W. Bruce
The Aerospace Corporation
P.O. Box 92957
Los Angeles, CA 90009**

**14-15 February 1978
Storage Applications Workshop
Solar Energy Research Institute
Golden, CO 80401**

Survey of Needs for Energy Storage in a Solar Thermal Electric Power Plant

- SURVEY OBJECTIVES TO DETERMINE:

Q1 WHAT STORAGE REQUIREMENTS ARE KNOWN - WHAT REQUIREMENTS NEED TO BE DETERMINED?

Q2 WHAT ARE RECOMMENDATIONS FOR FUTURE EFFORTS TO DETERMINE STORAGE REQUIREMENTS AND CHARACTERISTICS?



Survey of Needs for Energy Storage

- SURVEY CONTACTS

- DoE, SOLAR - THERMAL POWER, PHOTOVOLTAIC, WIND
- DoE, STORAGE - THERMAL, THERMOCHEMICAL, ELECTRIC, MECHANICAL
- AEROSPACE CORPORATION
- SANDIA-LIVERMORE
- SANDIA-ALBUQUERQUE
- JET PROPULSION LABORATORY
- OAK RIDGE NATIONAL LABORATORY
- ELECTRIC POWER RESEARCH INSTITUTE
- NASA LEWIS RESEARCH CENTER
- ARGONNE NATIONAL LABORATORY
- OFFICE OF TECHNOLOGY ASSESSMENT



SYSTEM ELEMENTS

CONVENTIONAL

- NUCLEAR
- COAL
- OIL

SOLAR

- SOLAR THERMAL
- PHOTOVOLTAIC
- WIND
- HEATING AND COOLING

STORAGE

- THERMAL
- THERMOCHEMICAL
- ELECTRICAL
- MECHANICAL

STORAGE SYSTEM OPERATING CONCEPTS

SOLAR POWER WITH DEDICATED STORAGE

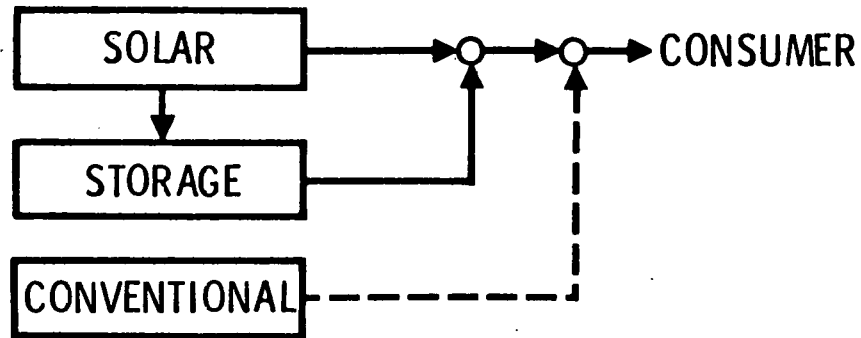

CONVENTIONAL POWER WITH DEDICATED STORAGE

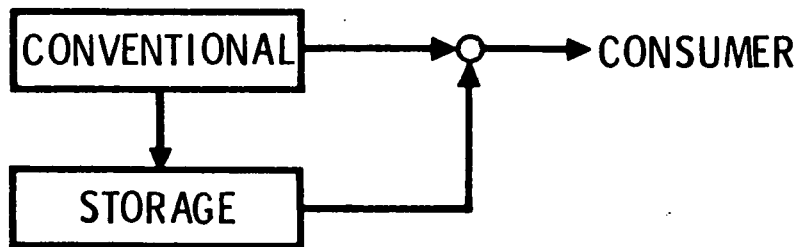

SOLAR AND CONVENTIONAL POWER WITH SHARED STORAGE

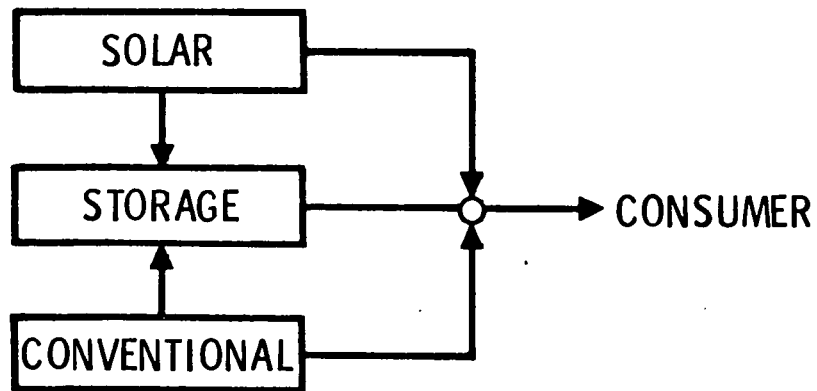

Survey Highlights

Q1 WHAT STORAGE REQUIREMENTS ARE KNOWN - WHAT REQUIREMENTS NEED TO BE DETERMINED?

A1.1 1 TO 2 hr MINIMUM THERMAL STORAGE IS FELT TO BE REQUIRED FOR PLANT PROTECTION AND OPERATIONAL STABILITY IN SOLAR THERMAL POWER APPLICATIONS

A1.2 2 TO 7 hr DEDICATED STORAGE FOR EXTENDED OPERATION OF CENTRAL POWER SYSTEMS ARE COST EFFECTIVE

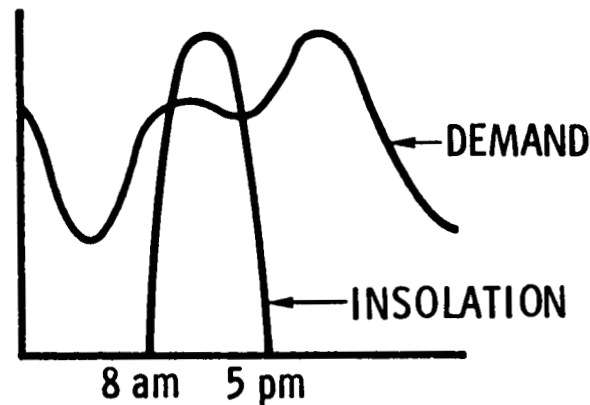

A1.3 STORAGE DISPATCH CRITERIA FOR CENTRAL POWER APPLICATIONS BASED ON ECONOMIC DISPATCH METHODOLOGY ARE YET TO BE FULLY EXPLORED

A1.4 STORAGE REQUIREMENTS FOR CENTRAL POWER APPLICATIONS ARE COMPLICATED BY "SHARED" STORAGE CONSIDERATIONS



Conventional + Storage + Solar

CONDITIONS FOR COST AND FUEL SAVINGS

STORAGE EFFICIENCY, $\eta_s = 0.7$
 STORAGE COST, $C_{I_s} = 60 \text{ \$/kWh}$
 COMB. TURBINE COST, $C_{I_p} = 160 \text{ \$/kW}$
 STORAGE DISCHARGE TIME, $T_d = 10 \text{ hr}$

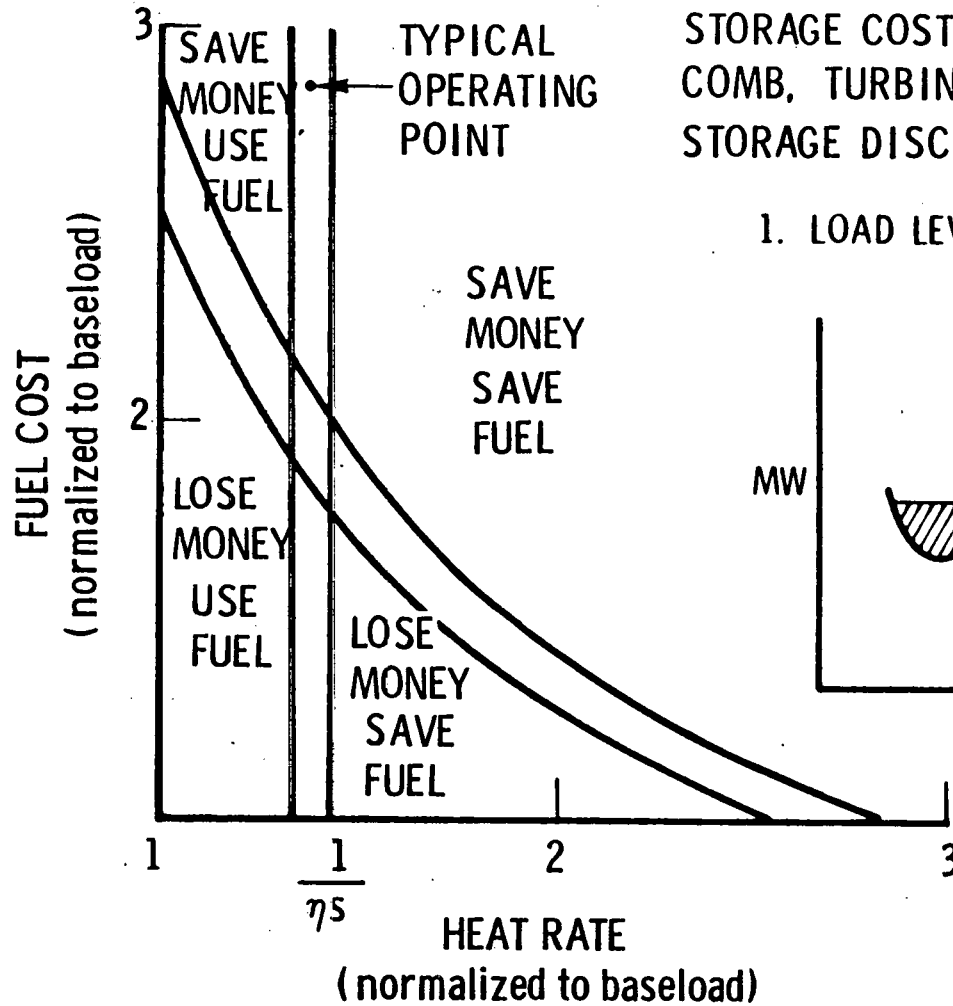

1. LOAD LEVELING ONLY

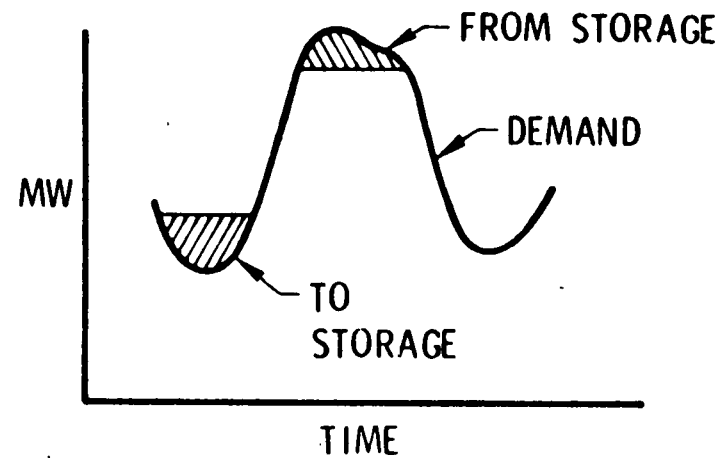

Survey Highlights Cont'd

A1.5 STORAGE REQUIREMENTS FOR DISPERSED APPLICATIONS (up to 23 hr) ARE COMPLICATED BY ARGUMENTS OF "COMPETITION" WITH CENTRAL POWER PLANTS

A1.6 STORAGE REQUIREMENTS ARE COMPLICATED BY EVOLVING SOLAR THERMAL ELECTRIC SYSTEM CONCEPTS

A1.7 THE STATED STORAGE PROGRAM GOALS OF CONSUMER COST SAVINGS AND PREMIUM FUEL SAVINGS CAN BE ACHIEVED

BUT

WAYS TO ACHIEVE STATED GOALS ARE SENSITIVE TO THE CHOSEN APPLICATIONS OF STORAGE

A1.8 ACHIEVEMENT OF GOALS WILL REQUIRE INCREASED CONSIDERATION TO BE GIVEN TO SYSTEM APPLICATIONS ANALYSES

A1.9 COST SAVINGS WILL BE DIFFICULT TO ACHIEVE BEFORE YEAR 2000

A1.10 PREMIUM FUEL SAVINGS CAN BE ACHIEVED NOW, WITH MANY CURRENT SOLAR PLANT CONCEPTS



Survey Highlights

- Q2 WHAT ARE RECOMMENDATIONS FOR FUTURE EFFORTS TO DETERMINE STORAGE REQUIREMENTS AND CHARACTERISTICS?
- A2.1 ASSESSMENT OF POTENTIAL IMPACT OF ENERGY STORAGE NEEDS INCREASED CONSIDERATION-LAST 4 YEARS OF STUDY STILL INCONCLUSIVE
- A2.2 CONTINUOUS ASSESSMENTS OF STORAGE OPTIONS ARE REQUIRED
- A2.3 DIRECTION AND THRUST OF STORAGE TECHNOLOGY EFFORTS CAN BE AIDED BY CLOSER COMMUNICATION TIES WITH SOLAR APPLICATIONS PROGRAMS - AND VICE VERSA
- A2.4 ADDITIONAL STUDY NEEDED IN OPTIMIZATION OF SOLAR UNIT, STORAGE, DISPATCH STRATEGY, AND UTILITY INTEGRATION
- A2.5 ENERGY STORAGE CONCEPTS FOR 1st GENERATION SOLAR THERMAL POWER PLANTS SHOULD BE RE-EXAMINED FOR TYPE (higher °T), AND SIZE
- A2.6 INDEPENDENT APPLICATIONS ANALYSES SHOULD BE CONTINUED, BUT DISSEMINATION OF RESULTS WITHIN THE SOLAR COMMUNITY NEEDS IMPROVEMENT



Paper 1-5

**APPLICATIONS WORKSHOP:
THERMAL STORAGE INTEGRATED INTO SOLAR POWER PLANTS**

**SOLAR ENERGY RESEARCH INSTITUTE
GOLDEN, COLORADO
FEBRUARY 14-15, 1978**

**HIGH TEMPERATURE STORAGE TECHNOLOGIES
FOR
SOLAR THERMAL APPLICATIONS**

PRESENTED BY

**LARRY H. GORDON
NASA-LEWIS RESEARCH CENTER
POWER GENERATION AND STORAGE DIVISION**

HIGH TEMPERATURE STORAGE TECHNOLOGIES
FOR
SOLAR THERMAL APPLICATIONS

Larry H. Gordon
NASA-Lewis Research Center
Power Generation and Storage Division

The general objective in the High Temperature Thermal Energy Storage Project is to develop the technology for cost and performance effective thermal energy storage systems for end-use application sectors. The technologies include all sensible and latent heat storage for temperatures above approximately 250 C. Our primary applications include not only solar energy systems but also conventional electric power generation, industrial processes, transportation, buildings and communities. From this broad matrix, three major development areas and a SR&T base have evolved. As shown in Figure 1, Project Structure, one of these major development areas is "Diurnal Heat Storage for Solar Thermal Power" for both Central and Dispersed Power Systems.

The program logic established to provide promising technologies for these key areas consists of three major elements: System Studies, Concept development, and Technology Validation. The System Studies element is application oriented and includes concept identification, techno-economic feasibility, assessment, and conceptual design studies. The Concept Development element is technology oriented and consists of laboratory scale technology studies, component development, and engineering evaluations of specific candidate storage concepts. The results from these elements will be used to select the more promising concepts and applications for Technology Validation. Within this element, proof-of-concept development and testing will be conducted on a systems scale sufficient to validate the technology and provide reliable projections of costs for the selected systems. Technologies, which successfully complete these elements, can now be transferred to a DOE end-use Division or may be considered developed to the point of acceptance by commercial users.

What technologies are available for high temperature solar thermal applications? What are the current high temperature activities applicable to solar thermal applications? The remaining discussion focuses on answering these questions as well as providing illustrative examples of four technologies which appear attractive as part of the "Diurnal Heat Storage for Solar Thermal Power" key area.

An attempt to classify applicable technologies generated Figure 2, 3. Storage technologies cannot just include sensible and latent media. Instead, the technologies must be "systems" oriented and include containment as well as heat exchange. As is readily apparent, a large, multiple combination matrix can easily result. A similar classification of available energy storage system technologies for our key area "Peak Following Thermal Storage for Steam Electric Power" resulted in 50+ technologies for consideration. Because of system similarities with Central Power and Dispersed Power Applications, one can realistically anticipate a similar number of technologies for consideration.

In the High Temperature Thermal Energy Storage Project, the current programs consider both sensible and latent heat. The sensible heat programs (indicated by title and contractor in figure 4) cover the following technologies:

- o High temperature water (HTW) in iron/steel, heavy walled vessels filled with scrap metal.
- o HTW in pressurized, prestressed cast iron containers.
- o HTW in lined, excavated caverns.
- o Slag, packed bed at 1100 F.
- o Oil/rock, gas/refractory brick
- o Variable pressure, steam accumulator
- o Rock bed, hot air 1000 - 1500 F
- o Pebble filled trenches (underground) hot air.
- o Hot oil filled, leached salt

This latter sensible heat program is aligned to Solar Central Power and is currently being funded by DOE-Solar. Figure 5 illustrates this technology. Another potentially attractive technology for Solar Central Power is illustrated in figures (6) and (7). This prestressed, cast iron, high pressure vessel is presently identified as a leading storage concept for "Peak Following Thermal Storage for Steam Electric Power".

Current latent heat programs are likewise identified in figure (8). In addition to the hydroxide and chloride media technologies, active heat exchange technology can be associated with the Solar Thermal Power key area. Other technologies include:

- o solid/solid phase change, sodium sulfate, packed bed
- o carbonates
- o metal alloy (eutectics)
- o passive heat exchange (tube and shell)
- o phase change modeling

In this latent heat area, engineering evaluation testing has been recently completed on a sodium hydroxide water heater as shown in figure (9). Successful testing of this module (performance, compatibility, etc.) stimulated consideration of a similar NaOH/Thermal-66 concept as a system technology applicable to Dispersed Power Systems. This concept, as well as other potential technologies, is currently being examined by Sandia Albuquerque for possible engineering evaluation testing in their Solar Total Energy Test Facility, figures 10 and 11.

The last example, figure (12), shows our current storage effort for chloride technology. This energy storage-boiler tank stores energy in a molten chloride eutectic and uses evaporation/condensation of a heat transfer fluid for energy transport within the tank.

In summary, numerous, promising technologies from High Temperature Thermal Energy Storage have been presented. Some of these concepts relate directly to Solar Thermal Power applications. Other concepts, although closely aligned to other key application sectors, have potential for Solar Thermal Power. As all of the key areas are developed and with the possible addition of new thrusts in transportation, energy transport, and building/communities, the technology base will increase accordingly. Consequently, more technologies will be available for solar thermal power consideration.

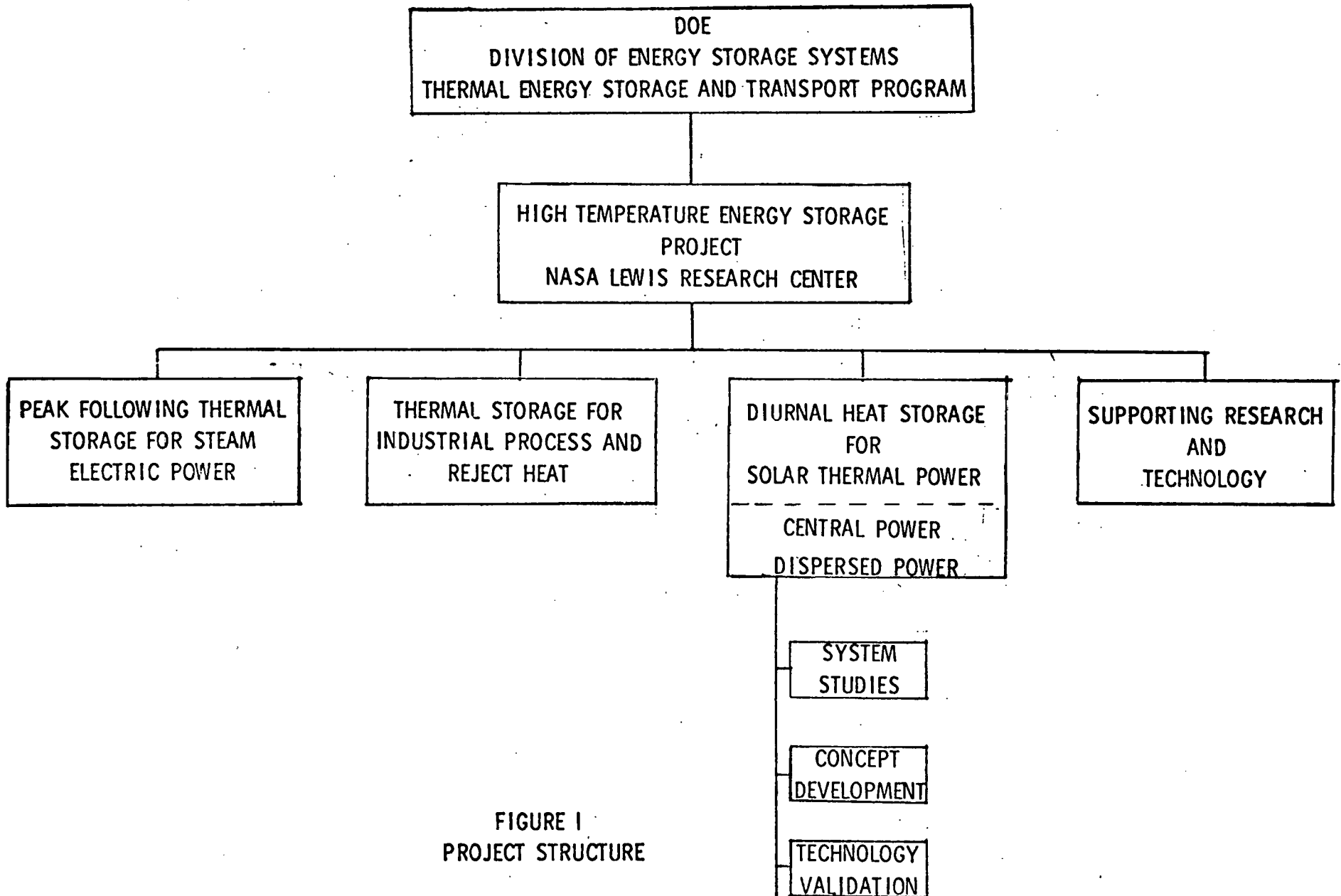

FIGURE I
PROJECT STRUCTURE

MEDIA

SENSIBLE HEAT

LIQUIDS

- o HIGH TEMPERATURE WATER
- o ORGANIC COMPOUNDS
(OILS, SILICONES)
- o INORGANIC COMPOUNDS
(SALTS, SULFUR, METALS)

SOLIDS

- o METALS
(IRON / STEEL)
- o MINERALS
(SILICONE, GRANITE)
- o CERAMICS
(ALUMINA, MAGNESIA)

LATENT HEAT

SOLID / LIQUID

- o NITRATES
- o HYDROXIDES
- o CHLORIDES
- o CARBONATES
- o FLUORIDES

SOLID / SOLID

- o SULPHATES

FIGURE 2

CONTAINMENT

ABOVE GROUND

- o HIGH PRESSURE TANKS (WELDED STEEL, PCIV, PCRIV)
- o LOW PRESSURE TANKS - SENSIBLE (THERMOCLINE, PACKED BEDS)
- o LOW PRESSURE TANKS - LATENT (PCM)

UNDERGROUND

- o STEEL LINED (AIR / CONCRETE SUPPORT)
- o UNLINED NATURAL (AQUIFERS, SALT DOMES EXCAVATED)

HEAT EXCHANGE

ACTIVE

- o SALT REMOVAL FROM SURFACE

PASSIVE

- o CONVENTIONAL TUBE / SHELL

FIGURE 3

HIGH TEMPERATURE THERMAL ENERGY STORAGE PROJECT

CURRENT SENSIBLE HEAT PROGRAMS

- | | |
|--|------------|
| o EVALUATION AND CONCEPTUAL DESIGN OF SYSTEMS FOR NEAR-TERM UTILITY APPLICATIONS | GE |
| o ASSESSMENT OF SOLID SENSIBLE HEAT STORAGE CONCEPTS | JPL |
| o ASSESSMENT OF STORAGE IN PRESTRESSED CAST IRON VESSELS | GILLI |
| o FEASIBILITY STUDY OF HOT WATER STORAGE IN UNDERGROUND EXCAVATED CAVITIES | R&DA |
| o APPLICATION STUDIES OF STORAGE IN INDUSTRIAL PROCESS AND WASTE HEAT RECOVERY | |
| - STEEL AND IRON INDUSTRY | RRC |
| - PAPER AND PULP INDUSTRY | BE&C |
| - CEMENT INDUSTRY | MM |
| o FEASIBILITY STUDY OF ROCK BED HEAT ACCUMULATORS | U. MINN. |
| o FEASIBILITY STUDY OF UNDERGROUND THERMAL STORAGE | U. HOUSTON |

FIGURE 4

SCHEMATIC OF A SALT CAVERN LEACHING OPERATION

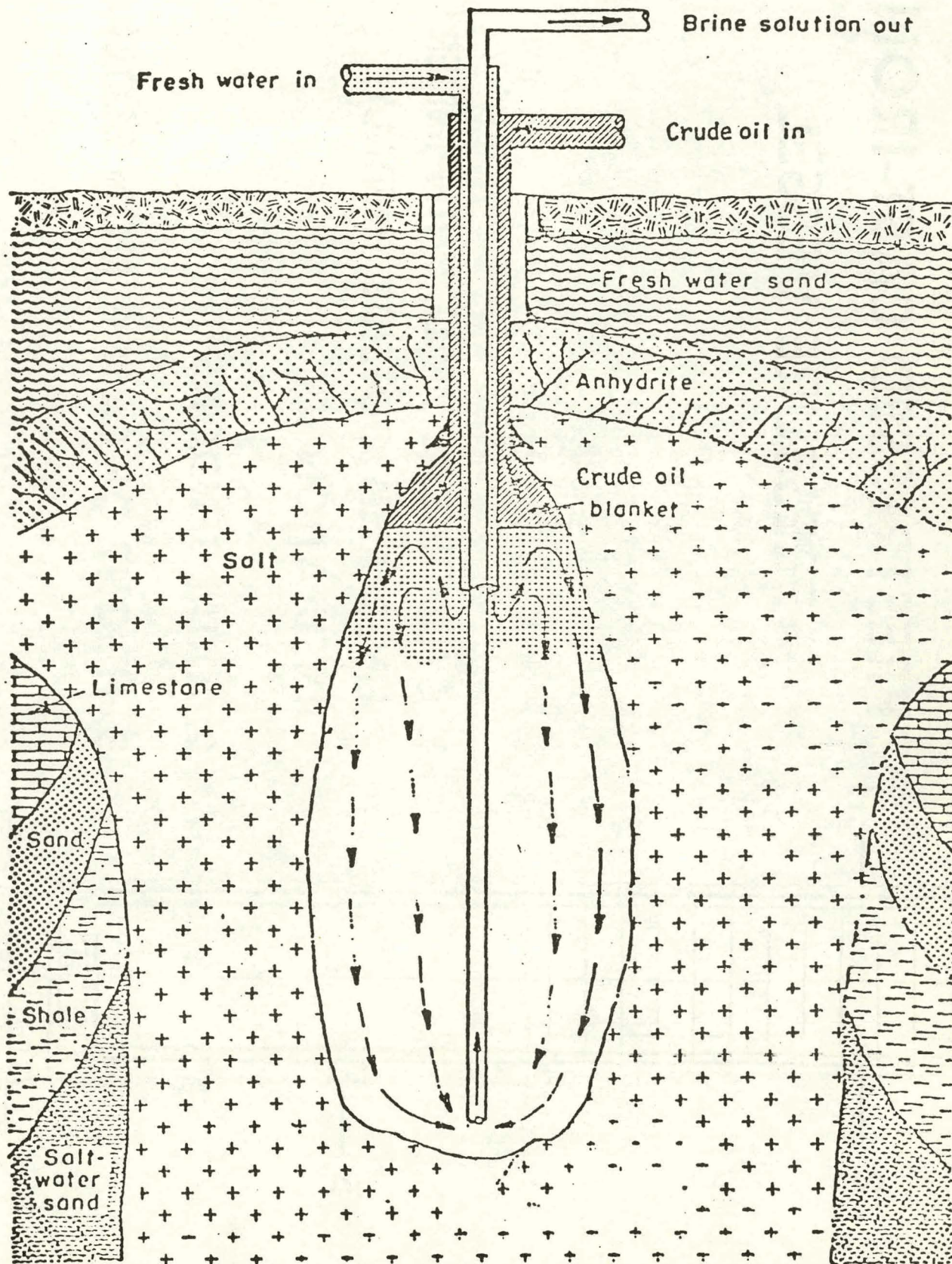
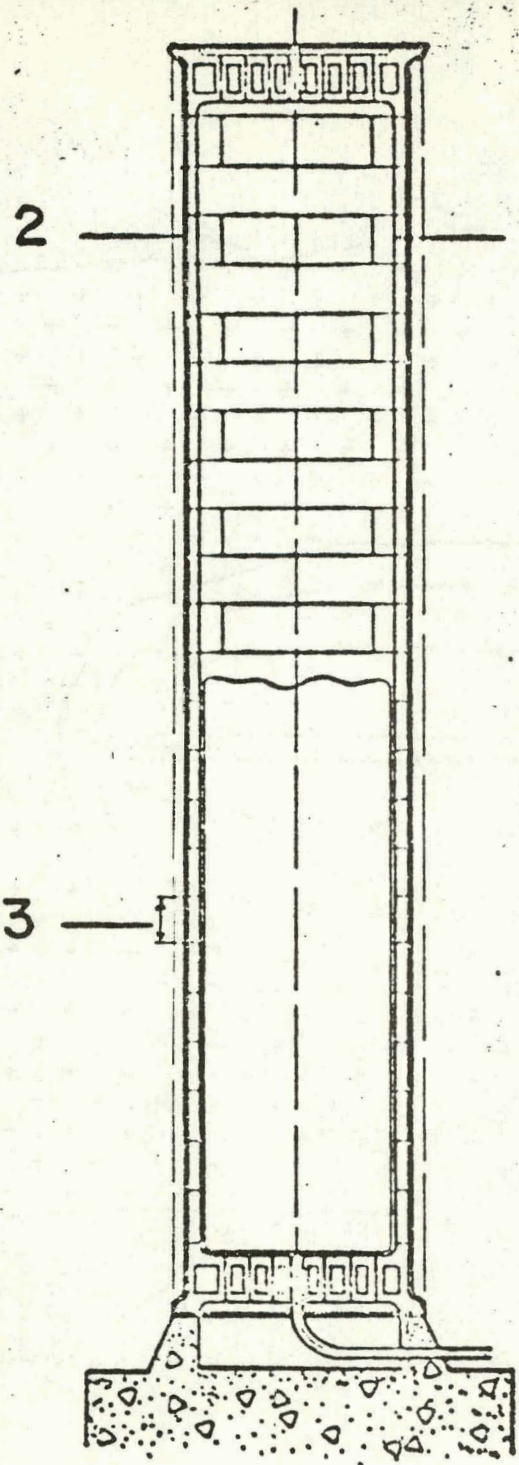

FIGURE 5



PRESTRESSED CAST-IRON PRESSURE VESSEL

1. CYLINDRICAL WALL WITH INNER LINER AND OUTSIDE THERMAL INSULATION
2. AXIAL TENDONS
3. HEIGHT OF CAST — IRON BLOCKS

FIGURE 6

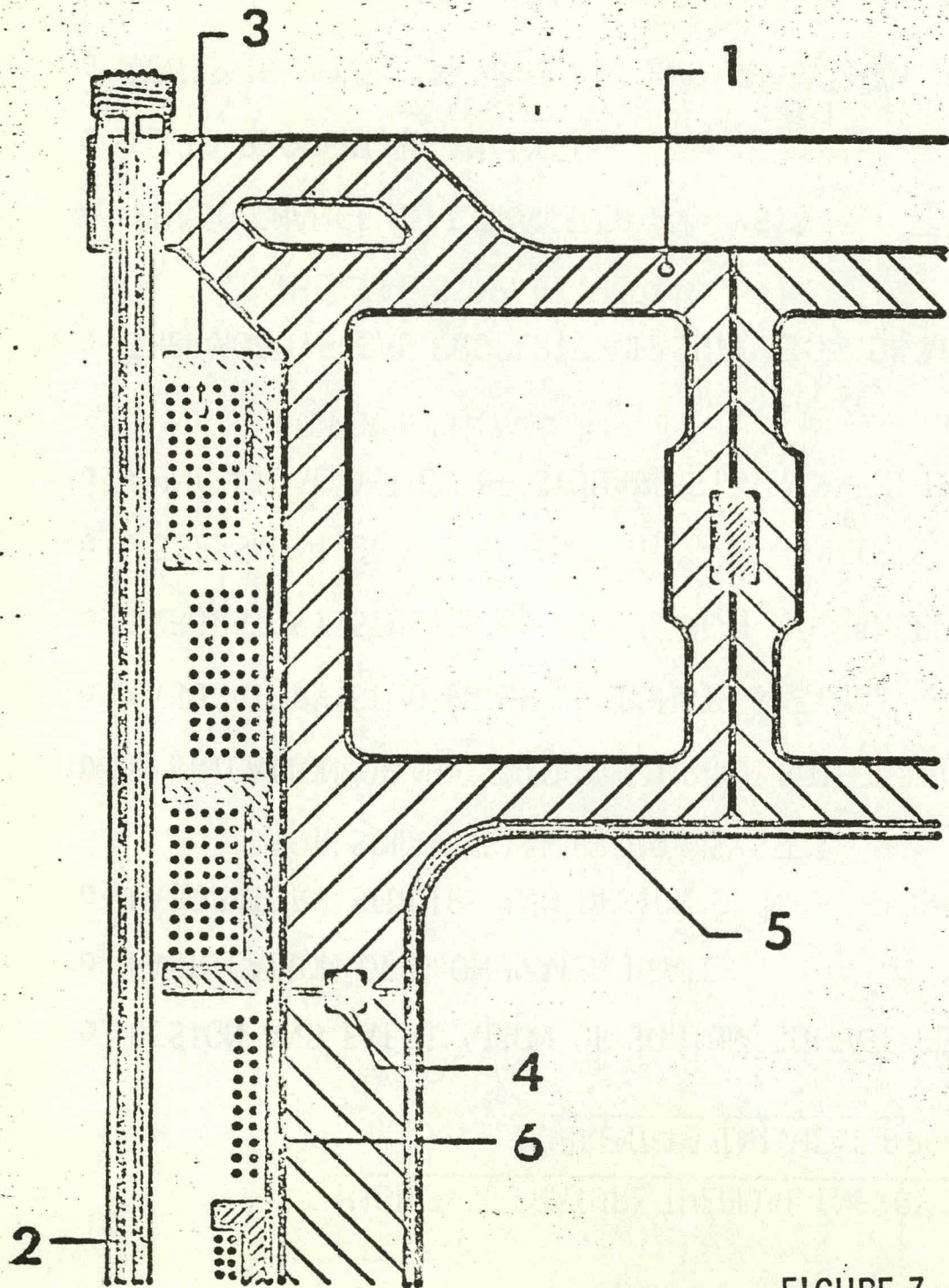

**DETAIL OF
PRESTRESSED
CAST-IRON
PRESSURE VESSEL**

- 1. UPPER COVER
- 2. AXIAL TENDONS
- 3. TANGENTIAL TENDONS
- 4. WEDGE
- 5. LINER
- 6. THERMAL INSULATION

FIGURE 7

HIGH TEMPERATURE THERMAL ENERGY STORAGE PROJECT

CURRENT LATENT HEAT PROGRAMS

- o DESIGN AND FABRICATION OF SODIUM SULFATE PEBBLE BED UNIT CALMAC
- o FABRICATION OF NaOH WATER HEATER C&W
- o LABORATORY STUDIES AND DESIGN OF NaOH STORAGE SYSTEM
FOR SOLAR TOTAL ENERGY SYSTEM C&W
- o FABRICATION OF NRL ENERGY STORAGE BOILER TANK NRL
- o LABORATORY STUDIES OF CARBONATE SYSTEMS IGT
- o LABORATORY STUDIES OF ACTIVE HEAT EXCHANGERS TBD
- o ASSESSMENT OF LATENT HEAT STORAGE CONCEPTS GRUMMAN
- o CONCEPTUAL DESIGN OF STORAGE SYSTEMS FOR THERMAL ELECTRIC
POWER SYSTEMS XEROX
- o THERMOPHYSICAL PROPERTY MEASUREMENTS OF METAL ALLOY
THERMAL STORAGE MEDIA U. DELAWARE
- o PHASE CHANGE HEAT TRANSFER ANALYSIS U. HOUSTON
- o FLUID PROPERTIES ANALYSIS NBS
- o LEWIS IN-HOUSE EXPERIMENTS AND ANALYTICAL SUPPORT LeRC

FIGURE 8

ERDA HIGH TEMPERATURE THERMAL ENERGY STORAGE PROJECT

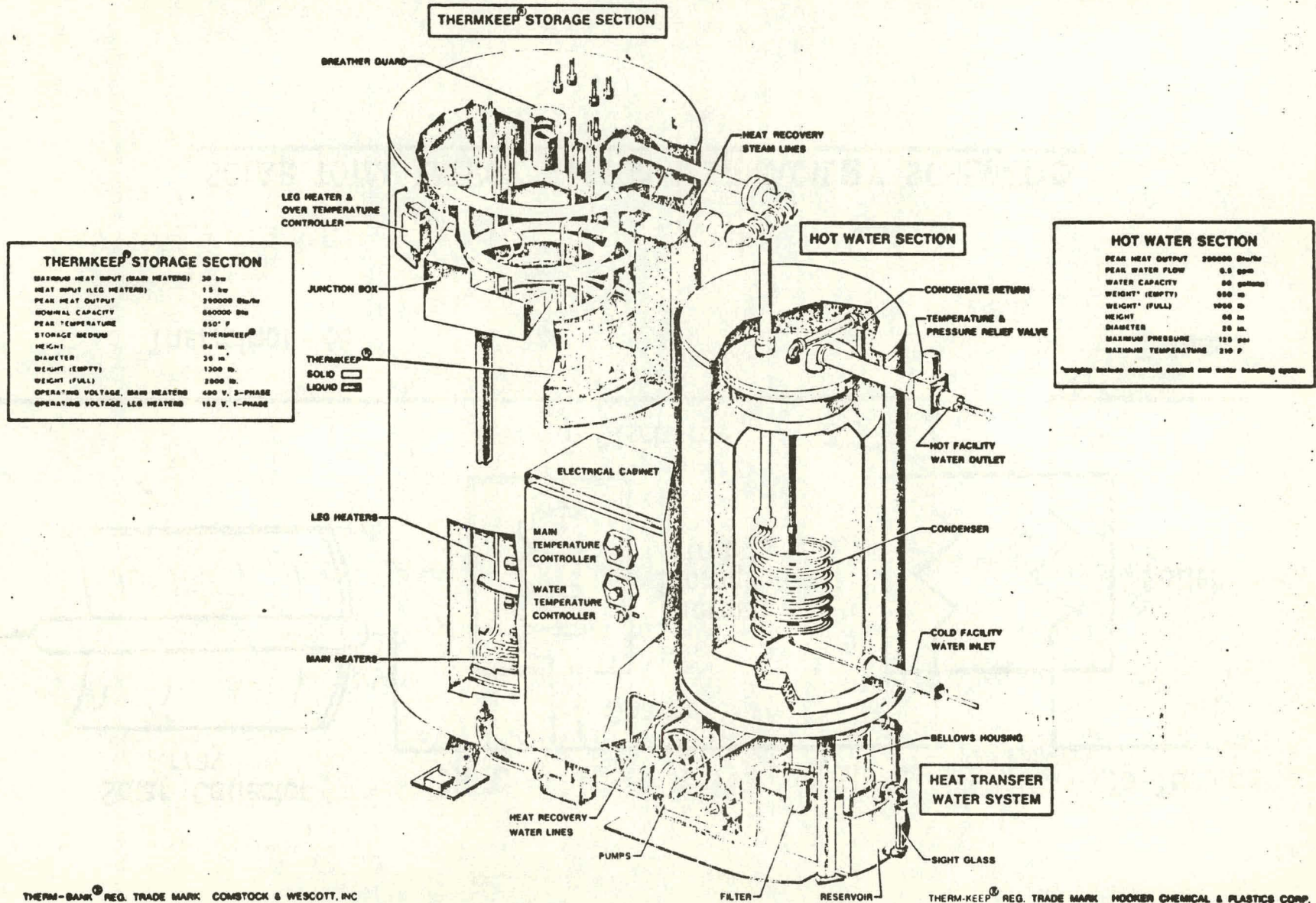

THERM-BANK[®] REG. TRADE MARK CONSTOCK & WESCOTT, INC.

THERM-KEEP[®] REG. TRADE MARK HOOKER CHEMICAL & PLASTICS CORP.

THERM-BANK[®] ELECTRIC WATER HEATER

CD-12142-34

FIGURE 9

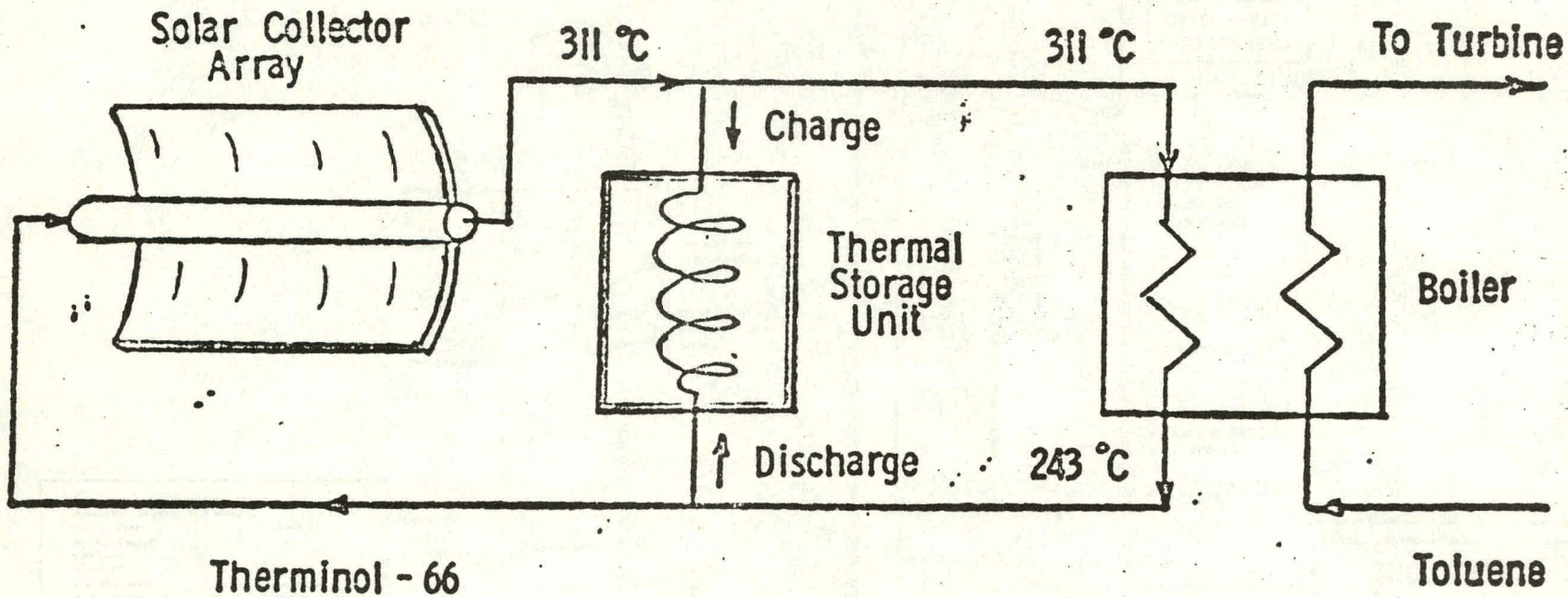

SOLAR TOTAL ENERGY SYSTEM TEST FACILITY SCHEMATIC

FIGURE 10

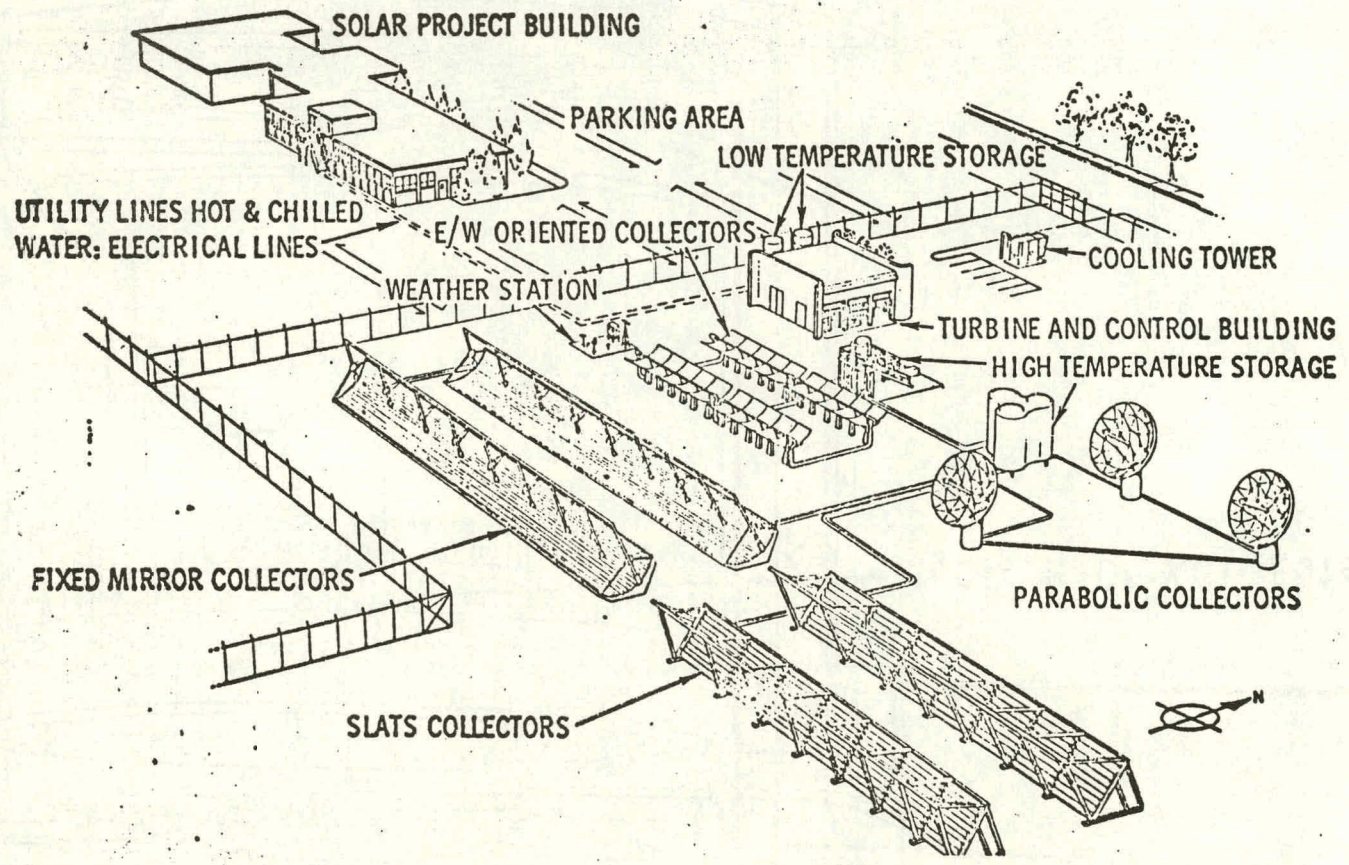

SOLAR TOTAL ENERGY SYSTEM TEST FACILITY
SANDIA ALBUQUERQUE

FIGURE II

19

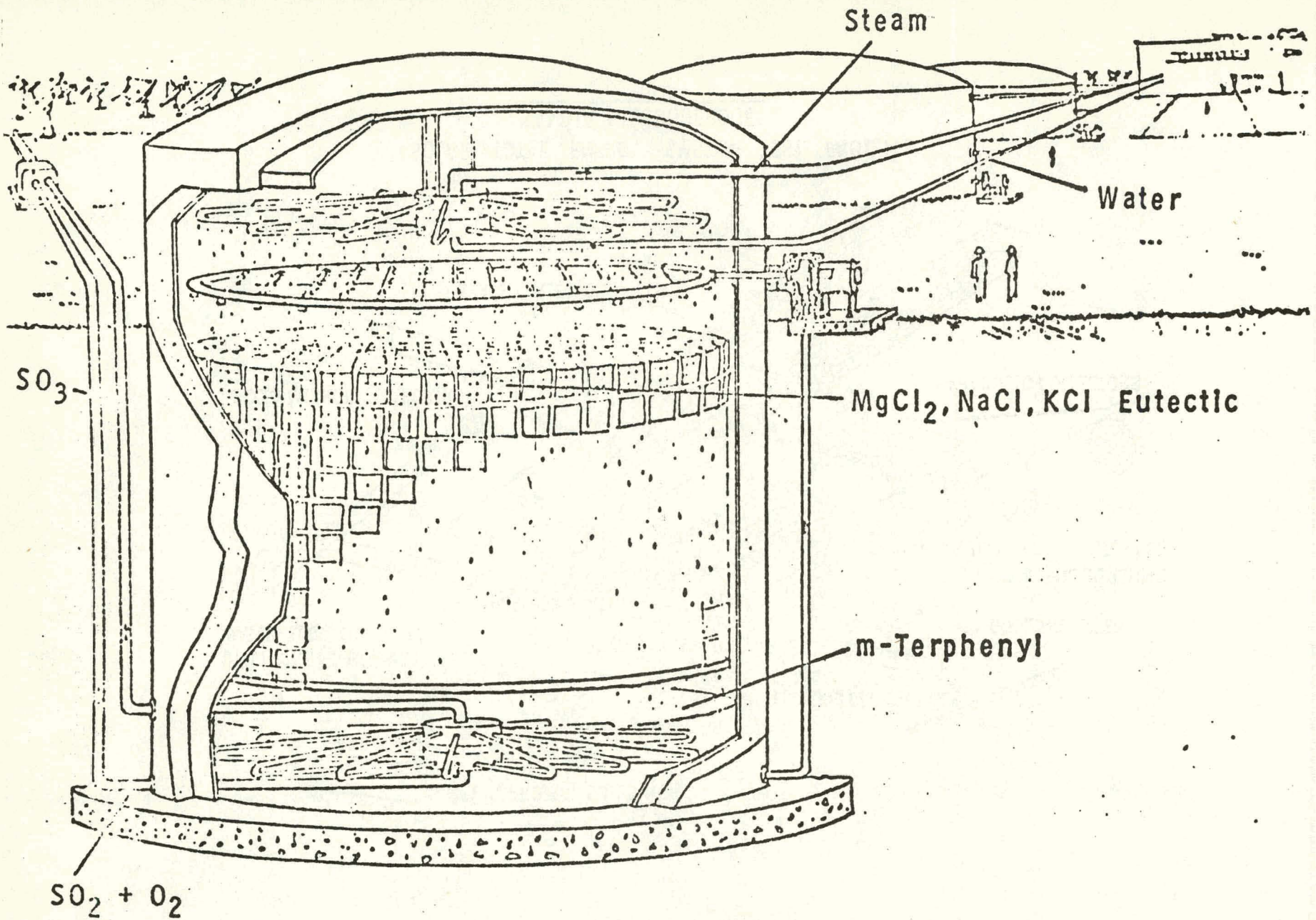

ENERGY STORAGE / BOILER TANK CONCEPT

FIGURE 12

Paper 1-6

Sandia Livermore Laboratories Energy Report
by R. W. Mar and T. T. Bramlette
(Report Number SAND77-8051, February 1978)

"THERMOCHEMICAL ENERGY STORAGE SYSTEMS - A REVIEW"
PRESENTED BY T. BRAMLETTE

(Following report submitted as paper)

Thermochemical Energy Storage Systems - A Review

(To be published in *Solar Energy Handbook*)

R. W. Mar, T. T. Bramlette

Prepared by Sandia Laboratories, Albuquerque, New Mexico 87115
and Livermore, California 94550 for the United States Department
of Energy under Contract AT (29-1)-789.

Printed February 1978



Sandia Laboratories
energy report

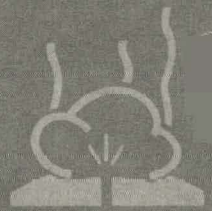
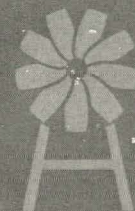
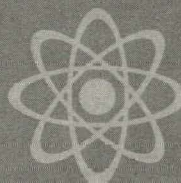
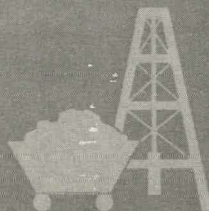
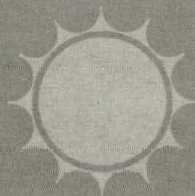

Issued by Sandia Laboratories, operated for the United States Department of Energy by Sandia Corporation.

NOTICE

This report was prepared as an account of work sponsored by the United States Government. Neither the United States nor the United States Department of Energy, nor any of their employees, nor any of their contractors, subcontractors, or their employees, makes any warranty, express or implied, or assumes any legal liability or responsibility for the accuracy, completeness or usefulness of any information, apparatus, product or process disclosed, or represents that its use would not infringe privately owned rights.

dyf

SAND77-8051
Unlimited Release
Printed February 1978

THERMOCHEMICAL ENERGY STORAGE SYSTEMS - A REVIEW

Raymond W. Mar
Exploratory Chemistry Division I, 8313

and

T. Tazwell Bramlette
Solar Technology Division, 8131
Sandia Laboratories

ABSTRACT

This report reviews the characteristics of thermochemical storage systems, analyzes the present state-of-the-art of the relevant technical disciplines, and presents some potential solar storage applications. The material has been prepared as an invited contribution to the Solar Energy Handbook, W. C. Dickinson and P. N. Cheremisinoff, eds., to be published by Marcel-Decker.

TABLE OF CONTENTS

	<u>Page</u>
I. Introduction	11
A. Characteristics of Thermochemical Energy Storage and Transport Systems	11
B. Current State-of-the-Art Analysis	12
II. Background	15
A. Thermodynamics of Reactions	15
B. Candidate Reactions	19
III. Application of Reversible Chemical Reactions	25
IV. Review of Current Activities	33
A. System Studies Activities	33
B. Technology Development Activities	33
C. System Development Activities	42
V. Summary and Conclusions	43
References	45

ILLUSTRATIONS

<u>Figure</u>		<u>Page</u>
1.	Technical disciplines necessary to the development of energy storage systems.	14
2.	Dependence of turning temperature T_{eq}° on pressure for various candidate reactions.	18
3.	Equilibrium conversion of SO_3 .	20
4.	Thermochemical energy storage concept based on the reaction $AB = A + B$.	26
5.	An endothermic reaction process diagram for a thermal energy storage system based on the SO_3/SO_2 reaction (Reference 6).	27
6.	An exothermic reaction process diagram for a thermal energy storage system based on the SO_3/SO_2 reaction (Reference 6).	28
7.	Closed-loop chemical heat pipe based on the reaction $A + B = C + D$.	29
8.	Chemical heat pump storage system based on the reactions $AB = A + B$ and $BC = B + C$.	31
9.	Sulfuric acid/water thermal energy storage system (courtesy of the Rocket Research Company).	32
10.	Forward and reverse reaction rate data for the reaction $CaCl_2 \cdot 8NH_3 = CaCl_2 \cdot 4NH_3 + 4NH_3$ (Reference 18).	35
11.	Forward and reverse reaction rate data for the reaction $MgCl_2 \cdot 2NH_3 = MgCl_2 \cdot NH_3 + NH_3$ (Reference 18).	36

TABLES

<u>Table</u>		<u>Page</u>
I.	Potential Candidate Reactions (Catalyzed)	22
II.	Potential Candidate Reactions (Gas/Solid)	23
III.	Potential Candidate Reactions (Liquid/Gas)	24

THERMOCHEMICAL ENERGY STORAGE SYSTEMS - A REVIEW

I. Introduction

Thermal energy can be stored in three forms: (1) as sensible heat, (2) as latent heat of transitions, or (3) as chemical bond energy. In the third approach, energy, when available, is used to drive an energy-consuming (endothermic) reaction; and energy is withdrawn from storage by reversing the reaction, thus effecting the energy-releasing (exothermic) reaction. Since thermochemical energy storage technologies are presently at an embryonic stage of development, one cannot seriously consider such systems for current use.

The purpose of this report is to review the state-of-the-art of thermochemical technologies. Current research and development activities will be summarized, problem areas identified, and the future prospects of varied chemical systems and applications discussed.

Specifically excluded from consideration in the present discussion are electrochemical, photochemical, and radiochemical reactions. This chapter deals solely with reactions in which thermal energy is stored and released as a consequence of net changes in chemical bond energy; therefore the term "thermochemical" is used.

A. Characteristics of Thermochemical Energy Storage and Transport Systems

The characteristics which are unique to thermochemical systems when compared to sensible and latent heat systems, are:

High Energy Densities - Thermochemical storage systems have energy storage densities (based on either mass or volume) ranging from about a factor of two to more than an order of magnitude greater than is possible with sensible and latent heat systems.

Ambient Storage - Energy storage at ambient temperatures is possible for thermochemical systems; i. e., chemical reactants and products can be cooled to and stored at ambient temperatures. The ability to

store at ambient temperatures and still discharge at high temperatures has obvious advantages: chemical interactions between the media and storage container materials are avoided, insulation requirements are eliminated, overall system heat losses are reduced, and potential environmental impact problems (e. g., those resulting from storing copious quantities of hot material) are avoided. On the other hand, there is a penalty associated with storage at ambient temperatures: sensible and possibly latent heats are rejected upon cooling the products to ambient. This reject heat may not necessarily be lost, however, as it may be possible to recover it elsewhere in the chemical cycle.

Long-Term Storage - In ambient storage, long-term storage with little or no degradation is possible, thus making seasonal or extended storage applications feasible.

Transportability - Chemical reactions can be selected so that the products and reactants are easily transportable, e. g., as gases in a pipeline. Therefore, the endothermic and exothermic reactors can be physically separated by long distances.

Low-Energy Related Costs - The cost of an energy storage system can generally be divided into two categories: power costs and energy costs. The power-related costs are those associated with reactors, heat exchangers, etc.; whereas energy related costs are associated with raw materials costs, storage tank costs, etc., and are generally low for thermochemical systems.

While these characteristics may be considered advantages for many applications, they must be weighed against the following potential drawbacks:

Furthest From State-of-the-Art - Thermochemical technologies are the least developed; and considerable amounts of time, money, and effort are required to develop thermochemical systems to commercialization.

System Complexity - Thermochemical systems will probably be quite complex when compared with sensible and latent heat systems. Not only will individual components be complex, but interactions between various components will be needed in order to achieve acceptable total system efficiencies.

B. Current State-of-the-Art Analysis

The technical disciplines important to the development of energy storage systems are given in Figure 1. Also listed for each discipline are

problem areas which are generally unresolved at this time and which must be solved if a thermochemical storage concept is to be developed successfully. A general discussion of the state of the art of these technical disciplines is given below to put thermochemical storage in the proper perspective relative to sensible and latent heat systems.

Chemistry - The heart of a thermochemical energy storage system is the reversible chemical reaction itself. Generally speaking, no such reaction is presently well enough understood to allow its immediate incorporation into a storage system. Consequently, a considerable amount of research and development is required to characterize any potentially useful reaction with respect to such parameters as reaction rates, side reactions, reversibility, cyclability, long-term performance, reproducibility, reliability, and impurity effects. For catalyzed reactions, moreover, additional questions concerning catalyst lifetime, degradation, and poisoning must be addressed.

Heat Transfer - Equally important to the thermochemical energy storage system are the chemical reactors and process-stream heat exchangers. Generally speaking, design techniques are available for predicting system performance. What is lacking, however, is information regarding such things as the thermophysical and transport properties of the various constituents of the chemical system and the effects of catalyst performance, reaction kinetics, long-term cyclic operation, to name a few, on heat transfer. Small-scale experiments are required to verify theoretical predictions before large-scale systems are designed and constructed.

Materials - Material compatibility and corrosion problems can be significant, the degree depending upon the temperatures of the storage operation and the chemicals involved. Ambient storage, however, mitigates the material problems to the extent that the corrosive conditions may now be confined to a fairly small portion of the total system. Unfortunately, the highest temperatures (and therefore the most corrosive environment) are generally found in the most complex and expensive components of the system, viz., the reactor and heat exchangers.

Chemical Engineering - Almost all thermochemical reaction cycles for storage or transport applications contain steps which are potentially wasteful of energy and the net result is a much reduced effective energy density. As an example, consider the reaction



which has an attractively large heat of reaction of 1590 J/g. However, if one considers the fact that 594 J/g are lost in the condensation of

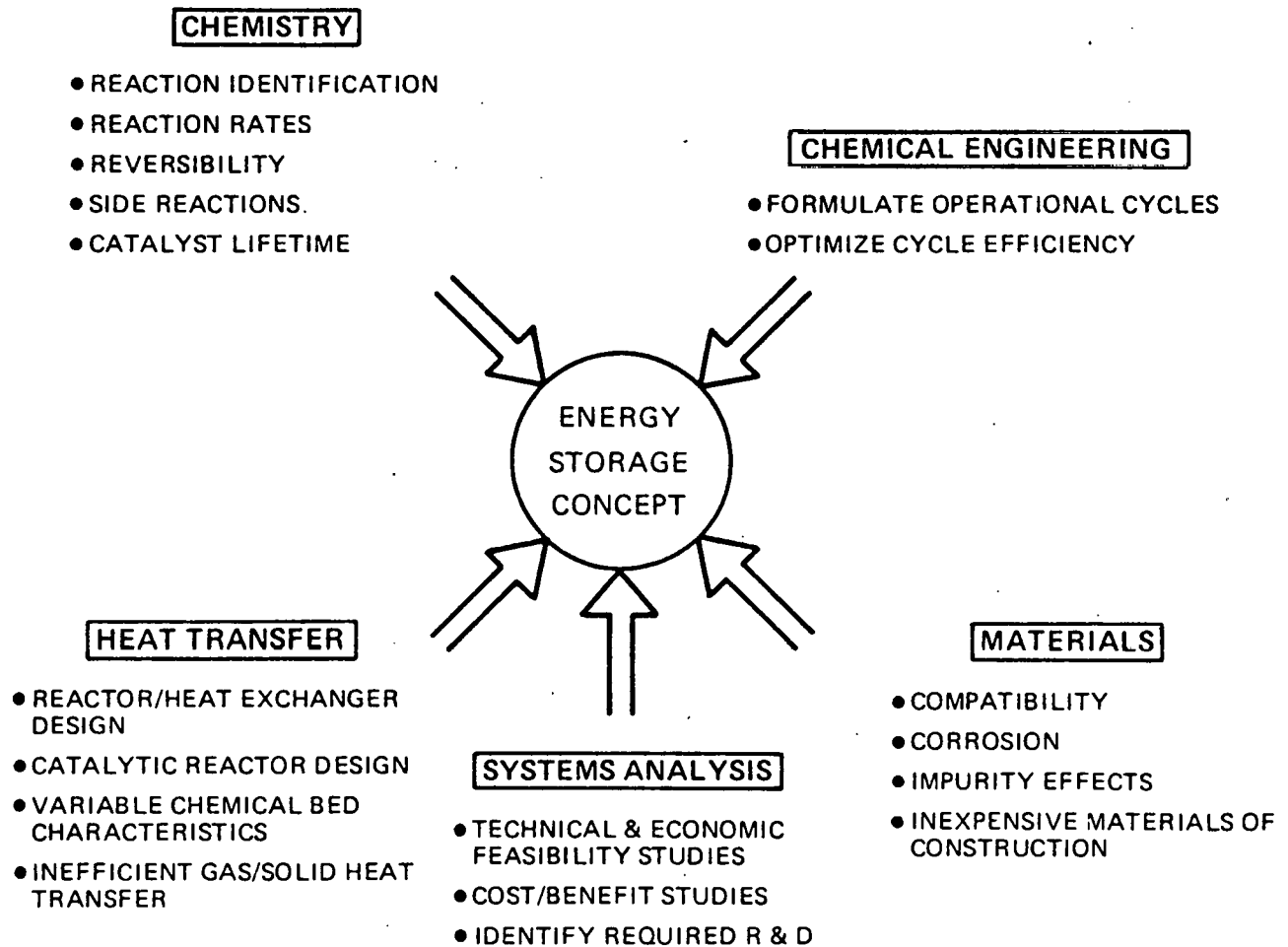

Figure 1. Technical disciplines necessary to the development of energy storage systems.

H₂O and the sensible heats associated with H₂O and CaO, the net energy density is only 996 J/g. The solution, of course, is to use the heat of condensation and sensible heats for secondary purposes; therein lies one of the technical challenges that must be met if the thermochemical system is to be used to its best advantage. Operational cycles must also be optimized, and the recovery and re-use of potential rejected energies are necessities for the development of economically viable thermochemical energy storage and transport systems.

Systems Analysis - In addition to the fundamental investigations described above, systems analyses must be performed. These studies are required to establish the technical and economic feasibility of a proposed concept, to identify required research, and to establish the relative merits of the proposed system as compared with competing technologies. These studies must continue throughout the development process in order to filter in new information as it becomes available and to ensure that the concepts being developed will be technically and economically viable.

In summary, thermochemical technology is at a very early stage of development, and much is needed in the way of technology development in each of the five technical disciplines shown on Figure 1 before one can accurately assess the potential of thermochemical techniques, let alone develop thermochemically based concepts to the point of commercialization. Current efforts (described in greater detail below) are directed at fairly specific problems in each discipline. Very little work is going on which can be considered systems development.

II. Background

A. Thermodynamics of Reactions

" . . . any reaction or change of state that appears with increasing temperature on an equilibrium temperature-composition phase diagram must necessarily occur with the absorption of heat and a positive entropy change. "1

This statement is as valid as the First and Second Laws of Thermodynamics. When applied to thermochemical reactions of interest for energy storage applications, it indicates that they must necessarily have positive enthalpy and entropy changes when written in the energy charge (endothermic) direction. Furthermore, the endothermic process will necessarily take place at a temperature greater than the exothermic process (unless one does additional work to the system).

Since thermodynamics forms the basis from which reactions are selected, it is appropriate to review briefly the relevant thermochemical quantities and examine their interdependence. For the sake of simplicity, assume standard states for all reactants and products, and $\Delta C_p = 0$ for the reaction. One can then define a temperature T_{eq}° as

$$T_{eq}^\circ = \Delta H_{298}^\circ / \Delta S_{298}^\circ \quad (2)$$

where ΔH_{298}° and ΔS_{298}° are the enthalpies and entropies of reaction at 298 K. If $T > T_{eq}^\circ$, the endothermic reaction proceeds; for $T < T_{eq}^\circ$, the exothermic reaction proceeds. The enthalpy is essentially fixed if one selects (1) the storage application and (2) the class of reaction. The former determines T_{eq}° , since the source and end-use temperatures are defined, and the latter fixes ΔS_{298}° , since entropy changes are essentially constant for a class of reactions. Therefore, while one generally seeks to maximize energy density, a realistic limit is set. Conversely, if one assumes a specific application (fixes T_{eq}°) and a desired energy density (fixes ΔH_{298}°), then the required ΔS_{298}° is fixed and one is restricted to a specific class of reactions. One also notes that given a class of reactions, as the storage temperature increases so does the theoretical energy storage density.

Inasmuch as the interplay between ΔH_{298}° , ΔS_{298}° , and T_{eq}° has been discussed, it is appropriate to explore factors which govern their magnitudes. The change in entropy depends mainly upon the phase characteristics of the reactants and products, and generalizations can be made relating the magnitude of the entropy change to the class of reaction. Some familiar examples are Trouton's rule (entropy of vaporization at the normal boiling point is ~ 92 J/K/mole) and Richard's rule (the entropy of fusion of metals is ~ 9.2 J/K/g. at.). The following reaction characteristics are associated with positive entropy production: net increase in number of molecules, net increase in molecular complexity, net increase in number of gaseous species, and an increase in number of liquid species. It is beyond the scope of this review to detail the methods used to estimate entropy changes, but a few quantitative remarks are useful to help orient the reader. When reactants and products are all solids, the entropy change will be within a few entropy units of zero. The greatest entropy change is associated with the production of gaseous species (e. g., a net increase of one diatomic gas molecule is associated with an entropy change of ~ 170 J/K/mole gas).

The magnitude of the enthalpy change depends primarily upon the molecular bond chemistry, and is a direct measure of the net change in bond energy. Also, T_{eq}° is a measure of bond energy; that is, the greater the energy, the higher is the temperature required to cause bonding re-arrangements.

The concept of a singular turning temperature T_{eq}° is a reasonable simplification when one considers reactions which do not involve gaseous species. However, if gaseous products are formed during the endothermic reaction, the magnitude of T_{eq}° is affected to the extent that the equilibrium constant K_{eq} depends on pressure

$$T_{eq} = \frac{\Delta H_{298}^{\circ}}{\Delta S_{298}^{\circ} + \ln K_{eq}(P)} \quad (3)$$

The magnitude of the effect of pressure is illustrated on Figure 2, where T_{eq} is plotted against pressure P for several candidate reaction systems.

Equations (2) and (3) lose their significance when reactions which involve both gaseous reactants and products are analyzed, in which case the reactions typically reverse directions gradually over a range of temperatures. As an illustration of the thermodynamics involved, consider the reaction



When we assume the system to be charged initially with n moles of SO_3 , if x moles of O_2 form, the amounts of SO_3 and SO_2 in a closed system at temperature T and total pressure P_T are $(n - 2x)$ and $2x$, respectively. The partial pressures of SO_3 , SO_2 , and O_2 are therefore given by:

$$P_{SO_3} = \frac{(n - 2x)}{(n + x)} P_T \quad (5)$$

$$P_{SO_2} = \frac{2x}{(n + x)} P_T \quad (6)$$

$$P_{O_2} = \frac{x}{(n + x)} P_T \quad (7)$$

The free energy of reaction (with gas ideality assumed) is given by

$$\Delta F_T = \Delta F_T^{\circ} + RT \ln (P_{SO_2}^2 P_{O_2} / P_{SO_3}^2) \quad (8)$$

and at equilibrium, $\Delta F_T = 0$. Substituting Equations (5), (6), and (7) into Equation (8), one derives an expression relating P_T , T , and x :

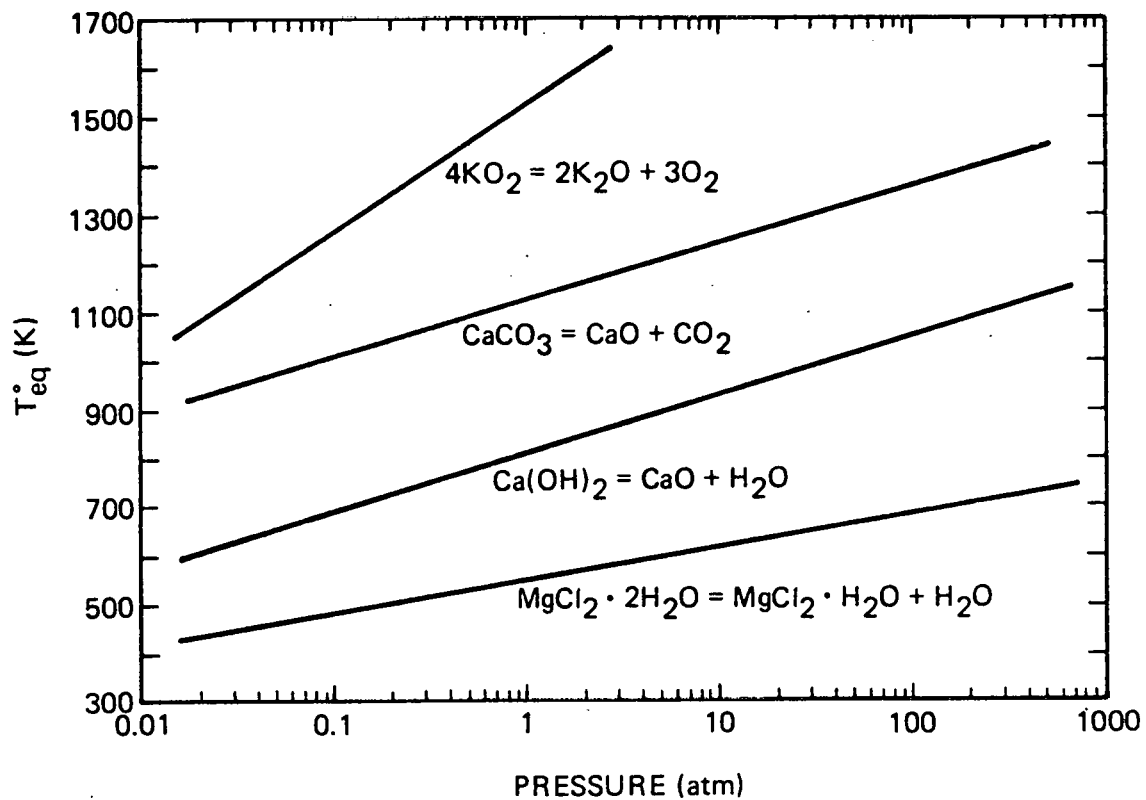

Figure 2. Dependence of turning temperature T_{eq}° on pressure for various candidate reactions.

$$\ln \frac{(n+x)(n-2x)^2}{4x^3} = \ln P_T + \frac{\Delta F_T^\circ}{RT} \quad (9)$$

The solution of Equation (9) is given in Figure 3, where x is represented as the degree of SO₃ dissociation. Note that the reaction 2SO₃ = 2SO₂ + O₂ reverses direction (fraction SO₃ converted varies from 0.1 to 0.9) over a temperature range of ~450 K. Furthermore, as the pressure increases, the curves are displaced to higher temperatures.

B. Candidate Reactions

Selection Criteria--When one is selecting a thermochemical reaction for use in a storage application, the criteria which must be considered include

Thermodynamic Requirements - Suitable values for ΔH and T, such that operational temperatures and desired energy densities are met.

Reversibility - Reactions must be reversible with no significant side reactions or changes in reaction rates with time.

Reaction Rates - The rates of the forward and reverse reactions must be rapid enough to satisfy energy input and output requirements.

Controllable - One must be able to turn reactions on and off as required.

Ease of Storage - The reactants and products must be conducive to simple and inexpensive storage.

Safe - The chemicals should not pose insurmountable safety hazards due to chemical corrosivity, toxicity, flammability, etc.

Inexpensive and Available - The chemicals must be readily available and reasonably inexpensive. Specific cost requirements, however, can only be determined by a detailed economic analysis for the specific application.

Classification of Reactions--Because the number of reversible chemical reactions is virtually endless, it is helpful to think within a systematic classification framework. One approach, which is adopted here, is to consider the way in which reactions are controlled. Given the endothermic reaction, how can one prevent energy degradation and loss through back reaction? Three methods can be used: (1) catalyzed reactions, (2) separation of products, and (3) thermal quenching.

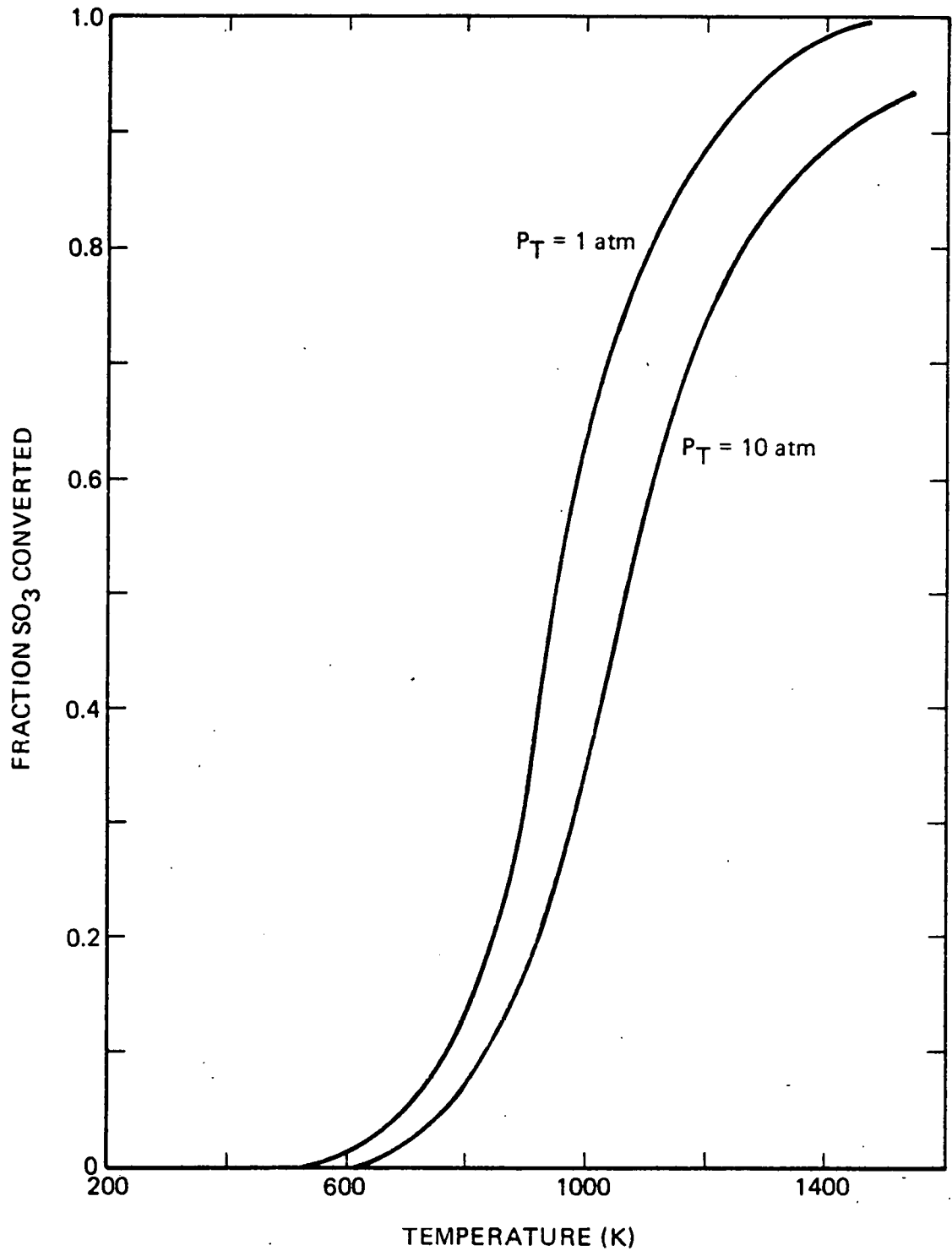

Figure 3. Equilibrium conversion of SO₃.

Products of endothermic catalyzed reactions can be stored indefinitely in the absence of the appropriate catalyst for the reverse reaction. The recovery (discharge) of the stored energy can be effected by passing the chemicals over the catalyst in the exothermic reactor heat exchanger.

The back reaction of the products may also be prevented by physically separating them, and whereas homogeneous reactions do not lend themselves to easy separation, heterogeneous reactions do. The latter can be grouped according to the nature of the species in the reactor/heat exchanger component; thus gas/solid, gas/liquid, and liquid/solid reactions are possible. However, because of the entropy requirements discussed earlier, one is generally not interested in liquid/solid interactions.

It is also possible in theory to quench the products of the endothermic reaction to metastable states by rapid heat removal. The exothermic recombination of the products must be slow enough to allow quenching to ambient, and yet the kinetics must be fast enough to provide adequate energy discharge when required. This approach, however, is not realistic; it is discussed simply for the sake of completeness.

In summary, it is convenient to categorize candidate reactions into three groups:

1. Catalyzed reactions
2. Solid/gas decomposition reactions
3. Liquid/gas decomposition reactions

Potential Chemical Reactions--Several investigators have attempted to generate comprehensive lists of potential candidate reactions,²⁻⁵ some of which are listed in Tables I-III, where they are categorized by reaction class and ordered according to the T_{eq}° . No attempt is made here to critically assess the merits and drawbacks associated with each. These tables are by no means complete, and technically and economically viable reactions are no doubt missing. An asterisk is used to denote reactions which are currently under investigation for use in energy storage or transport applications.

TABLE I
POTENTIAL CANDIDATE REACTIONS (CATALYZED)

REACTION	T_{eq}° (K)
$C_2H_6(g) = C_2H_4(g) + H_2(g)$	1136
* $2SO_3(g) = 2SO_2(g) + O_2(g)$	1035
* $CH_4(g) + H_2O(g) = CO(g) + 3H_2(g)$	961
$CH_4(g) + CO_2(g) = 2CO(g) + 2H_2(g)$	961
$2H_2O(g) + 2Cl_2(g) = 4HCl(g) + O_2(g)$	896
$COCl_2(g) = CO(g) + Cl_2(g)$	801
$2NO_2(g) = 2NO(g) + O_2(g)$	778
* $C_6H_{12}(g) = C_6H_6(g) + 3H_2(g)$	568
$2NH_3(g) = N_2(g) + 3H_2(g)$	466
$CH_3OH(g) = CO(g) + 2H_2(g)$	415

*TECHNOLOGIES PERTINENT TO THIS REACTION ARE CURRENTLY UNDER DEVELOPMENT.

TABLE II
POTENTIAL CANDIDATE REACTIONS (GAS/SOLID)

REACTION ^(a)	T _{eq} ^o (K)
BaCO ₃ (s) = BaO(s) + CO ₂ (g)	1566
MgSO ₄ (s) = MgO(s) + SO ₃ (g)	1469
Li ₂ CO ₃ (s) = Li ₂ O(s) + CO ₂ (g)	1387
ZnSO ₄ (s) = ZnO(s) + SO ₃ (g)	1373
CaCO ₃ (s) = CaO(s) + CO ₂ (g)	1110
*M ^{II} (OH) ₂ (s) = M ^{II} O(s) + H ₂ O(g)	530–1000
MgCO ₃ (s) = MgO(s) + CO ₂ (g)	670
2LiH(s) = 2Li(l) + H ₂ (g)	645
MgH ₂ (s) = Mg(s) + H ₂ (g)	560
*NH ₄ X(s) = NH ₃ (g) + HX(g)	500–650
*MgCl ₂ · xNH ₃ (s) = MgCl ₂ · yNH ₃ (s) + (x–y)NH ₃ (g)	415–550
*CaCl ₂ · xNH ₃ (s) = CaCl ₂ · yNH ₃ (s) + (x–y)NH ₃ (g)	310–460
*RENi ₅ H ₆ (s) = RENi ₅ (s) + 3H ₂ (g)	215

* TECHNOLOGIES PERTINENT TO THIS REACTION ARE CURRENTLY UNDER DEVELOPMENT

(a) M^{II} = ALKALINE EARTH ELEMENT

X = HALOGEN

RE = RARE EARTH ELEMENT

TABLE III
POTENTIAL CANDIDATE REACTIONS (LIQUID/GAS)

REACTION	T_{eq}° (K)
$2\text{NaOH}(l) = \text{Na}_2\text{O}(s) + \text{H}_2\text{O}(g)$	1700
$2\text{LiOH}(l) = \text{Li}_2\text{O}(s) + \text{H}_2\text{O}(g)$	1000
$*\text{NH}_4\text{HSO}_4(l) = \text{NH}_3(g) + \text{H}_2\text{O}(g) + \text{SO}_3(g)$	738
$\text{H}_2\text{SO}_4(l) = \text{H}_2\text{O}(g) + \text{SO}_3(g)$	615
$2\text{KO}_2(l) = \text{K}_2\text{O}_2(l) + \text{O}_2(g)$	515
$*\text{H}_2\text{SO}_4(\text{dilute}) = \text{H}_2\text{SO}_4(\text{concen.}) + \text{H}_2\text{O}(g)$	—
$\text{NaOH}(\text{dilute}) = \text{NaOH}(\text{concen.}) + \text{H}_2\text{O}(g)$	—
$*\text{NH}_4\text{Cl} \cdot 3\text{NH}_3(l) = \text{NH}_4\text{Cl}(s) + 3\text{NH}_3(g)$	~320

*TECHNOLOGIES PERTINENT TO THIS REACTION ARE CURRENTLY UNDER DEVELOPMENT.

III. Applications of Reversible Chemical Reactions

The previous sections have dealt with the potential advantages and state-of-the-art of reversible chemical reactions, and have discussed factors one must consider when selecting a chemical reaction for a particular application. This section will describe the principles of operation and the major physical characteristics of various storage systems which are based upon reversible chemical reactions. There are three major potential applications of reversible chemical reactions in solar energy systems: (1) thermal energy storage, (2) energy transport, and (3) heat pumping.

Conceptually, a thermal energy storage system may be represented as in Figure 4 which illustrates the use of a hypothetical reaction $AB = A + B$. The essential elements of the system are storage vessels for the reactant and product chemicals, and endothermic and exothermic heat exchanger reactors. During the energy storage step, AB is transported to the endothermic reactor where heat is provided from an energy source to decompose AB into A and B. The products are then physically separated and placed in storage tanks. During energy discharge, A and B are recombined in the exothermic reactor, where heat is withdrawn for use. The product of the exothermic reaction is then placed in storage, ready for the operation to be repeated.

In reality, however, the thermal energy storage systems based upon reversible chemical reactions are far more complex than those depicted in the simple schematics of Figure 4. Figures 5 and 6 present one possible configuration for a system based upon the reaction

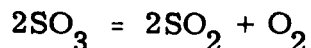

which is coupled with an energy source which provides 1173 K (900°C) helium.⁶ Figure 5 depicts the endothermic end of the storage system, and Figure 6, the exothermic end. As may be seen, this system consists of a number of reactors, condensers, vaporizers, heat exchangers, separation columns, compressors, and storage tanks. To maximize efficiency and cost effectiveness, great care must be taken in integrating the storage system with the rest of the energy conversion system.

The basic features of a chemical heat pipe are illustrated in Figure 7, with the hypothetical reaction $A + B = C + D$ used as an example. The chemical heat pipe may be used to transport solar thermal energy over long distances to an end user or to other parts of the solar energy system as is required in distributed systems. The components comprising the system are essentially identical to those described in Figure 4, with the storage tanks replaced by pipelines through which the reactants and products are transmitted and possibly stored. As with the thermal storage system discussed earlier, actual systems are far more complex, and again, great care must be taken to integrate the heat pipe into the total system.

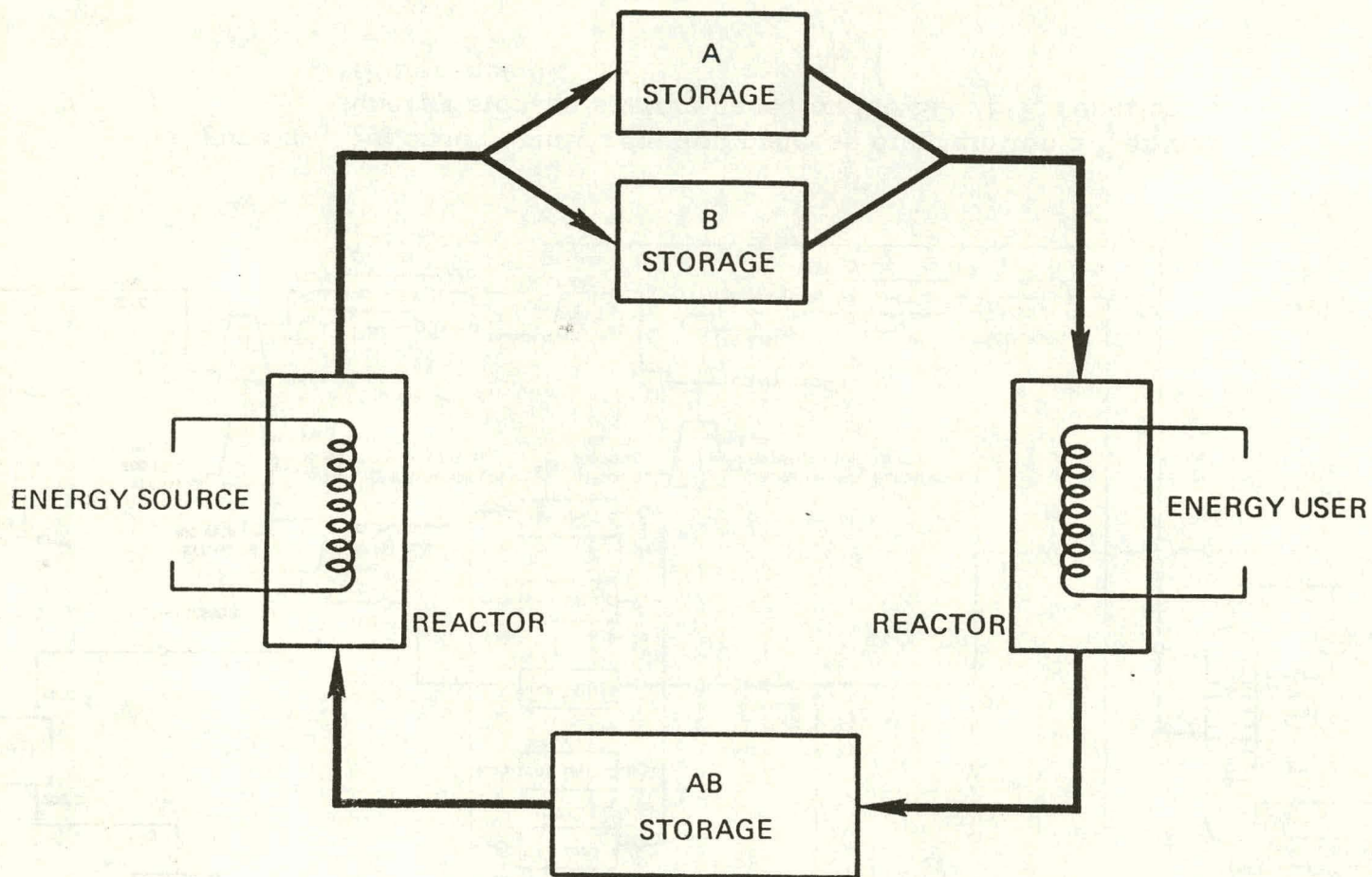

Figure 4. Thermochemical energy storage concept based on the reaction $AB = A + B$.

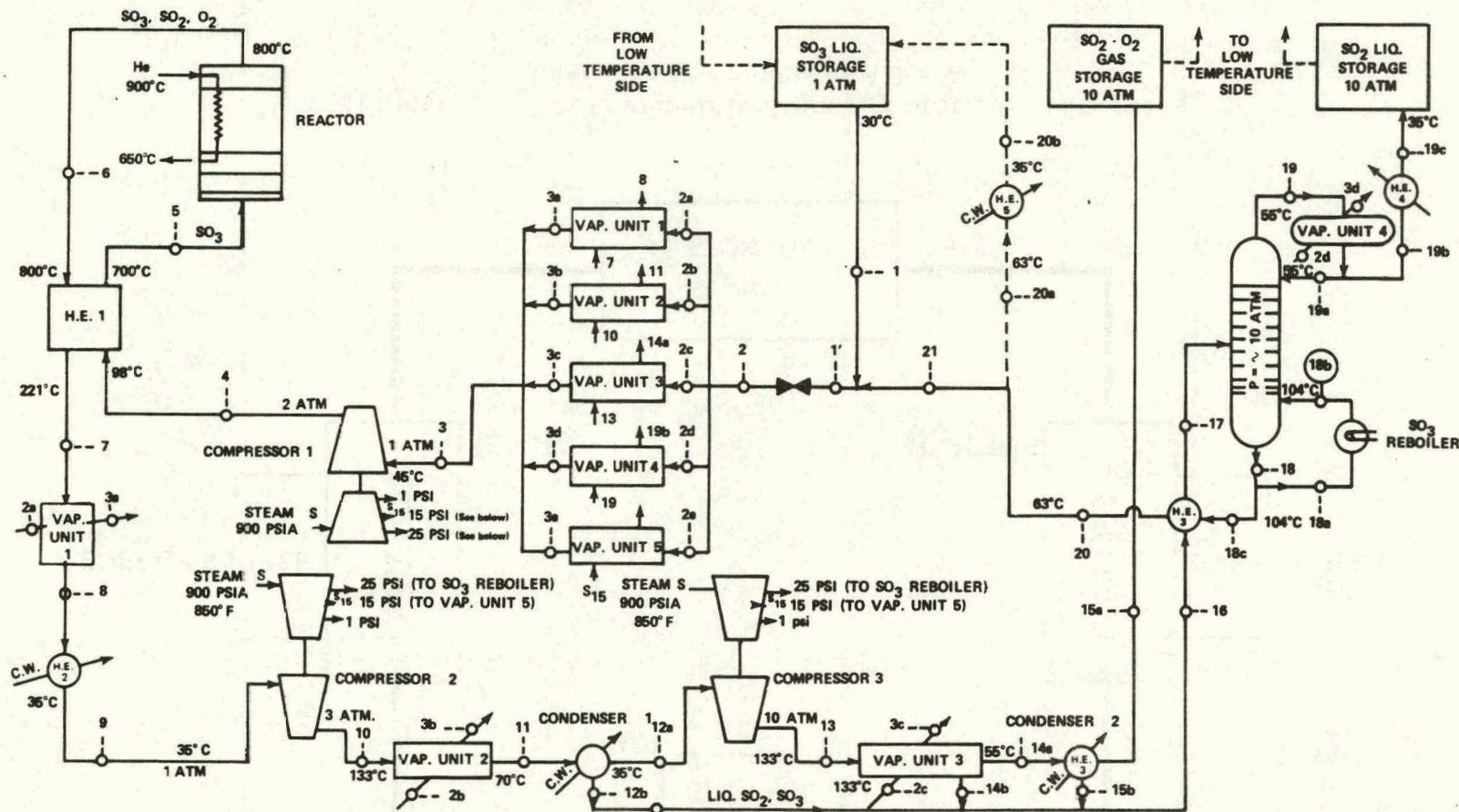

Figure 5. An endothermic reaction process diagram for a thermal energy storage system based on the SO_3/SO_2 reaction (Reference 6).

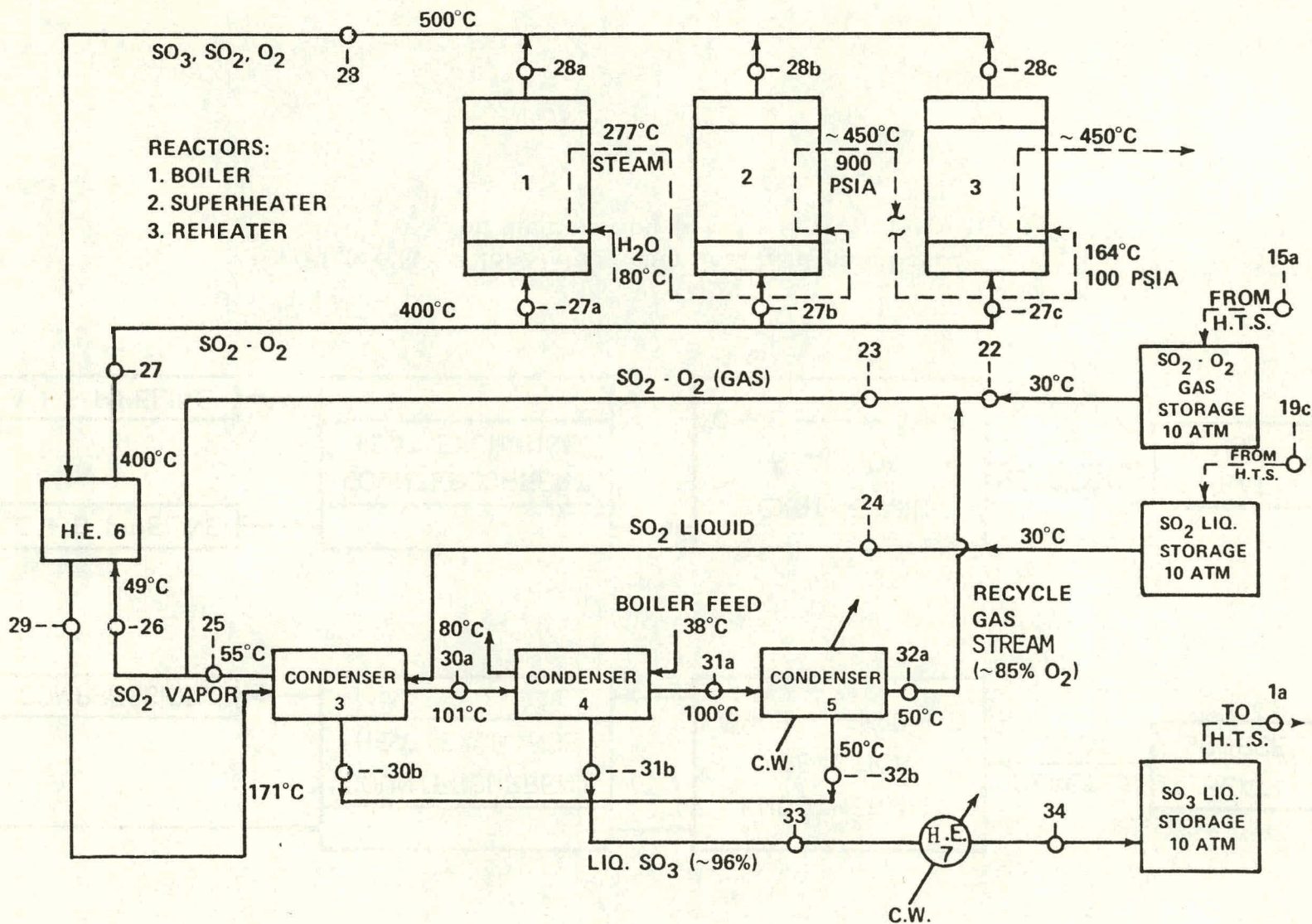

Figure 6. An exothermic reaction process diagram for a thermal energy storage system based on the SO_3/SO_2 reaction (Reference 6).

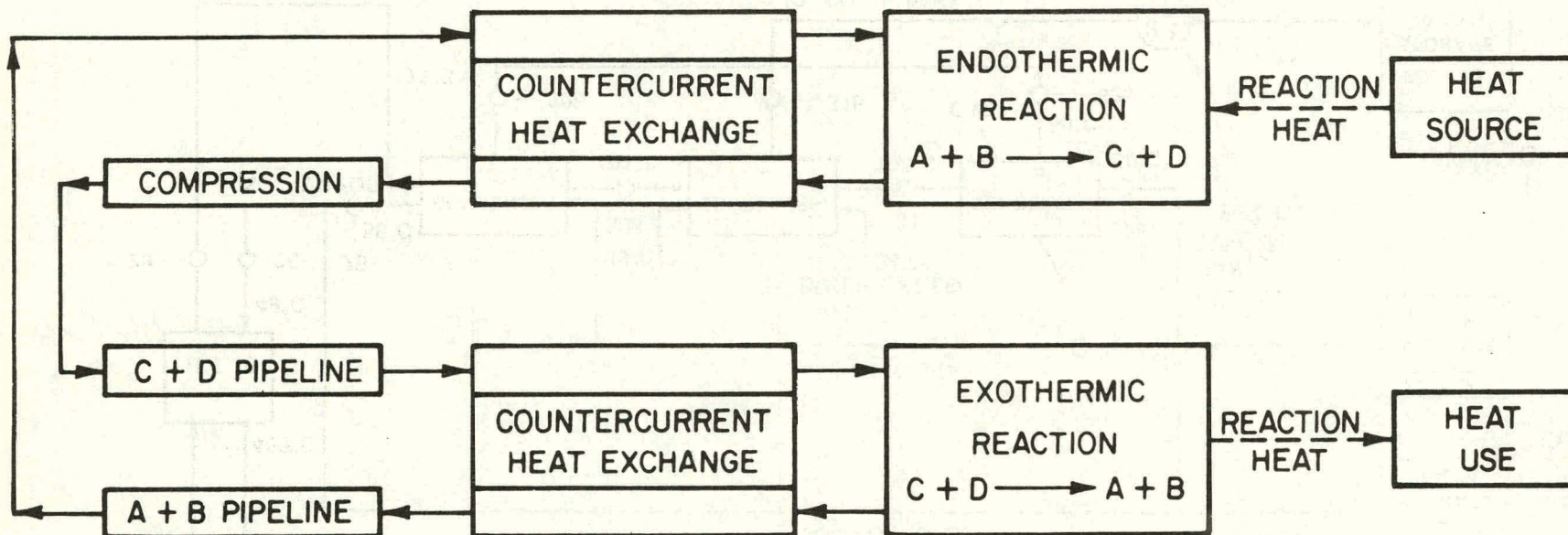

Figure 7. Closed-loop chemical heat pipe based on the reaction $A + B = C + D$.

The third major use of chemical reactions in solar applications is as a chemical heat pump. The chemical reactions required for such a storage system are represented illustratively by $AB = A + B(g)$ and $CB = C + B(g)$ [a special case is where the latter reaction is simply the vaporization of B, $B(l \text{ or } s) = B(g)$]. Further, these two reactions must have a common vapor species, $B(g)$ in this case. The reactions are selected so that there is a significant difference in enthalpy of reaction, for it is this difference which accounts for the storage feature of a chemical heat pump. The two reactions must be selected so that their respective pressure/temperature relationships are compatible with the intended operating conditions. The components of a chemical heat pump system (high-temperature and low-temperature reactor heat exchangers, which may be fixed, moving, or fluidized beds, and a connecting pipeline) are illustrated in Figure 8. Also shown is the pressure/temperature relationship for both the high-temperature and low-temperature reactions. During charge, energy is absorbed by the high-temperature unit, and AB is decomposed into A and B(g) and the latter is transported to the low-temperature unit where it reacts with C to form BC. Heat is released at the low-temperature unit, where it is either used or rejected. The charge sequence is shown on Figure 8 by the solid arrow. During energy discharge, energy is absorbed by the low-temperature unit, BC decomposes, and gaseous B is transported over to the high-temperature unit. There it combines exothermically with A to form AB. The discharge process, shown on Figure 8 by the dashed arrow, may be used for either heating or cooling. For heating, energy is absorbed from the environment in the low-temperature reactor, and heat is rejected from the high-temperature component to the indoors. For cooling, heat is withdrawn from indoor air at the low-temperature reactor and rejected to the outdoor environment through the high-temperature component.

One specific example of a chemical heat pump storage system currently under development is the sulfuric acid scheme,⁷ where AB is dilute sulfuric acid, A is concentrated sulfuric, B(g) is water vapor, and BC is condensed water. Figure 9 presents a photograph of a subscale (10^9 J) experiment which is currently under development and test. Shown on this photograph are the acid and water storage tanks, the reflux column to prevent acid carryover to the water tank, input/output heat exchangers, and the ducting for water vapor transport.

This brief discussion has presented some of the potential solar storage applications of reversible chemical reactions. The following section reviews the status of the various investigations underway which are concerned with developing and implementing these concepts.

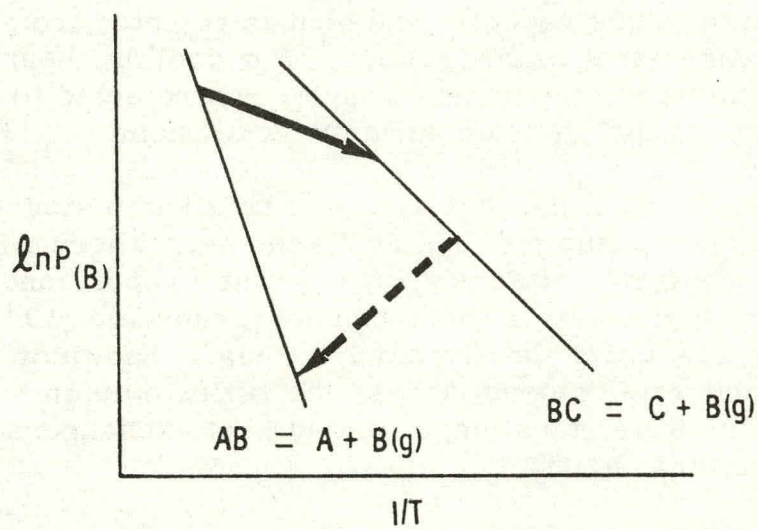
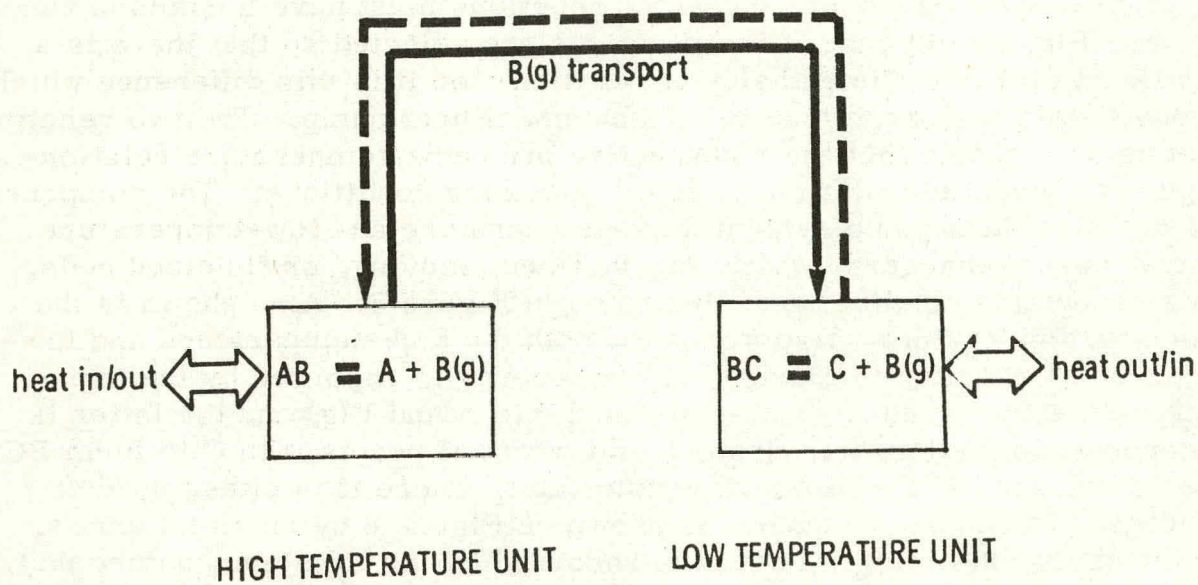

Figure 8. Chemical heat pump storage system based on the reactions $AB = A + B$ and $BC = B + C$.

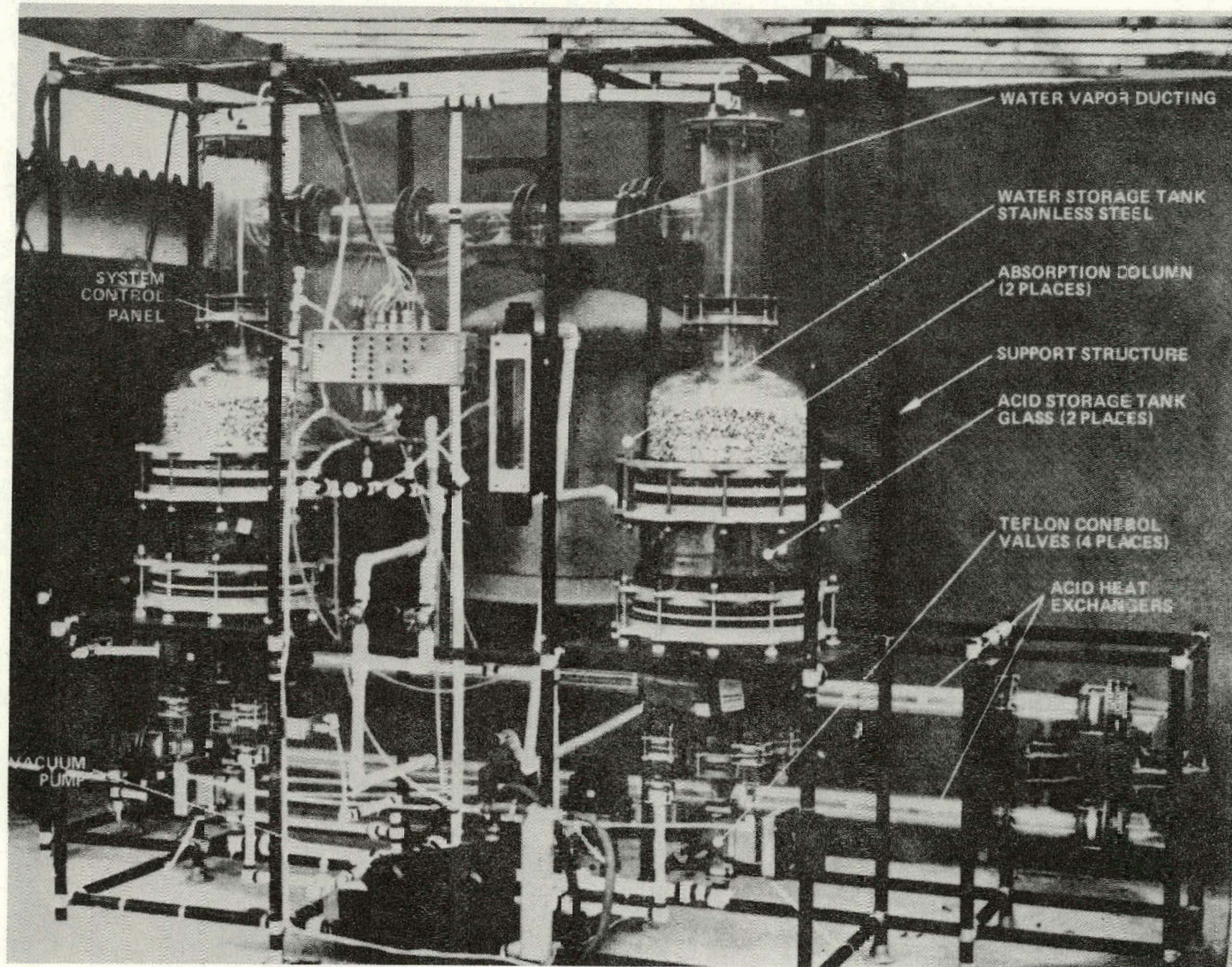

Figure 9. Sulfuric acid/water thermal energy storage system (Courtesy of the Rocket Research Company).

IV. Review of Current Activities

In this section we will briefly review all current research and development activities pertaining to thermochemical energy storage technologies relevant to solar applications which are known to the authors. System study activities will be discussed first, followed by technology development activities, and then by system development activities.

A. System Studies Activities

These activities are paper studies which explore the potential impact of thermochemical technologies in various solar applications.

Extended Storage for Solar Applications--A study is currently underway to evaluate the concept of chemical storage of solar energy on a total system basis.⁸ Technical considerations include selection of reactions or reaction sequences which may be useful for energy storage, evaluation of selected reactions on thermodynamic and kinetic bases, and preliminary design and modeling of energy storage subsystems based on these reactions. By means of a computer model of a solar-thermal power generation facility, the technical and economic feasibility of extending the solar-thermal conversion concept to include baseload power generation is being studied.

Advanced Storage Concepts for Solar Heating/Cooling--The DOE, Division of Solar Heating/Cooling has funded a study to determine the optimum role which advanced thermal storage subsystems can play in solar heating and cooling applications.⁹ To be considered are cold storage for air conditioning, cold-side storage in heat pump applications, hot storage for space heating and hot water, and air conditioning applications. The scope of advanced technologies to be considered will include thermochemical, phase change, and other advanced concepts. This study was initiated in September 1977, and at the time of this writing, conclusions were not yet available.

B. Technology Development Activities

Technology development refers to activities which are aimed at generating the basic data prerequisite to thermochemical storage system design, fabrication, and test. The bulk of the current effort is aimed at chemically characterizing potential chemical systems, although some work aimed at understanding fundamental heat-transfer characteristics is also underway. Technology development is distinguished from systems development (discussed in Section C) in that the former is "science"-oriented while the latter emphasizes "engineering" problems.

Hydrated Salts--Numerous salts form stable hydrates, but the $\text{MgCl}_2 \cdot n\text{H}_2\text{O}$ system has received the most attention to date, primarily because of its low cost and thermodynamic characteristics, which are matched with solar heating and cooling requirements. L. Greiner¹⁰ is attempting to design a chemical heat pump system based on $\text{MgCl}_2 \cdot n\text{H}_2\text{O}$ reactions. Preliminary experiments have suggested that chemical kinetics are sufficiently rapid; however, R. W. Carling¹¹ has given evidence of potential side reaction and irreversibility problems. More work is thus required to chemically characterize hydrated salt reactions before they can be seriously considered for storage applications. Uses are probably restricted to lower temperature applications, as hydrate salts are generally not stable at high temperatures.

Ammoniated Salts--Thermal energy storage and/or transport systems based on the generalized reaction

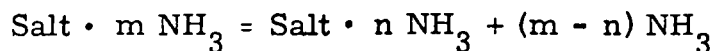

have been proposed by numerous investigators.¹²⁻¹⁷ The most promising solar-related application appears to be heating and cooling; higher-temperature applications do not appear feasible, since stable high-temperature salts are not known. The reaction kinetics for the dissociation and association of the following salts have been studied by the Martin Marietta Corporation staff:¹⁸ $\text{CaCl}_2 \cdot 8\text{NH}_3$, $\text{CaCl}_2 \cdot 4\text{NH}_3$, $\text{CaCl}_2 \cdot 2\text{NH}_3$, $\text{FeCl}_2 \cdot 6\text{NH}_3$, $\text{FeCl}_2 \cdot 2\text{NH}_3$, $\text{FeCl}_2 \cdot \text{NH}_3$, $\text{MgCl}_2 \cdot 6\text{NH}_3$, $\text{MgCl}_2 \cdot 2\text{NH}_3$, and $\text{MgCl}_2 \cdot \text{NH}_3$. Among these, the ferrous chloride ammoniate reactions did not behave reversibly, and undesirable side reactions took place. The calcium chloride salts behaved reversibly, and kinetic data for the reaction $\text{CaCl}_2 \cdot 8 \text{NH}_2 = \text{CaCl}_2 \cdot 4\text{NH}_3 + 4\text{NH}_3$ are shown in Figure 10. It is apparent that there is a significant amount of scatter in the data, suggesting potential problems if precise performance characteristics are required. The magnesium chloride salts too behaved reversibly and reproducibly; and as an example, the kinetic data pertaining to the reaction $\text{MgCl}_2 \cdot 6\text{NH}_3 = \text{MgCl}_2 \cdot 4\text{NH}_3 + 2\text{NH}_3$ are shown on Figure 11. The Martin Marietta program has advanced to a point where the characteristics of coupled reactions are being studied. A two-reactor system has been assembled, in which candidate salt pairs are being cycled; chemical behavior and energy balance data are being generated.

On the basis of the experimental work to date, it is clear that one cannot predict kinetic data from analogous reactions; each candidate reaction must be investigated on an individual basis. One must also be concerned with the presence of moisture, since it has been shown to significantly alter the kinetic characteristics of certain reactions,

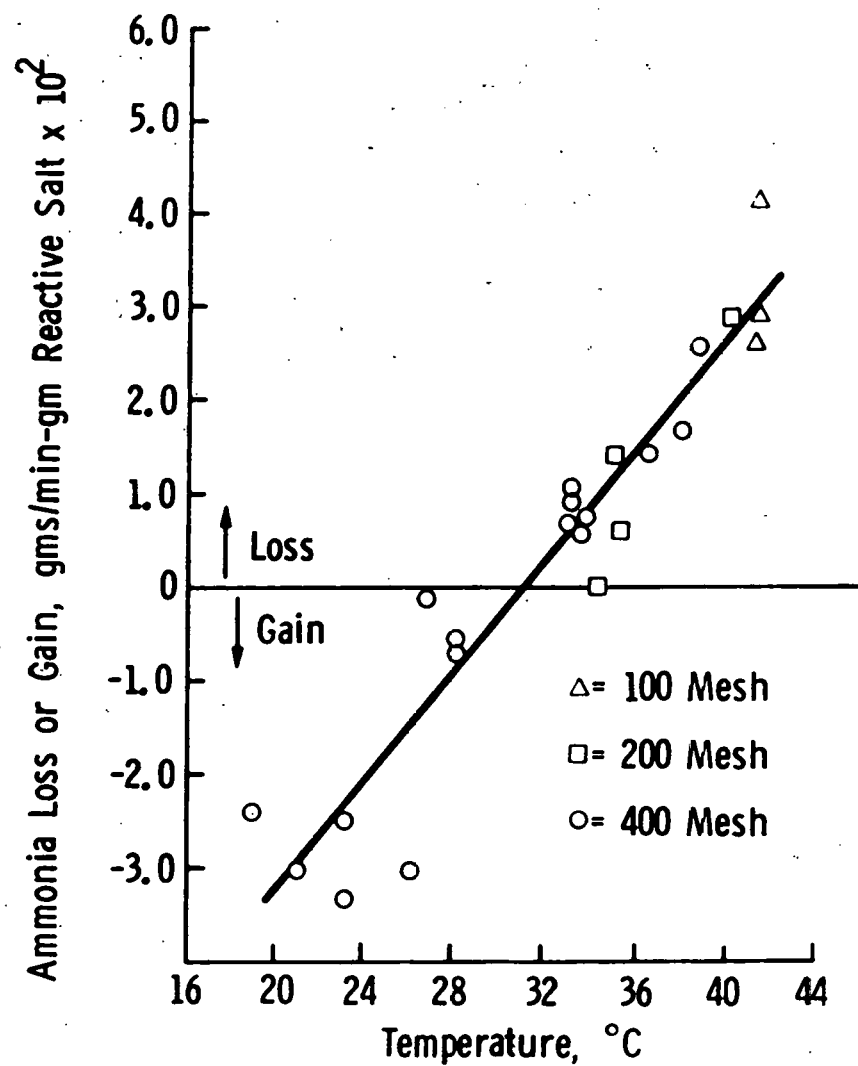
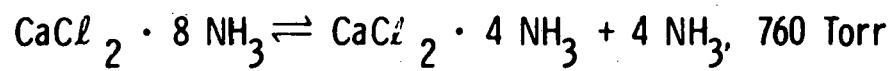

Figure 10. Forward and reverse reaction rate data for the reaction $\text{CaCl}_2 \cdot 8\text{NH}_3 = \text{CaCl}_2 \cdot 4\text{NH}_3 + 4\text{NH}_3$ (Reference 18).

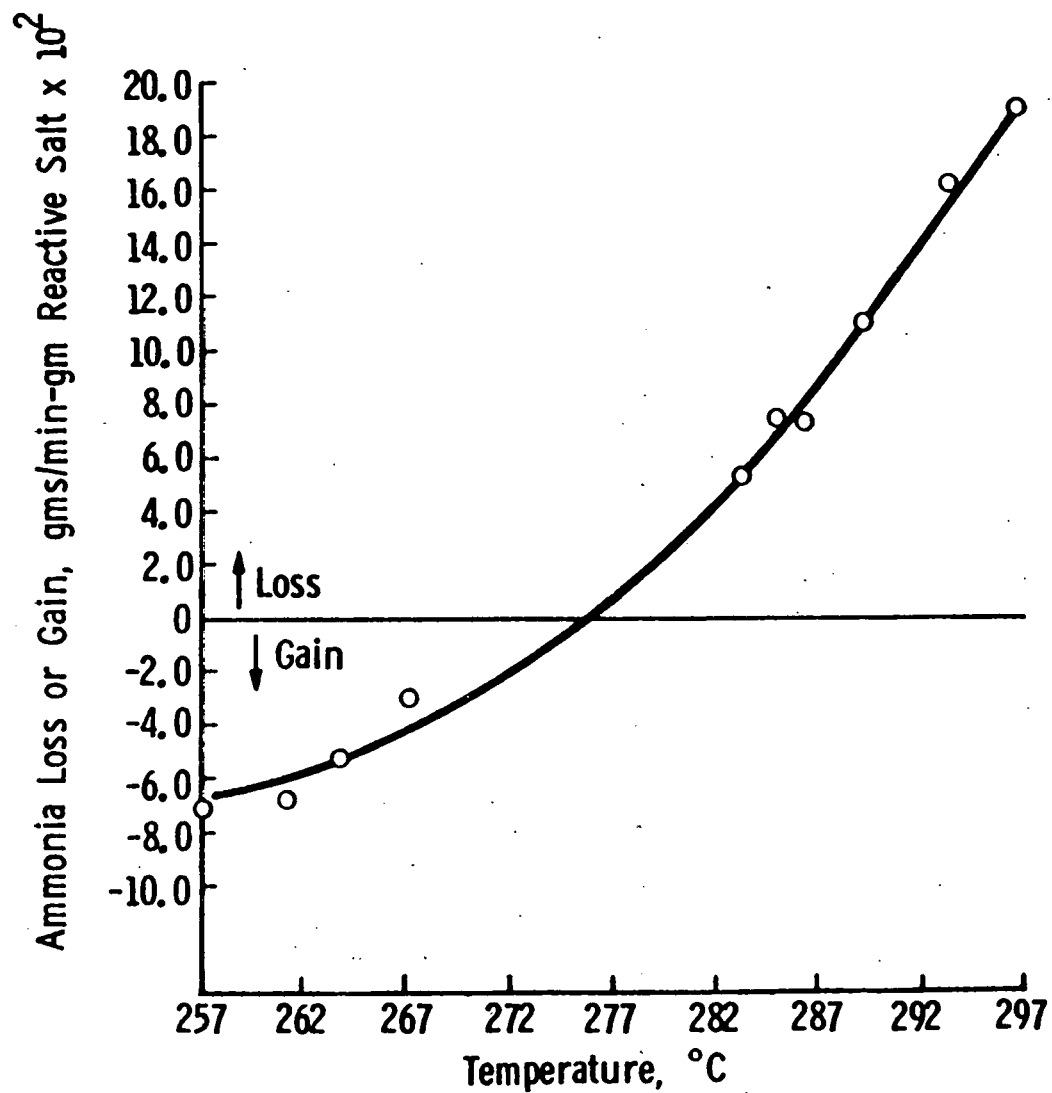
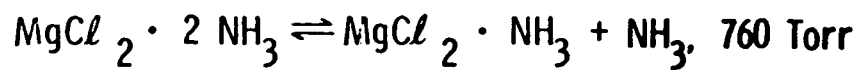
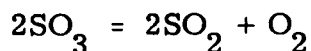

Figure 11. Forward and reverse reaction rate data for the reaction $\text{MgCl}_2 \cdot 2\text{NH}_3 = \text{MgCl}_2 \cdot \text{NH}_3 + \text{NH}_3$ (Reference 18).

magnesium chloride reactions, to be specific. Another potential problem which occurs during the initial ammoniation of a salt bed is sintering, which has been observed on occasion and results in an inert mass. This sintering effect is not well understood, and warrants further attention.

Methanolated Salts--Methanolated salts (salt \cdot n CH₃OH) are possible alternatives to hydrated salts and ammoniated salts. However, there is a paucity of data on methanolated salts. Not only are they ill characterized, but even their existence is not well established. P. Offenhartz and co-workers¹⁹ have initiated a study to identify potential salt systems and thermodynamically characterize them. The ultimate objective of their effort is to develop a methanolated salt heat pump based upon a single-substrate/methanol reaction for use in solar heating/cooling applications. Preliminary results indicate there are several potentially useful salts, viz., MgCl₂, CaBr₂ and FeBr₂; however, it is premature to draw conclusions at this stage.

SO₃ Decomposition--Several investigators have examined the use of the reaction



in storage^{6, 20-22} and transport²³ applications, and system design flow sheets for energy storage applications have been derived. To illustrate the complexity of the SO₂/SO₃ thermochemical system, the process flow diagrams developed by M. L. Bhakta⁶ are given in Figures 6 and 7 for the endothermic and exothermic ends of the system. A flow diagram has also been developed in which the endothermic and exothermic processes are carried out in the same reactor.²⁰

Two materials problems must be addressed before one can commit to the development of an SO₃/SO₂ energy storage system: (1) Are inexpensive and effective catalysts available for the high temperature endothermic reaction, and (2) Are materials of construction which can withstand the corrosive sulfidation/oxidation environment available? These two questions are currently being addressed by Schmidt²⁴ and Bradshaw.²⁵

Even if these materials problems were solved, it is not clear that a concerted development effort will materialize. Preliminary results indicate that the capital cost of an SO₃/SO₂ energy storage system may be excessively high.²² Therefore, strong justification (technical and economic) is needed for the continued development of the system.

Dilution/Concentration--Coupling solar energy to dilution/concentration reactions is not new. Concepts and devices based on the absorption-refrigeration cycle have long been proposed for intermittent solar refrigeration.²⁶ Various refrigerant-absorbent combinations have been studied, including ammonia-water, ammonia-lithium nitrate, water-lithium bromide, Freon 21-tetraethylene, glycoldimethyl ether, and ammonia-sodium thiocyanate.²⁷⁻³¹ However, work to date on the dilution/concentration reactions has generally not explored the potential of incorporating energy storage or heat pumping capabilities.

It is possible to store energy in aqueous solutions of acids (e. g., H₂SO₄) or bases (e. g., NaOH). By adding or distilling water from a solution, one is discharging or storing a quantity of energy equivalent to the enthalpy of dilution. The technical basis for such a process is well understood. Also, heats of solution are well known, and calculational procedures for predicting quantities of input and output energies under various operational conditions (e. g., initial and final concentration) are straightforward.^{32,33} Further, there are no reaction kinetic problems to contend with. Though enthalpies of dilution are not typically as large as enthalpies of decomposition, and one cannot expect enormous energy densities, concentration/dilution schemes offer the advantage of being all-liquid systems in the heat exchanger, thereby facilitating the rates of heat transfer in and out. Operational temperatures will in all probability be restricted to low temperatures because of potential materials corrosion problems.

Methane-Based Reactions--Several methane-based reactions have been proposed for use in energy storage applications; among them are

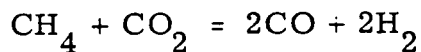
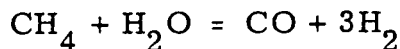

To drive both reactions, high-temperature energy sources (~900 K) are required. Both are catalytically controlled, and the pertinent chemical technology (reaction rates, side reactions, reversibility, catalyst electivity, catalyst availability, etc.) is sufficiently developed to allow one to design and engineer a storage system based upon them. However, a cost-effective use of these reactions in a strict storage application has not been identified; moreover, such an application does not seem imminent. Storage would require the containment of gaseous reactants and products, and gas compression and storage are generally prohibitively expensive. Thus the use of methane-based reactions will most likely be restricted to energy transport applications.³⁴⁻³⁷

Organic Hydrogenation/Dehydrogenation Reactions--It is well known that numerous organic compounds can be catalytically decomposed and recombined according to the generalized reaction

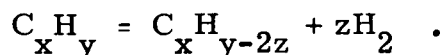

The one reaction often cited is the dehydrogenation of cyclohexane to benzene.^{38, 39} These reactions are catalytic in both the exothermic and endothermic directions, and commercial technology generally exists with regards to catalyst availability, reaction conversion rates, catalyst performance, reaction selectivity, and so on.

It is, however, doubtful that existing technology is really pertinent to storage applications, since the requirements are completely different. Once-through conversion efficiencies, which are important in current industrial applications, are meaningless when one considers storage applications wherein the extent of the side reactions and conversion efficiencies in a cyclic operation are of concern. One must therefore build a new chemical data base which is relevant to thermal energy storage. For this purpose, current industrial technologies do form an excellent base from which to proceed.

The fact that gaseous hydrogen must be compressed and stored is a major problem. The unfavorable economics associated with compressing and storing hydrogen suggest that this class of reactions should not be seriously considered if energy storage is the only application of interest; applications requiring the transport of energy may be feasible. The DOE, Division of Energy Storage Systems, under the technical management of Sandia, is contemplating several studies to address energy transport in chemical heat pipes using the benzene/cyclohexane reaction.^{40, 41}

Inorganic Hydroxides--The alkali and alkaline earth elements form hydroxides and oxides which can theoretically be dehydrated and hydrated, respectively.⁴² Only the $Mg(OH)_2/MgO$ and $Ca(OH)_2/CaO$ systems have been investigated to date,⁴³⁻⁴⁶ and preliminary studies indicate the rates of reaction (hydration and dehydration) to be sufficient for solar heat storage applications. Superheated steam is required to accomplish the hydration of both MgO and CaO . However, MgO was found to be inert in highly superheated steam, a result indicating that an upper temperature limitation to the exothermic reaction exists. The practical implication is that the efficiencies of $Mg(OH)_2/MgO$ -based systems are unacceptably low, since the exothermic (hydration) temperature will necessarily be significantly lower than the endothermic (dehydration) temperature.

CaO does not appear to be inert to highly superheated steam, and current activities are aimed at fully characterizing the $CaO/Ca(OH)_2$ reaction.^{40, 41} Although the optimum application for the $CaO/Ca(OH)_2$

reaction has yet to be defined, the high-temperature storage requirements of solar power generating systems make them leading candidates.

Hydride Decomposition--A large number of metals and alloys react reversibly with hydrogen thus:

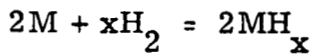

where M is a metal or alloy. Numerous alloys have been studied in detail, for example, Fe-Ti alloys,⁴⁷ Mg-Ni alloys,⁴⁸ and AB₅ compounds,^{49, 50} where A is one or a mixture of rare earths and B is Ni or Co. It is reasonable to assume that one can obtain virtually any desired pressure-temperature relationship by varying the alloy composition. Predictive methods (e. g., correlating thermodynamic properties with average lattice hole size), which are on the verge of surfacing, will allow one to select suitable metal compositions with reasonable confidence.

Experimental evidence to date suggests that hydriding and dehydriding kinetics are rapid. Hysteresis effects have been observed between the absorption and desorption reactions, but the kinetics in either case are sufficiently rapid for most solar storage applications.⁵¹

Hydride reactions are being applied to vehicular propulsion^{52, 53} and to off-peak energy storage for hydrogen-oxygen fuel cell power generation.^{51, 54-55} However, the use of hydrides in thermal energy storage applications imposes different chemical and systems constraints. D. Gruen et al.^{56, 57} have been developing a hydride-based solar heat pump system (referred to as HYCSOS). After selecting the LaNi₅ and mischmetal Ni₅ hydrides, suitable chemical reaction characteristics were proven experimentally, and a subscale system is currently under test. Preliminary results indicate that operational goals will be met; however, the cost of such a system appears to be unacceptably high. Libowitz and Blank⁵⁸ have evaluated hydride-based storage systems relative to sensible and latent heat systems, and also conclude that system economics are unattractive.

In summary, hydride systems, while apparently technically feasible, appear to suffer from poor economics due to costs associated with the chemicals, heat exchanger/reactor components, and hydrogen containment. In addition, questions concerning long term performance and stability are as yet unanswered.

Carbonates--Alkali metal and alkaline earth elements all form stable carbonates which decompose to form one mole of CO₂ gas per mole carbonate. Carbonate compounds are generally quite stable, and high-temperature sources are needed for energy storage applications. Carbonates generally require temperatures in excess of 1100 K.

Numerous investigations have been performed to study the endothermic decomposition reactions,⁵⁹ but the only carbonate for which there is data pertinent to use in an energy storage concept is CaCO_3 .^{60, 61} Thermal cycling did not alter the rate of the endothermic process, which was reasonably rapid in all instances; however, thermal cycling led to a continuous decrease in the exothermic reaction rate.

In summary, the carbonates have not received much attention to date, and clearly the chemical characteristics of such systems will have to be investigated in greater detail. However, as with most gas/solid type reactions, the major problems will probably not be chemical in nature, but will be associated with heat transfer design.

Sulfates--Upon heating, metal sulfates decompose, and the two reactions which must be considered simultaneously are⁶²

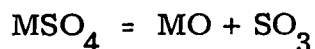

and

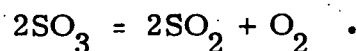

The sulfates are very stable compounds and high temperature sources are required to drive them (generally > 1400 K). A suitable thermal energy source does not seem imminent, and therefore, no research has been directed at metal sulfate-based storage. Given the high-temperature requirements and the corrosive nature of sulfidizing/oxidizing environments, the outlook for sulfate based storage systems is not promising.

Oxide Decomposition--The decomposition of metal oxides has been proposed for energy storage⁶³ applications and the peroxides and superoxides of the alkali metals were suggested as prime candidates. To date, technical feasibility has yet to be demonstrated, and no projects are actively pursuing oxide decomposition concepts. In addition to the normal concerns such as reaction rates, storing gaseous oxygen, and gas/solid heat exchange, the oxides are extremely reactive to water and carbon dioxide, and great care must be taken to exclude them in an operational system.

Other Reactions--Wentworth and Chen,⁶⁴ and Prengle and Sun,⁶⁵ have discussed the use of the reaction

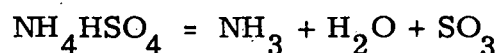

which operates around temperatures of 800 K. The attributes include extremely high energy densities, readily condensable gaseous products which facilitate storage, and liquid-phase heat exchange. Developmental work is

in progress,⁶⁶ and several major problems are identified. Among these are (1) in actual practice the reaction does not proceed as written, and efficient chemical steps must be found to effect the separation; and (2) sulfur/oxygen-containing salts are generally extremely corrosive to materials of construction.

The reaction $N_2 + 3H_2 = 2 NH_3$ has been proposed as an energy transport concept,⁶⁷ but its use solely in energy storage applications is probably limited because of the large costs associated with compressed gas storage and the high operational pressures of this system.

Heat Exchange Modeling and Experiments--Several activities are under way which are concerned with the problem of heat exchanger or reactor design. Springer, et al.⁶⁸ are performing a preliminary analysis of fixed-, moving-, and fluidized-bed reactors. Howerton^{40, 41, 69} and Prenger^{40, 41, 70} are developing a mathematical model for packed-beds and experimentally determining effective conductivities and solid/gas heat transfer coefficients at imbedded surfaces. Wentworth and co-workers⁷¹ are computing solar flux profiles for point focused collectors, and will use this information for reactor design. Offenhartz¹⁹ will be performing lab-scale experiments to obtain engineering design data for packed-bed systems.

C. System Development Activities

System development refers to activities which are "engineering" oriented. The activities range from single component design and evaluation, to total-system design. Very little work is ongoing in this area, because much of the thermochemical technology data base is just now being developed.

Several system development efforts are under way for chemical heat pump storage systems. A number of subscale systems have been designed and fabricated, and are currently being tested to generate operational and performance data. These systems include the sulfuric acid/water storage system,⁷ the HYCSOS system,^{56, 57} and the $CaCl_2 \cdot 6H_2O$ heat pump system.⁷² In addition, L. Greiner¹⁰ is currently testing and designing components integrated into a $MgCl_2 \cdot xH_2O$ chemical heat pump system. It is too early to report conclusive findings from these activities.

The paucity of data and activities reported in this system development section is an accurate reflection of the state-of-the-art of thermochemical systems.

V. Summary and Conclusions

Thermochemical systems possess several unique characteristics when compared to sensible and latent storage systems; these include: (1) high energy densities, (2) ambient temperature storage, (3) long-term storage, (4) transportability, and (5) low energy capacity related costs. The potential advantages must be weighed against the facts that thermochemical systems are furthest from state-of-the-art and, in general, are more complex than sensible or latent systems.

The potential applications of thermochemical reactions include: (1) thermal energy storage systems, (2) energy transport systems, and (3) heat pump and storage systems. The principles of each of these applications were discussed above.

Before the advantages and disadvantages of thermochemical storage systems can be quantified, technology development is required in the following areas:

1. Chemistry - Generally speaking, no such reaction is presently well enough understood to allow its immediate incorporation into a storage system. Consequently, a considerable amount of research and development is required to characterize any potentially useful reaction with respect to such parameters as reaction rates, side reactions, reversibility, cyclability, long-term performance, reproducibility, reliability, and impurity effects. For catalyzed reactions, moreover, additional questions concerning catalyst lifetime, degradation, and poisoning must be addressed.
2. Heat Transfer - Equally important to the thermochemical energy storage system are the chemical reactors and process-stream heat exchangers. Generally speaking, design techniques are available for predicting system performance. What is lacking, however, is information regarding such things as the thermo-physical and transport properties of the various constituents of the chemical system and the effects of catalyst performance, reaction kinetics, long-term cyclic operation, to name a few, on heat transfer. Small-scale experiments are required to verify theoretical predictions before large-scale systems are designed and constructed.
3. Materials - Material compatibility and corrosion problems can be significant, the degree depending upon the temperatures of the storage operation and the chemicals involved. Ambient storage, however, mitigates the material problems to the extent that the corrosive conditions may now be confined to a fairly small

portion of the total system. Unfortunately, the highest temperatures (and therefore the most corrosive environment) are generally found in the most complex and expensive components of the system, viz., the reactor and heat exchangers.

4. Chemical Engineering - Almost all thermochemical reaction cycles for storage or transport applications contain steps which are potentially wasteful of energy and the net result is a much reduced effective energy density. Operational cycles must be optimized, and the recovery and re-use of potential rejected energies are necessities for the development of economically viable thermochemical energy storage and transport systems.
5. Systems Analysis - System studies are required to establish the technical and economic feasibility of a proposed concept, to identify required research, and to establish the relative merits of the proposed system as compared with competing technologies. These studies must continue throughout the development process in order to filter in new information as it becomes available and to ensure that the concepts being developed will be economically viable.

In summary, thermochemical technology is at a very early stage of development, and much is needed in the way of technology development before one can accurately assess the potential of thermochemical techniques, let alone develop thermochemically based concepts to the point of commercialization.

REFERENCES

1. A. W. Searcy, "High-Temperature Reactions" in Survey of Progress in Chemistry, Vol. 1 (Academic Press, Inc., New York) 1963.
2. "Chemical Energy Storage for Solar-Thermal Conversion," Interim Report Number 2, 77-R-558, prepared by Rocket Research Corporation for The National Science Foundation, (under NSF Grant Number AER 75-22176), April 13, 1977.
3. "Reversible Chemical Reactions for Electrical Utility Energy Applications," Rocket Research Corporation report RRC-77-R-559, April 1, 1977.
4. W. E. Wentworth and E. Chen, Solar Energy, **18**, 205 (1976).
5. E. W. Schmidt and P. A. Lowe, "Thermochemical Energy Storage Systems," 11th Intersociety Energy Conversion Engineering Conference, Vol. I, (1976).
6. "Chemical Storage of Thermal Energy Using the $\text{SO}_3\text{-SO}_2\text{-O}_2$ System," M. L. Bhaktar, M. S. Thesis, University of California, Berkeley, 1976.
7. C. Clark, "Sulfuric Acid and Water Integrated Chemical Energy Storage System," Thermal Energy Storage Contractors Meeting, Gatlinburg, Tennessee, September 1977 (proceedings in press).
8. "Chemical Energy Storage for Solar Thermal Conversion/Extended Storage Studies," Rocket Research Company, Redmond, Washington, and Sandia Laboratories, Livermore, California, NSF Grant AER75-22176 and DOE Contract 124217, R. Smith (Rocket Research) and J. Iannucci (Sandia), principal investigators.
9. "Analysis of Advanced Thermal Storage Subsystems for Solar Heating and Cooling," EIC Corporation, Newton, Massachusetts, DOE Division of Solar Heating/Cooling Contract EG-77-C-02-4483 (1977), P. O'D. Offenhartz, principal investigator.

10. L. Greiner, "The Chemical Heat Pump: A Simple Means to Conserve Energy," TES Contractors Meeting, Gatlinburg, Tennessee, September 1977 (proceedings in press).
11. R. W. Carling, "Vapor Pressure Measurements on the Hydrates of Magnesium Chloride," presented at the American Chemical Society Fall Meeting, Chicago, Ill., June 1977.
12. C. A. Hall, M. T. Howerton, and S. Podlaseck, "Thermal Storage by Paired Ammoniated Salts," International Solar Energy Society Meeting, Winnepeg, Canada, Vol. 8, 176 (1976).
13. G. Alefeld, *Bremst-Warme-Kraft* 28, Nr. 1, January (1976).
14. G. Alefeld, *Warme*, 81, 89 (1975).
15. G. Alefeld, *Energie*, 27, 180 (1975).
16. M. Taube, "A Duplex Chemical System for the Storage and Container Transport of Heat for District Heating," presented at a Topical Meeting on Low Temperature Nuclear Heat, Otaniemi, Finland, Aug. 21-24 (1977).
17. "Heat Storage and Energy Transport Using an Absorption/Desorption Salt-Ammonia System," Swiss Federal Institute for Reactor Research, Würenlingen, Federal Republic of Germany.
18. "Development of Ammoniated Salt Thermochemical Energy Storage Systems," (C. Hall, ed.), Martin Marietta Corporation report MCR-76-502, September 1976.
19. P. O' D. Offenhardt, "One Substrate Solvate Energy Carrier System for Storage of Solar Energy," TES Contractors Meeting, Gatlinburg, Tenn., Sept. 1977 (proceedings in press).
20. "Technical and Economic Assessment of Phase Change and Thermochemical Advanced Thermal Energy Storage (TES) Systems," EPRI report EM-256, Project 788-1, Volume 1, December 1976.
21. J. Dayan, A. S. Foss, and S. Lynn "Evaluation of a Chemical Heat Storage System for a Solar Steam Power Plant," 12th IECEC Conference Proceedings, Washington, D. C., August 1977.
22. S. Lynn, "Chemical Storage of Thermal Energy," TES Contractors Meeting, Gatlinburg, Tenn., Sept. 1977 (proceedings in press).
23. T. A. Chubb, *Solar Energy*, 17, 129 (1975).

24. E. W. Schmidt, "Development of a Long-Life High-Temperature Catalyst for the SO₂/SO₃ Energy Storage System," TES Contractors Meeting, Gatlinburg, Tenn., Sept. 1977 (proceedings in press).
25. R. W. Bradshaw, (Sandia Laboratories, Livermore, Ca.) private communication.
26. F. Daniels, Direct Use of the Sun's Energy, (Yale University Press, New Haven, Conn.) 1964.
27. J. C. V. Chinnapa, Solar Energy, 5, 1 (1961).
28. J. C. V. Chinnapa, Solar Energy, 6, 143 (1962).
29. D. A. Williams, R. Chung, G. O. G. Lof, D. A. Fester, and J. A. Duffie, Refringng Eng. 66, 33 (1958).
30. R. K. Swartmen, V. Ha, and C. Swaminathan, Solar Energy, 17, 123 (1975).
31. S. L. Sargent and W. A. Beckman, Solar Energy, 12, 137 (1968).
32. "Sulfuric Acid-Water Energy Storage System," Rocket Research Corporation Report RRC-76-R-530, August 1976.
33. D. D. Huxtable and D. R. Poole, "Thermal Energy Storage by the Sulfuric Acid-Water System," Internat. Solar Energy Society Meeting, Winnepeg, Canada, Vol. 8, p. 178 (1976).
34. H. B. Vakil and P. G. Kosky, "Design Analyses of a Methane Based Chemical Heat Pipe," 11th IECEC Conference Proceedings, 1, 659 (1976).
35. K. Kugeler, H. F. Niessen, M. Roth-Kamat, D. Bocker, B. Ruter and K. A. Theis, Nucl. Eng. and Design, 34, 65 (1975).
36. H. Feddes, R. Harth, and B. Hohlein, Nucl. Eng. and Design, 34, 119 (1975).
37. K. Kugeler, M. Kugeler, H. F. Niessen, and K. H. Hammelmann, Nucl. Eng. and Design, 34, 129 (1975).
38. H. B. Vakil, "Closed Loop Chemical Systems for Energy Storage and Transmission," TES Contractors Information Exchange Meeting, Gatlinburg, Tenn., September 1977 (proceedings in press).

39. A. B. Ritter and G. B. Delancey, "Thermo-Chemical Energy Conversion and Storage," presented at the 2nd Information Meeting for Contractors in the ERDA Hydrogen Energy Program, Arlie, Va., November 1975.
40. T. T. Bramlette and R. W. Mar, "Fiscal Year 1977 Annual Operating Plan for the Thermochemical Energy Storage and Transport Program of the National Thermal Energy Storage Program," Sandia report number SAND77-8226, June 1977.
41. T. T. Bramlette and R. W. Mar, "Fiscal Year 1978 Annual Operating Plan for the Thermochemical Energy Storage and Transport Program," Sandia report number SAND77-8288, in review.
42. G. Ervin, Method of Storing and Releasing Thermal Energy, U. S. Pat. 3 973 552 (June 23, 1975/Aug. 10, 1976).
43. G. Ervin, "Hydration-Dehydration Cycling of $MgO-Mg(OH)_2$ for Application to Solar Heat Storage Systems," Rockwell International, Atomics International Division report AI-ERDA-13178, September 1976.
44. G. Ervin, "Solar Heat Storage Based on Inorganic Chemical Reactions," presented at the NSF/ERDA Workshop on Solar Energy Storage Sub-systems for the Heating and Cooling of Buildings, Charlottesville, Va., April 16-18, 1975.
45. G. Bauerle, D. Chung, G. Ervin, J. Guon, and T. Springer, "Storage of Solar Energy by Inorganic Oxide/Hydroxides, International Solar Energy Society Meeting, Winnepeg, Canada, Vol. 8, pp. 192 (1976).
46. G. Ervin, D. Chung, and T. Springer, "A Study of the Use of Inorganic Oxides for Solar Energy Storage for Heating and Cooling of Buildings," Rockwell International, Atomics International Division report AI-75-63, October 1975. (NSF report NSF/RANN/SE/G1-44126/FR/75/2).
47. J. J. Reilley and R. H. Wiswall, *Inorg. Chem.*, 13, 218 (1974).
48. J. J. Reilley and R. H. Wiswall, *Inorg. Chem.*, 7, 2254 (1968).
49. J. H. N. van Vucht, F. A. Kuijpers, and H. C. A. M. Brunin, *Phillips Res. Rep.* 25, 133 (1970).
50. F. A. Kuijpers and H. H. von Mal, *J. Less Common Metals*, 23, 395 (1971).

51. K. C. Hoffman, J. J. Reilley, F. J. Salzano, C. H. Waide, R. H. Wiswall, and W. E. Winsche, *Int'l. J. Hydrogen Energy*, 1, 133 (1976).
52. C. E. Lundin, "The Use of LaNi_5 as a Hydrogen Source for Fueling a Non-Polluting, Internal Combustion Engine," *Proc. 10th Rare Earth Research Conference*, Arizona State University, May 1973.
53. C. E. Lundin and F. E. Lynch, "Development of Lightweight Hydrides for Automotive Power Application," Annual report, Denver Research Institute contract with Daimler-Benz, Stuttgart, Germany, December 1975.
54. G. Strickland, paper 54-9, *THEME Conference Proceedings*, Miami Beach, Fl., March 1974.
55. F. J. Salzano, ed. *Hydrogen Storage and Production in Utility Systems*, BNL-19249, July 1974.
56. D. M. Gruen, R. L. McBeth, M. Mendelsohn, J. M. Nixon, F. Schreiner, and I. Sheft, "HYCSOS: A Solar Heating, Cooling and Energy Conversion System Based on Metal Hydrides," *Eleventh IECEC Conference*, Vol. I, pp. 681 (1976).
57. D. M. Gruen, I. Sheft, G. Lamich and M. Mendelsohn, "HYCSOS: A Chemical Heat Pump and Energy Conversion System Based on Metal Hydrides," *Argonne National Laboratory report number ANL-77-39*, June 1977.
58. G. G. Libowitz and Z. Blank, "An Evaluation of the Use of Metal Hydrides for Solar Thermal Energy Storage," *Eleventh IECEC Conference*, Vol. I, pp. 673 (1976).
59. eg. see K. H. Stern and E. L. Weise, "High Temperature Properties and Decomposition of Inorganic Salts: Part 2, Carbonates," *NSRDS-NBS30*, November 1969.
60. R. Barker, *J. Appl. Chem. Biotechnol.* 23, 733 (1973).
61. R. Barker, *J. Appl. Chem. Biotechnol.* 24, 221 (1974).
62. K. H. Stern and E. L. Weise, "High-Temperature Properties and Decomposition of Inorganic Salts: Part 1. Sulfates," *National Standard Reference Data Series--National Bureau of Standards 7 (NSRDS-NBS7)*, October 1960.

63. J. A. Simmons, "Reversible Oxidation of Metal Oxides for Thermal Energy Storage," International Solar Energy Society Conference, Vol. 8, pp. 219, K. W. Boer, ed., Aug. 15-20, 1970, Winnepeg, Canada.
64. W. E. Wentworth and E. Chen, *Solar Energy*, 18, 205 (1976).
65. H. W. Prengle, Jr., and C. H. Sun, *Solar Energy* 18, 501 (1976).
66. W. E. Wentworth, "The Development of Operational Chemical Cycles for the Storage of Thermal Energy," TES Contractors Information Exchange Meeting, Gatlinburg, Tenn., September 1977 (proceedings in press).
67. P. O. Carden, "Coradiation Using the Reversible Ammonia Reaction," International Solar Energy Society Conference, Los Angeles, 1975.
68. "Solar Energy Storage by Reversible Chemical Processes," Rockwell International Division, Atomics International Division, Canoga Park, Ca., Sandia Laboratories contract 18-0497 (1977), T. Springer, project manager.
69. "Development of Ammoniated Salts Thermochemical Energy Storage Systems," Martin Marietta Aerospace, Denver, Colorado, DOE Contract EY-76-6-03-1229 (1977), T. Howerton, principal investigator.
70. "Heat Transfer Investigation," Martin Marietta Aerospace and Colorado State University, Denver, Colorado, Sandia Contract 87-8253 (1977), C. Prenger, principal investigator.
71. "Development of Operational Chemical Cycles for the Storage of Energy," University of Houston, Houston, Texas, DOE Division of Solar Energy Contract EG-77-C-043974 (1977), W. E. Wentworth, principal investigator.
72. Private communication, G. Wettermark, Division of Physical Chemistry, Royal Institute of Technology, S-10044, Stockholm 70, Sweden.

UNLIMITED RELEASE

INITIAL DISTRIBUTION:

A. Narath, 5000; Attn: J. H. Scott, 5700
G. E. Brandvold, 5710
J. F. Banks, 5711
J. A. Leonard, 5712
B. W. Marshall, 5713
R. P. Stromberg, 5714
R. H. Braasch, 5715
D. G. Schueler, 5719
H. M. Stoller, 5730
R. K. Traeger, 5731
S. G. Varnado, 5735
V. L. Dugan, 5740
R. S. Claassen, 5800; Attn: R. G. Kepler, 5810
M. J. Davis, 5830
H. J. Saxton, 5840
R. L. Schwoebel, 5820
T. B. Cook, Jr., 8000; Attn: C. H. DeSelm, 8200
W. C. Scrivner, 8400
A. N. Blackwell, 8010
L. Gutierrez, 8100
R. C. Wayne, 8130
W. G. Wilson, 8131
T. T. Bramlette, 8131 (25)
A. C. Skinrood, 8132
L. G. Radosevich, 8132
G. W. Anderson, 8140
B. F. Murphey, 8300
D. M. Schuster, 8310
D. R. Adolphson, 8312
R. W. Mar, 8313 (25)
W. R. Hoover, 8314
L. A. West, 8315
T. S. Gold, 8320
P. J. Eicker, 8326
J. L. Wirth, 8340
Publications and Public Information Division, 8265, for TIC (2)
F. J. Cupps, 8265/Technical Library Processes Division, 3141
Technical Library Processes Division, 3141 (2)
Library and Security Classification Division, 8266-2 (3)

THIS PAGE
WAS INTENTIONALLY
LEFT BLANK

Session 2

TECHNICAL ISSUES

Paper 2-1

**Thermal Storage Requirements Criteria for
Solar Power Plants Interfacing with
Utility Systems**

**W.C. Melton
The Aerospace Corporation
P.O. Box 92957
Los Angeles, CA 90009**

15 February 1978

I. INTRODUCTION

Solar thermal electric power plants (STEPS) are different from conventional power plants in many ways. However, in the context of this discussion, the single most important distinction is that the solar energy which feeds a STEP is (1) periodic in its availability to the STEP, and (2) not storable or capable of stockpiling before its use, as are coal and oil. The natural response to that is to design a thermal storage system as an integral part of the STEP. The thermal storage system then preserves the received solar energy after its conversion to heat but before its conversion to electric energy at some later time when it is more valuable.

In the past four years, since Aerospace first completed its mission analysis for solar thermal electric plants, there has been a continuing discussion about the value of thermal storage for a STEP. Of course, the value of the storage must relate to the way it is used. The way it is used must in turn relate to the mode of operation of the STEP in the presence of (a generally larger amount of) conventional generation.

The purpose of this paper is to discuss various aspects of the design and use of storage and its value. A logical case will be developed which points toward an increase in storage over and above that which has so far been advocated -- but without the concomitant increase in heliostat field size (for a specified turbo-generator nameplate rating).

II. CONCEPT OF STEP VALUE

In considering the acquisition of a STEP, some value must be associated with that acquisition in order to determine if the cost of the STEP is a warranted expenditure. The value has two basic parts: (1) operational and (2) capital.

The operational part of the STEP value will be the difference in the cost of meeting the same customer demand with and without the STEP contributing to the production of electricity. For the case without the STEP, the optimum mix of conventional generation will, in general, be different from the optimum mix which includes the STEP. That is, operational value of the STEP is the difference in operating cost of two distinct optimum mixes, each operated in an optimum (minimum cost) manner. Most of the operational value of a STEP will be due to fuel savings, but O&M differentials will also contribute to the value.

The capital part of the STEP value will be due to a decrease in capital expenditures which would otherwise obtain if the STEP is not acquired. That is, it is the capital cost for new generating units in the event that a STEP is not acquired minus the cost for (just) the conventional generation if a STEP is acquired. This cost will reflect the change in the optimum mix (more peakers and fewer intermediates might be required, for example) in the presence of the STEP, as well as a decrease in the conventional capacity (MW) required to satisfy the stipulated reserve margin criteria.

After suitable financial analysis and arithmetical adjustments to convert capital costs and operational costs into the same kind of dollars, the two elements can be summed to obtain a total value of the STEP.

The relationship of the thermal storage subsystem to the overall design and operation of a STEP to maximize its total value (and thereby justify its cost) is the subject of this paper.

III. STEP OPERATIONAL VALUE

A system of (all) conventional generating units (i.e., not including a STEP) is operated so as to minimize the cost of supplying the electricity required to meet the customer demand. Fixed costs associated with the capital expenditures for installing the units are not considered in the operation of the system -- the fixed costs are what they are regardless of how the system is operated. In general, as the demand rises, the more inefficient units are started up (committed) in the same order as their efficiencies decrease and as the demand subsequently falls, they are shut down in reverse order. For a given complement of committed units, each unit is individually loaded such that the total cost of supplying the electricity demanded by the customers is minimized.

With some utilities, the unit commitment and dispatching are done to minimize atmospheric pollution. The principals of optimization are basically the same as with minimizing the dollar cost. To avoid circumlocution, the problem is discussed below in terms of dollar cost minimization; no generality is lost.

For a system of generating units which includes a STEP, the problem is more complicated but the objective must still be the same: to minimize the cost of supplying the electricity required to meet the customer demand. Here again, fixed costs are immaterial in the minimization process.

The STEP operating cost (not value) is essentially independent of how much electricity it supplies, or when it is supplied, or any other operational consideration for that matter. It is generally not optimal to operate the STEP to supply as much electricity as possible regardless of when the electricity is supplied, because the value of the supplied electricity will generally vary with the time of day.

The addition of a thermal storage system permits the postponement of the use of the solar energy to a time when it will be more valuable. However, the use at a later time will be at a somewhat reduced efficiency. Therefore, as the day unfolds, the STEP operator will be faced with a continuing decision process: whether or not to spend the thermal energy now or later (when the electricity is more valuable but more energy is lost because of a lower efficiency).

The value of the electricity output by the STEP depends on what it would have cost to produce that same electricity with conventional units had the STEP output been zero. That value depends on the marginal cost of production. Define the incremental cost of production to be $\delta\psi$, mills/kWh. $\delta\psi$ depends on the level of customer demand which in turn depends on the time of day, day of the week, week of the year, and so on. That is, $\delta\psi$ is dependent on time. If the output of the STEP is $E(t)$, the STEP should be operated so as to maximize Φ where

$$\Phi = \int_0^{\infty} E(\tau) \delta\psi(\tau) d\tau$$

The lower limit on the integration begins at the time of STEP initial operation. At some later time, t_{now} , what has happened in the past cannot be changed, so the quantity to be maximized must be

$$\Phi = \int_{t_{\text{now}}}^{\infty} E(\tau) \delta\psi(\tau) d\tau$$

The output $E(\tau)$ must be scheduled so as to maximize Φ without violating limits on storage energy capacity, storage charging and discharging rates, turbogenerator output level, and so on.

The optimal scheduling of $E(\tau)$ requires knowledge of future values of $\delta\psi(\tau)$ which implies knowledge of the future customer demand. It also requires knowledge of future insolation. The prediction accuracy will decrease as the distance into the future increases and there comes a point where it is inappropriate to continue the integral. Then, the truncated integral to be maximized is

$$\Phi = \int_{t_{\text{now}}}^{t_{\text{now}} + \Delta t} E(\tau) \delta\psi(\tau) d\tau$$

Now, there should be a boundary condition on the energy in storage at $\tau = t_{\text{now}} + \Delta t$. In theory, the optimal schedule for charging and discharging storage so as to maximize Φ should be continually redetermined as t_{now} advances through time. Actually, the optimization process will probably only need be repeated on an hourly basis. For planning studies a discrete hourly calculation is appropriate in which case

$$\Phi = \sum_{j=1}^N E(i+j-1) \delta\psi(i+j-1), \text{ Storage Energy (N) = Stipulated Value.}$$

Where the i^{th} hour is the current hour. It would seem appropriate to set $N=24$, but studies of insolation predictability need to be undertaken to determine that. It appears that demand can be predicted with more than enough accuracy relative to the insolation prediction accuracy.

When the STEP is operated to maximize Φ , the overall cost of production for the entire system will be minimized. Note that this criterion may not maximize the amount of electricity output by the STEP, but it will maximize the operational value of the electricity output by the STEP. No consideration is given to reserve margin or "capacity credit" in this optimization, for those considerations relate to emergency operations. Minimizing the cost of production is a standard operating procedure which is generally abandoned in an emergency. The capital value of a STEP is closely related to emergency operations as described in the next section.

Note that some amount of storage may be allocated to standard operations so as to maximize the operational value of the STEP. There will be a concomitant amount of heliostat installation (for a given turbogeneration nameplate rating) corresponding to the operational storage. Past Aerospace studies which have crudely maximized Φ as defined above, have arrived at six hours of operational storage as optimal.

IV. STEP CAPITAL VALUE

The installation of a STEP will (1) decrease the amount of conventional capacity that would have otherwise been installed, and (2) modify the mix (ratio of baseload to intermediate to peaking units; ratio of nuclear to coal to oil to etc. units) that will be installed. The consequent change in capital expenditures for conventional capacity is the capital value of the STEP.

The determination of the allowable decrease in conventional capacity due to the installation of a STEP requires the calculation of the system reserve margin. There are a variety of margin criteria used in the industry but the most widely used criterion is based on the Loss-of-Load Probability (LOLP).

If for some short period of time, say one hour, the demand will be at a given level (MW), LOLP is the probability that there will not be enough operable units to meet that demand. The LOLP calculation does not reveal probabilistic information on the duration of a capacity short fall, nor does it provide information on the amount of the short fall. Such information is of importance to a utility, but is generally too complex for use in generation planning. LOLP is regarded as a reliability "index" for use in planning generation installation and maintenance schedules. It is a calculated number which responds to important basic parameters of a generating system: the number of units in the system and their individual capacities and reliabilities.

For LOLP calculations, the reliability of a generating unit is described by its forced outage rate, which is simply the fraction of time the unit was not available because it was inoperable (not including the time it was unavailable because of scheduled preventive maintenance). In some very large units, it is possible for the unit to fail partially. One of several boilers may go out, for example. For such units, the mutually exclusive states are individually associated with a probability of occurrence and the capacity corresponding to that occurrence. This more complex description of outage probabilities can be readily accommodated in a typical LOLP algorithm.

To calculate LOLP, every possible combination of units in a forced outage condition is identified and the corresponding probability of that occurrence is calculated. The resulting probabilities are ordered in terms of ascending magnitude of capacity in a forced outage condition, and the running sum of the probabilities is calculated from the bottom (zero capacity out) up. This running sum as a function of the outage capacity is the cumulative distribution function for system outage which can then be used to calculate LOLP. The actual calculation of the distribution function is more efficiently organized than that described above, but it is the same calculation in principle and produces exactly the same results.

If the LOLP calculation is repeated for every hour of the year and the results for each hour are all summed together, the result is the probable number of outage "events" per year. The probable number of outage events per year can also be calculated using only that particular hour of each day corresponding to peak demand. If only daily peaks are used, the calculated number of events per year will be smaller because 23 hours of each day are ignored. Some utilities calculate the annual LOLP

using only the daily peaks. Because of the different bases for the calculation, and because of different levels of emphasis on the importance of LOLP, there is no generally agreed upon criterion for an acceptable level of LOLP. It should be noted in this connection that the units of LOLP (and the quoted LOLP criterion) are often given to be hours per year (usually when the quoted annual LOLP was calculated using every hour of the year) and just as often said to be in days per year (usually when the calculation is based on daily peaks, but sometimes when every hour of the year is used and the results are divided by 24). There can get to be no end of confusion and debate about this, and it appears to be best to quote the number in terms of events per year while simultaneously indicating the basis for the calculation.

For a system using all conventional generation, there is some merit to basing the calculation on daily peaks only, because the computational load is significantly reduced. This mode of calculation is often accurate enough because the peak hours tend to dominate LOLP and the general effect of changes in unit schedules, capacities and reliabilities is adequately reflected in the results. The LOLP criterion quoted for the system should reflect that the calculation is based only on daily peaks, of course. However, the availability of an optimally designed STEP (operated in a maximum-value mode) will vary considerably through the day. The output will generally go to zero in the late evening-early morning hours. This strong hourly variation has suggested that LOLP be calculated on an hourly basis. Heretofore, the calculation of LOLP with a STEP in the generating mix has been based on the STEP availability (output) corresponding to a standard maximum-value operating procedure.

There are two basic ways in which the LOLP has been calculated for a utility using a STEP in conjunction with conventional generation. Both approaches require hourly calculations and the synthesis of the STEP hourly power output based on as much historical insolation data as can be obtained (either directly or indirectly through correlation means). The two approaches are:

- (1) Subtract the synthesized STEP output from the demand, and calculate LOLP using the outage rate data for the conventional units meeting the residual demand.
- (2) Synthesize forced outage rates (dominated by insolation outage) for the STEP using the hourly STEP power output data, and then calculate LOLP using the outage rate data for both the STEP and conventional units meeting the total demand.

Done correctly, the two approaches will give essentially the same results, but the first requires averaging to remove the effects of arbitrary phasing between society (as reflected in demand time histories) and STEP capability which has no dependence on the day of the week. Note in the first approach that the hour of the day corresponding to the peak residual cannot be identified a priori (unless the STEP capacity is small relative to the peak demand), suggesting that it is most appropriate to calculate LOLP on an hourly basis when evaluating a large STEP penetration. In addition to the averaging problem, the first approach requires treating supply as a

negative demand which confuses the bookkeeping and implementation of other demand-dependent criteria. It is more straightforward and computationally efficient to use the second approach.

When the LOLP is calculated in this way for a small penetration of STEPs (< 15%) into the mix, the improvement in the LOLP due to the addition of a STEP operating with a capacity factor CF is approximately equal to that which would be obtained with a conventional unit which has a nameplate rating of CF times the STEP nameplate rating. That is, the STEP "capacity credit" \approx CF (in percent).

An optimally designed STEP (according to earlier analyses, which are generally being confirmed by current analyses) will operate with a capacity factor of around 40% in the Southwest. This is about the same as is obtained with a fossil-fueled cycling unit in a typical mix. The "capacity credit" for the STEP is also about 40%, depending on the capacities and numbers of STEPs relative to the capacities and number of hypothetical conventional units being displaced.

If the LOLP improvement for the fossil plant were computed on the same basis, i.e., with its availability probability figured according to its output when economically dispatched, it would show the same results as computed in the above manner for a STEP.

This immediately suggests that a means should be found to justify the calculation of the STEP contribution to LOLP in the same way as ordinarily done for a conventional unit. If some amount of thermal storage can be added (without additional heliostats) to the system and that amount of storage is always topped off and available for emergencies when there has been a forced outage of other units, the LOLP can be calculated on the same basis as a conventional unit. That is, the STEP forced outage rate will be (1) essentially independent of time (thermal energy is always available from the emergency storage), and (2) small (basically reflecting the same mishaps and breakage as experienced with a conventional thermal unit).

It only remains to determine what amount of emergency storage is required to justify this approach. Six hours (additional)? Twelve hours? The answer will depend on (1) the duration of the subject utilities' daily high-demand period and its magnitude relative to the overall diurnal profiles, and (2) the time-to-repair statistics for that utilities' forced outages. Further analysis is required in this area and seems justified based on the following simplified cost and value analysis.

The STEP cost analyses reported by DoE contractors in the summer of 1977 have been merged by Aerospace to form cost estimating relationships for use in various planning analyses. The CER for thermal storage is

$$\begin{aligned} \text{Avg cost for first N units, 1977 \$/MWh} &= \\ &= 789,000 \times (\text{MWh/unit})^{-.462} \times N^{-.074} \end{aligned}$$

Accepting for this analysis that the optimum amount of storage for facilitating a max-value dispatch of the STEP is 6 hours x 100 MW = 600 MWh for a 100 MW plant (or 8.6 hours at a storage-driven output level of 70 MW) and that there will be 10 of these units purchased against a common spec:

$$\text{Avg cost per unit} = \$20.8 \times 10^6$$

If six hours of storage (at 70 MW) is added for emergency use:

$$\text{Avg cost per unit} = \$27.7 \times 10^6$$

The differential for adding six hours of schedulable operating capacity at 70 MW is therefore $\$6.9 \times 10^6$. It is now asserted that the STEP capacity credit is 70 MW because (1) its capacity is schedulable, and (2) its forced outage rate will be essentially the same as a conventional 70 MW intermediate unit. The capacity credit attributed to the STEP without this extra storage would be about $.40 \times 100 \text{ MW} = 40 \text{ MW}$. Thus, 30 MW of additional capacity can be obtained for $\$6.9 \times 10^6$ or $\$230/\text{kW}$. This is a very cost-effective number because the value of intermediate fossil capacity runs around $\$400/\text{kW}$. Furthermore, the cost for the STEP will drop from around $\$6250/\text{credited kW}$ to $\$3670/\text{credited kW}$, a 41% decrease.

V. SUMMARY AND CONCLUSIONS

For planning analyses, the operational value of a STEP must be calculated in a manner consistent with the way a STEP will actually be operated. Like any other generating unit under ordinary non-emergency conditions, a STEP will be operated so as to minimize the total utility cost of production. Because the STEP heat rate is zero, this will correspond to maximizing the value of the STEP output as defined by the incremental cost rate for the economically dispatched conventional units. The STEP storage capacity optimized on this basis is that part of storage associated with standard non-emergency operations.

It is then suggested that some additional amount of storage should be added (without a concomitant heliostat addition) to be held in reserve for emergencies so that full capacity credit can be attributed to the STEP.

In planning the installation of new capacity, LOLP or some other similar criterion is used to determine when and how much capacity must be added. The objective is to plan the new installations (and maintenance scheduling) so as to minimize the possibility of a capacity shortfall in emergency situations due to forced outage. Past studies of STEP operations have based the LOLP contribution of a STEP on its statistical availability when operated in a non-emergency maximum-value mode. Insolation outage dominates the statistical performance in this situation. It is suggested in this paper that it might be very cost effective to add some amount of storage which is always full and kept in reserve to meet generation emergencies. If enough storage is added (say six hours) to satisfy power pool contracts and other yet to be invented criteria based on time-to-repair statistics for conventional generation, full capacity credit should be attributable to the STEP. Further study is required.

VI. ACKNOWLEDGEMENTS

The concepts and considerations in this paper were independently derived by the writer, but also appear in the following report in somewhat different form. The

concept of emergency storage is mentioned there, but dismissed immediately as being not cost effective.

"A Methodology for Solar Thermal Plant Evaluation" prepared by John T. Day, Program Manager, Westinghouse Electric Corporation, Draft Version, dated March 1977, (for EPRI).

The discussion of LOLP calculations was modified slightly and lifted from a subsection of the following paper to be published in the proceedings of the DoE Wind Energy Workshop held in Washington, DC, September 1977:

"Loss of Load Probability and Capacity Credit Calculations for WECS" by Walter C. Melton, The Aerospace Corporation.

THIS PAGE
WAS INTENTIONALLY
LEFT BLANK

Paper 2-2

OPTIMAL DISPATCH OF STORAGE FOR SOLAR PLANTS
IN A CONVENTIONAL ELECTRIC GRID

J. B. Woodard
Systems Studies Division III 8326
Sandia Laboratories, Livermore

February 1978

Sandia Laboratories, as technical manager of the advanced central receiver program, is evaluating technologies for solar thermal electric power plants. Solar plants may be designed and evaluated as stand-alone units using plant energy production cost as the figure of merit. But, because insolation and demand for electric power are imperfectly correlated in time, storage unit design and dispatch play key roles in determining the value of a solar electric plant to a conventional electric grid. To find out how grid considerations modify the evaluation and design of solar plants, a storage dispatch algorithm must be developed which considers the load and other plants in the grid. This paper outlines the requirements for such a dispatch algorithm.

The value of a solar plant is the difference of the present value of the conventional utility-wide generation costs without the solar plant and the present value of the conventional utility-wide generation costs with the solar plant. Conventional utility-wide generation costs include fixed costs (considering reserve capacity) and variable costs (considering spinning reserve) for all non-solar plants in the network. In each case, the conventional or non-solar plants are optimized economically with the same reliability constraint.

The value of a solar plant is influenced by system spinning reserve requirements, system reserve capacity requirements, and the timing of solar plant generation, as well as the total annual electrical energy produced. Power produced by the solar plant is more valuable during periods of high demand. A base load solar plant may not be twice as valuable as a plant with a 50% capacity factor but which can generate during the system peaks. Proper design and operation of the solar plant can enhance its ability to replace high-cost fuel.

Reserve capacity is the difference of the net system generating capability and the system maximum load requirements. Adding solar plants to the grid may require additional reserve

capacity to maintain system reliability. Solar plant capacity credit may be enhanced by proper solar plant design and operation.

Spinning reserve is the difference of the capability of generating units immediately available and system load. Hydro plants with less than two hours of operation remaining are not counted by Southern California Edison in their calculation of spinning reserve. It remains to be determined how solar plants will be counted in the calculation of spinning reserve. Counting a solar plant only if there is energy in storage will decrease the value of a solar plant unless it is properly designed and operated.

To illustrate the need to understand grid requirements, consider sizing the electric power generation capability of a storage system in a solar plant with a water/steam receiver and a dual admission turbine. The storage system is a two-stage unit with a rock/oil-packed bed, main storage loop and a molten salt, separate-tank superheat loop. Higher generation capability from storage requires greater pressure in the steam generator. But higher boiling pressures mean smaller temperature differences in the oil and, therefore, more rock, oil and tanks are required. This is illustrated on the T-H diagram in Figure 1. Curve 1 shows the path taken by the receiver steam when changing thermal storage. Curve 2 is the turbine expansion line. Curves 3 and 4 are the paths taken by the storage steam during discharge at 500 psia and 1000 psia. Clearly, the 1000 psia curve intersects the turbine expansion line nearer the turbine inlet and provides more electric power. However, the temperature difference is smaller for the 1000 psia curve requiring more oil, rock and tanks.

The relative cost of the storage unit as a function of its relative generation capability is shown in Figure 2. From this curve it appears possible to increase the storage generation capability above 70% at a modest increase in cost. The benefits of

increased generation capability are the ability to displace more high-cost fuel, increased capacity credit and larger spinning reserve credit. Quantification of these benefits requires the development of a dispatch algorithm and grid simulation which can compute the value of a solar plant. Without quantification of the value of a solar plant, it is impossible to say if the increase in cost is justified.

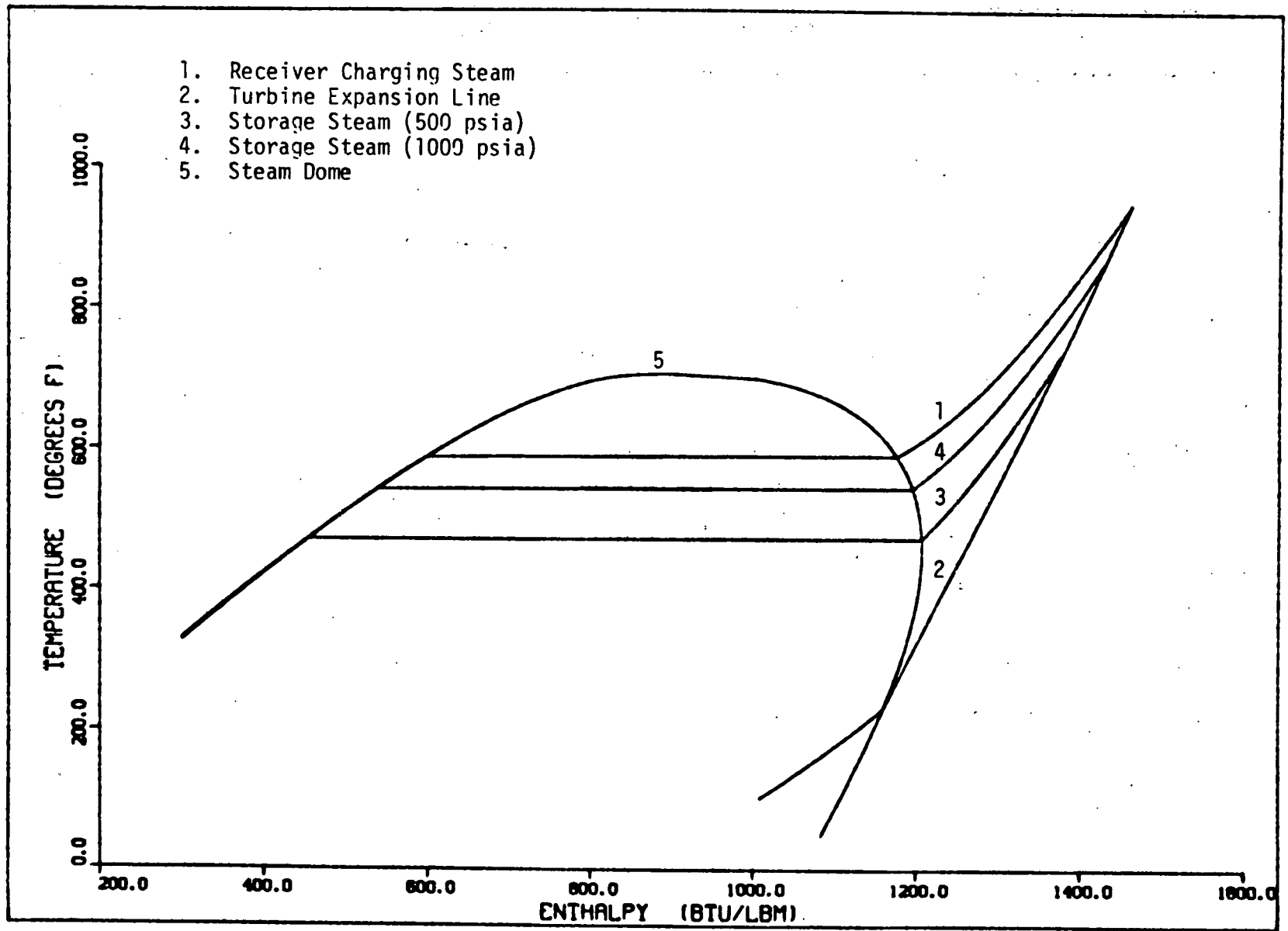

Figure 1. T-H Diagram

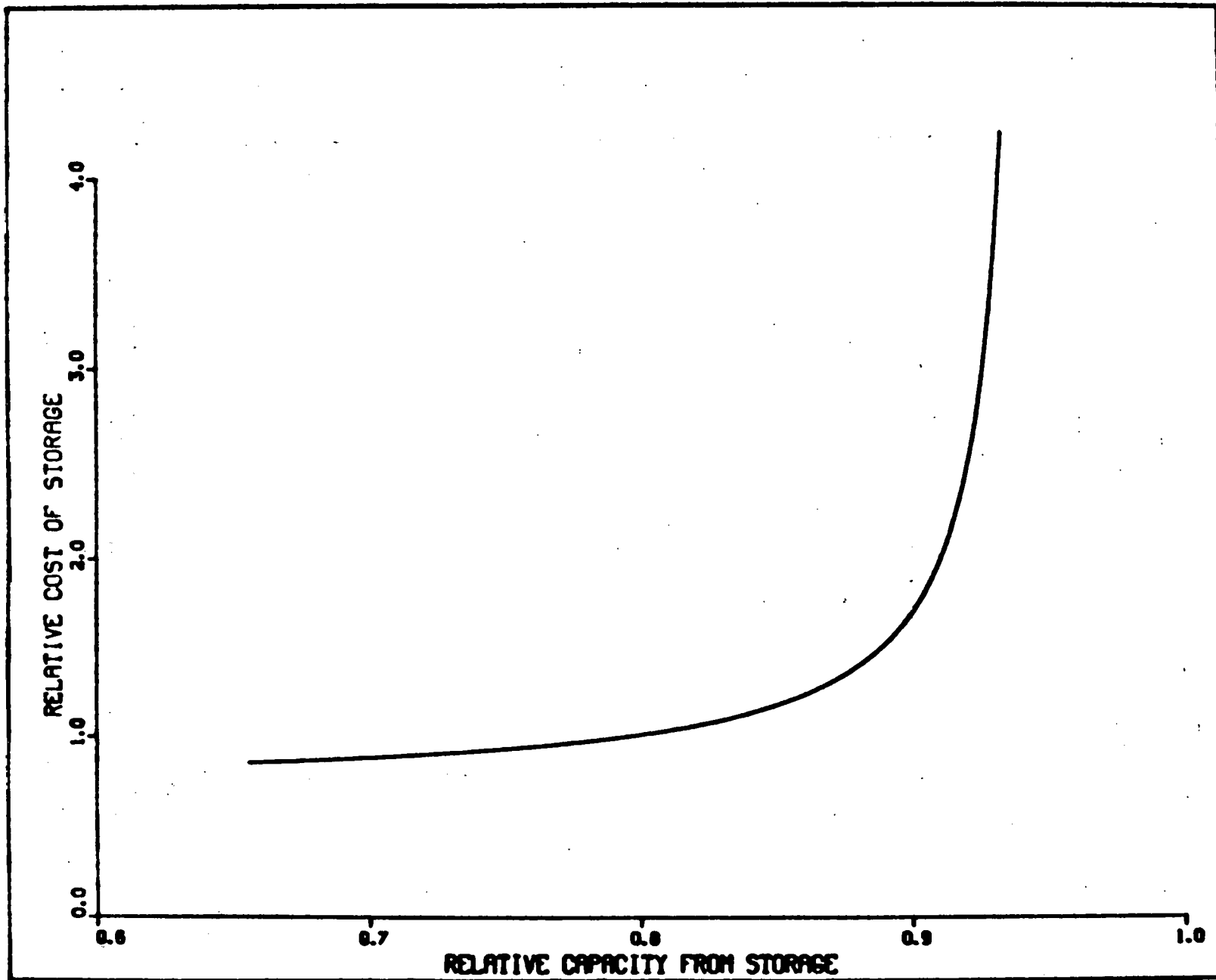

Figure 2. Relative Cost vs. Relative Capacity

OPTIMAL DISPATCH OF STORAGE FOR SOLAR
PLANTS IN A CONVENTIONAL ELECTRIC GRID

THE QUESTION

HOW WILL ELECTRIC GRID CONSIDERATIONS MODIFY A SOLAR
PLANT DESIGNED TO MINIMIZE PLANT POWER PRODUCTION COSTS
(MILLS/KWH_E).

DESIGN PARAMETERS OF INTEREST

- FIELD AND RECEIVER SIZE
- STORAGE CHARGE RATE
- STORAGE CAPACITY
- GENERATING CAPACITY AND EFFICIENCY FROM STORAGE

VALUE OF A SOLAR PLANT

DIFFERENCE OF

PRESENT VALUE OF CONVENTIONAL UTILITY-WIDE
GENERATION COSTS WITHOUT THE SOLAR PLANT

AND

PRESENT VALUE OF CONVENTIONAL UTILITY-WIDE
GENERATION COSTS WITH THE SOLAR PLANT.

CONVENTIONAL UTILITY-WIDE GENERATION COSTS

FIXED (INCLUDING RESERVE CAPACITY)

VARIABLE (INCLUDING SPINNING RESERVE)

FOR ALL NON-SOLAR PLANTS OPTIMIZED ECONOMICALLY WITH THE
SAME RELIABILITY CONSTRAINTS

ECONOMIC DISPATCH
OF SOLAR PLANTS

POWER PRODUCED DURING PERIODS OF HIGH DEMAND IS MORE
VALUABLE TO THE GRID.

RESERVE CAPACITY

DIFFERENCE OF

NET SYSTEM GENERATING CAPABILITY

AND

SYSTEM MAXIMUM LOAD REQUIREMENTS

INCLUDING SOLAR PLANTS IN AN ELECTRIC GRID MAY REQUIRE
ADDITIONAL RESERVE CAPACITY TO MAINTAIN SYSTEM RELIABILITY.

SPINNING RESERVE

DIFFERENCE OF

TOTAL CAPACITY OF GENERATING UNITS IMMEDIATELY
AVAILABLE

AND

SYSTEM LOAD

HYDRO PLANTS WITH LESS THAN TWO HOURS OF OPERATION REMAINING
MAY NOT BE COUNTED IN THE CALCULATION OF SPINNING RESERVE.

WILL SOLAR PLANTS WITH NO ENERGY IN STORAGE BE COUNTED
IN THE CALCULATION OF SPINNING RESERVE?

DISPATCH STRATEGY
FOR SOLAR STORAGE

THE OPTIMAL DISPATCH STRATEGY SHOULD MINIMIZE THE UTILITY
AVERAGE BUSBAR ENERGY COST OR MAXIMIZE THE VALUE OF THE
SOLAR PLANT.

THE OPTIMAL DISPATCH STRATEGY MUST CONSIDER APPROPRIATELY
THE FOLLOWING GOALS:

- PLANT OUTPUT MAXIMIZATION -- "SUN FOLLOWING"
- RESERVE CAPACITY MINIMIZATION -- "PEAK SHAVING"
- FUEL COST MINIMIZATION -- "ECONOMIC DISPATCH"
(INCLUDING SPINNING RESERVE)

THIS PAGE
WAS INTENTIONALLY
LEFT BLANK

Paper 2-3

THERMAL STORAGE COST/TEMPERATURE TRADEOFFS FOR
SOLAR TOTAL ENERGY SYSTEMS (STES)*

M. Donabedian

THERMAL STORAGE APPLICATIONS WORKSHOP
Solar Energy Research Institute
Golden, Colorado
14-15 February 1978

*This work was performed at The Aerospace Corporation under Contract No. EY-76-C-03-1101 for Division of Solar Energy, Energy Research and Development Administration.

ABSTRACT

The Solar Total Energy System (STES) mission analysis being performed by The Aerospace Corporation involves the identification and selection of appropriate STES applications, economic analysis, and the assessment of industrial market potential. One of the key technical areas involving industrial application is the requirement for high temperature storage, its related cost and its effect on industrial market potential.

This paper presents an analysis of the cost of high temperature sensible heat storage systems in the range of 400°F to 900°F and also presents a summary of the effect of storage temperature on STES industrial market potential.

I. INTRODUCTION

A Solar Total Energy System (STES) is characterized by the use of solar energy for on-site generation of electricity, with recovery and reuse of turbine waste heat to meet thermal demands such as process heat, space heating and cooling, and water heating. Further, when industrial applications are considered which require relatively high temperature process energy, thermal demands may be provided directly from the collector or storage system. The STES Mission Analysis being performed by The Aerospace Corporation involves the identification and selection of appropriate STES applications, and the assessment of STES market potential.

One of the key technical areas affecting the industrial applications of STES is the requirement for high temperature storage and its related cost. Requirements for storage have been previously reported (Ref. 9). This paper discusses an analysis that was performed to develop a more detailed understanding of the effect of STES maximum operating temperatures on high temperature storage costs. Storage subsystem costs are developed for various sensible heat thermal storage fluids (alone and in combination with rocks) as a function of maximum operating temperature. Included in the calculations are cost of tankage and insulation, initial fluid charge, and periodic fluid replacement due to decomposition of the fluid at high temperatures. This study was limited to a sensible heat fluid system because it currently exhibits the lowest level of technical risk and has been selected as the preferred approach for the 10 MW_e solar thermal electric pilot plant in Barstow, California.

Summary data are also presented on the effect of storage temperature on industrial market potential based on a separate study.

A. A SOLAR TOTAL ENERGY SYSTEM FOR INDUSTRIAL APPLICATIONS

A conceptual STES for industrial application requiring both a high temperature and low temperature thermal energy is illustrated in Fig. 1. In the concept shown, a common fluid is utilized in the collector and high temperature storage system. The high temperature storage system supplies energy either to a high temperature thermal load and/or into a Rankine cycle organic fluid power generating system.

A low temperature water loop is used to absorb the Rankine cycle condenser heat which is collected and stored in a low temperature storage system. The low temperature storage is then utilized to provide additional energy for low temperature thermal process loads and/or for space and domestic water heating, or to power absorption refrigeration systems. Alternate concepts using a central receiver/heliostat system utilizing steam and indirect heat exchangers for coupling to the high temperature storage system have also been utilized in mission analysis studies.

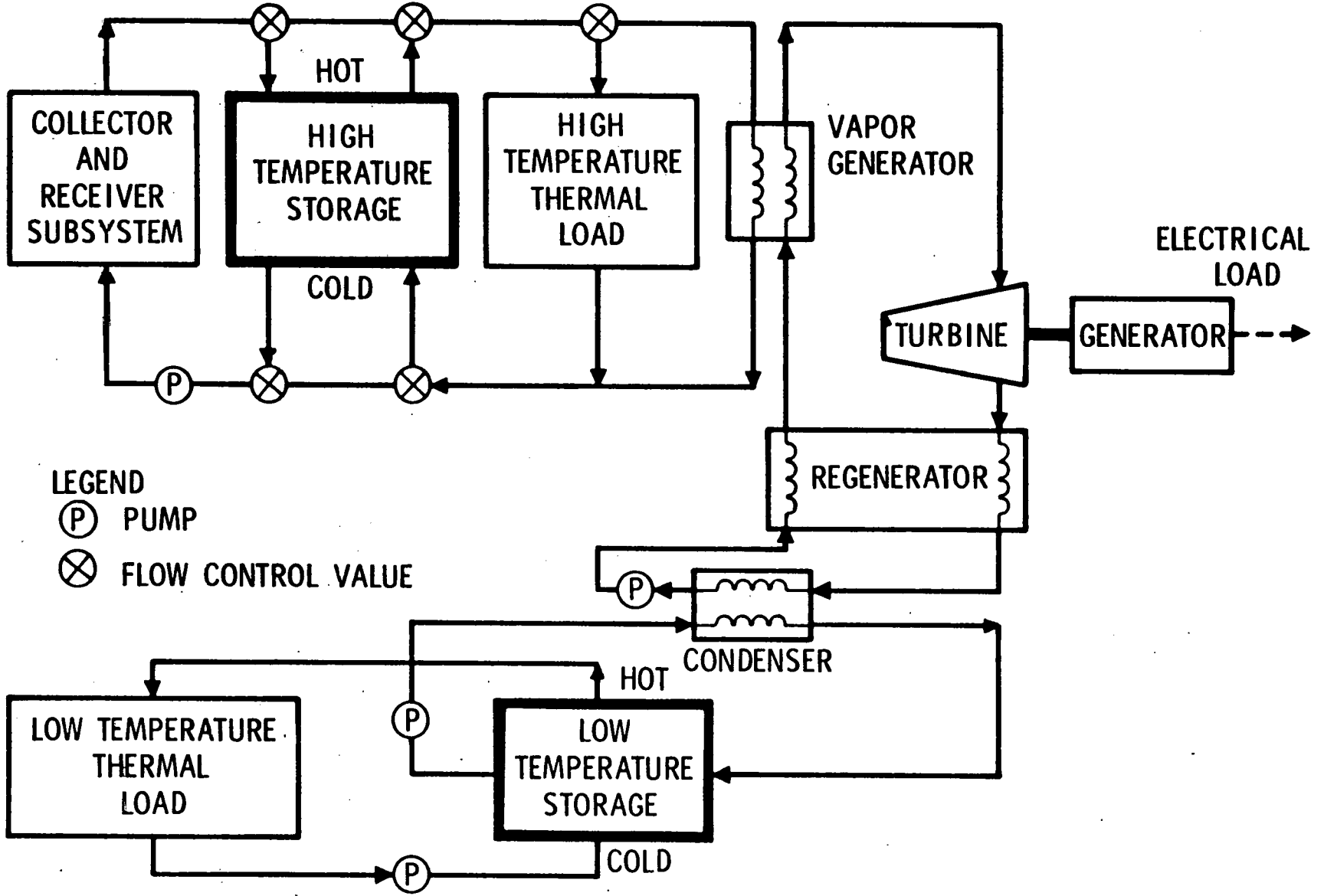

Fig. 1. Solar Total Energy System (STES) for Industrial Application (Organic Storage and Rankine Loop)

II. HIGH TEMPERATURE THERMAL STORAGE FLUIDS

A. FLUID CHARACTERISTICS

A number of fluids have been considered for use as a sensible heat storage medium; they include water, molten salts, liquid metals, conventional hydrocarbons (e.g., jet fuels), and various types of heat transfer oils. Although each of these may be appropriate under certain specific conditions, many of these fluids can be excluded because of one or more factors such as high vapor pressure, poor stability, safety, materials compatibility, operational restraints, availability, or cost. The candidate materials remaining are conventional heat transfer oils such as the Therminol family of fluids (Monsanto Chemical Company), Caloria HT-43 (Exxon Corporation), Dowtherm A (Dow Chemical Company), a molten salt such as HITEC (E. I. DuPont), water, ethylene glycol-water solutions, or a combination of any of the above with crushed rock to reduce storage cost. A summary of some of the pertinent characteristics of these materials is presented in Table 1, and additional discussion follows in the paragraphs below.

1. Heat Transfer Oils

The fluids of most interest in this category include Therminol 55 and 66 (T-55 and T-66), Caloria HT-43 and Dowtherm A. All these fluids have similar volumetric heat capacities and can be utilized over a relatively wide range. In order to minimize oxidation, an inert gas blanket (normally N_2) is required. T-55 and T-66 are useful from about $30^\circ F$ to the range of $500^\circ F$ to $600^\circ F$, depending on the useful life required. One practical limitation of T-66 is its relatively high cost (i. e., \$5.67/gal). T-55 is considerably cheaper at about \$1.80/gal but exhibits a somewhat higher degradation at elevated temperatures.

Caloria HT-43, marketed by Exxon Corporation and formerly known as Humbletherm 500, has been used for a number of years at moderate temperatures, but only limited documented information is available on its stability

Table 1. Summary of Pertinent Fluid Properties¹

Property	Units	Therminol 66	Caloria HT-43	Dowtherm A	HITEC	Water (@200°F)	60% Ethylene Glycol, 40% Water (@200°F)	Crushed Rock
Density	lb/ft ³	51.3	43.4	53.1	118	60.2	64.0	147 ²
Specific Heat	Btu/lb-°F	0.575	0.7	0.53	0.36	1.0	0.83	0.27
Volumetric Specific Heat	Btu/ft ³ -°F	29.5	31.5	28.1	43.7	60.2	53.1	30.9
Thermal Conductivity	Btu/hr-ft-°F	0.064	0.07	0.065	0.242	0.395	0.21	1.5
Viscosity	Centistokes	0.55	1.02	0.42	2.33	0.30	0.90	----
Boiling Point at One Atmosphere	°F	645 ⁴	625 ⁴	500	1500+	212	232	----
Freezing Point	°F	-18 ³	15 ³	53.6	288	32	-65	----
Vapor Pressure	psia	1.93 ⁴	1.5 ⁴	15.7 ⁴	----	13.5	9.5	----
Operating Range	°F	0-650	30-600	450-750	300-900	40-100	-65-320	2000+
Approximate Cost	\$/gal	5.67	1.40	5.17	4.97 ⁵	----	0.90	0.10 ⁶

¹ Properties are given at 500°F unless otherwise noted.

² Bulk density for 25% voids

³ Pour point

⁴ For 10% weight loss

⁵ Based on 31.5 cents/lb

⁶ Based on \$13.00/ton and 25% voids

and materials compatibility characteristics at elevated temperatures. The fluid has been recommended for use up to about 600°F. Based on a cost of about \$1.40/gal, Caloria HT-43 appears to offer the lowest cost heat transfer oil storage medium.

Dowtherm A, which is a eutectic mixture of 73.5% diphenyl oxide and 26.5% diphenyl, is one of the oldest and most widely used organic heat transfer fluids in the chemical process industries. The manufacturer, Dow Chemical Company, suggests use of the fluid in the temperature range between 450°F and 750°F. Dowtherm A has a substantially higher vapor pressure than the Therminols or HT-43 and requires pressurization above 500°F. At 750°F, for example, the vapor pressure is approximately 160 psia. Another undesirable property of Dowtherm A is its freezing point of 53.6°F, thus requiring an internal heating system with its various associated operational problems to maintain the liquid phase. The cost of Dowtherm A is approximately \$5.17/gal.

a. Decomposition of Heat Transfer Oils

The heat transfer oils identified above decompose at elevated temperatures to varying degrees. This decomposition is customarily measured by the rate of weight loss based on controlled laboratory testing. Comparative decomposition rates used in this study, shown in Fig. 2, are based on test data reported in Refs. 1 through 4. Notice that, with the exception of Dowtherm A, the rate of weight loss becomes quite significant at temperatures approaching 600°F; thus, the useful life of these fluids is limited to temperatures below 600°F.

2. HITEC

Molten salts have been used for years by the chemical and manufacturing industries in heat transfer systems for the storage of heat. The most common member of the family of inorganic salt mixtures is known as HTS (heat transfer salt), which is a molten water-soluble eutectic mixture used for

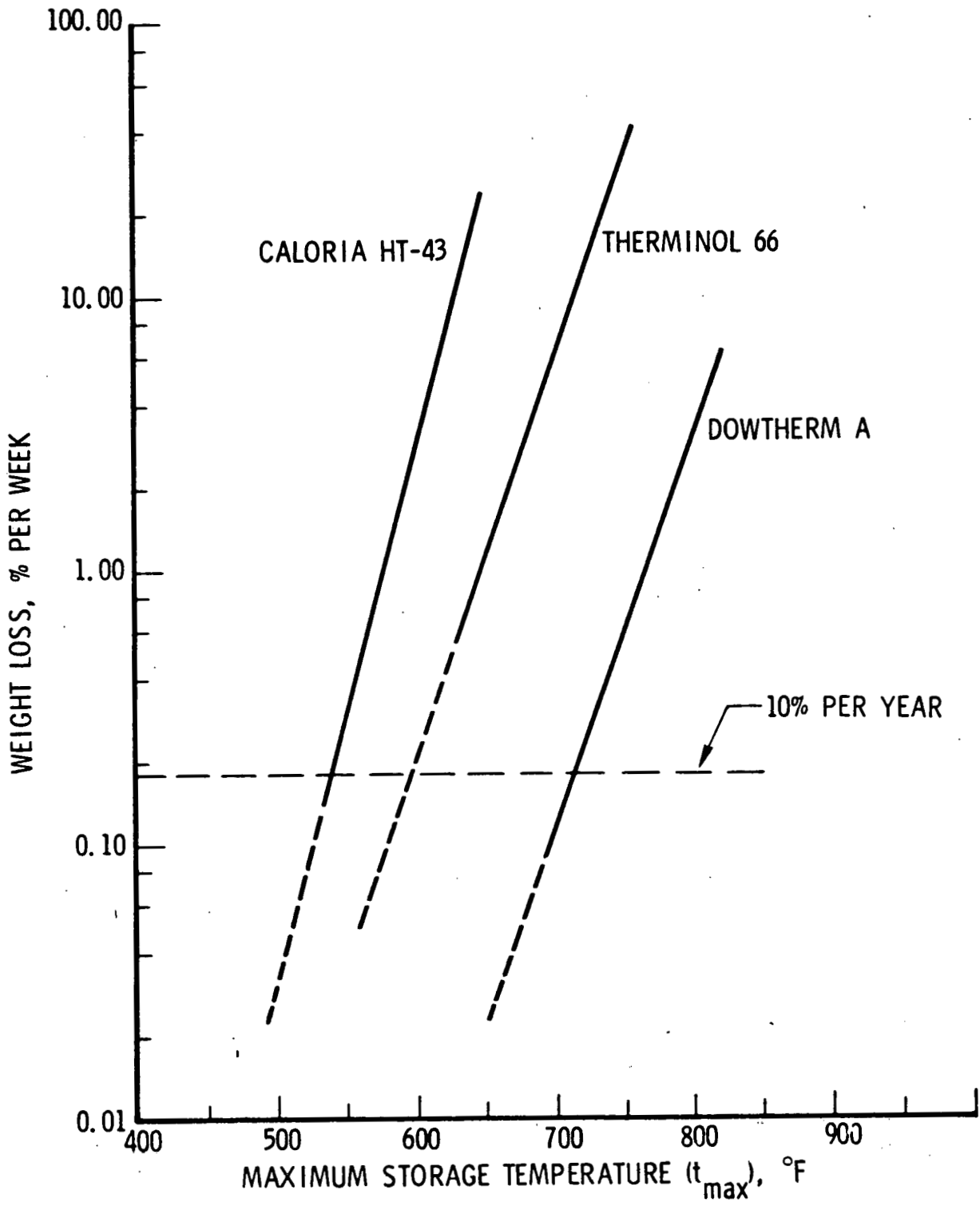

Fig. 2. Comparative Decomposition of Heat Transfer Oils versus Maximum Storage Temperature

heat transfer at atmospheric pressure within a 300°F to 1600°F temperature range. The composition of HTS can vary within wide limits with slight effects on physical properties. The specific mixture which has received the most attention is HTS₁, more popularly known as HITEC, which is a registered trademark of E. I. DuPont. HITEC is a eutectic mixture of 40% sodium nitrite (NaNO₂), 7% sodium nitrate (NaNO₃), and 53% potassium nitrate (KNO₃). This mixture is relatively stable and has essentially unlimited life at temperatures up to 900°F. Other properties are summarized in Table 1.

The freezing point of HITEC is 288°F, although crystals may precipitate out as high as 450°F. Thus, the operational requirements for internal heaters and/or a pump-out system must be considered as an undesirable feature. Another undesirable feature is that the containment vessels must be fabricated from higher cost stainless steels.

3. Water and Ethylene Glycol Water (EGW)

Water is obviously an ideal thermal storage medium at moderate temperatures because of its high specific heat, availability, low cost, et cetera. However, two factors which limit its practical operating temperature range are its relatively high freezing point and its high vapor pressure at elevated temperatures necessitating a pressurized storage system. In addition, corrosion and rust inhibitors are normally required. Although the cost of the high pressure tanks and related components increases significantly with increasing pressure, systems with water have been proposed for use up to 530°F (900 psia) in special applications. For general process use, however, the upper temperature limit is considered to be about 400°F, corresponding to a vapor pressure at 247 psia.

The freezing point can be relatively easily depressed while maintaining reasonably good thermal properties by utilizing an ethylene glycol-water (EGW) solution. For example, the use of 60% glycol solution depresses the freezing point to -65°F but significantly increases the thermal storage cost.

The cost of ethylene glycol in bulk is estimated to be \$1.20/gal (Ref. 4). This fluid will not be considered further in this study, since it is limited to a practical maximum operating temperature of about 320°F.

B. STORAGE SYSTEM COSTS

In sensible heat storage systems, the required volume is inversely proportional to the volumetric heat capacity and the allowable temperature difference (Δt) in the thermal storage media; thus

$$V = \frac{Q}{c_v \cdot \Delta t} \quad (1)$$

where

- V = volume (ft^3)
- Q = heat storage (Btu)
- c_v = volumetric specific heat ($\text{Btu}/\text{ft}^3 \cdot ^\circ\text{F}$)
- Δt = temperature difference between the hot and cold fluid in the tank ($^\circ\text{F}$)

The initial cost of storage can then be computed as

$$C = (7.48)(V)(C_F + C_T) = \frac{(7.48)(C_F + C_T)(Q)}{c_v \cdot \Delta t} \quad (2)$$

where

- C = cost of fluid (and rock) and tankage (\$)
- C_F = cost of the fluid (and rock) (\$/gal)
- C_T = cost of the tankage which includes insulation and supports (\$/gal)
- 7.48 = conversion factor (gal/ft^3)

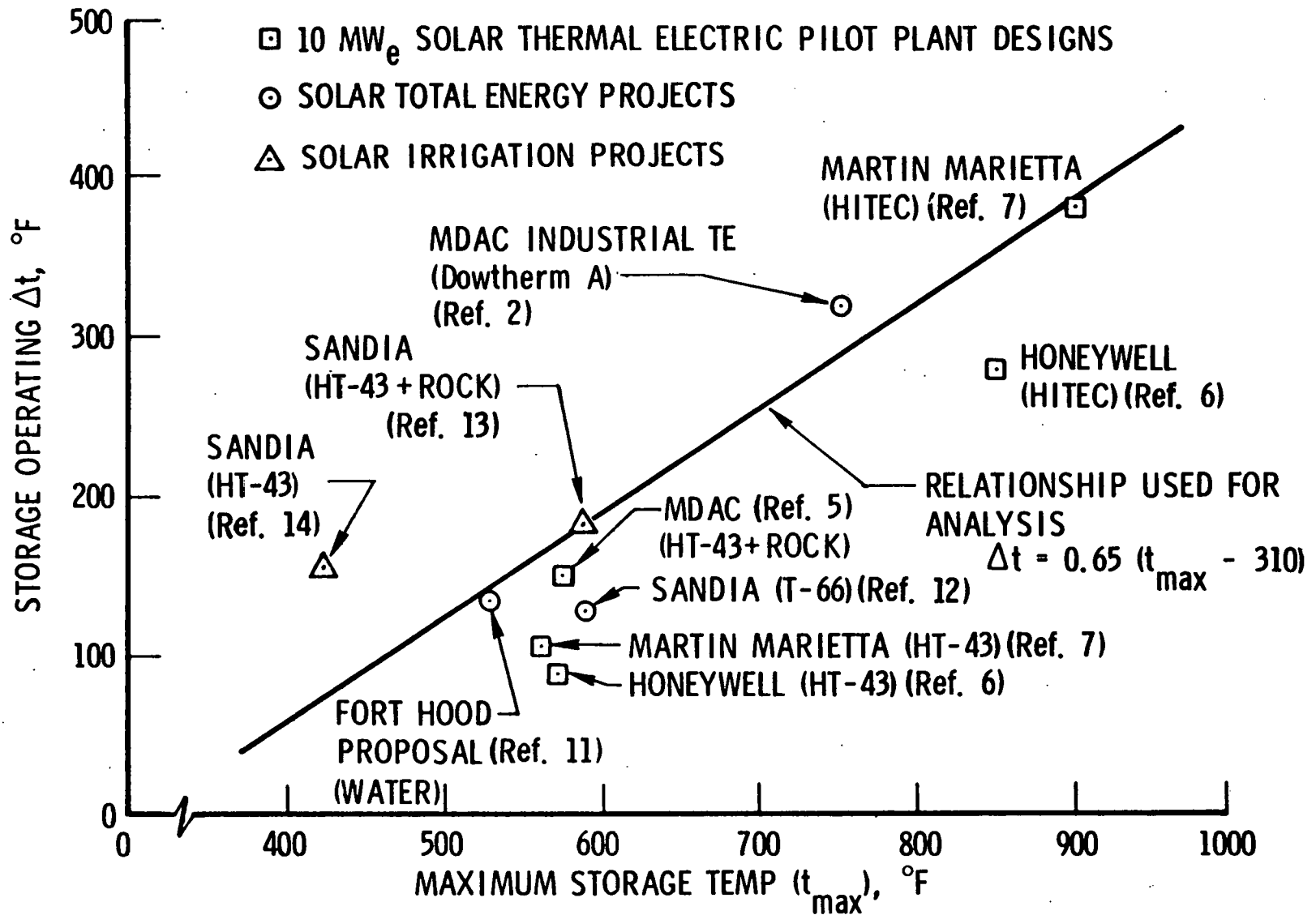

Fig. 3. High Temperature Thermal Storage, Operating Δt versus t_{max}

In order to determine how storage cost is influenced by the maximum storage temperature (t_{\max}), two additional factors are required: (1) the variation of Δt with t_{\max} , and (2) the fluid replacement cost due to decomposition of certain organic fluids at elevated temperatures.

The variation in thermal storage operating Δt with t_{\max} was examined for various solar thermal systems including total energy and solar thermal pilot plant power generating systems as well as solar irrigation concepts in order to provide a realistic basis of evaluation. The type of application, storage medium and the source of the data points are shown in Fig. 3. Based on these data points, a simple straightline relationship between Δt and t_{\max} was defined (indicated on Fig. 3) as follows:

$$\Delta t = 0.65 (t_{\max} - 310) \quad (3)$$

With substitution of Eq. (3) into Eq. (2), the initial cost of storage can be determined in terms of c_v , t_{\max} and the cost per gallon of the storage medium and tankage.

The annual replacement cost of fluid due to decomposition at elevated temperatures can be defined in terms of the weight loss percentage per year, the initial volume of fluid and the bulk cost of the fluid. The weight loss (percent per week) used as a basis for analysis for Caloria HT-43, Therminol 66 and Dowtherm A are given in Fig. 2.

For fluid/rock combinations, the total volume required is based on the effective volumetric heat capacity of the combination (based on 25% voids for the rocks). The initial fluid volume is then 25% of the total volume. Based on review of detail cost data and system descriptions of 10 MW_e pilot plants in Refs. 5 through 7, the cost of tankage (which includes the tank, supports, and insulation) was assumed to be \$1.50/gal in this analysis.

A cursory examination was made initially to determine the relative influence of pressure on the cost of tankage in order that pressurized water systems might also be included. However, the level of detail required to provide realistic cost relationships for high pressure vessels was beyond the scope of this effort.

III. EFFECT OF STORAGE TEMPERATURE ON STORAGE COSTS

The cost of storage in \$/1000 Btu was computed for fluid and fluid/rock combinations using Caloria HT-43, Therminol 66, Dowtherm A, and fluid only (i. e., without/rocks) using HITEC. Bulk costs are shown in Table 1 and are based on quotations from the fluid suppliers. The results for each fluid and/or fluid rock combinations are shown in Figs. 4 through 8. A comparative summary for all the fluids is presented in one chart in Fig. 9. Notice that the initial costs for all the systems can be maintained between \$3/1000 Btu and \$6/1000 Btu over the entire temperature range of 400°F to 900°F. The annual fluid replacement costs, however, are seen to increase very rapidly for the oils as the temperature is increased. If the present value of the annual replacement costs is added to the initial cost of the storage, then the total cost will rise sharply as temperature is increased.

The annual fluid replacement costs shown in Figs. 4 through 8 were converted to present value assuming a 30-year life, 6% inflation rate, and 8% interest rate. The results are shown in Fig. 10 for the lowest cost systems of those examined. Notice that the storage costs including fluid replacement can be maintained at a nominal value of about \$4.50/1000 Btu over the temperature range of 400°F to 900°F by selection of the proper fluid. However, in the operating temperature range of 600°F to 900°F, the use of fluids such as Dowtherm A and HITEC are required. The characteristics of these fluids result in added complexity of storage, which would be expected to increase tankage costs above the nominal value of \$1.50/gal assumed in this study. For Dowtherm A, the complexity involves the requirement for a pressurized system. For HITEC the added problems involve a high freezing point that requires heaters and a pump-out system plus the requirement for stainless steel containment vessels. A more detailed analysis would be required to assess these potential incremental costs.

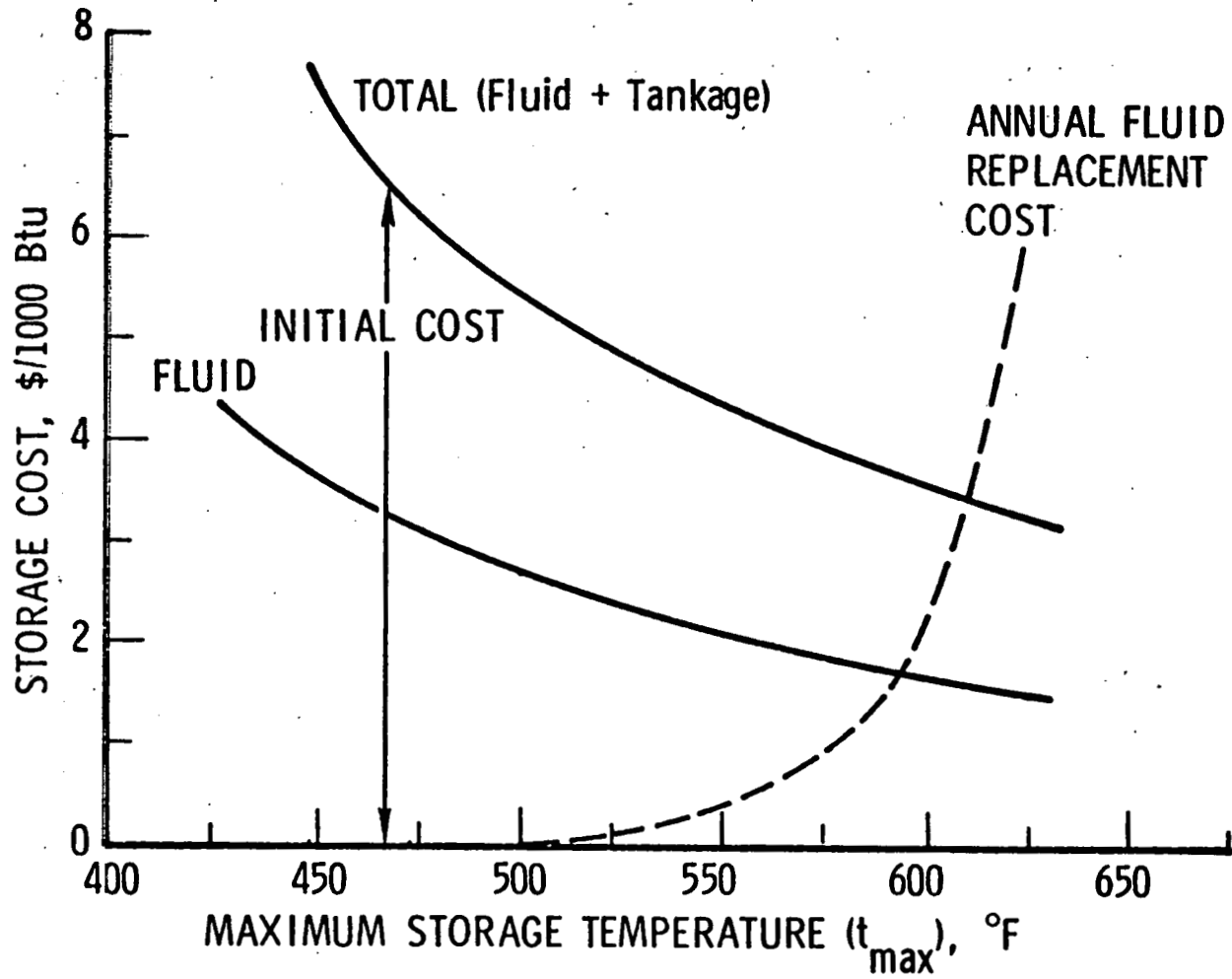

Fig. 4. Storage Costs of HT-43 versus t_{max}

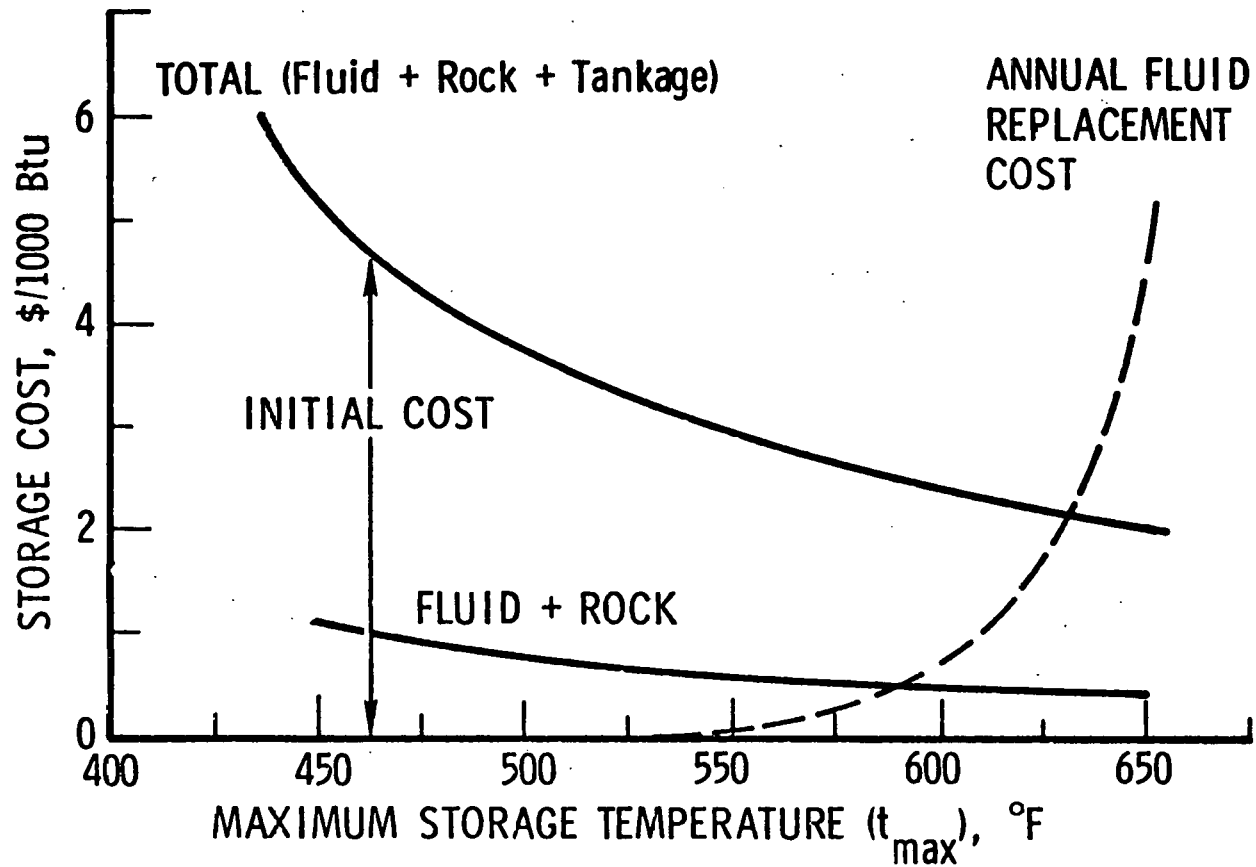

Fig. 5. Storage Costs of HT-43 + Rock versus t_{max}

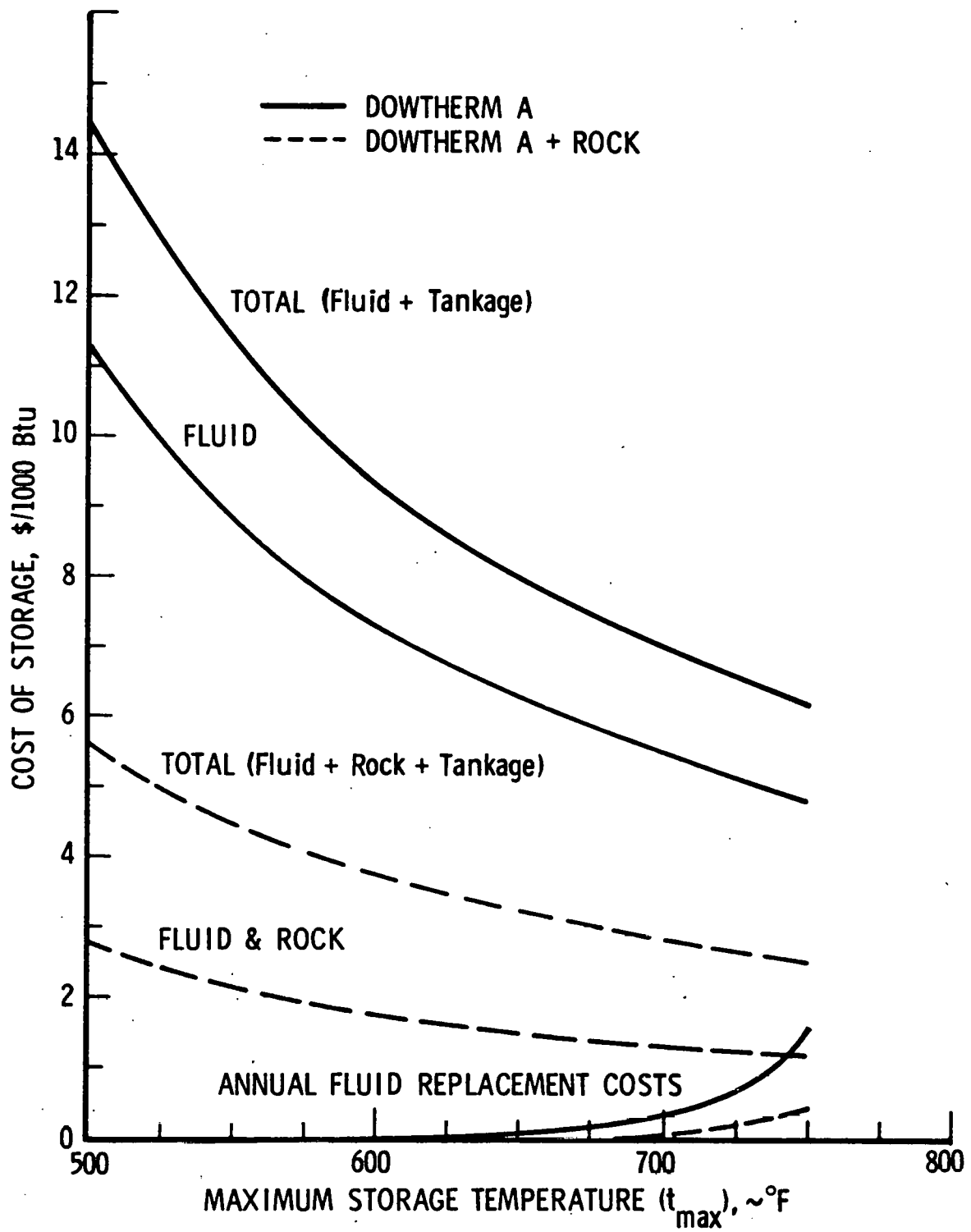

Fig. 6. Storage Cost of Dowtherm A versus t_{max}

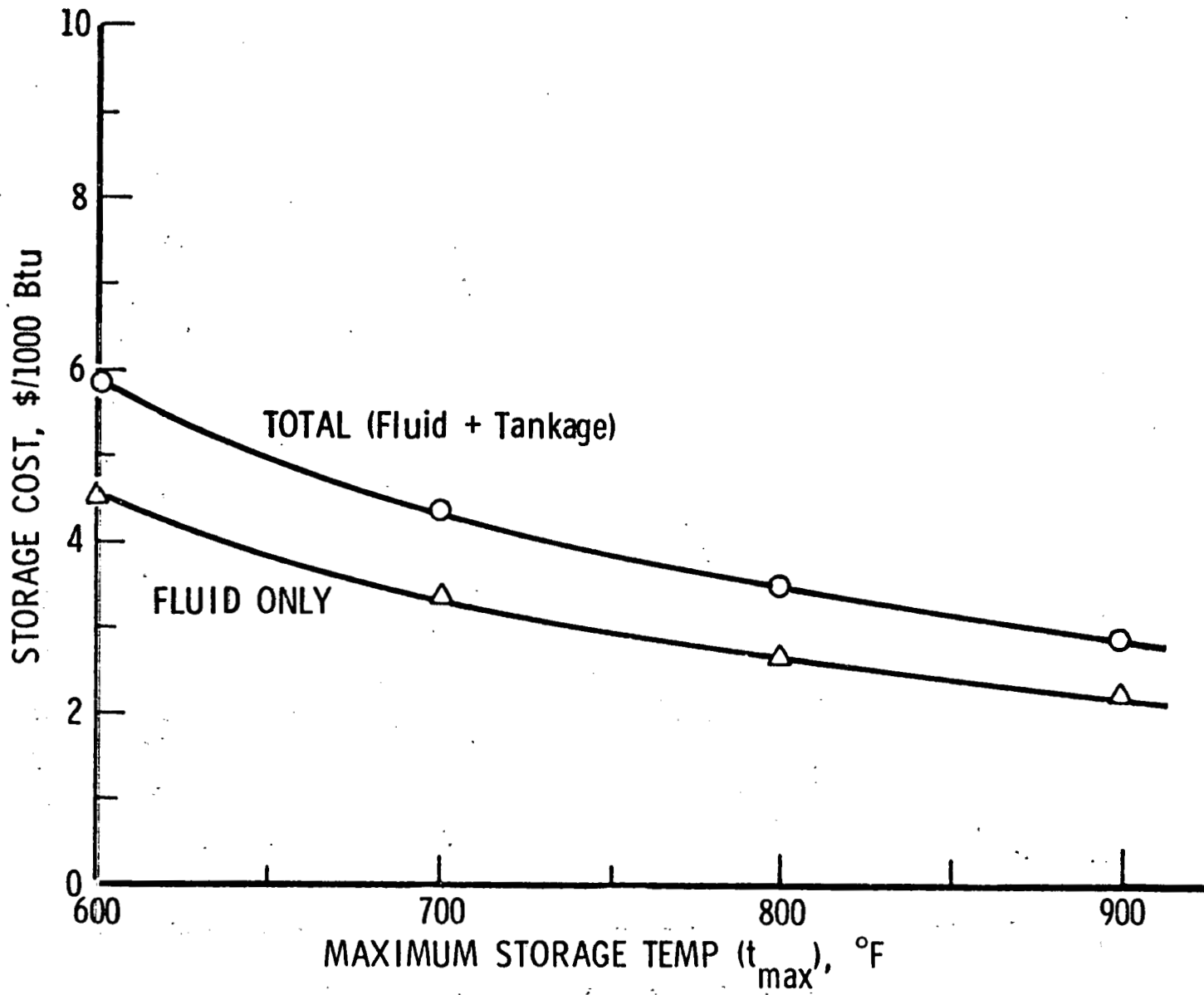

Fig. 7. Storage Cost of HITEC versus t_{max}

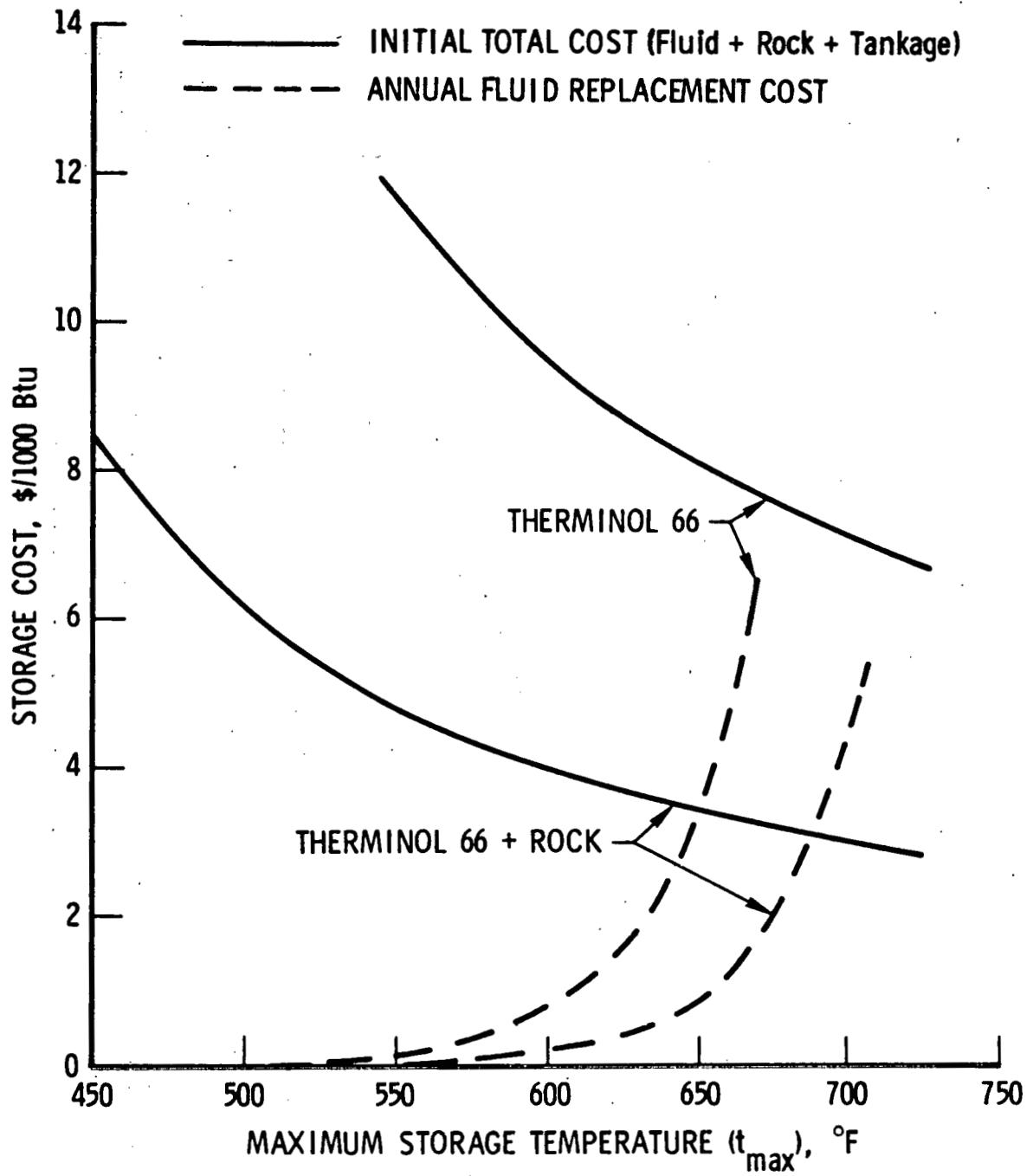

Fig. 8. Storage Costs of Therminol 66 and Therminol 66 + Rock versus t_{max}

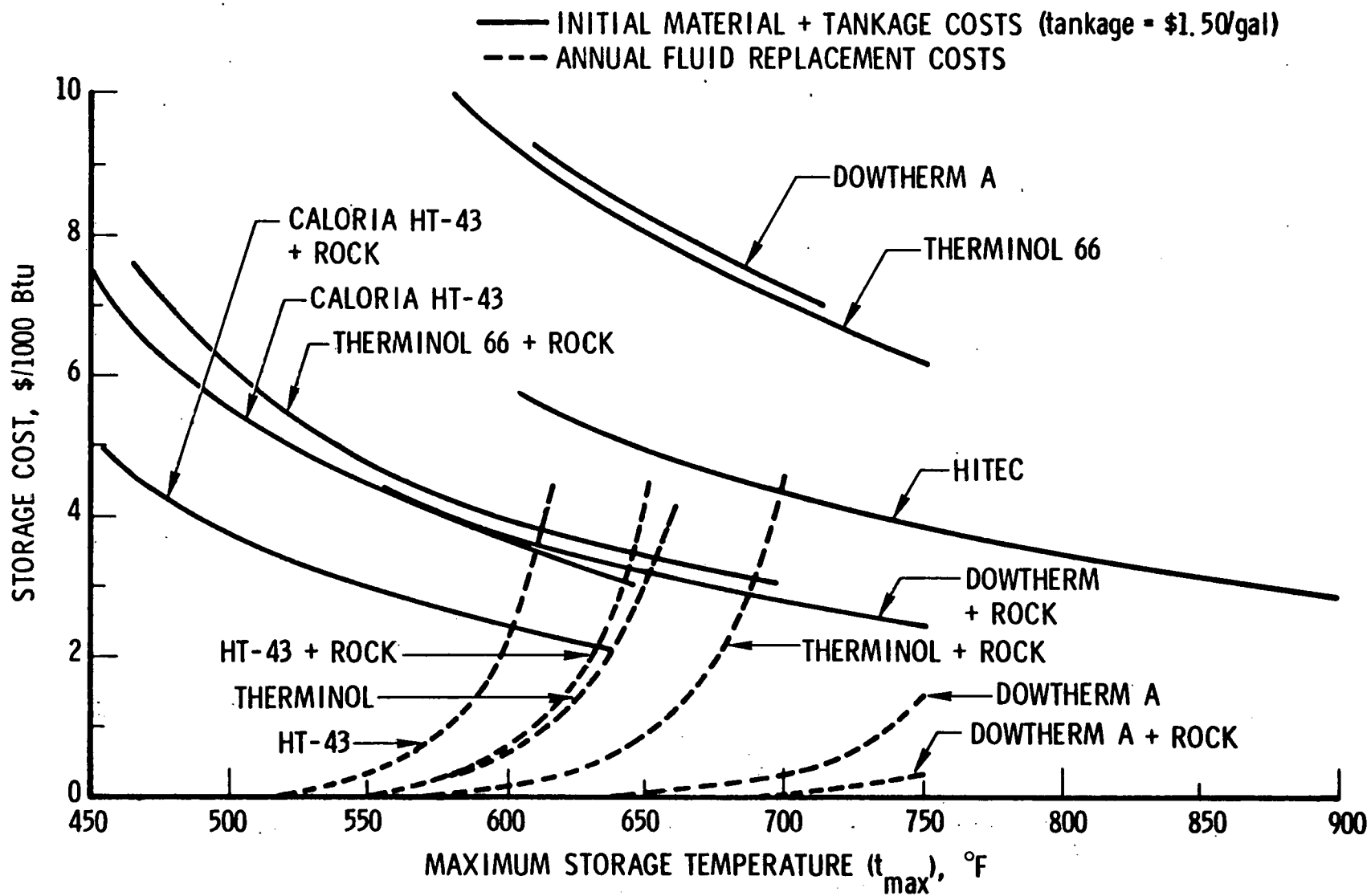

Fig. 9. High Temperature Thermal Storage Costs versus Maximum Storage Temperature

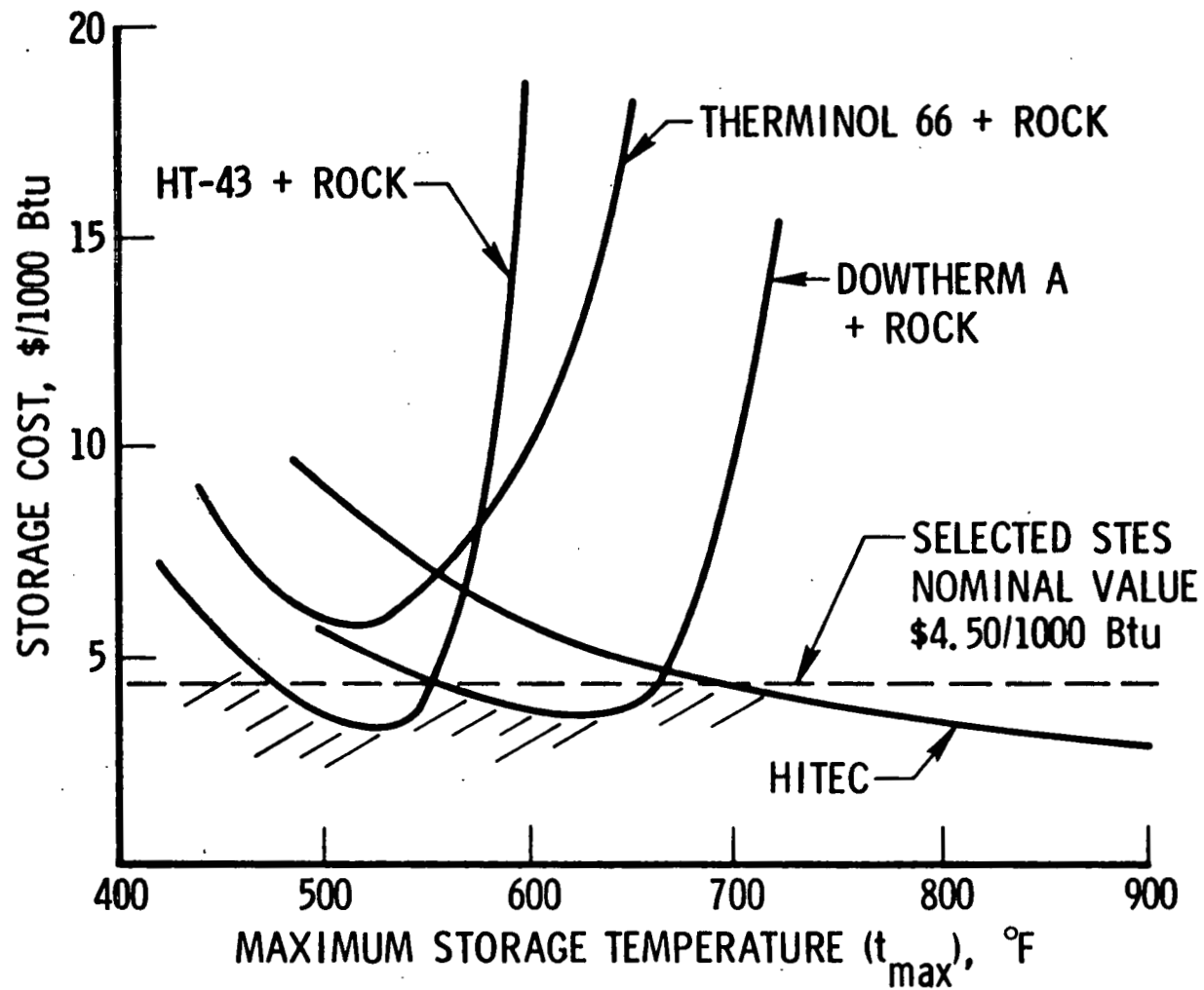

Fig. 10. Total Cost of Thermal Storage versus t_{max} (Including 30-Year Fluid Replacement Costs)

IV. EFFECT OF STORAGE TEMPERATURE ON MARKET POTENTIAL

In order to determine the potential payoffs of utilizing higher storage temperatures, the effect of temperature on the market potential is required. The market potential of STES relative to industrial applications is dependent on the temperature requirements of the industry. Although current solar receiver configurations can practically generate fluid temperatures up to 1000°F, a potential limiting factor is the high temperature storage capabilities and costs.

Based on the data derived from the 1974 Survey of Manufacturers and supplemental data developed by Intertechnology Corporation (Ref. 8), temperature and process energy demand characteristics were developed for over 500 industries. The results, reported in Ref. 9 and summarized in Tables 2 and 3, show that 64% of the industrial total energy use requirements are below 500°F, where all the oils identified can be easily utilized at near minimum cost. Some of the typical industries that utilize process heat below 500°F are shown in Table 4. From Table 5 it can be seen that extension of storage operating levels to 900°F would permit STES applications in cellulose fiber manufacture, metal coatings, and portions of the petroleum refining industry. This could result in an increase of about 10% in STES overall market potential. The remaining 26% of the industrial total energy use requirements range from 900°F to 3300°F.

Table 2. 1974 Industrial Energy Application
(All Temperature Ranges)

<u>SIC</u> *	<u>INDUSTRY</u>	<u>TOTAL ENERGY</u> (kWh x 10 ⁹)
20	FOOD AND KINDRED PRODUCTS	280.2
26	PAPER AND ALLIED PRODUCTS	390.0
28	CHEMICALS, ALLIED PRODUCTS	858.1
29	PETROLEUM AND COAL PRODUCTS	459.4
32	STONE, CLAY, GLASS PRODUCTS	391.5
33	PRIMARY METAL INDUSTRIES	774.0
34	FABRICATED METAL PRODUCTS	120.7
35	MACHINERY, EXCEPT ELECTRIC	107.8
37	TRANSPORTATION EQUIPMENT	109.9
-	ALL OTHERS	433.1
		<u>TOTAL 3924.7</u>

*SIC = Standard Industry Classification

Table 3. Industries Exceeding Process Temperature Requirement of 500°F (Ref. 9)

SIC*	Industry	Temperature Range (°F)	Total Energy (kWh x 10 ⁹)
2823	Cellulose Manmade Fibers	550	19.1
2911	Petroleum Refining	650-1600	435.0
3211	Flat Glass	930-2700	18.9
3221	Glass Containers	1200-2900	41.2
3241	Hydraulic Cement	2300-2700	144.8
3251	Brick, Structural Tile	2500	21.1
3255	Clay Refractories	3300	7.5
3274	Lime	1800	28.7
3295	Minerals, Ground/Treated	1100-1900	9.7
3312	Blast Furnace, Steel Mill	2700	448.4
332	Iron, Steel Foundries	2700	51.8
333	Primary Non-Ferrous Metals	2000-2500	155.7
3479	Metal Coating and Allied	850	5.0
3621	Motors, Generators	1500-1700	5.8
3711	Motor Vehicles and Car Bodies	2650	<u>32.4</u>
			1425.1
U.S. Total, All Industries			3924.7
Percent of High Temperature Industrial Processes Exceeding 500°F			36.3%

*SIC = Standard Industry Classification

Table 4. Some Typical Industries Requiring Process Heat Below 500°F (Ref. 10)

SIC*	Industry and Process	Temperature Range (°F)
3323	Ferrous Coatings, Steel Foundries	300-475
2051	Bread and Baked Goods	420-460
1475	Phosphate Rock, Drying	450
3079	Plastic Products	425
2082	Malt Beverages	400
2611	Pulp Mills, Pulp Digestion	370
2812	Alkalis and Chlorine	350
2653	Solid and Corrugated Fiber	300-350
2951	Paving Mixtures, Aggregate	275-325
2611	Pulp Mills, Paper Drying	290
2611	Pulp Mills, Liquid Treatment	280
2435	Plywood, Drying	250
2611	Pulp Mills, Refining	150
3321	Ferrous Castings, Pickling	100-212
20	Various Selected Food Processing	140-280

*SIC = Standard Industry Classification

Table 5. Industries with Process Temperature Requirements Between 500°F and 900°F

SIC	Industry	Total Energy (kWh x 10 ⁹)
2911	Petroleum Refining	391.5
2823	Cellulose Fibers	19.1
3479	Metal Coating	5.8
		<u>415.6</u>
U.S. Total Industries		3924.7
Percent Energy of Industrial Processes Between 500°F and 900°F		10.6%

V. CONCLUSIONS

Fluid replacement costs were found to significantly increase sensible heat, high temperature storage costs for organic fluids when the fluids are utilized near their upper useful range. A nominal cost of \$4.50/1000 Btu was determined to be appropriate for use in mission analyses in the temperature range of 400°F to 900°F.

Operation of a thermal storage system beyond 600°F, however, requires the use of Dowtherm A for up to 700°F and molten salts such as HITEC for up to 900°F. The characteristics of these fluids result in additional complexity which would be expected to increase tankage costs above the nominal value assumed in this study. A detailed analysis would be required to assess these incremental costs.

A review of temperature requirements for industrial energy use showed that those industries requiring thermal process temperatures (and thereby storage temperatures) below 500°F comprised 64% of the total industrial energy usage. It was further estimated that an extension of the thermal storage temperature beyond 500°F and up to 900°F could result in an increase in STES market potential of about 10%.

REFERENCES

1. "Therminol Fluid Heat Systems," Bulletin IC/FF-31, Monsanto Industrial Chemical Company.
2. "Industrial Applications of Solar Energy," Semi-Annual Report, MDAC-G6383, McDonnell-Douglas Corporation, April 1976.
3. "Pilot Plant Preliminary Design Report, Central Receiver Solar Thermal Power System, Phase I," Martin-Marietta Team Oral Presentation, 27-28 April 1977.
4. Kaufman, K. W., "Some Choice of Materials for Thermal Energy Storage," Solar Engineering, December 1976, p. 19.
5. "Central Receiver Solar Thermal Power System, Phase I," Preliminary Design Review, McDonnell-Douglas Astronautics Company, May 1977.
6. "Solar Pilot Plant," Project Review No. 9, Honeywell, Inc., 4-5 May 1977.
7. "Central Receiver Solar Thermal Power System, Phase 1," Pilot Plant Preliminary Design Report, Martin Marietta, May 1977.
8. Analysis of the Economic Potential of Solar Thermal Energy to Provide Industrial Process Heat, 3 Vols., Intertechnology Corporation, Warrenton, Virginia, 7 February 1977.
9. "Solar Total Energy Systems Technical Progress Report," Aerospace Report No. ATR-77(7692-01)-1, The Aerospace Corporation, El Segundo, California, 1 August 1977.
10. "High Temperature Industrial Process Heat," Aerospace Report No. ATR-77(7523-20)-7, The Aerospace Corporation, El Segundo, California, 1977.
11. "Solar Thermal Total Energy Project," Oral Presentation, American Technological University, 1975.
12. "Solar Total Energy Program, Semiannual Report," Report SAND 76-0078, Sandia Laboratories, Albuquerque, New Mexico, April 1976.

REFERENCES (Continued)

13. "150 KW_e Solar-Powered Deep-Well Irrigation Facility, Phase I-- Preliminary Design Study," Vol. I, Technical Report, Accurex Aerotherm, August 1977.
14. "Solar Powers Irrigation Pumps," Solar Engineering, August 1977, pp. 26-28.

THIS PAGE
WAS INTENTIONALLY
LEFT BLANK

Paper 2-4

THE VALUE OF ENERGY STORAGE FOR DIRECT-REPLACEMENT
SOLAR THERMAL POWER PLANTS*

Truman D. Anderson
Stephen I. Kaplan
John V. Wilson

By acceptance of this article, the
publisher or recipient acknowledges
the U.S. Government's right to
retain a nonexclusive, royalty-free
license in and to any copyright
covering the article.

Paper Presented at the
Applications Workshop: Thermal Storage Integrated
into Solar Power Plants

February 14-15, 1978
at
Solar Energy Research Institute
Golden, Colorado

*Work done at Oak Ridge National Laboratory, operated by Union Carbide Corporation for the Department of Energy.

CONTENTS

	<u>Page</u>
1. INTRODUCTION	1
2. ANALYTICAL MODELS AND ASSUMPTIONS	3
2.1 Treatment of Backup Capacity	3
2.2 Economic Tradeoffs	5
2.3 Defining the Demand Band	8
2.4 Cost and Performance Assumptions	11
3. RESULTS AND CONCLUSIONS	15
3.1 Results	15
3.2 Conclusions	24
REFERENCES	27

1. INTRODUCTION

There are two potential applications of solar-electric power plants in a bulk (utility) power system. One application, referred to as energy displacement, results in a savings of fuel and other variable expenses associated with conventional power plants. The other application, and the one considered in this study, is to use solar power plants to perform the same functions as conventional power plants (direct-replacement or sometimes referred to as capacity displacement). In this latter application, energy storage systems are generally thought to be essential elements of solar power plants. Thus, as a companion program to solar technology development, the Department of Energy is conducting an R&D program on energy storage. The general objective of the present study is to develop information on energy storage requirements as an aid to planning and implementing the research and development work. The specific objectives of the study are:

- To derive cost targets (or what can be afforded) for energy storage systems over a range of applications of direct-replacement solar-thermal power plants.
- To determine the amount of energy storage required for a given cost of storage.

The utility applications considered in this report are base-load (100% demand factor) and intermediate-load (50% and 25% demand factor). Locations examined are Inyokern, Chicago, and Philadelphia. The locations selected are intended to provide a representative sampling of U.S. conditions with respect to both solar resources and utility system load patterns.

A schematic of the solar thermal power plant configuration is shown in Fig. 1. For purposes of economic analyses, the power plant was subdivided

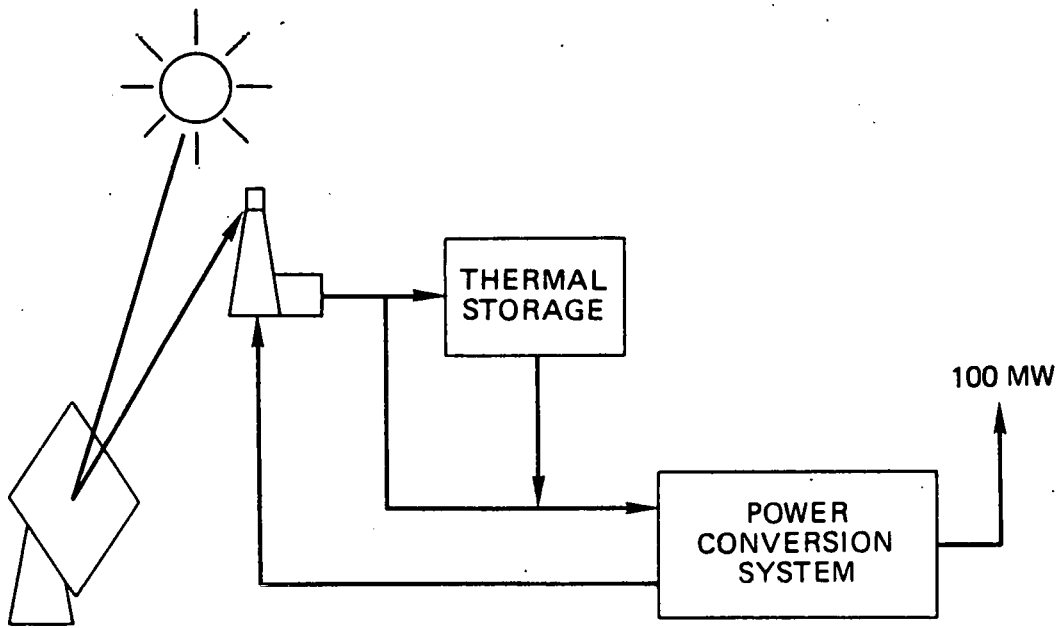

Fig. 1. Solar thermal conversion power plant configuration.

into the following three cost centers: (1) Solar steam supply system, (2) Energy storage system, and (3) Power conversion system. Each solar power plant was assumed to have a power conversion system rating of 100 MW(e).

2. ANALYTICAL MODELS AND ASSUMPTIONS

2.1 Treatment of Backup Capacity

The question of power system reliability must always be addressed when considering solar power plants to perform the same function as conventional power plants. The usual statement of what reliability is required for a power system (not individual plants making up the system) is that failure to meet demand should not exceed one day in ten years. This corresponds to a system reliability of 99.97%. The reliability criterion is met for most power systems consisting of conventional power plants by installing reserve capacity of 15% to 25% of peak demand.

The reason that solar power plants must be given special attention with respect to system reliability stems from the fact that the energy resources for such plants are available only intermittently. But the problem is not that this intermittency necessarily leads to unreliable individual power plants; even with a modest amount of energy storage capacity, solar power plant availability factors, for many applications, can approach those achievable with conventional power plants.* The reliability question with solar power plants comes about because adverse climatic conditions may cause all, or a large portion of, solar power plants in the system to fail simultaneously. If this happens, and if a substantial portion of the system generating capacity comes from solar plants, the system reliability criterion

*This assumes that the Solar R&D program will lead to systems that are as reliable mechanically as conventional power plants.

cannot be met without adding independent backup capacity amounting to about 100% of the solar power plant capacity. The situation is analogous to the case if a utility decided to supply their entire demand from one large conventional power plant. Even though this one power plant might be extremely reliable, there is no chance it could meet the 1 day in ten year reliability required by the system; thus 100% backup capacity would be needed. The alternative in the case of conventional power plants is to meet the demand using a number of smaller blocks of capacity each of which is independent of the others with respect to failures. The key point here is that failures be independent, and it is very difficult to demonstrate that solar power plants located in the same region are independent with respect to solar-resource related failures.

One obvious question related to the above discussion of resource-related failures concerns the effect of energy storage capacity on system reliability. In particular, is it not possible to make the probability of system failure due to lack of solar resources sufficiently small by adding storage capacity? Qualitatively, the answer is that the greater the amount of storage, the more reliable the system,¹ and from a technical standpoint one could add sufficient storage capacity, even in a power system dominated by solar power plants, to satisfy the stringent system reliability requirements. But as a practical matter, the amount of storage required, for a system containing a significant amount of solar capacity, would be much greater than could be economically justified relative to the alternative of providing the necessary backup capacity with combustion turbines. Thus, in this study, power system reliability is provided by 100% backup capacity using combustion turbines.

2.2 Economic Tradeoffs

As noted above, every solar power plant considered in this study consists of solar components plus a combustion turbine with capacity corresponding to the rating of the solar power plant. Thus, with this model there is no question about the reliability of the solar power system; it is just as reliable (actually a bit more so) as a system consisting of conventional coal or nuclear power plants.

Each power plant in a power system is required to produce energy on a schedule determined by the system demand. The question with a solar power plant is what part of this energy demand will be satisfied by solar-derived electricity and what part by the fueled (combustion turbine) backup. The effect of adding more energy storage (and more collection capability to fill the storage) is to increase the solar portion of energy delivered in the demand band. This point is illustrated in Fig. 2 where, for purposes of discussion, a base-load energy demand (100% demand factor) is assumed. With no energy storage and a normal day, approximately one-third of the energy delivered in the demand-band is derived from solar; the remaining energy comes from operating the fueled backup system. Adding 6 hours of storage capacity (6 kW·hr of storage per kW of plant rated output), with an associated increase in collector size to fill the storage, increases the solar contribution to more than half. Further increases in storage capacity increase the solar contribution and decrease the fuel contribution to energy delivered in the demand-band.

The above discussion suggests a basis for determining an optimum solar power plant configuration (storage and collector capacity); the optimization scheme is shown in Fig. 3. As noted previously, an increase in storage and associated collector capacity results in a decrease in the amount and cost of

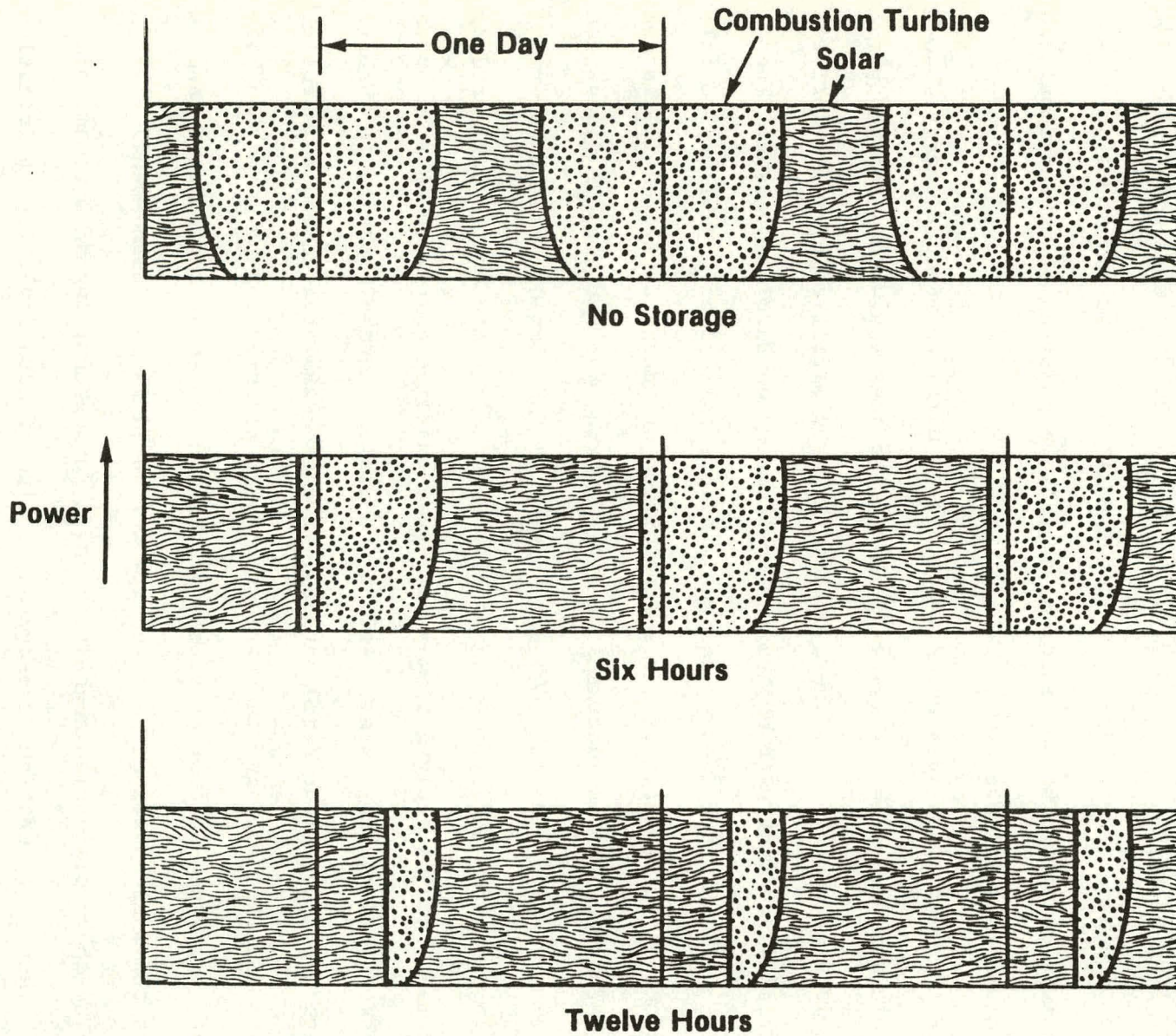

Fig. 2. Illustration of the effect of storage and collector capacity on solar contribution to energy delivered in demand band.

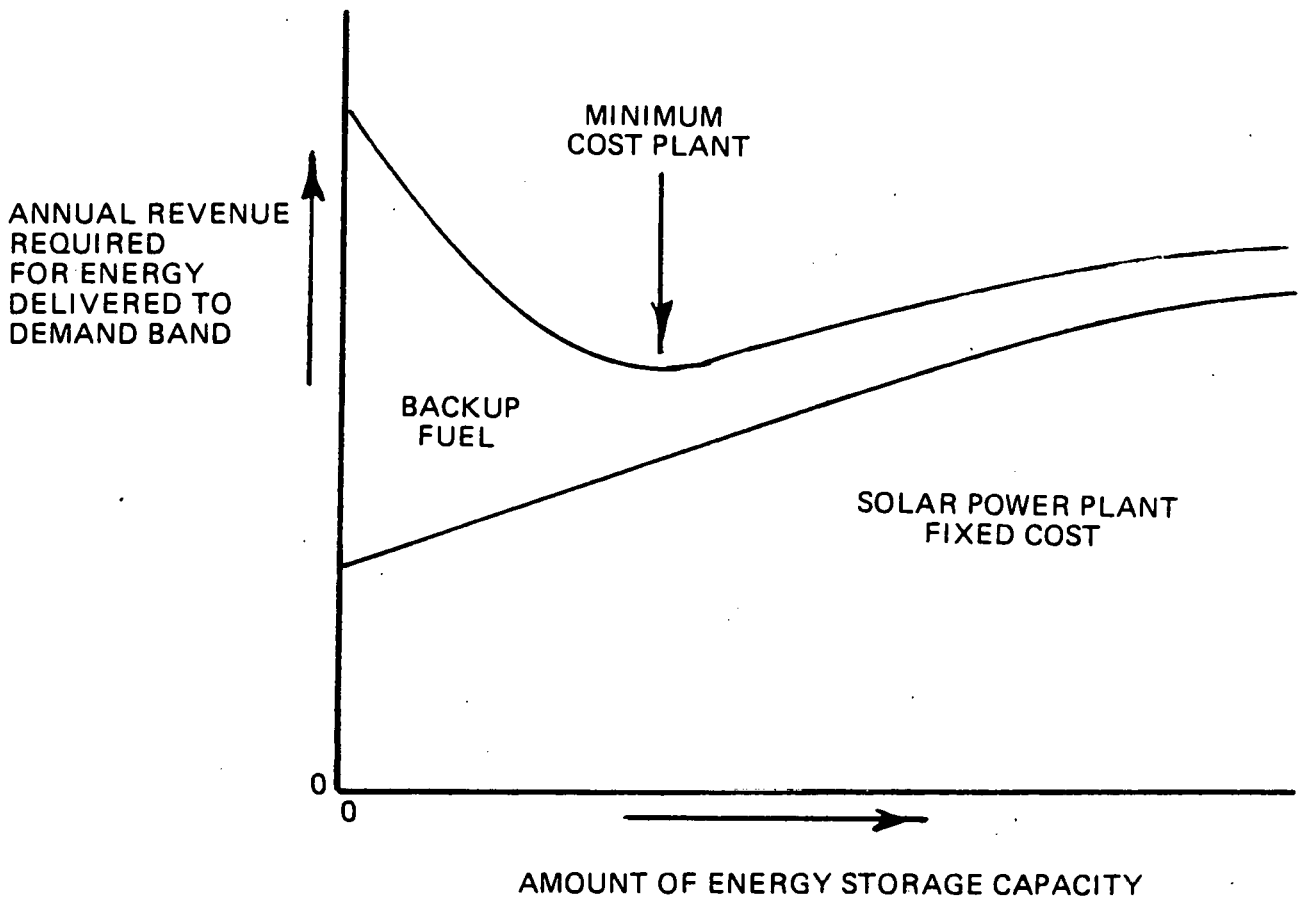

Fig. 3. Effect of increasing storage on elements of energy cost.

the fuel contribution. At the same time, there is an increase in the capital cost of the solar power plant. Thus, there is a tradeoff between capital cost of the solar power plant and variable operating (mostly fuel) cost of the combustion turbine. Generally, a minimum cost for delivering energy into the demand-band occurs, and this represents the economic optimum configuration for the solar power plant.

In addition to determining the optimum amount of storage for a given storage cost and other fixed input data, it is also desirable to know the value of, or how much can be afforded for, storage as a function of energy storage capacity. Figure 4 represents the general shape of the total annual cost of delivering a specified amount of energy on a certain demand schedule excluding the cost (but including the effect) of energy storage; Fig. 4 is identical to Fig. 3 except for the exclusion of the cost of energy storage capacity. If a certain amount of energy storage capacity is selected and this capacity is increased by a small increment, there is a corresponding decrease in annual cost (see Fig. 4). This decrease is the annual value of the last increment of energy storage. The annual value can easily be converted to an equivalent capital investment per unit of storage capacity. Figure 5 illustrates the general shape of the unit value curve. As it turns out this figure has additional utility; if the cost of energy storage is known, and this value is entered on the ordinate, the optimum amount of energy storage may be read on the abscissa.

2.3 Defining the Demand Band

How much energy is to be supplied per year and on what schedule are parameters that need to be established before analyzing solar power plants. For base load power plants, the demand was assumed to be continuous (100%

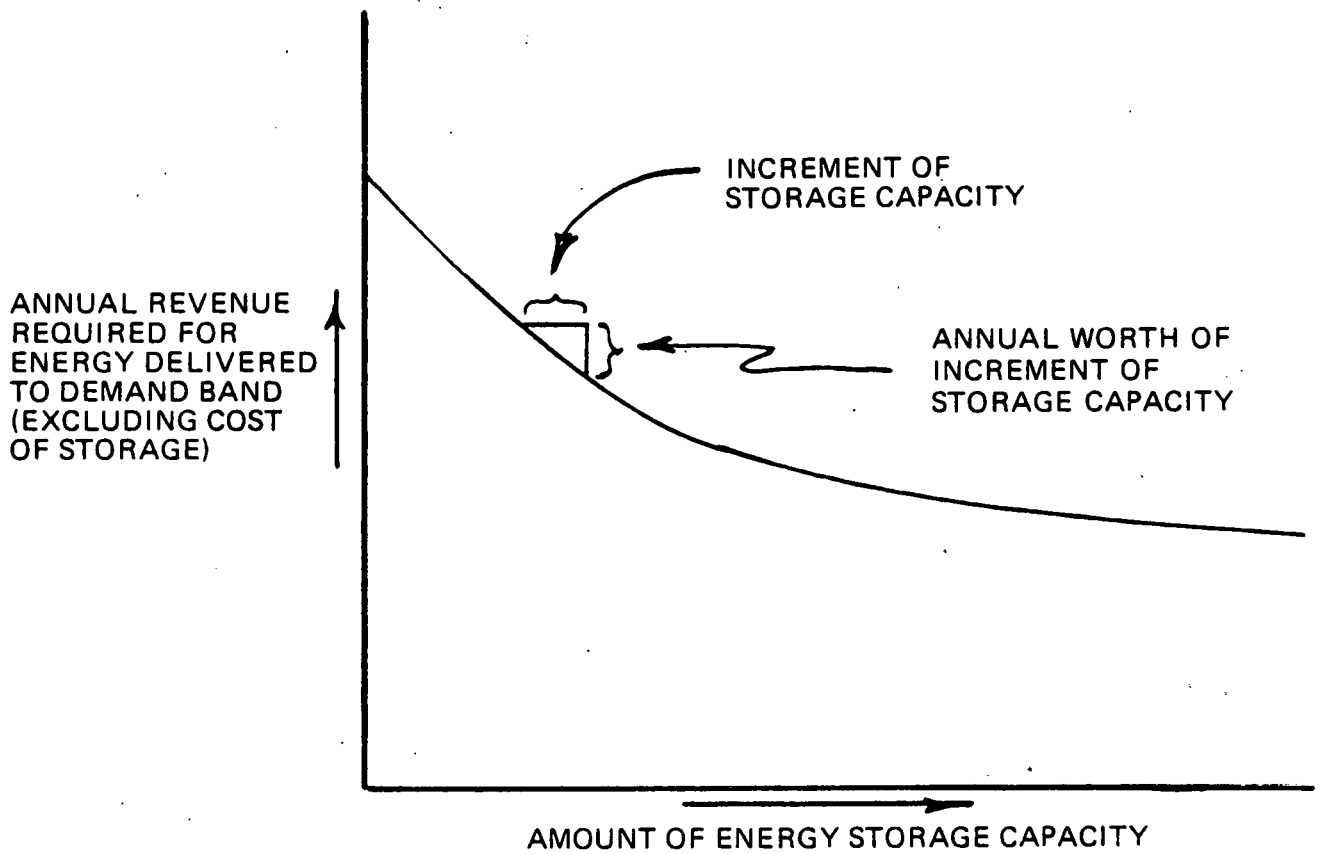

Fig. 4. Method of determining the marginal worth of energy storage.

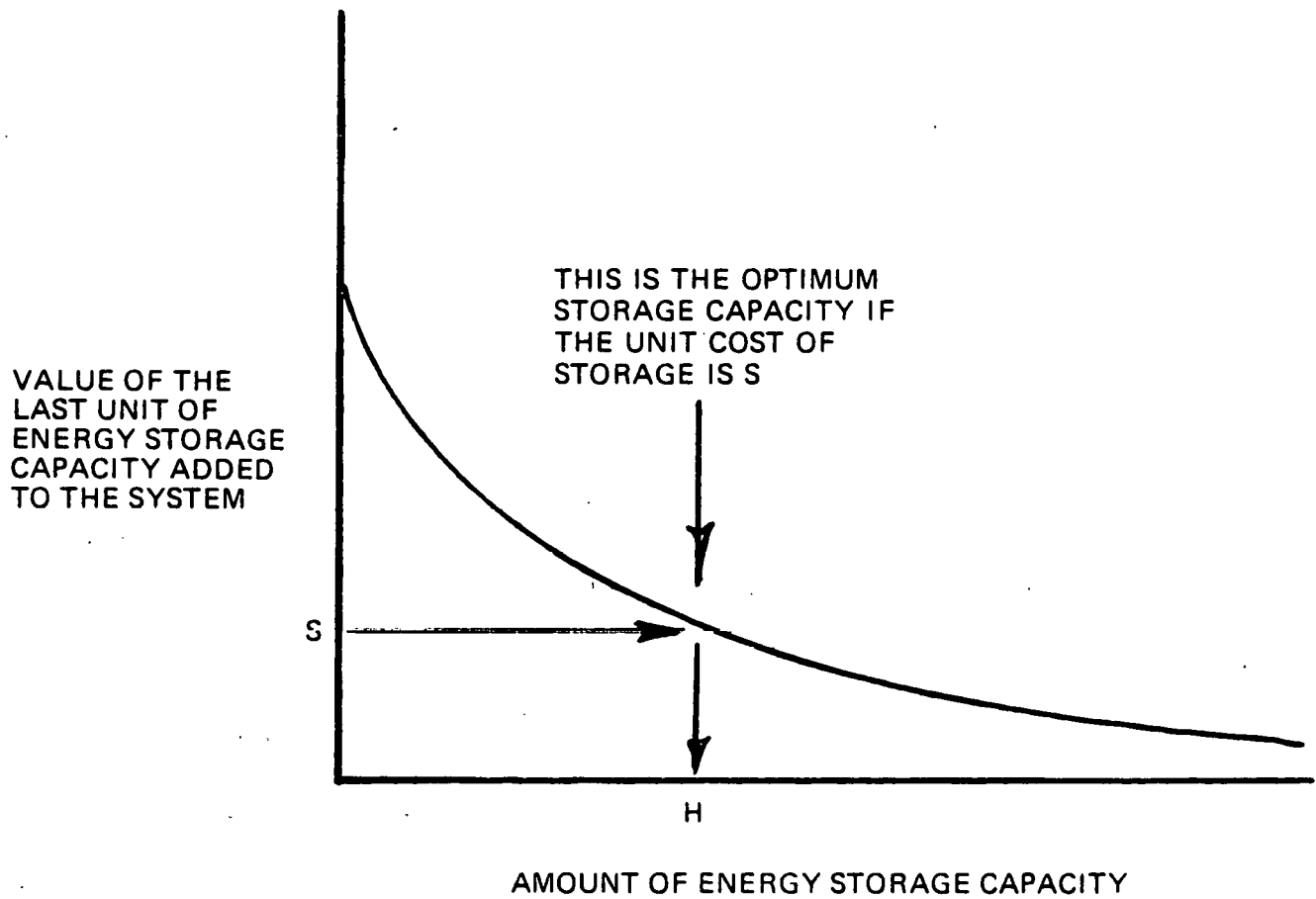

Fig. 5. General characteristics of the marginal worth of storage as a function of storage capacity.

demand factor).^{*} The dispatching model used for intermediate load power plants is similar to the one used by Aerospace Corporation in their mission analysis studies.² With this model it is assumed that when the total power-system demand reaches some prespecified fraction of peak demand for the day, the power plant under consideration is required to deliver its full rated output (see Fig. 6). When the system demand falls below the prespecified figure, the power plant shuts down.

2.4 Cost and Performance Assumptions

Economic Ground Rules

Basic assumptions used in the engineering economic analyses are shown in Table 1. The economic ground rules are typical of those used by investor-owned electric utilities.

Capital, O&M and Fuel Costs

Fuel and O&M cost assumptions are shown in Table 2. A range of fuel prices was considered for both oil and coal. The "low" and "reference" values are from Ref. 1 and represent consistent sets of oil and coal prices (i.e., if combustion turbines are to be used for peaking service and coal for low-intermediate and higher capacity factors, then oil and coal prices are keyed so that each will be an economic choice in its domain). The "high" prices were obtained by simply doubling the reference values. The high oil price (\$48/bbl) might represent a situation where the only oil available is that derived from coal.

The reason coal prices are considered in this study is that the out-of-band energy from solar plants is dumped into the system; the effect is to

^{*}This is not to say that the capacity factor for a solar power plant supplying the demand band is 100%. The capacity factor in this analysis is the product of the demand factor and the mechanical availability factor (assumed to be 88% for all cases).

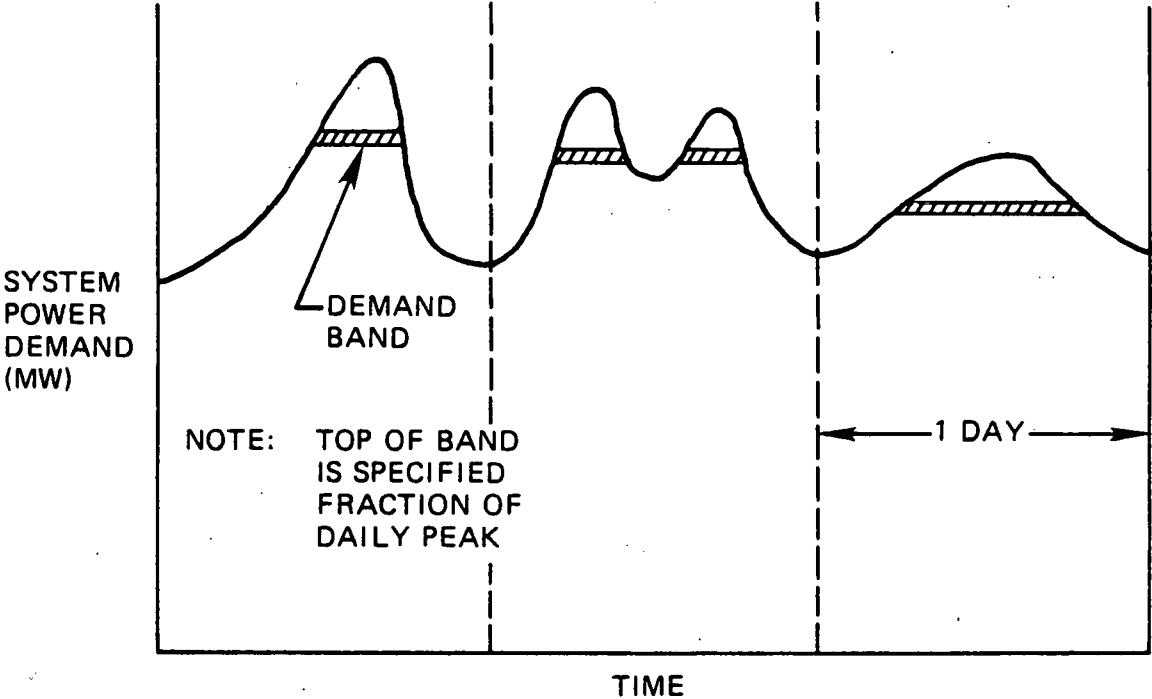

Fig. 6. Dispatching scheme for intermediate load solar power plants.

Table 1. Economic ground rules

Return on equity, %/year	12.0
Interest on borrowed money, %/year	8.0
Fraction of capitalization from debt	0.53
Federal income tax rate, %	48.0
State income tax rate, %	3.0
Escalation rate on all expenses after plant startup, %/year	5.0
Plant lifetime, years	30
Levelizing factor for all expenses	1.593
Yearly charge rate on capital, %	15.5

Table 2. Fuel and O&M costs in terms of 1976 dollars

	Start of operation	30-year levelized
Fuel prices		
Oil for combustion turbine, \$/bbl		
Low	19	30.27
Reference	24	38.24
High	48	76.48
Coal for steam plants, \$/ton		
Low	24	38.24
Reference	53	84.45
High	106	168.90
Variable unit energy costs, ^a mills/kW·hr		
Combustion turbine		
Low	42.9	68.4
Reference	54.3	86.5
High	105.0	167.3
Coal-fired steam plant		
Low	10.8	17.3
Reference	22.2	35.4
High	43.1	68.7
Annual O&M expenses for solar power plants, % of initial investment	1.5	2.39

^aThe variable unit energy costs include fuel and variable O&M costs. All fixed costs are, of course, excluded.

displace energy from fuel-burning plants (mostly coal). This out-of-band energy was valued at the variable operating cost of coal-fired power plants.

Capital cost assumptions are shown in Table 3. A range of costs was assumed for the solar steam supply system since this is the cost element (along with fuel costs) that is instrumental in fixing the value of energy storage capacity.

Performance Assumptions

The performance of each power plant was determined using the Aerospace program "SSM." Power plant characteristics are listed in Table 4.

3. RESULTS AND CONCLUSIONS

3.1 Results

Value of Storage

The marginal worths of energy storage capacity for power plants located at Inyokern are shown graphically in Figs. 7 through 9. Tabular data for all locations and demand factors are given in Tables 5 through 7. Some general observations concerning the results are as follows:

- The value of the last unit of energy storage decreases as storage capacity increases. The reason is that as storage capacity is increased the size of the solar steam supply system that can be justified economically does not increase in proportion to the size of storage. Thus increasing the storage capacity does not result in a proportionate increase in solar-derived energy delivered to the demand band.
- The worth of storage goes up as the cost of the solar steam supply system decreases and as the cost of backup fuel increases. Low-cost collectors and high-cost fuel both favor an increased fraction of energy delivered to the demand-band being solar.

Table 3. Capital cost assumptions

	Low	Reference	High
Solar power plant			
Solar steam supply system, (\$/m ² of collector)	120	150	180
Power conversion system, [\$/kW(e)]		174 ^a	
Thermal energy storage system			
Delivery capability [\$ /kW(e)]		200 ^a	
Storage capacity [\$ /kW·hr(e)]		15 ^b	
Combustion turbine [\$ /kW(e)]		125 ^a	

^aThese numbers have no influence on either the value of storage or the optimum storage capacity.

^bThe assumed cost of storage capacity does not affect the results concerning the value of storage capacity.

Table 4. Plant characteristics

Plant type - central receiver thermal conversion
Fractional ground coverage - 33.5%
Generator capacity - 100 MW
Generator efficiency - 36.2%
Storage efficiency - 85%
Prime reflector efficiency - 88%
Absorptivity - 90%
Emissivity - 95%
Storage energy loss rate - 0.01/hr

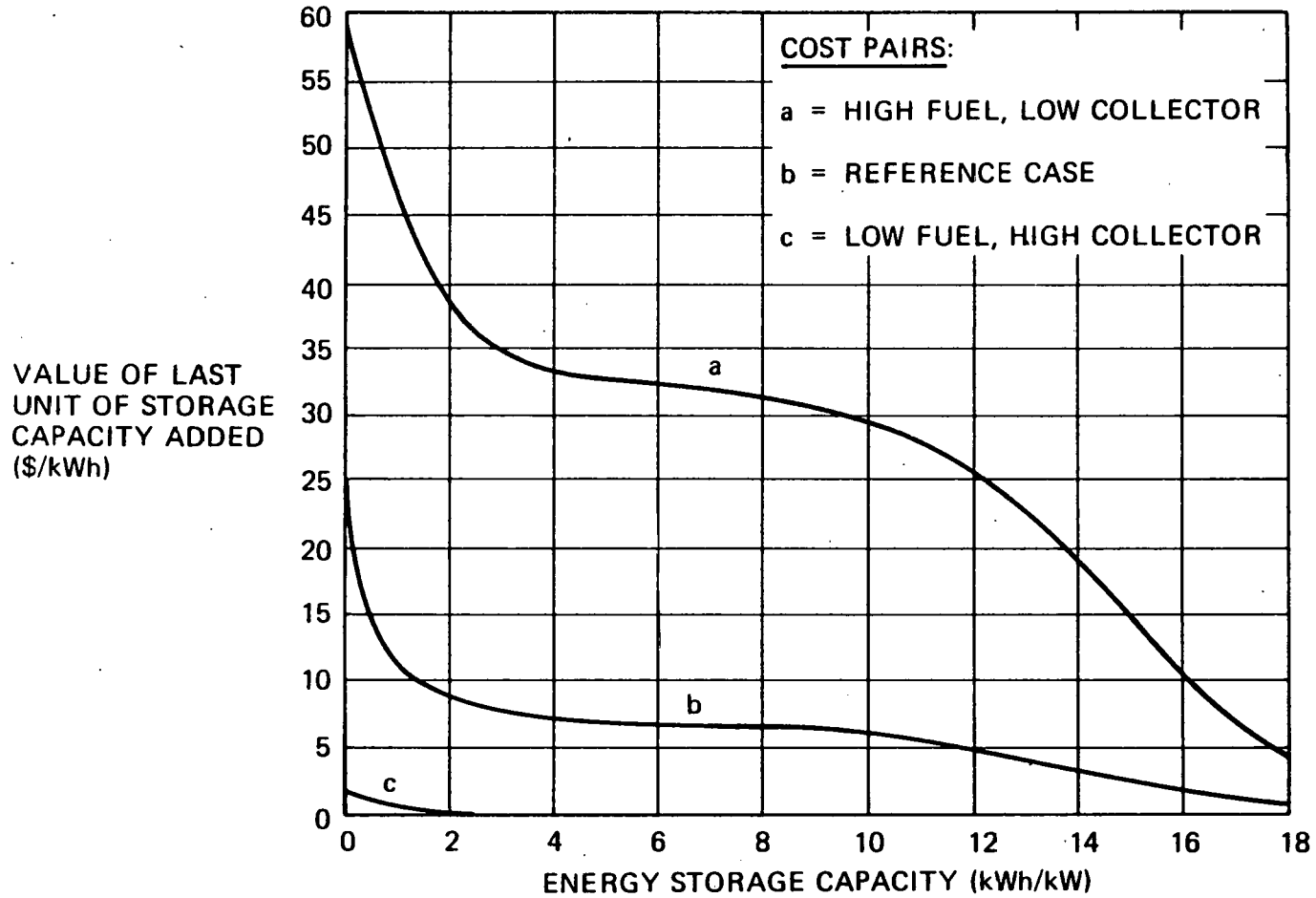

Fig. 7. Value of last unit of energy storage as a function of storage capacity for base load power plant (100% demand factor) at Inyokern.

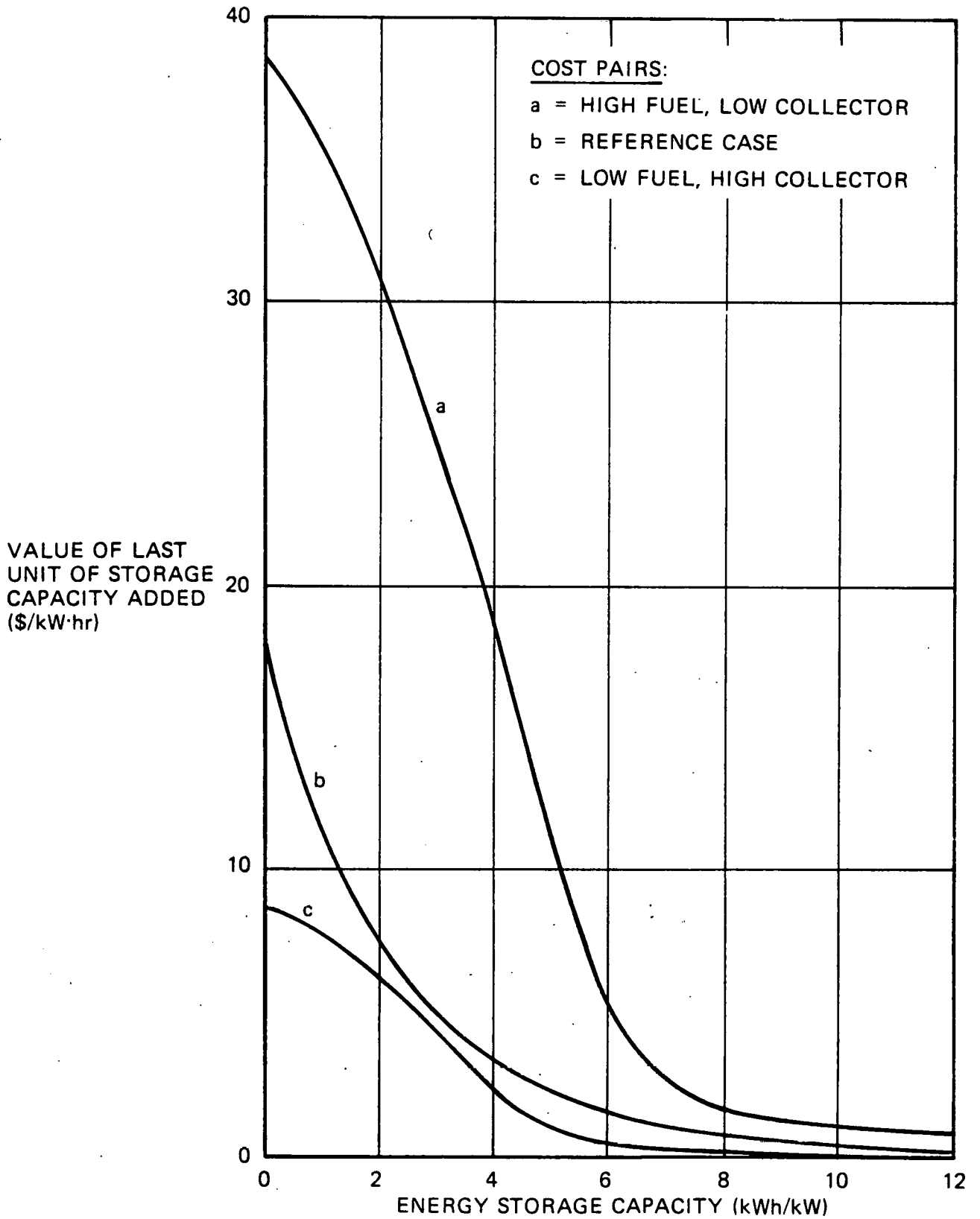

Fig. 8. Value of last unit of energy storage as a function of storage capacity for intermediate load power plant (50% demand factor) at Inyokern.

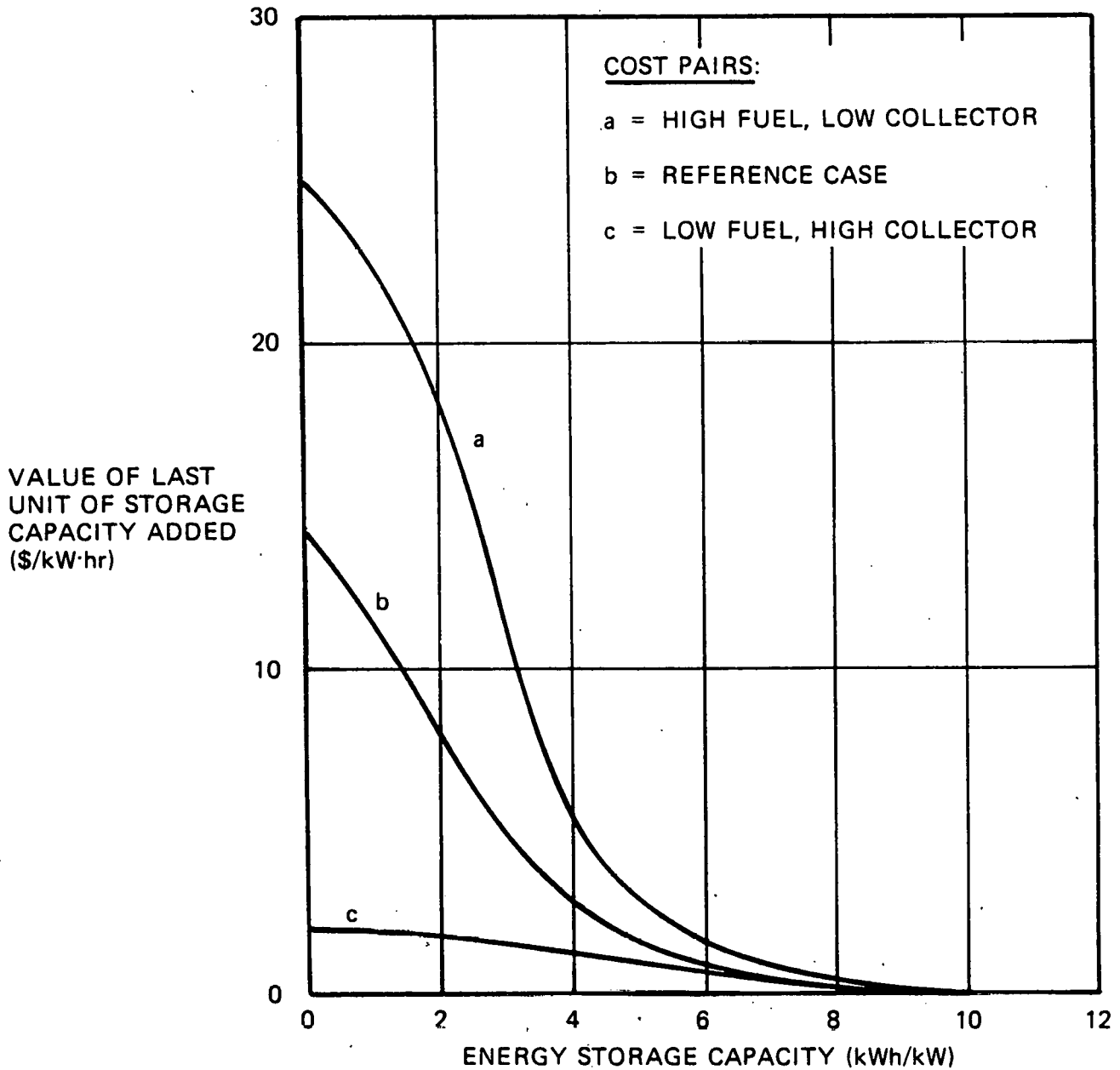

Fig. 9. Value of last unit of energy storage as a function of storage capacity for low-intermediate load power plant (25% demand factor) at Inyokern.

Table 5. Effect of location on marginal worth of energy storage, base-load demand (100% demand factor)

Cost conditions	Storage capacity (kW·hr/kW)	Value of last unit of storage added (\$/kW·hr)		
		Inyokern	Chicago	Philadelphia
High fuel and low collector costs	2	38.60	31.70	29.50
	6	32.80	23.60	22.10
	12	25.70	10.45	13.50
	24	0.19	2.35	4.10
	48	0	0	1.00
Reference fuel and collector costs	2	11.10	1.92	5.10
	6	9.00	0.75	0.54
	12	0.50	0	0
	24	0	0	0
	48	0	0	0
Low fuel and high collector costs	2	0.75	0 ^a	0 ^a
	6	0	0 ^a	0 ^a
	12	0	0 ^a	0 ^a
	24	0	0 ^a	0 ^a
	48	0	0 ^a	0 ^a

^aFor these cases the optimum collector size is zero.

Table 6. Effect of location on marginal worth of energy storage, 50% demand factor

Cost conditions	Storage capacity (kW·hr/kW)	Value of last unit of storage added (\$/kW·hr)		
		Inyokern	Chicago	Philadelphia
High fuel and low collector costs	2	30.60	19.00	20.80
	4	19.00	14.50	15.00
	6	5.30	10.40	10.30
	12	0.72	2.30	2.30
	24	0	0.60	0.70
Reference fuel and collector costs	2	7.30	5.33	3.30
	4	3.50	4.20	2.00
	6	1.50	3.40	0.90
	12	0.25	0.90	0.16
	24	0	0	0
Low fuel and high collector costs	2	6.30	0 ^a	0 ^a
	4	2.20	0 ^a	0 ^a
	6	0.45	0 ^a	0 ^a
	12	0.05	0 ^a	0 ^a
	24	0	0 ^a	0 ^a

^aFor these cases the optimum collector size is zero.

Table 7. Effect of location on marginal worth of energy storage, 25% demand factor

Cost conditions	Storage capacity (kW·hr/kW)	Value of last unit of storage added (\$/kW·hr)		
		Inyokern	Chicago	Philadelphia
High fuel and low collector costs	0	25.00	18.80	31.70
	2	19.00	15.00	11.20
	6	1.70	2.63	4.70
	12	0.35	0.74	0.22
	24	0	0	0.10
Reference fuel and collector costs	0	14.40	6.00	9.60
	2	8.20	2.40	2.90
	6	1.00	0.20	0
	12	0	0	0
	24	0	0	0
Low fuel and high collector costs	0	2.00	0 ^a	0 ^a
	2	1.70	0 ^a	0 ^a
	6	0.68	0 ^a	0 ^a
	12	0	0 ^a	0 ^a
	24	0	0 ^a	0 ^a

^aFor these cases the optimum collector size is zero.

- ° For all locations and demand factors considered in this study, the marginal worth of storage is very low (zero for many cases) when energy storage capacity approaches a day (24 kW·hr/kW). The implication is that, even if energy storage were free, the amount of storage required would be one day or less for most cases.
- ° Although there are some exceptions, storage is generally worth more at "good" solar locations such as Inyokern than at more average solar locations.

Optimum Amount of Energy Storage

Assuming energy storage capacity can be obtained for \$15/kW·hr, the optimum amount of energy storage ranges from 1 kW·hr/kW for low-intermediate load plants (25% demand factor) at Philadelphia to 15 kW·hr/kW for base-load plants (100% demand factor) at Inyokern. These data, shown in Table 8, are based on the low solar steam supply cost (\$120/m²) and the high backup fuel cost (\$48/bbl). As noted previously, these cost conditions favor storage. Higher steam supply costs and lower fuel costs would cause the optimum storage capacities to be less than those shown in Table 8.

3.2 Conclusions

The value of energy storage is strongly dependent on the cost of the solar steam supply system and on the cost of backup fuel. For a given set of these cost factors, the optimum amount of energy storage is a function of the cost of storage. For the range of cost conditions and power plant locations considered in this study, the maximum amount of storage capacity required was estimated to be 15 kW·hr/kW for a base-load plant located at Inyokern. For intermediate-load plants, the optimum amount of storage capacity was estimated to be less than 6 kW·hr/kW. Other studies (see Ref. 3, for example)

Table 8. Optimum amount of energy storage
for high fuel and low collector costs,
storage cost = \$15/kW·hr

Demand factor (%)	Optimum amount of storage ^a (kW·hr/kW)		
	Inyokern	Chicago	Philadelphia
100	15.0	10.0	11.0
50	4.5	4.0	4.0
25	2.5	2.0	1.0

^aRounded to nearest 0.5 kW·hr/kW.

indicate that intermediate-load solar power plants have the best economic potential. It is concluded, therefore, that the energy storage R&D program should focus on storage systems of relatively low capacity, i.e., less than 6 kW·hr/kW.

REFERENCES

1. T. D. Anderson, H. I. Bowers et al., *Summary Report - An Exploratory Study of Cost Targets for Solar Electric Power Plants*, ORNL/TM-5787, Oak Ridge National Laboratory (March 1977).
2. *Mission Analysis of Photovoltaic Solar Energy Systems - Final Report*, Aerospace Report No. ATR-76(7476-01)-1, Vol. II (December 1975).
3. Civil Programs Division, The Aerospace Corporation, *Solar Thermal Conversion Mission Analysis, Volume I: Summary Report*, ATR-74(7417-05)-1 (Jan. 15, 1974).

THIS PAGE
WAS INTENTIONALLY
LEFT BLANK

SYSTEMS ANALYSES OF STORAGE IN
SPECIFIC SOLAR THERMAL POWER
APPLICATIONS

H. M. Dodd
Systems Analysis, Division 5743
Sandia Laboratories, Albuquerque, NM 87115

INTRODUCTION

The purpose of this paper is to briefly outline the solar energy systems analyses efforts being conducted by Systems Analysis Division III, 5743, at Sandia Laboratories, Albuquerque. Special emphasis will be placed on the thermal storage aspects of various programs.

This Sandia division exists primarily to provide systems analysis support to various groups in the Solar Energy Projects Department. Some additional systems analysis and program management is provided directly to DOE Headquarters. The analytical efforts for a project typically consider a number of possible configurations having components of variable size, performance and cost. Normally, the goal of the analysis is to identify the specific configuration which yields the lowest possible cost of the energy produced. Of course, various constraints usually exist and other benefit measures (e.g. fossil fuel displacement) may also play a role in the analysis.

This paper presents three approaches using optimization techniques plus an additional approach which attempts to discover generalized results concerning the appropriate sizes of solar collector and storage medium for a given load. The three optimization techniques either have thermal storage built into the model or (in one case) have a general storage module which can be representative of thermal storage.

The first, and mathematically simplest, optimization model was developed as part of our involvement in DOE's Solar Thermal Irrigation project. The second was developed for the Advanced Physical Methods Branch of the Division of Energy Storage Systems, DOE, and has the generalized storage module. The last, and most complex, analytical tool is presently being developed to assist Sandia's Solar Total-Energy Program Division. The additional effort is an internal activity which seeks to combine the above optimization tools with source/load cross-correlation analysis. Hopefully some simple, straightforward guidelines can be found to aid those not having access to large computers or substantial budgets.

Solar Irrigation

The systems support of the Solar Thermal Irrigation program can best be described as an applications analysis effort. Specifically, the primary goal is to identify the optimum mix of collector area and thermal storage size for various geographic locations, irrigation practices and other pertinent factors. Since the goal of the solar irrigation program is to make the solar system commercially competitive, the systems analysis must also identify those components which have the greatest influence on energy costs, and define appropriate performance/cost goals.

Once an agricultural site is specified, the well depth and water requirements determine the necessary pump size. Thus, for this type of problem, the optimization requires analysis of a two degree of freedom system: collector area and thermal storage size. The best combination of these two variables is influenced by their cost and performance and by various economic and alternate energy conditions. Figure 1 shows the basic power flow for the irrigation concept from which the optimization approach was constructed.

Preliminary results from this study were recently published (ref. 1), and this paper presents some additional findings related to the utilization of thermal storage. For a set of nominal conditions characteristic of irrigation in the Southwest United States, Figure 2 shows the effects of system size on energy costs, storage needs and the fraction of total annual load supplied by the solar system. It can be seen that for small (20 kW) systems, thermal storage of 9-12 hours yields a minimum life cycle cost of energy. At the other size extreme (500 kW), any addition of storage clearly increases energy costs. This variation of storage needs with system size is apparently because the low power system is forced to spend a larger fraction of total capital investment on the 20 kW heat engine. By introducing storage the engine can be run for longer periods of time, effectively reducing the net cost per unit of energy produced.

Solar-Mechanical Energy Storage

The optimization procedures developed under this program are mentioned here to illustrate a case where all components through electrical generation may need to be optimized. Figure 3 shows this lumped parameter model which uses one year of hourly insolation and load demand data for which up to seven independent variables can be considered. These variables are indicated by the rectangular boxes in the figure and are labeled with their generic function.

For a nominal set of economic conditions and component costs and performance (ref. 2), the role of storage was found to be strongly influenced by a number of variables. Sensitivities to solar collector and storage costs, alternate energy prices and other parameters were found to be high. For example, Figure 4 shows how alternate purchased energy prices and storage cost variations affect storage size for optimized solar systems. The particular results shown are for a total tracking focused

collector supplying a portion of the electrical needs of an average house in Albuquerque. While the particular storage considered was a flywheel, the same analytical technique can be applied to other storage types, including thermal storage.

Solar Total Energy

The systems analysis supporting the Solar Total Energy Program represents the most complex modeling of the efforts described in this paper. The degree of complexity is apparent when it is realized that both multiple energy sources and load demands may be a part of a total energy system, as indicated by the simple block diagram in Figure 5. The purpose of this analytical model is to achieve a methodology allowing seemingly diverse solar total energy systems to be objectively compared.

Specifically, the system optimization approach allows up to six energy sources (four of which are solar), three energy storage devices (two of which are thermal), and four types of load demands (electrical plus three levels of process heat). Figure 6 is a simplified power flow diagram for the general system. Again, the rectangular boxes are the independent variables which must be optimized, except in this figure each box may have multiple degrees of freedom up to the number in the lower right hand corner of each box. Thus, in the most general case eleven independent variables will have to be optimized.

The four types of solar collectors which can be evaluated individually or simultaneously include high and intermediate temperature configurations, a photovoltaic collector producing only electricity and a concentrating PV system producing electricity and thermal energy. These collectors are further compared to an on-site fossil-fueled turbine and off-site generated electricity. Three steam turbines (high, intermediate and low pressure) may also be a part of the power generating system.

Finally, high temperature and low temperature thermal storage along with electrical storage (batteries) can be included.

The optimization technique finds the combination of components which satisfies the multiple thermal/electric loads at the lowest life cycle energy cost. Hourly insolation and loads for a complete year are used in the analysis. At present the computer algorithms have been written and assembled, and test runs are now being made. Unfortunately, no sample results are available at this time.

It must be emphasized that such large computer analyses should never be considered as general purpose tools having nearly universal capabilities. To the contrary, the numerous assumptions required to develop this methodology tend to severely restrict its applicability. However, for a special set of solar total energy systems this tool should provide meaningful comparative performance figures, enabling the more promising concepts to be identified and analyzed more thoroughly by other techniques.

Cross-correlation analysis

This effort has attempted to determine if storage requirements can be easily predicted when time varying insolation and load demands are known. If reliable relationships can be found, simple rules of thumb may be used in place of large optimization techniques, at least in many applications.

To identify the potential merits of such an approach, an optimization code for photovoltaic systems (ref. 3) was exercised for a number of insolation and load demand states. Three synthetic insolation/load relations we used: first, rectangular power in and power out time histories were assumed; second, rectangular input was coupled to a sinusoidal output; and third,

a sinusoidal input was used with a rectangular output. In addition, two brief real sets of insolation/load time histories were analyzed.

For various time shifts between insolation and demand, the correlation function coefficient (i.e., the normalized cross-covariance function) was calculated and the optimum storage requirements for a stand-alone system were found. For this special case a good linear relationship between the correlation coefficient and storage size was found, and Figure 7 shows the combined results for all five insolation/load relations investigated. The normalized storage size is simply the storage capacity divided by the mean value of the load (amp-hours per kW for the battery storage system that was modeled).

The results are sufficiently promising to warrant additional analyses covering other solar collector and storage types utilizing load/demand time histories for extended periods (e.g., hourly data for a year). We hope to present any useful results found at a later date.

Conclusions

This brief paper has outlined the spectrum of solar energy system optimization techniques presently available or under development at Sandia, Albuquerque, with emphasis on thermal storage aspects. These tools are generally applications dependent but have yielded meaningful results for the solar energy programs for which they were intended. Additional results and further refinements are anticipated in order to provide continuing support of the respective programs.

References

1. Lukens, L. L., Perino, A. M., and Vandevender, S. G., "Preliminary Economic Analysis of Solar Irrigation Systems (SIS) for Selected Locations," Sandia Laboratories, SAND77-1403, November, 1977.
2. Dodd, H. M., Stewart, R. E. D., et al, "An Assessment of Mechanical Energy Storage for Solar Systems," Proceedings of the 12th Intersociety Energy Conversion Engineering Conference," August 28-September 2, 1977, Washington, DC, Vol. II, pp 1174-1180.
3. Linn, J. K., "Photovoltaic System Analysis Program - SOLCEL," SAND77-1268, August, 1977.

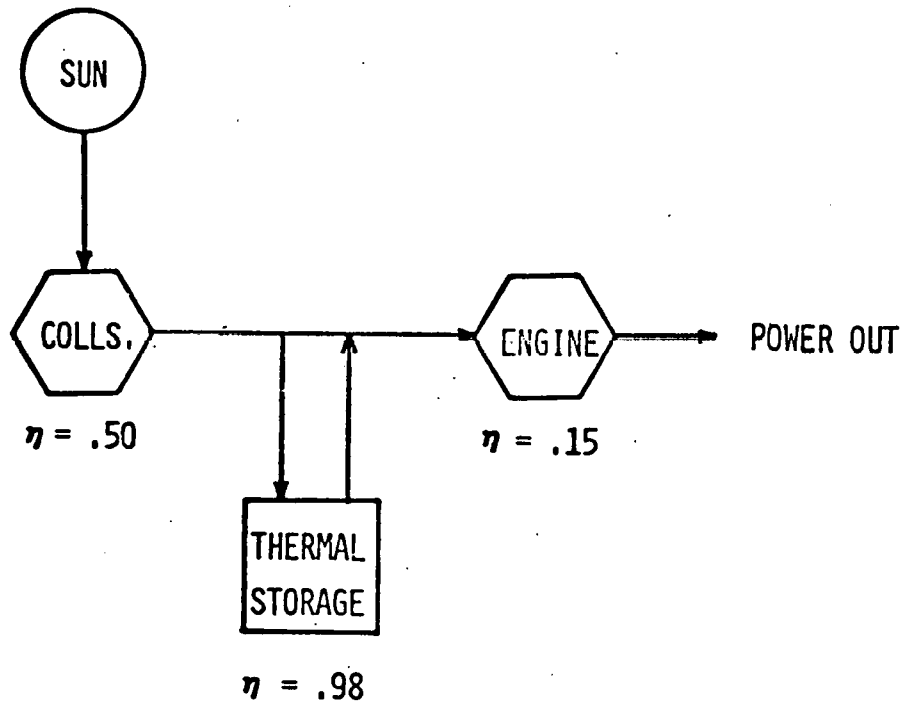

FIGURE 1. SOLAR IRRIGATION POWER FLOW

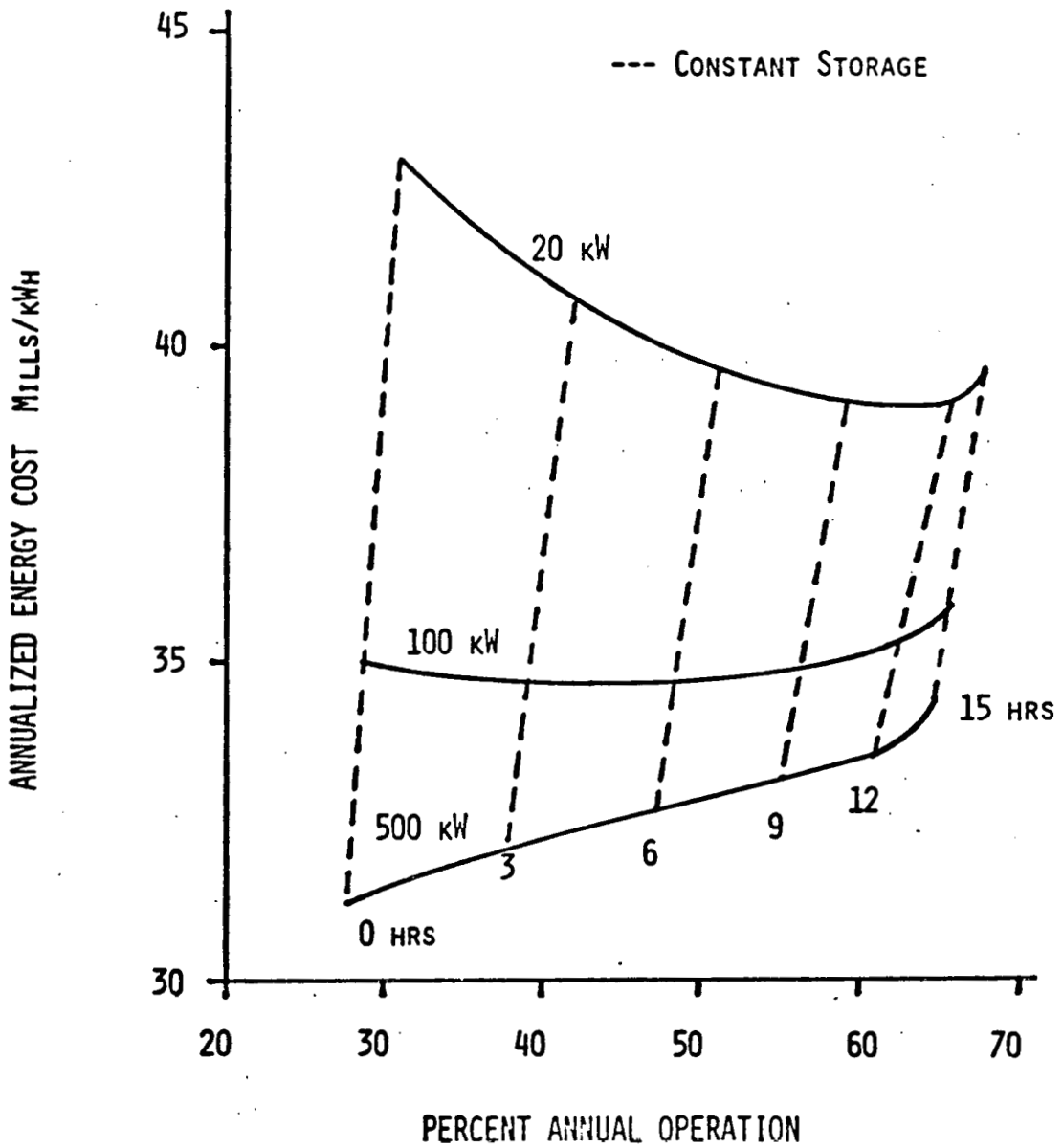

FIGURE 2. SOLAR IRRIGATION ENERGY COSTS AND LOAD FACTORS

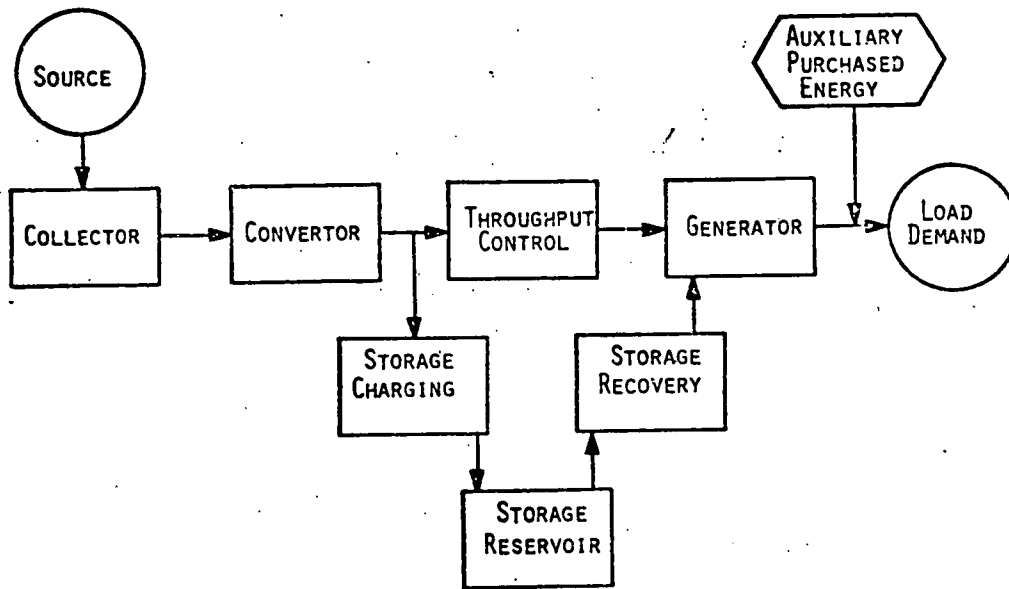

FIGURE 3. GENERALIZED SYSTEM LAYOUT AND ENERGY FLOW

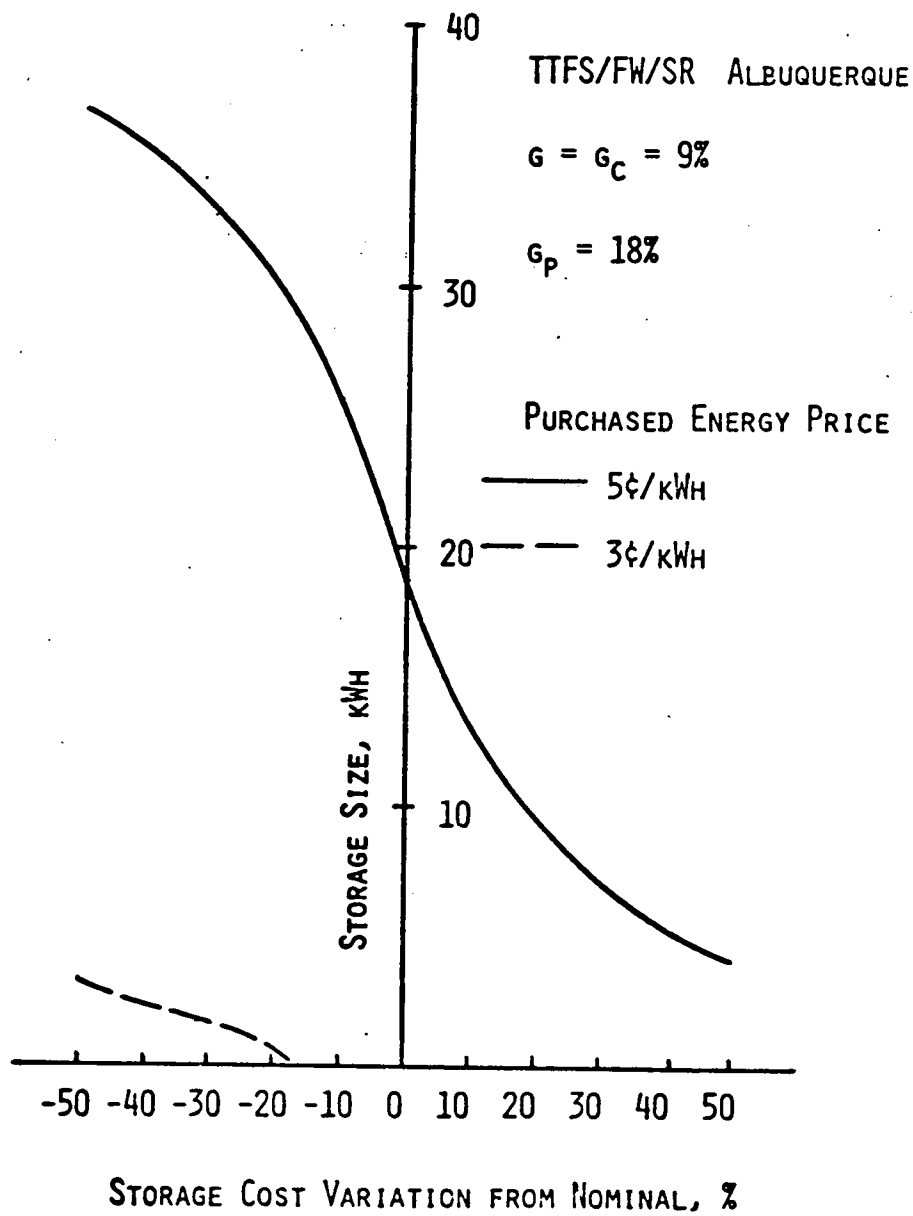

FIGURE 4. SENSITIVITY TO STORAGE COST VARIATIONS
EFFECT ON STORAGE SIZING

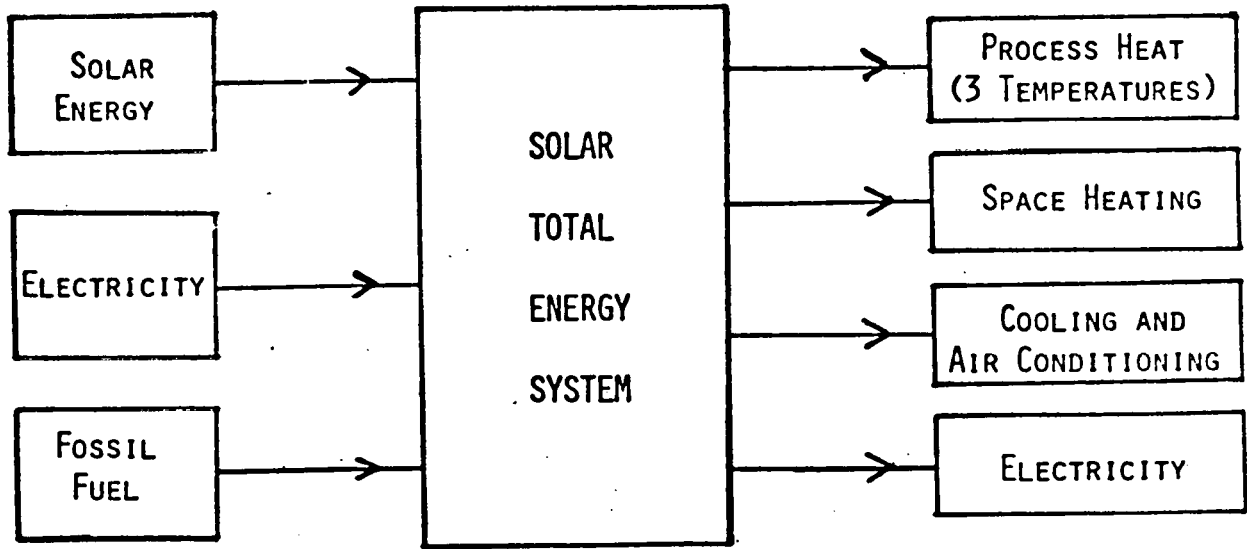

FIGURE 5. STES ENERGY SOURCES AND DEMANDS

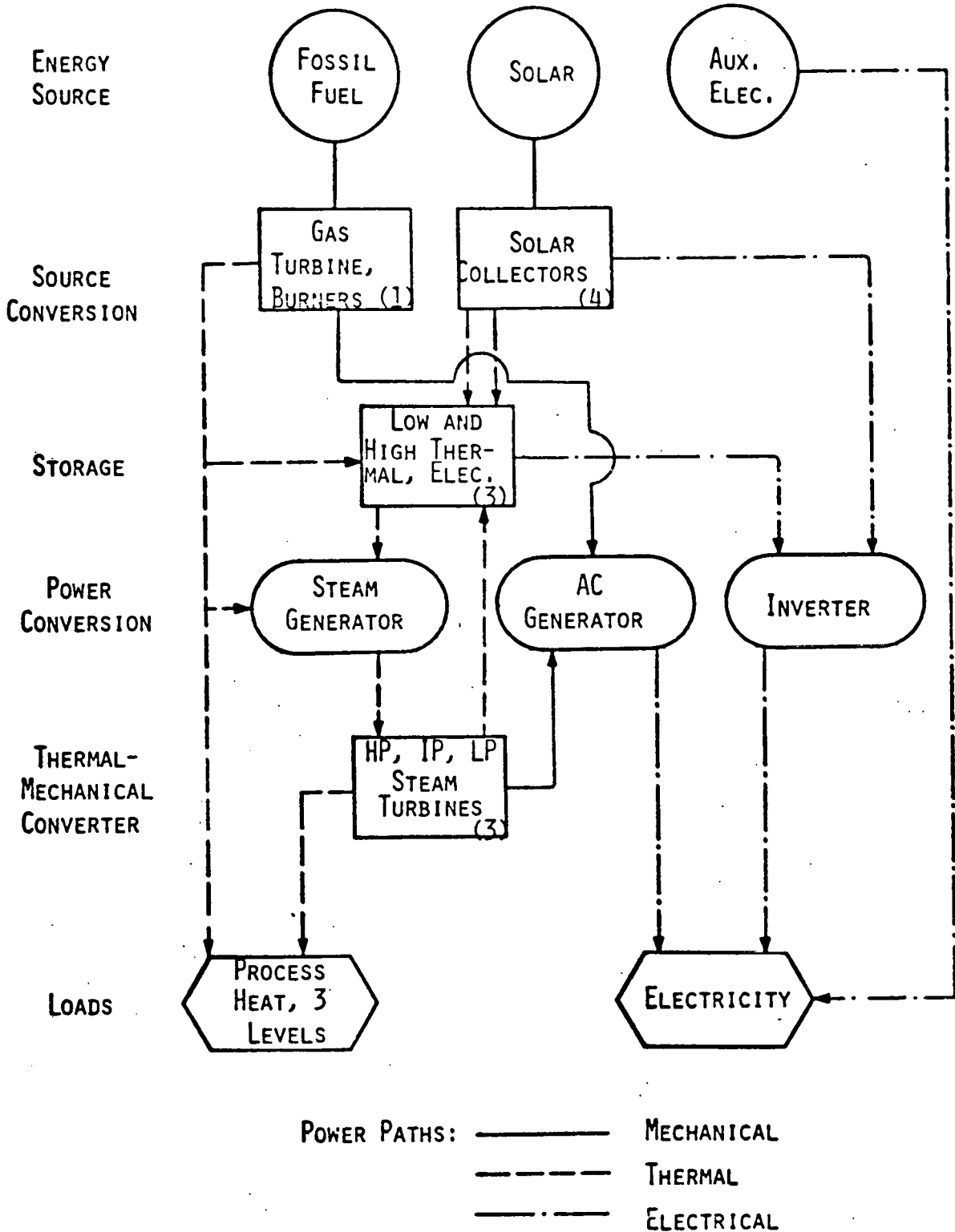

FIGURE 6. SOLAR TOTAL-ENERGY POWER FLOW LOGIC

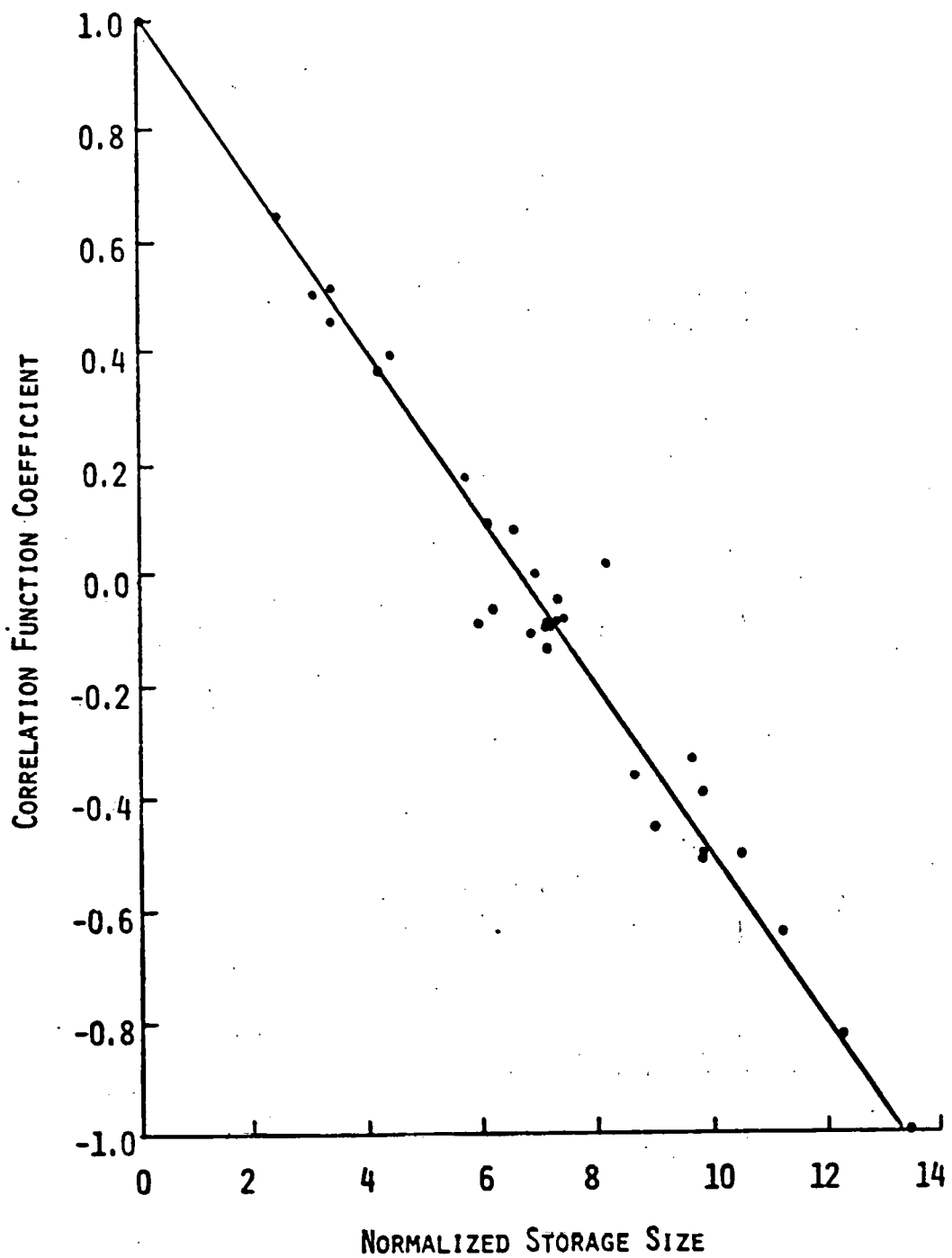

FIGURE 7. RELATIONSHIP BETWEEN SOURCE/LOAD CORRELATION AND OPTIMUM STORAGE SIZE (3 SYNTHETIC, 2 REAL DATA SETS).

Paper 2-6

THE VALUE OF SEASONAL STORAGE OF SOLAR ENERGY

J. J. Iannucci
Systems Studies Division III 8326
Sandia Laboratories, Livermore

February 1978

I. GENERAL COMMENTS AND INTRODUCTION

This paper is aimed at answering the questions:

1. How much storage is optimal for a given system?
2. How does hybridization affect storage requirements?
3. What is the overall value of storage to solar thermal electric plants?

To answer these questions, we have examined how seasonal storage in particular should be utilized depending on the goals of a utility and the insolation available. Although some of the results discussed here are specific to chemical storage for solar thermal electric plants, many of their implications are believed to be valid for other forms of storage also. It is to be emphasized that the approach to the problem has been two-pronged. The bulk of this work has been accomplished with detailed computer simulations of an operating solar plant. But to give further insight into the value of storage in these applications, analytical approximations were also used; these have been clearly labeled as such throughout this paper.

In essence, it is found that providing 100% of any load from solar power places severe requirements on component sizing. Relaxing the 100% requirement to 90% or so allows for greatly reduced component sizings and higher utilization factors for these components. Discarding solar energy to allow higher utilization factors on solar components is also found to be a good idea. The point of quickly diminishing returns on storage size for baseload applications is found to fall in the 10-30-hour range over a wide variation in solar plant geographical locations. Further, the scatter in solar plant component sizes is investigated over 12 years of insolation data for one location. The field sizes vary by only 10-20%, but storage requirement ranges over a factor of two.

II. STORAGE OF SOLAR ENERGY: HYBRID CENTRAL SOLAR/FOSSIL ELECTRICAL GENERATION

A. Objectives

The objective of this study is to examine the "worth" of storage to a stand-alone solar electric plant. A stand-alone or grid-independent plant is one which must provide the entire load for an electrically isolated community. This stand-alone plant may be either a pure solar plant or a solar/fossil hybrid. The optimal size and worth of storage for such a specific type of plant is only one measure of the importance of storage to solar electric plants in general. This paper discusses the methodology, presents preliminary results and offers some tentative conclusions, not only about seasonal storage, but also about storage in general.

B. Method of Analysis, Data and Goals

A computer model simulation of a solar plant was developed. The model includes a fossil fuel backup system which can be turned on as required to supply part or all of a possibly time-varying load. A crucial part of this model is the solar power dispatching algorithm which allows for symbiotic coupling between the solar and fossil parts of this hybrid stand-alone plant. The model steps through an entire year, hour-by-hour, and examines both insolation (raw solar power availability) and load to determine how the load will be satisfied and whether any energy can be put into or removed from storage. The figure of merit is the busbar energy cost in the first year of operation of such a plant in mils per kilowatt-hour. The solar plant model

is linked to an optimization routine which varies plant component sizes (e.g., storage size, maximum storage charge rate, number of mirrors, receiver size) against the amount of fossil fuel burned to yield an optimum cost solution. Naturally, as the power handling and energy storage components increase in size, they increase in cost. Thus, the optimizer selects the proper amount of storage required to make the hybrid solar/fossil plant produce electricity at the lowest possible cost to the consumer.

This optimization technique provides a tool for examining various solar energy storage systems (thermal, latent and chemical) for diverse applications (daily, weekly or seasonal storage). Chemical modes and extended (seasonal) storage were the main thrust of this study. In particular, we examined an $\text{SO}_2/\text{SO}_3/\text{O}_2$ system which stores the oxygen generated while charging storage. The fossil fuel cost plays a pivotal part in determining the percent of solar involvement in such a solar/fossil hybrid plant and, thus, the fuel escalation rate was left as a parameter for which a reasonable spectrum was examined.

Although we have made what we believe to be reasonable estimates for solar/storage component costs, a sensitivity study has been initiated regarding those costs. Further, the optimum sizes of such components are known to be sensitive to insolation levels and availability and to load requirements. Preliminary results of these sensitivity studies are offered herein.

The goal, then, is to generate data such as those shown conceptually in Figure 1. Here the busbar energy costs have been normalized to the 0% solar (100% fossil) costs. The solid line represents the cost of the least expensive (optimal) way to satisfy a given percent of the total electrical energy (integrated load) from the solar plant. Beyond a specific percent solar, it becomes economical (and even further to the right, imperative) to buy storage. Thus, the point, S, divides the optimal solutions into two parts: one which refuses storage and one which requests

it. The lowest cost of all represents the optimal economic design point. Any solution whose normalized cost ≤ 1 is considered an economical solar solution. The 100% solar design point is the least expensive way to provide all of the power from the sun.

C. Sample Results and Preliminary Conclusions

Table I shows a few of the optimal solutions for various fixed numbers of mirrors (i.e., solar multiples--a solar multiple of one is roughly just enough mirrors to provide 100 MW of electricity at noon on a cloudless June 21). These results are based on 7.5% fuel escalation (2.5% above a capital escalation rate of 5.0%) between 1976 and 2015, the first year of operation. Relative electricity costs (normalized as in Figure 1) are given for heliostat costs of \$60 per square meter and \$120 per square meter. Tables II and III summarize results for two years.

Results show that the optimal solutions for this stand-alone system do not store energy for extended periods of time (i.e., months), but rather use chemical storage primarily for evening and night loads. Yet plants with less than ten hours of storage can provide over 90% of the load from the sun. The reasons for this surprising result lie in the load and insolation data used. The rather uniform daily load fluctuations (the night loads are low and the daytime loads match the insolation somewhat) coupled to the excellent weather at Inyokern have emphasized the daily storage aspects of this plant.

In order to understand more fully the results and implications of the previous work (especially for large solar impacts), more detailed computational work was carried out. Two different modes of plant optimization were pursued corresponding to two (at times) diverse goals.

1. The first mode was to maximize the solar output of the plant with economic considerations taken to be important but secondary to that primary goal. Figure 2 shows the solar

output (as a percent of the fixed, total energy requirements of the load) as a function of the mirror area (solar multiple) in a nominally 100 MWe plant. The solar multiple which could provide just enough energy to satisfy 100% of the load from the sun is seen to be 2.63. This is called the critical solar multiple. Figure 3 shows the hours of storage capacity (at full plant output) which the plants defined by Figure 2 require.

The extreme peaking of the storage requirement near the critical solar multiple is one indication that maximization of solar penetration at all costs may cause some unusual design and cost problems. Mirror fields up to a solar multiple of 2 (76% of the critical solar multiple) have modest storage requirements (less than 10 hours at full plant output); but in the range of 2-3.5 solar multiple, storage requirements are dramatically larger. Electricity costs also rise near the critical solar multiple and reach a local minimum once the storage requirements can be reduced near a solar multiple of 3-3.5. The costs peak sharply near the critical solar multiple, chiefly due to the storage capacity requirement increase.

Beyond the critical solar multiple, economic considerations become more important since 100% solar can be accomplished in many ways; while at and below the critical solar multiple, components were sized such that no energy can be discarded at all. The ability to discard energy in many ways at these larger solar multiples allows economic considerations to come into play. Indeed, storage is traded off for more mirrors yielding a lower cost result. Table I shows this minimum-cost 100% solar system to have a minimum near a solar multiple of 3.5 for mirrors costing $\$60/M^2$ and near 3.0 for mirrors costing $\$120/M^2$. For this reason, should one want to provide 100% of some load with solar, the field must be oversized ($SM > SM$ critical) unless mirrors are very expensive. Of course, in this latter case, the plant might never be built in the first place.

2. The second mode of plant optimization was to minimize the busbar energy cost (from pure economic considerations) with the secondary goal of emphasizing solar involvement. The solar involvement was assured by picking a moderately high backup fuel escalation rate of 7.5% per year between now and the first year of operation. Figure 4 shows the percent solar versus solar multiple for this economic optimization. The curve is very close to that in Figure 2 except that it is somewhat lower throughout. Instead of reaching 100% solar at any point, it is slowly and asymptotically approaching it. Note that a solar multiple of 2.5 gives better than 90% solar. Figure 5 shows the greatly reduced storage requirements for this system. The storage requirement still peaks near the critical solar multiple, but it is nowhere near as sharply peaked and the value is 4% of the peak shown in Figure 3. These relaxed storage requirements also yield much lower cost solutions, albeit with less than 100% solar production. The busbar energy cost at the critical solar multiple for this hybrid (providing better than 90% of the load) is less than half that of the pure solar plant.

This is a classic example of how discarding energy in a solar plant can make for a much more economical solution. In general, for any plant which can purchase backup fuel or electricity at reasonable cost, it is good economic policy to discard sizable amounts of solar energy. This is due to the variable nature of solar energy. Building components big enough to accept all the available solar energy at all times of the day and year tends to have systems with uneconomic (low) utilization factors. While these results are not universally applicable due to the specific nature of the load and use of superior insolation from Inyokern, they are representative of results for a broad class of applications and locations. The conclusion then is that if one allows hybridization down to a level of 90% solar (10% fossil) storage capacities can be greatly reduced with appreciable cost reductions from 100% solar solutions.

III. ANALYTICAL APPROXIMATION: STUDY OF THE VALUE OF ENERGY STORAGE

A. General Comments

The results discussed above were based on specific insolation and load data and a number of assumptions related to subsystem cost and performance. It is reasonable to speculate whether there is some general truth in the answers or whether the results are dependent on the specific load, insolation, performance and cost assumptions. In order to more clearly and directly investigate performance tendencies than is possible with detailed simulations, we have initiated a parallel effort to examine storage system performance and utilization using a simplified analytic model rather than the detailed simulation. Some initial results are discussed below.

B. Hours of Storage-Definition

A general point of confusion regarding storage is the definition of an hour of storage. The definition used in these studies is that one hour of storage is the equivalent of the amount of thermal (or chemical) energy which (upon discharge from storage and through a turbine) could produce the rated electrical capacity of that turbine for one hour. Thus, the number of hours of storage available at any time is in no way a function of:

1. How long that energy has been in storage.
2. How long it took to charge storage.
3. How long it has been since storage was last charged or discharged.
4. Whether the next discharge will be at full capacity or not.
5. How many hours one could satisfy some time-varying load.

Thus, as is often the case for variable load simulations, 10 hours of storage could provide the load for the next 20 hours if that load were low enough. Likewise, 8 hours of storage may have been charged many weeks previous and only now discharged.

C. Difference between the Energy in Storage and the Energy from Storage

The energy in storage (EIS) is just the hours of storage as defined above. The energy from storage (EFS) in any given time period is just the difference (or differential) between the energies in storage before and after that time period.

$$EFS(J) = EIS(J - 1) - EIS(J)$$

This is similar to saying that the energy from storage is proportional to the time derivative of the energy in storage.

In essence, for cases which have true seasonal-type storage, the energy in storage can be written as the sum of several cyclic terms.

$$EIS(t) = C_0 + C_1(t) + C_2(t) + \dots + C_n(t)$$

For the sake of specificity, we have taken the time-varying terms to correspond to daily, weekly and annual "portions" of storage. (These are conceptual "portions" only, meaning the part of a large storage unit which can be thought of as satisfying daily, weekly or seasonal needs.) Ignoring phase factors, since the frequencies are so diverse, and using sine functions as a first approximation, we can take

$$EIS(t) = A(1 + \sin \omega_1 t) + B(1 + \sin \omega_2 t) + C(1 + \sin \omega_3 t)$$

where A, B and C correspond to half of the energy capacities of

the seasonal, weekly and diurnal storage components and ω_1 , ω_2 , ω_3 are the frequencies. Figures 6-8 show an example of such a function where $A = 125$ hours, $B = 2.5$ hours and $C = 5$ hours. For true seasonal storage, $A \gg B + C$, but this does not mean that most of the energy supplied by the plant comes from storage in the seasonal sense. In fact,

$$EFS(t) \propto \left(\frac{dEIS}{dt} \right) = A\omega_1 \cos \omega_1 t + B\omega_2 \cos \omega_2 t + C\omega_3 \cos \omega_3 t$$

and we see that the energy from storage may well be dominated by daily storage if $C\omega_3 \gg A\omega_1 + B\omega_2$. This is, indeed, the case even for simulations which appear to be storing seasonally. Figures 9-11 show these derivatives (representing the energy from storage) for the same function as in Figures 6-8. (Although sine functions were used in the above analysis, any differentiable cyclic functions would yield the same general result.)

D. Value and Utilization of Various Storage Capacities, Daily through Seasonal

If we assume that the value of a given "part" of storage is in some way proportional to the number of times it is used, then we have an interesting result. The largest part of the storage capacity is for seasonal storage ($A \gg B + C$), but that is the part which is least used: That is the reason that, given a choice of building more storage capacity or burning more fossil fuel, any optimizer tries to stop short of seasonal storage even beyond the critical solar multiple. In this regard, a parameter study was performed to measure the energy from storage for plants that were optimized, but had their storage capacity held fixed. One expects the total energy from (or through) storage to be a monotonically increasing function of hours of storage but with an ever decreasing slope. This is, indeed, the case and the slope of that curve is exactly the frequency with which a given "part" of storage is used. These results have been confirmed by

examining simplified load and insolation models and calculating the exact energy from storage under those conditions. Effects included are differing night and day loads and variable lengths of night.

This point is best illustrated by Figure 12. Here we see the energy from storage (i.e., not directly from the receiver) for an entire year versus the number of hours of storage. The load has been idealized to be constant and the insolation bimodal-- either at some set level during the day or zero at night. The length of night has been assumed to vary sinusoidally during the year from 8 to 16 hours (as it does very nearly in reality). The initial linear part of this curve has a slope of 365 as the first 8 hours of storage are useful every night of the year. Then, the slope reduces to zero over the region of 8-16 hours of storage. This latter value corresponds to the maximum amount of storage ever needed on the longest night of winter. When computer simulations using real insolation and load curves are used to generate this same plot, the result is almost identical. The main difference is that for seasonal storage cases, the slope reduces to one (rather than zero) beyond 16 hours and only goes to zero for much larger storage sizes. The slope of one means that this "part" of storage is used only once in 365 days (i.e., seasonally).

This type of information on the utility of storage coupled to a backup fuel cost (or a competitive solar proposal) may lead to being able to size storage correctly without detailed dispatching considerations, but rather on a more global economic basis.

E. Balance of Marginal Value of Energy-Handling Components

For any credible fuel escalation rate there occurs a limit on the economical worth of providing any more of the load from

the sun. At this marginal value point we have discovered both mathematically and computationally that the marginal value of energy for all components in the plant are constants and equal to the marginal cost of fossil fuel backup energy. Of course, this balance holds only for components whose function is energy related. This general result may be of great interest to those who wish to develop "rules of thumb" for storage sizing and utilization.

IV. COMPUTATIONAL SIMULATION OF THE VALUE OF STORAGE AT VARYING LOCALITIES AND YEARS

The most recent segment of this work has been the examination of the value of storage with insolation data for diverse geographical locations. To date, Albuquerque, Miami, New York and Madison (Wisconsin) have been used. To avoid the clutter of load dissimilarities between these locations, only baseload (constant load) cases have been run. Most variable loads (as were done for Inyokern, above) will yield the same general results but perhaps will require even less storage.

As was expected, storage requirements and mirror field sizes differ greatly between these locations. As one measure of this, Table IV shows the critical solar multiples and the storage required at these solar multiples to satisfy 100% of a baseload by solar power. Albuquerque clearly has the most sunshine as its critical solar multiple is the lowest by far. However, Miami must have more seasonally level solar energy since its storage requirements are lowest.

Figures 13 and 14 show the percent of this baseload which could be satisfied by solar in Albuquerque versus hours of storage (over three orders of magnitude). This is shown for several mirror field sizes clustered about and including the critical solar multiple. Figure 14 shows the same data plotted on an expanded scale. Here, the point is shown clearly that a point of quickly diminishing returns is reached at about 20 hours of storage. At storage capacities beyond this, there is little performance to be gained at the lower field sizes. At larger

field sizes, another few percent solar can be generated but only at the expense of 10-40 times the storage capacity. The maximum storage that this baseload plant could ever use is 845 hours, the value required at the critical solar multiple and 100% solar. As before, if 100% solar is required, the best way for this to be accomplished is by oversizing the field slightly in order to reduce storage requirements dramatically. These same general tendencies are shown in Figures 15, 16 and 17 for Miami, Madison and New York, respectively.

To get a first measure of the yearly differences in insolation and its impact on storage requirements, 12 years of data (1953-1964 inclusive) have been examined for Albuquerque. The critical field size ranges from a low of 4.69 in 1953 to a high of 5.51 in 1957. The critical field storage requirements range from a low of 594 hours in 1963 to a high of 1143 hours in 1957. Table V summarizes all of these critical field size results as well as the yearly totals of direct normal insolation.

CONCEPTUAL PLOT OF
COST NORMALIZED TO 100% COMBUSTION TURBINE SOLUTION

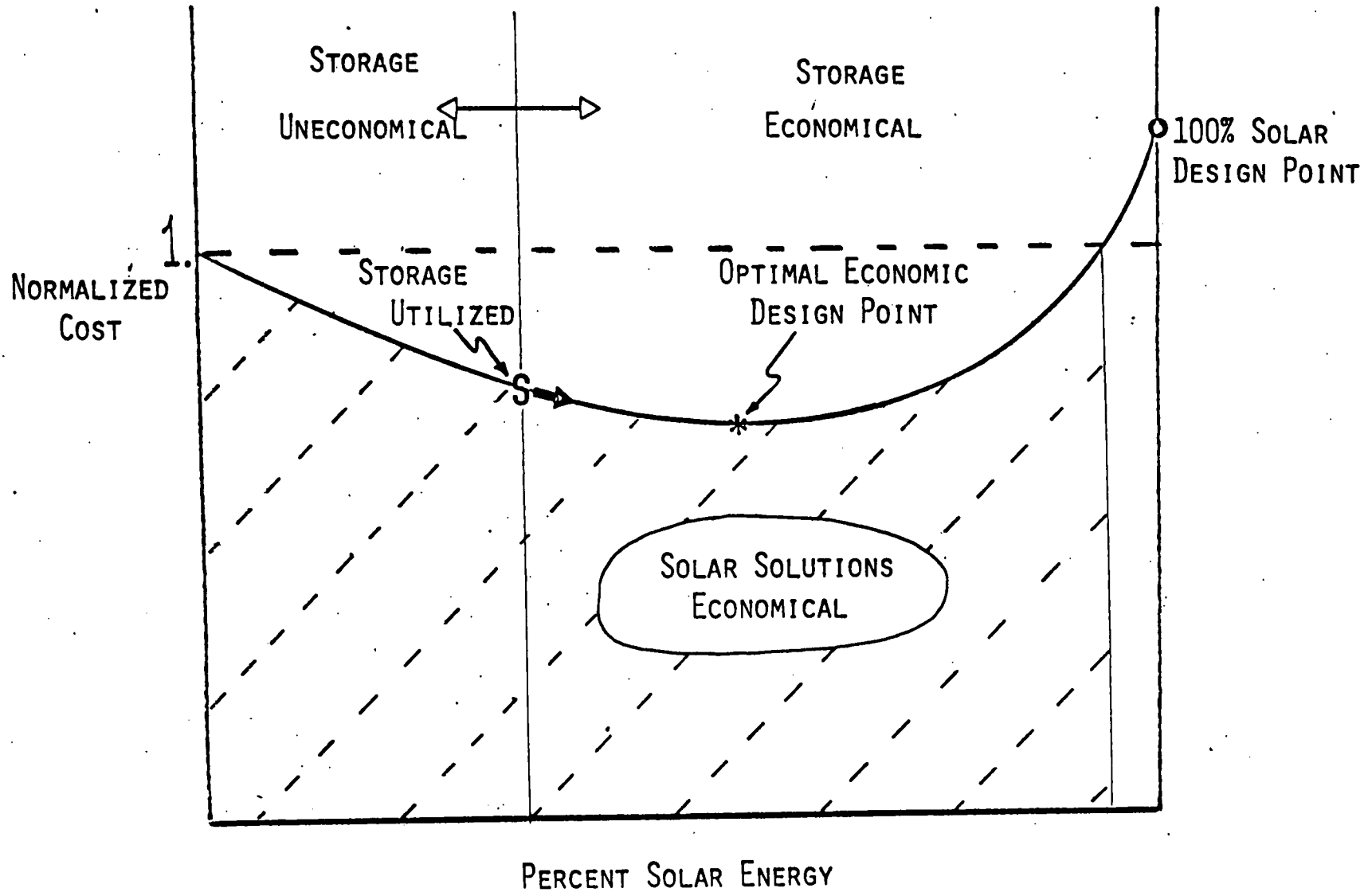

FIGURE 1

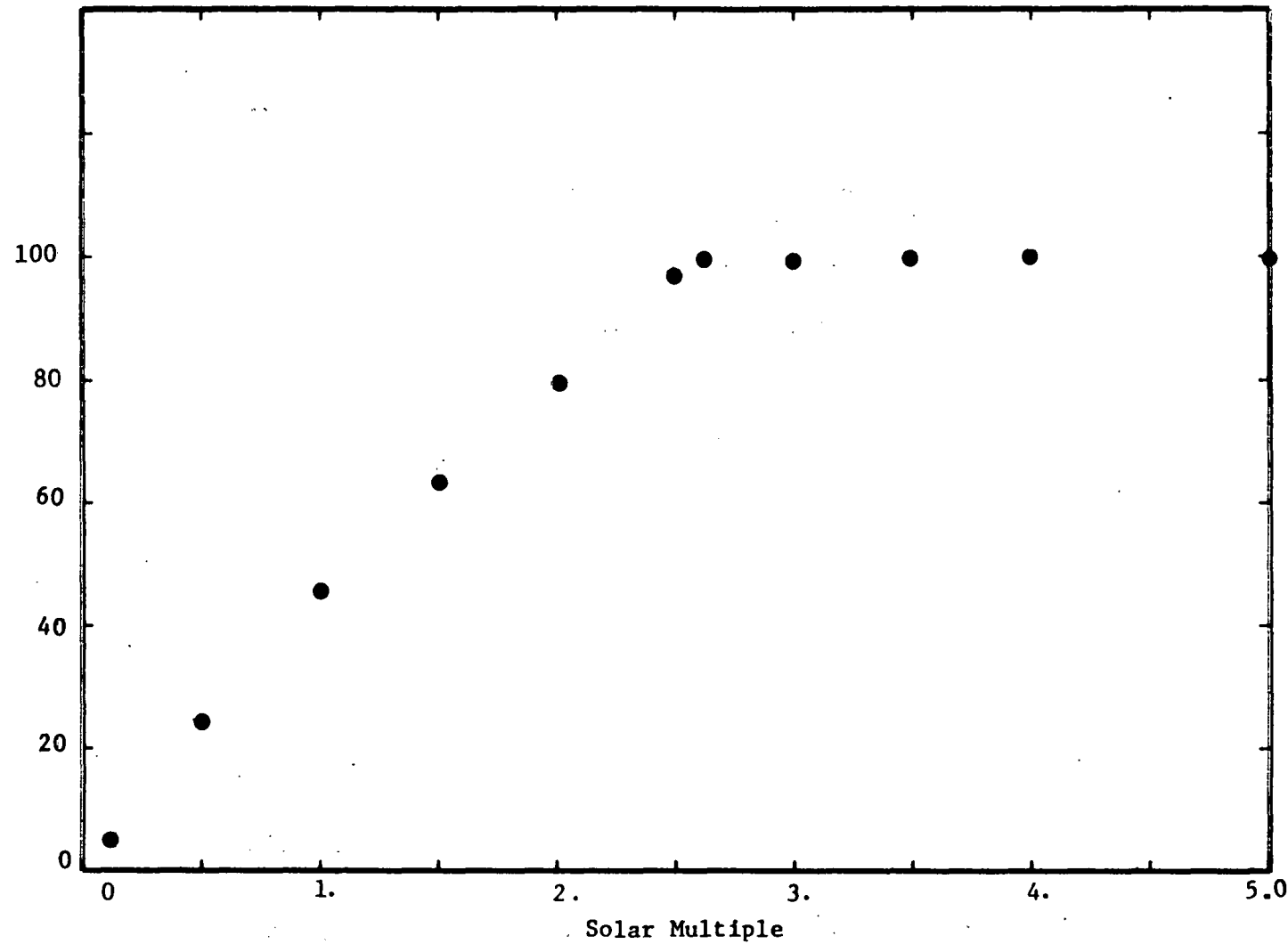

Figure 2. Solar output maximized. Note sub-linear dependence of percent solar on the solar multiple as a larger and larger fraction of the energy comes through storage with its parasitic power losses.

228

at SM = 2.63

Normalized
Cost = .640

Percent
Solar = 100.

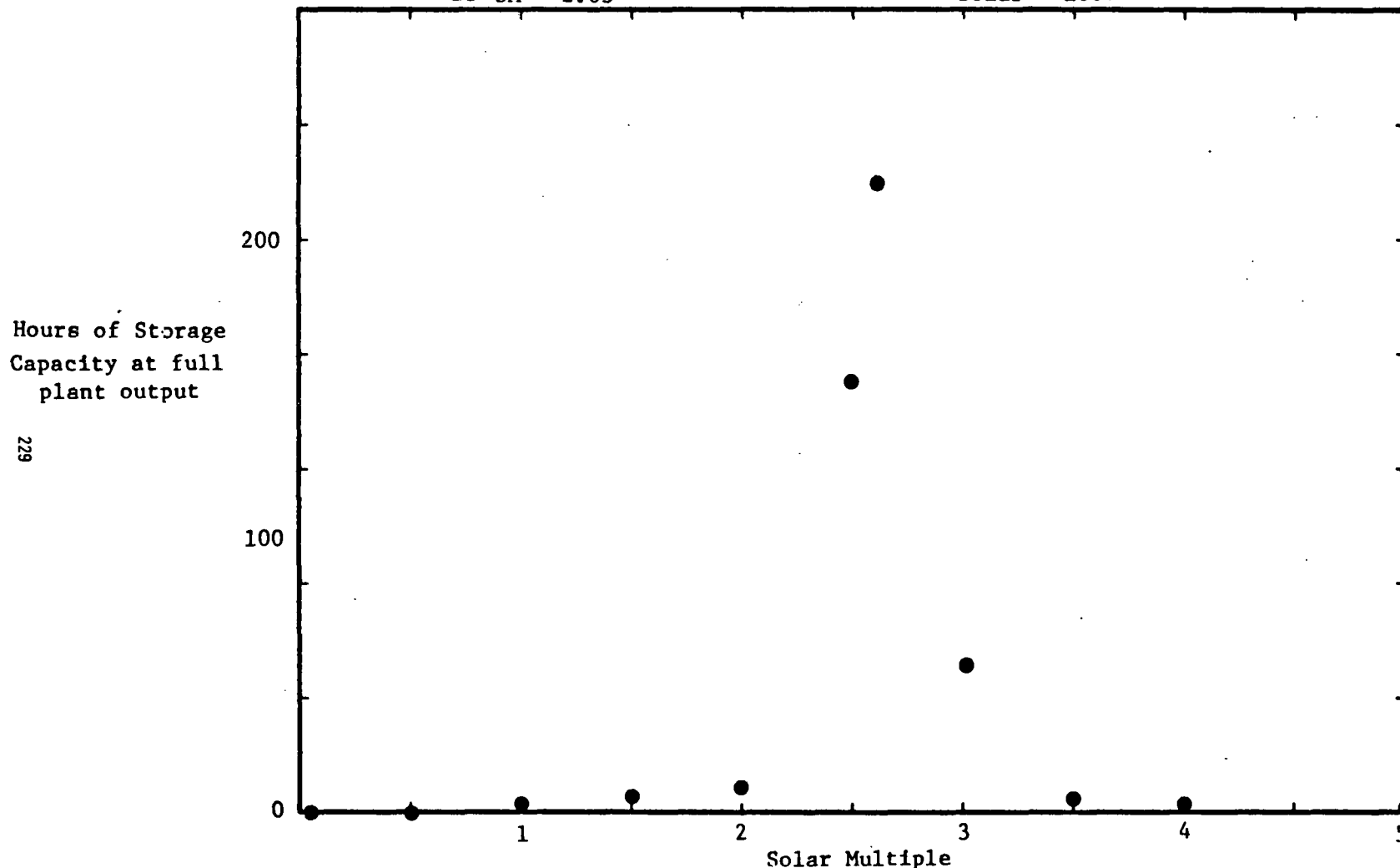

Figure 3. Solar output maximized. The solutions with a solar multiple less than 2.63 provide less than 100% solar due to insufficient mirrors. Those above the critical solar multiple are 100% solar solutions and discard energy due to the mirror surplus. At the critical solar multiple no energy is discarded and 100% of the load is satisfied by solar. Note that oversizing the mirror field (beyond the critical solar multiple of 2.63) relaxes the storage requirements considerably. The larger solar multiple solutions are also more economical than that at the critical solar multiple.

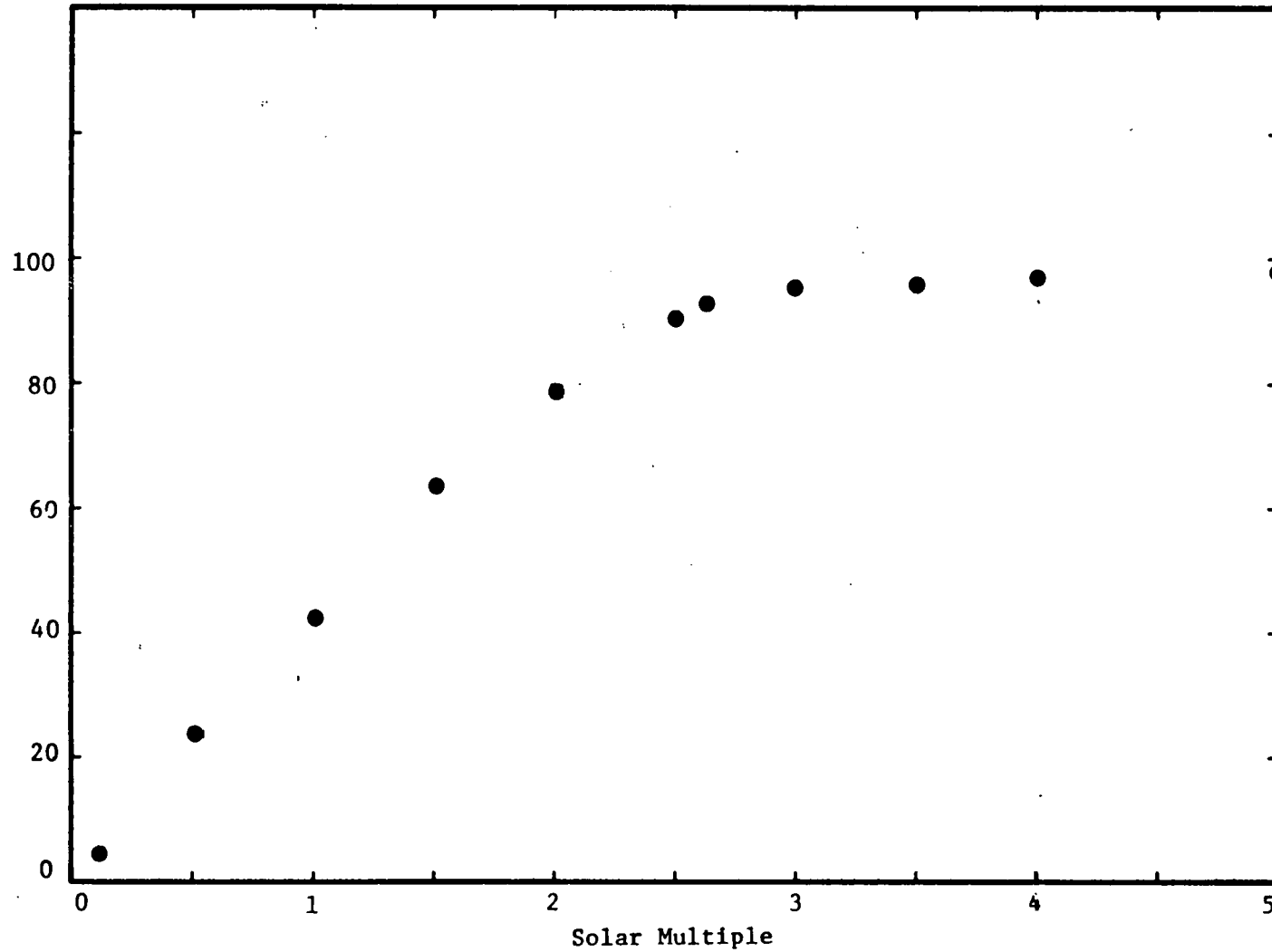

Figure 4. Plant designed for minimum busbar energy cost. Hybrid solutions such as this one will always provide somewhat less energy from the sun, but at potentially large cost benefits. The hybrid's busbar energy cost at a solar multiple of 2.63 is less than half that of the solar plant.

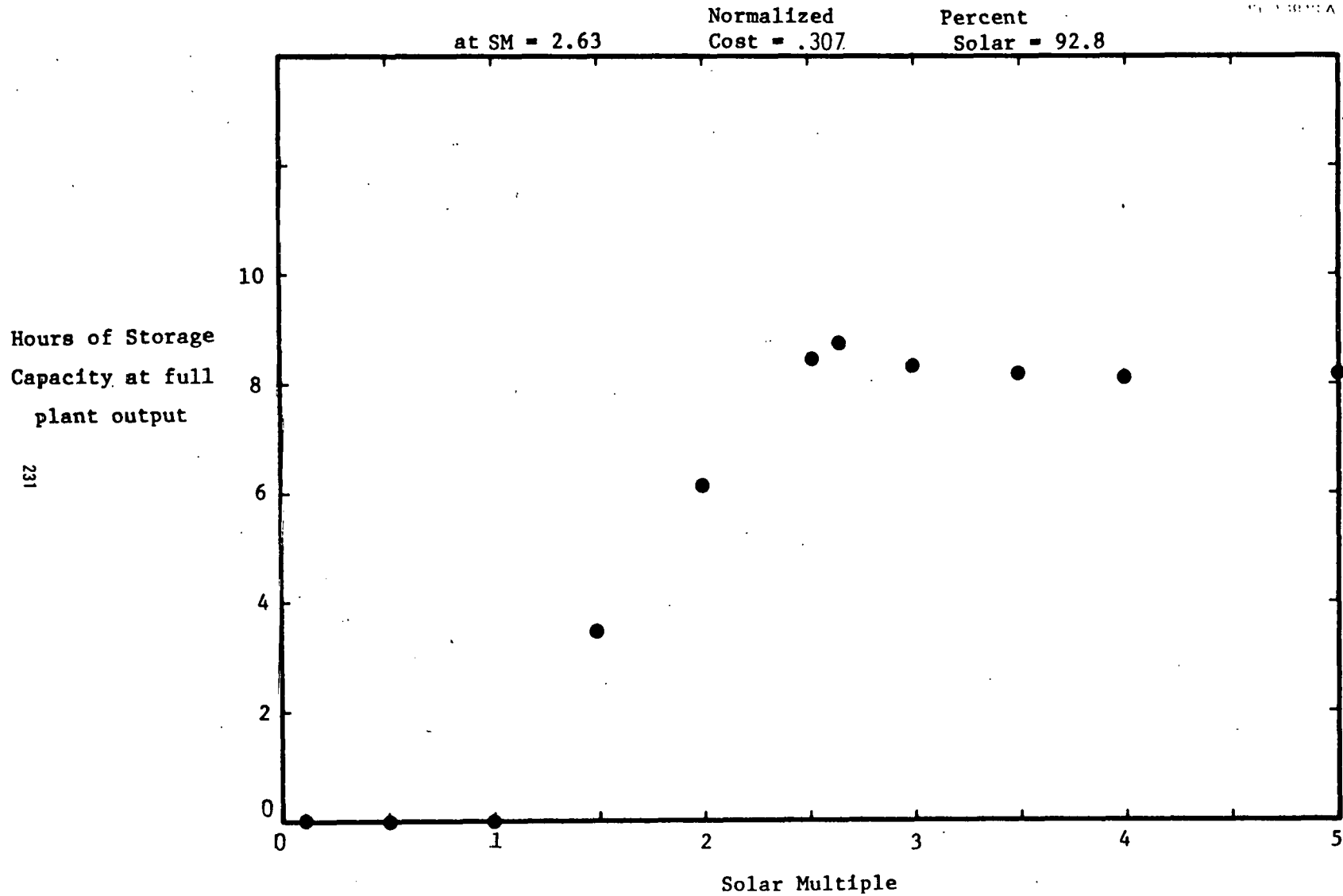

Figure 5. Plant designed for minimum busbar energy cost. While the amount of storage still peaks near the critical solar multiple of 2.63, note the dramatic change in storage requirement for a small amount of hybridization .

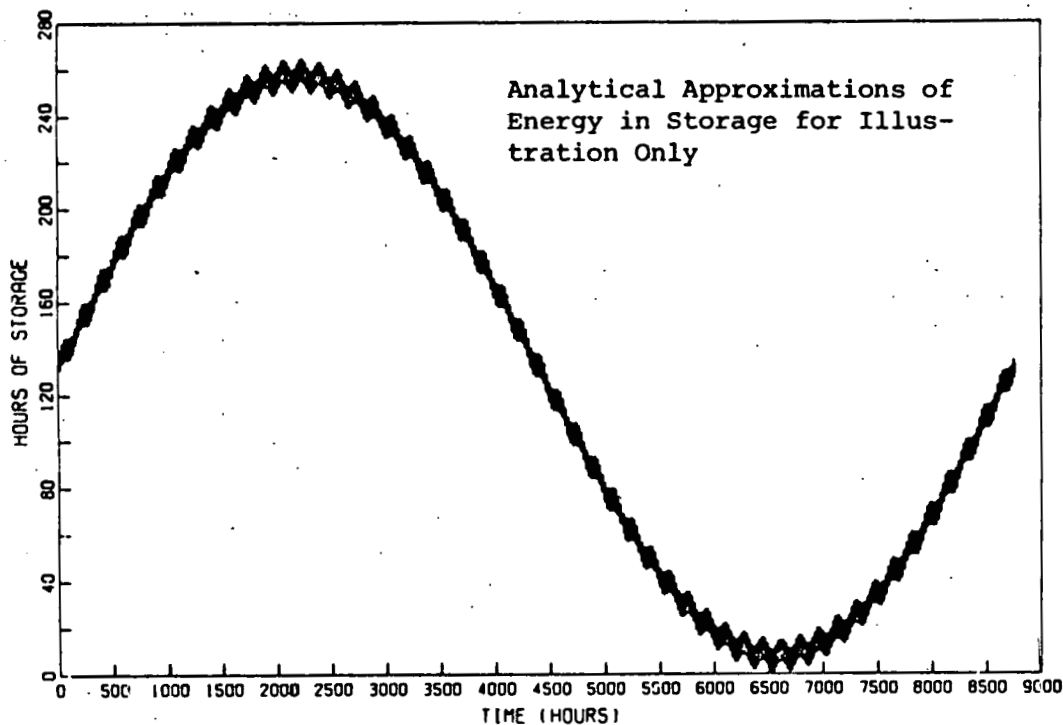

Figure 6. Although sine functions were chosen for simplicity, any periodic function could be used to represent the seasonal amount of energy in storage. The breadth in this curve is due to the lower amplitude, higher frequency components corresponding to daily and weekly variations of the energy in storage. Here we have taken the seasonal component of storage to be 250 hours, weekly 5 hours, and daily 10 hours. This plot covers an entire year (beginning in the summer) while figure 7 and 8 plot the same function for periods of roughly a month and a week.

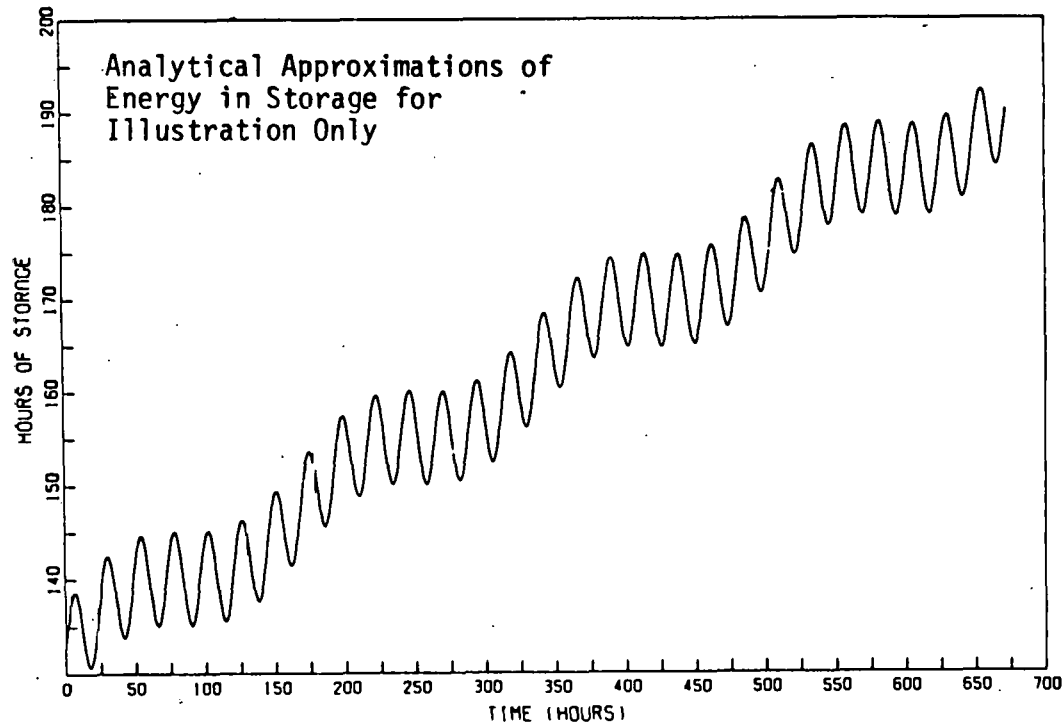

Figure 7. This is again the idealized energy in storage for a plant which stores "seasonally", but covering only the first month of this year (perhaps July). This was a favorable solar month since there is more energy in storage at the end of the month than at the beginning, despite the daily and weekly oscillations. The four weekly cycles are now clearly visible. These might be due to weekend load reductions.

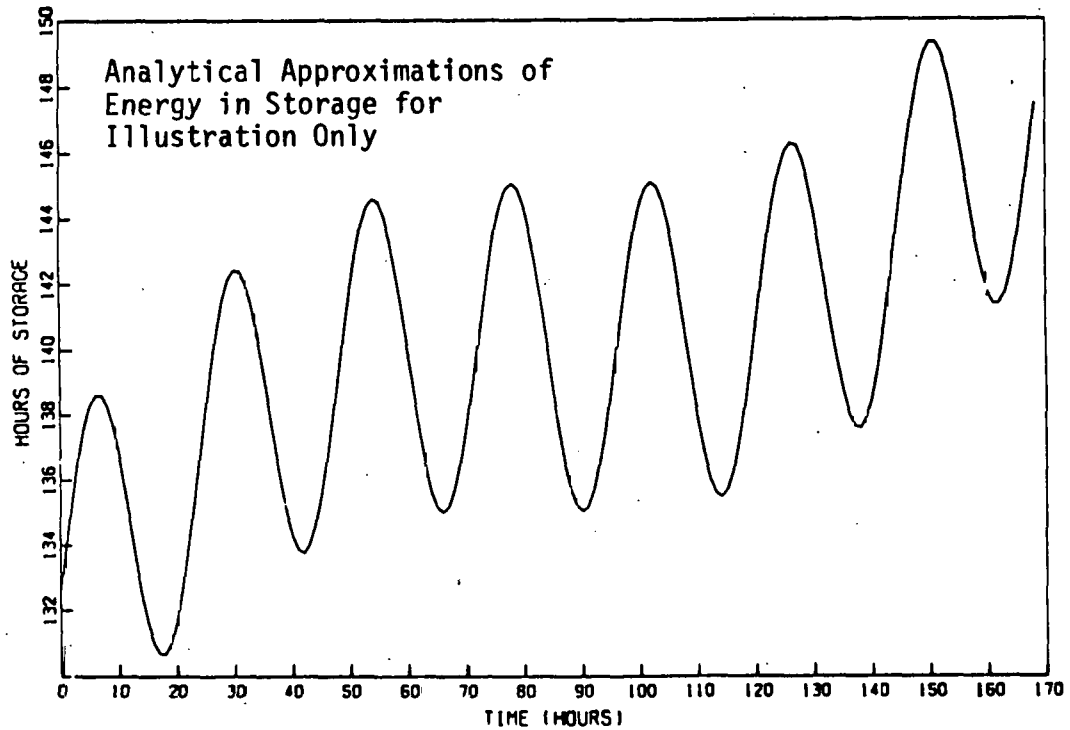

Figure 8. Once again the energy in storage but for now for the first week in July. The seasonal trend is discernable on this scale and the weekly variation is clearly seen. The main feature is the daily variation of energy in storage to provide the nightly loads.

Analytical Approximations of Energy in Storage for Illustration Only

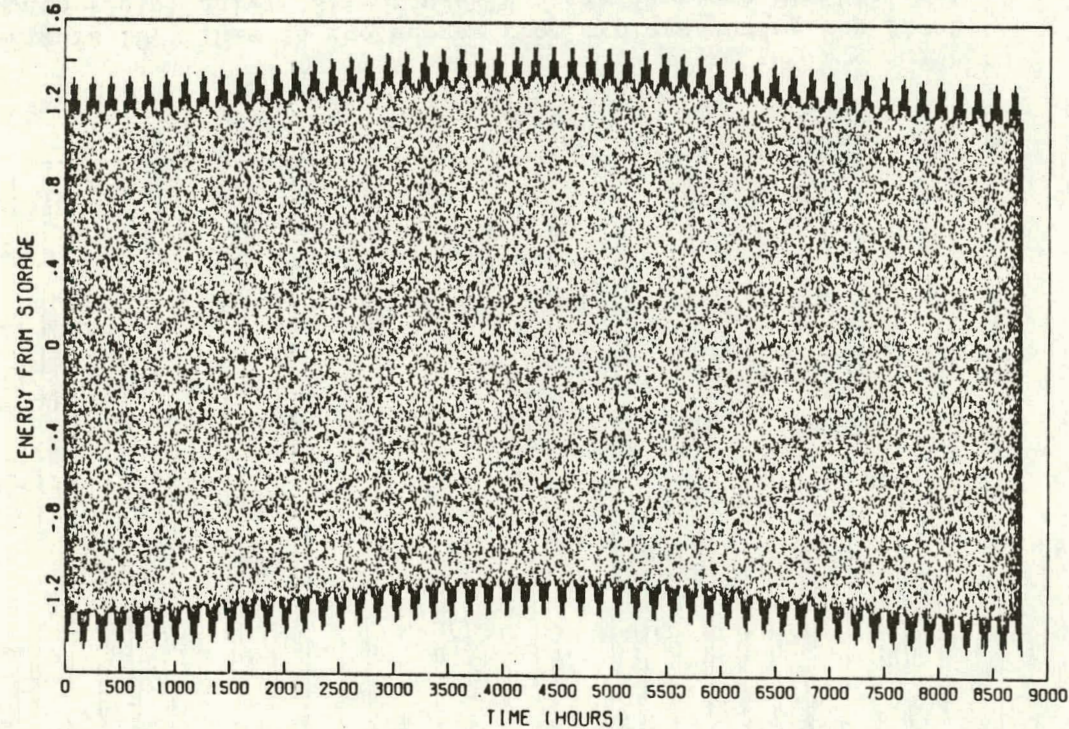

Figure 9. This plot may at first seem too broad to have any meaning, quite the opposite is true. It would be expected to be broad since many different discharge (energy from storage >0) and charge (energy from storage <0) rates are used during a year (or in fact during any one day). The most interesting feature is that the energy from storage does not peak significantly in the winter as one might expect, this is since the derivative is everywhere dominated by the highest frequency term, the daily variations.

Analytical Approximations of Energy in Storage for Illustration Only

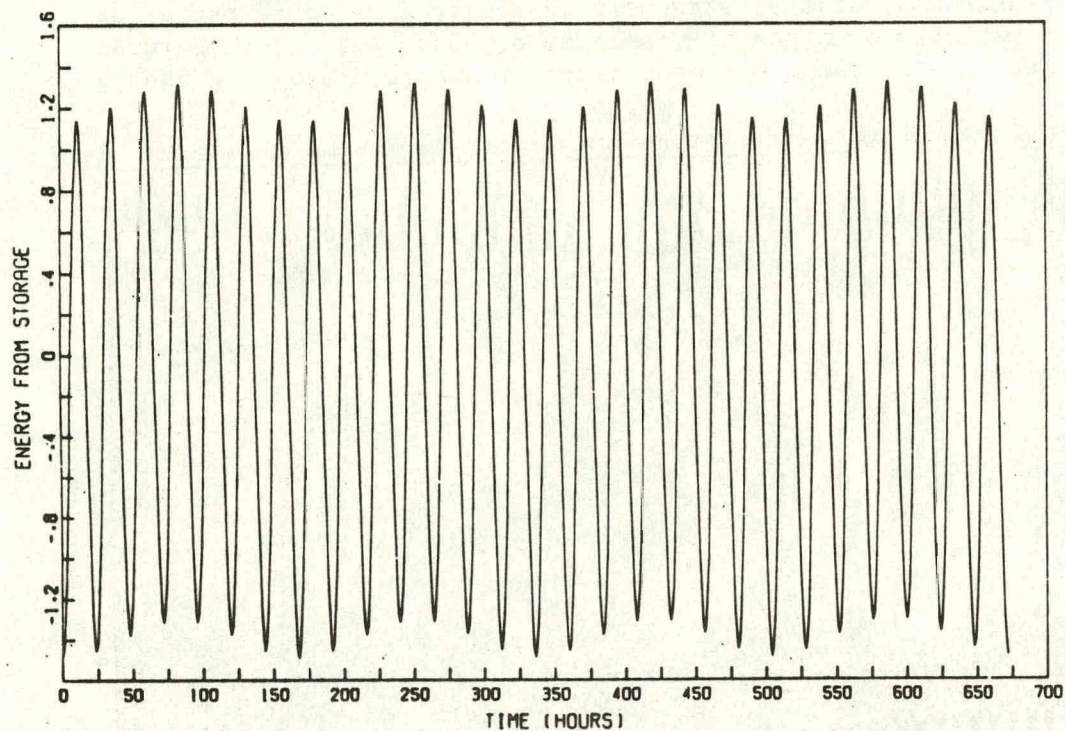

Figure 10. This is the energy from storage during the first month (July) only. Slight weekly variations are visible, but no seasonal component is obvious.

Analytical Approximations of Energy in Storage for Illustration Only

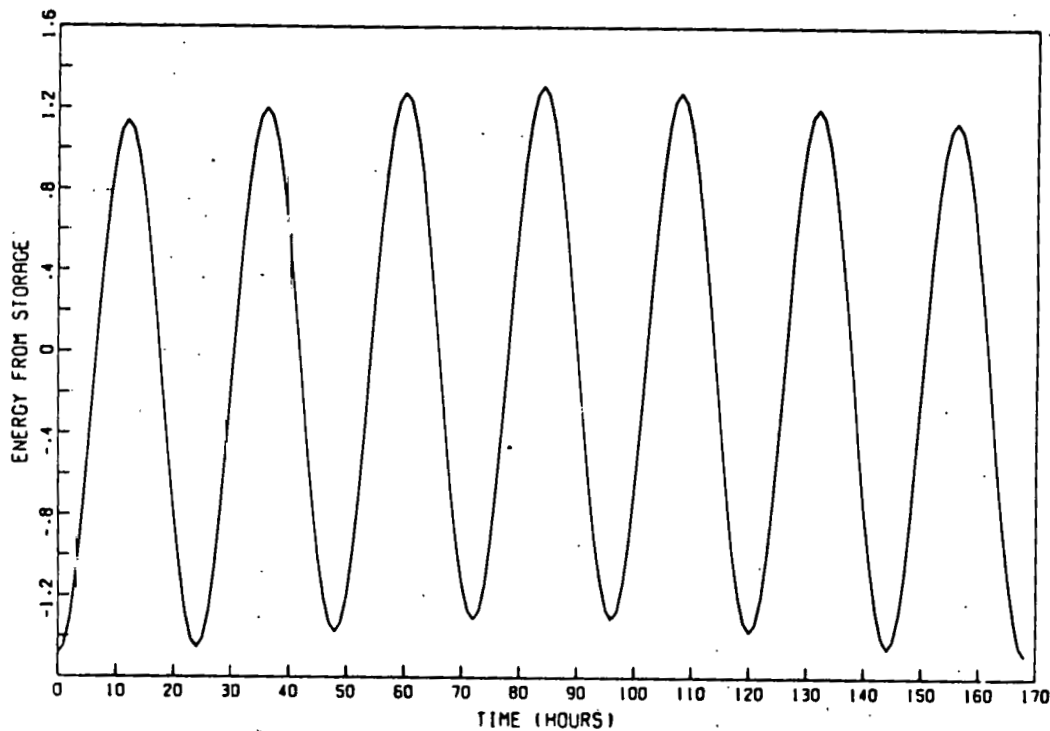

Figure 11. This is the energy from storage during the first week. Only daily variation are obvious.

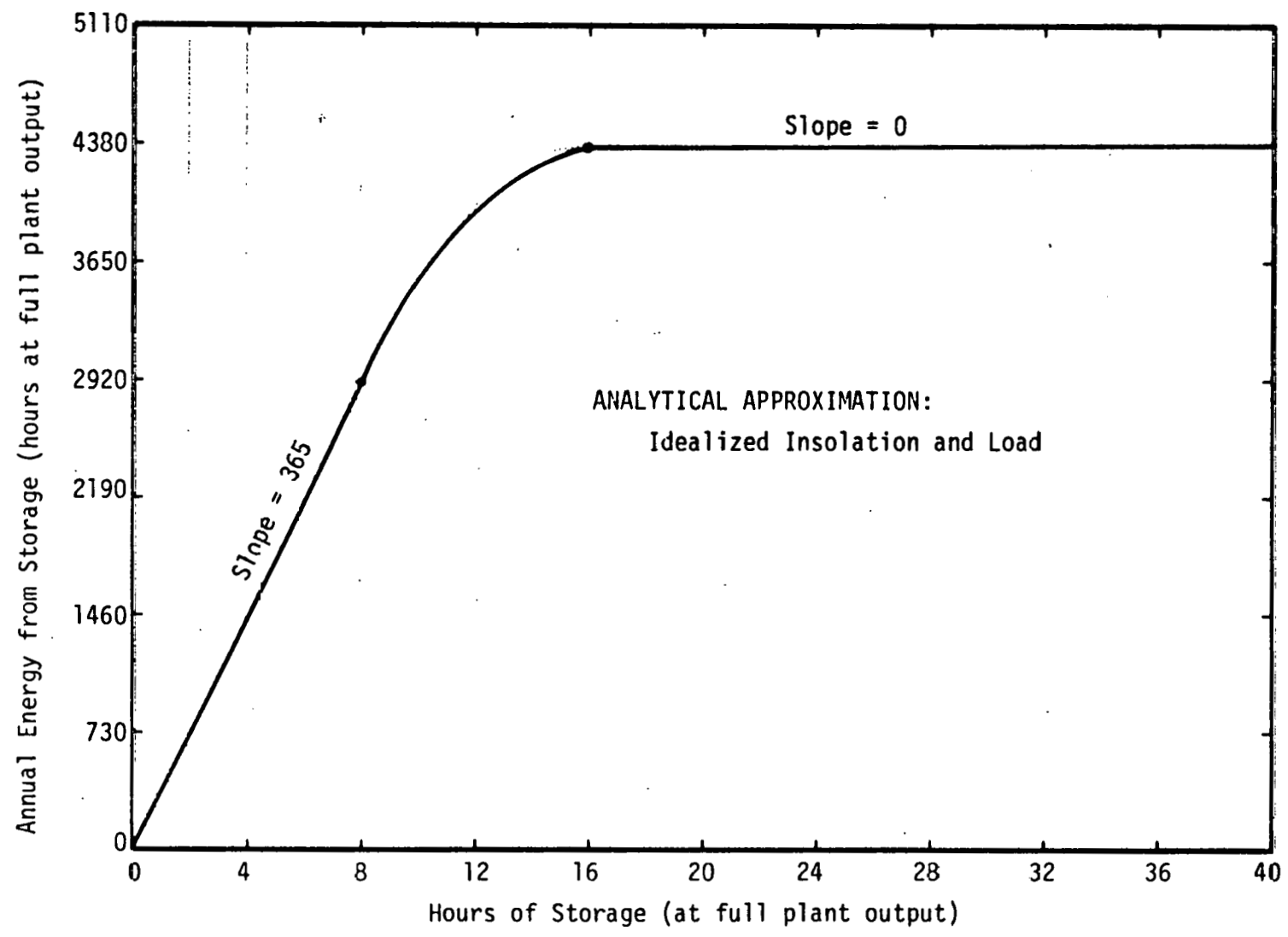

FIGURE 12

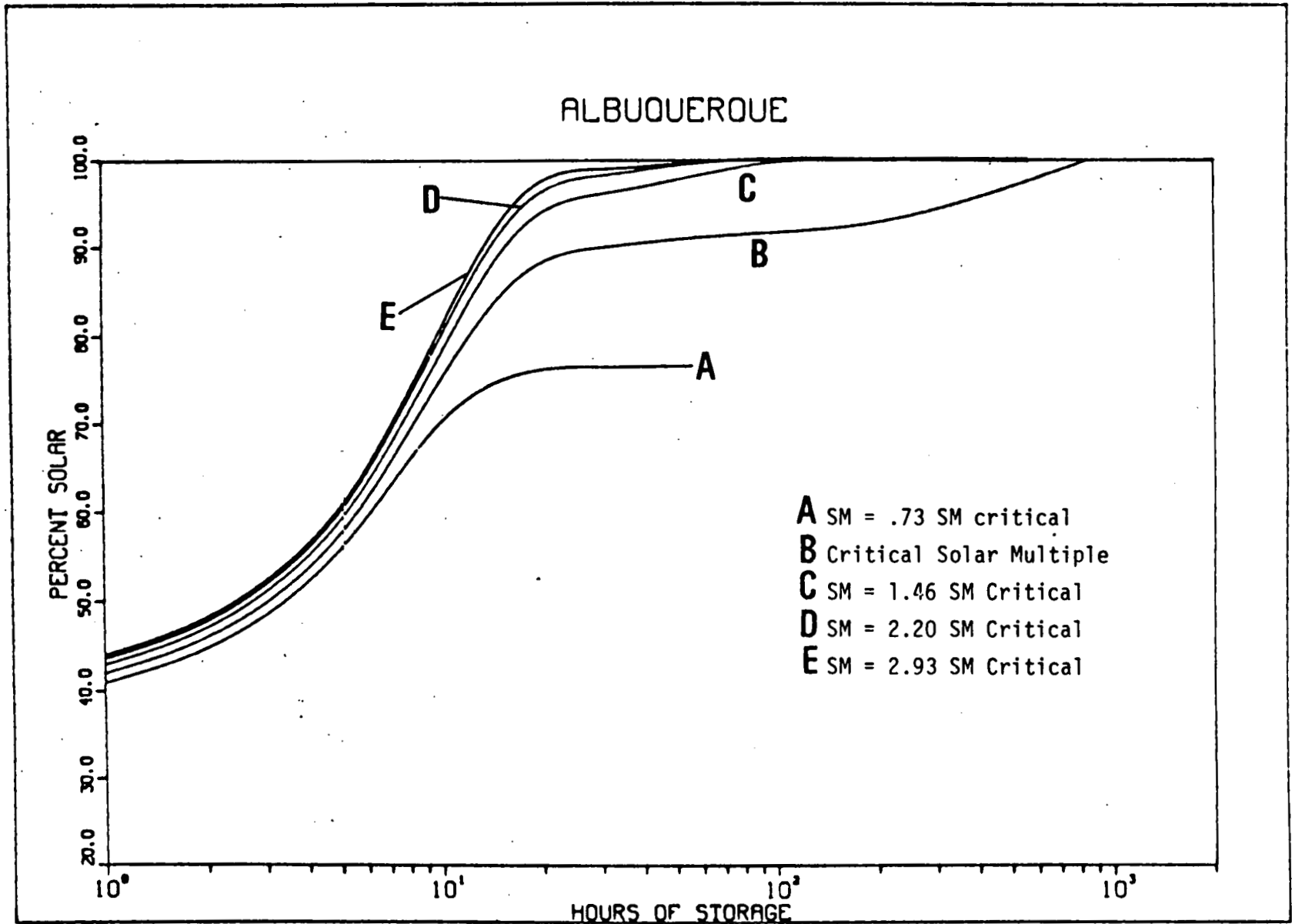

Figure 13. Percent Solar of a Constant Load versus Hours of Storage Over Three Orders of Magnitude

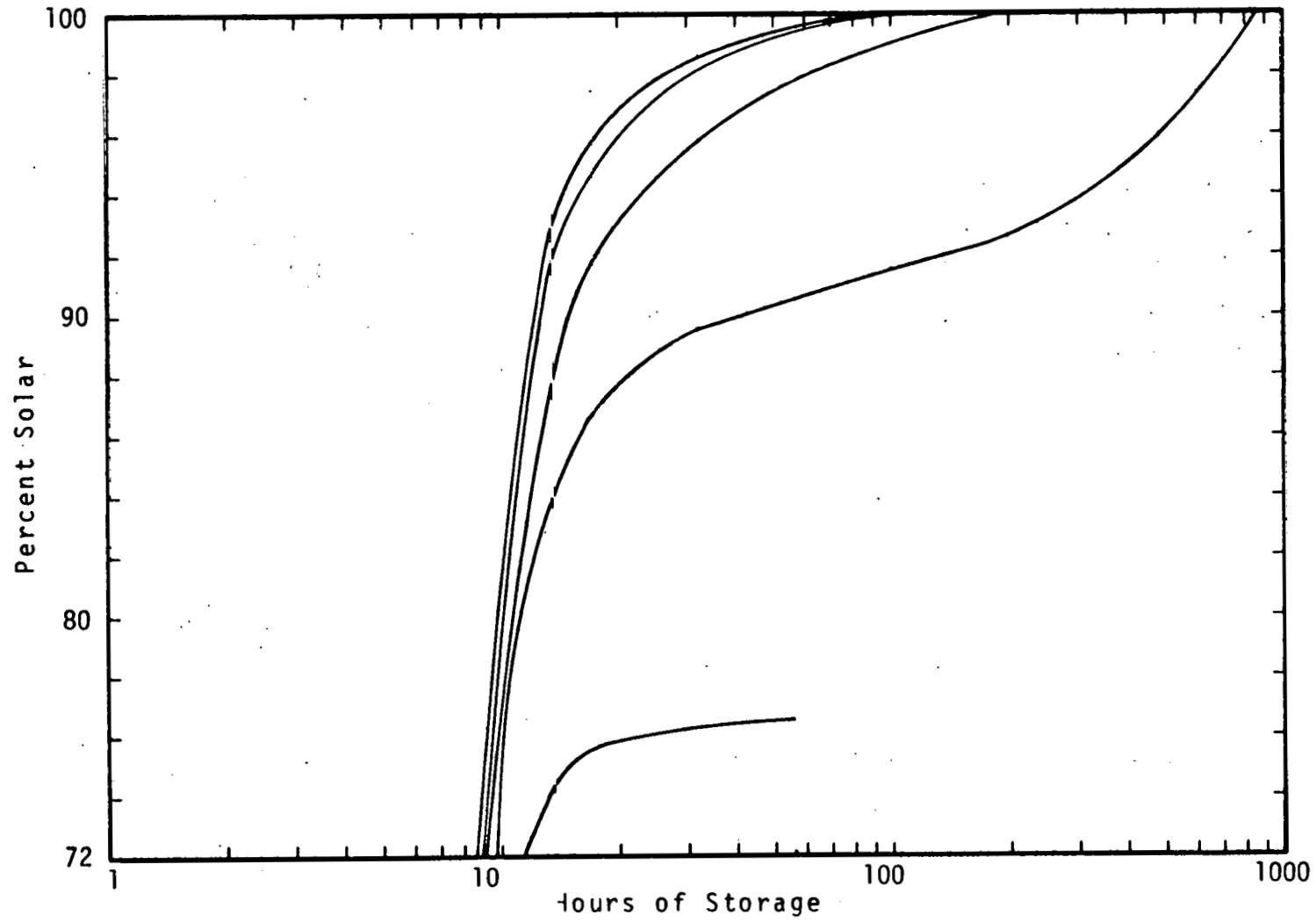

Figure 14. These are the Same Albuquerque Baseload Results as in Figure 13, But On an Expanded Performance Scale

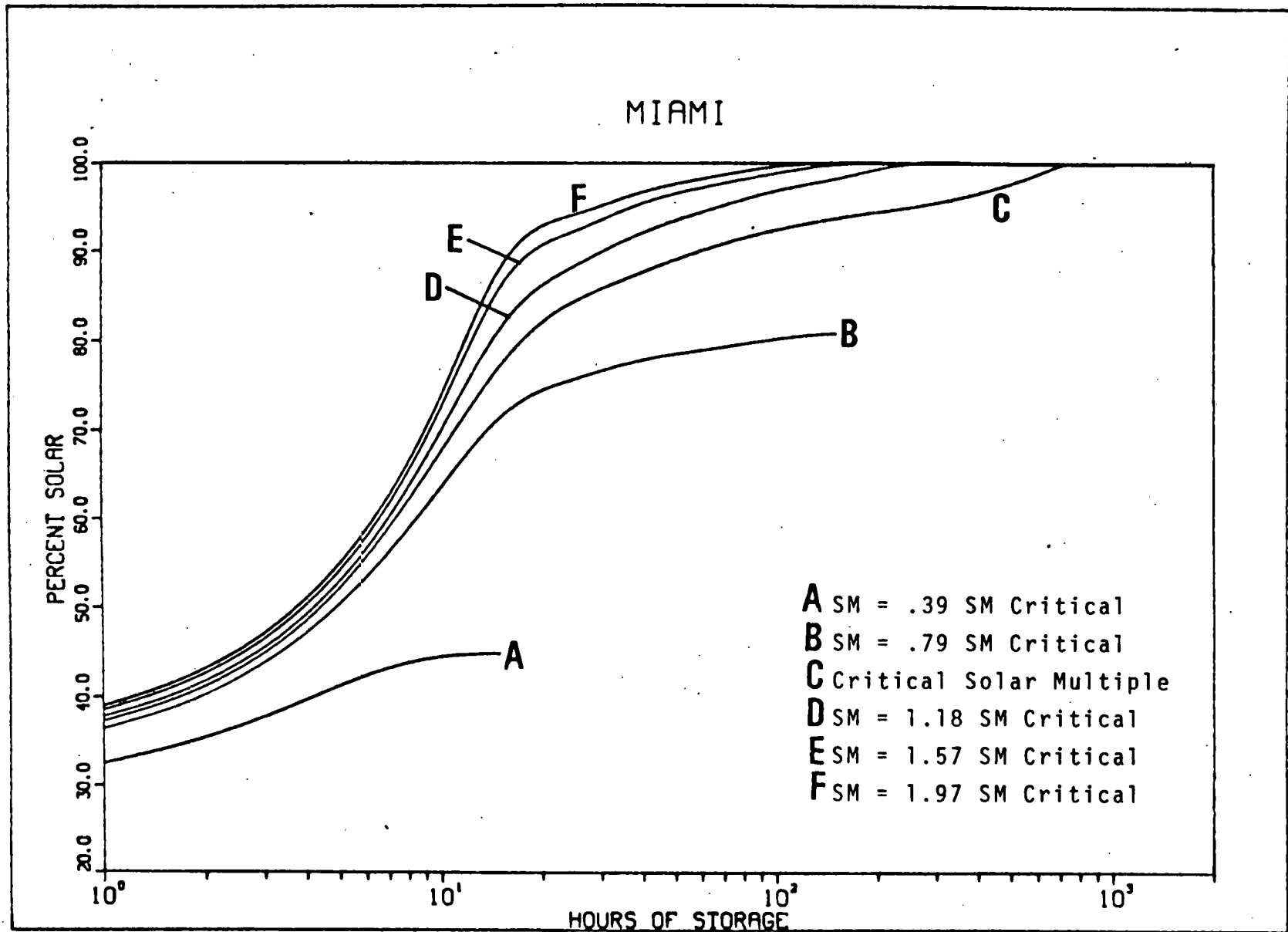

Figure 15. Miami Insolation, Baseload

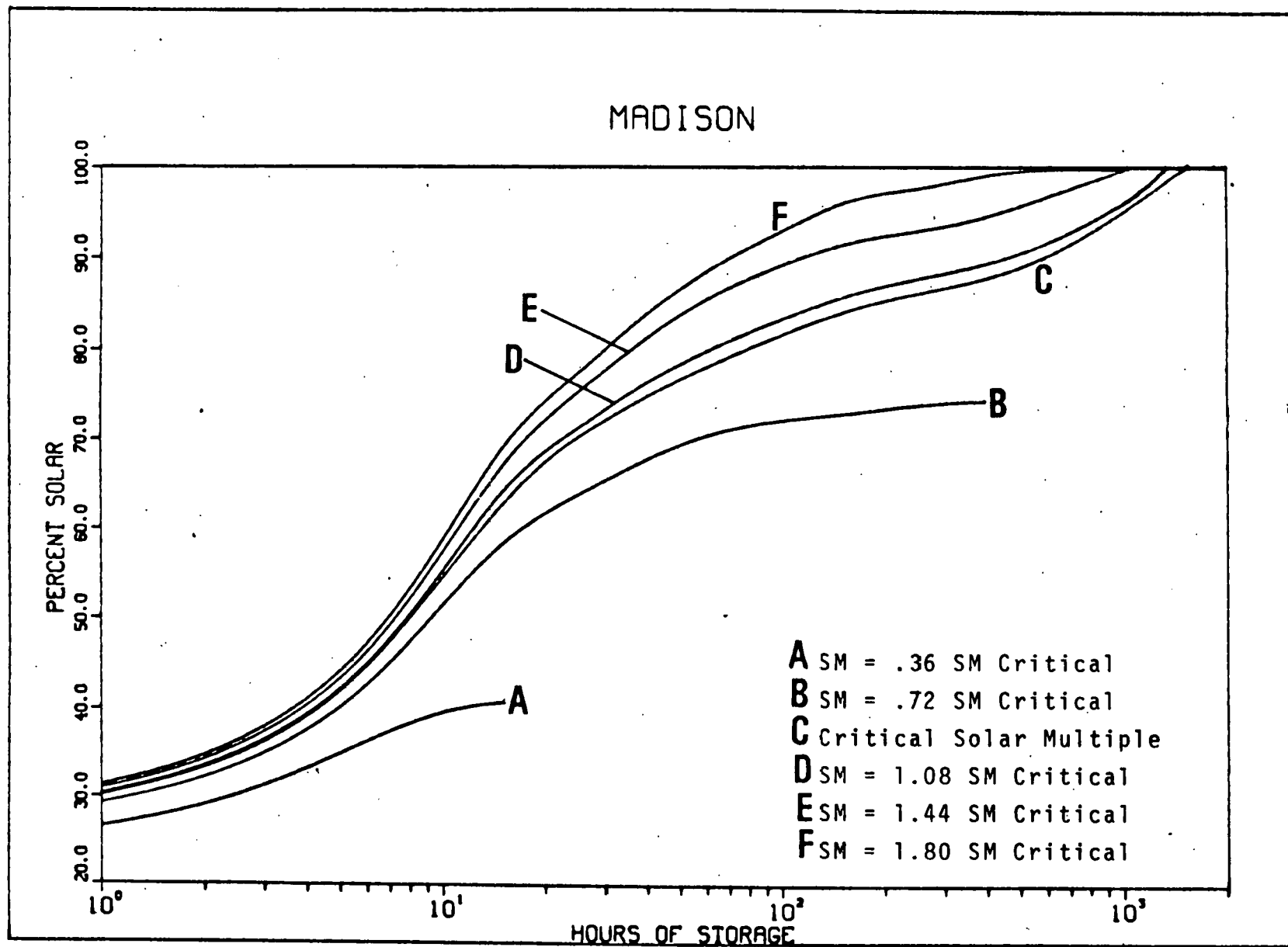

Figure 16. 1960 Madison Insolation, Baseload

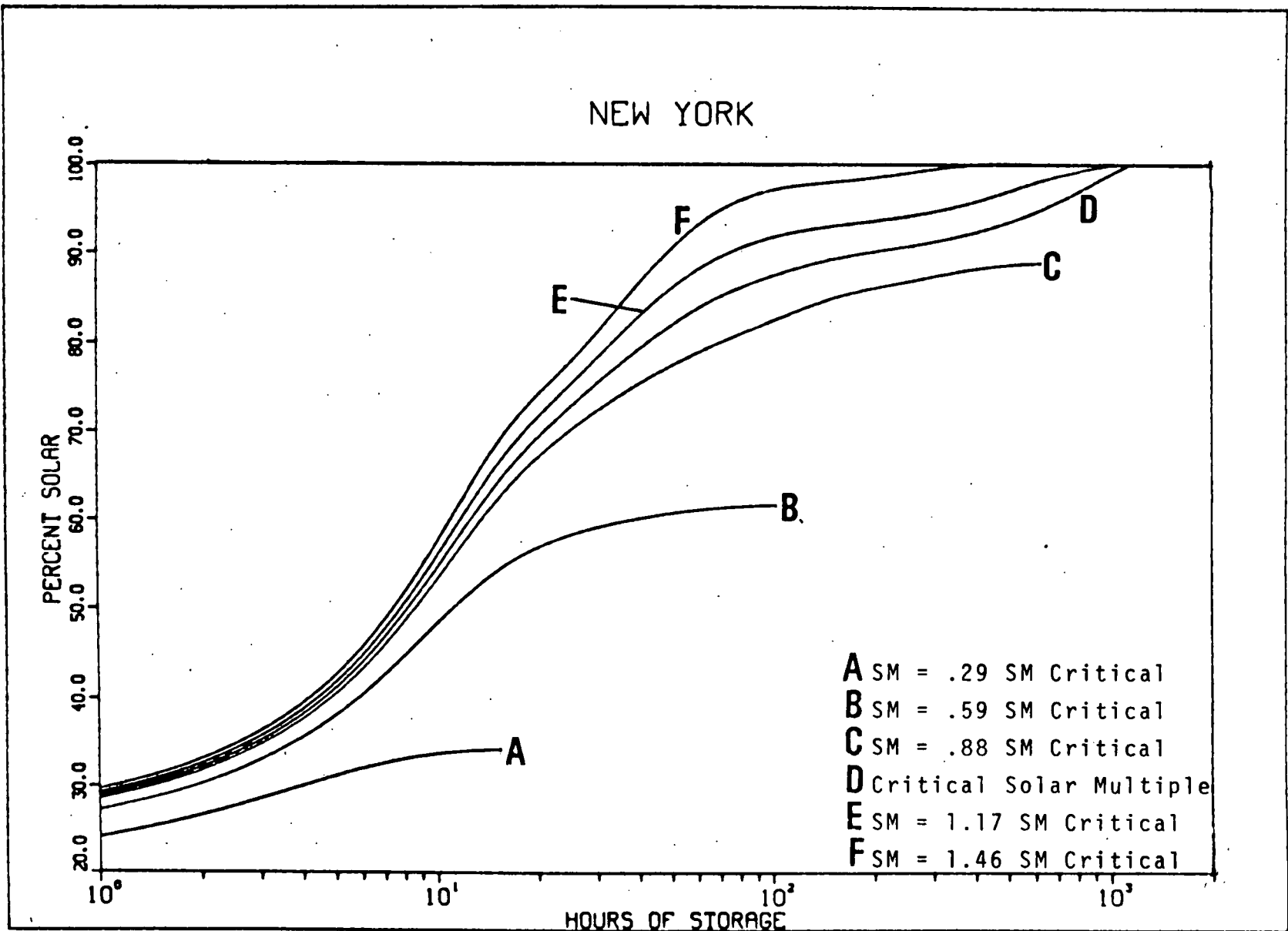

Figure 17. 1960 New York Insolation, Baseload

SUBSYSTEM SIZES, 2015 CLOSED CYCLE 7.5% FUEL ESCALATION

Percent Satisfied by Solar	Solar Multiple	Receiver Size (Mw _t)	Storage Charge Rate (Mw _t)	Storage Capacity (Hours)	\$60/M ² Relative Electricity Cost	\$120/M ² Relative Electricity Cost
4.81	.1	20	0	0	.97	.98
24.04	.5	100	0	0	.86	.90
42.76	1.	172	0	0	.75	.83
48.19	1.5	182	0	0	.74	.85
80	2.0	398	161	6.1	.64	.79
92	2.5	462	204	8.5	.60	.79
94.6	3.0	463	205	8.4	.61	.84
95.5	3.5	455	199	8.1	.63	.90
95.9	4.0	445	191	8.0	.66	.97
96.4	5.0	435	185	7.9	.73	1.11
100	3.0	596	286	52.8	.74	.97
100	3.5	550	250	36.1	.71	.98
100	4.0	519	233	34.6	.73	1.04
100	5.0	478	221	35.2	.80	1.18

TABLE I

YEAR 1990 RESULT SUMMARY

CLOSED CYCLE SO₂/SO₃ STORAGE

Fuel Escalation Rate (%)	Fraction Solar at Optimal Design Point	Storage at Optimal Design Point	Relative Cost at Optimal Design Point	Relative Cost at Optimal 100% Design Point
5	.43	None	.94	1.46
6.25	.43	None	.91	1.32
7.5	.43	None	.88	1.20
10.	.9	7.2 hours	.8	.98

TABLE II

YEAR 2015 RESULT SUMMARY

CLOSED CYCLE SO₂/SO₃ STORAGE

Fuel Escalation Rate (%)	Fraction Solar at Optimal Design Point	Storage at Optimal Design Point	Relative Cost at Optimal Design Point	Relative Cost at Optimal 100% Design Point
5	.43	None	.94	1.47
6.25	.9	7.0 hours	.76	1.03
7.5	.92	8.4 hours	.60	.71
10	.96	12.1 hours	.28	.33

TABLE III

1960 INSOLATION DATA BASELOAD DEMAND

LOCATION	CRITICAL SOLAR MULTIPLE	MAX USEFUL STORAGE (HRS)
Albuquerque	5.05	845
Miami	9.41	699
Madison	10.26	1454
New York	12.65	1083

TABLE IV

TABLE V. EXAMINATION OF YEAR TO YEAR VARIATION IN INSOLATION AND COMPONENT SIZES IN ALBUQUERQUE

<u>Year</u>	<u>Direct Normal Insolation (kWhr/m²)</u>	<u>Critical Solar Multiple</u>	<u>Critical Storage Size (hours)</u>
1953	2813	4.69	758
1954	2843	4.64	712
1955	2705	4.92	674
1956	2781	4.71	698
1957	2396	5.51	1144
1958	2515	5.26	906
1959	2613	5.01	768
1960	2604	5.05	845
1961	2655	4.94	950
1962	2730	4.87	925
1963	2654	4.94	594
1964	2651	4.98	807

THIS PAGE
WAS INTENTIONALLY
LEFT BLANK

Paper 2-7

CRITERIA FOR SELECTION OF THE THERMAL STORAGE
SYSTEM FOR THE 10 MW(e) SOLAR POWER PLANT
TO BE BUILT IN BARSTOW, CALIFORNIA

February 14, 1978

Lee G. Radosevich

Sandia Laboratories
Livermore, California 94550

The Department of Energy (DOE) has recently completed the design selection of a 10 MW(e) Solar Central Receiver Power Plant to be built in Barstow, California. The pilot plant design was selected based on studies conducted by Boeing, Honeywell, Martin Marietta and McDonnell Douglas. These studies included the conceptual design of a commercial size plant and a pilot plant scalable to the commercial plant and the design and testing of subsystem research experiments to verify concept feasibility. Honeywell, Martin Marietta and McDonnell Douglas each proposed system designs consisting of the collector, receiver, thermal storage, master control and electrical power generation subsystems while Boeing studied only the collector system.

As part of the design selection process, Sandia as technical manager of these pilot plant projects performed a technical and economic evaluation of each design. The work described here summarizes the procedure, criteria and methodology used for the selection of the thermal storage subsystem.

Three storage designs were proposed for the 10 MW(e) solar central receiver pilot plant. All designs use the sensible heat concept for storing thermal energy. The designs differ in that they employ various combinations of liquids and solids in series tanks as the storage media. The combinations give rise to different maximum storage temperatures and hence different maximum temperatures of steam produced from storage.

The McDonnell Douglas thermal storage subsystem (Figure 1) employs dual liquid (Caloria HT-43 heat transfer fluid) and solid (rock/sand) storage media with the thermocline principle applied to store both hot

and cold storage media in the same tank. In operation, heating of the media is achieved by removing colder fluid from the bottom of the tank, heating it in a heat exchanger with steam from the receiver and returning the fluid to the top of the tank. For heat extraction, the process is reversed.

The Martin Marietta thermal storage subsystem (Figure 2) is a two-stage sensible heat storage system using oil (Caloria HT-43 heat transfer fluid) in the main stage and an inorganic salt (HITEC) in the superheat stage. In operation, heating of the media is achieved by removing colder fluid from one tank, heating it in a heat exchanger with steam from the receiver, and returning it to a second tank. For heat extraction, the process is reversed. Operation of the oil and salt stages is similar.

The Honeywell thermal storage subsystem (Figure 3) is a two-stage sensible heat storage system using an oil/rock thermocline in the main stage and an inorganic salt in the superheat stage. This design, which was proposed subsequent to the cancellation of the Honeywell latent heat storage experiment, contains features of both the McDonnell Douglas and Martin Marietta designs.

The evaluation procedure for selection of the thermal storage design is shown in Figure 4. The procedure included an evaluation of both contractor defined systems and Sandia defined mix and match systems. Cost/performance results for the commercial plant systems were derived using contractor cost and performance data as well as any variations in the data which resulted from the technical and economic evaluation.

Selection criteria used in the evaluation process (Figure 5) are weighted 1/3 for commercial plant, 1/2 for pilot plant and 1/6 for confidence in design. Within each general category additional weightings

were established. Based on these criteria several key issues were identified during the technical and economic evaluation. These issues (Figure 6) were used along with the other selection criteria to arrive at the final design recommendation.

Since commercial plant cost/performance was a key issue and is of particular interest to this workshop the remaining discussion summarizes the cost/performance analysis (Figure 7) used to support the design selection. The basic approach in this analysis was to calculate the effect of thermal storage subsystem cost and performance on system busbar energy cost for commercial size plants. The analyses included parametric analyses which investigated several storage/receiver configurations, cost, storage capacity, solar multiple (a measure of the heliostat field ability to charge storage), and dispatch strategy. In the cost/performance analysis each storage concept was represented by several characteristics (Figure 8) in a power plant simulation model (Reference 1). This model calculated the annual plant electrical energy output for six plant configurations (Figure 9) in addition to all the contractor proposed systems.

Performance parameter studies (Figure 10) were conducted on storage capacity (1, 3, 5, 7, 9 hours), solar multiple* (1, 2, 3) and dispatch strategies. The sun following dispatch strategy minimizes energy production by operating directly from the receiver whenever possible; hence,

*A solar multiple of one represents the size of the mirror field required to produce the plant rated output when operating directly from the receiver at the plant design point.

storage usage is reduced. The peak shaving dispatch strategy uses storage to meet a peak evening demand; hence, storage usage is increased.

The results of the annual performance calculation are combined with the cost data in an economic model (Reference 2) to derive a levelized busbar energy cost. Cost parameter studies (Figure 11) included contractor cost estimates, Sandia adjusted estimates based on an evaluation of contractor cost data and uncertainties of ± 10 , $\pm 20\%$ about both contractor and adjusted estimates. A typical result (Figure 12) displays a comparison of Systems 4, 5 and 6 for 7 hours of storage and a solar multiple of 2. The figure shows the change in system energy costs as contractor storage subsystem cost estimates are varied. The McDonnell Douglas storage subsystem which gave the lowest system energy cost is taken as zero reference.

In summary (Figure 13), the selection of the thermal storage subsystem for the Barstow pilot plant considered a variety of technical and economic factors. Evaluation procedures and the methodology required for the cost/performance analyses were developed. The methodology developed was highly useful to the selection process and with suitable modification will be employed for the advanced, hybrid, and linear focus central receiver concepts under study.

REFERENCES

1. "STEABC - Solar Thermal Electric Annual Energy Calculator Documentation," Sandia Laboratories Report SAND77-8278, January 1978.
2. "BUCKS - Economic Analysis Model for Solar Electric Power Plants," Sandia Laboratories Report SAND77-8279, January 1978.

McDonnell Douglas Pilot Plant Thermal Storage

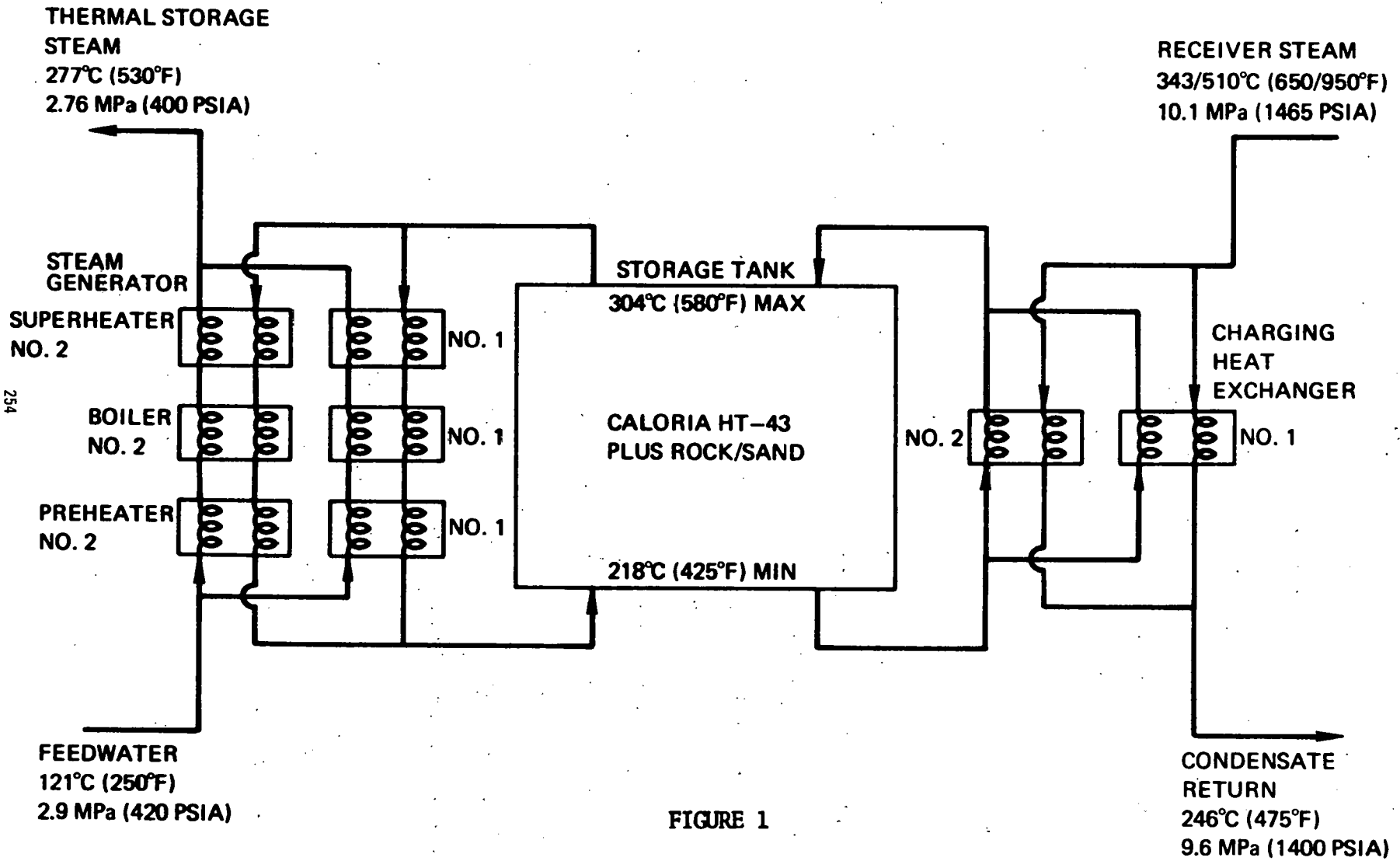

FIGURE 1

Martin Marietta Pilot Plant Thermal Storage

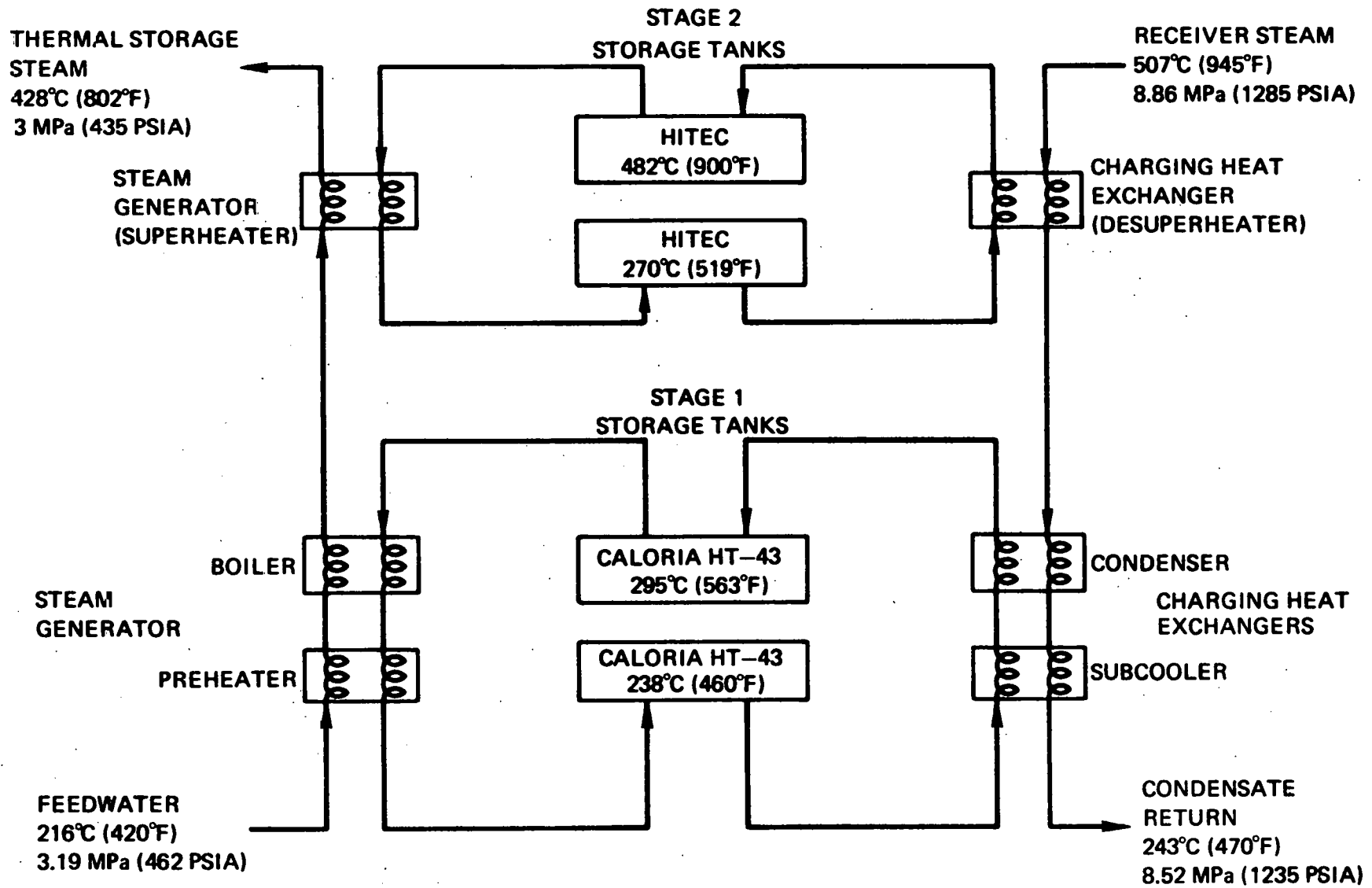

FIGURE 2

Honeywell Pilot Plant Thermal Storage

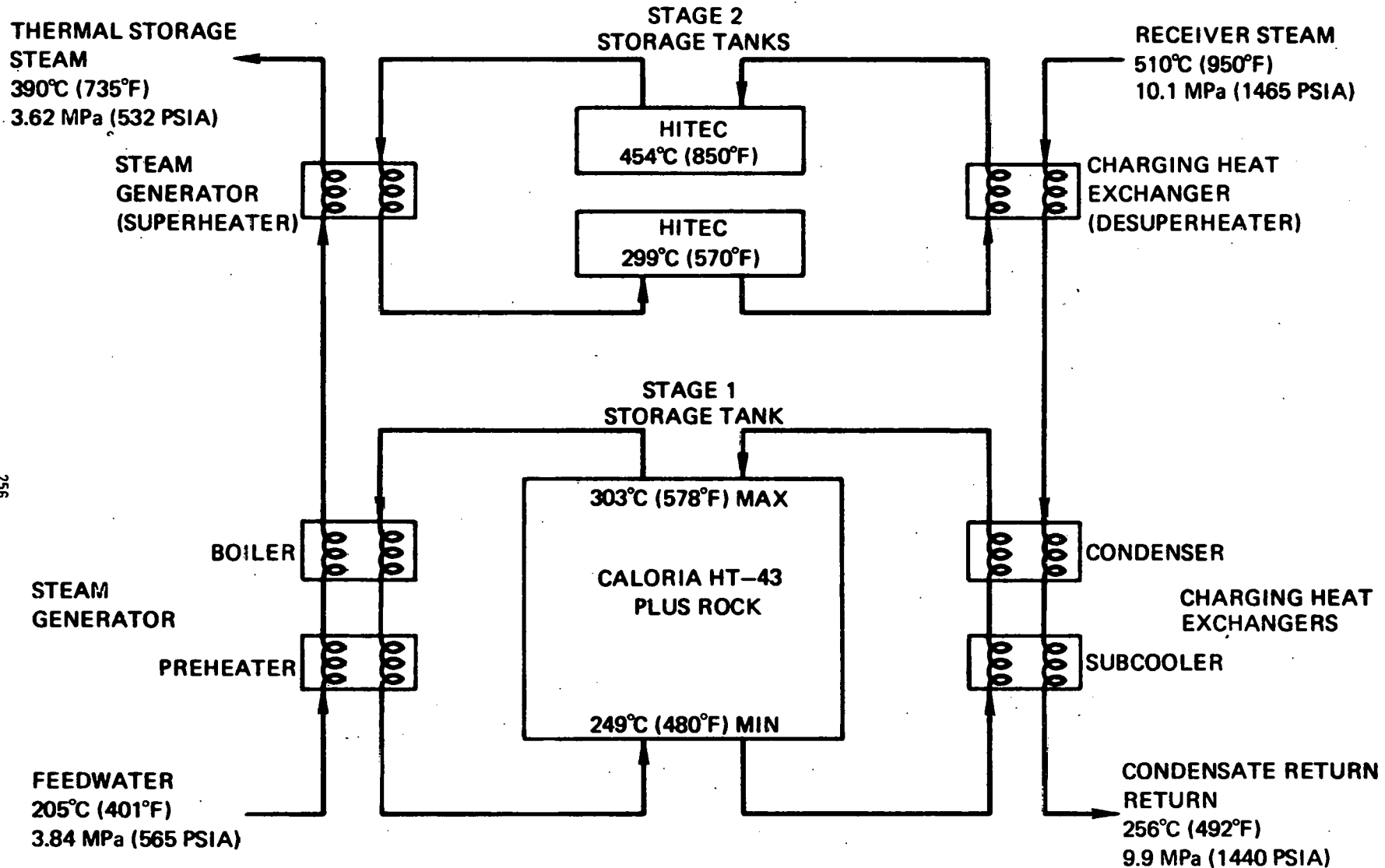

FIGURE 3

PILOT PLANT CONCEPTUAL DESIGN RECOMMENDATIONS PROCEDURES

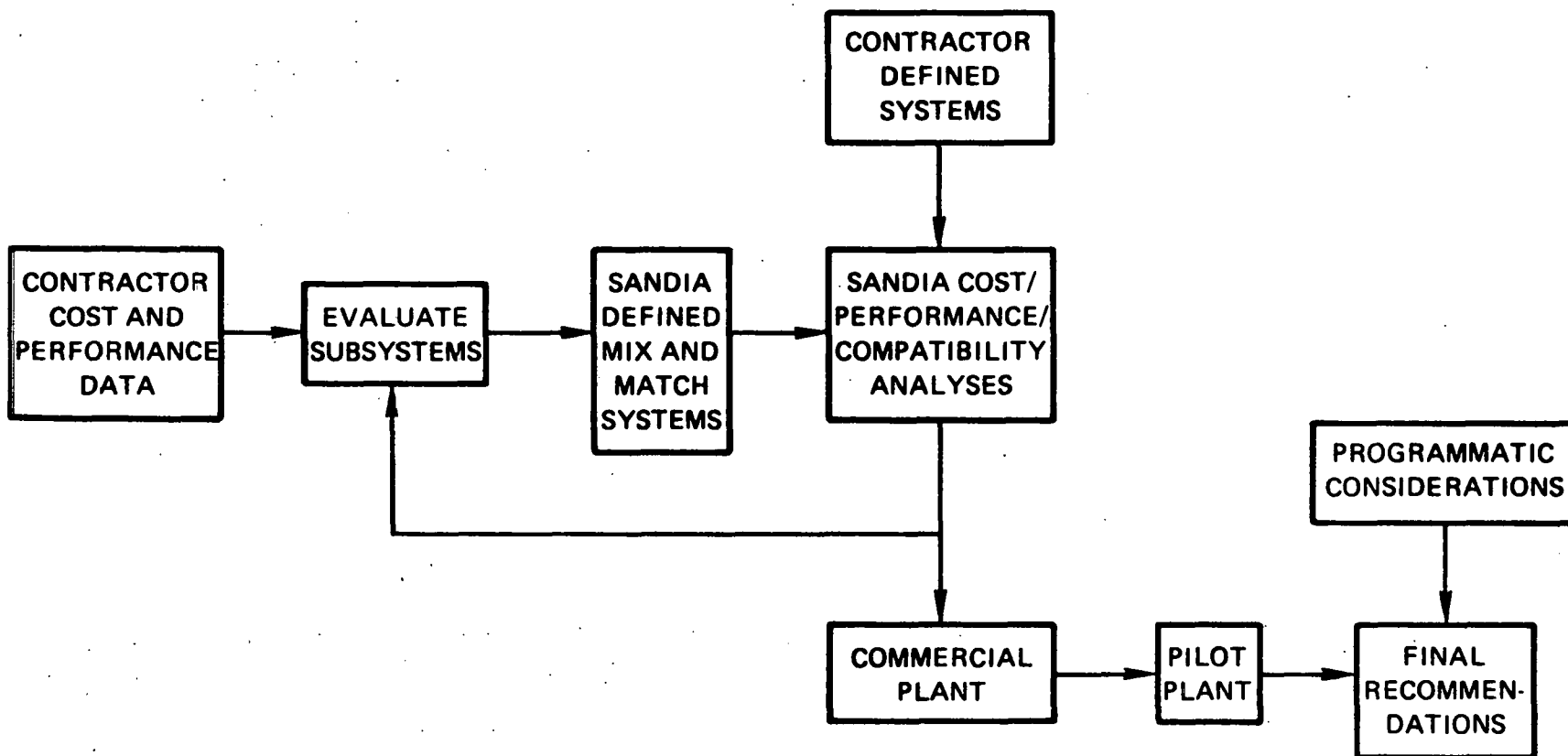

FIGURE 4

THEMAL STORAGE EVALUATION CRITERIA

COMMERCIAL DESIGN (ONE-THIRD)

- LIFE CYCLE ENERGY COST (SYSTEM)
- STRUCTURAL
- RELIABILITY AND MAINTENANCE
- CONTROL
- FABRICATION & INSTALLATION
- INTERFACE REQUIREMENTS
- SAFETY

PILOT PLANT (ONE-HALF)

- CHARGE & DISCHARGE RATES
- ENERGY AVAILABILITY
- AUXILIARY POWER
- MATERIAL DEGRADATION
- STRUCTURAL
- RELIABILITY & MAINTENANCE
- CONTROL
- FABRICATION & INSTALLATION
- SAFETY
- COST

CONFIDENCE IN DESIGN (ONE-SIXTH)

FIGURE 5

THERMAL STORAGE KEY ISSUES

	STRENGTHS	WEAKNESSES
McDONNELL DOUGLAS	<ol style="list-style-type: none">1. BEST COST/PERFORMANCE2. SIMPLE DESIGN3. SRE DEMONSTRATED TECHNICAL FEASIBILITY	<ol style="list-style-type: none">1. CYCLE EFFICIENCY2. FLUID MAKEUP
HONEYWELL	<ol style="list-style-type: none">1. CYCLE EFFICIENCY	<ol style="list-style-type: none">1. COST/PERFORMANCE2. SUPPORTING DATA LIMITED
MARTIN MARIETTA	<ol style="list-style-type: none">1. CYCLE EFFICIENCY2. LOW RISK	<ol style="list-style-type: none">1. WORST COST PERFORMANCE2. FLUID MAKEUP

FIGURE 6

THERMAL STORAGE COST/PERFORMANCE ANALYSIS

BASIC APPROACH - CALCULATE EFFECT OF THERMAL STORAGE SUBSYSTEM COST AND PERFORMANCE ON SYSTEM BUSBAR ENERGY COST FOR COMMERCIAL SIZE PLANT

PARAMETERS VARIED

- STORAGE/RECEIVER CONFIGURATION
- COST
- STORAGE CAPACITY
- SOLAR MULTIPLE
- DISPATCH STRATEGY

FIGURE 7

THERMAL STORAGE MODEL CHARACTERISTICS

- STORAGE CAPACITY
- MINIMUM, MAXIMUM CHARGE RATES
- MINIMUM, MAXIMUM DISCHARGE RATES
- AUXILIARY ELECTRICAL AND THERMAL POWER REQUIREMENTS
- HEAT LOSS
- THERMOCLINE DEGRADATION (AS APPLICABLE)
- STORAGE FLUID MAKEUP

FIGURE 8

SYSTEM STUDY MATRIX

<u>SYSTEM</u>	<u>HELIOSTAT</u>	<u>RECEIVER</u>	<u>THERMAL STORAGE</u>
1	MDAC	MDAC	MDAC
2	MDAC	MDAC	MM
3	MDAC	MDAC	HW
4	MDAC	MM	MDAC
5	MDAC	MM	MM
6	MDAC	MM	HW

FIGURE 9

PERFORMANCE PARAMETER STUDIES

- **STORAGE CAPACITY - 1, 3, 5, 7, 9 HOURS**
- **SOLAR MULTIPLE - 1, 2, 3**
- **DISPATCH STRATEGY - SUN-FOLLOWING, PEAK-SHAVING**

FIGURE 10

COST STUDIES

- CONTRACTOR COMMERCIAL PLANT THERMAL STORAGE COST ESTIMATE
- SANDIA ADJUSTED COMMERCIAL PLANT THERMAL STORAGE COST ESTIMATE
- UNCERTAINTIES OF ± 10 , $\pm 20\%$ ABOUT BOTH CONTRACTOR AND SANDIA ESTIMATES

FIGURE 11

THERMAL STORAGE COST/PERFORMANCE

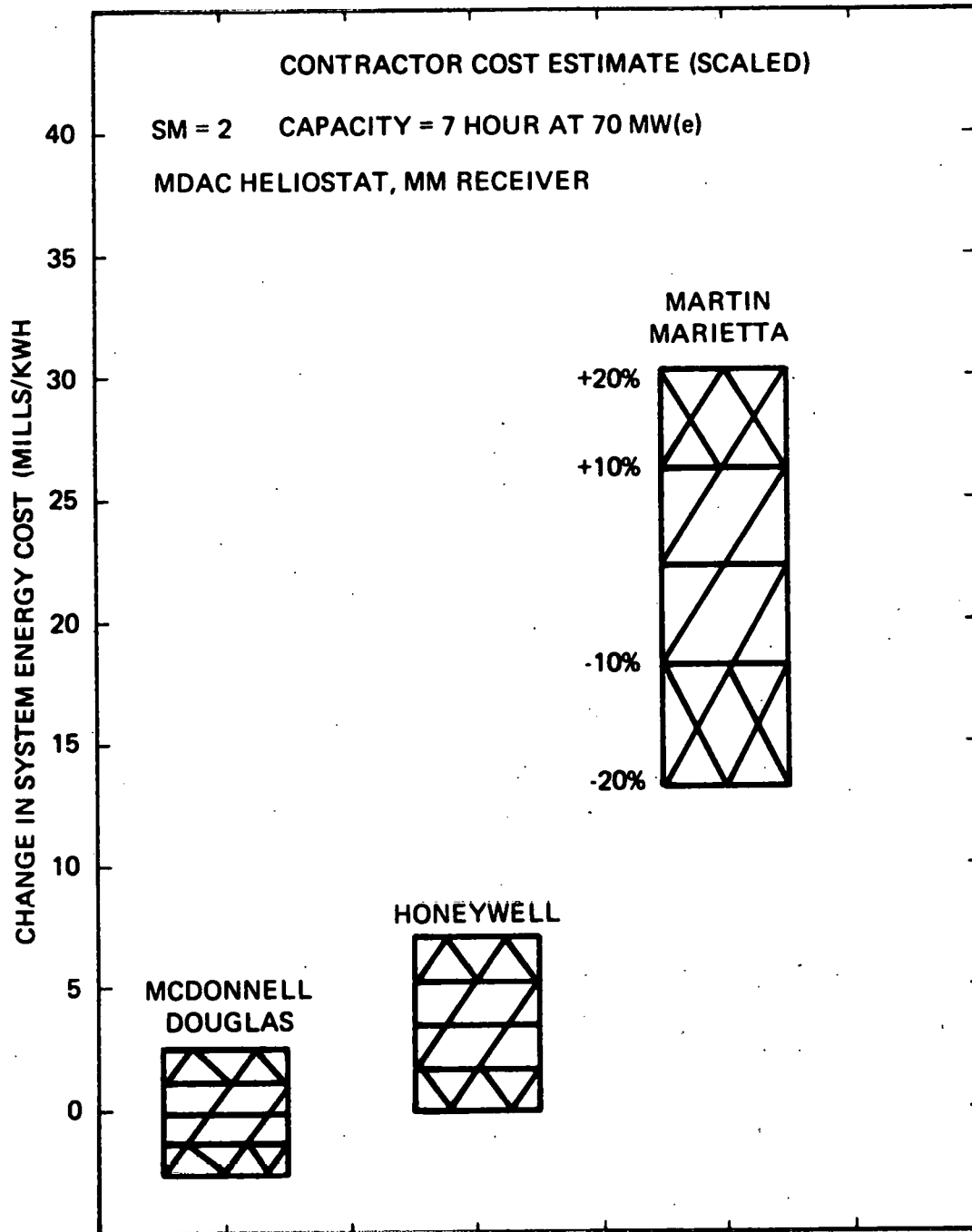

FIGURE 12

SUMMARY

- EVALUATION PROCEDURE ESTABLISHED FOR SELECTION PROCESS
- METHODOLOGY DEVELOPED FOR COST/PERFORMANCE EVALUATION
- DESIGN SELECTED FOR THE 10 MW(e) BARSTOW PILOT PLANT
- SIMILAR APPROACH WILL BE USED FOR ADVANCED, HYBRID AND LINEAR FOCUS SYSTEMS

FIGURE 13

NEED FOR SPECIFIC REQUIREMENTS
BY STORAGE SYSTEM DEVELOPMENT TEAMS

APPLICATIONS WORKSHOP:
THERMAL STORAGE INTEGRATED INTO SOLAR POWER PLANTS
GOLDEN, COLORADO
FEBRUARY 14-15, 1978

JAMES E. CALOGERAS
NASA-LEWIS RESEARCH CENTER
POWER GENERATION AND STORAGE DIVISION

Need for Specific Requirements By Storage System Development Teams

The subject of this presentation concerns the need for a set of guidelines prior to the initiation of a storage technology development effort that is aimed at satisfying the requirements of a range of solar power applications. I intend to introduce these requirements, show a few examples, and hopefully stimulate some thoughts for discussion both this afternoon and particularly at the plenary session tomorrow.

The flow of storage system development is presented in figure 1. Earlier Larry Gordon indicated the process of system studies, concept development and technology validation leading to a state of technology readiness. The feedback from the application sector has been added to close the loop.

There are two points in the flow where input from the application sector is critical. The first occurs when a general range of system requirements is provided, including parameters such as temperature range of interest, nominal power levels, a representative range of storage durations, and programmatic targets of schedule and cost. From these inputs, numerous sensible, latent and thermochemical technologies are coarsely screened for general applicability. By considering a representative system application, in this case a solar thermal power system, as a black box, the coarsely screened storage technologies are perturbed to identify those specific technologies which best fit the reference application. Where the most promising concepts require development, a program can be initiated to develop and validate the technologies within the schedular and cost constraints of the programmatic targets.

The second critical feedback occurs immediately prior to the initiation of large-scale development. Here development becomes appreciably more expensive; and refinement of the reference application, as well as the initiation of a study to evaluate those concepts under development and alternatives to those concepts for eventual end use would be prudent. The scope of the validation effort can now be determined, and earlier system studies can be flexed by treating a storage concept as a black box and perturbing the remaining subsystems to evolve the best solar/storage integrated system.

In the previous figure all of the requirements needed by development teams to bring a technology to a state of readiness were discussed. Figure 2 summarizes these requirements.

Solar thermal program priorities and targets are needed; not so much with respect to various elements of the solar thermal program but rather with respect to the need for storage subsystems. For which system application is storage subsystem development needed most; and by when?

System studies are needed to: (1) identify specific storage system characteristics, operational requirements and development requirements; (2) evaluate developed concepts for validation, (and decide what constitutes validation); and (3) evolve the best solar/storage integrated system.

Throughout the process, the mutual interaction of all participants in the solar thermal, the power generation and the storage communities is of course needed, in order to afford the solar thermal power alternative its best chance.

Figure 3 graphically depicts the need for early guidelines from the solar thermal application sector. Listed at the top of this figure are those applications that require, or may require, some amount of thermal energy storage. There are, of course, several variations of system application within each category. Candidate conversion systems and somewhat arbitrary ranges of storage duration are shown at the front and top of the matrix block, respectively. The storage technologies categorized by Larry Gordon and Taz Bramlette, make up the length of the block. Obviously, a storage technology program would not encompass each application sector, nor even groupings of sectors, with equal emphasis at the same time.

The Solar Thermal Office of the DOE-SOLAR did provide a matrix of system applications, power conversion options and duration requirements about a year ago. Based in large part on this matrix, the storage program for solar applications 'thrust' that Larry Gordon reviewed was initiated.

This matrix should periodically be updated to reflect program re-evaluations and redirections, and prioritized to reflect current emphasis and schedular constraints.

The milestone schedule chart presented in figure 4 is meant simply to serve as an example of the need for a time frame in which to develop a technology. This particular chart refers to the industrial applications sector in which concepts will be developed initially for near-term applications.

Given a system application milestone, such as (5), in which a demonstration of thermal energy storage for industrial applications would be initiated by the end use application sector, the entire development process of system studies, concept development and technology validation was projected such that the transfer of those respective technologies corresponded to that milestone.

With respect to the solar thermal program, milestone (5) could refer to the initiation of conceptual designs for a pilot plant or the initiation of large-scale systems experiments in any of the central or dispersed power applications. Milestone (4), on the other hand could be an experiment on the order of the Subsystem Research Experiments for the Baseline 10 MWe Pilot Plant program, or a test in the Solar Total Energy System Test Facility at Sandia-Albuquerque. In any case, validations of the storage system technology must be made prior to consideration of that concept in a system demonstration.

Figure 5 is an example of the system study requirement needed to guide a storage development program. This particular study, done by Boeing Engineering and Construction (BEC), examined various sensible, latent and thermochemical storage concepts in relation to a reference solar central power system which used a closed cycle Brayton power conversion system. The reference system had a six hour requirement for extended operation.

Although several assumptions were required to provide subsystems and system cost and performance estimates, B.E.C. concluded the following:

- (1) The sensible heat storage scheme with MgO bricks in a welded steel vessel was the best of the available technologies.
- (2) The thermochemical concepts, with inherent transport and thermodynamic characteristics, offered the most flexibility.
- (3) The latent heat concept offered the best cost advantage at the storage duration of interest.

An interesting inclusion to the study was made by Professor Gilli, University of Graz, Austria, who estimated that a prestressed cast iron vessel would reduce the containment cost of the sensible heat scheme by 50-percent, resulting in about a 33-percent reduction of storage system costs.

These kinds of studies are needed to direct the development of storage technologies for the entire spectrum of solar thermal applications. The need for real working relationships among all interests in solar power generation is also obvious.

TECHNOLOGY DEVELOPMENT FLOW

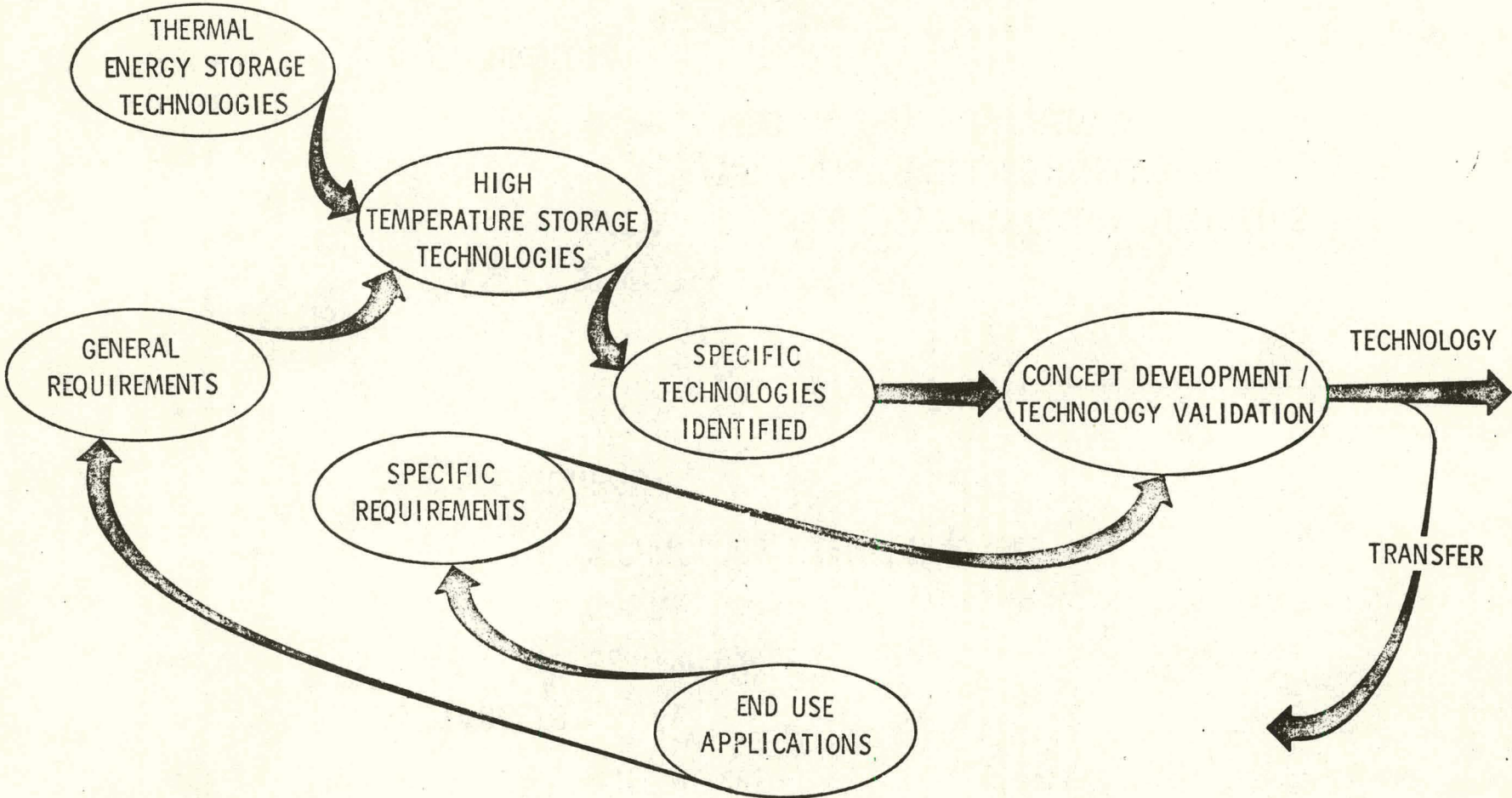

271

FIGURE 1

REQUIREMENTS

GENERAL

- o PRIORITIES
 - SOLAR THERMAL SYSTEMS AND EXPERIMENTS
 - MILESTONES
- o TARGETS
 - PERFORMANCE
 - COST
 - TECHNOLOGY TRANSFER DATES
- o INTERCOURSE

SPECIFIC

- o SYSTEM STUDIES
 - OPTIMUM STORAGE SYSTEM CHARACTERISTICS
AND OPERATIONAL REQUIREMENTS
 - LEVEL OF TECHNOLOGY REQUIRED
- o TECHNOLOGY VALIDATION

FIGURE 2

SOLAR / STORAGE SYSTEM INTEGRATION

CENTRAL POWER SYSTEMS

- o BASELINE
- o ALTERNATIVE
- o ADVANCED
- o HYBRID

DISPERSED POWER SYSTEMS

- o TOTAL ENERGY
- o IRRIGATION PUMPING
- o SMALL POWER
 - SMALL COMMUNITY
 - OTHERS

INDUSTRIAL SYSTEMS

- o HIGH TEMPERATURE PROCESS HEAT
- o OTHERS

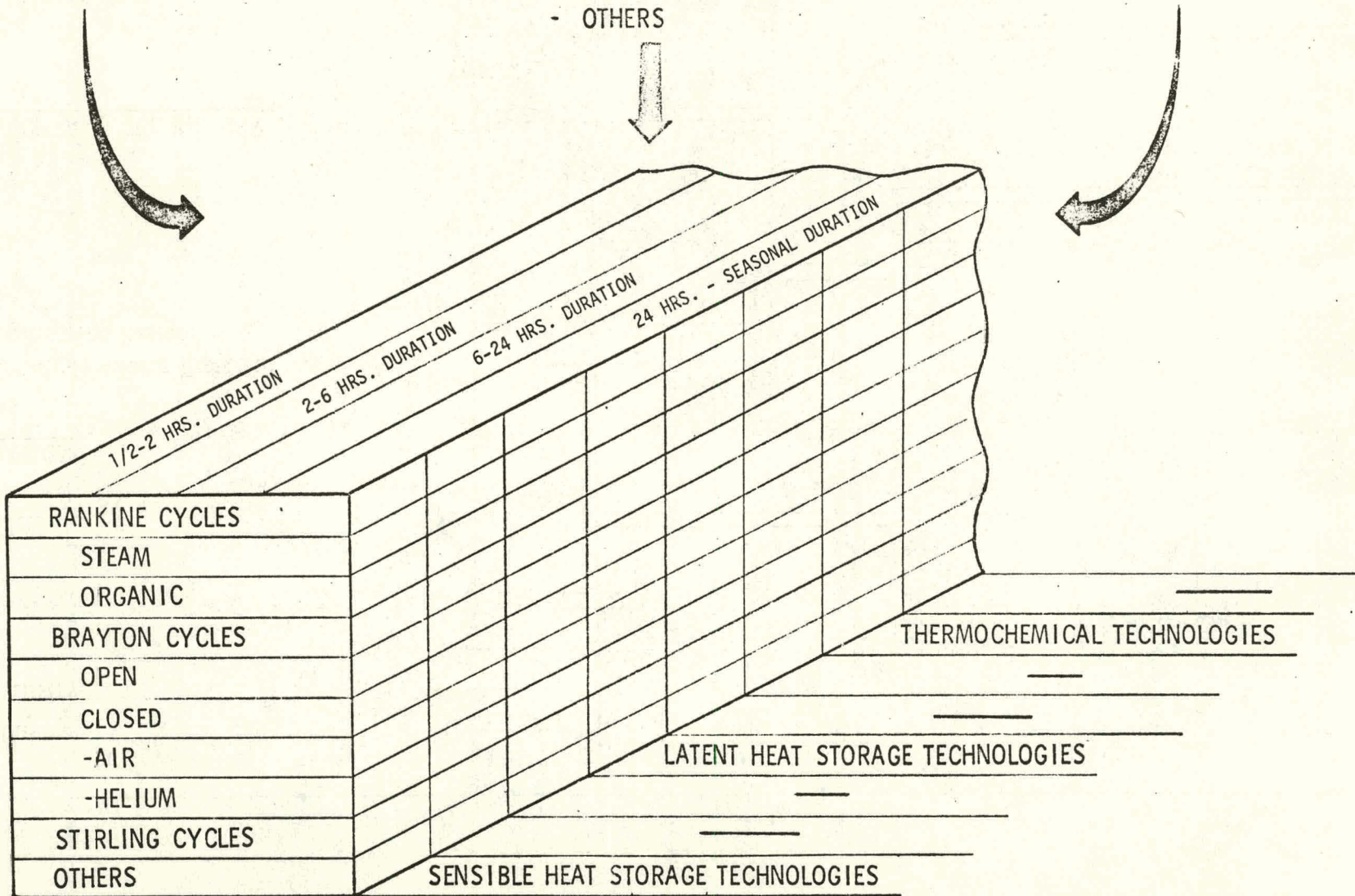
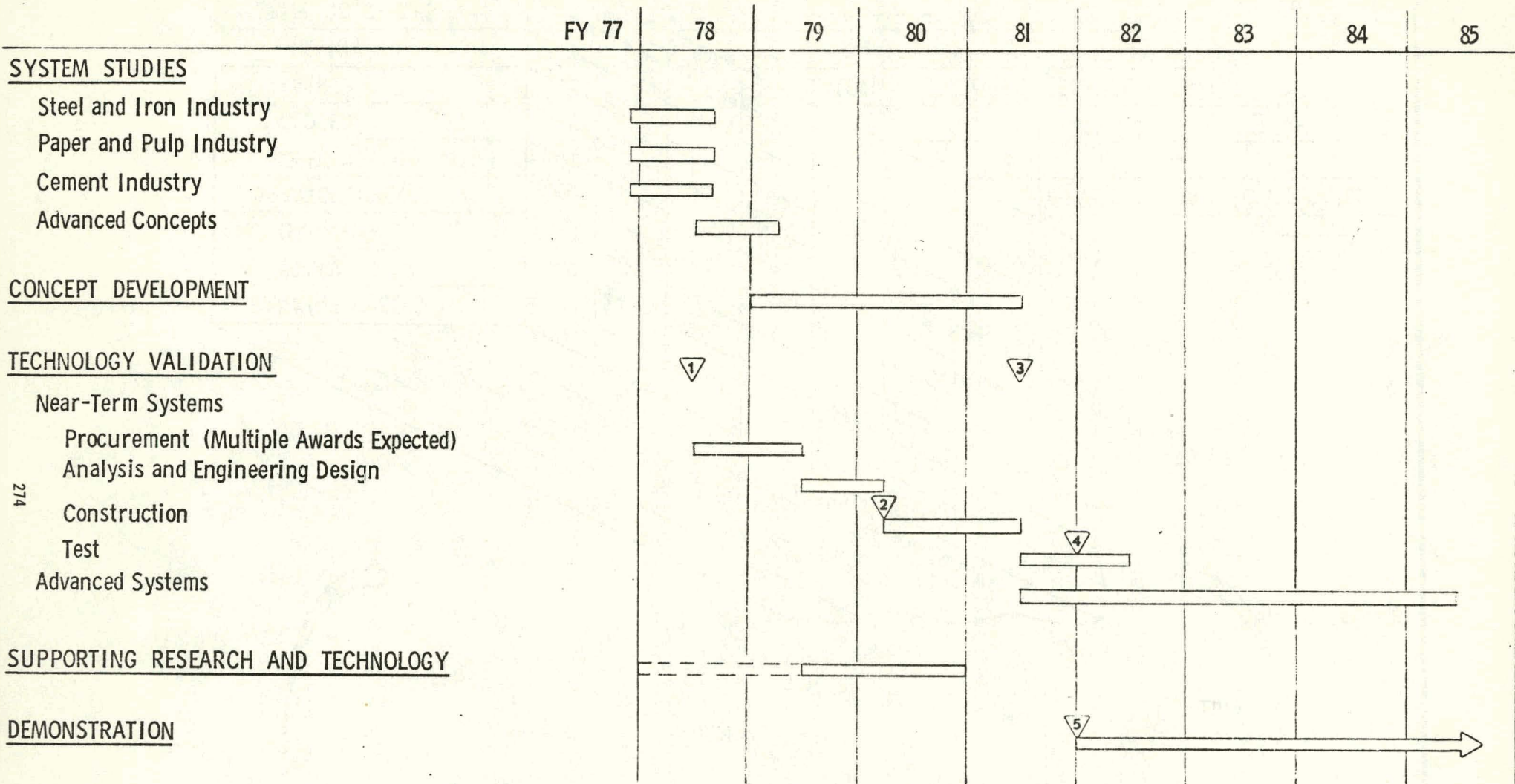

FIGURE 3

THERMAL ENERGY STORAGE FOR INDUSTRIAL APPLICATIONS



274

MILESTONES

1. Select Near-Term Concepts for Validation
2. Proceed with Near-Term Construction
3. Select Advanced Concept for Validation
4. Establish Near-Term Proof-Of-Concept
5. Initiate Near-Term Demonstration

FIGURE 4

EXAMPLE OF SYSTEM STUDY REQUIREMENT
FOR
SOLAR BRAYTON CENTRAL POWER SYSTEM⁽¹⁾

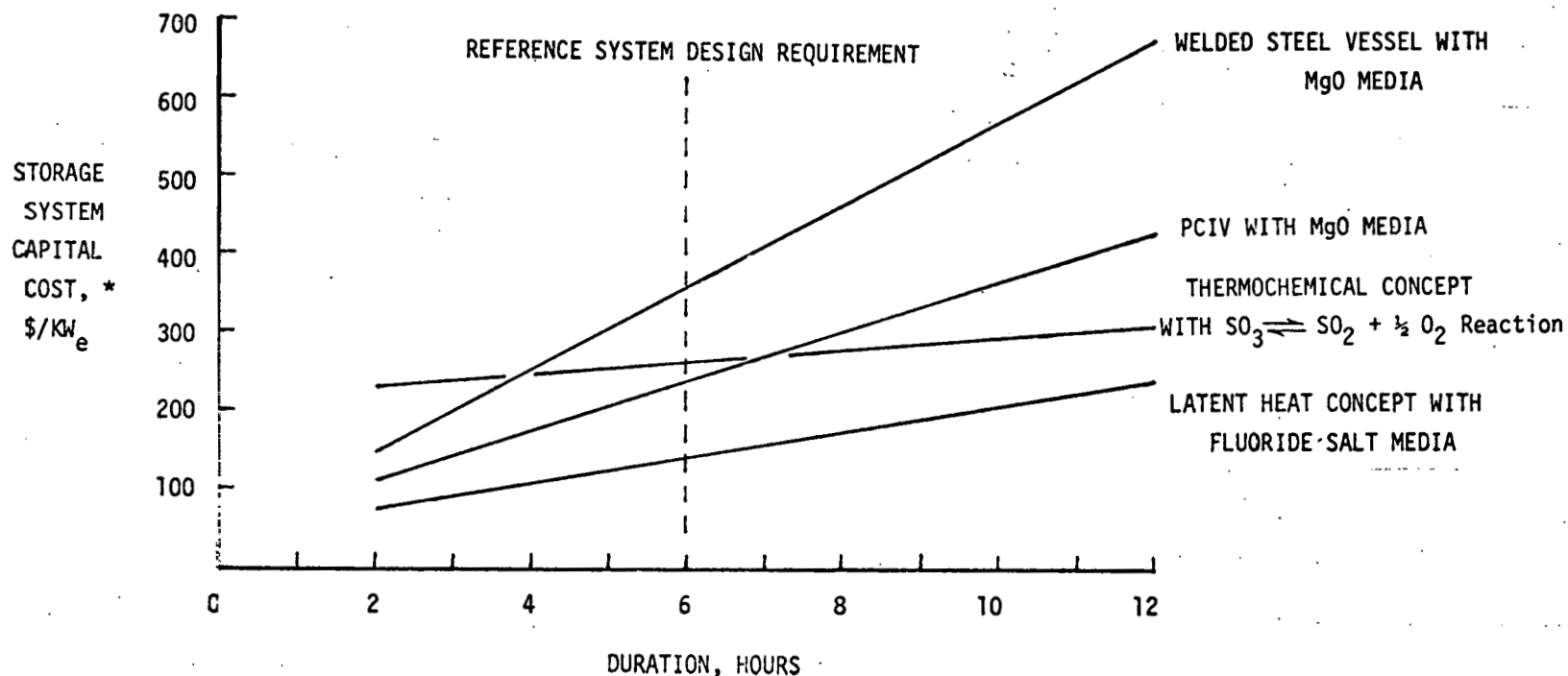

* STORAGE SYSTEM CAPITAL COST = $\$/Kw_e + \$/Kw_eH \cdot HOURS$

(1) BASED ON FINAL TECHNICAL REPORT, VOLUME 1, "ADVANCED THERMAL ENERGY STORAGE (TES) SYSTEMS",
BOEING ENGINEERING AND CONSTRUCTION; JULY 1 - DECEMBER 31, 1976 ERDA CONTRACT NO. EY-76-C-03-1300

FIGURE 5