

500
6-16-84 JS (2)

DR# 0120-1

DOE/ET/20356--11
DE84 009746

Energy

S
O
L
A
R

SUMMARY OF PHOTOVOLTAIC SYSTEM PERFORMANCE MODELS

By
J. H. Smith
L. J. Reiter

January 15, 1984

Work Performed Under Contract No. AI01-76ET20356

Jet Propulsion Laboratory
California Institute of Technology
Pasadena, California

Technical Information Center
Office of Scientific and Technical Information
United States Department of Energy



DISCLAIMER

This report was prepared as an account of work sponsored by an agency of the United States Government. Neither the United States Government nor any agency Thereof, nor any of their employees, makes any warranty, express or implied, or assumes any legal liability or responsibility for the accuracy, completeness, or usefulness of any information, apparatus, product, or process disclosed, or represents that its use would not infringe privately owned rights. Reference herein to any specific commercial product, process, or service by trade name, trademark, manufacturer, or otherwise does not necessarily constitute or imply its endorsement, recommendation, or favoring by the United States Government or any agency thereof. The views and opinions of authors expressed herein do not necessarily state or reflect those of the United States Government or any agency thereof.

DISCLAIMER

Portions of this document may be illegible in electronic image products. Images are produced from the best available original document.

DISCLAIMER

This report was prepared as an account of work sponsored by an agency of the United States Government. Neither the United States Government nor any agency thereof, nor any of their employees, makes any warranty, express or implied, or assumes any legal liability or responsibility for the accuracy, completeness, or usefulness of any information, apparatus, product, or process disclosed, or represents that its use would not infringe privately owned rights. Reference herein to any specific commercial product, process, or service by trade name, trademark, manufacturer, or otherwise does not necessarily constitute or imply its endorsement, recommendation, or favoring by the United States Government or any agency thereof. The views and opinions of authors expressed herein do not necessarily state or reflect those of the United States Government or any agency thereof.

This report has been reproduced directly from the best available copy.

Available from the National Technical Information Service, U. S. Department of Commerce, Springfield, Virginia 22161.

Price: Printed Copy A06
Microfiche A01

Codes are used for pricing all publications. The code is determined by the number of pages in the publication. Information pertaining to the pricing codes can be found in the current issues of the following publications, which are generally available in most libraries: *Energy Research Abstracts (ERA)*; *Government Reports Announcements and Index (GRA and I)*; *Scientific and Technical Abstract Reports (STAR)*; and publication NTIS-PR-360 available from NTIS at the above address.

5220-22
Photovoltaic Program
Project Analysis and Integration Center

DOE/ET/20356-11
(DE84009746)
Distribution Category UC-63

Summary of Photovoltaic System Performance Models

J.H. Smith
L.J. Reiter

January 15, 1984

Prepared for
U.S. Department of Energy
Through an Agreement with
National Aeronautics and Space Administration
by
Jet Propulsion Laboratory
California Institute of Technology
Pasadena, California

JPL Publication 84-8

THIS PAGE
WAS INTENTIONALLY
LEFT BLANK

ABSTRACT

The purpose of this study is to provide a detailed overview of photovoltaics (PV) performance modeling capabilities that have been developed during recent years for analyzing PV system and component design and policy issues. A set of 10 performance models have been selected which span a representative range of capabilities from generalized first-order calculations to highly specialized electrical network simulations:

<u>Model</u>	<u>Name</u>	<u>Originator</u>
Engineering and Reliability	E&R*	Jet Propulsion Laboratory
Lifetime Cost and Performance	LCP	Jet Propulsion Laboratory
Photovoltaic F-CHART	PV F-CHART	University of Wisconsin Solar Energy Laboratory
Photovoltaic Performance Model	PVPM	Electric Power Research Institute
Photovoltaic Transient Analysis Program	PV-TAP	BDM Corporation/ Sandia National Laboratories
Solar Cell Model, Version 2	SOLCEL-II	Sandia National Laboratories
Solar Reliability	SOLREL	Battelle-Columbus Laboratories/ Sandia National Laboratories
Solar Energy System Analysis Program	SOLSYS	Sandia National Laboratories
Transient Simulation Program/ ASU version	TRNSYS/ASU*	University of Wisconsin Solar Energy Laboratories/ Arizona State University/ Sandia National Laboratories
Transient Simulation Program/ MIT version	TRNSYS/MIT*	University of Wisconsin Solar Energy Laboratories/ MIT Lincoln Laboratory

A set of performance modeling topics and characteristics is defined and used to examine some of the major issues associated with photovoltaic performance modeling. Next, each of the models is described in the context of these topics and characteristics to assess its purpose, approach, and level of detail. Then each of the issues is discussed in terms of the range of model capabilities available and summarized in tabular form for quick reference. Finally, the models are grouped into categories to illustrate their purposes and perspectives.

*Acronyms for the purposes of this study.

ACKNOWLEDGMENT

We gratefully acknowledge the assistance of the following individuals who reviewed portions of the document and provided a wealth of detailed information on both the models and interpretation of the documentation:

<u>Name</u>	<u>Organization</u>
Chester Borden	Jet Propulsion Laboratory
Michael Edenburn	Sandia National Laboratories
Don Evans	Arizona State University
George Hart	Massachusetts Institute of Technology, Energy Laboratory
Edward Hoover	Sandia National Laboratories
Sanford Klein	University of Wisconsin, Madison Solar Energy Laboratory
Timothy Lambariski	The BDM Corporation
Ronald Ross/Charles Gonzalez	Jet Propulsion Laboratory
Lawrence Stember	Battelle Laboratories
Roger Taylor	Electric Power Research Institute

We also wish to thank Chester Borden and Jeffrey L. Smith for their valuable suggestions and faithful support of this project. We would also like to thank Dottie Johnson and Fran Mulvehill for their patience in typing the manuscript.

The work in this report was performed through NASA Task RE-152, Amendment 200, DOE/NASA Interagency Agreement No. DE-AI01-76ET20356.

CONTENTS

I.	EXECUTIVE SUMMARY	1-1
II.	INTRODUCTION	2-1
	A. INTRODUCTION	2-1
	B. PURPOSE AND SCOPE	2-1
	C. MODEL SELECTION	2-3
III.	METHODOLOGY	3-1
IV.	MODEL REVIEWS	4-1
	A. ENGINEERING AND RELIABILITY MODEL (E&R)	4-1
	B. LIFETIME COST AND PERFORMANCE MODEL (LCP)	4-7
	C. PHOTOVOLTAIC F-CHART MODEL (PV F-CHART)	4-12
	D. PHOTOVOLTAIC PERFORMANCE MODEL (PVPM)	4-17
	E. PHOTOVOLTAIC TRANSIENT ANALYSIS PROGRAM (PV-TAP)	4-21
	F. SOLAR CELL MODEL, VERSION II (SOLCEL-II)	4-30
	G. SOLAR RELIABILITY MODEL (SOLREL)	4-33
	H. SOLAR ENERGY SYSTEMS ANALYSIS MODEL (SOLSYS)	4-36
	I. TRANSIENT SIMULATION PROGRAM--ASU VERSION (TRNSYS/ASU)	4-41
	J. TRANSIENT SIMULATION PROGRAM--MIT VERSION (TRNSYS/MIT)	4-45
V.	SUMMARY OF MODEL CAPABILITIES AND LIMITATIONS	5-1
	A. MODEL CAPABILITIES: ISSUES ADDRESSED	5-1
	B. MODEL LIMITATIONS: RECENT EXTENSIONS AND OPEN TOPICS	5-12
	C. SUMMARY OF MODEL GROUPINGS	5-16
	D. VALIDATION	5-18
VI.	DISCUSSION AND CONCLUSIONS	6-1

VII. REFERENCES	7-1
---------------------------	-----

APPENDIX: OBTAINING THE MODELS	A-1
--	-----

Figures

4-1. Engineering and Reliability Model Structure	4-2
4-2. Lifetime Cost and Performance Model Structure	4-8
4-3. Photovoltaic F-Chart Model Structure	4-13
4-4. Photovoltaic Performance Model Structure	4-19
4-5. Typical Photovoltaic Transient Analysis Program Structure: Array With One Panel Identified Separately	4-22
4-6. Example of Flat-Plate PV Cell Thermal Model Electrical Analysis	4-24
4-7. Solar Cell Model, Version II, Model Configuration	4-30
4-8a. Overview of Interactions of Availability Methodology with the System Design Process	4-34
4-8b. Flowchart for Simulation Program - SOLREL	4-34
4-9. Solar Energy Systems Analysis Model Structure	4-38
4-10. Sample Transient Simulation Program (ASU Version) Structure	4-42
4-11. Transient Simulation Program (MIT Version) Framework	4-46

Tables

1-1. Summary of PV Performance Models	1-3
3-1. Photovoltaic Performance Modeling Topics and Attributes	3-2
4-1. Photovoltaic F-CHART Array Model Inputs	4-15
4-2. Photovoltaic Transient Analysis Program Cell Model Inputs	4-25
5-1. Model Capabilities: Cell Characteristics	5-2
5-2. Model Capabilities: Module Characteristics	5-4
5-3. Model Capabilities: Orientation and Geometric Characteristics	5-5

5-4.	Model Capabilities: Array-Level Characteristics	5-7
5-5.	Model Capabilities: Power Conditioning Unit Characteristics	5-8
5-6.	Model Capabilities: Plant-Level Characteristics	5-10
5-7.	Model Capabilities: Operations and Maintenance Characteristics	5-11
5-8.	Model Capabilities: Site-Specific Characteristics	5-13
5-9.	Summary of PV Performance Models	5-17

SECTION I

EXECUTIVE SUMMARY

The study of photovoltaic (PV) technologies has been accompanied by the development of numerous models which have been used for a wide range of policy studies, design analyses (both detailed and system level), and economic analyses. The proliferation of these models has led to a broad set of capabilities which can be used to characterize PV systems. Because of the rapid evolution of PV technology and extensive empirical data from PV installations, PV computer codes and documentation have struggled to keep pace with developments. This study was conceived as a way of providing a detailed picture of the range of model capabilities, the analytical approaches available, and a characterization of the perspectives and purposes of the models, both individually and as a group.

Because of the varying purposes for which available models were developed, it is difficult to conduct numerical comparisons. A common quantitative basis for comparison could yield misleading results. A qualitative approach was used, therefore, to provide a way of examining a diverse set of models on a uniform basis. The following objectives summarize the approach of this study.

The first objective was to develop a representative taxonomy of PV performance modeling topics and attributes. The issue of interest was how to model PV performance at the subsystem and system level. This issue was examined by topic area corresponding to the characteristics of PV systems. The major topics are Cell-Level, Module-Level, Array-Level, Orientation and Geometry, Power Conditioning, Plant-Level, Operations and Maintenance, and Site-Specific Characteristics. These topics and the specific attributes within these topics are defined in greater detail in Section III. It should be noted that an iterative approach was used to define these topics and the attributes within each topic area. A candidate set of topics was developed and then revised when the models were selected. The list was expanded to incorporate the range of capabilities inherent in the models. In this sense, the models examined defined the basis on which they were reviewed.

The second objective was to identify and review a comprehensive sample of the major models according to their degree of usage by the PV modeling community in general; their usage as a policy tool by National Laboratories; their usage as a tool for system design and performance studies reported in the literature; and availability of documentation on the model. The following models were selected for review and represent a complete set of available models based on the stated purposes of the study and present documentation (some of the acronyms were developed for use in this study):

<u>Model</u>	<u>Name</u>	<u>Originator</u>
Engineering and Reliability	E&R ¹	Jet Propulsion Laboratory
Lifetime Cost and Performance	LCP	Jet Propulsion Laboratory
Photovoltaic F-CHART	PV F-CHART	University of Wisconsin Solar Energy Laboratory
Photovoltaic Performance Model	PVPM	Electric Power Research Institute
Photovoltaic Transient Analysis Program	PV-TAP	BDM Corporation/ Sandia National Laboratories
Solar Cell Model, Version 2	SOLCEL-II	Sandia National Laboratories
Solar Reliability	SOLREL	Battelle-Columbus Laboratories/ Sandia National Laboratories
Solar Energy System Analysis Program	SOLSYS	Sandia National Laboratories
Transient Simulation Program/ ASU version	TRNSYS/ASU ¹	University of Wisconsin Solar Energy Laboratories/ Arizona State University/ Sandia National Laboratories
Transient Simulation Program/ MIT version	TRNSYS/MIT ¹	University of Wisconsin Solar Energy Laboratories/ MIT Lincoln Laboratory

Section IV provides detailed reviews of each model in terms of the topics and attributes defined in the first objective. The approach for reviewing the models involved a topic-by-topic, attribute-by-attribute examination of each model to identify whether the performance attribute was: (1) characterized by an analytic model (e.g., a shadow model for calculating inter-array shading on a time-of-day basis); (2) modeled externally and the results input by the user (e.g., a fixed percentage loss for shadowing); or (3) not addressed.

The third objective was an attempt to determine the areas of modeling emphasis of each model, using the review summarized above. Section V-C provides further information on how these groupings were selected. Table 1-1 summarizes and groups the emphasis of each model. Section IV of this report provides a topic-by-topic review of each model, which is summarized in Tables 5-1 through 5-8. In addition, an appendix is included to provide potential users with points of contact for obtaining those models that are available to the public.

The fourth objective was to document the variety of approaches implemented by the various models. The present study provides such documentation.

¹Acronyms for the purposes of this study.

Table 1-1. Summary of PV Performance Models

Category	Model	Summary	
Simplified First-Order	PV F-CHART	The model is straightforward (interactive) and provides useful information as a first-order performance and economic calculation based on long-term averages for fixed, flat-plate PV systems.	
	PVPM	A first-order performance calculation based on the product of array area, subsystem efficiencies, temperature-dependent array efficiency, and insolation.	
Detailed PV System Performance ^a Module/Array Flat-Plate	E&R	A set of computer elements linked together to perform detailed system performance studies including effects of mismatch, cell failure, and alternative design strategies.	
	LCP	A system-level model for flat-plate array design and performance trade-offs, and system operation over time including performance and cost impacts of mismatch, shading, cell failure and replacement, dirt accumulation and cleaning, and maintenance.	
	TRNSYS/MIT	A detailed thermal and electrical model of a solar array for residential PV systems.	
Cell/Concentrator	SOLCEL-II	A detailed thermal and electrical model of a solar cell extended to the system level by multiplication of insolation, efficiencies, and area (to perform design optimization and life-cycle cost studies).	
	SOLSYS	A detailed thermal and electrical performance model of a solar cell extended to the system level by multiplication of insolation, efficiencies, and area.	
	TRNSYS/ASU	A detailed thermal and electrical model of a solar cell extended to the system level by multiplication of insolation, efficiencies (e.g., power conditioning), and area.	
Special Cases	Detailed Electrical	PV-TAP	A detailed, descriptive model of PV electrical networks for the parametric analysis of transient responses in electrical networks and electrical design trade-offs.
	Detailed Reliability	SOLREL	A reliability and availability analysis model for PV-analysis modeling systems that allows the user to keep track of system failures, downtime, maintenance costs, and energy output.

^aSubdivided by technology emphasis although the concentrator models can also model flat-plate systems.

The fifth objective was to identify areas of recent extensions or future research which are of interest. There have been extensions to evaluate Fresnel refraction of the module encapsulant and anisotropic diffuse atmospheres (E&R, LCP) as well as studies to examine the effects of varying time-steps on PV performance estimates (TRNSYS/MIT). The effects of cell spectral response have been incorporated in the E&R model. In addition to these extensions in the fifth objective, there are a number of areas that may be characterized as "open issues." These include the issue of input data quality (particularly insolation): whether we need better models or better input data; replication of the same annual insolation profile over the system life; modeling the quality of PV power output versus utility grid interconnect requirements; and the effects of partial array shading on performance.

For the set of models reviewed in this study, the following major conclusions have been drawn from this study:

- (1) There are a wide variety of PV performance models which have provided and continue to provide useful contributions to photovoltaic research and development.
- (2) Each model was developed with a purpose in mind. The purpose of the model is important because the use of these models outside the range of their intended application could lead to questionable results.
- (3) Because of varying purposes, the models address PV performance issues characterized at different levels of detail (complexity). Furthermore, simplicity does not imply that a model is relatively less useful.
- (4) Many of the above models have been validated for specific applications and there are some baselines of agreement among models.
- (5) A major problem is the need for better quality input data. This outweighs the need for developing new models at this time although refinements can certainly be made to existing models as more data and PV alternatives become available. (The SOLREL model is an example of a refinement; see Section IV-G.)
- (6) A number of recent extensions to specific models have been incorporated or examined, including:
 - (a) Fresnel refraction by encapsulant material (E&R, LCP).
 - (b) Effects of using simulation time scales other than one hour (TRNSYS/MIT).
 - (c) Modeling of anisotropic atmosphere for diffuse solar radiation component (E&R and LCP).
 - (d) Effects of insolation spectral distribution on power output (E&R).

- (7) There are a number of areas that appear to be open modeling questions which have not been covered well by the models reviewed:
- (a) The effects of insolation variability on PV system performance. Specifically, the kinds of data that are necessary for such studies in terms of timestep, form, and quality need to be identified.
 - (b) Modeling quality of PV power output versus utility grid interconnect requirements.
 - (c) Effects of partial shading of arrays on performance (linear assumption of 10% shading = 10% power loss and end effects). A related problem is the estimation of shadow losses for different collector options and shapes.

SECTION II

INTRODUCTION

A. INTRODUCTION

The study of photovoltaic (PV) technologies has been accompanied by the development of numerous models which have been used for a wide range of policy studies, design analyses (both detailed and system level), and economic analyses. The proliferation of these models has led to a broad set of capabilities which can be used to characterize PV systems. Because of the rapid evolution of PV technology and empirical data from PV installations, PV computer codes and documentation have struggled to keep pace with developments. This study was conceived as a way of providing a detailed picture of the range of model capabilities, the analytical approaches available, and a characterization of the perspectives and purposes of the models, both individually and as a group.

Five objectives were identified to achieve this purpose. The first objective was to identify a representative taxonomy of PV performance modeling topics and attributes to facilitate the review of models. These topics and attributes are defined in detail in Section III. The second objective was to identify and review a comprehensive sample of the major models according to a number of criteria which are defined in Section II.C. The third objective was to determine the emphasis of each model (see Section V-A, V-C) based on the detailed reviews which may be found in Section IV. The fourth objective was to document the variety of approaches implemented by the various models. Finally, the fifth objective was to identify areas of recent extensions and future work. These topics are discussed in Section V-B.

B. PURPOSE AND SCOPE

The purpose of this study is to provide an in-depth summary description and comparison of the capabilities of various PV performance models. To facilitate the review of these models, a set of candidate topics and attributes are proposed as a taxonomy for characterizing the range of PV performance models. The major modeling characteristics have been identified across both subsystem and functional components so that each topic is addressed at both the relevant subsystem level and the functional capability which it performs. However, it is recognized that such a categorization requires flexibility. The models have been described across a number of planes: level of detail; original purpose; functional capabilities; and capabilities not specifically contained in the list of topics and attributes used in this report (such as economic modeling). By using such a structured approach, the likelihood of missing important capabilities is reduced. The aim is not to validate the accuracy or appropriateness of a particular model approach but to present, in a structured fashion, the capabilities and design characteristics of the model itself. In some cases, the models possess a broad and expansive menu of capabilities. For the purposes of this task, the following ground rules were observed in critically examining the models chosen for this study:

- (1) The emphasis is on modeling of PV system electrical performance.
- (2) Economic elements are not considered in detail.
- (3) Electrical storage is not examined in detail.
- (4) A numerical comparison is not performed.

A list of models was compiled according to a stated set of criteria and their documentation was reviewed to limit any duplication of the models. The final list of 10 models represents a broad array of organizations, approaches to modeling, and perceived needs.

This review does not attempt to validate these models but aims to provide details on a variety of approaches to PV performance modeling issues. Although aspects of PV subsystem simulation can be modeled in similar ways, one finds that some subsystems are modeled in greater detail than others. It was found during the course of this study that considerable confusion exists in terms of the general level of understanding of these models and their capabilities. Terms such as "insolation inputs," "PV performance models," and "cell temperature model," are used freely to characterize these models. However, the varied approaches used to model these phenomena reveal a variety of different approaches to modeling. Some are purely descriptive models, others are prescriptive in emphasis (some are both). Some of the computer implementations of the models have highly integrated frameworks while others are highly modular with very little integration. Some of the models require few inputs while others require massive input data sets.

These differences can usually be traced to the original purpose of the model development. Thus, in models emphasizing cell- or module-level detail (physics in some cases), these aspects may be modeled very specifically whereas the array- or systems-level elements are simplified. Similarly, the reverse also occurs--models that emphasize system performance may simplify the cell and module level models.

This "selective" emphasis of particular elements of the model is usually based on the developer's interest in relative performance of the overall system and a desire to examine the effects of alternative subsystems in a particular area. Because the emphasis is strongly related to the purpose of the model development, this study attempts to identify clearly these purposes.

This study was also undertaken to provide documentation of the level of model development in the National Photovoltaics Program. While there are extensive documentation, listings, and model summaries available for the individual models, there existed a need for identifying models and describing issues on a consistent basis. An objective of this effort was to provide such documentation in the form of a "snapshot" of current PV performance modeling capabilities.

The aim of this study is not to select preferred PV performance models or judge these models using any criterion of validity. Rather, the purpose is to identify the span of issues addressed by the models, illustrate the extent to which the models attempt to evaluate the issues, and group the models according to model intent. The purpose here is to show the selective emphasis or purpose of each model in a clearer light. With this objective in mind, no a

priori judgment is made that incorporation of more analytical detail results in a "better" model.

The issue of what makes one model preferable to another, or gives it greater validity, coupled with the diversity of model approaches, is an indicator that comparisons based on classical validity tests are difficult, if not impossible, at this time. Nonetheless, some attempts have been made by model developers and users to validate these models with empirical data. These attempts reveal that, for the most part, the models provide useful results for their intended applications. A brief discussion on the issue of validation is presented in Section V-D.

The methodology is presented in Section III and detailed reviews in Section IV. Section V examines the capabilities and limitations of the models examined and attempts to summarize the models. This is followed by a discussion and presentation of conclusions in Section VI.

C. MODEL SELECTION

The models reviewed in this study span a historical period from the early 1960s through the present. Many of the detailed cell-level models were developed originally for PV applications such as spaceborne power systems. For terrestrial PV systems, most of the development effort took place from the mid-1970s to the present; and additional work is still ongoing.

This section presents a list and brief overview of the PV system performance models to be summarized and reviewed. During the course of recent years numerous PV models, algorithms, and methodologies have been developed as aids in various research and development areas including policy-making work, design studies of subsystem and system components, and system sizing studies. There are numerous models available for PV performance analysis. For a comprehensive list of models see Solar Energy Research Institute, 1980; and S. Grundstrum, personal communication, 1983. The list of models chosen for the present study and their originators is shown below:

<u>Model</u>	<u>Originator</u>
E&R	Jet Propulsion Laboratory
LCP	Jet Propulsion Laboratory
PV F-CHART	University of Wisconsin Solar Energy Laboratory
PVPM	Electric Power Research Institute
PV-TAP	BDM Corporation/ Sandia National Laboratories
SOLCEL-II	Sandia National Laboratories
SOLREL	Battelle-Columbus Laboratories/ Sandia National Laboratories

<u>Model</u>	<u>Originator</u>
SOLSYS	Sandia National Laboratories
TRNSYS/ASU	University of Wisconsin Solar Energy Laboratory/ Arizona State University/ Sandia National Laboratories
TRNSYS/MIT	University of Wisconsin Solar Energy Laboratory/ MIT Lincoln Laboratory

The models were selected based on the following criteria:

- (1) Degree of usage by PV community in general.
- (2) Usage as a tool for policy analysis by National Laboratories.
- (3) Usage as a tool for system design and performance studies reported in the literature.
- (4) Availability of model documentation.

Although numerous models exist in the literature, many are proprietary, undocumented, no longer in use, or have been modified to such an extent that the present version of the model and the original documentation are not compatible. This reduces the number of models available for review.

The Solar Energy Research Institute (SERI) is using a module optimization methodology (PVMOC) for module design analysis (Collaros, et al., 1982). Because the emphasis of the present study is on systems-level models, PVMOC was not included. SERI is also using versions of PV-TAP for their detailed analyses and SOLCEL for systems analysis (DeBlasio, et al., 1983, personal communication). This was also the case with Boeing Corporation's SIMWEST model, which is a modified version of the SOLCEL program (Warren et al., 1979). A model developed by Aerospace Corporation (Leonard, et al., 1977) is also omitted from this review because their model is no longer supported (Leonard and Simberger, personal communication, 1983). Another observation made during the review of these models is that some have been dropped or utilized less because of large computational costs (and reduced computer budgets) and/or removal of large mainframe equipment from the organization (as in SERI's case). The E&R, LCP, and PV F-Chart models are now (or will soon be) operating on microcomputers and the remaining codes run on mainframes.

These models are described in detail in Section IV to characterize their analytical capabilities. Those reviews provide a discussion of model capabilities based on available documentation and discussions with the model developers. It is not an assessment of the validity of the model approaches. The available documentation serves as the focal point for the comparison; every effort has been made to note any significant changes. Additional details on the specific capabilities are described in Section V.

SECTION III

METHODOLOGY

This section describes the methodology used in the review of a number of PV performance models. The approach is qualitative in nature. Performance model capabilities will be characterized by eight major topic areas: (1) cell characteristics; (2) module characteristics; (3) orientation and geometric characteristics; (4) array-level characteristics; (5) power conditioning unit (PCU) level characteristics; (6) plant-level characteristics; (7) operations and maintenance characteristics; and (8) site-specific characteristics. The characteristics identified under each major area provide a basis for describing technical approaches and identifying PV performance modeling issues. The scope of this initial study was to summarize the models and their approaches, so numerical comparisons were not performed. Future efforts may, however, include such comparisons.

An initial list of topics and attributes was defined and, after the models were selected, the list was revised to reflect the individual characteristics of the models to be examined. This iterative approach led to a list of topics, and particularly, attributes, that were defined by the models reviewed (Table 3-1). In this sense, the list of topics and attributes defines the range of model capabilities.

For the topics and performance modeling attributes identified in this Section, each of the models was examined to identify whether:

- (1) The models contain an analytic characterization of the topic to be modeled (i.e., they address the topic by modeling it).
- (2) The models address the topic by externally determining the result (e.g., the element is approximated by some user-input value(s)).
- (3) The models do not address the topic (i.e., they do not attempt to simulate the element).

For the selected set of models (see Section II), the following major topics and attributes were identified:

Cell and Module Characteristics: Those elements primarily associated with specification of the cell and module in terms of power output and performance as a function of design (see Table 3-1). The following attributes were included for the cell level:

Cell I-V curve: How is the characteristic current-voltage curve associated with any PV cell modeled (or input)?

Cell mismatch: How are losses due to dissimilar voltages or currents between cells handled?

Cell failure: How are cell failures and reliability addressed?

Table 3-1. Photovoltaic Performance Modeling Topics and Attributes

Topics	Attributes
Cell	Cell current-voltage curve Cell mismatch Cell failure Cell temperature
Module	Series/parallel specification Bypass diodes Module mismatch Module failure Module encapsulant refraction Module degradation
Orientation and Geometric	Flat plate: (fixed-tilt, two-axis, one axis N/S, E/W, vertical axis tracking) Concentrators: (two-axis Fresnel lens, N/S trough, E/W trough, compound parabolic trough) Adjustable tilt for fixed arrays User-specified array-tracking startup and shutdown times
Array-level	Series/parallel specification Array electrical mismatch Shading
Power Conditioning Unit	Voltage control Maximum power tracking Fixed voltage Floating battery Multiple inverters Form of PCU calculation (efficiency a function of load or constant multiplier)
Plant-level	Balance of system Utility load/interconnect Battery storage
Operations and Maintenance	Cleaning Reliability Module replacements O/M costing
Site-Specific	Total global radiation Direct normal radiation Diffuse solar radiation Atmospheric type Method of calculation Ground reflectivity Ambient temperature Other environmental variables Load data Solar/local time correction Time-dependent dirt accumulation

Cell temperature: How is the cell temperature calculated from insolation, air temperature, etc.?

For the module level, the categories addressed were:

Series/parallel specification: How is the wiring design of the module handled in the model?

Bypass diodes: How are bypass diodes taken into account?

Module mismatch: Similar to cell mismatch above?

Module failure: Similar to cell failures above?

Module encapsulant refraction: How does the module simulate the bending of incoming radiation due to the encapsulant?

Module degradation: How are the various mechanisms which gradually degrade module performance modeled?

Orientation and Geometric Characteristics: This category considers those elements which involve the geometric relationships between the collector surface and the incoming solar radiation. The topics are grouped by their relevance to flat-plate or to concentrator systems.

Flat-Plate Systems

Fixed tilt: How is solar radiation obtained for a fixed, tilted array surface at specified azimuth angle?

Two-axis tracking: How is solar radiation obtained for a two-axis tracking array surface tracking the sun at each timestep?

North/south axis tracking: How is solar radiation obtained for a one-axis tracking array surface tracking the sun about a north/south axis (either horizontally or tilted)?

East/west axis tracking: How is solar radiation obtained for a one-axis tracking array surface tracking the sun about an east/west axis?

Vertical axis tracking: How is solar radiation obtained for a one-axis tracking array surface tracking the sun about a vertical pole?

Concentration Systems

Two-axis Fresnel lens: How is the concentration of solar radiation through a two-axis tracking Fresnel lens performed?

East/west linear trough: How is the concentration of solar radiation by an east/west linear trough performed?

North/south linear trough: How is the concentration of solar radiation by north/south linear trough performed?

Compound parabolic trough: How is the concentration of solar radiation by a compound parabolic trough performed?

Adjustable tilt capability: How is the adjustment of fixed non-tracking arrays performed for monthly or seasonal energy maximization?

Variable start-up/shut-down times: How are different start-up and shut-down times handled for tracking systems (e.g., to minimize shadowing)?

Array-Level Characteristics: Those elements comprising an array configuration (an assembly of modules wired together). The items included were:

Series/parallel specification: Similar to module series/parallel specification.

Array mismatch: Similar to module mismatch.

Shading: How the model accounts for inter-array shading and its effects on array performance.

Power Conditioning Unit Characteristics: Those elements concerned with the manner in which power is converted from direct current to alternating current (if at all) and how the power level is maintained. The categories included are:

Voltage control: Does the model address any or all three of these methods of array voltage control: maximum power tracking, fixed voltage, or floating battery?

Multiple inverters: How does the model handle multiple inverters?

Plant-Level Characteristics: Those elements associated with groups of PCUs and other components comprising the overall power system. These elements include:

Balance of system: How are the losses due to the balance of system addressed?

Utility/load interconnect: How does the model handle the interaction between the PV system energy output, the load, and the utility (where applicable)?

Battery storage: How is battery storage, and its relation to load and utility connections, addressed?

Operations and Maintenance Characteristics: This category is comprised of those elements which involve operations and maintenance on the PV system to maintain or improve power output. These include:

Cleaning: How does the model allow for cleaning of the arrays? (See Site-Specificity for description of energy loss due to dirt accumulation.)

Reliability: How does the model analyze the availability or reliability of the PV system?

Module replacements: How does the model simulate the replacement of failed modules?

O&M costing: How does the model account for the costs associated with O&M activities?

Site-Specific Characteristics: Those elements which are unique to the location of the PV system. The categories included are:

Total global radiation: How does the model obtain or produce these data?

Direct normal radiation: How does the model obtain or produce these data?

Diffuse radiation: Does the model simulate different atmospheric types and, if so, how? How is ground reflectivity included?

Ambient temperature: How does the model obtain or produce these data?

Other environmental variables: What other variables are considered?

Load data: How does the model obtain or produce these data?

Solar/local time: Is the model able to operate on either solar time, local standard times, or both?

Time-dependent dirt accumulation: How does the model simulate energy losses due to dirt accumulation on the array surface?

Each of these topics is discussed for each of the selected models. Summary reviews are prepared in the format of Table 3-1. Draft copies of these reviews were sent to an author or co-author for each model to ensure that the available documentation had been interpreted correctly and to identify any new documents or applications. After the responses were collected and revisions made where appropriate, each model was assessed across all the topics (Section IV) and each topic was summarized across all of the models (Section V-A and Tables 5-1 through 5-8). Based on the detailed and summary reviews, each model is summarized briefly (Section V-C). The objective is to illustrate the selective emphasis of each model in accordance with one of the stated purposes of the study.

SECTION IV

MODEL REVIEWS

This Section reviews each of the 10 models with respect to the 8 topic areas presented in Section III. The format of Table 3-1 was used to describe each of the individual models. For some models, certain characteristics or attributes are not discussed because they were not addressed by the model. Such cases are noted in the text. A diagram of the model structure (from the model documentation in most cases) is included in each review. The models are listed in alphabetical order.

A. ENGINEERING AND RELIABILITY MODEL

The Engineering and Reliability (E&R) Model (acronym used for this study) has existed in a number of forms but most notably in an array performance model, a cell or module mismatch model, and a cell failure analysis model. The models are coded elements and intended for use as a flexible resource for examining PV design and performance topics. Because of this elemental approach, the codes are divided into a cell failure analysis model, a mismatch model, and the array performance model. The codes are not exportable because its primary purpose is to provide analytical support to the R&D activities within the Flat-Plate Solar Array (FSA) Program. Although it is not exportable, this model has been included here because it has formed the basis for several other models and has been used in a variety of significant analyses.

These analyses include the modeling of mismatch (JPL, 1980), cell failures, and cell degradation over time (Ross, 1978; Gonzalez and Weaver, 1980) among others. The emphasis of this review is on the array performance model (Ross, 1980a; Gonzalez et al., 1982; Gonzalez and Ross, 1983) which was designed to quantify the influence of various array design parameters on the array's annual energy output (see Figure 4-1). This simulation is performed on hour-by-hour integration of plane-of-the-array irradiance in conjunction with ambient temperature and other site-specific weather parameters. Although the term "array" performance is used here, the code is general in the sense that it aggregates current-voltage (I-V) curves according to the network of interest. The basic elements may be cells, modules, or arrays. Regardless of the element used, it is assumed the I-V curves are uniform and identical.

The following subsections summarize the details of the models.

1. Cell Characteristics

At the cell level, only the failure analysis and mismatch models are relevant because the array performance model begins at the array level. If the performance of cells is of interest, the user can input cell I-V curves and proceed as described under Array-Level Characteristics.

In addition to the E&R model, the cell failure model has been adopted in LCP, and to a lesser extent, SOLREL. The discussion of failures and the cell failure model is deferred to the subsection on reliability under the Operations and Maintenance heading.

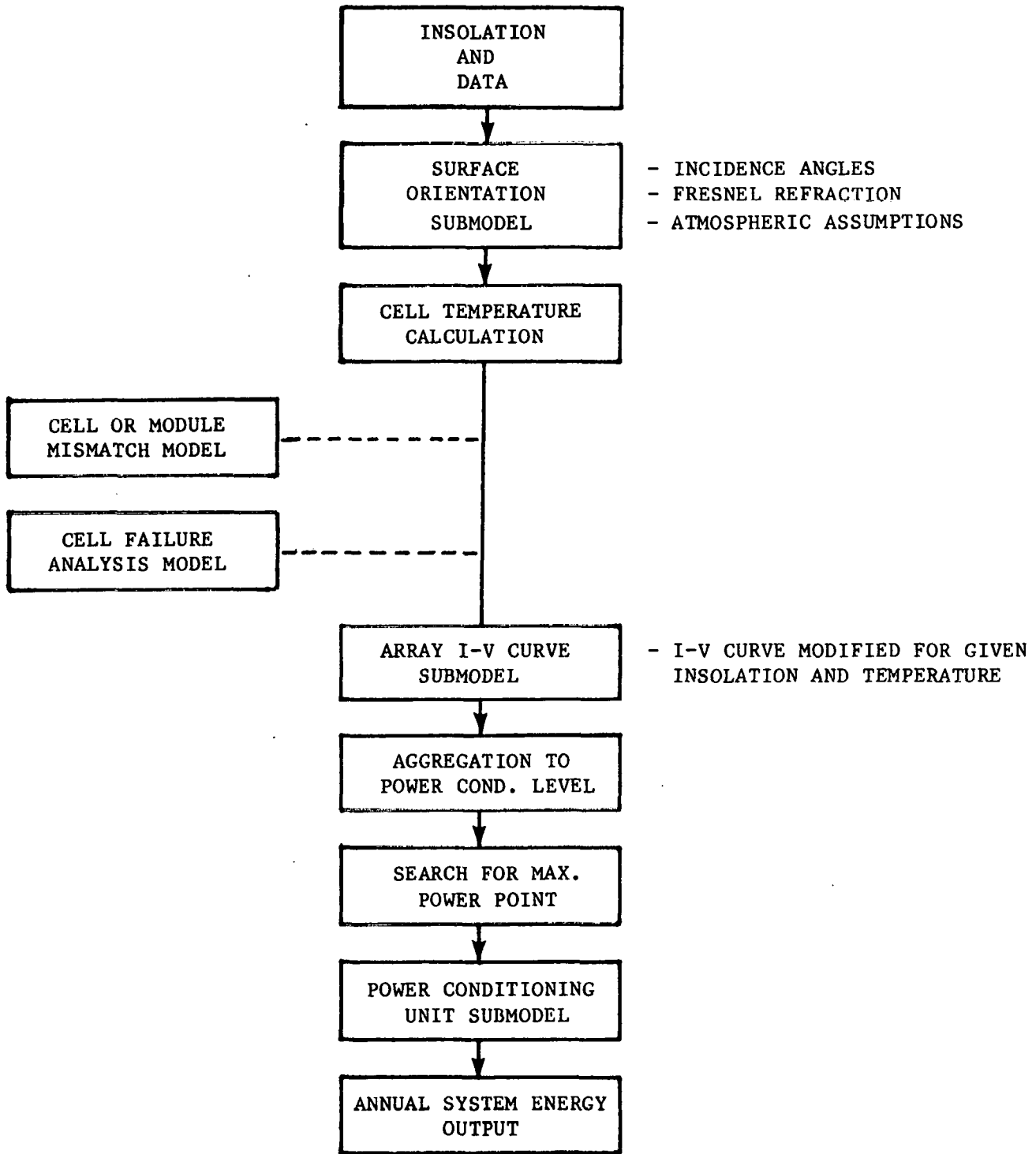

Figure 4-1. Engineering and Reliability Model Structure

The mismatch model can be applied to a series-parallel combination of cell or modules to calculate the loss of power from mismatch of electrical parameters characterizing individual I-V curves. These parameters include the short-circuit current, open-circuit voltage, shunt resistance, and cell fill factor of the cell I-V curve. The model uses either a specific set of values for each parameter set or a given statistical distribution of values. The series elements are added along lines of constant current and those in parallel are added along lines of constant voltage. The maximum power point of the resultant curve is compared to the average value using Monte Carlo techniques. This approach can also be performed at the module level using module level I-V curves.

The cell operating temperature is calculated from ambient temperature, wind speed (an option), and a module-specific nominal operating cell temperature (NOCT) parameter which characterizes its thermal performance. This calculation is used at the array (or module) level to represent the operating temperatures of those elements.

2. Module Characteristics

The series/parallel network of modules is specified in terms of the numbers of series and parallel elements. Module I-V curves would be input to characterize the module (i.e., all modules are equivalent in performance). Because the model is an array model, the discussion of the performance calculation is deferred to that subsection.

The effects of failures are described later under the cell failure model in the Operations and Maintenance subsection. Parameters from the series/parallel network up through the array level are used to estimate a power loss fraction, which is then applied to the idealized array power output. The model is capable of handling bypass diodes in the electrical design.

The model allows the user to examine the effects of Fresnel refraction of the solar beam through the module encapsulant material as an option. The equation of refraction through a single medium is used with a user input index of refraction for the encapsulant material. In addition, it is possible to include a factor accounting for increased optical losses from soiling (dirt accumulation) as the angle of incidence increases.

3. Orientation and Geometric Characteristics

The E&R performance model can simulate a number of different surface orientations, including the following flat-plate systems: fixed-tilt, any azimuth; north-south one-axis tracking (at any tilt angle); and two-axis tracking. The geometric relationships are derived from spherical trigonometry, and a general equation for the relationship between the sun incidence angle and the array surface is used. This equation is varied on an hourly basis in the case of tracking.

Because the E&R model was developed for the Flat-Plate Solar Array project at JPL, it does not model concentrating systems at this time. The model does have the capability to alter the fixed tilt values on a variable basis (such as monthly or seasonally).

4. Array-Level Characteristics

The array-power output is modeled as the product of hourly irradiance level and operating efficiency (which is a function of calculated cell operating temperature). The user can output total hours spent at a specific operating environment level over a given time period or (using another code element) an array I-V curve adjusted for specific insolation and temperature values for all the insolation cell-temperature pairs in the input data set providing an integrated total for the time period of interest (e.g., monthly or annual). After the cell operating temperatures are calculated from ambient air temperature and wind-speed data, a matrix of insolation and cell operating temperatures is used to generate the array-power output. Because a uniform I-V curve is used, this operation requires a minimum of multiplications. The maximum power point of the array is then found, and the entire procedure is repeated for each array in the system containing one bypass diode per series block of arrays.

Array shadowing is modeled in two of the orientation options: for fixed tilted arrays and north-south, one-axis trackers. The equations ignore end-effects (e.g., the partial shading that takes place at the end of the array where the shadow is not uniform) and assume that power loss is directly proportional to the fraction of the array covered by shadow. In both cases, the fraction of the array shaded is multiplied times the total power output at the array level. This assumption is common among the models reviewed here (see Section V-B under "Open Issues").

5. Power Conditioning Unit Characteristics

Extensive detail has been incorporated into this element of the E&R model because the model has been used to study various methods of power conditioning (Gonzalez, et al., 1982). The E&R model can simulate the following types of power conditioning:

- (1) Fixed-voltage operation (as a function of changing illumination level only).
- (2) Seasonally or infrequently adjusted constant voltage operation to account for seasonal temperature trends and/or array degradation.
- (3) Constant voltage operation with voltage updating based on frequent temperature sensing.
- (4) Continuous closed-loop feedback sensing of the power conditioning unit (PCU) output power to achieve continuous operation at the maximum power point.

In each of the above cases the model updates the PCU efficiency based on variations in key control variables that are site-specific, such as temperature or fill factor (as a function of temperature) and insolation. The model does not address floating batteries or multiple inverters.

6. Plant-Level Characteristics

The effects of balance-of-system losses are summarized in a user-input constant-power loss fraction due to parasitics. Capabilities such as utility load and grid interconnect models are not addressed because the primary purpose of the model is to examine design topics (at the module and array level). Battery storage is not addressed, due primarily to the focus of the model on flat-plate solar module or array design topics.

7. Operations and Maintenance

The current version of the E&R array performance model does not address module failures and degradation. These topics are examined separately, using a cell failure model. Because of the significance of the E&R model to contributions in the PV research and development area, a brief description of the cell failure model and its capabilities is presented.

The reliability component of the E&R model is a powerful tool for assessing the effects of different quality modules on system performance over its lifetime. Two cell failure modes are considered: open-circuit and short-circuit failures.

The first type of failure considered is that which results in the largest power loss: open circuit failures. A relationship is used that translates the cell failure probability density function and the number of cells per substring into a substring failure density. The cell failure density is derived from the cell failure rate (failures per year) and number of years of operation. An increase in the number of cells per substring for a fixed cell failure density results in an increase in the probability that a substring will fail. When a particular circuit design is to be analyzed, the number of cells per substring, the cell failure density, and the substrings per series block are specified. The number of substrings that fail within a series block governs the power output of the branch circuit and thus of the whole array. Using this approach, the state of failure of a branch circuit can be defined for any specific circuit design.

The results are used in the circuit simulation program to determine the power losses due to failures as a function of substring failure density. The array power loss is determined by summing the power losses for branch circuits having one failed substring, a maximum of two failed substrings, and so on. In the summation, each power loss is weighted by the fraction of branch circuits having series blocks (at least one) with a maximum of the corresponding number of failed substrings. In other words, this fraction of branch circuits will have series blocks with numbers of failed substrings up to and including the maximum. The result of this procedure is a family of I-V curves giving array power degradation as a function of the number of series blocks and parallel strings per branch circuit.

The PV cell is modeled using data describing the I-V curve shape. From a network description of the module, mismatch among cells is modeled by maintaining the characteristics of each cell. The program computes the I-V curve for each type of failure configuration. Starting with the substring I-V curve, the program adds along lines of constant voltage to obtain the series

block I-V curve for the given electrical design and number of failed series blocks. The I-V curve is scaled up to the array level to account for all the series blocks having a given type of failure configuration. The I-V curves of the series blocks with different failure configurations (including no failures) are added along lines of constant current to arrive at the source circuit I-V curve. The maximum power of a source circuit with failures is then compared to an ideal source circuit with no failures to obtain power loss.

The model can also simulate the effect of short-circuit failures. After maximum power voltage is determined at the array level, the branch circuit currents (array level) for each failure state at the array operating point are formed. The series block I-V curves for the various numbers of failures are then examined to find the corresponding voltage levels for each of the operating point currents.

Further details of this approach can be found in Gonzalez and Weaver, 1980, and JPL Document 5101-170, 1980.

8. Site-Specific Characteristics

The E&R model requires input of hourly total global and direct normal (for the two-axis tracking case) insolation for one year. The model can also use global horizontal insolation, site ephemeris data, and average sky conditions to calculate direct normal insolation using a modified Liu-Jordan (1960) technique to obtain radiation on the plane of the array. In either case, the three components of total radiation for the surface of interest are then calculated using the geometry for the surface orientation. The diffuse component can be calculated under two options--the assumption of isotropic (uniform scattering) or anisotropic (directional scattering from circumsolar, horizon, and ground components) atmospheres (Klucher, 1979). There is a user input parameter to characterize the ground-reflected-insolation component in the total calculation. An additional model element can be used with a spectral radiation program to calculate the spectral composition of solar radiation for each hour. The results of this calculation are multiplied by the array cell spectral characteristics (response) to obtain the fraction of radiation contributing to array output.

The model also requires an hourly ambient temperature and wind-speed profile over a year, which is used in the cell temperature calculation.

The model can operate in either solar or local time, depending on the requirements of the user. The model uses an equation of time (ephemeris) and an adjustment for local longitude position in the Standard time zone.

The above models serve primarily as a test bench for examining specific array design topics. The array performance model is generally used to conduct annual simulations based on hourly weather conditions. Results are displayed as a histogram of power output level versus number of hours per year at that level.

The program is written in FORTRAN for UNIVAC mainframe equipment. In addition, some portions of the code have recently been extended to operate on microcomputer hardware.

The model can be summarized as a set of computer elements that are linked together as required to perform detailed system level parametric simulations of various PV subsystems and their aggregate performance.

B. LIFETIME COST AND PERFORMANCE MODEL (LCP)

LCP was developed at JPL to provide an analytical structure for relating a comprehensive set of technical and economic factors to the resulting stream of PV system performance, cost, and dollar value over the system lifetime (Borden, 1981, and Figure 4-2). The model of PV system performance in LCP focuses on the array level for system modeling although fairly detailed degradation and failure analysis capabilities do exist at the cell and module level.

The approach taken by LCP emphasizes performance and cost over the life of the system. The hourly PV performance model for non-degraded PV system operations for a single year resembles several of the other models described in this report. LCP then incorporates the effects of degradation over the PV system lifetime because various mechanisms and site-specific characteristics, which are modeled in detail. The model also allows for operations and maintenance activities to be performed and accounts for their effect on performance and cost.

The most recent LCP version is written in Basic for microcomputers. The model consists of a number of modular sub-programs that may be run separately (Davisson, et al., 1983). As a unit they comprise an integrated analysis of photovoltaic system performance and cost.

1. Cell Characteristics

LCP focuses on the array level for performance modeling, but degradation and failure effects are examined in detail at the cell level, based on an extended version of the E&R reliability model described earlier (Gonzalez and Weaver, 1980). The cell I-V curve is input to the model as a piecewise linear fit consisting of up to 25 pairs of I-V points. This curve is the basic building block of the degradation model. Cell failures occur stochastically based on a failure rate input by the user. I-V curves for the block of cells in series, the module, the branch circuit, and the array are all determined based upon the aggregation of the cell I-V curves. See the operations and maintenance section for the details of this method.

The temperature of the cell is modeled via a linear relationship between ambient air temperature, insolation, and rate of change of cell temperature with respect to insolation. Module efficiency estimates are corrected for the difference between cell temperature at any point in time and the cell temperature under a specified set of standardized conditions. The module temperature is assumed to be the cell temperature for this calculation.

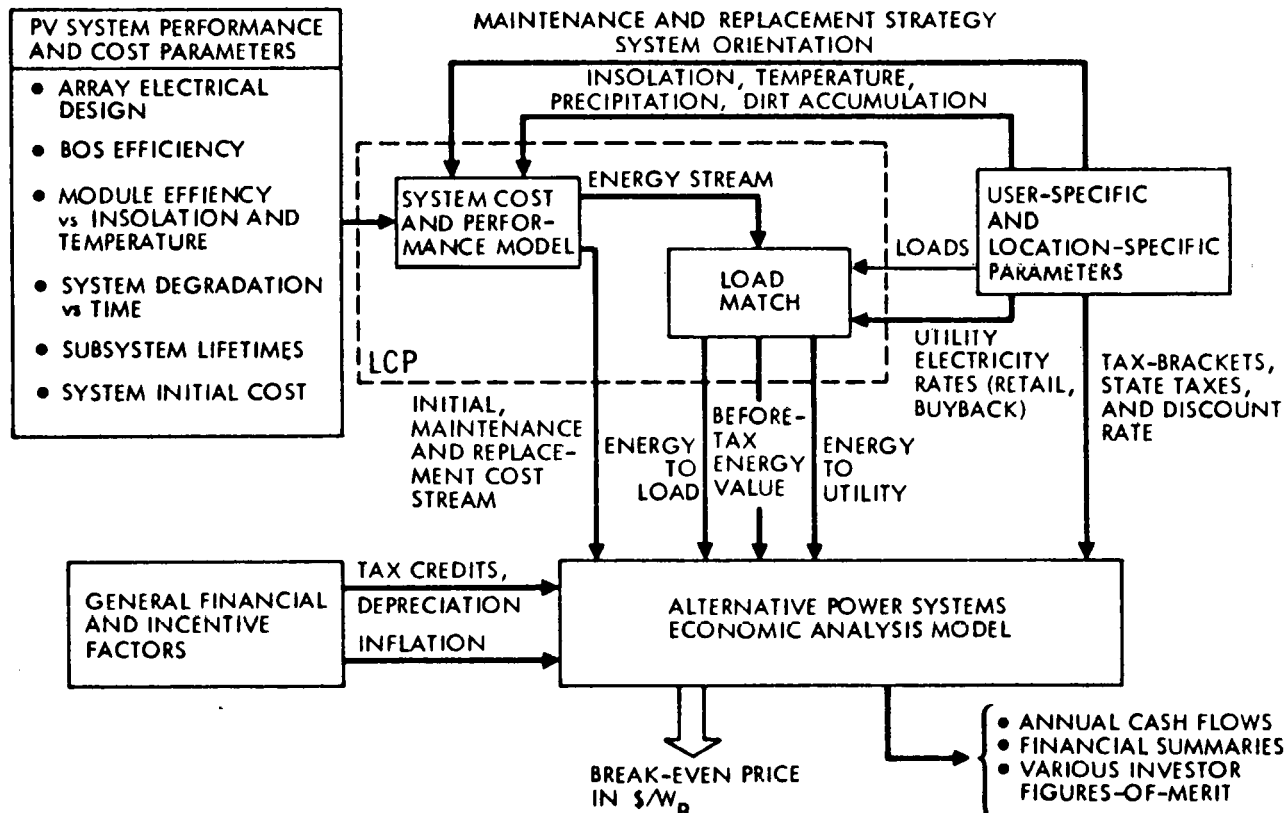

Figure 4-2. Lifetime Cost and Performance Model Structure. The elements within the dashed lines represent the LCP model (Source: Borden, 1981)

These formulae are used in LCP as well as in several of the other models described in this report (i.e., E&R, PV F-CHART, PVPM):

$$\begin{aligned}T_{\text{cell}} &= T_{\text{amb}} + mS \\ \text{EFF}_{\text{module}} &= \text{EFF}_{\text{ref}} [1 - C(T_{\text{cell}} - T_{\text{ref}})]\end{aligned}$$

where:

$$\begin{aligned}T_{\text{cell}} &= \text{cell temperature} \\ T_{\text{amb}} &= \text{ambient temperature} \\ m &= \text{insolation-temperature coefficient} \\ S &= \text{incident insolation} \\ \text{EFF}_{\text{module}} &= \text{operating module efficiency} \\ \text{EFF}_{\text{ref}} &= \text{reference module efficiency} \\ C &= \text{temperature-efficiency coefficient} \\ T_{\text{ref}} &= \text{reference cell temperature}\end{aligned}$$

2. Module Characteristics

LCP differentiates between the cell and module level by taking into account encapsulant refraction, module degradation, module failure, and the interior wiring design of the module.

The model is capable of modeling Fresnel encapsulant refraction based on panel orientation and position and including the results in the geometric modeling described below. Standard formulations for Fresnel refraction are used (similar to those in TRNSYS/ASU and E&R). The index of refraction of the encapsulant is a user input to the model.

LCP contains two options for module degradation: either a simple exponential decay model or an in-depth module-level model based on the cell I-V curves. For the former method, the user simply defines the yearly degradation rate for the exponential decay of annual PV system performance. The latter method includes the cell failures from the cell model (see above) within the system arrangement of series/parallel connections and bypass diodes. See the section on operation and maintenance for the details of this method.

3. Orientation and Geometric Characteristics

LCP contains nine orientation options for fixed and tracking flat-plate collectors. Concentrators are not addressed at this time. The fixed options include: fixed at any azimuth and any tilt, horizontal fixed, monthly defined tilt and azimuth angle, south facing with monthly optimized tilt. "Optimized" is defined here to mean the orientation yielding the maximum annual insolation received at the collector surface. Tracking options include: horizontal east-west axis tracking, horizontal north-south axis tracking, tilted north-south axis tracking, tracking about a polar axis with an optimized tilt (same definition of optimal as above), and two-axis tracking. In addition, the user may define tracking limit angles for the one-axis trackers. For the cases with monthly-varying conditions (e.g., array-tilt angles), the user defines a vector of inputs at the beginning of the simulation.

In each of these options, a geometric model determines the insolation arriving at the arrays. The model contains trigonometric relationships similar to those used in SOLCEL-II and SOLSYS. The non-degraded energy output calculated by this portion of the model is then modified to take into account factors that cause array performance to vary over its operating lifetime.

4. Array-Level Characteristics

The effects of row-to-row shading between arrays is included, based on the distance between rows and the width of the arrays. The model determines the amount of shading on the array by including the tilt and azimuth angles of the array at the particular point in time. The shading analysis is used for fixed arrays and one-axis tracking arrays, both with and without the tracking limit angle. Shading for two-axis trackers is not included at this time.

Once the shaded fraction of the array is calculated, energy output from the system is reduced accordingly. The temperature of the arrays is assumed to be unaffected by shading because the modules are assumed to be highly thermally conductive.

Array-level series/parallel wiring and electrical mismatch are modeled in a manner similar to that of the module level as part of an overall reliability analysis. See the Operations and Maintenance section for details.

5. Power Conditioning Unit Characteristics

The PCU efficiency curve is user input as a piecewise linear fit of pairs of part-load and full-load efficiencies. The model then interpolates to find the actual PCU efficiency for a given dc electrical output from the arrays. It is assumed that the power conditioning equipment maintains the array output at the maximum power point. Other modes of voltage regulation are not included. The PCU performance is assumed not to degrade over time, although PCU reliability and availability may be included in the yearly balance-of-system (BOS) downtime factor, which is input by the user (see Operations and Maintenance).

6. Plant-Level Characteristics

The remaining power output losses due to the BOS component are input by the user as a constant efficiency. This includes wiring, connections and parasitic losses. This efficiency is multiplied by the hourly PV system output.

The user may specify the connection to the utility, as appropriate. For a distributed, non-utility-owned PV system, this may either be a "simultaneous" connection, in which all PV power produced is sold to the utility and all demand is met by purchased power, or a "parallel" connection in which PV power output is preferentially used to satisfy the owner's demand and excess power is sold to the grid. A detailed cost and energy account is kept of purchased power versus power sold back to the utility, including rates and rate structures. In the case of utility ownership, all power is available to the

grid for dispatch to load. Dedicated battery storage for distributed and central-station systems is not included.

7. Operations and Maintenance

In LCP, operations and maintenance activities are included in two ways. The power output effects of dirt accumulation, cleanings, rains, aggregate array-level degradation, and system downtime for repairs or maintenance, are calculated in the performance model based on user inputs. The cost model keeps detailed accounts of various capital costs and expenses for operations and maintenance. These are discounted and escalated as appropriate to produce streams of dollar values for these costs as specified by the user. These outputs are in a format to be used as input to a life-cycle cost analysis.

The user defines the power reduction effects of dirt accumulating on the module surface, excluding the effects of cleaning, on a monthly basis (see "Site-Specific Characteristics" subsection.) Then the user specifies the number of manual cleanings for each month as well as the effectiveness of the cleaning in terms of array performance restoration. In addition, the number of rains for each month are user-defined along with their performance restoration level. A yearly system down-time factor (time-variable) is input by the user. This lost fraction of yearly operation accounts for failures, repairs, and maintenance of the various subsystems excluding the cells and modules, which are handled separately.

The modified version of the E&R reliability model keeps track of cell failures and their effect on modules, arrays, and system performance. The user inputs a cell failure rate, which is used in a stochastic model. The model calculates a probability of failure for the cell level and, based on that, a probability of failure for the substrings (cells in series) and the series blocks (substrings in parallel). Each of these probabilities is then used in a Monte Carlo simulation to produce I-V curves. These I-V curves for each unit are combined along constant voltage lines (for parallel circuits) or constant current lines (for series circuits) to produce an aggregate I-V curve for the next level. Modules are made up of series-blocks in series and branch circuits that operate at the PCU voltage level. The final result is an I-V curve for the array. In this fashion the module simulates the system degradation due to cell failures on a month-by-month basis.

There are two strategies available in the model-for-module replacement. Failed modules, defined by a user-specified number of substrings that have failed, are either replaced as they occur on a month-by-month basis, or they are replaced when the array power falls below a user-specified, minimum level. In this latter case modules are replaced, beginning with the worst ones, until another user-specified array power restoration level is reached.

8. Site-Specific Characteristics

LCP accepts insolation data in the form of total global horizontal insolation, direct normal insolation, and ambient air temperature data. (If no data for direct normal insolation exists, LCP uses a model developed by Sandia National Laboratories to estimate direct normal values from the total

global radiation (Boes, et al., 1976). The model allows the user to input a "units conversion factor," if needed, so that data in units of kJ or kW/m² may be used. The diffuse radiation component of the total global insolation is calculated using a modified Liu and Jordan (1960) model, based on the total global and direct normal insolation data. Either isotropic (uniform scattering) or anisotropic (directional scattering from circumsolar, horizon, and ground components) diffuse atmospheric conditions can be evaluated, based on a model developed by Klucher (1979).

Ground reflectance is user-defined on a month-by-month basis. LCP thus allows for seasonal change in reflectance due to snow or other site-specific conditions.

The model can generate estimates of energy output in either solar time or local standard time. For the latter, the model requires the user to define the local longitude and the standard longitude for the local time zone.

LCP allows the user to enter vectors of monthly input parameters for a wide variety of performance inputs (as opposed to requiring fixed rates), allowing the user more flexibility.

The program was originally written in SIMSCRIPT but has been extended to operate on microprocessor equipment using MBASIC, trademark of Microsoft Corporation (Davisson et al., 1983).

The model can be summarized as a system-level model for flat-plate array design, performance trade-offs, and system operations over time, including effects of mismatch, shading, cell failure and replacement, dirt accumulation and cleaning, maintenance, and life-cycle costing.

C. PHOTOVOLTAIC F-CHART MODEL (PV F-CHART)

The PV F-CHART model was developed as a simplified model to provide long-term (average) performance estimates for fixed, tilted, flat-plate photovoltaic systems having utility feedback capability, battery storage, or neither of these options (Klein and Beckman, 1983; Siegel, et al., 1981; Clark, et al., 1983). Figure 4-3 illustrates the overall format of the model. In each of these system configurations, by assumption, power conditioning equipment maintains the array output at its maximum power point and supplies the proper voltages and current to the other equipment. The monthly-average hourly load on the system is supplied by the user. Power generated in excess of that needed to supply the load is either fed back to the utility, stored in a battery, or dissipated. Energy required by the load which is not supplied by the system must be obtained from an (unspecified) auxiliary source.

The array output is estimated as the product of the total array area, the monthly-average hourly solar radiation, and average array efficiency. Insolation on the flat-plate array is calculated for any tilt and azimuth orientation using a modified Liu and Jordan (1960) approach (updated with recent long-term average diffuse and total radiation measurements), which results in an insolation profile for each month. Each hourly value represents the expected long-term radiation for that time interval. The array efficiency includes the

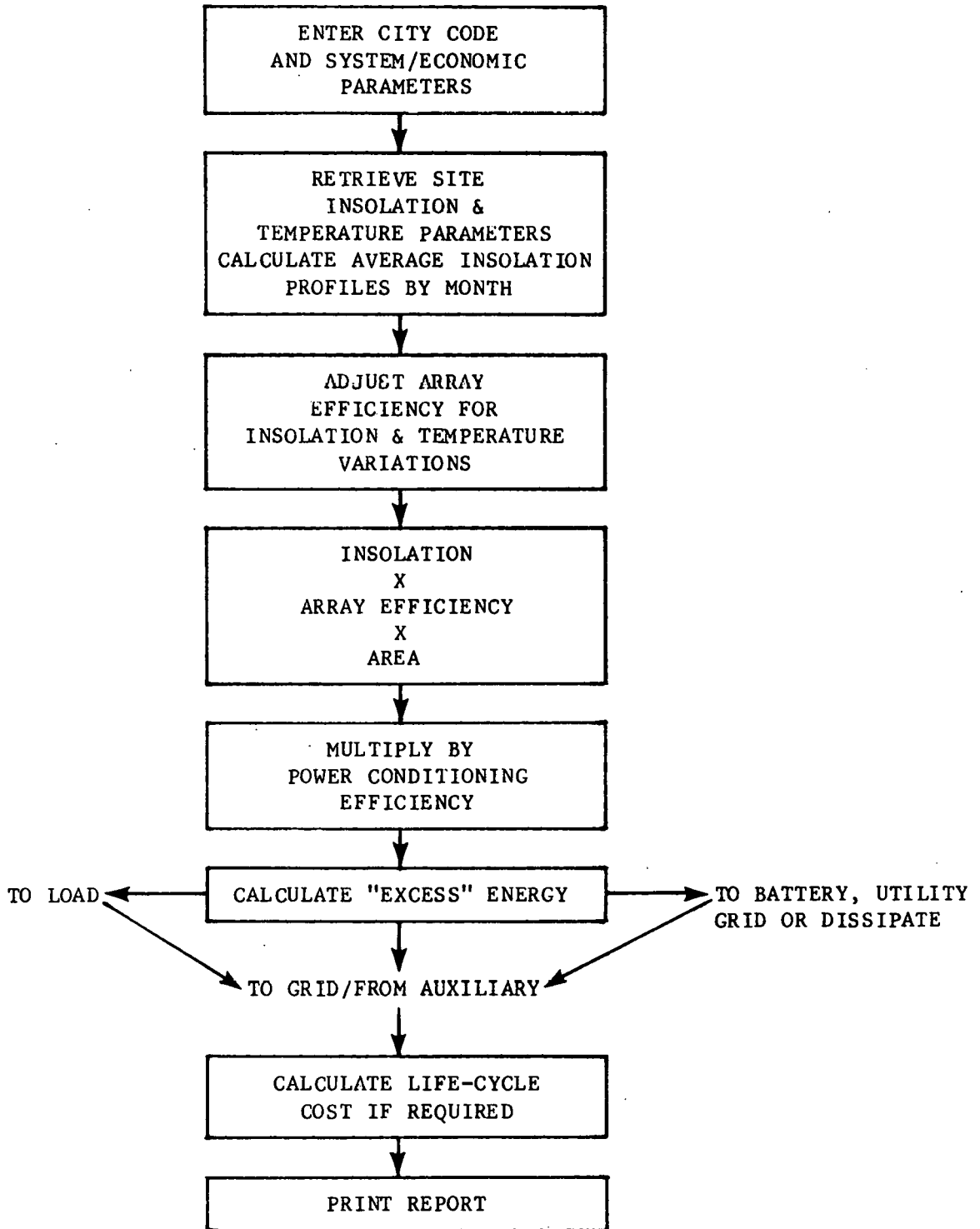

Figure 4-3. Photovoltaic F-CHART Model Structure

angular dependence of the array transmittance and absorptance of solar radiation. Because of the aggregated nature of the calculation, no discussion of Cell and Module Characteristics is presented.

Not all of the array output is necessarily used by the load. There may be times when the electrical energy produced by the array is greater than that needed to satisfy the electrical demand, i.e., the load. This excess energy may be fed back to the utility, stored in a battery, or dissipated, depending on the system under consideration. The long-term monthly excess energy for any hour is affected by the long-term distribution of the load, the solar radiation, and the ambient temperature. While this "time-of-day" calculation uses average values for excess energy, load, temperature, and solar radiation, no assumption is made regarding the relationship that can exist between temperature and load (e.g., air conditioning). The amount of excess energy is calculated using the concept of solar radiation utilizability. A critical radiation level is defined as the radiation level that results in an array output equal to the monthly-average load for the hour. Radiation above this critical level results in excess array output. Solar radiation utilizability is the fraction of the monthly-average hourly solar radiation above the critical level that is calculated in the program using the algorithm devised by Clark, et al., (1983). The utilizability statistic is used to estimate the monthly-average hourly energy in excess of the average hourly load. The fraction of monthly load supplied by the PV system can then be estimated.

1. Orientation and Geometric Characteristics

The model is designed to characterize fixed, flat-plate systems at any tilt or azimuth and uses standard geometric relationships for estimating monthly-average hourly insolation on the array, using monthly-average daily horizontal radiation data values (one for each hour in the averaged-day of each month). These data are held internally within the program for 244 locations and a city code entered by the user retrieves the climate parameters and calculates an average hourly insolation profile and the solar radiation utilizability for the orientation of interest for each month. The capability to model encapsulant refraction (i.e., Fresnel refraction) is not explicitly included. No tracking or concentration options are included at this time. The user can readily conduct sensitivity analyses on tilt and azimuth angles.

2. Array-Level Characteristics

The PV F-CHART approach assumes no mismatch, cell or module failures, series/parallel configurations, or shading. In fact, the model does not address reliability or detailed electrical calculations. The focus of the model is on providing first-order estimates of system performance, based on calculation of the aggregate system performance using long-term average insolation, temperature, and load profiles. This emphasis on simplicity is designed to reduce burdensome calculations and allow the user to conduct sensitivity analyses in real time. The algorithms are based on the work of Clark (1982) and Siegel (1981) who used the TRNSYS code to evaluate the algorithms (the TRNSYS/ASU version is reviewed later).

The model has been implemented for operation on a number of microcomputers and is self-contained, requiring approximately 15 inputs to characterize

performance and approximately 30 inputs to specify the economic/financial parameters for life-cycle cost analysis. The performance parameters are summarized in Table 4-1.

The array temperature is determined from the cell temperature under no-load at nominal operating cell temperature (NOCT) conditions (20 °C and 800 W/m²). The NOCT can also be calculated from the array transmittance-absorptance product (ta), and array overall heat transfer coefficient (U, if available). This relationship is given by:

$$\text{NOCT} = (800 \text{ W/m}^2) * (\text{ta}) / U + 20$$

The array reference efficiency is the product of the cell packing factor and the cell reference efficiency determined at a reference array temperature. The array reference temperature is a temperature at which the array efficiency is known. An array temperature coefficient is used to modify the overall efficiency calculation. This coefficient is the rate at which the array efficiency linearly decreases with temperature for maximum power-tracking operation. Like a number of the models reviewed here, the cell/array efficiency is taken as a linear function of cell temperature and is primarily a function of the cell material:

$$\text{EFF}_{\text{array}} = \text{EFF}_{\text{ref}} [1 - C(\text{T}_{\text{cell}} - \text{T}_{\text{ref}})] * \text{EFF}_{\text{pt}}$$

where:

- T_{cell} = cell temperature
- $\text{EFF}_{\text{array}}$ = array efficiency
- EFF_{ref} = array reference efficiency (cell packing factor x cell efficiency at reference temperature T_{ref})
- C = temperature-efficiency coefficient (constant)
- T_{ref} = cell reference temperature
- EFF_{pt} = power tracking equipment efficiency

Table 4-1. Photovoltaic F-CHART Array Model Inputs

City Call Number
 Output Formats
 Array Area
 Cell Temperature at NOCT Conditions
 Array Slope
 Array Azimuth (South=0)
 Array Reference Efficiency
 Array Temperature Coefficient * 1000
 Power Tracking Efficiency
 Power Conditioning Efficiency
 Percent Variation of Load
 Effective Battery Capacity
 Battery Efficiency

The model does not address topics such as shading by adjacent arrays.

3. Power Conditioning Unit Characteristics

The PCU is characterized with a single constant user input power conditioning efficiency. This factor is multiplied by the aggregate power to account for losses due to PCU operation.

Although the model is capable of maximum power tracking, it is characterized in terms of a single user input power tracking efficiency, which is applied uniformly within the model to account for control logic and the associated equipment.

4. Plant-Level Characteristics

Balance-of-system losses due to wiring, connectors, or other parasitics are not input explicitly although, because of the multiplicative nature of the model, the power conditioning or tracking efficiencies could be externally adjusted to incorporate these effects.

The load is input as average hourly values representing a typical day for each month and depending on the option selected, any excess energy may be fed back to the utility connection, stored in a battery, or dissipated. The long-term monthly excess energy for any hour is affected by the load, the ambient temperature, and the solar radiation for that hour. While this "time-of-day" calculation uses expected values for excess energy output, temperature, and solar radiation, no assumption is made regarding the relationship that can exist between temperature and load (e.g., air conditioning). The amount of excess energy is calculated using the concept of solar radiation utilizability. A critical radiation level is defined as the radiation level that results in an array output equal to the monthly-average load for the hour. Radiation above this critical level results in excess array output. Solar radiation utilizability is the fraction of the monthly-average hourly solar radiation above the critical level which is calculated in the program using the algorithm devised by Clark, et al., (1983). PV F-CHART allows the load distribution to be entered on a monthly-average hourly basis, thus incorporating considerable generality with regard to the types of loads that can be considered. If the actual hourly demand is not constant at the average value but varies from day to day, the assumption of constant load will cause an underestimation of the excess energy; and this is an overestimation of energy to load. In addition, variations within each hour will further exacerbate the overestimation of energy to load (Hart, 1982d,e). The model accounts for varying loads using an expected value formulation for solar radiation utilizability, which weights the excess load by a probability distribution of the load. This distribution is assumed to be a uniform distribution with mean equal to the monthly-average hourly load and a minimum to maximum range equal to the product of the mean and the value entered for %VARIATION OF LOAD. The implication here is that the distribution of values about the mean is completely random. No assumptions are made regarding possible relationships between temperature/season and load (e.g., air conditioning) and their effect on this distribution. That is, in months with large changes in load due to weather patterns, the actual distribution need not be uniform.

The performance increase in the PV system due to adding a battery is expressed in terms of the incremental fraction in monthly load supplied with storage versus no storage. An equation that yields the maximum incremental energy is presented, which is an empirically derived relationship and based on comparisons with TRNSYS/ASU simulations conducted by Clark (1982). It is noted that the comparisons are based on "...73 years of hourly simulations (of the TRNSYS/ASU model) using 15 different load profiles in Seattle, Madison, and Albuquerque climates. The procedure for estimating the load fraction of battery storage systems agrees with the simulation results with a standard deviation of less than 3% on an annual basis."

5. Operations and Maintenance Characteristics

PV F-CHART does not address the problems of cell failure, replacement, dirt accumulation, cleaning, or other types of O&M topics, and thus modeling of operations and maintenance for performance calculations is not done. However, the model does conduct a life-cycle cost analysis that reflects the impacts of operations and maintenance through user-specified cost factors. The user must estimate these costs for the system and input a total insurance and maintenance cost for the first year. This value is then escalated over the lifetime of the system with a user specified escalation rate.

6. Site-Specific Characteristics

The calculations are based on a formulation that requires long-term, monthly-average insolation and temperature values and the latitude of the site. A modified Liu-Jordan (1960) solar radiation model is used to generate the hourly insolation values. The input requirements to the solar radiation model are minimal, so all of the data for the 244 locations are contained within the program. The model divides the global horizontal insolation into its direct, diffuse, and diffuse-reflected components, using a model developed by Erbs, et al. (1982), and then orients each component for the array orientation selected and calculates the total. The diffuse radiation calculations assume an isotropic atmosphere throughout, and ground reflectivity is a user input constant that can be varied monthly. The result is a set of 12 average-day profiles of average hourly insolation for the user selected surface orientation. Because of the symmetric nature of the calculation, the corresponding hours from solar noon (such as 11 a.m. and 1 p.m., 10 a.m. and 2 p.m.) would have the same average radiation levels. All the geometric calculations are performed in solar time.

The model is straightforward and provides useful information as a first-order performance and economic calculation based on long-term averages for fixed, flat-plate PV systems.

The program is written in BASIC and will run on a variety of micro-computers.

D. PHOTOVOLTAIC PERFORMANCE MODEL (PVPM)

The PVPM model developed for the Electric Power Research Institute (EPRI) by Boeing Computer Services performs first-order approximations of a PV

system's instantaneous response to insolation (R. Taylor, personal communication, 1983). Figure 4-4 illustrates the structure of the model. PVPM does not model PV systems at the level of detail of SOLSYS, SOLCEL-II, LCP, or TRNSYS but is more akin to PV F-CHART in terms of its general purpose. Studies of annual PV system output sensitivity to system parameters can be accomplished, using PVPM as well as first-order estimates of average hourly PV system performance. Detailed sub-hourly analyses of PV systems that include transient effects are beyond the scope of this model and its purpose.

The model uses hourly-average insolation and temperature inputs for each month to determine the system's instantaneous energy output. Array output is the product of insolation at the array, array area, and efficiency (as a function of cell temperature) for flat-plate or concentrating arrays.

1. Module Characteristics

Individual cell characteristics are not explicitly modeled. The module is assumed to behave as an equivalent large cell. Effects of series versus parallel wiring, bypass diodes, or encapsulant refraction are not modeled. Module temperature is calculated, using a linear equation similar to a number of models examined in this review. The user inputs two coefficients and the reference cell temperature and efficiency. The form of this calculation is:

$$T_{\text{module}} = T_{\text{amb}} + m S$$

$$EFF_{\text{module}} = EFF_{\text{ref}} [1 - C(T_{\text{cell}} - T_{\text{ref}})]$$

where:

$$T_{\text{module}} = \text{cell temperature}$$

$$T_{\text{amb}} = \text{ambient temperature}$$

$$m = \text{insolation-temperature coefficient}$$

$$S = \text{incident insolation}$$

$$EFF_{\text{module}} = \text{operating module efficiency}$$

$$EFF_{\text{ref}} = \text{reference module efficiency}$$

$$C = \text{temperature-efficiency coefficient}$$

$$T_{\text{ref}} = \text{cell reference temperature}$$

Module temperature is the primary determinant of variation in module efficiency. PVPM does not consider the cell current-voltage characteristics, the effects of inter-cell electrical mismatch, or cell failures. Certain degradation effects are included and discussed under Array-Level Characteristics.

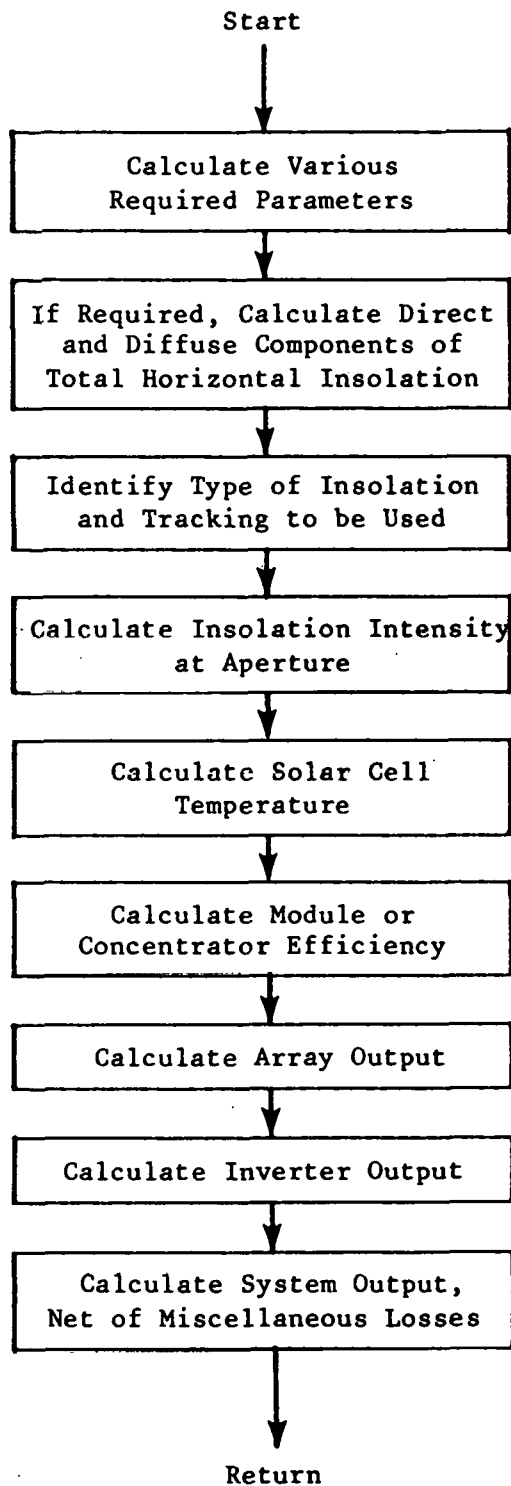

Figure 4-4. Photovoltaic Performance Model Structure
(Source: Taylor, 1983)

2. Orientation and Geometric Characteristics

PVPM includes several flat-plate and concentrating PV system configurations. The options are similar to those of most of the other models in this review. Flat-plate array systems can be fixed (at any tilt and azimuth angle); one-axis tracking on a horizontal E-W axis; one-axis tracking on a horizontal N-S axis; tracking about an axis parallel to the polar axis; or two-axis tracking. Concentrators may use any of these tracking methods.

The geometrical model, which calculates insolation at the array, uses methods similar to those of Liu and Jordan (1960). One of three types of insolation data can be input: total horizontal, plane-of-array, or direct normal insolation. An algorithm developed by the Aerospace Corporation (Randall and Biddle, 1981) is used to translate total horizontal insolation into total insolation received by any collector surface, whether tracking or fixed, flat-plate or concentrating.

3. Array-Level Characteristics

The standard EPRI model does not address inter-array shading separately but rather as part of a miscellaneous loss percentage. Shading is simply a user input as a percentage reduction of the total energy output. There have been extensions made to this by Black and Veatch for EPRI.

Neither degradation nor failures are explicitly modeled in PVPM. Furthermore, intra-array electrical mismatch and series-parallel wiring design are not included. These losses could, however, be included in the miscellaneous constant loss percentage if the user had reasonable data with which to estimate a loss factor.

Array output power is the product of the module efficiency (determined above), the insolation at the module surface, the number of modules, and the area per module. The concentration efficiency is also included as a multiplier for the concentrator option.

4. Power Conditioning Unit Characteristics

The inverter curve is modeled by the formula:

$$C_1 - C_2 / (\text{input power})$$

where C_1 and C_2 are module-specific input parameters. The input power is the dc output from the arrays. The output of the inverter is limited to its maximum rating.

PVPM does not consider maximum power tracking or voltage regulation. The PCU affects the system output only through its efficiency.

5. Plant-Level Characteristics

Balance-of-system losses are aggregated into the miscellaneous loss percentage (see above). Losses for module degradation, dirt accumulation,

mismatch, wiring losses, parasitic power losses, etc., are considered by PVPM in the aggregate. The percentage is applied as a constant over time.

Utility and load interconnections with the PV system are not modeled because PVPM focuses on system performance only. Battery storage is not addressed.

6. Operations and Maintenance

PVPM treats array degradation and failure and operations and maintenance topics (e.g., module replacement and cleaning) as miscellaneous array-level constant losses.

7. Site-Specific Characteristics

The user inputs data for the type of insolation and temperature to be used (e.g., TMY data). (See Orientation and Geometric Characteristics concerning acceptable insolation data types and the diffuse radiation separation method). If diffuse radiation is included (non-concentrating arrays), then an isotropic atmosphere is assumed. The ground reflectivity of diffuse radiation is set at 0.50. Simulations can be done in local standard time, and local longitude is an input for this case.

PVPM is in the form of a callable FORTRAN subroutine with a main program and smaller routines internal to it. The program structure was chosen to allow users to locate and modify pertinent parts of the code for alteration or enhancements to the model.

The model can be summarized as a first-order performance calculation based on the product of array area, subsystem efficiencies, temperature-dependent array efficiency, and insolation.

E. PHOTOVOLTAIC TRANSIENT ANALYSIS PROGRAM (PV-TAP)

The Photovoltaic Transient Analysis Program (PV-TAP) is a nonlinear circuit analysis program designed and utilized for network analysis of electrical and thermal transients in PV array systems (Lamberski, et al., 1978, 1979; Anderson, et al., 1980; Lamberski and Collaros, 1980; Lamberski, et al., 1981a, 1981b. The BDM Corp., 1980). The PV cell model accepts insolation and ambient temperature inputs through nodal connections and outputs voltage, current, and power dissipated through nodal connections. It may operate in an interactive mode with the heat transfer modules, which represent the thermal properties of the cell and its environment. This interaction is accomplished by connecting the cell temperature and power nodes to heat transfer temperature and power nodes. Many of the internal elements may be specified with statistical distributions on their parameters. Figure 4-5 illustrates an example of how PV-TAP interprets a PV electrical network. In this example, a 40-kW array is modeled. Each PV module is composed of 40 series-connected cells; ten modules connected in parallel form a panel; 20 panels in series form a subarray; and 10 subarrays are paralleled to produce the array. The modeling represents the case in which one panel is shadowed. Nine subarrays may be modeled with a

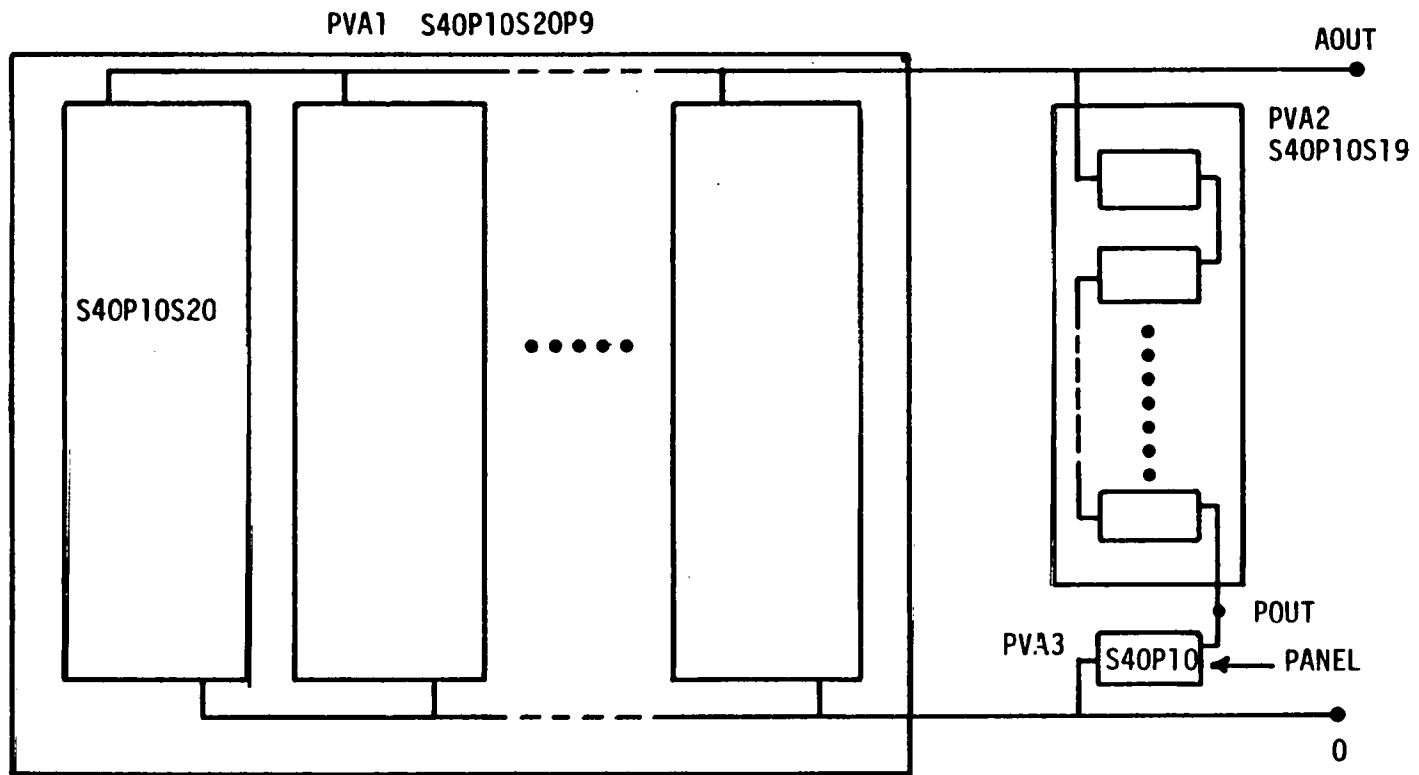

Figure 4-5. Typical Photovoltaic Transient Analysis Program Structure: Array With One Panel Identified Separately

single PV aggregate element (PVA1), which is built from single cell characteristic; 19 panels in the remaining subarray are modeled with another PV aggregate element (PVA2); the shadowed panel is modeled with a third element (PVA3). There are only three electrical nodes. AOUT and POUT represent the array and panel output nodes, respectively, and 0 is the reference node. Figure 4-6 is an example of a thermal representation of a PV cell. The designations at the top of the figure represents the division among thermal characteristics as modeled, using electrical networks. The program has time and frequency domain, Monte Carlo, and optimization solution capabilities. While the code could be used to address design topics for large systems, the descriptive nature of the model requires a large body of descriptive inputs. Thus, as the size of the system increases, the size of the input data set becomes correspondingly large. Depending on the nature of the cases to be run, the program allows the user to redefine or use a set of default inputs, thus reducing the effort required. Nonetheless, for systems with manageable inputs, the program can be used for modeling topics such as burnout analysis, illumination and load transients (e.g., lightning), fixed and propagating shadows, cell parameter optimization, collector and thermal system design trade-offs, power conditioning design analysis, and aggregation pattern trade-offs.

The PV-TAP model is very detailed modeling of instantaneous power. The program is an extension of the NET-2 (Release 9.1) Code developed by BDM Corporation to examine detailed electrical networks and their behavior under transient conditions. The approach views the cell as an element in a circuit (Malmberg, 1972). The user may interpret this cell as a particular level of aggregation. For example, if the user wished to use a module as the lowest level of detail in the network, the operating characteristics of the module would be input at the "cell" level. In this manner, the power source is a generic entity, which is aggregated like any circuit element to achieve the overall system response. There are a number of simplifications that the user may employ to reduce the calculations.

The electrical and PV elements include resistors, capacitors, batteries, collectors, thermal modules, and others. The elements can be expressed as either constants or variables in the form of tables or functions. Each device has a number associated with it from which an equivalent circuit and a set of controlling equations can be entered in the network calculation. Subnetworks can also be defined to represent subsystems.

There are three types of calculations available. The first is a state solution, which is a network response to prescribed inputs for either a steady-state or transient condition. The second is a Monte Carlo solution. PV-TAP can synthesize a large number of networks, each composed of network parameters with the different values, analyzing the performance of each of these networks, and then summarizing the results as a set of performance statistics. The third approach provides an optimization solution based on minimization of specific network parameters within allowable parameter space. It is recognized that this may yield only a local optimum.

1. Cell Characteristics

The PV cell model represents the basic unit for which the user has I-V curves, either a single PV cell or a module composed of many series/parallel

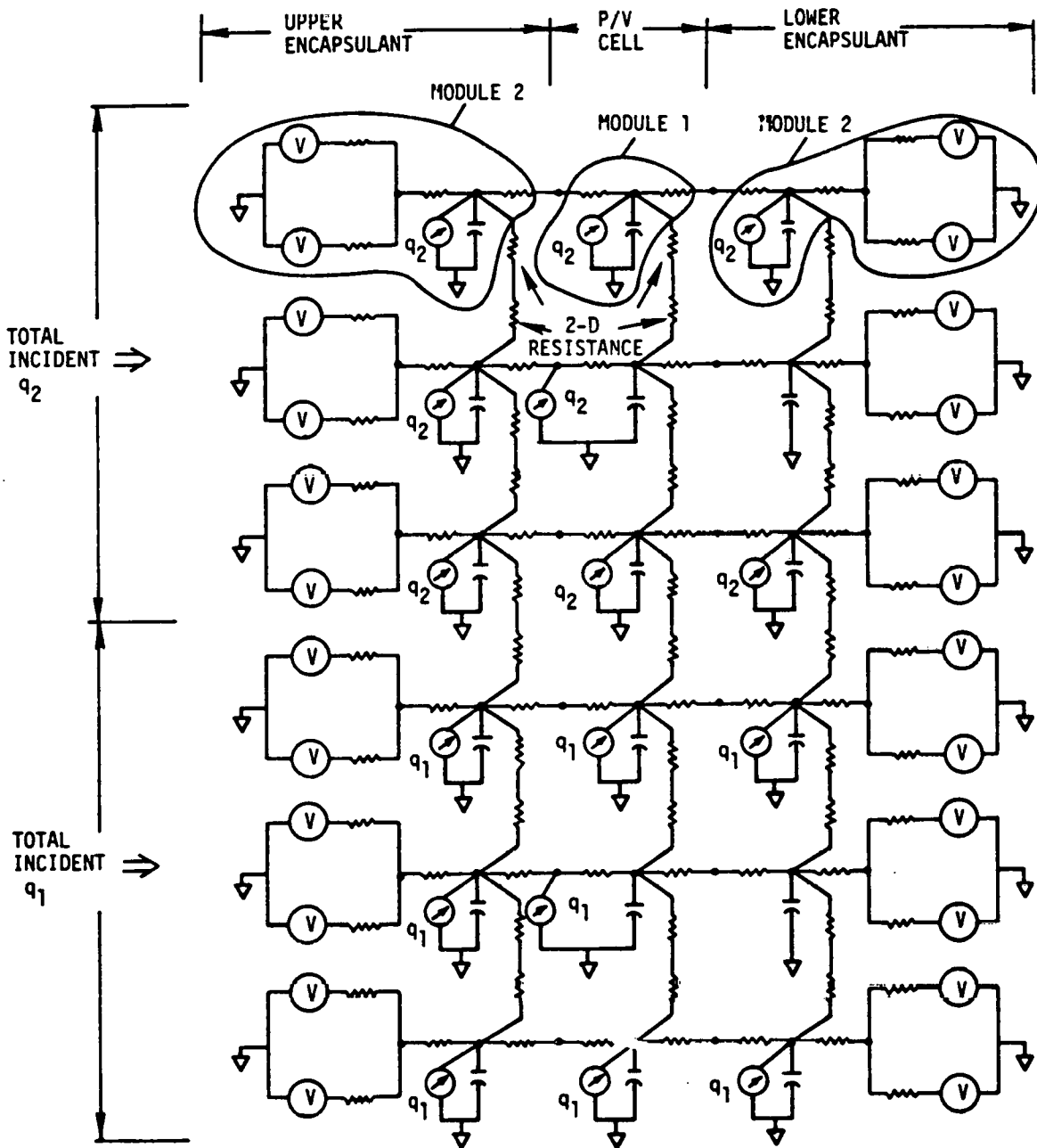

Figure 4-6. Example of Flat-Plate PV Cell Thermal Model Electrical Analog

PV cells. The PV cell model is based on an Ebers-Moll formulation, which assumes that the distributed cell characteristics can be modeled with lumped, single exponential elements. Care must be taken in using this type of approach with high levels of concentration as found by Evans, et al. (1978). The model parameters are determined from PV cell measurements or from manufacturer supplied specifications. The detailed models are provided in the PV-TAP documentation; however, a list of inputs are reproduced in Table 4-2 to provide an indicator of the level of detail. Default parameters are stored in PV-TAP; thus, for most analyses only a subset of inputs need to be provided by the user. The cell I-V curves can be aggregated directly, using the conventional rules (for cells in series voltages add and for cells in parallel currents add). These procedures preserve the current limiting behavior of lower quality cells and thus capture the effects of mismatch. However, using the statistical distribution of modules for the parameters (an option), the resulting mismatch would be a statistical quantity rather than the actual response for specific elements.

Cell temperature can be input descriptively as a constant or variable over time or modeled as the solution to a detailed heat transfer model. The heat transfer model models the thermal aspects of the network, using an elec-

Table 4-2. Photovoltaic Transient Analysis Program
Cell Model Inputs

Symbol	Name	Units
A	Breakdown Constant	v ⁻¹
B	Breakdown Constant	NONE
C	Transition Capacitance V = 0	pF
CS	Nonlinear Effects Coefficient	sun ⁻¹
CST	Nonlinear Effects Coefficient	(sun ⁰ K) ⁻¹
CT	Nonlinear Effects Coefficient	°K ⁻¹
CTT	Nonlinear Effects Coefficient	°K ⁻²
G	Inverse of Shunt Resistance	mmho
IS	Saturation Current Constant	mA/°K ^P
IP	Photocurrent Generation Constant	mA/sun
M	Emission Constant	None
N	Junction Grading Constant	None
P	Power (Exponent) of Temperature	None
RS	Series Resistance	k
T	Minority Carrier Lifetime	ns
VB	Breakdown Voltage	V
VZ	Contact Potential	V
W	Diffusion Capacitance Constant	ns ⁻¹
SR	Reference Insolation	suns
TR	Reference Temperature	°K
KSC	Solar Input Power Constant	mW/sun
QK	Charge/Boltzmann Constant	°K/V
ALPHA	Temperature Coefficient	°K
ETA	Breakdown Current Scaling Constant	mA

trical network equivalent (ENE) of the circuits. This electrical/thermal analogy rests on the similarity between the flow of heat within a rigid body and the flow of charge in a noninductive electric circuit. These similarities can be summarized as:

- (1) Conservation of heat corresponds to conservation of charge.
- (2) Electric potential (voltage) corresponds to temperature.
- (3) Ohm's law corresponds to Fourier's law.
- (4) Electric capacity corresponds to thermal capacity.

The inputs required include:

- (1) Area over which heat transfer is taking place.
- (2) Conductivity of material.
- (3) Material thickness or distance.
- (4) Film coefficients
 - (a) Convection to external flow.
 - (b) Convection to a fluid for cooling.
 - (c) Free convection.
- (5) Fraction of total emission from each of the radiating surfaces.

The heat transfer calculations specify the temperature of a PV cell or any other point of interest within an array as a function of time through the transient or steady-state conditions. There are three elements to the heat transfer equations. The first represents an internal thermal node that can conduct heat from the center capacitance to the boundary of the nodes. It can be used for the cell or an internal node within the encapsulant or substrate. The second represents a thermal node that has one internal boundary and one external boundary from which thermal energy is rejected via convection and radiation to ambient conditions. This can be used to represent the encapsulant surface. The third element models the thermal behavior of any material with two external surfaces such as a Fresnel lens or glass cover. The three elements can be connected together to produce a thermal model for the PV array (see Figure 4-6). For additional details the reader is referred to the PV-TAP documentation.

Cell failures or degradation due to aging are not explicitly modeled. However, they could be simulated over time by varying the cell input parameters descriptively. Any attempt to model the occurrence of failures must be of an "add-on" nature. The code by itself has no inherent reliability or failure analysis capabilities.

2. Module Characteristics

The series/parallel aggregation of cells to the module level can be described deterministically or stochastically. The deterministic formulation keeps track of the individual and aggregated cell I-V curves by element number. The statistical formulation uses distributions on the parameters to produce a statistical representation of the aggregate module. Depending on which of the above approaches is used, the effects of mismatch are either deterministic or stochastic. The effects of adding bypass diodes (tunnel, Zener, junction) at various places within the network can also be modeled since they are straightforward electrical elements. Again, these elements are modeled to simulate the network response at each level of aggregation.

Module failure and degradation effects are not addressed, but they could be simulated by descriptively varying input values over time.

Refraction of the solar beam as it passes through the encapsulant material is not addressed for two reasons. In the first case, the available insolation on the surface orientation is modeled as a gain multiplier which weights solar radiation by the cosine of the incidence angle of the sun on the surface. This yields effective energy available to the network. Thus, there is a cosine relationship between the incoming radiation and the available radiation to the collector surface. In the second case, after the gain multiplier is defined, the path of the solar beam becomes irrelevant because the available insolation is then modeled as a voltage source to ground device within the circuit network.

3. Orientation and Geometric Characteristics

The PV-TAP approach to modeling the solar radiation for the surface orientation of interest is unique in the context of the models examined here. The various collector systems are treated as electrical amplifiers for the PV system. The available component of insolation available for conversion models the direct normal solar radiation. The direct component model is contained within PV-TAP; however, the user interested in modeling flat-plate systems with the direct and diffuse radiation components must provide the diffuse element. The applications for which the code is used typically ignore the type of collector system and models insolation as a voltage source. PV-TAP was developed for detailed design tradeoffs, not site-specific studies. The model emphasizes parametric analyses for time intervals of a day or less (to the submicrosecond level). The focus of PV-TAP is on relative performance, using varying network design assumptions rather than modeling site-specific solar radiation characteristics. The options available for various collectors are:

- (1) Fixed south-facing: $S_o = SA \cos(p) \cos(q)$ (user provides diffuse)
- (2) North-south one-axis tracking: $S_o = SA \cos(q)$
- (3) East-west one-axis tracking: $S_o = SA \cos(p)$
- (4) Full two-axis tracking (flat-plate or Fresnel lens): $S_o = SA$

where S_0 is the component available for conversion; S is direct insolation at solar noon; A is effective gain including concentration ratio and cell packing fraction; and p and q are solar tracking angles (altitude and azimuth). PV-TAP can also model concentrating collectors. Those included are flat-plate Fresnel lens (two-axis tracking); fixed east-west parabolic trough, north-south one-axis tracking parabolic trough; and a compound parabolic trough that operates in an east-west orientation.

There is no capability for manually specifying variable flat-plate tilt angles for the fixed case (for simulating seasonal or monthly adjustments), or controlling tracking periods to minimize shadow losses. In general, such system level studies are beyond the scope of PV-TAP's design purpose.

4. Array-Level Characteristics

The series/parallel specification of the array-level represents another level of aggregation that PV-TAP can model. Most features of the PV cell are maintained throughout the analysis; however, some elements cannot be carried along under certain schemes. At each level of aggregation the result is approximated with a new single "cell" element that represents an array. Again, the network can be specified deterministically or stochastically and mismatch is modeled accordingly.

Shading per se is not modeled in PV-TAP. The user interested in the position of a shadow must provide the geometric path of the shadow over the system as an external input. PV-TAP models the time lags in electrical and thermal response for this externally provided shadow as it moves over the array. The user specifies the cells that are shadowed as a function of time. The input then undergoes simple time delays, representing the travel time of the shadow across segments of the array. The user must include the effects of the shadow in the insolation input to the shadow model. As one might expect, the input requirements to this approach are substantial. The user must have access to climatological data for the design area, including attenuation factors, intervals between clouds, and duration of cloud coverage. In general, these data are not available although some studies have been conducted (Randall et al., 1980). PV-TAP does not address time varying shading from adjacent arrays. Power losses due to shading from adjacent arrays must be calculated externally and used descriptively.

5. Power Conditioning Unit Characteristics

PV-TAP can model a number of power conditioning options. Maximum power tracking is modeled in detail, using the power tracking resistance modeled as a user input function of changes in the Thevenin source impedance. The power tracking resistance acts as a low pass filter with a time constant. This time constant is the only input required to model maximum power tracking and can be obtained from measurements of inverter response or manufacturer's specification. The use of fixed voltage or multiple inverters is not addressed in the documentation, but it may be possible to simulate these effects descriptively. There is a regulator model that uses a battery model to block transient pulses or charge/discharge the battery.

6. Plant-Level Characteristics

The balance-of-system losses may be modeled as a single resistance or with more complex elements by PV-TAP. The user can provide externally derived constants (resistances) for wiring, connection, and other parasitic losses as they correspond to each cell and the wiring pattern for the overall circuit. These losses are applied to the appropriate elements as the aggregation is performed.

The type of connection to the load is characterized by the load behavior, which is an input provided by the user.

There are two battery models in PV-TAP. The first models the power storage process, using the open-circuit voltage at full charge, the battery capacity, and the discharge curve. The second models the transient response of the battery in terms of impedance for transient or ac signals of a specified frequency. Energy storage is not modeled when the transient model is used.

7. Operations and Maintenance

The focus of PV-TAP is on electrical transient analysis. The capabilities to model O&M topics such as cleaning, reliability, module replacements, and costs are not present. Using the PV-TAP network, repair of electrical components (and the resulting mismatch due to different quality modules) could possibly be modeled separately and overlaid on the existing structure.

8. Site-Specific Characteristics

As mentioned earlier, PV-TAP uses only the direct component of solar radiation as an input. Therefore, if site-specific insolation data are to be used, a diffuse component must be added with external elements for flat-plate and low concentration systems. The PV-TAP code is not recommended for site-specific performance calculations and other codes should be used for these analyses (Lambariski, personal communication with J. H. Smith, 1983). Likewise, the model does not address atmospheric differences or ground reflectivity.

Depending on input data availability, the time scale can be simulated at the sub-microsecond level for studying high speed transients such as lightning effects or other transient pulses in the system. The model does not check for sunrise or sunset or make translations between local and solar time since these capabilities are not generally required for the types of applications for which PV-TAP is used.

The program is written in FORTRAN and runs on specific CDC and IBM equipment because some of the routines are written in assembly language.

The model can be summarized as a detailed, descriptive model of PV electrical networks for the parametric analysis of transient responses in electrical networks and electrical design trade-offs.

F. SOLAR CELL MODEL, VERSION II (SOLCEL-II)

SOLCEL-II, the upgraded version of SOLCEL (Linn, 1977), developed by Sandia National Laboratories, is a detailed hour-by-hour, cell-level model of PV systems (Hoover, 1980). Complete systems may be modeled, including energy storage, power conditioning, and electrical back-up systems. Figure 4-7 illustrates the key elements of the model. A large portion of the model is concerned with thermal analysis of a PV cell, including various active and passive cooling methods. SOLCEL-II has the capability to optimize a set of system parameters in terms of cost relative to a set of user specified design parameters.

1. Cell Characteristics

Cell temperature is calculated using a detailed thermal analysis. The subroutines used in the thermal model are similar to those used in SOLSYS described later. The model can simulate flat-plate, single-axis concentrators, and two-axis concentrators. Cooling options are 1) for flat-plate: front surface cooling using natural or forced air, front and back surface cooling using natural or forced air with an option for a finned back surface, water cooling tubes mounted on the back of the array with 0, 1, or 2 glazings; 2) for single-axis concentrators: same cooling options as above except no glazing option is included, 3) for two-axis concentrators: passively or actively cooled arrays, using either air or water. Fins may be used in all options to increase the cooling area. The thermal analysis for the two-axis concentrator is more detailed than for the other two options.

SOLCEL-II does not address the issue of system performance degradation. Thus, cell failure and cell electrical mismatch are not included.

A cell I-V curve is not modeled per se; however, certain voltage and current data are input to the model. Data for open circuit voltage and short circuit current for various combinations of high and low temperatures and insolation are inputs. Interpolations are then made to determine the maximum power operating point at any given input weather conditions.

None of the module characteristics considered in this study are modeled in SOLCEL-II; therefore, this category is not included. Module characteristics are assumed to be identical to the cell characteristics.

2. Orientation and Geometric Characteristics

A variety of orientations for each collector type are included. For flat-plate they are: horizontal, south facing and tilted, horizontal east-west or north-south tracking collectors, and a tilted collector tracking on a vertical axis. For concentrators: two-axis tracking, tilted one-axis collector tracking on a vertical axis, one-axis south facing tracking on an east-west axis, and one-axis concentrator facing south at an angle without tracking. The geometric model used for these options is similar to those used in other models in this study. The effect of Fresnel refraction through the encapsulant is not modeled.

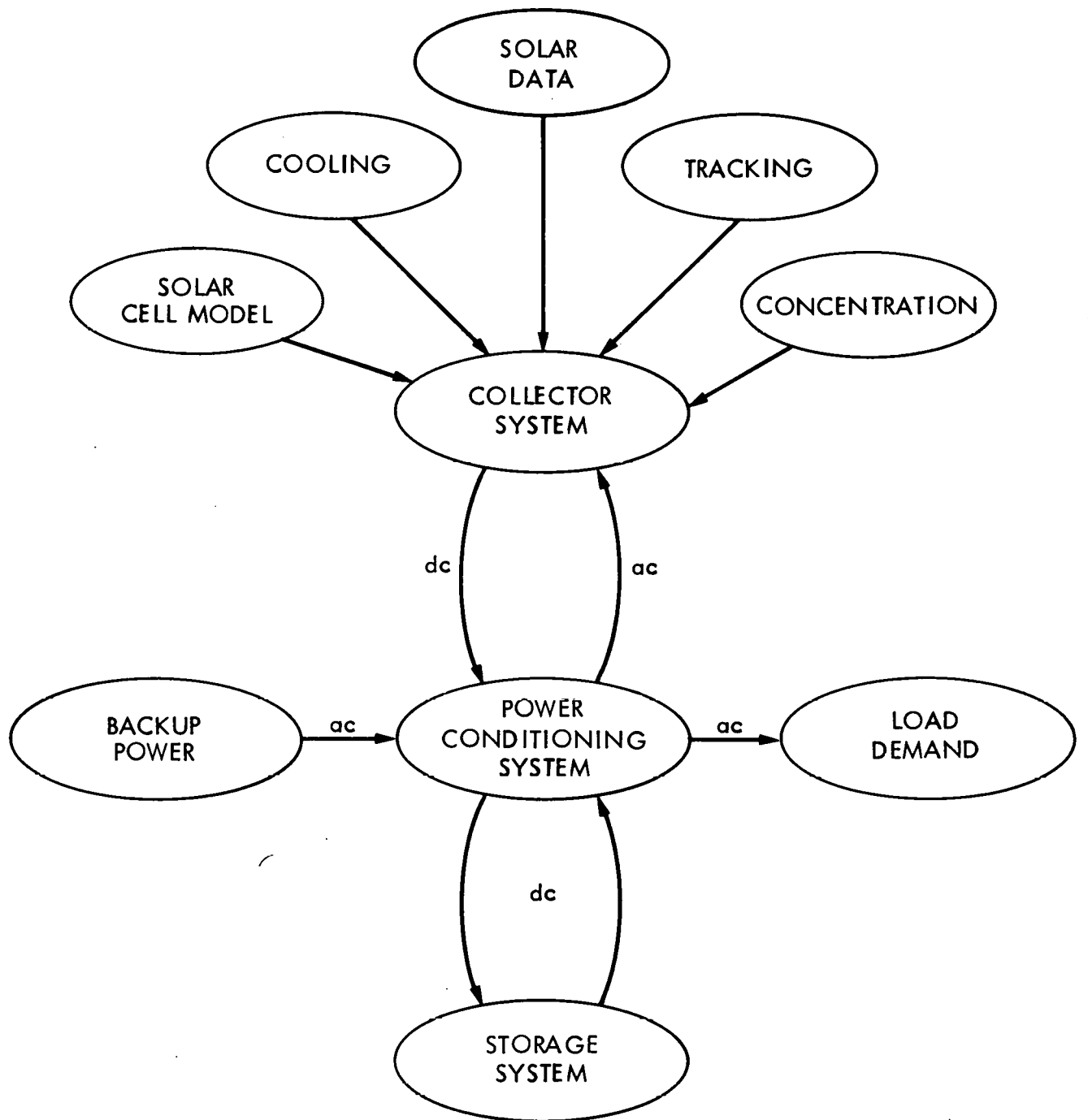

Figure 4-7. Solar Cell Model; Version II, Model Configuration
 (Source: Hoover, 1980a)

Array-level characteristics are assumed identical to module- and cell-level characteristics, so that category is not included. Array electrical mismatch, and series-parallel circuit design are not addressed. Other routines, external to SOLCEL-II, such as those found in SOLSYS for fixed, two-axis tracking, and one-axis north-south and east-west trackers, have been developed to handle shadowing.

3. Power Conditioning Unit Characteristics

The PCU can be modeled as a single dc/ac inverter with a load-dependent efficiency curve; two dc/ac inverters operating in parallel, each having the same efficiency curve; or a black box that converts dc to ac at a constant efficiency. PCU efficiency is a polynomial function of the fractional load. Fractional load is determined either from the dc input or by the required ac output using a separate formula for each case. The determination of which formulation to use depends on the user's choice of power distribution method chosen to meet the load demand (see plant-level characteristics). The efficiency curve is not user input but the size of the inverters and the peak efficiency are. A predetermined shape for the PCU efficiency as a function of load is included in the model. To change the efficiency formula, one would need to make changes to the code.

Maximum power tracking is based on the cell I-V characteristics, which are inputs. The maximum power point is interpolated from the I-V curve, insolation, and temperature data. The output is then modified by a maximum power tracker efficiency, which is modeled using a quadratic equation of fractional load.

Two options for voltage regulation are included as alternatives to maximum power tracking. The output voltage can be fixed to a certain level, or the output voltage can "float" to match battery voltage.

The PCU is assumed to overload if the rated size of the system is exceeded by more than 10% in any hour, and the resulting power output is set to zero.

4. Plant-Level Characteristics

Balance-of-system losses due to cooling or tracking power requirements are based on system PV power output. For those options that include active cooling, the pressure drop in the coolant piping is calculated, and the pumping requirements are determined. The electricity used by the pumps is considered a parasitic loss. For tracking collectors, power requirements for the tracker are calculated, based on collector size and type of tracking.

The user can choose one of three methods of power distribution and utility interconnection. In the normal distribution case, PV power is preferentially used to supply the load with battery backup and utility power is available if needed. Excess power is stored until no further storage capacity is available. A diesel generator can be selected as the final backup instead of the utility. If one selects a utility ownership option, all PV power is used to supply load.

Hybrid lead-acid batteries are modeled with charge-discharge characteristics approximated by piecewise linear and exponential functions. The rate of charge and discharge per hour are limited to one-fourth of the battery rating. Long-term effects of self-discharge are not addressed. The depth of discharge for a given hour is limited to one-tenth of the battery capacity. The effects of degradation and operations and maintenance are not addressed in the performance calculations of the model.

SOLCEL-II is designed to optimize system variables with respect to levelized busbar energy cost or total life-cycle cost. Operations and maintenance costs are addressed in the life-cycle cost models. The variables that can be optimized are: collector aperture area, outlet temperature of the cooling system, collector tilt angle, dc/ac inverter rating, battery capacity, voltage regulator set point, number of cells in series, and number of battery cells in series. The program uses a simplex optimization method to minimize cost. If reduced run time is needed, the program can use data for every Nth day, reducing run time by a factor of N. The model can also perform a sensitivity analysis on the parameters listed above by stepping through a range of values defined by the user.

5. Site-Specific Characteristics

Four types of hourly site-specific data are required for SOLCEL-II: total horizontal insolation, direct normal insolation, ambient or dry-bulb temperature, and wind speed. The diffuse radiation component is calculated from the direct and total insolation. Ground reflectivity is assumed to be 0.5 in the code. The atmosphere is assumed to be isotropic for the diffuse radiation calculation. The simulation operates on solar time and does not have the capability to operate on local time.

The program was written in FORTRAN for CDC mainframe equipment.

The model could be summarized as a detailed thermal and electrical model of a solar cell extended to the system level by multiplication of insolation, efficiencies, and area.

G. SOLAR RELIABILITY MODEL (SOLREL)

The SOLREL model, developed at Battelle Columbus Laboratories, is a reliability analysis methodology using the GASP IV Simulation package that examines and computes maintenance and operating costs for PV components and systems (see Figure 4-8a, b). It differs from the other models in this study in that it is not a PV performance model. The E&R cell failure analysis model is used to predict array degradation due to cell failure and array electrical design, while Battelle's SOLTRM model (a derivative of the TRNSYS model) supplies the non-degraded annual system energy output. No calculations of solar position, insolation at the array, voltage regulation, cell temperature, or any other performance element are modeled. The model focuses entirely on availability and reliability topics, allowing the user to experiment with maintenance and repair strategies for a PV system and see the effect on availability and costs. These costs can then be input to a life-cycle costing model.

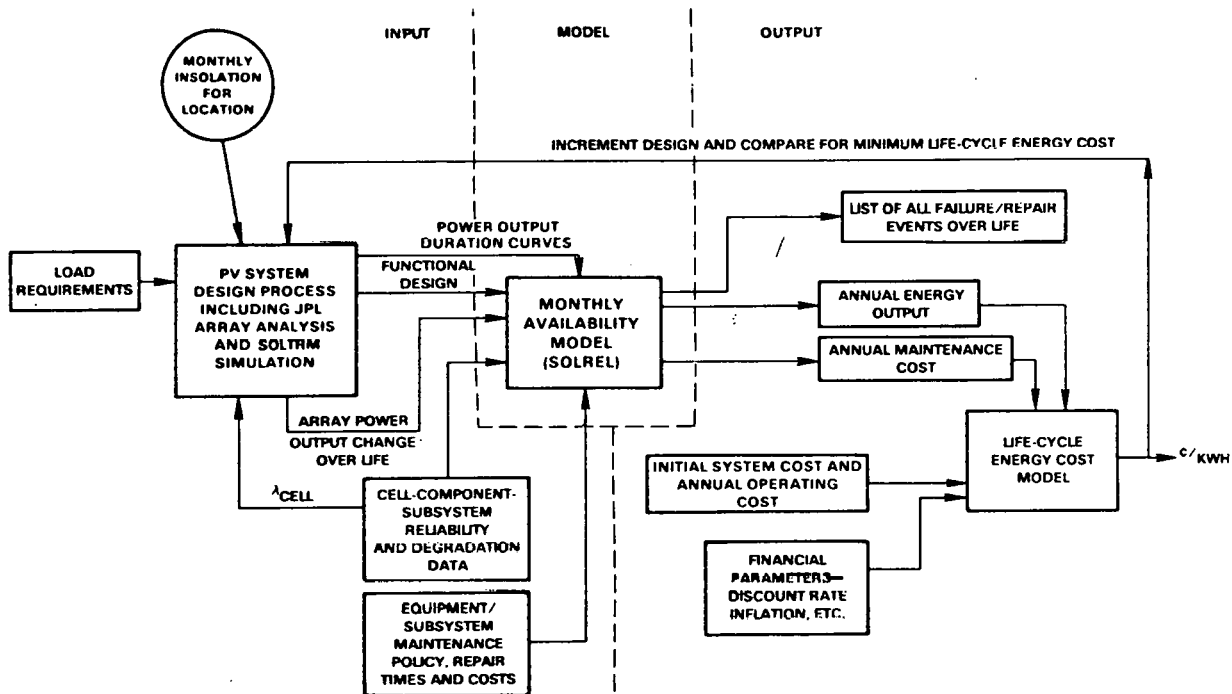

Figure 4-8a. Overview of Interactions of Availability Methodology with the System Design Process (Source: Stember, et al., 1983). The dashed line distinguishes the inputs and outputs from the model

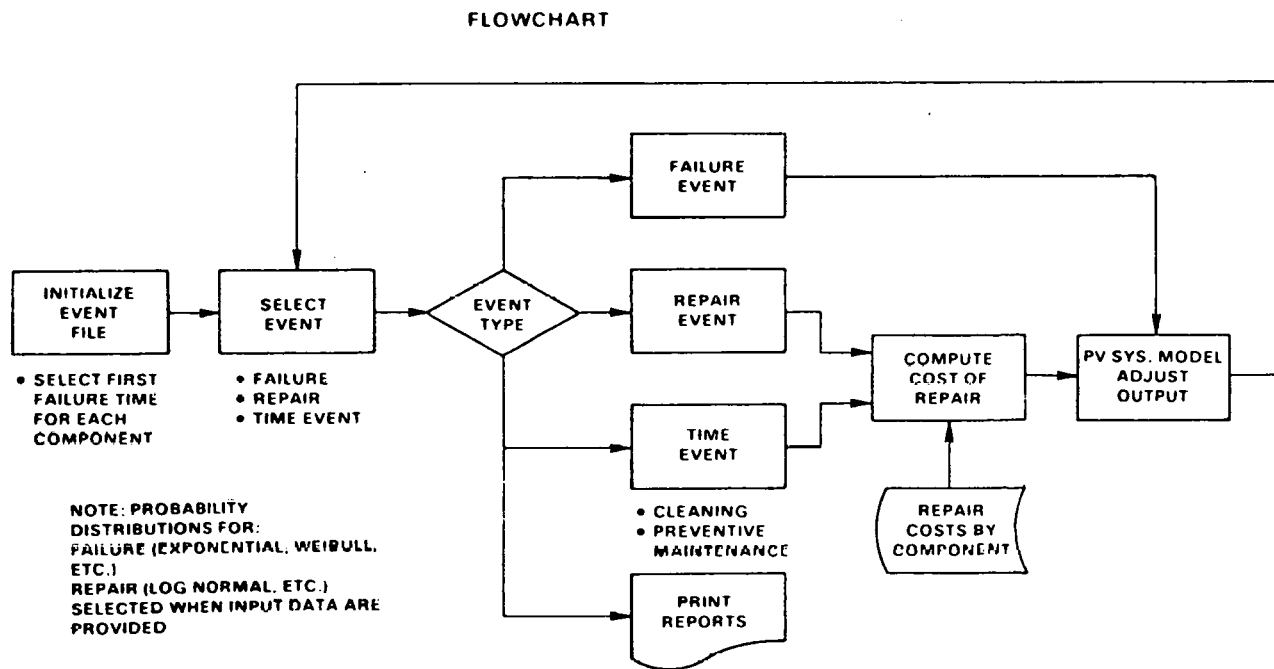

Figure 4-8b. Flowchart for Simulation Program - SOLREL (Source: Stember, et al., 1983)

SOLREL accepts data for system energy output in the form of output duration curves. These are monthly curves for the non-degraded system, which define the number of hours the system is at a normalized fraction of rated system output. The curves are modified by the program to account for system degradation. Data for energy degradation due to cell failure is input to the program. Such data can be obtained from other models or empirical data. The model gathers user-specified inputs for energy output, degradation due to failure, functional design of the system, and failure and repair rates, and then outputs an annual energy output stream, maintenance cost stream, and a list of all failure and repair events for the life of the system. A plotting routine for CALCOMP plotters and DISSPLA software from Integrated Software Systems Corporation produces plots of discounted and annual costs and energy outputs. The routine can be bypassed by the user if desired (e.g., if some minor changes to the code are made).

Because SOLREL can operate with performance inputs from a variety of models, it represents a different category of PV model. Rather than being an alternative to PV system performance models, SOLREL would be used in addition to some of them, using their performance results as inputs to the reliability analysis. Because of these differences, the topics covered in the descriptions of the other models do not apply for the most part. However, examination of SOLREL is consistent with the other models to the extent these limitations allow.

1. Cell Characteristics

A stream of annual array output energy degradation percentages are input by the user to the model. This degradation stream can be calculated in terms of the rate of cell failure per year, using direct empirical data on the E&R model. Also, input by the user are degradation fractions for permanent degradation because of scratching or yellowing of the cell encapsulant and dirt accumulation. These fractions are input for 3-year intervals.

SOLREL does not address module- or array-level characteristics for degradation, such as series/parallel wiring design and bypass diode placement or electrical mismatch between modules or arrays (as treated in the E&R model). The output energy stream (energy output duration curves in SOLREL's terminology) input by the user is degraded on a monthly basis only. Actual subsystem failures and repairs are investigated in detail as shown below. Because reliability of system components is the primary concern of SOLREL, Operations and Maintenance Characteristics is the only topic examined in detail in this review.

2. Operations and Maintenance Characteristics

SOLREL models the failure, repair, and maintenance of PV system components based on user inputs for mean time between failure (MTBF), mean time to repair (MTTR), and a preventative maintenance schedule. The user defines the components that make up the system (e.g., arrays, tracking drive, inverter, concentrating lens). Each component has an associated MTBF, MTTR, and preventative maintenance schedule as well as repair and maintenance, fixed and variable costs, and manpower requirements. Postulated failures due to

weather conditions such as high winds may also be included as an input. Probability distribution parameters other than MTBF or MTTR may be used for special probability distributions (e.g., log-normal, Weibull, exponential, etc.). Random failure events, and repair and maintenance times are generated by the model according to the distribution chosen.

The model performs a simulation over the system lifetime, recording all failures, repairs, and maintenance events as well as related costs. A table of all events, including an annual summary for each year, is printed out together with a table of annual kWh output and maintenance costs, expressed in both current and present value.

The energy output submodel modifies the output duration curves to reflect system failures or downtime due to maintenance. The model can distinguish between failures in series or parallel subsystems and reduces the output level accordingly. An availability analysis is also performed with respect to the total number of daylight hours. The output of this analysis is a table that shows the percentage of the time the system was performing at given levels of output for each year as well as averaged over the life of the system. A component failure table is also output showing the number of failures for each component for each year and the total. These failures impact the system performance by eliminating the relevant fraction of energy output.

Figure 4-8a shows the relationship of SOLREL to other models in an integrated PV system analysis. Figure 4-8b presents a flow chart for the model. A "time event," as opposed to a failure or repair event, is either a scheduled maintenance event or the passage of a time interval over which the program reports the system status.

Because the program uses the GASP IV simulation package, which contains many special features, the user will need a GASP IV reference for the package to employ the model to its fullest potential. The body of the code is in CDC compatible FORTRAN. Some changes to this version of FORTRAN may be needed for other computer systems.

This model can be summarized as a reliability and availability analysis model for PV systems that allows the user to keep track of system failures, downtime, maintenance costs, and energy output.

H. SOLAR ENERGY SYSTEMS ANALYSIS MODEL (SOLSYS)

The SOLSYS model was originally developed by Sandia National Laboratories in the mid 1970s to simulate the performance of solar thermal energy systems (Edenburn, 1975). The SOLSYS model has recently been revised in a number of ways (Edenburn, 1981). SOLSYS has traded the economic and optimization capabilities of SOLCEL-II for a more comprehensive system performance and thermal analysis capability, which enables combined PV-thermal systems to be analyzed. This thermal analysis capability stands out as the main feature of the model. The performance model, excluding the thermal analysis, resembles that used in some of the other models such as SOLCEL-II and TRNSYS/ASU.

The SOLSYS model (Figure 4-9) consists of concentrating and non-concentrating array models; an electrical subsystem model that includes a cell model, battery model, and power conditioning models; evaporative and dry-cooling models; and a model that determines solar azimuth and elevation angles and reads typical meteorological year (TMY) data tapes.

Two electrical subroutines use the cell illumination and temperature calculated by one of the thermal models to determine electrical output. The first computes maximum power-point electrical output from the array by adjusting cell efficiency to account for cell temperature and then multiplying the adjusted efficiency by the cell illumination. The second model generates an array I-V curve by modeling a cell as a parallel light-generated current source and diode in series with a resistance. Array power, voltage, and current are taken from the I-V curve for one of four control methods: maximum power tracking, fixed voltage, battery-imposed voltage, or a quadratic voltage-current relation. Array power is reduced by a power conditioning efficiency that depends on power level. Power is fed to the load through a second power conditioning function or to an optional battery. Energy flows, including energy from the array, excess energy, and makeup energy are then tabulated and integrated.

A distinction of this model is its use for solar thermal applications, e.g., evaporative and dry-cooling tower models. The evaporative model is for a closed-loop liquid chiller that returns coolant to the array at a temperature that depends on inlet temperature, wet-bulb temperature, and the chiller's performance factor. The dry cooling tower model is similar, except that its calculations are based on dry-bulb rather than wet-bulb temperature.

The program was written in FORTRAN and is designed to operate on main-frame computer equipment.

It should be noted that the original SOLSYS model contained a model called PVSS (Goldstein and Case, 1977), which was also an element of SOLCEL-II. The newer version replaces the PVSS submodels by models that require less input and run faster. Thus, the current SOLSYS program contains no economic methodology and cannot optimize systems. However, while SOLSYS is not as comprehensive in modeling details of system performance, it has more extensive thermal modeling than SOLCEL-II to permit the study of combined PV-thermal systems.

1. Cell Characteristics

Cell temperature is modeled in great detail for flat-plate arrays, one-axis concentrator, and two-axis concentrators. Flat-plate arrays can be passively cooled (from one or both sides) or actively water cooled (including optional back insulation and zero-, one-, or two-cover glazings). The concentrator options include passive cooling, or active cooling using water, or water mixed with 30% or 50% ethylene-glycol. Active cooling can be accomplished using an evaporative cooling tower or a dry (liquid to air) heat exchanger (the former uses wet-bulb temperature while the latter uses dry-bulb). Passively cooled options may include fins on the back surface. Row-to-row shading is included in the thermal analysis although not in the performance analysis.

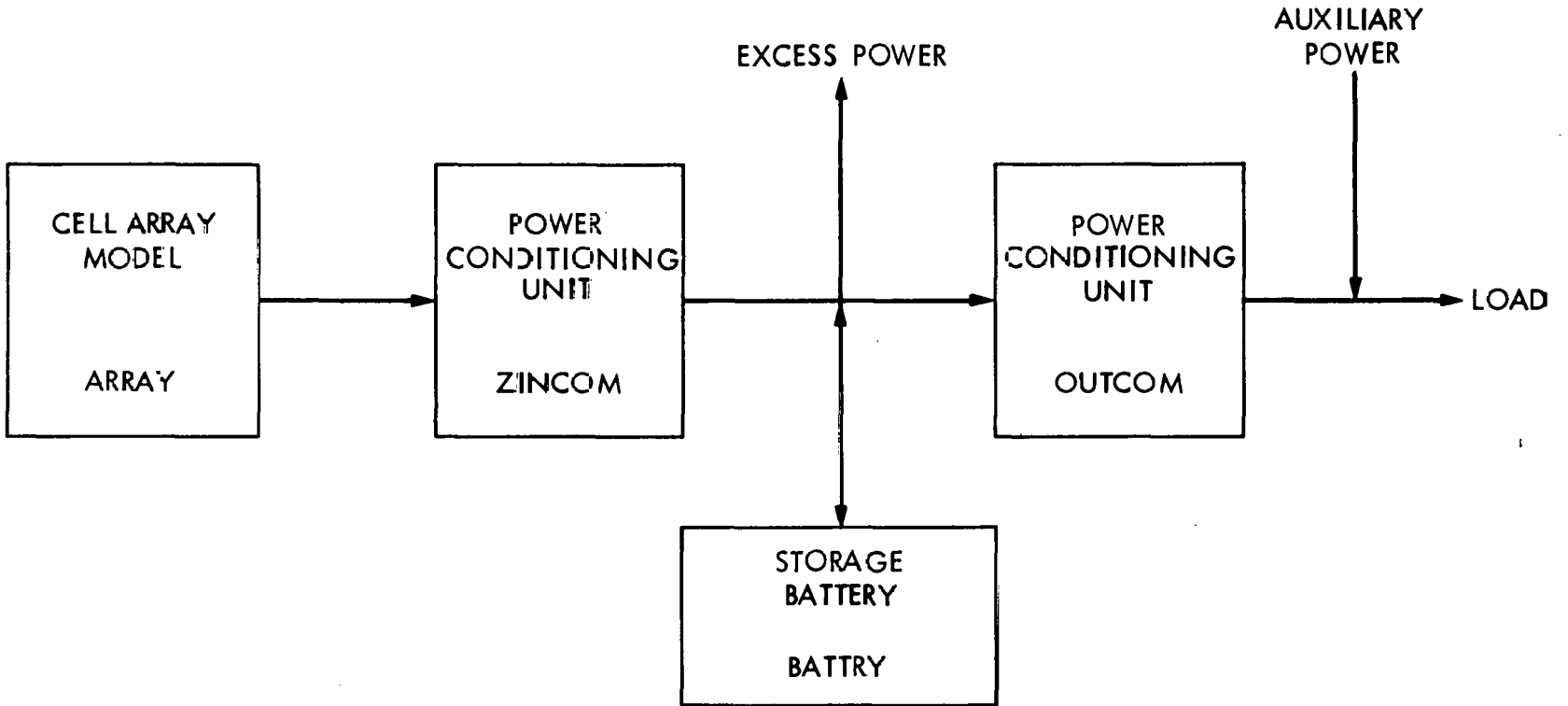

Figure 4-9. Solar Energy Systems Analysis Model Structure (Source: Edenburn, 1980)

Cell I-V information is used to determine power output. The I-V curve is modeled by an exponential equation based on insolation and temperature, a reference short-circuit current, open-circuit voltage point, and illumination. The curve is then fitted to a reference I-V point for the cell by adjusting the series resistance. This approach is essentially the same as that described by Evans (1978) for the TRNSYS/ASU model. While both approaches were drawn from PVSS (Goldstein and Case, 1977), the TRNSYS/ASU version required fitting two parameters for accuracy at high concentrations, whereas the SOLSYS model fits one parameter (series resistance). At higher concentrations, the inputs to the one-parameter curve-fitting technique must be examined carefully to ensure that the effects of increased concentration will not generate values outside the range of the curve fit.

Neither cell failures, electrical mismatch, or degradation are addressed in this model. PV system performance, therefore, does not decay over time.

Because module and array performance are scaled-up versions of cell performance, a discussion of module characteristics is not included for this model.

2. Orientation and Geometric Characteristics

SOLSYS includes models for several orientation options for flat-plate arrays, and line focus, and point focus concentration arrays. For flat-plate arrays the user may define: fixed tilt at any azimuth, two axis tracking or tilted and tracking on a vertical axis. Monthly adjustable fixed flat-plate options are not included. One-axis tracking, on either a north-south or east-west axis, is not addressed for flat-plate arrays. Line focus concentrators may be defined as: one-axis horizontal tracking, on either a north-south axis, east-west axis, or two-axis tracking. Point focus arrays are two-axis trackers. Standard geometric formulations, such as those used in SOLCEL-II, TRNSYS, LCP and PVPM, are used to determine the angle between the sun and the arrays.

3. Array-Level Characteristics

Array current is based on the chosen voltage control method (see below) and the resulting voltage. The number of cells in series and parallel in the array is input by the user. Array current is the product of the number of cells in parallel and the cell current; array voltage is cell voltage multiplied by the number of cells in series. Array power output is then determined.

An option also exists to use a simpler model than the one described under "Cell Characteristics" in which cell efficiency is assumed to be a linear function of cell temperature. Array power is then calculated as the product of that efficiency, cell illumination, and cell area.

Array electrical mismatch is not addressed in the performance model. However, models are available for calculating shading for fixed, two-axis tracking, and one-axis north-south and east-west tracking arrays.

4. Power Conditioning Unit Characteristics

SOLYSYS includes three voltage control methods: maximum power tracking, fixed voltage regulations, and voltage fixed at battery voltage. In each case an iterative procedure is used to determine current (both current and voltage in the case of maximum power tracking.) In addition, there is an option that is implemented by an iterative method which requires that current be a quadratic function of voltage.

PCU efficiency is based on a constant power loss and a loss proportional to the input power. Two separate subroutines are used to convert the power. The first is a dc to dc conversion process which filters out power beyond the PCU rating; the second is a dc to ac inverter. The user inputs rated efficiency, full load efficiency, and a constant loss for power conditioning for each PCU component, as well as an efficiency for the first component when rated power is exceeded. If supply exceeds demand, the energy is stored in the batteries; if the batteries are full, excess power is dissipated (the program keeps track of dissipated power). If energy available from the PV system (including the battery) is less than demand, auxiliary power is brought in.

5. Plant-Level Characteristics

Excess energy is assumed to be stored in lead-acid batteries. A subroutine determines the current flow from the battery and the state of charge. Discharge current is limited by a minimum terminal voltage, and current is discharged at a rate that maximizes the battery's output power.

Balance-of-system component losses are not included in SOLSYS. The load for the system is user input and is used to determine that combination of array, battery, and auxiliary power that is needed. The auxiliary power source is not defined since an economic analysis is not done in the model.

As mentioned above, SOLSYS does not consider losses due to dirt accumulation, failures, or other operational performance degrading events. Therefore, a discussion of operations and maintenance is not included.

6. Site-Specific Characteristics

The following data are read from the TMY data tapes: ambient temperature, dew point temperature, wind speed, wind direction, direct normal radiation, total horizontal radiation, and barometric pressure. These inputs are used in the detailed thermal analysis required by the active and passive cooling models (see the cell characteristics section).

Diffuse radiation is calculated from the direct normal and total horizontal radiation. Ground reflectivity is assumed to be 0.5 for each month but could be changed through modifications to the program. Isotropic atmosphere conditions are assumed to exist throughout the year. All calculations are done based on solar time.

SOLSYS is programmed in CDC FORTRAN. Some changes to the code may be necessary for use on other computers. The dissemination of the model is no longer supported by Sandia. Documentation of the model exists (Edenburn, 1981), but tapes of the code are not available.

The model can be summarized as a detailed thermal and electrical performance model of a solar cell extended to the system level by multiplication of insolation, efficiencies, and array area.

I. TRANSIENT SIMULATION PROGRAM--ASU VERSION (TRNSYS/ASU)

The TRNSYS/ASU (our acronym for the purposes of this study) code was originally designed to model the performance of PV concentrator cells (combined electric and thermal collectors). Accordingly, the emphasis of the model was toward concentrating systems (Evans, et al., 1978) and the required level of thermal analysis detail. However, the model has been revised to perform fixed-tilt, non-concentrator simulations (Evans, et al., 1980).

The basic approach consists of detailed cell modeling of solar cell I-V curves and their performance at discrete points in time, using a two-parameter curve fit with experimental data for calibration. The thermal capabilities of TRNSYS are combined with the addition of subroutines for PV electrical modeling based on the work of Florschuetz (1976). Many capabilities are present in the TRNSYS code, which is a solar heating simulation package (Figure 4-10). TRNSYS is used to provide the computational framework to provide for control over the different subroutines; provide for converting units without internal changes to either subroutine; provide subroutines that perform standard calculations (such as radiation on a tilted surface given the insolation on a horizontal surface); and to allow the user to select a variable time frame for the simulation (minutely, hourly, 3-hourly, etc.). The TRNSYS program contains a large set of modular elements that facilitate handling of large insolation and temperature data sets for a variety of surface orientations. These capabilities make the program adaptable to PV analyses and provide a framework for extensions. There is extensive documentation for TRNSYS, and regular updates have been made available by the authors of TRNSYS.

1. Cell and Module Characteristics

The cell model used is based on the assumption that the cell behaves as a single diode in parallel with a current generator and a series resistance. This work builds on an earlier study involving the PVSS model (a precursor to SOLCEL-II (see Goldstein and Case, 1977)). While the single diode model (used in PVSS and SOLCEL-II) has the benefit of simplicity and gives acceptable calculations of peak power efficiency and open circuit voltage, it may give poor representations of I-V curves at high concentrations on silicon concentrator cells (Evans et al., 1978). The approach here is a modification of the model to account for differences due to high concentration. The shapes of the I-V curves are fitted using a "diode imperfection factor" and series resistance as the fitting parameters to minimize the sum of squared residuals (Otterbein et al., 1978; Otterbein and Evans, 1980).

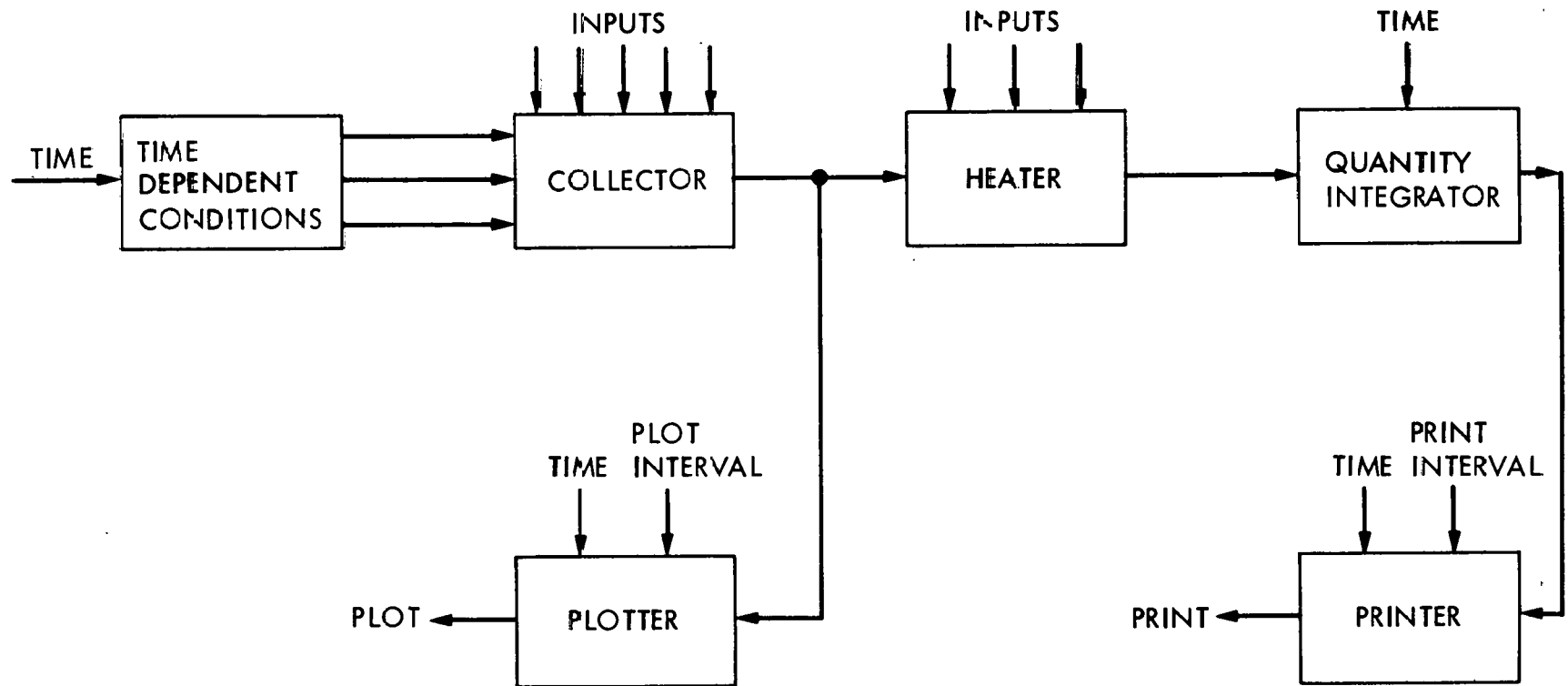

Figure 4-10. Sample Transient Simulation Program (ASJ Version) Structure (Source: Evans, et al., 1978)

The calculation of cell temperature follows the PVSS model (and SOLCEL-II and SOLSYS); temperature variations are captured by the parameter measurements used to calibrate the model.

The model does not consider cell failure analysis or degradation over time because its primary purpose is the simulation of concentrator cell performance under static conditions.

Furthermore, because the emphasis here is on cell modeling and scaling up to the system level, details at the module level are not specifically addressed. For example, module mismatch, failure analysis, degradation, or other such topics are not modeled.

2. Orientation and Geometric Characteristics

The majority of capabilities described here are inherent within the TRNSYS code and so are identical for both the ASU and MIT versions of this performance model. This subsection is described in terms of the path of incoming radiation, from available insolation through the module encapsulant onto the particular surface orientation.

As the solar beam reaches the array surface, the model allows for Fresnel refraction by the encapsulant with multiple glazings, each with its own refractive index, extinction length (thickness), and absorptance of the collector plate. The model uses Fresnel's equation for specular reflectance at a planar interface. The transmittance for diffuse radiation is approximated as the transmittance for specular radiation at an incidence angle of 60 degrees (assumed to be the average incidence angle for diffuse radiation during the day).

The TRNSYS model can simulate a variety of flat-plate surfaces, including a fixed, tilted surface at any azimuth; two-axis tracking; north-south axis tracking of optimum tilt; and east-west tracking at optimum tilt. The equations used to calculate the geometry are the standard formulations derived from spherical trigonometry. The model can also simulate a compound parabolic trough concentrating system. The model does not address tracking limits for one- or two-axis trackers, or fixed arrays having variable tilts during the year.

3. Array-Level Characteristics

The array characteristics are a scalar multiple of the PV cell performance; thus, array mismatch and series/parallel networks are not addressed. In addition, the problem of shading by adjacent arrays is not considered.

4. Power Conditioning Unit Characteristics

TRNSYS/ASU is capable of operating with a regulator/inverter to control the load interface. The model allocates proportions of power to various elements of the system (power to battery, grid, or load) with losses

due to the regulator/inverter specified as single-user input power efficiencies that reduce the available power by a fixed amount independent of load.

5. Plant-Level Characteristics/Operations and Maintenance

This model does not address balance-of-system losses. As a way of getting around this limitation, the losses could presumably be added to the regulator/inverter losses as a user-input factor. A number of load interconnects are allowed.

- (1) Mode 0: No battery with excess energy feedback to utility grid with assumed peak power tracking collector.
- (2) Mode 1: Battery model that monitors state of charge and assumed peak power tracking collector;
- (3) Mode 2: Battery model that monitors voltage level, charge/discharge rate and state of charge with assumed peak power tracking.
- (4) Mode 3: Collector voltage equal to battery voltage with current instead of power distribution while monitoring battery state of charge and voltage.

These options are primarily allocation rules for distributing power to either the load, battery, or utility grid.

The battery performance is described using a model developed by Shepherd (1965) and Hyman (1977). This model was developed for lead-acid batteries but could possibly be extended to other types if the proper input parameters were known. The model specifies how the battery voltage, state of charge, and rate of charge or discharge are related (Facinelli, 1983).

TRNSYS/ASU makes no provisions for cleaning, reliability analysis, module replacements, or costing (for operations and maintenance); so this category is not considered here.

6. Site-Specific Characteristics

Total global radiation and direct, normal radiation are required over the time period of interest. The model uses SOLMET and TMY type files for these inputs although it is not restricted to these. There are five methods for obtaining the beam and diffuse radiation:

- (1) Liu and Jordan (1960): Beam and diffuse measured from total radiation.
- (2) Boes, et al. (1976): Beam and diffuse separated using a simple linear relationship.
- (3) Bugler (1977): Diffuse estimated using clear atmosphere index relationship.

- (4) Beam and diffuse input directly from measurements (or other models).
- (5) Total and direct input directly from measurements (or other models).

All of these methods use the conventional geometry for orienting the radiation to the surface of interest. The model also requires a corresponding file of ambient air temperature that is used in the energy balance calculation to obtain cell temperature for the thermal model. If a wind-dependent model is desired, an additional input requirement is the average hourly wind speed during each time interval. This parameter is used in the thermal model and affects cell temperature. Although the model is a cell model, it is assumed that the derived temperatures also hold for the modules and array as a whole. This assumption is typically used in modeling system performance based on the thermal properties of the array. Thermally, it is the array that is modeled; the cell temperature is inferred from the array temperature, and the cell electrical behavior is then determined.

An isotropic sky condition is assumed for the diffuse component and the ground reflectivity is a constant value throughout the simulation. The program can operate in either solar or local standard time and uses the standard equations of solar position and surface orientation for these calculations.

The program is written in FORTRAN and is designed to run on a mainframe computer.

The model could be summarized as a detailed thermal and electrical model of a solar cell extended to the system level by multiplication of insolation, efficiencies (i.e., power conditioning), and area.

J. TRANSIENT SIMULATION PROGRAM--MIT VERSION (TRNSYS-MIT)

The TRNSYS/MIT model (our acronym for the purposes of this study) was developed to simulate the performance of utility-interactive residential photovoltaic energy systems. The model was designed with the goal of sufficient detail to evaluate various system design options, such as fixed voltage operation versus maximum power tracking (Hart, 1982; Hart and Raghuraman, 1982a, b,c). The model consists of the following elements:

- (1) A detailed thermal model of an array that computes cell temperature given insolation, ambient temperature, and wind speed.
- (2) A model of the electrical characteristics of the dc side of power conditioners, using array-level I-V curves.
- (3) Models of power conditioner ac output, given dc input.

Figure 4-11 illustrates the configuration of the overall model. The electrical performance characteristics are modeled using a TRW model (Luft, et al., 1967) that has been imbedded within the TRNSYS framework. The Sandstrom I-V curve model (JPL, 1976) is used to characterize the electrical performance at

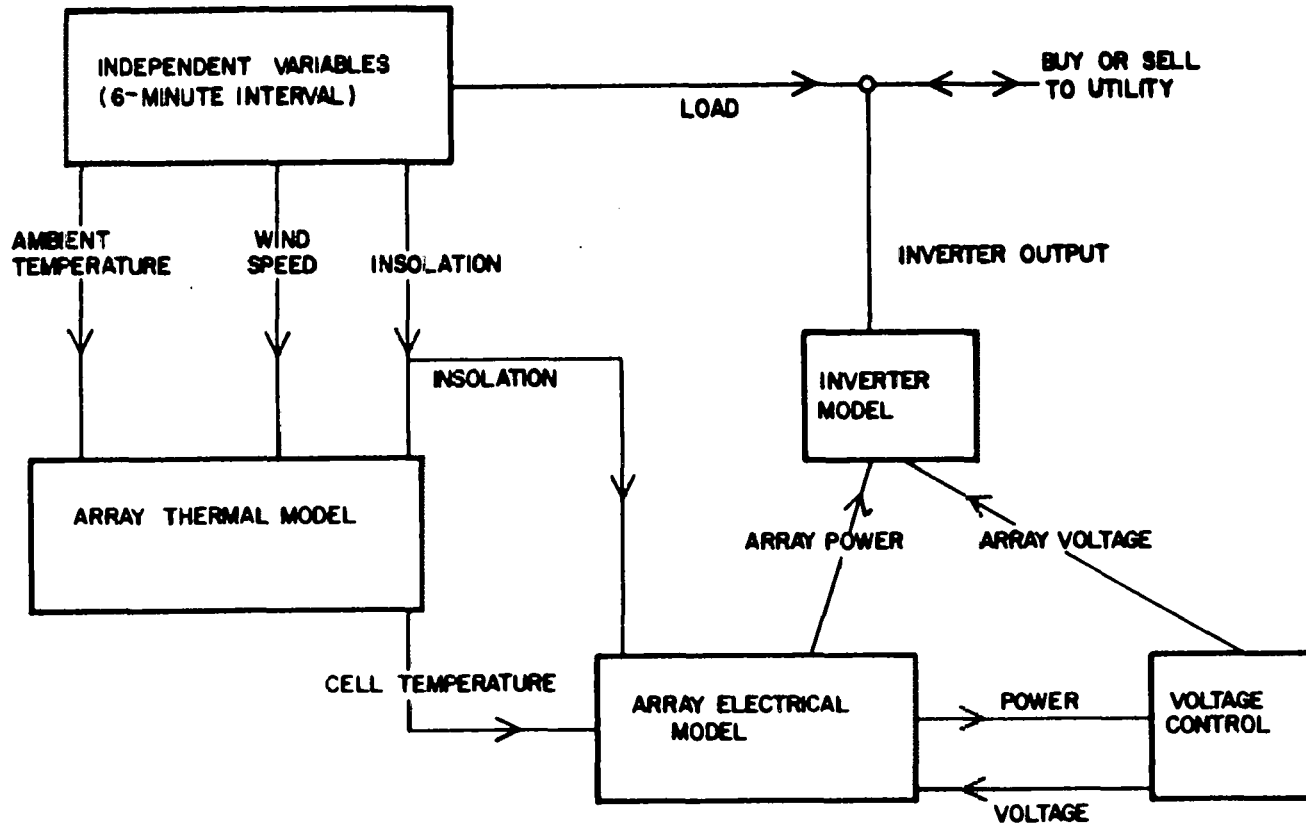

Figure 4-11. Transient Simulation Program (MIT Version) Framework
 (Source: Hart and Raghuraman, 1982b)

the array level, based on measurements of the entire array taken at experimental sites. Insolation, temperature, and wind speed data are input to an array thermal model (to calculate cell temperature) and an array electrical model. The power calculated by this component is "controlled" by feeding the results to a voltage control model, which regulates the dc output to an inverter model. The combination of array power and array voltage are used by the inverter model to generate the ac inverter output. Depending on the load, power is either bought from or sold to the interconnected utility. The PCU can be either a maximum power tracker or a fixed voltage regulator.

TRNSYS is used to establish a computational framework that provides for convergence control over the different subroutines; permits converting units without internal changes to either subroutine; uses subroutines that perform standard calculations (such as radiation on a tilted surface, given the

insolation on a horizontal surface); and allows the user to select a variable time frame for the simulation (minutely, hourly, 3-hourly, etc.). The MIT work employs time intervals of six minutes for calibrating and checking the validity of the analysis, and one-hour intervals for projecting typical annual performance. The MIT model uses the TMY and SOLMET data for this purpose.

The emphasis of the model is on examining specific design topics for residential applications in a relative fashion, using energy output as a criterion. The primary topics examined are thermal effects and a variety of PCU operational strategies. The remainder of this section describes the detailed elements of the combined model.

The model does not consider cell failure analysis or degradation over time. Because there is no modeling below the array level, cell and module characteristics are not addressed.

1. Orientation and Geometric Characteristics

The TRNSYS/MIT model does not use the Fresnel refraction capabilities of TRNSYS, but it does simulate a variety of flat-plate surfaces, including a fixed, tilted surface at any azimuth; two-axis tracking; one-axis, north-south axis tracking; and one-axis, east-west tracking. The equations used to calculate the geometry are the standard formulations derived from spherical trigonometry.

The model does not address tracking limits for one- or two-axis trackers or adjustable tilts for fixed arrays during the year.

2. Array-Level Characteristics

This is the first level of PV array performance detail in TRNSYS/MIT. As mentioned earlier, the TRW model is used to specify the array I-V, curve using three points: the open-circuit voltage, the short-circuit current, and the maximum power point. The Sandstrom model (JPL, 1976) is then used to modify the basic I-V curve for different insolation and temperature values by

scaling the axes of the curve so that the shape of the curve is preserved. Because the model is a curve-fit that preserves the shape of the aggregate array I-V curve, mismatch is not addressed. The problem of array shading from adjacent arrays is also not addressed within this model.

3. Power Conditioning Unit Characteristics

TRNSYS/MIT is capable of operating with three distinct array voltage control strategies: maximum power point tracking, fixed voltage, and a hybrid voltage control system. For maximum power tracking, the simulation searches through the I-V curve for the maximum power. The fixed-voltage approach iterates between a voltage control algorithm and the array current-voltage algorithm until a power and voltage are determined. The hybrid voltage control option varies the voltage over time in a manner corresponding to the manufacturer's inverter.

A two-dimensional linear interpolation formula is used to find the inverter efficiency as a function of dc power and dc voltage. This is basically the piecewise-linear curve fit approach used in a number of other models.

4. Plant-Level Characteristics/Operations and Maintenance

This model does not include any additional balance of system losses. Residential load is an optional input; in such a case the energy purchased from the utility and the energy sold to the utility, is calculated by a straightforward subtraction calculation as indicated in Figure 4-9. There are no provisions for cleaning, reliability analysis, module replacements, degradation, or operations and maintenance costing.

5. Site-Specific Characteristics

Total global radiation and direct normal radiation are required over a one-year period. The model uses SOLMET and TMY type files for these inputs although it is not restricted to these. There are five methods for obtaining the beam and diffuse radiation provided by the TRNSYS code:

- (1) Liu and Jordan (1960): Beam and diffuse radiation measured from total radiation.
- (2) Boes, et al. (1976): Beam and diffuse radiation separated, using a simple linear relationship.
- (3) Bugler (1977): Diffuse radiation estimated, using clear atmosphere index relationship.
- (4) Beam and diffuse input directly (from measurements or other models).
- (5) Total and direct input directly (from measurements or other models).

When the TRNSYS/MIT model was calibrated and tested at the Northeast Residential Experiment Station, total insolation data on the array surface were available, and these data were input directly.

All of these methods use the conventional geometry for orienting the radiation to the collector surface of interest. The model also requires a corresponding file of ambient air temperature that is used in the calculation of cell temperature by the thermal model. The average wind speed during each time interval is an additional input used in the thermal model that calculates cell temperature. The Sandstrom model is used to characterize the array as a large "cell." Accordingly, the temperature model assumes that the derived cell temperatures are constant across the array. There appears to be good agreement between actual measurements at the NE Residential Experiment Station and model predictions. The isotropic sky condition is assumed for the diffuse component, and the ground reflectivity is a constant value throughout the simulation.

The program can operate in either solar or local standard time and uses the standard equations of solar position and surface orientation for these calculations. The program is written in FORTRAN and is designed to run on a mainframe computer.

The model can be summarized as a detailed thermal and electrical model of a solar array for residential PV systems.

SECTION V

A SUMMARY OF MODEL CAPABILITIES AND LIMITATIONS

A. MODEL CAPABILITIES: ISSUES ADDRESSED

The 10 models included in this review span a variety of topics and range from first-order approximations of PV system performance to in-depth, circuit-level descriptions of a PV system. Although models designed to perform different functions are difficult to compare, they often are compared. This report places such comparisons in context. By examining individual model capabilities on a uniform basis, the strengths, weaknesses, and purposes of a model are more clearly defined. These capabilities are summarized in Tables V-1 through 5-8, which display the features of each model in a matrix of characteristics. Each table represents one of the major topic areas identified in Section III and the attributes or characteristics of each topic are the column headings within the Table. It is at this point that the models are reviewed in terms of their capabilities, i.e., how they address the topic areas. For a more detailed account of any particular model, the reader is referred to the detailed summary of that model in Section IV. The model capabilities are described in the context of the following topics: Cell-Level, Module-Level, Orientation and Geometric, Array-Level, Power Conditioning Unit, Plant-Level, Operations and Maintenance, and Site-Specific Characteristics. The entries in the tables are defined in terms of whether the capability is analytically modeled within the code and whether the capability is a user input value or set of values that are generated externally. An "N/A" entry in the tables has two meanings. One is that the capability is "not addressed" or that it is "not applicable." The "N/A" entry does not necessarily imply that the capability was erroneously ignored. Rather, the model may have been designed to emphasize some other area, and thus the capability is not required.

1. Cell Characteristics (Table 5-1)

All the PV performance models described in this report address cell temperature and its effect on cell efficiency. There are two basic categories into which the calculations of cell temperature fall. Models in the first category employ a linear relationship between air temperature, insolation at the array, cell temperature, and in some cases, wind speed, as in E&R, LCP, PV F-CHART, and PVPM. In the second category of performance models (SOLCEL-II, SOLSYS, TRNSYS/ASU, TRNSYS/MIT), detailed thermal analyses are performed, solving heat transfer energy balance equations. These capabilities were developed primarily to describe concentrating systems with heat transfer loops. An exception is TRNSYS/MIT, which is concerned with thermal modeling of flat-plate systems for residential roof applications. Here the concern may be satisfactory treatment of residential arrays direct-mounted to the roof.

Cell efficiency is also modeled in two basic forms, either as a function of cell temperature or a function of the cell I-V curve. PV-TAP, SOLSYS, and the TRNSYS/ASU model have the most detailed cell I-V curve descriptions. The E&R model does performance modeling based on a I-V curve for any specified network (usually at the array level). TRNSYS/ASU is unique in that it requires fitting two parameters for the I-V curve (see Section IV-I).

Table 5-1. Model Capabilities: Cell Characteristics

MODEL	Cell IV Curve	Cell Mismatch	Cell Failures	Cell Temperature
E&R	user inputs pairs of I-V values. Curves are aggregated to desired level	mismatch submodel aggregates actual I-V curves either deterministically or statistically	cell failure submodel uses cell failure rate to identify open and short circuit I-V curves	analytic model: linear relation using air temperature, solar radiation, and wind speed
LCP	user inputs pairs of I-V values. I-V curves are aggregated to desired level. Based on E&R model	N/A at cell level (see module level)	analytic model: random failures with input failure rate. Failures affect array degradation rate. (Ross et al. 1980)	analytic model: linear relationship using air temperature and solar radiation
PV F-CHART	N/A	N/A	N/A	analytic model: linear relation using air temperature and solar radiation
PVPM	N/A	N/A	N/A	analytic model: linear relationship using air temperature and solar radiation
PV-TAP	analytic model: detailed electrical circuit analysis which keeps track of individual I-V curves at cell, module, or array level	analytic model: extensive circuit analysis capability using Ebers-Moll formulation and descriptive representation	N/A	analytic model: detailed thermal analysis for cell temperature using electrical network equivalent of thermal heat flow
SOLCEL-II	no analytic model for cell I-V curve: current voltage parameters are specified inputs used with cell temperature to calculate maximum power point using basic diode circuit	N/A	N/A	analytic model: detailed thermal analysis for average cell temperature; cell temperature a function of air temperature, solar radiation, and wind speed
SOLREL	N/A	N/A	user input: degradation curves based on cell failure rate are input	N/A
SOLSTS	analytic model of cell and an exponential equation based on weather characteristics	N/A	N/A	analytic model: detailed thermal analysis for cell temperature; cell temperature a function of air temperature, solar radiation, and wind speed
TRNSYS/ASJ	analytic single diode model of cell	N/A	N/A	analytic model: based on thermal efficiencies of collector
TRNSYS/MIT	N/A at cell level (see array level)	N/A	N/A	analytic model: detailed thermal analysis for cell temperature; cell parameters calculated directly using Sandstrom model (JPL, 1976)

Most of the models do not incorporate cell level properties other than thermal effects. The effect of cell failures on performance is only included in the E&R and LCP models. Inter-cell electrical mismatch is examined only in PV-TAP, which functions on a circuit level. Other models address electrical mismatch at more aggregate levels or not at all.

2. Module Characteristics (Table 5-2)

Several of the models in this review make no distinction between the cell and module levels. In SOLCEL-II, SOLSYS, TRNSYS, PVPM, and PV F-CHART, module failures, replacement, degradation, and bypass diode placement are not considered. The E&R, LCP, PV-TAP, and SOLREL performance models address these topics in several ways.

The E&R reliability model addresses module degradation and failure due to cell failures as well as module electrical mismatch. The series/parallel wiring design and bypass diode placement are all user inputs that permit the model to keep track of the module I-V curve status. Module replacement, however, is not addressed.

LCP examines the module level in detail. Cell failures are modeled in the same manner as the E&R model. The user inputs a series/parallel wiring design specification for the module, including bypass diodes. Electrical mismatch is included in the aggregation of I-V curves where each successive aggregation includes the electrical mismatch from previous levels. Module degradation and dirt accumulation are also considered.

PV-TAP does not address module failure, degradation, or replacement, but it does address electrical mismatch and wiring design in detail. The circuit network, which is input by the user, includes bypass diodes at the cell, module, or array level. The model keeps track of each circuit, including mismatch between circuits.

SOLREL accepts a constant percentage degradation rate due to cell failures for each year, which is applied to system output.

3. Orientation Geometric Characteristics (Table 5-3)

Most of the performance models can simulate a variety of system configurations for fixed or tracking flat-plate arrays and line or point-focus concentrating arrays. Only PV F-CHART is limited to fixed, flat-plate arrays, but these can be oriented at any tilt or azimuth angle. The other models use standard geometric formulations to simulate one- and two-axis tracking flat-plate or concentrating arrays as well as fixed arrays. Notable exceptions are E&R and LCP, which do not handle concentrating arrays. SOLSYS does not simulate north-south and east-west single-axis tracking, flat-plate arrays. See Table 5-3 for a complete comparison of all the orientation options for the models.

The E&R performance model, LCP, and the TRNSYS/ASU models have the additional capability to model Fresnel refraction of the module encapsulant.

Table 5-2. Model Capabilities: Module Characteristics

MODEL	Series/Parallel Specification	Bypass Diodes	Module Mismatch	Module Failure	Module encapsulant Refraction (Fresnel vs. Cosine)	Module Degradation
E&R	user input network design which affects array power degradation and failures	analytic model with user input no. of diodes per series block	analytic model sums I-V curves to account for mismatch	analytic model: stochastic failures at substring level and effect on I-V curves	analytic model (Fresnel) for encapsulant refraction based on surface orientation and sun position	analytic model based on exponential aging and failures over time
LCP	user input network design which affects power degradation and failures	analytic model with user input no. of diodes per series block	analytic model sums I-V curves to account for mismatch	analytic model: modules are considered failed when power output falls below a user defined level	analytic model (Fresnel) for encapsulant refraction based on surface orientation and sun position	analytic model based on exponential decay or probabilistic model based on cell failure and effect on module I-V curve
PV F-CHART	N/A	N/A	N/A	N/A	N/A	N/A
PVPM	N/A	N/A	N/A	N/A	N/A	N/A
PV-TAP	user input network which keeps track of individual circuit elements	analytic model: diodes incorporated at the cell, module, or array level. Their number and placement are tracked individually or statistically	analytic model: extensive detail at cell, module, or array level depending on user's specifications	N/A	N/A	N/A
SOLCEL-II	N/A - module performance a multiple of cell performance	N/A	N/A	N/A	N/A	N/A
SOLREL	N/A	N/A	N/A	user input: mean time between failures used if E&R performance model not used for input	N/A	user input: percentage degradation losses are input
SOLSYS	N/A - module performance a multiple of cell performance	N/A	N/A	N/A	N/A	N/A
TRNSYS/ASU	N/A - module performance a multiple of cell performance	N/A	N/A	N/A	analytic model capable of multiple glazings each with a refractive index	N/A
TRNSYS/MIT	N/A (see array level)	N/A	N/A	N/A	N/A	N/A

Table 5-3. Model Capabilities: Orientation and Geometric Characteristics

MODEL	-----Flat Plate-----					-----Concentrators-----				Adjustable Tilt Capability for Non-tracking Systems	Variable Start Up/Shut Down Times for Tracking Systems
	Fixed Tilt	2-Axis Tracking	North/South Axis Tracking	East/West Axis Tracking	Vertical Axis Tracking	2-Axis Tracking Fresnel Lens	EW Linear Trough	NS Trough	Compound Parabolic Trough		
E&R	analytic model of fixed surface orientation--any azimuth	analytic model of arbitrary surface orientation	analytic model of arbitrary surface orientation by varying orientation hourly	analytic model of arbitrary surface orientation by varying orientation hourly	N/A	N/A	N/A	N/A	N/A	user inputs monthly tilt angle	NA
LCP	analytic model of fixed surface orientation--any azimuth	analytic model of 2-axis tracking	analytic model for N/S tracking (any tilt)	analytic model for E/W tracking	analytic model for vertical tracking	N/A	N/A	N/A	N/A	user inputs monthly tilt angle	user inputs start and stop angles (from solar noon)
PV F-CHART	analytic model of fixed surface orientation--any azimuth	N/A	N/A	N/A	N/A	N/A	N/A	N/A	N/A	N/A	N/A
PVPM	analytic model of fixed surface orientation--any azimuth	analytic model of 2-axis tracking	analytic model for N/S tracking (horizontal only)	analytic model for E/W tracking	N/A	analytic model of point focus concentrators	analytic model of line focus E/W tracking	analytic model of line focus N/S tracking	N/A	N/A	N/A
PV-TAP	analytic model for south facing azimuth and direct component	analytic model of gain multiplier x direct solar radiation x incidence factor	analytic model of gain multiplier x direct solar radiation x incidence factor (horizontal only)	analytic model of gain multiplier x direct solar radiation x incidence factor	N/A	analytic model of gain multiplier x direct insolation x incidence factor	analytic model of gain multiplier x direct insolation x incidence factor	analytic model of gain multiplier x direct insolation x incidence factor	analytic model of gain multiplier x direct insolation x incidence factor	N/A	user input: sun elevation angle required to minimize shading
SOLCEL-II	analytic model of fixed surface orientation--any azimuth	analytic model of 2-axis tracking	analytic model of N/S tracker (any tilt)	analytic model of E/W tracker	analytic model of vertical tracker	analytic model of point focus collector	analytic model for E/W line focus tracking	analytic model of N/S line focus tracking	N/A	N/A	user input: sun elevation angle required to minimize shading
SOLREL	N/A	N/A	N/A	N/A	N/A	N/A	N/A	N/A	N/A	N/A	N/A
SOLSYS	analytic model of fixed surface orientation--any azimuth	analytic model of 2-axis tracking	N/A	N/A	analytic model for vertical tracking	analytic model of point focus collector	analytic model of E/W line focus tracking	analytic model of N/S line focus tracking	N/A	N/A	N/A
TRNSYS/ASU	analytic model of fixed surface orientation--any azimuth	analytic model of 2-axis tracking	analytic model for N/S axis tracker	analytic model for E/W tracker	N/A	analytic model of Fresnel lens (2-axis)	N/A	N/A	analytic model of collector optics	N/A	N/A
TRNSYS/MIT	analytic model of fixed surface orientation--any azimuth	analytic model of 2-axis tracking	analytic model for N/S axis tracker	analytic model for E/W tracker	N/A	N/A	N/A	N/A	N/A	N/A	N/A

This model takes into account the bending of the solar radiation as it passes through the encapsulation material. The refractive index of the material must be supplied by the user.

4. Array-Level Characteristics (Table 5-4)

As was the case with module level characteristics, some of the models make a limited distinction between the cell level and the array level in terms of performance. For example, the cell-level characteristics (temperature and performance) are scaled up to the array size in the SOLCEL-II, SOLREL, TRNSYS/ASU, PVPM, and PV F-CHART models. A common assumption used in all these models is that the derived cell temperature is assumed to hold for the modules and array as a whole. In SOLSYS, the array performance is the cell performance multiplied by the appropriate number of series and parallel cells. TRNSYS/MIT operates on the array I-V curve rather than a cell I-V curve. None of these models mentioned above include array-level series/parallel wiring specification for inter-array electrical mismatch.

The E&R model and LCP both accept the array series/parallel wiring pattern as input and use it to determine electrical mismatch between arrays. Cell temperature is aggregated to the array level as in the models described above. PV-TAP performs a detailed circuit analysis, which tracks electrical performance on all levels.

Only E&R, LCP, and SOLCEL-II (in an extension of the original code) address inter-array shading on an hour-by-hour basis. PVPM utilizes a user-input miscellaneous loss factor which represents annual average shading efficiency. PV-TAP addresses cloud shading based on user inputs, but not inter-array shading as an internal model (see Section IV-E).

5. Power Conditioning Unit Characteristics (Table 5-5)

A wide variety of power conditioning unit models were examined in this study. These ranged from modeling the subsystem as a single efficiency input to detailed simulations, including various voltage control methods, multiple inverters, hybrid inverters, and load dependent efficiencies. SOLCEL-II fits the latter description because it includes maximum power tracking, fixed-voltage regulation, and floating battery voltage control. It can also model two PCUs, each with the same efficiency curve. SOLSYS also has a detailed PCU model although it does not handle multiple inverters; it contains various voltage control options and a load-dependent efficiency. The E&R model contains a detailed PCU simulation as well with fixed voltage, seasonally adjusted voltage, frequently adjusted voltage, and maximum power tracking options. TRNSYS/MIT is similar to SOLSYS except that it includes a load-dependent efficiency curve.

LCP and PVPM both include a load-dependent power conditioning efficiency but do not allow for voltage regulation. LCP interpolates the PCU efficiency based on a set of input piecewise-linear curves, while PVPM uses a non-linear function of power output.

TRNSYS/ASU and PV F-CHART both treat the power conditioning subsystem as a constant efficiency power conversion device.

Table 5-4. Model Capabilities: Array-Level Characteristics

MODEL	Series/Parallel Network Specification	Array Electrical Mismatch	Array Shading
E&R	user input	analytic mismatch submodel aggregates I-V curves either deterministically or statistically	analytic models for fixed arrays and N/S axis tracking arrays
LCP	user input number of series and parallel strings	mismatch included in I-V curve model as cells fail (see module level)	analytic models for fixed arrays and N/S axis tracking arrays
PV F-CHART	N/A user inputs array area	N/A	N/A
PVPM	N/A	N/A	user may input a constant annual percentage loss for inter-array shading
PV-TAP	analytic model tracks individual elements	analytic model output currents are limited by smallest photocurrent in series	user input as zero voltages (zero direct insolation) for elements in shadow
SOLCEL-II	N/A	N/A	analytic model contained in external routine to SOLCEL-II
SOLREL	N/A	N/A	N/A
SOLSYS	array level power is scaled up from user input series/parallel configuration and cell power	N/A	N/A
TRNSYS/ASU	N/A--scalar multiple of cell performance	N/A	N/A
TRNSYS/MIT	N/A--model based on array level I-V curve for single PCU	N/A directly other than in calibration	N/A

Table 5-5. Model Capabilities: Power Conditioning Unit Characteristics

MODEL	-----Voltage Control-----			Multiple Inverters	Form of Power Output Calculation
	Maximum power Tracking	Fixed Voltage	Floating Battery		
E&R	analytic model of either fixed or continuous voltage tracking	modeled analytically using I-V curves to estimate fill factor and power out at SOC.	N/A	N/A	user input efficiency: piecewise linear PCU efficiency curve interpolated based on fraction of peak PCU power
LCP	N/A--(assumes maximum power tracking)	N/A	N/A	N/A	efficiency interpolated user input piecewise linear PCU efficiency curve. Interpolation based on fraction of peak PCU power
PV F-CHART	N/A (assumes maximum power tracking)	N/A	N/A	N/A	user inputs PCU efficiency as a single value
PVPM	N/A--(assumes maximum power tracking)	N/A	N/A	N/A	PCU efficiency is calculated as a function of power
PV-TAF	analytic model based on electrical circuit of power tracker. Input for response time constant is required	N/A	analytic model using battery as circuit element to regulate transients	N/A	N/A
SOLCEL-II	analytic model for maximum power tracking. Includes efficiency for tracker based on Voc and Isc inputs	analytic model based on battery model w/fixed voltage (= batt. volt.)	user can fix array voltage to battery voltage	user input efficiency curve which simulates 2 identical inverters	user input PCU efficiency curve. PCU overloads (output = 0) if rated size is exceeded by 10% for any hour
SOLREL	N/A	N/A	N/A	N/A	N/A
SOLSYS	analytic model by iterating through voltage equation until maximum power is achieved	analytic model which iterates voltage equation to find current and power	analytic model ties array and battery voltage together through iteration of voltage equation	N/A	can require current to be specified function of voltage via iterations of equations. PCU losses are a combination of a loss proportional to power output and a constant power loss
TRNSYS/ASU	user input single regulator/inverter efficiency in "no storage" mode	user input single regulator/inverter efficiency in clamped voltage mode with battery	analytic model can tie array and battery voltage together through iteration of voltage equation	N/A	user inputs PCU efficiency as a single value
TRNSYS/MIT	analytic model using search over I-V curve based on insolation and temperature (Array Design Handbook, 1976) to find maximum power point	analytic model which iterates between voltage control and array I-V curve	N/A	N/A	interpolation formula used to find efficiency on PCU efficiency curve. Also includes hybrid voltage control PCU

6. Plant-Level Characteristics (Table 5-6)

Additional losses associated with the balance-of-system (BOS) are explicitly addressed in three of the models: LCP, SOLCEL-II, and PV F-CHART. In LCP, the BOS efficiency is a constant input by the user which reduces system output. PV-TAP performs a detailed analysis including wiring, connections, and parasitic losses. SOLCEL-II details parasitic losses due to cooling water pumping and tracking motors calculating these losses internally. The other models do not address BOS efficiency as a separate item. Although not specifically called out, one could aggregate the BOS losses in with other losses in some of the models.

The E&R, PVPM and TRNSYS/ASU performance models do not address utility interconnection and battery storage. LCP provides for either a specific input load or a utility interconnection but for a battery. For grid-connected applications, LCP allows a choice of either a central station or distributed system, with parallel or simultaneous utility connection. PV-TAP allows for a battery, not a utility, interconnection.

The SOLCEL-II and SOLSYS models allow for various modes of interconnection between the PV system and the utility, battery storage, and/or load. The combinations include using the battery as the primary backup, using the utility as the primary backup with battery storage, or using no battery storage or backup. TRNSYS/MIT describes residential/utility interconnection, a primary purpose of the model, in some detail. See the detailed descriptions of Section IV for the individual model capabilities.

7. Operations and Maintenance (Table 5-7)

Operations and Maintenance is a performance issue addressed by only a few of the models. Models that do not include subsystem failures or degradation do not include O&M activities either. Only LCP and SOLREL address O&M in the performance calculations. PV F-CHART and SOLCELL-II do not address performance related O&M issues directly, but the user can input cost factors accounting for insurance and maintenance costs in the life-cycle cost models. These are input as a constant annual amount for the first year and then escalated by the model over the system lifetime, or O&M expenditures can be estimated.

In LCP, the user may define the number of cleanings accomplished manually or by rainfall monthly. The variable effects of these cleanings are included in the estimation of total energy output. The user may also define costs for maintenance activities either as single occurrences or recurring events. The costs are included in the total life-cycle cost streams. Module replacements can be made via one of two options from which the user can choose. The effect of BOS downtime on system performance and operations and maintenance costs are estimated on an annual basis. The model outputs a cost accounting of all O&M activities over the system lifetime.

O&M is the main focus of the SOLREL model. It performs a detailed availability analysis based on inputs of mean times between failures and mean times to repair. Energy output curves, which SOLREL accepts as an input, are modified for outages due to subsystem failures.

Table 5-6. Model Capabilities: Plant-Level Characteristics

MODEL	Balance of System	Utility Load/ Interconnect	Battery Storage
E&R	N/A--see PV F-CHART	analytic model of generic load on PCU - energy not explicitly separated for sellback	N/A
LCP	user input constant for wiring, connection and parasitic losses	user may define: <ul style="list-style-type: none"> - utility ownership - 100% sell back - excess PV sellback over customer lead 	N/A
PV F-CHART	N/A (could be combined with PCU efficiency)	user may define: <ul style="list-style-type: none"> - 100% sellback - excess to battery - excess dissipated 	user input loss for battery charge/discharge; dissipated energy a function of battery capacity
PVPM	user inputs a percentage loss factor	N/A	N/A
PV-TAP	input constants for either wiring, connection, and parasitic resistances; or single user input resistance	N/A	analytic model: <ul style="list-style-type: none"> - power storage model - transient response model
SOLCEL II	analytic model of parasitic losses calculated by model for active cooling and tracking	3 analytic models: <ul style="list-style-type: none"> - PV, battery, then utility backup - PV, battery, then diesel backup - all PV to load, no storage - one year of hourly load data is required 	analytic model based on charge-discharge characteristics of advanced lead acid battery
SOLREL	N/A	N/A	N/A
SOLSYS	N/A	load is user-supplied. Output power is allocated to storage or load as required	analytic model for battery using an open circuit voltage that depends on its state of charge and a voltage drop that depends on resistance and charge/discharge rate
TRNSYS/ASU	N/A	4 modes: <ul style="list-style-type: none"> - utility feedback/ no battery - battery model/peak power tracking - battery model w/ voltage and state of charge - fixed voltage interconnect 	analytic model of level acid battery (Facinelli, 1983)
TRNSYS/MIT	N/A	analytic model for residential load (optional) and buy/sellback decision	N/A

Table 5-7. Model Capabilities: Operations and Maintenance Characteristics

MODEL	Cleaning	Reliability	Module Replacements	O/M Costing
E&R	N/A	Ross, 1980 cell failure analysis model for failure profile over lifetime	N/A	life-cycle cost model (Ross, 1978)
LCP	user input cleaning schedule with restoration multiplier for cleaning quality	Ross, 1980 cell failure analysis model for failure profile over lifetime and balance-of-system downtime	analytic model: replacement made when a critical number of failures (user defined) occur in module or system power falls below a user defined threshold	user may input costs for O&M activities. Costs are escalated over time for input to external financial analysis (Borden, 1983)
PV F-CHART	N/A	N/A	N/A	life-cycle cost model (Duffie and Beckman, 1980)
PVPM	N/A	N/A	N/A	N/A
PV-TAP	N/A	N/A	N/A	N/A
SOLCEL-II	N/A	N/A	N/A	costing based on either life-cycle costing (Perino, 1978) or DOE/EPRI required revenue methodology (Doane and O'Toole, 1976)
SOLREL	N/A	detailed reliability analysis based on a probabilistic analysis using user-input mean-times-between failure and mean-times-to-repair for equipment	N/A	costing based on fixed and variable repair costs
SOLSYS	N/A	N/A	N/A	N/A
TRNSYS/ASU	N/A	N/A	N/A	N/A
TRNSYS/MIT	N/A	N/A	N/A	N/A

A user interested primarily in O&M modeling should refer to the appropriate sections of Section IV for more detailed descriptions of the capabilities of the LCP and SOLREL models.

8. Site-Specific Characteristics (Table 5-8)

All the performance models use insolation and temperature data for their energy output calculations. With the exception of PV F-CHART, these data are supplied to the model externally from data tapes (e.g., TMY or SOLMET data). PV F-CHART contains data for 244 cities internally that can be accessed by the user. These data are based on historical data that have been collected or modeled for each site (see Section IV-C).

E&R, LCP, SOLSYS, SOLCEL-II, TRNSYS/ASU, and the TRNSYS/MIT model can use inputs for direct normal insolation and total horizontal insolation. PV-TAP uses only the direct normal component, while the E&R performance model uses only the total horizontal insolation. In PVPM the user may specify the use of either total horizontal, direct normal, or plane-of-array insolation.

The E&R, SOLSYS, SOLCEL-II, TRNSYS/ASU, and TRNSYS/MIT models can accept hourly average windspeed as an input for thermal analysis. For the most part, these models use SOLMET wind data, which is measured 10 meters above the ground (it is not clear how accurately these data portray windspeeds at the array height).

LCP allows the user to input module power reduction rates (based on dirt accumulation) and ground reflectivity on a monthly basis. Other models either do not address these issues or treat them as constants.

The E&R and LCP performance models include the option of anisotropic (non-uniform) scattering of diffuse radiation. The other models assume isotropic atmospheric conditions or uniform scattering of diffuse radiation. The anisotropic model assumes directional scattering from the circumsolar and horizon areas of the sky and from the ground. These two models also allow for the use of either solar time or local standard time, as do PVPM and the TRNSYS models. The remaining performance models are limited to solar time with the exception of PV-TAP, which relies on the user to coordinate the time scale of the input data with the time scale of the model.

B. MODEL LIMITATIONS: RECENT EXTENSIONS AND OPEN TOPICS

During this study a number of system-level issues were identified as areas of current and future investigation. Although these areas may not be all-inclusive, they are an indicator of the current topics of interest in the area of PV performance modeling.

All of the items discussed in this subsection are open topics in the sense that they have not been studied or have had limited examination. In those cases where information was available describing recent extensions, those capabilities are recognized.

Table 5-8. Model Capabilities: Site-Specific Characteristics

MODEL	Ambient Temperature	Other Environmental Inputs	Load Data	Solar/Local Time	Time Dependent Dirt Accumulation
E&R	input file of hourly ambient temperature	hourly wind speed (optional); hourly wet bulb temperature (optional)	user specified input file of hourly values standard	analytic model of solar or local standard time	N/A
LCP	user input profile of hourly values	N/A hourly values	user input file of solar or local standard time	analytic model of fractional power loss due to dirt accumulation	user input monthly
PV F-CHART	user input-12 profiles (1 per month) of long-term monthly-average temperature using 244 sites in program	N/A	user input-12 profiles (1 per month) of average hourly load	analytic model in solar time	N/A
PVPM	user input hourly values	N/A	N/A	analytic model of solar or local standard time	N/A
PV-TAP	user input to electrical network equivalent thermal model for selected timescale	N/A	user input for selected timescale	user input--coordinate geometric calculation with data sets--time down to submicro-second level	N/A
SOLCEL-II	user input hourly values	uses hourly average windspeed over 1 year for cell temperature calculation	user input file	analytic model of solar time	N/A
SOLREL	N/A	N/A	N/A	N/A	user input percentage loss--one input for every three years
SOLSYS	user input hourly values	uses hourly average windspeed and direction for cell temperature calculation; dew point temperature for wet bulb calculation; barometer press and sky cover fraction over 1 year	user input file	analytic model of solar time	N/A
TRNSYS ASU	user specified for timescale of interest	user input hourly average windspeed for cell temperature if wind model desired	user file input	analytic model of solar or local standard time	N/A
TRNSYS/MIT	user inputs or measured values for selected timescale	user input hourly average windspeed for cell temperature calculation for selected timescale	optional residential load model or user input measured load for selected timescale	analytic model of solar or local standard time	N/A

Table 5-8. Model Capabilities: Site-Specific Characteristics

MODEL	Total Global Solar Radiation	Direct Normal Solar Radiation	-----Diffuse Solar Radiation-----		
			Atmospheric Type	Method of Calculation	Ground Reflectivity
E&R	input file of hourly global insolation for a year	analytic model of direct (modified Liu-Jordan, 1960) or user input file of hourly global insolation	analytic model for either isotropic or anisotropic diffuse component	isotropic--modified Liu-Jordan (1960) anisotropic--Klucher, 1979	user input single value
LCP	user input file of hourly global insolation for a year	analytic model of direct insolation (Boes, et al., 1976) or user input file of hourly data	analytic model for either isotropic or anisotropic diffuse component	isotropic--Boes et al., 1976 anisotropic--Klucher, 1979	user input: 12 values (1 per month)
PV F-CHART	analytic model of 12 average profiles (1 per month) calibrated by site specific inputs (244 sites in program)	analytic model using modified Liu and Jordan (1960) approach	analytic model for isotropic diffuse component	isotropic--Erbs, et al., 1982	user input: 12 monthly values (1 per month)
PVPM	hourly input file for total global insolation for period of interest	input file for direct normal insolation or analytic model using modified Liu and Jordan (1960) approach	analytic model for isotropic diffuse component	isotropic--modified Liu-Jordan, 1960	N/A
PV-TAP	user input to electrical network equivalent of photocurrent alert generator for selected time scale	analytic model of direct insolation as nonlinear voltage controlled current generator	user input network required to characterize behavior of diffuse component	user input variable voltage element required to represent diffuse	N/A
SOLCEL-II	input files for total global hourly insolation for a year	input files for direct normal hourly insolation or analytic model using modified Liu and Jordan (1960) approach (Boes, et al, 1976)	analytic model for isotropic diffuse component	isotropic--Boes et al., 1976	user input single value
SOLREL	N/A	N/A	N/A	N/A	N/A
SOLSYS	input file for total global hourly insolation for a year	input file for direct normal hourly insolation or analytic model using modified Liu-Jordan (1960) method (Boes et al, 1976)	analytic model for isotropic diffuse component	isotropic--modified Liu-Jordan (1960)	a value of .5 is included in the code
TRNSYS/ASU	user inputs total insolation for selected timescale (SOLMET and TMY)	user inputs insolation for selected timescale (SOLMET and TMY)	analytic models for isotropic diffuse or user input of measured total (which includes diffuse) for selected timescale	isotropic-- 3 analytic options: - Liu & Jordan, 1960 - Boes, et al., 1976 - Bugler, 1977, or user input	user input single value
TRNSYS/MIT	user measured inputs at experimental sites for calibration (6 min.) or TMY/SOLMET hourly insolation for a year	user input measured values (e.g. TMY or SOLMET) or analytic model using modified Liu-Jordan (1960)	analytic models for isotropic diffuse or user input of measured total (which includes diffuse) for selected timescale	isotropic-- 3 analytic options: - Liu & Jordan, 1960 - Boes, et al., 1976 - Bugler, 1977 or user input	user input single value

Although some of these recent extensions may be viewed as "minor" impacts on overall system performance, there is a critical underlying issue lurking in the background. The "minor" effects viewpoint argues that the percentage differences in system output are small enough to be within the precision of the model inputs. Thus, it is implied that the additional benefits of further modeling are small in comparison to inaccuracies or variations in input data. This argument may be loosely translated into the assumption that the distribution of energy output data from the model is symmetric at the hourly level. The chances of the estimates being high or low by some fixed amount are roughly the same whether the additional modeling is added or not. This assumption may be fallacious for the following reasons. The PV performance model may be viewed as a (nonlinear) transformation of insolation and temperature data (and system specifications) into an estimate of power or energy output. Work by Latta, et al., 1979, and Hanson and DeLuisi, 1981, have shown that the distribution of solar radiation is not symmetrically distributed during the year and can have bimodal characteristics in the case of direct normal radiation. Because insolation can be viewed as a random variable and the performance model can be viewed as a non-linear transformation of this variable, it is unclear that the distribution of model output will be a symmetric distribution at the hourly level. Thus, omission of these so-called "minor" effects must be done with great care because the biases perpetuated by the insolation inputs do not necessarily cancel out. In fact, because of possible interacting terms, the contributions from a number of these effects, taken together, could sway the results significantly in one direction or another.

For the most part, the models reviewed here assume insolation values are deterministic during the course of the analysis interval. If this were true, the argument about "minor" effects would probably hold. However, few studies have been performed to examine these effects in detail. The tendency has been to derive a long-term statistical distribution of insolation first (e.g., Hall, et al., 1978; Bray, 1979) and then use this result to exercise the performance model once (e.g., using TMY data).

The point to be made is that there are numerous topics that need further investigation, and the models reviewed here could be quite useful in performing such investigations.

1. Recent Extensions

Fresnel refraction (bending of light) by the encapsulant material has been recognized as a possible problem for some time. The TRNSYS/ASU and TRNSYS/MIT codes can handle multiple glazings (in the TRNSYS framework), and the E&R and LCP models have recently modified their programs to examine the effects of refraction. Both models employ the same approach by using an input refractive index for the encapsulant material and optical refraction equations. Additional losses of 3 to 4% have been found when the Fresnel effect is included.

Another area of recent examination is the effect of varying the time scale of the model on the results obtained. The TRNSYS/MIT model was used in a preliminary study of utility-interactive situations and found that the longer the simulation time step, the greater the underestimation of the energy

purchased from and sold to the utility (Hart, 1982). In the worst case observed, a one-hour time step (the most common size used in PV performance simulations) resulted in errors of up to 50% in the calculation of utility-interactive energy flows. Such variations can occur when highly variable insolation conditions and/or loads occur on an intra-hour basis. For the purposes of projecting PV system performance under some typical set of conditions, hourly performance estimates appear adequate. However, in detailed design and cost analysis for a particular application, shorter time intervals would better represent variations over time when the data are available and where highly variable insolation and/or load conditions are envisioned.

The majority of models assume that the diffuse component of solar radiation is isotropic (uniformly distributed over the sky dome). The E&R and LCP models have done some preliminary work to examine the more general anisotropic case using the Klucher (1979) model. Initial results using the E&R model indicate that differences of as much as 4.5 to 7.5% additional energy in tracking systems and 4 to 6% additional energy for fixed array systems may occur using the anisotropic assumption (Borden and Reiter, 1983). The largest variations occur in the higher-latitude locations for tracking, flat-plate arrays. However, in the lower latitudes of the desert southwest U.S., smaller differences on the order of approximately 4% were determined for fixed flat-plate arrays.

The models that have examined cell/module failure have typically modeled the open-circuit type. The E&R model has been extended to model short-circuit or hot-spot heating failures (Gonzalez and Weaver, 1980).

Another area of interest has been the modeling of the solar spectrum multiplied by the spectral response of the PV cell studied. Such studies are useful for comparing different PV materials and cell designs; however, at the system level, initial studies conclude that this effect is small (Bush, 1983). On the other hand, other work has shown rather dramatic shifts in the spectrum under polluted and hazy conditions (Gammon, et al., 1981; Huning and Smith, 1981; Smith, et al., 1980). This is still an open issue in some contexts, for instance, comparison of performance for different cell materials. Only the E&R model has the capability for examining the spectral distribution, PV spectral response, and the resulting impact on system power output.

2. Open Topics

A number of open issues were identified during the course of this study. In particular, a concern that seems to overshadow the problem of additional model development is the improvement in the quality of data input. Concerns have been raised about calibration of insolation instruments, measurements, and therefore, model inputs; the uniformity of cell and module measurements to calibrate the models; and the host of other parameters typically used to specify the model. Obviously, errors and uncertainties in these inputs are carried through to the results. In a sense, the variety of model detail presented in this study illustrates that the usefulness of these models also depends on the quality of input data available. The model user must have confidence in the inputs before deciding to run the model. If such confidence is not warranted, a simpler, more easily used model might suffice

with equally useful results. This is an ongoing issue in all model development. Given the variety of models available, there is certainly a choice for the user in terms of input specification versus model complexity.

There is an issue of insolation variability and its effect on PV performance. It would be useful to have better information in the right form, frequency, and quality for performing the studies necessary to gain insight into the effects of such variations on short- and long-term performance.

In the case of utility-interactive systems, the issue of power quality is also of interest (e.g., leading and lagging power factors and harmonic distortion). For the most part, present models generate a static point-in-time estimate of power or energy that does not portray the effects of rapid variations over time. Some of the MIT work (Hart, 1982) has looked at the time-step frequency aspects of power output versus load, but studies of power quality are few. Such studies would, perhaps, assist in the design of better PCU equipment.

Another area that seems to be of interest is an issue of array shadowing effects on performance. When parallel rows of arrays are shaded during the day, parts of the array are not uniformly shadowed, particularly the ends of the array rows. Generally, these end-effects are ignored, and a linear relationship between power output and percentage of module/array shaded is assumed. The effect of partial series string shading is either not judged to be significant or simply has not been examined. We could find no PV performance studies on this issue. This may be one of those situations that is specific to site and PV module and system design. In any event, no generalized shadow model been developed for modeling a variety of array-tracking options and shapes.

One final note that must be considered in weighing the decision to expand model capabilities is the tractability issue. Some of the trade-offs implied by additional complexity or completeness are: more difficulty in specifying accurate inputs; increased computation and cost; and the often decreasing incremental value of the added complexity. Such issues have certainly been weighed by those whose models were examined here. The range of models attests to the varying purposes and requirements of model development and the decisions made during the formulation of the model to capture the phenomena being modeled.

C. SUMMARY OF MODEL GROUPINGS

One of the more difficult tasks of this kind of review is summarizing the models in a concise fashion while capturing the spirit of the model. Three general categories were identified based on the level of model disaggregation into subsystems: (1) simplified PV performance models that can be used for first-order calculations of system performance; (2) detailed PV system performance models that can be used for a variety of systems analyses and that model various subsystems in greater detail than the first category; and (3) special cases that are not system performance models per se but have provided useful results for their individual area of specialty. Table 5-9 uses these categories to illustrate the model groupings.

The first category contains PV F-CHART and PVPM, which are primarily efficiency models that are scaled up to the PV system level. The advantages

Table 5-9. Summary of PV Performance Models

Category	Model	Summary	
Simplified First-Order	PV F-CHART	The model is straightforward (interactive) and provides useful information as a first-order performance and economic calculation based on long-term averages for fixed, flat-plate PV systems.	
	PVPM	A first-order performance calculation based on the product of array area, subsystem efficiencies, temperature-dependent array efficiency, and insolation.	
Detailed PV System Performance ^a Module/Array Flat-Plate	E&R	A set of computer elements linked together to perform detailed system performance studies including effects of mismatch, cell failure, and alternative design strategies.	
	LCP	A system level model for flat-plate array design and performance trade-offs, and system operations over time including performance and cost impacts of mismatch, shading, cell failure and replacement, dirt accumulation and cleaning, and maintenance.	
	TRNSYS/MIT	A detailed thermal and electrical model of a solar array for residential PV systems.	
Cell/Concentrator	SOLCEL-II	A detailed thermal and electrical model of a solar cell extended to the system level by multiplication in insolation, efficiencies, and area to perform design optimization and life-cycle cost studies.	
	SOLSYS	A detailed thermal and electrical performance model of a solar cell extended to the system level by multiplication of insolation, efficiencies, and area.	
	TRNSYS/ASU	A detailed thermal and electrical model of a solar cell extended to the system level by multiplication of insolation, efficiencies (i.e. power conditioning), and area.	
Special Cases	Detailed Electrical	PV-TAP	A detailed, descriptive model of PV electrical networks for the parametric analysis of transient responses in electrical networks and electrical design trade-offs.
	Detailed Reliability		SOLREL

^aSubdivided by technology emphasis although some of the concentrator models can also model flat-plate systems.

of these models are clear. Because of their simplicity, the input requirements are easily collected, and numerous cases can be examined at relatively low cost. However, the variety of design issues that can be examined are limited. This can be seen by examining Tables 5-1 through 5-8. The "N/A" entries ("not addressed/not applicable") point to areas that are not considered. Nevertheless, as a first estimate of system performance for a particular location, these models can be prepared and run with significantly fewer resources than the other models.

Recognizing that it is difficult to define the model categories leads to placing most of the remaining models in the second category. For example, the list can be subdivided into cell models of performance (SOLCEL-II, SOLSYS, TRNSYS/ASU) versus models at higher levels of aggregation, such as module or array level (E&R, LCP, TRNSYS/MIT). For the most part, the cell models were originally developed for modeling PV concentrators while the second group was developed for flat-plate analysis. This distinction is apparent because the thermal aspects of concentrator modeling are more tractable at the cell level. On the other hand, thermal modeling at the module or array level becomes increasingly difficult as the size of the system increases (unless it is assumed that the thermal modeling of a small part of the system will hold for the aggregate). Another distinguishing factor among these two groups is the inclusion of mismatch and cell failure aspects in the flat-plate models (mismatch is implicit in the calibration measurements of the TRNSYS/MIT model), and the exclusion of these aspects in the concentrator models. Examining Tables 5-1 through 5-8 reveals greater emphasis by the flat-plate models on such items as dirt accumulation, module replacements, differences in power conditioning, atmospheric conditions (isotropic vs. anisotropic), and particularly, the aggregation of I-V curves to preserve the electrical characteristics of the system. On the other hand, the cell models tend to scale up the cell performance to the array level by multiplication by area or by numbers of series/parallel elements.

The last category is distinguished primarily by the differing purposes of the models. SOLREL is a reliability analysis model and PV-TAP is a detailed subsystem network model that is aimed at short time-span transient analyses and parametric studies. These models constitute special cases in that they are not aimed specifically at modeling PV system performance. The SOLREL model is an external model that is potentially adaptable to a number of performance models and allows the incorporation of failure analysis. The PV-TAP model is a highly detailed network analysis program that is aimed at parametric analysis of electrical circuits. Tables 5-1 through 5-8 make it clear that the model is extremely versatile for describing the behavior of an electrical system in detail and particularly for examining the transient effects of perturbations on the system over microsecond timesteps.

D. VALIDATION

The purpose of this subsection is to discuss some of the efforts that have been performed to validate the models reviewed here. For the most part, the models examined in this study have been validated by their developers using actual or estimated inputs. These internal validations are the predominant form used. Although some validation is in process, very little work has been done thus far using actual system performance data from operating systems input data collected in parallel. This is especially true for

validation of temperature and insolation effects. For the most part, these internal validations were performed for specific, synthesized systems using SOLMET or TMY input data. The E&R model has been validated against some measured experimental data from PV systems. The LCP model was validated using empirical data from an El Paso, Texas, applications experiment. The PV F-CHART model was validated against extensive simulation runs, using the TRNSYS/ASU program in conjunction with 73 years of hourly simulations (Clark, 1982). PV-TAP has been validated in a selected application within 1.0 to 1.7% of measured results (Lamberski, 1981). The TRNSYS/MIT model uses measured I-V curve pairs and has been validated to within 5% on a 6-minute time scale. For the most part, all models have been checked for reasonableness with outputs from other PV performance models. We do not know if the remaining models have been formally validated.

Some cross validations between models have also been conducted in which common input data sets and assumptions were established and the results compared. As the number of PV performance models has increased, so has interest in cross comparison of such models.

One such study involved the comparison of the LCP, SOLCEL-II, and a model used by Acurex Corporation. The study involved the comparison of design options for a proposed PV plant to be built by the Sacramento Municipal Utility District (Borden, 1982). These options included one-axis horizontal tracking; fixed flat-plate arrays at a variety of tilt and azimuth angles; and two-axis tracking arrays. Differences between models in the unshaded cases ranged from 0.8 to 6.6%. In addition, E&R model results were compared informally, and similar agreement was obtained.

A study is also under way at Sandia National Laboratories to examine numerical comparisons between SOLCEL-II, TRNSYS/ASU, and PV F-CHART (Menicucci, personal communication, 1983). The purpose of this study is to assess the differences between the modeled predictions of PV performance and actual performance; to explain these differences in terms of physical factors such as climatic variation or system configuration; and to recommend improvements to the various models.

These studies are indicators of the importance of cross-comparison of model results. Such studies strengthen the credibility of the modeling approaches used and the understanding of where differences may arise. They also provide a forum for model improvements and the communication of assumptions. It is important to note that these validation studies lend support to the fact that these models are, in fact, doing a good job of estimating PV system performance. Although the purposes of these models are different, they are similar in a general sense and can provide credible projections of PV performance. However, more work needs to be done to validate how these models perform under a controlled environment using system data and environmental data (insolation and temperature) collected in parallel for the same site and system for the same time period.

However, the ultimate test of a model's value is how well it can predict actual and future PV performance rather than how closely it compares with other models. The challenge is to collect and evaluate empirical data to validate or reject model assumptions and approaches, and to identify new areas of PV performance analysis requirements.

SECTION VI

DISCUSSION AND CONCLUSIONS

The review of models included in this study provides a glimpse of the extensive work that has been performed in PV performance modeling. An attempt has been made to give the reader some insight into the purpose(s), applications, approaches, and general usefulness of each of these models.

To this end, the following objectives of the study were performed. The first objective was to develop a representative taxonomy of PV performance model topics and attributes that would characterize the approach and emphasis of each model. These topics (table headings) and attributes (table subheadings) appear in Table 3-1 and Tables 5-1 through 5-8. Each model was reviewed in the context of these characteristics to identify their perspectives and purposes.

The second objective was to identify and review a comprehensive sample of PV performance models that have contributed to photovoltaic research and development and span a range of modeling detail. The list of models and their selection criteria are presented in Section I-C. A detailed review of each model in the context of the attributes and issues is presented in Section III. These reviews were sent to an author or co-author for each model for comments regarding interpretation, new developments, and applications.

The third objective was an attempt at determining the emphasis of each of the models using the attributes derived to group the models according to their perspectives. The models fell into four categories based on their level of disaggregation into subsystems: (1) simplified PV performance models; (2) detailed PV performance models; and (3) special cases.

The first category contains PV F-CHART and PVPM, which are first-order models for estimating system performance. The calculations involve multiplying array efficiency by array area and insolation.

The second category contains the majority of models, but these can be further subdivided. For example, SOLCEL-II, SOLSYS, and TRNSYS/ASU model performance at the cell level (cell I-V curve) and then multiply upward (by area or number of series/parallel elements) to the system level. In addition, they have extensive thermal modeling because they were developed for modeling concentrating systems in addition to flat-plate systems. On the other hand, the E&R, LCP, and TRNSYS/MIT models address flat-plate systems at a higher level such as the module efficiency or array I-V curve level (note the E&R model is not limited to the array level because it models generic I-V curves which can represent cells, modules, or arrays). It is difficult to differentiate the models within this group because each one models subsystems to varying levels of detail. The concentrator models have extensive thermal capabilities and collector models and virtually no operations and maintenance components. On the other hand, the flat-plate models tend to use simpler thermal models and extensive operations and maintenance. The point to be made is that each of these models serves a particular purpose, and the distinctions are a matter of degree.

The third category contains SOLREL and the PV-TAP model because these models are aimed at different purposes. The intent and purpose of these models was not for site-specific or collector-specific studies, but rather, as a tool for analyzing the reliability and availability characteristics of a PV system (SOLREL) and parametric studies of electric networks under transient and steady-state conditions (PV-TAP).

In an attempt to summarize each of the models and capture their uniqueness, a summary statement is provided in Table 5-9.

The fourth objective of this study was to document the variety of approaches implemented by the various models. This document attempts to provide such documentation.

The fifth objective was to identify areas of recent extensions or future research that may have impacts on current knowledge. These extensions include the capability to model Fresnel refraction of the encapsulant material and the modeling of anisotropic diffuse atmospheres (E&R, LCP); and effects of using simulation time steps other than one-hour (TRNSYS/MIT).

There are a number of possible limitations to the present study.

The first issue is one of completeness of the list of issues and attributes. If the methodology applied here were used to evaluate another model not included at the outset, this could be a problematic issue. A key point here is that the issues and attributes were derived from the set of models examined. The comprehensive list of topics and attributes is believed to be substantially complete (the model developers who reviewed the model summaries in Section IV had no comments on the completeness or accuracy of the list). The major objection to the stated attributes and issues was the omission of context (the purpose of the model) from the list. However, the identification and clarification of model emphasis or purpose was an objective of this study, separate from the list in Table 3-1.

A second limitation could be one of generality. It is recognized that other models exist and are being developed. Their inclusion in the study would probably have uncovered additional information. In fact, no models from the PV manufacturing industry were reviewed. However, given the criteria for model selection (degree of usage, usage as a policy tool, usage as a design tool, existence of documentation, and non-proprietary availability), the list selected is believed to at least capture the range of capabilities for what appear to be the more widely known and used models.

A third concern, which is more a problem within the models themselves rather than this study, centers on whether a model has been used for analyses outside its true range of capabilities (re-structuring the problem to fit the model). This type of concern is difficult to evaluate because no attempt at validation was made. Furthermore, it has been recognized that each model, in the context of its purpose, has provided useful results. Cases where the model's application may have been "stretched" beyond its capabilities are difficult to identify and impossible to document. No judgment is made here regarding the unclear boundary between the application of a model's capabilities and the problem to which it is applied. This Type III error or probability of solving the wrong problem exactly (Mitroff, 1974) is beyond the

scope of this study. This report does, however, re-state model purposes so that the reader can judge model applicability to a given set of problems.

For the set of models reviewed in this study, the following conclusions have been drawn from this study:

- (1) There are a wide variety of PV performance models that have provided and continue to provide useful contributions to photovoltaic research and development (see Table 5-9).
- (2) Each model was developed with a purpose in mind. The purpose of the model is important because the use of these models outside the range of their intended application could lead to questionable results.
- (3) Because of varying purposes, the models address PV performance issues characterized at different levels of detail (complexity). Furthermore, simplicity does not imply that a model is relatively less useful.
- (4) Many of the above models have been validated for specific applications, and there are some baselines of agreement among models.
- (5) A major problem is the need for better quality input data, which outweighs the need for developing new models although refinements could be made to existing models as more data and PV alternatives become available. The SOLREL model is an example of a refinement.
- (6) A number of recent extensions to specific models have been incorporated or examined, including:
 - (a) Fresnel refraction by encapsulant material (E&R, LCP).
 - (b) Effects of using simulation time scales other than one hour (TRNSYS/MIT).
 - (c) Modeling of anisotropic atmosphere for diffuse solar radiation component (E&R and LCP).
 - (d) Effects of insolation spectral distribution on power output (E&R).
- (7) There are a number of areas that appear to be open modeling questions that have not been covered well by the models reviewed:
 - (a) The effects of insolation variability on PV system performance. Specifically, the kinds of data that are necessary for such studies in terms of timestep, form, and quality need to be identified.
 - (b) Modeling quality of PV power output versus utility grid interconnect requirements.

- (c) Effects of partial shading of arrays on performance (linear assumption of 10% shading = 10% power loss and end effects). A related problem is the estimation of shadow losses for different collector options and shapes.

SECTION VII

REFERENCES

- Anderson, E., T. Lambariski, D. Kadlec, J. Nakos, and R. Turfler, Analysis of the MT. Laguna P/V Cell Failure, Report BDM/A-80-027-TR-R2, The BDM Corporation, Albuquerque, NM, December 1980.
- Boes, E. C., et al., Distribution of Direct and Total Solar Radiation Availabilities for the U.S.A., Sandia Report SAND76-0411, August 1976.
- Borden, C. S., Lifetime Cost and Performance Model For Distributed Photovoltaic Systems, Volume 1: Summary, JPL Document 5220-12, Jet Propulsion Laboratory, Pasadena, California, August 1981.
- Borden, C., Photovoltaic System Design Assessment Summary Results, SMUD Technical Assistance Team, JPL Document 5250-16, Jet Propulsion Laboratory, Pasadena, California, August 1982.
- Borden, C. S., and L. Reiter, "Comparison of Fixed vs. Tracking Flat-Plate PV Arrays Under Isotropic and Anisotropic Diffuse Radiation Assumptions," JPL IOM #311.3-668/0975E, Jet Propulsion Laboratory, Pasadena, CA, June 27, 1983.
- Borden, C. S., The Value of Residential Photovoltaic Systems: A Comprehensive Assessment, JPL Publication 83-63, Jet Propulsion Laboratory, Pasadena, CA, September 1983.
- Bray, R. E., Solar-Climatic Statistical Study, Vols. 1 and 2, HCP/T-4016/1,2, Northrup Services, Huntsville, Alabama, February 1979.
- Bugler, J. W., "The Determination of Hourly Insolation on an Inclined Plane Using a Diffuse Irradiance Model Based on Hourly Measured Global Horizontal Insolation," Solar Energy, Vol. 19, No. 5, 1977, pp. 477-492.
- Bush, L. R., Photovoltaic Energy Systems Summary Report, ATR-83 (3828-02)-IND, The Aerospace Corp., El Segundo, CA, June 1983.
- Clark, D. R., Hourly Radiation Utilizability and Its Application to Photovoltaic Systems, M.S. Thesis, Mechanical Engineering, University of Wisconsin-Madison, 1982.
- Clark, D. R., S. A. Klein, and W. A. Beckman, "A Method For Estimating The Performance of Photovoltaic Systems," (in publication--submitted to Solar Energy), Solar Energy Laboratory, University of Wisconsin, Madison, Wisconsin, 1983.
- Collaros, G. J., T. J. Lambariski, W. E. Schwinkendorf, P. Soma, C. A. Irby, and W. M. Resnik, Module Optimization Methodology for Advanced PV Cells and Devices, Final Report, BDM Contract XG-1-1064-1, The BDM Corporation, Albuquerque, NM, July 1982.

Davisson, M. C., C. S. Borden, L. J. Reiter, and J. H. Smith, Lifetime Cost and Performance Model: Microcomputer Version User's Guide and Documentation, JPL Internal Document D-944, Jet Propulsion Laboratory, Pasadena, CA, August 1983.

De Blasio, SERI, personal communication with J. H. Smith, Golden CO, January 18, 1983.

Doane, J. W., R. P. O'Toole, et al., The Cost of Energy from Utility-Owned Solar Electric Systems, ERDA/JPL-1012-76/3, June 1976.

Duffie, J. A., and W. A. Beckman, Solar Engineering of Thermal Processes, Wiley-Interscience, New York, 1980.

Edenburn, M. W., Analytical Models for Solar Photovoltaic Energy System Components, SAND80-2557 Albuquerque: Sandia National Laboratories, April 1981.

Erbs, D. G., S. A. Klein, and J. A. Duffie, "Estimation of the Diffuse Radiation Fraction for Hourly, Daily, and Monthly-Average Global Radiation," Solar Energy Vol. 28, No. 4, pp. 293-302, 1982.

Evans, D. L., W. A. Facinelli, and R.T. Otterbein, Combined Photovoltaic/Thermal System Studies, SAND78-7031, Sandia Laboratories, Albuquerque, NM, August 1978.

Evans, D. L., W. A. Facinelli, and L.P. Koehler, Simulation and Simplified Design Studies of Photovoltaic Systems, SAND80-7013, Sandia Laboratories, Albuquerque, NM, September 1980.

Facinelli, W. A., "Modeling and Simulation of Lead-Acid Batteries for PV Systems," Proceedings of 18th IEEE Photovoltaic Specialists Conference, Orlando, FL., 1983.

Florschuetz, L. W., "Extension of the Hottel-Whillier-Bliss Model to the Analysis of Combined Photovoltaic/Thermal Flat-Plate Collectors," Sharing the Sun Joint Conference, U.S. and Canadian Sections of International Solar Energy Society, Vol. 6, p. 79, Winnipeg, 1976.

Gammon, R., J. Huning, and M. S. Reid, "Urban Air Pollution and Solar Energy," International Journal of Ambient Energy, Vol. 2, No. 4, pp. 183-195, October 1981.

Goldstein, L. H. and G. R. Case, PVSS-A Photovoltaic System Simulation Program User's Manual, SAND77-0814 Albuquerque: Sandia National Laboratories, June 1977.

Gonzalez, C. and R. Weaver, "Circuit Design Considerations for Photovoltaic Modules and Systems," presented at 14th IEEE Photovoltaic Specialist Conference, San Diego, CA, January 7-10, 1980.

Gonzalez, C., G. Hill, and R. Ross, "Characterization of the Electrical Output of Flat-Plate Photovoltaic Arrays," Proceedings of the 16th IEEE Photovoltaic Specialists Conference, San Diego, CA, September 1982a.

_____, Photovoltaic Array-Power Conditioner Interface Characteristics, DOE/JPL-1012-79, Jet Propulsion Laboratory, Pasadena, CA, December 15, 1982b.

Gonzalez, C., personal communication, March 25, 1983.

Gonzalez, C. and R. Ross, "Energy Prediction Using NOCT Based Photovoltaic Reference Conditions," Proceedings of the 1983 Annual Meeting of ASES, Minneapolis, MI, pp. 935-940, 1983.

Gonzalez, C., and R. Weaver, "Circuit Design Considerations for Photovoltaic Power Systems," 14th IEEE Photovoltaic Specialists Conference, CH 1508-1/80/000-0258, San Diego, CA, January 7-10, 1980, pp. 528-535.

Grundstrom, S., personal communication, SERI, Golden CO, September 7, 1983.

Hall, I., R. Prairie, H. Anderson, and E. Boes, Generation of Typical Meteorological Years for 26 SOLMET Stations, SAND78-1601, Sandia Laboratories, Albuquerque, NM, August 1978.

Hanson, K. J. and J. J. DeLuisi (1981), "Forecasting Solar Energy on Synoptic and Longer Time Scales with Mean Values and Persistence Methods," from Satellites and Forecasting of Solar Radiation, Proceedings of First Workshop on Terrestrial Solar Resource Forecasting and on the Use of Satellites for Terrestrial Solar Resource Assessment, Washington, D.C., February 2-5, 1981.

Hart, G. W., and P. Raghuraman, "Residential Photovoltaic System Simulation: Thermal Aspects," presented at ASME Solar Energy Division Fourth Annual Technical Conference, Albuquerque, NM, April 26-30, 1982a.

_____, Electrical Aspects of Photovoltaic System Simulation, DOE/ET/20279-207, Massachusetts Institute of Technology Lincoln Laboratory, Lexington, Massachusetts, June 1982b.

_____, Simulation of Thermal Aspects of Residential Photovoltaic Systems, DOE/ET/20279-202, Massachusetts Institute of Technology Lincoln Laboratory, Lexington, Massachusetts, June 1982.

Hart, G. W., "Residential Photovoltaic System Simulation: Electrical Aspects," 0160-8371/82, presented at 16th IEEE Photovoltaic Specialists Conference, San Diego, CA, September 27-30, 1982.

_____, The Effect of Data Sampling Rate on Utility Interaction Calculations, DOE/ET/20279-212, Massachusetts Institute of Technology, Lincoln Laboratory, Lexington, MA, October 1982.

Hoover, E. R., "SOLCEL-II: An Improved Photovoltaic System Computer Program," Proceedings of 14th annual Photovoltaic Specialists Conference, CH-1508-1/80/0000-1258, pp. 1258-1261, San Diego, CA, January 7-10, 1980a.

_____, SOLCEL - II: An Improved Photovoltaic System Analysis Program, SAND79-1785 Albuquerque: Sandia National Laboratories, February 1980b.

Huning, J., and J. H. Smith, "Air Pollution: A Geographic Constraint to Siting of Solar Energy Options," Energy in the Man-Built Environment: The Next Decade, Urban Planning and Development Division, American Society of Civil Engineers, Vail, CO, August 1981.

Huss, W. R., "Evaluating the Reliability and Availability of Photovoltaic Systems," Simulation, Vol. 40, No. 4, pp. 133-145, April 1983.

Hyman, E. A., Phenomenological Cell Modeling: a Tool for Planning and Analyzing Battery Testing at the BEST Facility, Report RD77-1, Public Service Electric and Gas Company and PSE & G Research Corporation, Newark, NJ, 1977.

JPL, Flat-Plate Photovoltaic Module and Array Circuit Design Optimization Workshop Proceedings, JPL Document 5101-170, Jet Propulsion Laboratory, Pasadena, CA, May 19-20, 1980.

Klein, S. A., et al., TRNSYS--A Transient System Simulation User's Manual, University of Wisconsin-Madison, Engineering Experiment Station Report 38-10, 1979.

Klein, S. A. and W. A. Beckman, PV F-CHART User's Manual: Microcomputer Version, F-Chart Software, Middleton, Wisconsin, January 1983.

Klucher, T. M., "Evaluation of Models to Predict Insolation on Tilted Surfaces," Solar Energy, Vol. 23, pp. 111-114, 1979.

Lamberski, T. J., A. F. Malmberg, K. E. Melick, R. M. Turfler, and M. G. Semmens, Photovoltaic Transient Analysis Program User's Guide, Volume 2, Guide to Photovoltaic Elements, SAND78-7038-Vol. 2 Albuquerque: Sandia National Laboratories, October 1978.

Lamberski, T. J., A. F. Malmberg, K. E. Melick, R. M. Turfler, and M.G. Semmens, Photovoltaic Transient Analysis Program User's Guide, Volume 3, PV-TAP/NET-2 User's Manual, SAND78-7038 Albuquerque: Sandia National Laboratories, August 1979.

Lamberski, T. J., and G. J. Collaros, "PV-TAP - Its Use and Capabilities," presented at Photovoltaic System Definition and Development Project Integration Meeting, Sandia Laboratories, Albuquerque, NM, October 12-13, 1980.

Lamberski, T. J., J. A. Higbie, and C. B. Rogers, "A Technique for Comparing Parabolic Trough Photovoltaic Performance," Proceedings of the 15th IEEE Photovoltaic Specialists Conference, 81CH1644-4, Kissimmee, FL, May 12-15, 1981a, pp. 183-186, 1981.

Lamberski, T. J., D. L. Kadlec, and C. B. Rogers, "Effects of Cell Sorting and Module Matching on Array Output," Proceedings of 15th IEEE Photovoltaic Specialists Conference, 81CH1644-4, Kissimmee, FL, May 12-15, pp. 841-844, 1981.

Lamberski, T. J., The BDM Corporation, Albuquerque, NM, personal communication with J. H. Smith, October 3, 1983.

Latta, A. F., J. M. Bomyer, T. Fujita, and P. H. Richter, The Effects of Regional Insolation Differences Upon Advanced Solar Thermal Electric Power Plant Performance and Energy Costs, JPL Document 1060-17, Jet Propulsion Laboratory, Pasadena, CA, March 1979.

Leonard, S. L., E. J. Rattin, and B. Siegal, Mission Analysis of Photovoltaic Solar Energy Conversion, Vols. 1-4, ATR-77(7574-07)-1, Aerospace Corporation, El Segundo, California, March 1977.

Leonard, S. L., and E. Simberger, Aerospace Corporation, El Segundo, California, personal communication with J. H. Smith, April 1983.

Levy, S. L. and L. E. Stoddard, Integrated Photovoltaic Central Station Conceptual Design, Black and Veatch Research Project RP2197-1, July 1983.

Linn, J. K., SOLCEL--Photovoltaic System Analysis Program, Report No. SAND77-1268, Sandia Laboratories Albuquerque, NM, 1977.

Liu, B.Y.H. and R. C. Jordan, "The Interrelationship and Characteristic Distribution of Direct, Diffuse, and Total Solar Radiation," Solar Energy, Vol. 4, No. 3, pp. 1-19, July 1960.

Luft, W., J. R. Barton, and A. A. Conn, "Multifaceted Solar Array Performance Determination," TRW Systems Group, Redondo Beach, CA, February 1967.

Malmberg, A. F., "User's Manual, NET-2 Network Analysis Program," Braddock, Dunn, and McDonald, Inc., El Paso, Texas, September 19, 1972.

Menicucci, D. F., Div. 6221, Sandia National Laboratories, Albuquerque, NM, personal communication with J. H. Smith, December 7, 1983.

Mitroff, I. I., "On Systemic Problem Solving and The Error of The Third Kind," Behavioral Science Vol. 19, pp. 383-393, 1974.

Otterbein, R. T., D. L. Evans, and W. A. Facinelli, "A Modified Single Diode Model for High Illumination on Solar Cells for Simulation Work," Proceedings of the 13th IEEE Photovoltaic Specialists Conference, Washington, D.C., June 5-8, 1978.

Otterbein, R. T. and D. L. Evans, "Two Modified Single Diode Models for Simulating Solar Cells with Distributed Series Resistance," Proceedings of the 14th IEEE Photovoltaic Specialists Conference, San Diego, CA, January 7-10, 1980.

Perino, A. M., A Methodology for Determining the Economic Feasibility of Residential or Commercial Solar Energy Systems, Report No. SAND78-0931, Sandia Laboratories, Albuquerque, NM, 1978.

Randall, C. M. and J. M. Biddle, Hourly Estimates of Direct Insolation: Computer Code ADIPA User's Guide, The Aerospace Corporation, AIR-81 (7878)-1, September 1981.

Randall, C. M., B. R. Johnson, and M. E. Whitson, Measurements of Typical Insolation Variation at Daggett, California, Vols. 1 and 2, Aerospace Report No. ATR-80(7747)-1, Vols. 1,2, The Aerospace Corporation, El Segundo, California, 1 March 1980.

Ross, R. G., Jr., "Photovoltaic Design Optimization for Terrestrial Applications," Proceedings of the 13th IEEE Photovoltaic Specialists Conference, Washington, D.C., pp. 1067-1073, June 5-8, 1978.

Ross, R. G., Jr., "Flat-plate Photovoltaic Array Design Optimization," presented at 14th IEEE Photovoltaic Specialists Conference, CH 1508-1/80/000-1126, pp. 1126-1132, San Diego, CA, January 7-10, 1980a.

Ross, R. G., and C. C. Gonzalez, "Reference Conditions for Reporting Terrestrial Photovoltaic Performance," Proceedings of the 1980 Annual Meeting of AS/ISES, Phoenix, AZ, pp. 1091-1097, 1980b.

Ross, R. G., Jr., "Terrestrial Photovoltaic Performance Reference Conditions," Proceedings of 3rd E.C. Photovoltaic Solar Energy Conference, pp. 731- 725, October 1980c.

Shepherd, C. M., "Design of Primary and Secondary Cells II. An Equation Describing Battery Discharge," Journal of The Electrochemical Society, Vol. 112, p.657, 1965.

Siegel, M. D., S. A. Klein, and W.A. Beckman, "A Simplified Method for Estimating the Monthly-Average Performance of Photovoltaic Systems," Solar Energy, Vol. 26, pp. 413-418, 1981.

Smith, J. H., J. R. Huning, M. S. Reid, and R. B. Gammon, "Urban Air Pollution: Its Effect on the Design and Performance of Solar Energy Systems," Proceedings of the 3rd Miami International Conference on Alternative Energy Sources, Miami, Florida, December 1980, pp. 27-46, published in Alternative Energy Sources III, Hemisphere Publishing Corp., Washington, 1983.

Solar Cell Array Design Handbook, Volume 1, 9.2, (Jet Propulsion Laboratory), reproduced by National Technical Information Service, U.S. Dept. of Commerce, Springfield, VA, #N77-14193, 1976.

Solar Energy Research Institute, Solar Models: Data Base Candidates, SERI/SP-451-563, Solar Energy Research Institute, Golden, CO, January 1980.

Stember, L. H., W. R. Huss, and M. S. Bridgman, Battelle Columbus Laboratories, Reliability-Economics Analysis Models for Photovoltaic Power Systems, Volumes 1 and 2, Contractor Report SAND82-7126/1&2 Albuquerque: Sandia National Laboratories, November 1982.

Taylor, R., EPRI, Palo Alto, CA, personal communication with L. Reiter, 1983.

Warren, A. W., R. W. Edsinger, and J. D. Burroughs, SIMWEST: A Simulation Model for Wind and Photovoltaic Energy Storage Systems (CDC User's Manual) Volume 1, Boeing Computer Services, Inc., DOE/NASA/0042-79/3, NASA CR 159607, BCS 40262-1, Prepared for Lewis Research Center, August 1979.

APPENDIX

OBTAINING THE MODELS

Listed below is information to help interested readers obtain copies of the models and their documentation. Most of the models are available upon request although, in some cases, a fee is required.

- E&R: This model is not supported for dissemination. Reference documents are available from the National Technical Information Service (NTIS) at 703-487-4650.
- LCP: Contact NTIS (703-487-4650) for the documentation. A diskette with the program can be obtained by contacting Leonard Reiter at the Jet Propulsion Laboratory, (213-577-9183) Mail Stop 506-316, 4800 Oak Grove Drive, Pasadena, CA 91109.
- PVPM: The documentation for this model is forthcoming from the Electric Power Research Institute (EPRI).
- PV F-CHART: Write or call F-CHART Software, Inc. for diskettes with the program and for documentaiton at 608-836-8536, 4406 Fox Bluff Rd., Middleton, WI 53562.
- PV-TAP: The documentation (SAND 78-7038-Vol. 1-3) is available through NTIS (703-487-4650). Contact Dr. E. L. Burgess at Sandia National Laboratories for the code. Call 505-844-2178 or write to Division 6221, Sandia National Laboratories, P.O. Box 5800, Albuquerque, NM 87185.
- SOLCEL-II: The documentation (SAND 77-1268) is available from NTIS (703-487-4650) and the code may be obtained from the National Energy Software Center (NESC) Argonne National Laboratory, 9700 South Cass Ave., Argonne, Illinois 60439.
- SOLREL: The documentation (SAND 82-7152) is available from NTIS (703-487-4650) and the code may be obtained by writing Division 6223, Sandia National Laboratories, P.O. Box 5800, Albuquerque, NM 87185.
- SOLSYS: This model is not supported for dissemination. The documentation (SAND 80-2557) is available from NTIS (703-487-4650).
- TRNSYS/ASU: Versions 11.0 or later of this program from the University of Wisconsin contain this code. Write 1500 Johnson Drive, University of Wisconsin-Madison, Madison, WI 58706. For the temperature and wear dependent battery model call Dr. Don Evans at Arizona State University (602-965-2191).
- TRNSYS/MIT: Contact George Hart at the MIT Energy Laboratory (617-863-5500 ext. 812243) for information concerning the code and documentation.