

# LEGIBILITY NOTICE

A major purpose of the Technical Information Center is to provide the broadest dissemination possible of information contained in DOE's Research and Development Reports to business, industry, the academic community, and federal, state and local governments.

Although a small portion of this report is not reproducible, it is being made available to expedite the availability of information on the research discussed herein.

NUREG/CR-4740

TI88 007920

# NUCLEAR PLANT-AGING RESEARCH ON REACTOR PROTECTION SYSTEMS

Leroy C. Meyer

Published January 1988

EG&G Idaho, Inc.  
Idaho Falls, Idaho 83415

Prepared for the  
Division of Engineering  
Office of Nuclear Regulatory Research  
U.S. Nuclear Regulatory Commission  
Washington, D.C. 20555  
Under DOE Contract No. DE-AC07-76ID01570  
FIN No. A6389  
NRC Program Manager  
J. P. Vora

**MASTER**

DISTRIBUTION OF THIS DOCUMENT IS UNLIMITED

## **ABSTRACT**

This report presents the results of a review of the Reactor Trip System (RTS) and the Engineered Safety Feature Actuating System (ESFAS) operating experiences reported in Licensee Event Reports (LERs), the Nuclear Power Experience data base, Nuclear Plant Reliability Data System, and plant maintenance records. Our purpose is to evaluate the potential significance of aging, including cycling, trips, and testing as contributors to degradation of the RTS and ESFAS. Tables are presented that show the percentage of events for RTS and ESFAS classified by cause, components, and subcomponents for each of the Nuclear Steam Supply System vendors. A representative Babcock and Wilcox plant was selected for detailed study. The U.S. Nuclear Regulatory Commission's Nuclear Plant Aging Research guidelines were followed in performing the detailed study that identified materials susceptible to aging, stressors, environmental factors, and failure modes for the RTS and ESFAS as generic instrumentation and control systems. Functional indicators of degradation are listed, testing requirements evaluated, and regulatory issues discussed.

## EXECUTIVE SUMMARY

Operating experiences of nuclear power plants were evaluated to determine the significance of service wear on equipment due to aging (including testing, cycling, and trips) and the possible impact of service wear on safety. Generic instrumentation and control channels of the Reactor Trip System (RTS) and Engineered Safety Feature Actuating System (ESFAS), which together make up the Reactor Protection System (RPS) were selected for detail study. This work is part of the U.S. Nuclear Regulatory Commission's (USNRC's) Nuclear Plant Aging Research (NPAR) Program and follows the NPAR guidelines.

The NPAR guidelines provided the framework through which the effect of aging on RPS was studied. The products asked for in the NPAR guidelines include:

1. Preliminary identification of susceptibility of materials to aging
2. Stressors and related environmental factors causing aging degradation
3. Failure modes experienced during operation and their causes
4. Functional performance indicators
5. Current inspection, surveillance, and monitoring methods
6. Current maintenance practices.

Data sources used include Licensee Event Reports (LERs), the Nuclear Power Experience (NPE) data base, Nuclear Plant Reliability Data System (NPRDS), and material from an operating nuclear plant supplied by a utility (including personnel interviews).

The LER review covered 6 years of data from the Idaho National Engineering Laboratory (INEL)-developed instrumentation and control (I&C) LER data base. Events were classified by time in service (age) and frequency of use (demand). About 25% of the events were demand-related. A portion of the demand-related events can be attributed to testing, cycling, and trips. The demand-related events here are those reported in the LER.

The NPE data-base events covered approximately a 25-year period and included LERs as well as other information available in the public domain. The data from NPE were grouped by the Nuclear Steam Supply System (NSSS) vendor. In this way, there are enough events to be representa-

tive; the number of failures as reported per plant were too few to be statistically significant.

The NPRDS data were limited to the Westinghouse and General Electric plants for which RTS data were available. The aging fraction (ratio of aging-related failures to total number of failures) was determined for the various RTS components.

Results from the NPE review of the RTS indicate that components associated with pressure measurements experience the highest number of failure events for all NSSS vendors, except General Electric (GE). Measurements using level transducers had the most failure events for GE, with pressure second. At the sub-component level, the five categories with the highest number of system events were: sensors and transmitters, electronic parts, bistables, breakers, and power supplies. About 55% of the sensor and transmitter events were due to drift. Total sensor failure was only 2.7% of the events. Operator and maintenance error top the list for causes followed by I&C component failure, design errors, mechanical wear, and drift. Approximately 49.3% of the events for RTS were potentially aging related. Potentially aging related means that aging could be a contributing cause, but actual root cause was not always determined in the data base.

Data from the NPE and LER data bases provided information on components that were involved most frequently in RTS and ESFAS faults, as well as a summary of causes for the events. However, these data bases seldom provide actual measured values of analog parameters which are needed to establish trends relating to component degradation or aging studies.

Generic channels selected for detailed study included the input instrumentation channels, with associated analog and logic components, that are part of the RTS and ESFAS for a representative Babcock and Wilcox (B&W) plant. One-line diagrams are presented for each channel along with engineering data related to aging for each of the major components. Materials subject to aging are identified for the major RPS components located in containment.

While this report primarily covers the actuating part of the RTS, scram breakers are included in the data summary tables. A discussion of scram breakers is included in appendix B.

Actual plant records evaluated included drawings, operating and maintenance (O&M) manuals, and O&M records. The greater detail available from plant

records is helpful in aging studies. For example, the plant corrective maintenance (CM) summary records listed about 31 work requests for the RPS over a 4-1/2-year period. The LERS had nine events and NPE had seven events for the same 4-1/2-year period. The NPRDS listed eight failures from February 10, 1982, to April 25, 1985, and CM had twenty-two items for this same period. See Appendix A for a detailed evaluation of the data sources.

One of the objectives in this study was to identify functional indicators of degradation that may occur during plant life. However, events from the data sources are essentially point sources and additional information is needed to establish trends. Once trends are established, indicators of degradation can then be observed from changes in continuous or periodic measurements. On-site test and calibration records include analog values, as-found and as-left, which may be used for limited trend studies.

Essential auxiliary systems for the RPS are the Class 1E power system and the heating-ventilating-air conditioning system. The loss of electrical power would trip the channel. The effect of loss of air-conditioning is uncertain and depends on many factors, including system design.

Regulatory issues related to RPS are discussed, which include design requirements, life extension, equipment qualification, cables, and testing requirements.

Testing requirements in the standard technical specification, regulatory guides, and Institute of

Electrical and Electronic Engineers (IEEE) standards were reviewed to determine whether functional indicators are adequately monitored. It was found that current testing requirements do not demand condition-monitoring-type data be collected, other than verifying setpoint values and actuating-response times. Condition-monitoring data is defined as measured parameter values that could be used for trend analysis.

Four aspects of the current testing requirements are of concern in assessing the adequacy of the program. These are: testing frequency, type of data collected, testing relationship to preventive maintenance, and response-time testing.

A significant number of trips are due to testing, as compared to actual trips required in performing safety functions. This results in cyclic aging. However, the amount of wear is difficult to quantify and the effects on plant operation are minimal due to redundancy of channels. Usually, only one channel is inoperable when a fault occurs. The effect on plant operation is that the trip logic will then be put into a 1-out-of-3 mode instead of the 2-out-of-4 normal operation mode. Thus, the faulty channel is bypassed until repairs are completed. Where preventive maintenance is practiced, the potential safety significance of mechanical component wear is further reduced. A good maintenance program, when implemented (coordinated with testing) almost makes aging a nonproblem on redundant systems such as RPS, because the periodic rejuvenation does not allow the system to grow old.

## **ACKNOWLEDGMENTS**

The detailed systems studies are based on material supplied by the Duke Power Company, Charlotte, North Carolina.

# CONTENTS

ABSTRACT .....	ii
EXECUTIVE SUMMARY .....	iii
ACKNOWLEDGMENTS .....	v
LIST OF ACRONYMS .....	xi
INTRODUCTION .....	1
OBJECTIVES .....	3
REVIEW OF OPERATING EXPERIENCE .....	4
LER Data Base .....	4
Conclusions from Review of LER Data Base .....	4
NPE Data for RTS and ESFAS Generic Study .....	5
NPE Data System Description .....	5
Use of NPE for the RTS/ESFAS Study .....	6
Reactor Trip Systems .....	6
Conclusions from NPE Reactor Trip System Study .....	9
Engineered Safety Features Actuating System (ESFAS) .....	9
Conclusions from NPE ESFAS Data .....	9
Nuclear Plant Reliability Data System (NPRDS) .....	9
Plant Operating Experience from Site Visits and Personnel Interviews .....	13
Conclusions from Site Visits .....	14
REACTOR PROTECTION SYSTEM DETAILED STUDY .....	15
Sensors, Cables, and Penetrations for RTS/ESFAS .....	15
Pressure Measurement .....	15
Pressure Switch .....	17
Flow Measurement .....	17
Temperature Measurement .....	17
Contact Monitor .....	19
Nuclear Instrumentation .....	19
Sensor Tests and Calibrations .....	20
Cable .....	20
Reactor Building Penetrations .....	20
Piping Penetrations .....	20
Instrument Cable Penetrations .....	20
Summary and Conclusions for Sensors, Cables, and Penetrations Review .....	23

B&W Plant Reactor Trip System (RTS) Description .....	24
Shutdown Bypass .....	27
Reactor Coolant Pressure Measurement Channel .....	27
Reactor Coolant Temperature .....	27
Power-Range Channel .....	27
Reactor Coolant Flow Channel .....	34
System Testing .....	34
RPS Periodic Testing Required by NUREG-0103 Rev. 4 .....	39
Summary and Conclusions from RTS Detailed Study .....	39
ESFAS Description for a B&W Plant .....	40
Instrumentation .....	40
System Operation .....	43
Periodic Testing .....	50
Summary and Conclusions for the ESFAS Detailed Study .....	51
Essential Auxiliary Systems and Interfaces .....	51
REGULATORY ISSUES RELATING TO RPS .....	53
Design Requirements and Guidelines .....	53
Issues Related to Design .....	53
Equipment Qualification Requirements .....	53
Maintenance Requirements .....	53
Testing Requirements for Monitoring Functional Indicators .....	57
Adequacy/Inadequacy of the Current RPS Testing Program .....	58
Conclusions About Current Testing Program .....	59
Cables in Containment .....	59
Life Extension .....	60
Conclusions from Review of Regulatory Issues .....	60
NPAR PRODUCTS FOR THE RPS .....	61
Product Number 1—Preliminary Identification of Susceptibility of Materials to Aging .....	61
Product Number 2—Stressors and Related Environmental Factors Causing Aging Degradation .....	61
Product Number 3—Failure Modes Experienced During Operation and Their Causes .....	63
Product Number 4—Functional Performance Indicators .....	63
Product Number 5—Current Inspection, Surveillance, and Monitoring Methods .....	67
Product Number 6—Current Maintenance Practices .....	67

Plant Maintenance Activities .....	67
Regulatory Approach to Plant Maintenance .....	67
CONCLUSIONS .....	68
REFERENCES .....	73
BIBLIOGRAPHY .....	75
APPENDIX A—AN EVALUATION OF INFORMATION SOURCES FOR AGING RESEARCH ON REACTOR PROTECTION SYSTEMS .....	A-1
APPENDIX B—ACTUATED PART OF RTS (Scram Breakers and Associated Circuitry) .....	B-1
APPENDIX C—RELAY PROBLEMS IN THE RPS .....	C-1

## FIGURES

1. Simplified diagram showing boundary for generic RPS aging study .....	2
2. Nonnuclear sensors for RTS/ESFAS .....	16
3. Flow-transmitter piping .....	19
4. Typical instrumentation penetration .....	22
5. Typical reactor building penetration cables for instrumentation .....	24
6. RPS trip string for one channel .....	25
7. Reactor trip module .....	26
8. RPS reactor coolant pressure transmitter piping diagram .....	28
9. RPS reactor coolant pressure channel with supporting aging and engineering data .....	29
10. Reactor coolant temperature and pressure logic .....	30
11. RPS reactor coolant temperature channel with supporting aging and engineering data .....	32
12. RPS power-range channel with supporting aging and engineering data .....	33
13. RPS pump power-monitor channel with supporting aging and engineering data .....	35
14. RPS reactor coolant flow channel with supporting aging and engineering data .....	36

15.	RPS reactor building pressure-switch channel with supporting aging and engineering data .....	37
16.	RPS main feedwater pump and turbine trip block diagram with supporting aging and engineering data .....	38
17.	Engineered safeguards system .....	41
18.	Analog subsystem .....	44
19.	Logic subsystem .....	45
20.	Symbols used in Figures 18 and 19 .....	46
21.	ESPS channel for initiating the HPI with related aging and engineering data .....	47
22.	ESPS channel for initiating the RB cooling and isolation with related aging and engineering data .....	48
23.	ESPS channel for initiating RB spray with related aging and engineering data .....	49

## TABLES

1.	Average number of RTS faults per plant-year by NSSS vendor .....	4
2.	LER event cause ranking for RTS events .....	5
3.	Percent demand-related faults for each NSSS vendor .....	5
4.	RTS component summary .....	7
5.	RTS subcomponent summary .....	8
6.	RTS event cause summary .....	8
7.	ESFAS component summary .....	10
8.	ESFAS subcomponent summary .....	11
9.	ESFAS event cause summary .....	12
10.	Aging fractions from operational data on reactor trip system .....	13
11.	Plant corrective maintenance data events for RPS .....	14
12.	Materials in strain gauge pressure transducers .....	17
13.	Materials in capacitance-type pressure transducers .....	18

14. Resistance temperature detector (RTD) (materials) .....	19
15. Cable materials .....	21
16. Reactor building penetration (typical subcomponents and materials) .....	23
17. RPS pressure channel component input and output .....	31
18. ESPS pressure channel events .....	42
19. RPS regulatory requirements and guidelines .....	54
20. Reactor protection system component materials in containment susceptible to aging .....	62
21. RPS failure modes during operations and cause .....	64

## LIST OF ACRONYMS

ADS	Automatic Depressurization System
ANSI	American National Standards Institute
B&W	Babcock and Wilcox
BWR	Boiling Water Reactor
CE	Combustion Engineering
CIAS	Containment Isolation Actuation System
CM	Corrective Maintenance
CRDCS	Control Rod Drive Control System
CSS	Core Spray System
DBE	Design Basis Event
EAS	Essential Auxiliary Supporting
ECCAD	Electrical Circuit Characterization and Diagnostic System
EI	Edison Electric Institute
EHC	Turbine Electrohydraulic Control
EQ	Equipment Qualification
ES	Engineered Safety system
ESF	Engineered Safety Feature
ESFAS	Engineered Safety Features Actuating System
ESPS	Engineered Safeguards Protective System
ETS	Emergency Trip System
FSAR	Final Safety Analysis Report
FWP	Feedwater Pumps
GE	General Electric
HPCI	High Pressure Coolant Injection
HPI	High Pressure Injection
HVAC	Heating, Ventilation, and Air Conditioning
I&C	Instrumentation and Control
IEEE	Institute of Electrical and Electronic Engineers
INEL	Idaho National Engineering Laboratory
INPO	Institute of Nuclear Power Operation
ISM	Inspection, Surveillance, and Monitoring
LCO	Limiting Conditions for Operation
LER	Licensee Event Report
LOCA	Loss of Coolant Accident
LPCI	Low Pressure Coolant Injection
LPI	Low Pressure Injection
MFP	Main Feed Pump
NDE	Nondestructive Examination
NI	Nuclear Instrumentation
NP&R	Nuclear Plant Aging Research

NPE	Nuclear Power Experience
NPRDS	Nuclear Plant Reliability Data System
NSSS	Nuclear Steam Supply System
O&M	Operation and Maintenance
OMS	Overpressure Mitigating System
PM	Preventive Maintenance
PR	Power Range
PRA	Probabilistic Risk Assessment
PWR	Pressurized Water Reactor
RB	Reactor Building
RC	Reactor Coolant
RCS	Reactor Coolant System
RHR	Residual Heat Removal
RPS	Reactor Protection System
RTD	Resistance Temperature Detector
RTS	Reactor Trip System
SI	Safety Injection
SRP	Standard Review Plan
UC	Unit Control
USNRC	U.S. Nuclear Regulatory Commission
W	Westinghouse

# NUCLEAR PLANT-AGING RESEARCH ON REACTOR PROTECTION SYSTEMS

## INTRODUCTION

The U.S. Nuclear Regulatory Commission (USNRC) initiated the Nuclear Plant-Aging Research (NPAR) Program to obtain a better understanding of how degradation due to aging of key components could affect nuclear plant safety if not detected before loss of functional capability, and how the aging process may change the likelihood of component failures in systems that mitigate transients and accidents and, therefore, reduce safety margins. The possibility of aging degradation causing such events to be initiated is also a concern.

The subject of this report is an in-depth engineering study of the Reactor Protection System (RPS) to achieve NPAR goals as stated in NUREG-1144.<sup>1</sup> These goals are to:

1. Identify and characterize aging and service wear effects associated with electrical and mechanical components, interfaces, and systems likely to impair plant safety
2. Identify and recommend methods of inspection, surveillance, and condition monitoring of electrical and mechanical components and systems that will be effective in detecting significant aging effects before loss of safety function so that timely maintenance and repair or replacement can be implemented
3. Identify and recommend acceptable maintenance practices that can be undertaken to mitigate the effects of aging and to diminish the rate and extent of degradation caused by aging and service wear.

The NPAR Program is being conducted at several national laboratories, including the Idaho National Engineering Laboratory (INEL). Other work at the INEL related to this RPS aging study includes an aging failure survey of light water reactor safety systems and components<sup>2</sup> and the development of technical criteria for use in assessing the residual life of the major light water reactor (LWR) components.<sup>3</sup> The aging failure survey work identified safety systems significantly affected by aging phenomenon, of which RPS is included, and calculates unavailabilities and risk. Although many

component failures were identified in the aging failure survey, the actual RPS system failure occurred only in 0.2% of the component failures. This is due to channel redundancy and priority maintenance. Cables and connectors in containment are listed as one of the top 11 major LWR components that are important to life extension in the residual life assessment overview. Cables and connectors are also important components in the RPS.

This study addresses the system aspects of RPS and materials susceptible to aging in components associated with RPS. Specific components, such as pressure transmitters, platinum resistance thermometers, breakers, relays, and electronic components have been extensively studied by other laboratories for aging effects, equipment qualification, and radiation effects.<sup>4-6</sup> Operating experience from generic data bases and plant records on the RPS are complemented by data from the component studies where applicable.

The RPS includes both the Reactor Trip System (RTS) and the Engineered Safety Features Actuating System (ESFAS). The RPS was studied because of its control importance in initiating all support system functions in the plant safety hierarchy. The understanding of RPS, and any aging-related degradation of that function, is a prerequisite to understanding system interactions within the safety hierarchy.

Information sources used include: the Nuclear Power Experience (NPE) data base, Licensee Event Reports (LERs), Nuclear Plant Reliability Data System (NPRDS), plant-design information and specifications, operation and maintenance (O&M) manuals and procedures, historical records, site-event records, and site interviews with maintenance personnel. The detailed study on RPS is based on a representative Babcock and Wilcox (B&W) plant. Specific plant information was supplied by Duke Power Company.

Figure 1 is a diagram from Reference 7, modified to show system boundaries for equipment to be included in the RPS aging study. This study includes the instrumentation and control (I&C) part of the RPS, which provides automatic safety control actuation functions and is shown inside the short dashed-line boundary.

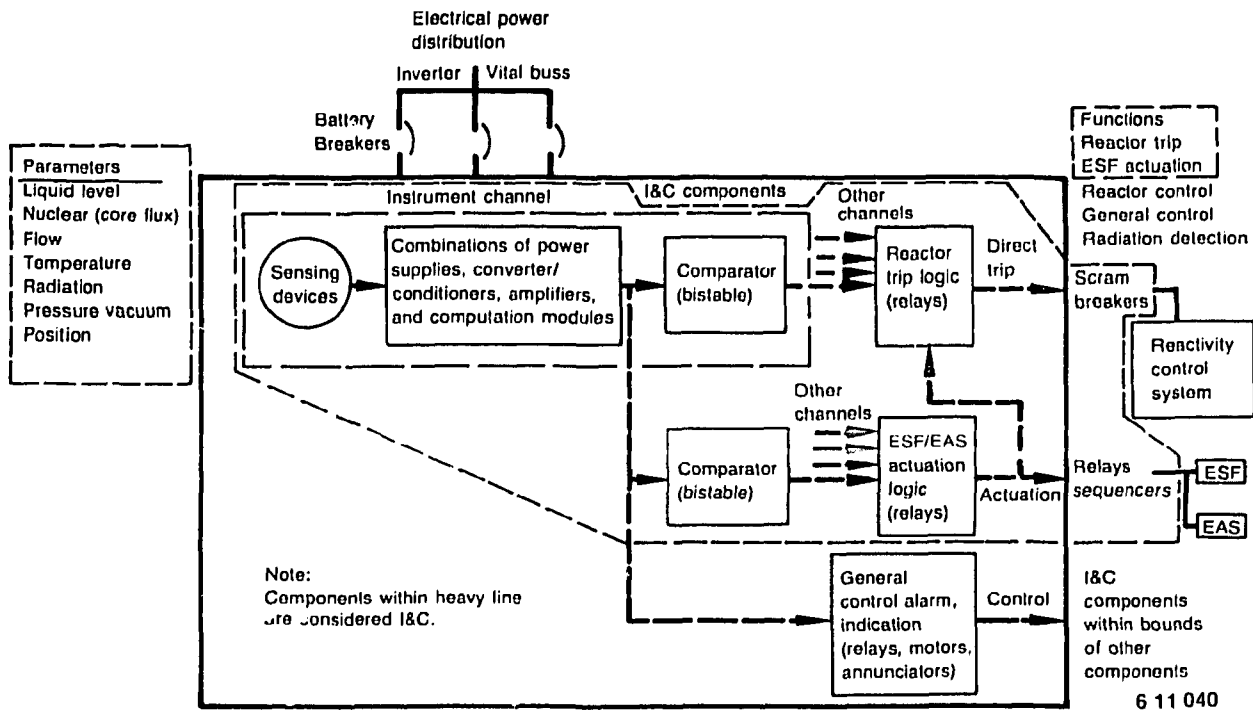

Figure 1. Simplified diagram showing boundary for generic RPS aging study.

Scram breakers are included only to the extent that they affect the system. Other studies have extensively covered breakers (see Appendix B). Specifically, the focus is on actuating functions (sensing, signal processing, comparison, and logic) excluding other I&C functions (actuation, general control, alarm, and indication).

This work on RPS was started initially to study the effects of testing cycles and trips on system degradation, because test cycling was believed to be wearing out equipment. However, it soon became apparent that testing, cycling, and trips were just one aspect of the aging process; thus, this study became part of the aging program.

The information from the various data bases is presented in the section on review of operating experience. This is followed by the RPS detailed study, which has subsections on sensors, cables, penetrations, RTS, and ESFAS. Essential auxiliary systems and interfaces are discussed briefly. Regulatory issues, adequacy/inadequacy of the current testing program, and products for the NPAR Program are covered next, followed by the conclusions.

An evaluation of information sources for aging research on reactor protection systems is given in Appendix A. Scram breakers are discussed in Appendix B and relays in Appendix C.

## OBJECTIVES

The objectives of this study are:

1. Review operating experience and practices of commercial nuclear power plants to determine the significance of aging as a contributor to degradation of RPS.
2. Perform a detailed generic study of the RTS and ESFAS for a representative pressurized water reactor (PWR) using the representative plant's design information, specifications, O&M manuals, and historical records. For each type of instrument channel used in these systems, identify the materials and components that experience degradation due to aging in the various plant environments and operating modes.
3. Identify the essential auxiliary support systems for the RPS.
4. Review regulatory issues pertinent to the RPS and the utilization of research results in the regulatory process, including relevant standards and technical specifications.
5. Assess the adequacy/inadequacy of current testing programs based on findings in the above tasks.
6. Based on the information collected on RPS from the various data bases, plant records, and site visits, summarize the products asked for in the Phase I NPAR guidelines. These are:
  - a. Provide preliminary identification of materials susceptible to aging degradation.
  - b. Determine stressors and related environmental factors causing aging degradation for both normal operation and accident conditions.
  - c. Identify failure modes experienced during operation and their causes.
  - d. Identify functional indicators of degradation that may occur during plant life due to aging.
  - e. Determine the current inspection, surveillance, and monitoring (ISM) methods.
  - f. Determine the role of current maintenance practices in mitigating the effects of aging.

The information from the various data bases is presented in the section on review of operating experience. This is followed by the RPS detailed study, which has subsections on sensors, cables, penetrations, RTS, and ESFAS. Essential auxiliary systems and interfaces are discussed briefly. Regulatory issues, adequacy/inadequacy of the current testing program, and products for the NPAR program are covered.

## REVIEW OF OPERATING EXPERIENCE

This review is put together from the LERs, the NPE data base, NPRDS data base, plant records, and nuclear plant maintenance personnel interviews. An evaluation of the various information sources is given in Appendix A.

### LER Data Base

The Idaho National Engineering Laboratory (INEL) instrumentation and control (I&C) LER data base contains information on LERs submitted to the USNRC for a 6-year period covering 1976 through 1981. This information was encoded in the NPRDS format for risk assessment and statistical analysis, and (for the RTS/ESFAS study) was sorted by system, Nuclear Steam Supply System (NSSS) vendor, plant, and date. However, only reactor trip is coded under the system category; ESFAS is not. For this reason, only the RTS system data were used from this source.

A total of 945 events was reported involving PWR trip systems and 456 events for boiling water reactor (BWR) trip systems. The average number of events for RTS per plant per year is shown in Table 1 by NSSS vendor.

The leading causes for RTS events are listed in Table 2. Although percentages vary, the top five causes are the same for PWRs and BWRs. Drift is the cause most often listed; piece part failure is second. Testing is not listed as a cause, other than personnel error during testing.

Faults discovered by testing are 63%, while 34% were discovered during normal operations, and other faults are 3%. The LER data base classifies events as *age-related* (time in service), *frequency-of-use-related* (demand), or *no classification could be*

*made* (other). For all LER data, the percent of faults classified by frequency of use is 25%; by time in service, 56%; and no classification, 19%. The testing contribution to degradation is buried in the demand classification. By sorting out all the nonaging-related events (such as those caused by maintenance, design, or personnel errors not related to testing) and classifying them according to either demand or time in service, the percentage of demand-related events for each NSSS vendor is obtained as shown in Table 3. Because functional testing is a demand-related event, a large portion of the events in Table 3 could be attributed to testing.

**Conclusions from Review of LER Data Base.** The INEL I&C LER data base contained 1,402 events on RTS for all U.S. nuclear power stations over the 6-year period from 1976 to 1981. For both PWRs and BWRs, the leading cause for RTS events was drift, followed by piece-part failure. Testing was not listed as a cause under the coding system used. However, there was a classification for demand-related events for which a large portion could be attributed to functional testing. The demand failure rate was defined as the probability (per demand) that a component will fail to operate when required to start, change state, or function. Demand events accounted for 25% of all LER events. On the average, there are about 4.6 RTS faults per plant per year and it is estimated that there are about 100 demands a year due to testing. Thus, the ratio of 100 (demands due to testing) to 104.6 (demands due to testing and faults) would be the part of the demand events due to testing, this would be  $(100 \div 104.6)$  times 25% or about 24% of the total events.

**Table 1. Average number of RTS faults per plant-year by NSSS vendor**

NSSS Vendor	Trip System Faults (average one plant/y)	Number of Plants in Survey
W	5.2	31
CE	6.5	8
B&W	2.6	9
GE	4.0	24

**Table 2. LER event cause ranking for RTS events**

Ranking	BWR	%	PWR	%
1	Drift <sup>a</sup>	28.2	Drift <sup>a</sup>	54.1
2	Piece part failure <sup>a</sup>	22.5	Piece part failure <sup>a</sup>	11.6
3	Unknown	20.1	Unknown	8.6
4	Personnel maintenance	4.3	Personnel maintenance	6.
5	Electrical malfunction <sup>a</sup>	3.8	Electrical malfunction <sup>a</sup>	5.1
6	Leaking or blocked <sup>a</sup> sensing lines	3.6	Defective procedures	3.1
7	Environment	3.1	Mechanical malfunction <sup>a</sup>	3.1
8	Dirty/binding/sticking <sup>a</sup>	3.1	Dirty/binding/sticking <sup>a</sup>	2.0
9	Defective procedure	2.8	Personnel operation	2.0
10	Design error	2.3	Fab/const/QC	1.8
11	Mechanical malfunction	2.2	Design error	1.1
12	Personnel operations	1.9	Leaking or blocked <sup>a</sup> sensing lines	0.4

a. Potentially aging-related.

## NPE Data for RTS and ESFAS Generic Study

**Table 3. Percent demand-related faults for each NSSS vendor**

NSSS Vendor	Demand-Related Faults (%)
GE	24.3
W	26.4
CE	32.8
B&W	28.0

**NPE Data System Description.** The NPE Automated Retrieval System was developed and introduced in 1972 by the S. M. Stoller Corporation at Boulder, Colorado. This system contains information on BWRs and PWRs available from the public domain. As of June 1985, the NPE system contained 24,355 articles on more than 50,000 events. The index and key words are computerized, allowing a rapid search of the system for specific articles with titles and reference numbers to the hard copy volumes. The system is updated monthly and appears to be a convenient way to obtain generic information on problem areas. However, the system has no capability, at present, to retrieve component information by the name of individual vendors other than major NSSS.

**Use of NPE for the RTS/ESFAS Study.** The NPE was used to obtain various computer sorts on articles relating to RTS/ESFAS systems and components, as well as NSSS and plants. The percent of articles relating to a key word in the category being searched is used as a rough indicator of problem areas. As with any data base, inconsistencies in event reporting (from the large number of sources) have to be taken into account when interpreting the data.

From this data, one should be able to determine what parts of the RTS/ESFAS systems are reported most often as having problems, as well as the most frequent causes and effects of the events. However, degradation due to testing and aging are not listed as a cause for the events. Thus, they have to be inferred by subjective judgment from the other causes listed.

The NPE data base search included approximately 25 years (1960 to June 1985), in which 2,487 events on RTS/ESFAS were reported on all operating U.S. nuclear plants. The percent of articles (by year) is given in Table 4.

The RTS/ESFAS data base was sorted by NSSS vendor because of the design differences between the BWR and PWR (and among the three PWR designs). The four vendors are General Electric, Westinghouse, Combustion Engineering, and Babcock and Wilcox.

For each of the NSSS vendors, the data base was divided into RTS and ESFAS. The RTS data are presented first.

**Reactor Trip Systems.** The NPE data base classifies the RTS as part of the I&C classification. The RTS systems include manual or automatic reactor trip channel actuation and consequent control rod scrambling on the following indications:

#### BWRs

Hi neutron flux  
 Hi reactor pressure  
 Hi drywell pressure  
 Lo reactor water level  
 Scram disch vol hi level  
 Main steam line hi R/A  
 MSIV closure  
 Lo condenser vacuum  
 Main turbine stop valve closure  
 Turbine Electrohydraulic Control (EHC) valve fast closure  
 Lo EHC oil pressure  
 Loss of RPS power  
 Mode switch in shutdown.

#### PWRs

Overtemp delta temp  
 Overpower delta temp  
 Hi neutron flux (power, intermediate, source ranges)  
 +/- neutron flux rate  
 Hi pressurizer pressure  
 Lo lo SG level  
 Lo FW flow  
 Safety Injection (SI)  
 RTS/RPS systems also include coolant loop RTDs.

The RTS events are sorted by component, subcomponent, and cause. The percentages shown in the tables are of the number of articles on RTS in the data base for each of the NSSS vendors. These are:

1. General Electric (GE)	450 articles
2. Westinghouse (W)	663 articles
3. Combustion Engineering (CE)	275 articles
4. Babcock and Wilcox (B&W)	122 articles.

**RTS Components.** A summary of events related to RTS components is presented in Table 4. There are two columns under each vendor. The percentage for each major group of components is given on the left. The percentages in parentheses on the right of the column are a breakdown of the major component group just above on the left. A component is defined in NPE as the largest entity of hardware for which data are most generally collected. For example, a pressure-sensing channel would be a component with the sensor, amplifier, and signal conditioner being subcomponents. For W plants, the events are fairly evenly distributed over channels for pressure, flow, temperature, and level. The same is true for B&W, except pressure has a higher percentage because of more pressure channels than temperature or level channels. Combustion Engineering has more radiation events than those for flow; GE has more events on level and radiation than flow and temperature.

In addition to the I&C components that apply directly to the RTS as defined in this report, other components from actuated or support systems such as valves, pumps, and tanks are also included in NPE as part of the RTS. The reason for this is that the definition of RTS has varied over the years among different NSSS vendors and utilities. For example, the RTS (in B&W system descriptions) is made up of components from the RPS and the control rod drive control system. For this reason, there

**Table 4. RTS component summary**

<u>Component Selection Menu</u>	<u>BWR</u>		<u>PWR</u>					
	<u>GE</u>	<u>(%)</u>	<u>W</u>	<u>(%)</u>	<u>CE</u>	<u>(%)</u>	<u>B&amp;W</u>	<u>(%)</u>
Instrumentation & Control	59	—	63	—	74	—	62	—
Pressure	—	(19)	—	(19)	—	(28)	—	(29)
Flow	—	(3)	—	(17)	—	(4)	—	(16)
Temperature	—	(2)	—	(18)	—	(23)	—	(12)
Level	—	(41)	—	(20)	—	(10)	—	(12)
Radiation Monitor	—	(18)	—	(4)	—	(10)	—	(7)
Position Indication	—	(4)	—	(1)	—	(1)	—	—
Heat Tracing	—	—	—	(<1)	—	—	—	—
Under/Over Volt/Current Protection	—	(2)	—	(10)	—	(12)	—	(10)
Other & Unknown	—	(11)	—	(10)	—	(12)	—	(14)
<u>Essential Auxiliary Systems, Interface Components, and Other Components Listed Under RTS in NPE Data System</u>								
Electrical	11	—	12	—	10	—	15	—
Valves	19	—	12	—	2	—	3	—
Pumps	1	—	<1	—	<1	—	5	—
Tanks	<1	—	7	—	4	—	2	—
Other, Misc.	9	—	5	—	9	—	13	—
Number of Articles	450		663		275		122	

would be some variance in reporting components associated with the RTS. Also, some events involve multiple components and common cause. Approximately one-third of the RTS events in the NPE fall into component categories other than I&C.

**RTS Subcomponents.** Table 5 depicts the detailed failure events for subcomponent categories. While no one category stands out for all four NSSS suppliers, the five highest categories overall appear to be: sensors, transmitters, electronic parts, bistables, breakers, and power supplies. Sensing lines are also high for GE, W, and B&W plants. While sensors and transmitters are ranked high on the list of subcomponents, total failure of a pressure transmitter for example, occurs relatively infrequently. Drift accounts for 55% of the total number of problems with pressure transducers and total failure occurs for only 15% of the events

reported for pressure transducer problems.<sup>4</sup> The measurement channel subcomponents are discussed further in the RPS Detail Study section of this report.

**RTS Cause.** The causes for events reported in NPE articles may be background, contributory, proximate, or root causes of the failures and irregularities that are narrated. Primary and secondary causes are not distinguished. The various causes are listed in Table 6. For GE plants, operator/maintenance error is listed most frequently. For W and CE plants, local I&C failure is the largest cause category. In B&W plants, the support-systems failures are the most frequent cause. The cause categories marked with an *a* are directly related to aging. More information is needed in some categories to determine if aging or testing is the only cause. A part of the operation/maintenance error is probably due to testing, because testing is often part of maintenance.

**Table 5. RTS subcomponent summary**

<u>Subcomponent</u>	<u>GE (%)</u>	<u>W (%)</u>	<u>CE (%)</u>	<u>B&amp;W (%)</u>
Sensors, transmitters	4	18	17	12
Electronic parts	8	16	14	9
Bistable	21	4	7	11
Breakers	5	11	9	12
Power supply, fuse	7	7	10	13
Sensing line, instrument piping	14	9	<1	7
Wire, cable, connectors	6	6	13	4
Diaphragm, stem, rotor, shaft	7	4	5	10
Relays	7	5	9	4
Switch, valves	7	7	7	3
Hardware, case, fasteners	5	6	3	8
Seals	2	2	2	2
Other, miscellaneous	7	5	3	5
Number of events	450	663	275	122

**Table 6. RTS event cause summary**

<u>Cause</u>	<u>GE (%)</u>	<u>W (%)</u>	<u>CE (%)</u>	<u>B&amp;W (%)</u>
Operator, maintenance error	26	16	10	13
I&C component failure <sup>a</sup>	7	19	21	7
Design, construction error	10	10	13	9
Mechanical wear, broken, damaged or sticking <sup>a</sup>	10	11	9	11
Drift <sup>a</sup>	6	9	9	10
Short, grounding, arcing <sup>a</sup>	8	7	7	11
Support system failure (electrical, cooling, heating, oil)	6	3	9	14
Fouling, blockage, foreign material	2	5	8	7
Environment (thermal, vibration, moisture) <sup>a</sup>	4	6	3	6
Overload, overpressure	4	5	3	5
Normal wearout <sup>a</sup>	5	3	2	2
Corrosion <sup>a</sup>	2	<1	<1	—
Other, miscellaneous	10	5	5	5
Number of events	450	663	275	122

a. Potentially aging-related items.

**Conclusions from NPE Reactor Trip System Study.** A significant fraction of the problems have occurred in the pressure, flow, temperature, level, and radiation monitoring I&C components of the RTS systems. The RTS subcomponents that have contributed most often to these events include: the sensors and transmitters; electronic parts; bistables; breakers; and power supplies and fuses. A wide variety of causes are listed for these failures including the possible age-related causes of: I&C-component failure; mechanical wear, broken, damaged, or sticking; drift; short, grounding, arcing; environment; normal wearout; and corrosion. Less than one-half of the event causes appear to be age-related. Therefore, an unknown, but somewhat smaller fraction of the total failures are due to testing and cycling (because some of the age-related failures are clearly not demand related).

**Engineered Safety Features Actuating System (ESFAS).** The NPE data base also classifies the ESFAS as part of I&C. The ESFAS operates in conjunction with the RPS to initiate the following safety systems automatically:

BWRs

High Pressure Coolant Injection (HPCI)  
Automatic Depressurization System (ADS)  
Core Spray System (CSS)  
Low Pressure Coolant Injection (LPCI) mode of Residual Heat Removal

PWRs

Safety Injection (SI)  
Containment Spray  
Containment Isolation Actuation System  
Boron Injection  
Overpressure Mitigating System

The number of articles on ESFAS for each of the NSSS vendors is: GE (448), W (484), CE (418), and B&W (246). Many of the RTS comments on Tables 4 through 6 also apply to the ESFAS tables; therefore, the ESFAS tables are discussed only briefly here.

**ESFAS Components.** As can be seen in Table 7, the I&C components (as defined in this report) make up about 52% of the events under ESFAS in the NPE data base. The events listed under pumps, valves, electrical, and other are either supporting systems or actuated systems.

**ESFAS Subcomponents.** The ESFAS Subcomponent Summary (Table 8) breaks the items into two categories: (1) those that apply directly to ESFAS as defined in this report, and (2) those that are part of the support and actuated systems. The distribution of events seems to be spread over all subcomponent groups, with none being a dominant problem area except GE bistables. However, switches and breakers are lower for GE, so the 30% for GE bistables in Table 8 probably includes switches and breakers that were not separated out in the reporting process.

**ESFAS Cause.** From the summary on causes for ESFAS events (Table 9), it is interesting to note that human errors in operation/maintenance and design/construction top this list. This data base includes all plants from day one of operation.

**Conclusions from NPE ESFAS Data.** In general, the events for components, subcomponents, and causes are experienced by all NSSS vendors in about the same proportion. Degradation due to testing is not readily deduced from the data, but rather is part of many of the categories marked as potentially aging-related in Table 9. Approximately 47% of the causes for ESFAS events are potentially aging-related. A portion of the maintenance human error is, no doubt, testing-related, because testing is associated with maintenance activity.

## **Nuclear Plant Reliability Data System (NPRDS)**

The NPRDS was developed by the Equipment Availability Task Force of the Edison Electric Institute (EEI) in the early 1970s under the direction of the American National Standards Institute (ANSI). The NPRDS was maintained by the Southwest Research Institute under contract to the EEI through 1981. Since January 1982, the NPRDS has been under the direction of the Institute of Nuclear Power Operations (INPO). Before 1982, participation by utilities was through voluntary agreements, and the system was plagued by noncompliance. Since INPO took over the NPRDS, they have been working to correct the inconsistencies and make other changes to improve the system.

The NPRDS data for all W and GE plants were compiled on RTS, and the aging fraction determined. Aging fraction is the ratio of aging-related

**Table 7. ESFAS component summary**

<u>Component Selection Menu</u>	<u>BWR</u>		<u>PWR</u>					
	<u>GE</u>	<u>(%)</u>	<u>W</u>	<u>(%)</u>	<u>CE</u>	<u>(%)</u>	<u>B&amp;W</u>	<u>(%)</u>
Instrumentation & control	58	—	47	—	52	—	52	—
Pressure	—	(38)	—	(21)	—	(36)	—	(25)
Flow	—	(10)	—	(25)	—	(5)	—	(13)
Temperature	—	(6)	—	(4)	—	(14)	—	(<1)
Level	—	(29)	—	(12)	—	(9)	—	(7)
Radiation monitor	—	(2)	—	(6)	—	(7)	—	(9)
Position indication	—	(1)	—	(1)	—	—	—	(<1)
Heat tracing	—	—	—	(<1)	—	(2)	—	(<1)
Under/over volt/current protection	—	(<1)	—	(5)	—	(<1)	—	(4)
Other & unknown	—	(14)	—	(25)	—	(27)	—	(39)
<u>Essential Auxiliary Systems and Actuated System Components Listed Under ESFAS in NPE</u>								
Electrical	6	—	14	—	13	—	12	—
Valves	22	—	16	—	21	—	15	—
Pumps	6	—	11	—	6	—	11	—
Other, miscellaneous	8	—	12	—	8	—	10	—
Total number of events	448		484		418		246	

**Table 8. ESFAS subcomponent summary**

<u>Subcomponent</u>	<u>GE (%)</u>	<u>W (%)</u>	<u>CE (%)</u>	<u>B&amp;W (%)</u>
Bistables	30	7	7	9
Sensors/Transmitters	4	12	13	10
Wire/cable/connectors	8	7	11	9
Power supplies, fuse	4	7	8	14
Electronic parts	4	9	9	7
Relays	6	6	8	8
Sensing line	12	5	2	6
Seals	3	2	3	3
<u>Supporting Systems or Actuated Systems</u>				
Switches	4	15	11	8
Breakers	4	7	11	6
Actuator/drives	5	8	5	6
Moving internal parts	5	2	2	5
Hardware, mounting	4	3	2	4
Indicators	1	2	1	3
All other	6	8	7	2
Number of events	448	484	418	246

**Table 9. ESFAS event cause summary**

<u>Event Description</u>	<u>GE (%)</u>	<u>W (%)</u>	<u>CE (%)</u>	<u>B&amp;W (%)</u>
Operator/maintenance error	24	21	15	16
Design/construction error	11	13	15	15
Component failure <sup>a</sup>	10	10	17	6
Mechanical wear, damage hardware broken, weld failure <sup>a</sup>	14	8	8	10
Short/arcing/ground <sup>a</sup>	10	7	8	15
Drift <sup>a</sup>	8	7	8	6
Environmental, moisture <sup>a</sup> thermal cycles	5	9	5	8
Electrical power, support systems	3	5	6	8
Fouling, clogging, <sup>a</sup> foreign material	5	3	6	5
Overload	3	5	4	4
Normal wearout <sup>a</sup>	3	1	1	1
Corrosion <sup>a</sup>	1	1	1	1
Other	3	10	6	5
All other	6	7	6	2
<b>Total number of events</b>	<b>448</b>	<b>484</b>	<b>418</b>	<b>246</b>

a. Potentially aging-related events.

failures to total number of failures for that component. The results of this sort for the various types of components in the RTS is shown in Table 10. The overall total aging fraction for 3170 failures is 23.3%. This means 23.3% of the reported failures were aging-related. Total loss of system function occurred 6 times for the 3170 component failures. This means that only 0.2% of the component failures cause a system failure. Data from the other NSSS vendors were not compiled.

### Plant Operating Experience from Site Visits and Personnel Interviews

An operating B&W plant was visited and site personnel interviewed. Included in the interviews were the maintenance supervisor, I&C supervisors for Engineered Safeguards Protective System (ESPS) and RPS, and a nuclear instrumentation and electrical specialist. Detailed I&C drawings on ESPS and RPS were reviewed, as well as computer print-outs of corrective maintenance (CM) and preventive maintenance (PM) requests and test procedures for both ESPS and RPS.

Data from the CM records are summarized in Table 11 in the same general format as that used in

the NPE data sorts. For components, the spread of events is distributed over pressure, flow, temperature, and nuclear instruments very similar to that obtained from the NPE data base. At the subcomponent level, sensors/transmitters are listed most often, followed by electronic parts, power supplies, and bistables/comparators. The causes for the problems for which CM was performed in order of frequency of occurrence are electronic component failure, sensor failure, power-supply-capacitor failure, out of calibration, and procedure error.

In general, the testing requirements in the technical specifications are followed. However, additional tests were performed whenever problem areas were encountered or parts replaced. During calibrations, analog readings are recorded for *as-found* and *as-left* conditions. Any component or subsystem more than 2% out of tolerance was reported and received an engineering evaluation and trend analysis. Corrective action based on the engineering evaluation would be taken before the component or subsystem was put back in service.

Excessive drift usually meant that some component had degraded, assuming set points were properly adjusted and limits were not too tight for the application. Most drifts were experienced on power supply voltages. Electrolytic capacitor failure in power supplies is a recent problem. Finding

**Table 10. Aging fractions from operational data on reactor trip system**

System Component <sup>a</sup>	Total Count	Aging Fraction <sup>b</sup> (%)
Instrumentation - Isolation Device	30	36.7
Annunciator	3	33.3
Generator - Alternator - Inverter	16	31.2
Instrumentation - Computation - Module	851	27.6
Instrumentation - Recorder	199	27.1
Circuit Breaker	41	26.8
Instrumentation - Electronic Power Supply	254	25.2
Instrumentation - Controllers	199	24.1
Relay	335	23.0
Electrical Conductor	10	20.0
Instrumentation - Transmitter	753	18.9
Instrumentation - Switch	479	18.8
Total for system	3170	23.3

a. Information based on NPRDS data for all Westinghouse plants.

b. Aging fraction % is the ratio of the estimated aging-related failures to total number of failures for that component.

**Table 11. Plant corrective maintenance data events for RPS**

Components	Percent <sup>a</sup>
Pressure	17
Flow	17
Temperature	14
Nuclear instruments	7
Other	45
Subcomponents	
Sensors/transmitters	25
Electronic parts	22
Power supplies	16
Bistables, components	9
All other	28
Cause	
Electronic component failure	33
Sensor failure	17
Power supply capacitors	14
Out of calibration	7
Procedure error	7
Connectors/terminals	5
Leaks	5
Drift	2
Unknown/other	10

a. Percent based on 45 events.

replacement parts when the original vendor has gone out of business was also a problem. Design problems were encountered when components were obtained from a new vendor. Most drifts are discovered by testing.

Abnormal voltages, currents, or response time are indications of component degradation. The analog readings are recorded at least annually. Control rod drive reactor trip breakers receive quarterly PM and are refurbished routinely. When refurbished, they are also retested.

Procedures were recently changed at the plant to reduce the number of tests on scram breakers. Initially, each breaker test was repeated six times in a row. Now it is repeated only twice. Thus, breakers are tested at least twice a month. This change was made to reduce wear on breakers due to testing. This was done on the plant's own initiative because the number of tests far exceeded technical specification requirements. The I&C technicians believe that quarterly testing of breakers would probably be sufficient, because they receive quarterly PM, and plant experience has shown that quarterly maintenance reduces the number of breaker problems.

**Conclusions from Site Visits.** Actual testing of the RPS and ESPS exceed technical specification by more than a factor of two. Each channel is tested once a month, including the breakers. The breakers receive a second test using local control. Additional testing is performed after any maintenance activity. Excessive drift is an indicator of component degradation. Also, obtaining spare parts when the original vendor has gone out of business is a problem for older plants. Actual plant records reviewed include drawings, O&M manuals, and procedures. For example, the plant CM summary records listed about 31 major work requests for the RPS over a 4-1/2-year period. The LERs had nine events and NPE had seven events for the same 4-1/2-year period. The NPRDS listed eight failures from February 10, 1982, to April 25, 1985, and CM had twenty-two items for this same period. There were also numerous minor work requests in the maintenance records that covered such items as recorder pens not inking and painting cabinets.

## REACTOR PROTECTION SYSTEM DETAILED STUDY

The detailed RPS study includes the sensors, analog and digital circuits, and output logic with relays. A functional description is given, along with the testing scheme used for key portions of the system. The periodic testing requirements are also summarized, as well as the faults that have occurred as compiled in the NPE data bank for the sensor channels. The detailed discussion of these systems (down to the component level) should help the reader better understand the impact, if any, of testing, cycling, and trips, and the aging process on these systems.

### Sensors, Cables, and Penetrations for RTS/ESFAS

The sensors described apply specifically to the representative B&W plant studied, but would be typical for any nuclear plant except where noted. For more detailed information on components aging, see component reports such as References 4 to 6.

The term sensor, as used in the various data banks, includes the associated electronics as well as sensors. The nonnuclear sensors that provide input to RTS/ESFAS systems are of five types, as shown in Figure 2. These are pressure sensors, pressure switches, flow monitors, temperature sensors, and contact monitors. The sensors in containment have a qualified life for a specific number of years. They are replaced at the end of the qualified life period or sooner due to obsolescence when the vendor no longer supports the component or has gone out of business. Discussions with plant maintenance personnel has indicated that sensors and transmitters have not been a significant source of trouble for them.

**Pressure Measurement.** A typical pressure transducer converts the force due to pressure to expansion or contraction of a bourdon tube or bellows. The bourdon tube may be connected to a movable core transformer or a force-balance assembly.

A bellows may have a strain gauge or a variable capacitor attached to change the motion to an electrical signal. The signal-conditioning electronics are usually considered part of the transducer. The typical representation for a pressure measurement channel is shown as *a*. in Figure 2.

Reference 4 is an aging study on pressure transducers and the results of that study are directly applicable to the RPS pressure measurement channels. In that report they conclude that the most common effects of the stresses on the transmitters are calibration shifts and that total transmitter failure occurs relatively infrequently. Under a design basis accident the housing seal integrity is important to keep out moisture, or steam, which could affect the electronics. Periodic operability checks were also recommended to ensure that transmitter problems do not remain undetected.

Basically, three types of pressure transducers are used in nuclear plants—the strain-gauge-pressure transmitter, force-balance transmitter, and differential capacitance. Only the strain-gauge-type and differential-capacitance-type (which are used on the RPS for the representative plant studied) will be discussed here.

**Strain-Gauge Transmitter.** The strain-gauge transmitter is used on the ESFAS system to monitor narrow range reactor building pressure. This pressure information is converted to a 4 to 20 mA signal, which is used to actuate building isolation and cooling.

In a strain-gauge transmitter, the process pressure acts on a bourdon tube that is connected to a cantilevered beam. As the pressure varies, the tube causes the beam, on which a strain gauge is mounted, to deflect. As the beam deflects, the resistance of the strain gauge varies. An electronic circuit detects this variation and provides a proportional output at the terminals of the transmitter.

The primary materials of construction are listed in Table 12. The materials that are subject to aging are indicated by a footnote in Table 12. In general, the organic materials are subject to aging due to temperature and moisture. See component reports for details on component aging (References 4 and 6). The strain-gauge transmitter has a qualified life of 40 years, with no time restriction on storage before installation. However, O-rings and seals used on the transmitter have only a 4-year qualified life.

**Differential-Capacitance Transmitters.** In a differential-capacitance transmitter, a sensing diaphragm, which is the center plate in a three-plate differential capacitor, is moved back and forth between the two stationary capacitor plates by the change in process pressure. The differential capacitance established

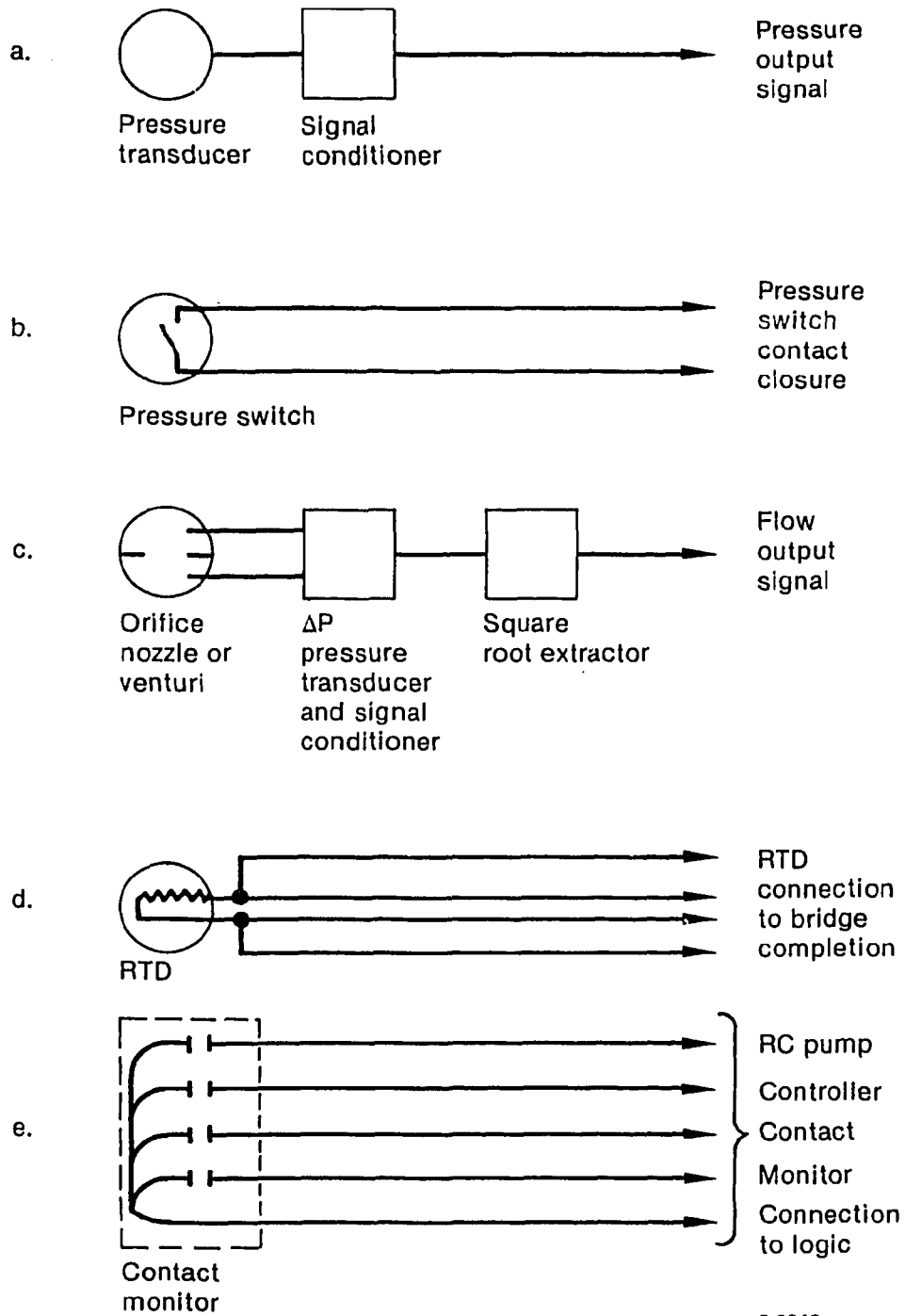

6 0246

Figure 2. Nonnuclear sensors for RTS/ESFAS.

**Table 12. Materials in strain gauge pressure transducers**

Item	Material or Component
Pressure connection and bourdon tube	Haynes Alloy No. 25
Housing	Steel
Printed circuit board	Epoxy-glass laminate <sup>a</sup>
Electronics components	Seals and insulating <sup>a</sup> materials used on electronic components
Potentiometers	Phenolic body, nylon rotor, slider <sup>a</sup>
Conformal coating	Silicon based
Housing O-rings	Ethylene-propylene diene monomers <sup>a</sup> (EPDM)
Lead wire	Copper
Lead insulation	Tefzel

a. Materials subject to aging degradation.

between the fixed capacitor plates and the moving plate of the sensing diaphragm is converted by an electronic circuit to a 4 to 20 mA dc signal that is proportional to the detected pressure.

The  $\Delta P$  transmitter is qualified for 10 years based on manufacturer's thermal test data, at the expected 120°F average temperature in the reactor building. Cyclic testing for expected operational, environmental, and maintenance stressors exceeded the 10-year thermal life, with a 20-year test goal. The primary materials of construction are shown in Table 13. See References 4 and 6 for component aging effects.

**Pressure Switch.** The pressure switch utilizes a bellows to open or close electrical contacts at a preset pressure. It has fewer parts and less sensitivity than a pressure transducer (see *b.* in Figure 2). Typically, a pressure switch will have a stainless steel and teflon-covered diaphragm with a snap-action switch and will be qualified for a 10-year life.

**Flow Measurement.** Flow is detected by introducing a flow restriction in a pipe and measuring the differential pressure produced by the flow change; i.e., flow is proportional to the square root of differential pressure. This differential pressure is converted to an electrical signal by a differential-pressure detector. The electrical signal is amplified and a square root extractor is used to convert the signal for flow information.

The restriction is referred to as a primary flow element. It may be an orifice, flow nozzle, or ven-

turi tube. Orifices are used in the majority of fluid meters because of low initial cost and easy installation. Nozzles can handle higher flow rates than orifices; venturi tubes are used primarily when it is important to minimize net pressure loss. The major elements in a flow-measurement channel are shown in *c.* in Figure 2. The piping arrangement for reactor coolant flow measurement in the representative plant under study is shown in Figure 3. All flow transmitters for one flow loop are connected to this piping arrangement. The other flow loop would have a similar arrangement.

**Temperature Measurement.** The Resistance Temperature Detector (RTD) is the basic sensing device that converts thermal energy to electrical energy for Class 1E safety systems. The electrical signal is then amplified and used for indication and control.

The RTD consists of a platinum wire wound around a porcelain insulator. The tip of the insulator is embedded in alumina powder for heat conduction from the water to the platinum wire. When the temperature changes, the resistance of the platinum wire alters proportionally. The RTD is connected to one leg of a bridge and as the temperature changes, the output voltage across the bridge changes. The basic RTD channel is shown in Figure 2*d.*

The RTD is qualified for 10-years of operation in the harsh environment of the reactor containment. Materials in the RTD are shown in Table 14. There

**Table 13. Materials in capacitance-type pressure transducers**

---

Item	Material or Component
Housing	Aluminum with epoxy polyester paint or 316 stainless steel
Process flanges	316 stainless steel
Isolation diaphragm	316 stainless steel
Fill fluid	Silicon oil <sup>a</sup>
Circuit boards	Epoxy glass laminate <sup>a</sup>
Electronic components	Seals and insulating <sup>a</sup> materials used on electronic components
Terminal block	Phenolic <sup>a</sup>
Housing seal	Ethylene propylene <sup>a</sup>

---

a. Materials subject to aging degradation.

---

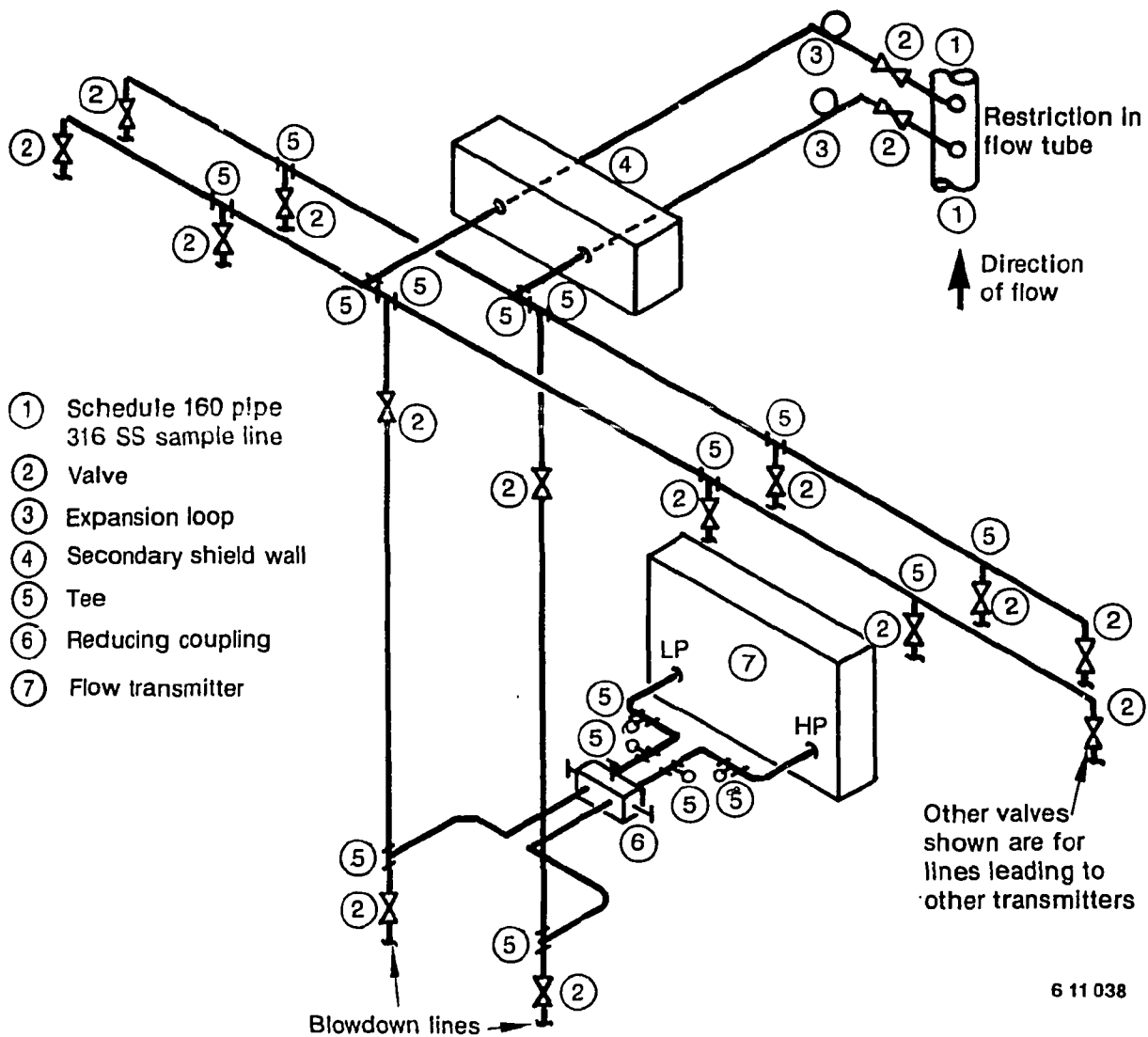

Figure 3. Flow-transmitter piping.

Table 14. Resistance temperature detector (RTD) (Materials)

Component	Material
Sensing wire	Platinum
Insulator	Aluminum oxide powder $Al_2O_3$
Sheath	Inconel X750 or 321 stainless steel
Spring	Stainless steel

have been very few aging-related problems with RTDs in the plant used for the detailed study.

**Contact Monitor.** The contact monitor is on the reactor coolant pump motor controller. When the controller contacts open, a signal is provided for indication and control (see in Figure 2e). This is essentially a power monitor and has the usual electronic measuring components.

**Nuclear Instrumentation.** For the PWR studied, the power-range channel is the only nuclear instrumentation directly interfacing with the RTS. The detector used is a neutron-sensitive ion chamber. Under neutron irradiation, the ion chamber converts neutron-flux intensity into some measurable quantity. The output of this chamber is an electrical signal composed of a

random series of electrical currents. These are a result of the collection of charged ions produced in the chamber volume by the interaction between neutrons and the neutron-sensitive detecting material in the chamber. The number of charges collected per unit time is directly proportional to the neutron-flux intensity.

These ion chambers are designed for operation in the harsh environment around the reactor and have relatively few failures reported.

**Sensor Tests and Calibrations.** The tests and calibrations described here apply primarily to the PWR studied.

**Test and Calibration of Nonnuclear Instrumentation.** All sensors and associated channels are usually tested according to plant test procedures. These tests and calibrations will verify correct readings for each sensor with appropriate input. For example, pressure and flow instruments are checked in place with a test pressure applied. Electronics are calibrated with each instrument using test voltages according to plant (or manufacturer's) procedures. Response times for electronics and relays/breakers are checked as required by technical specifications. However, sensors are not usually checked for response time. If aging changes sensor response time, the normal calibration probably would not pick this up.

**Test and Calibration of Nuclear Instrumentation Power-Range Channel.** For the PWR studied, test and calibration facilities are built into the system to permit an accurate electronic calibration (of the system) and detection of system failures in accordance with the requirements of plant calibration procedures and IEEE 279.

In addition to electronic calibration, the power-range channels are also calibrated against a plant heat balance.

**Cable.** For the PWR studied, the typical nonnuclear instrumentation cable is a single pair No. 16 AWG, twisted together with 2 in. lay, 25 mils cross-linked polyethylene (XLPE), 90% tinned copper braided shield, 45 mils neoprene inner jacket, and galvanized steel interlocked armor overall. The cable is rated 300 volts. Not all plants use the armor cable.

The cable for the nuclear power-range channel is a RG-11/U triaxial, low density polyethylene insulation, polyvinyl chloride (PVC) inner jacket,

20 mils galvanized steel interlocked armor, 60 mils PVC overall jacket, with  $5 \times 10^{12}$  ohm insulation resistance per 1000 ft between center conductor and inner shield. Cable materials are summarized in Table 15.

Cables are presently qualified for 40 years if not moved or *hi pot* tested. Chapter 7 of NUREG-0800 requires installation of qualified components in a manner consistent with IEEE-279. Qualification of cables and splices is covered in Regulatory Guide 1.131.

Further research is needed to determine if the current policy of replacing cables when they fail needs to be supplemented with improved maintenance practices and new predictive techniques, which would allow replacement before failure.

**Reactor Building Penetrations.** Penetrations for the RPS are of two types: piping (instrument tubing) and instrumentation cable.

**Piping Penetrations.** Reactor building pressure transmitters for the ESFAS utilizes a piping penetration through the reactor building wall into the penetration room where the pressure transmitter and pressure switch are located. In addition, the reactor coolant pressure and flow tubing have penetrations through the secondary containment wall in the reactor building.

All piping penetrations are of the rigid-welded type and are solidly anchored to the reactor building wall or foundation slab, thus precluding any requirements for expansion bellows. All penetrations and anchorages are designed for the forces and moments resulting from operating conditions. External guides and stops are provided, as required, to limit motions, bending, and torsional moments in order to prevent rupture of the penetrations and the adjacent liner plate. Piping penetrations have no provision for individual testing because they are of all-welded construction.

**Instrument Cable Penetrations.** A typical low voltage power, I&C assembly is shown in Figure 4. These assemblies are designed to bolt to mating flanges mounted inside the reactor building. Each assembly includes two header plates welded to glass-to-metal sealed conductors. The space between the seal headers is piped to a pressure gauge and a charging valve located outside of the reactor building. This test volume is pressurized with an inert gas. Dual O rings with a test port between are used to complete the seal to the mating flange, which is welded to the penetration nozzle.

**Table 15. Cable materials**

Use	Reactor Building Instruments	Nuclear Instruments
<b>Conductor</b>		
Size	16 AWG	RG 11/CU
Material	CU	CU
Number	2 (shield)	1 (2 shield)
Stranded or solid	Stranded	Stranded
Voltage rating	300	—
Current Rating	90°C	90°C
Max. Continuous Cond. Temp.	90°C	90°C
Insulation resistance ( $\Omega$ /100 ft)	—	5 x 10 <sup>11</sup>
<b>Insulation</b>		
Material <sup>a</sup>	XLPE	PE
Thickness (mils)	25	—
<b>Insulation Jacket</b>		
Material <sup>a</sup>	—	PVC
Thickness (mils)	—	—
<b>Sheath</b>		
Material <sup>a</sup>	Neoprene	Galvanized steel
Thickness	45 Extruded	25 mils
<b>Outer Jacket</b>		
Material <sup>a</sup>	Galvanized steel	PVC
Thickness		60

a. Materials subject to aging degradation.

CU = Copper

XLPE = Cross linked polyethylene

PE = Polyethylene

PVC = Polyvinyl chloride

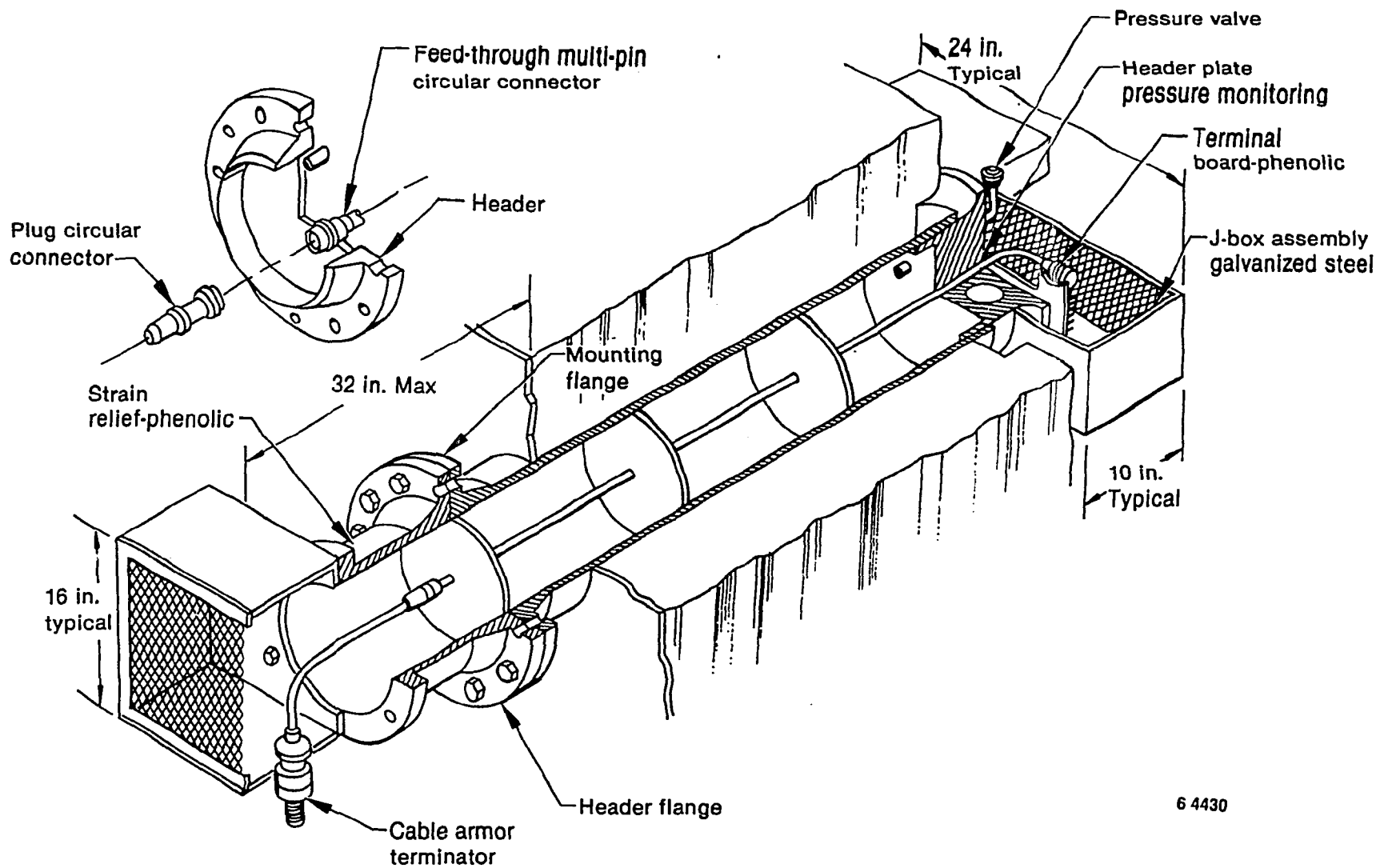

6 4430

Figure 4. Typical instrumentation penetration.

Subcomponents and materials in a typical instrumentation penetration with associated connector are listed in Table 16. Figure 5 shows a typical penetration.

Penetrations are presently qualified for 40 years plus 1 year post Design Basis Event (DBE). Penetrations are pressurized. If loss of pressure is detected, seals may be deteriorated. Visual inspection and end-to-end channel functional checks are other surveillance techniques used to detect failures. These commonly used surveillance methods only locate degraded or catastrophic failures. Aging problems in the incipient stage would go undetected using present surveillance techniques. Advanced monitoring methods are needed for detecting aging of both cables and penetrations.

**Summary and Conclusions for Sensors, Cables, and Penetrations Review.** Each type of sensor used in the RPS was discussed and materials or subcomponents subject to aging were identified for each. Typical cables and reactor building penetrations are also covered. Pressure transducers are widely used not only for pressure, but also in flow and level instrumentation. The evaluation of failure data in LERS, NPE, and NPRDS indicates that total failure of sensors

occurs relatively infrequently. Sensors were high on the list for subcomponent events, but about 55% of these events were due to drift. Total failure occurred in only about 2.7% of the events. Discussions with plant maintenance personnel also confirm that sensors and transmitters are not considered a significant source of trouble. Most are qualified for at least 10 years, except for seals or gaskets, which may be only 4 years. For added assurance, seals are inspected every time the transmitter housing is opened and replaced if any deterioration is noted. This could be as often as every plant refueling outage, if adjustments are required during calibration and maintenance.

Further research is needed to determine if the current policy of replacing cables when they fail needs to be supplemented with improved maintenance practices and new predictive techniques, which would allow replacement before failure. This also holds true for penetrations. The instrumentation penetrations are qualified for 40 years plus 1 year post DBE.

Chapter 7 of NUREG-0800 requires installation of qualified components consistent with IEEE-279, but there is no guidance on indicators of aging of cables.

**Table 16. Reactor building penetration (typical subcomponents and materials)**

Description	Material
Cable clamp	Stainless steel
Terminal strip assembly <sup>a</sup>	Glass filled phenolic
Shrink tubing (outside) <sup>a</sup>	Polyolefin
Plug sleeve and coupling ring	Bronze
O-ring seal <sup>a</sup>	Elastomer
Contact socket	Copper alloy (gold plated)
Interfacial seal <sup>a</sup>	Dow Corning Sylgard
Insulator, plug skirt <sup>a</sup>	Polysulfone
Washer	Stainless steel
Module assembly	Brass

a. Materials subject to aging degradation.

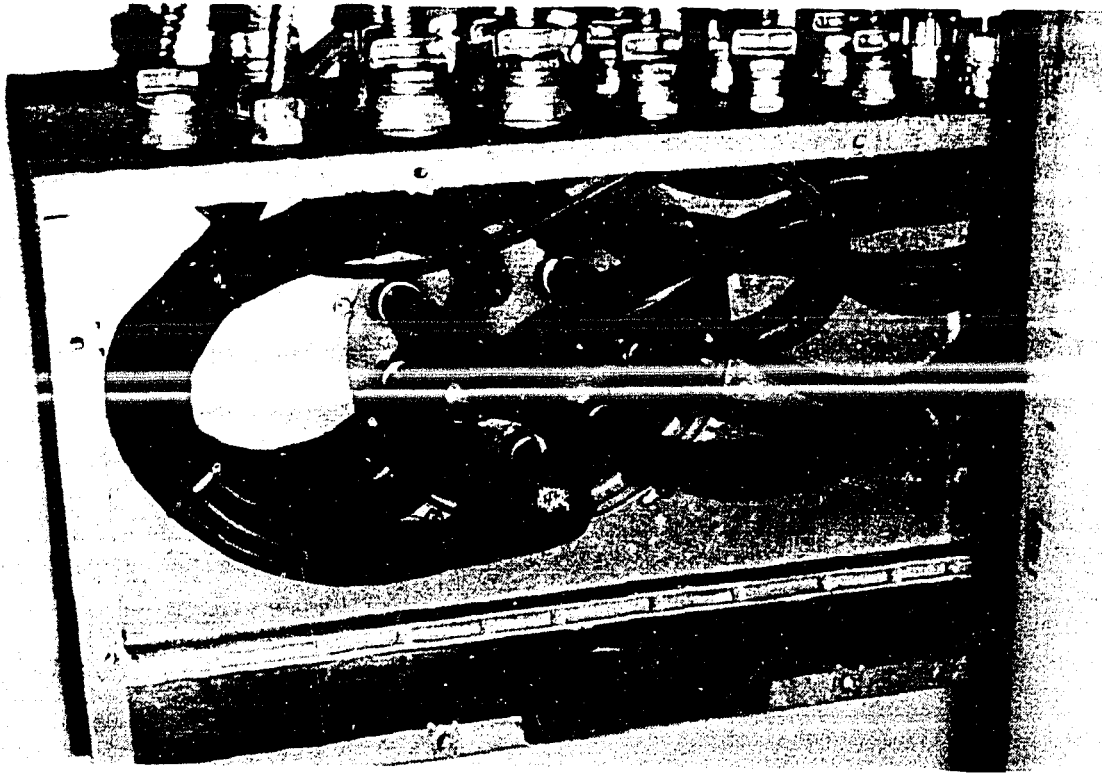

Figure 5. Typical reactor building penetration cables for instrumentation.

## B&W Plant Reactor Trip System (RTS) Description

The RTS, as defined in this report, is called the Reactor Protective System (RPS) on B&W plants.<sup>8</sup> While the description applies to the particular plant studied, it is typical for any B&W plant. Some plants may have more sensors, such as level-sensing channels, which would be very similar to the pressure channel.

The measurement channels associated with each of the trip string bistables is discussed in the following sections, along with related aging information with one-line diagrams. All guidelines, standards, and regulations covering the RPS are discussed later in the section on regulatory issues.

The RPS is a four-channel system that receives redundant inputs from both nuclear and nonnuclear instrumentation. It initiates a reactor trip whenever any two of the four channels agree that a safety limit has been reached. The system is designed to prevent fuel cladding damage and protect the reactor coolant system (RCS) from high-pressure damage.

A reactor protection channel can be tripped by manual action, loss of power, removal of a system module from its cabinet, or any of the safety conditions described later in this report. One of the reactor trip strings is shown in Figure 6.

The trip relays are in series for each channel. All have normally closed contacts; the opening of any one contact set will remove power from the reactor trip module and trip that channel. The reactor trip module is shown expanded in Figure 7. Relay problems associated with the RPS are discussed in Appendix C.

The functions of the reactor trip module are to collect the outputs of the four RPS channels and to initiate a trip signal when two of the four channels signal a trip. There are four reactor trip modules—one module for each RPS channel.

The channel trip OR gate, the first component of the reactor trip module, senses the series input from the channel trip string (Figure 7). If this input is lost, then the OR gate puts out a trip signal via the channel trip memory.

Six trip logic AND gates are used to develop the 2-out-of-4 (2/4) reactor trip logic. These AND gates receive inputs from all four RPS channels. The combinations of AB, AC, AD, BC, BD, and

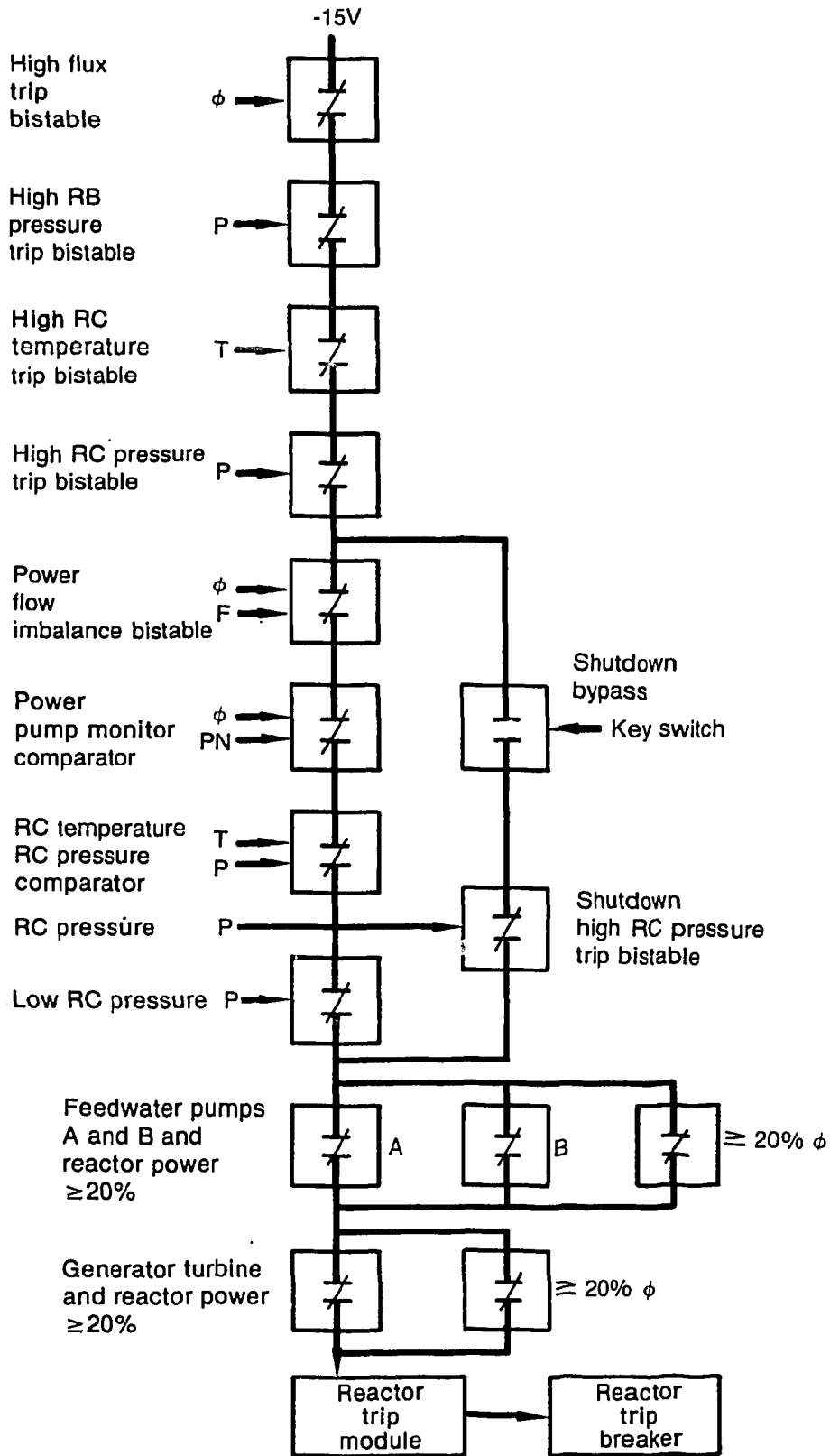

6 11 039

Figure 6. RPS trip string for one channel.

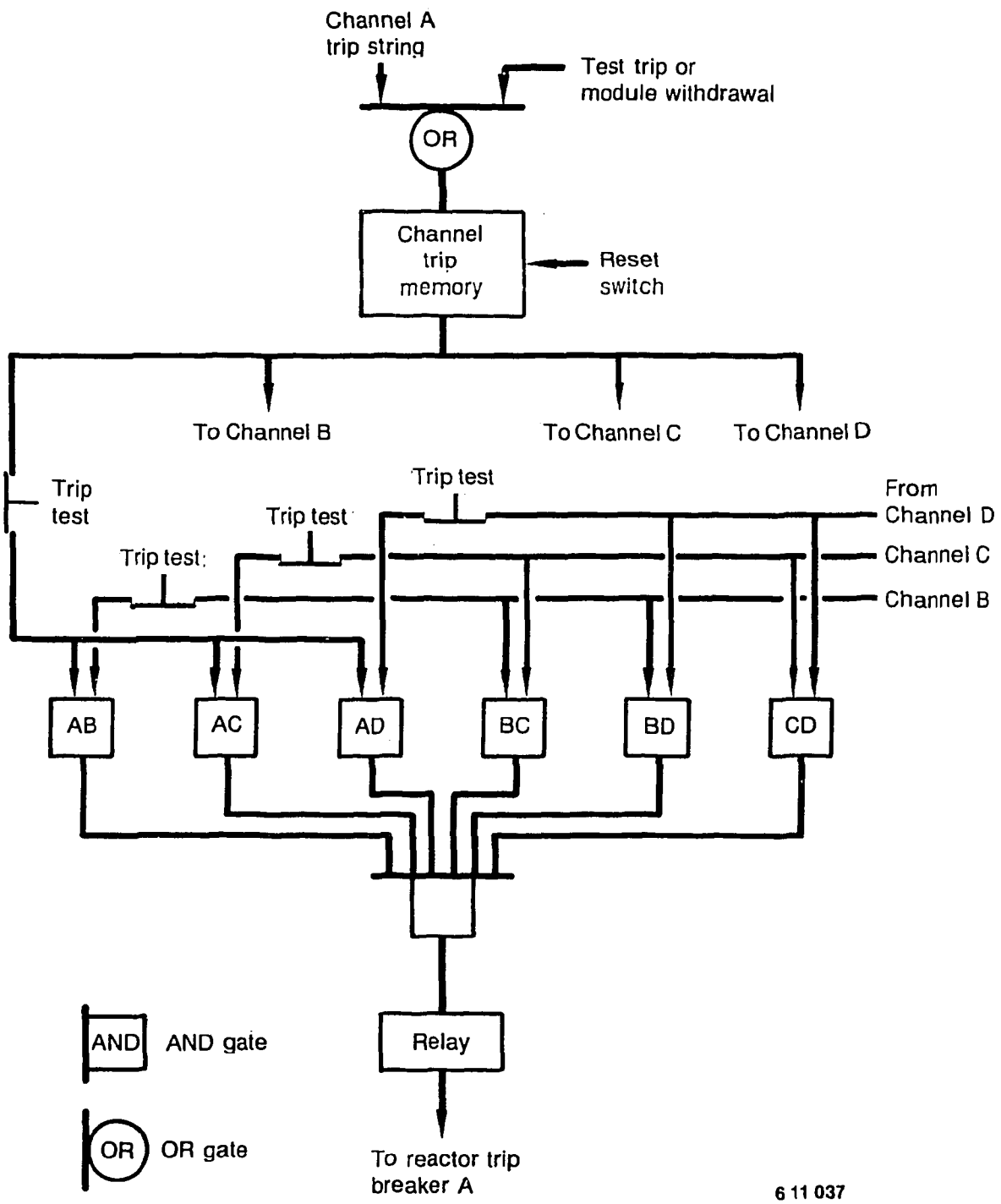

Figure 7. Reactor trip module.

CD as shown in Figure 7 represent all 2-out-of-4 logic conditions.

When the reactor trip module gate senses any trip logic the AND gate is de-energized and an output trip condition (de-energized) is transmitted to the reactor trip device. The reactor trip devices are the scram breakers which are in the power input lines to the control rod drive system. The scram breakers are the actuated part of the RPS and are discussed in Appendix B.

**Shutdown Bypass.** A switch is provided in each protective channel to bypass the following trips: low pressure; pressure/temperature; power/imbalance/flow; and flux/pumps. Operation of the switch above a predetermined low reactor coolant pressure set point trips the channel. If bypass has been established, increasing the pressure (above a predetermined high pressure set point) trips the channel. The shutdown bypass is shown in Figure 6.

#### Reactor Coolant Pressure Measurement Channel

**Pressure Transmitter Piping.** Each of the four reactor coolant (RC) pressure-measurement channels has a tap into the RC piping as shown in Figure 8. Both RPS and ESFAS transmitters are connected to this tap through the piping arrangement shown. Valves and test points are also provided in the piping for calibration purposes. Any blockage in the tubing from the RC pipe to the tee outside the secondary shield wall could affect both RPS and ESFAS channels. The piping is part of the RCS design and any aging effects applicable to pressure boundary piping would apply.

**RC Pressure Channel Description.** The one-line diagram for RC pressure is shown in Figure 9. This diagram illustrates essential components, from the transmitter located in the reactor building to the low pressure trip bistable in the RPS cabinet in the control room. In addition, the chart under the diagram shows various items of interest to the aging study, relative to each of the components. The low pressure bistable is shown in the diagram, but three other bistables receive the same signal at Point A. The only difference is the set point of each of the bistables. The three other bistables are for high pressure trip, pressure-temperature comparator and shutdown bypass. The interface arrangement for these various bist-

ables is shown in the RC temperature and pressure logic diagram in Figure 10. The buffer amplifier acts as a signal conditioner and isolation unit.

All of the modules and circuit components, calibrated and maintained as part of one RPS pressure channel, are listed in Table 17 along with normal input and output signals. Under accident and post-accident conditions, the signals would still be in the ranges shown unless the sensor or other components failed.

**Reactor Coolant Temperature.** The RTD for RC temperature measurement is tapped in to the RC piping in the reactor building. The cable runs through the reactor building penetrations directly to the bridge completion electronics in the RPS cabinet in the control room. A one-line diagram is shown in Figure 11 with aging-related data on the chart below the figure.

**Pressure-Temperature Trip.** The pressure-temperature comparator trips when the relation  $KT - b \geq P$  is reached by a combination of rising temperature or falling pressure. The reactor outlet temperature (T) is in degrees F, and reactor coolant pressure (P) is in psig (K and b are adjustment constants). The temperature measurement interface with the RC pressure comparator was shown in Figure 10.

**Power-Range Channel.** The power-range channel supplies reactor-power-level information continuously to the RPS. The detector is positioned out of core, but adjacent to one of the four quadrants of the core. An uncompensated ion chamber is used in the power-range channel. The power-range detector consists of two 72-in. sections with a single high voltage connection and two separate signal connections. The outputs of the two sections are summed and amplified by the linear amplifiers (in the associated power-range channel) to obtain a signal proportional to total reactor power,  $\phi$ . Likewise, the difference between the two linear amplifiers is an indication of the difference between the reactor flux in the top of the core versus the reactor flux in the bottom of the core,  $\Delta\phi$ . Both the  $\phi$  and  $\Delta\phi$  signals are used as inputs to the power imbalance flow comparator in the RPS. The  $\phi$  signal is also used in the power-pump comparator of the RPS. The power-range-measurement channel is shown in Figure 12 along with related aging information.

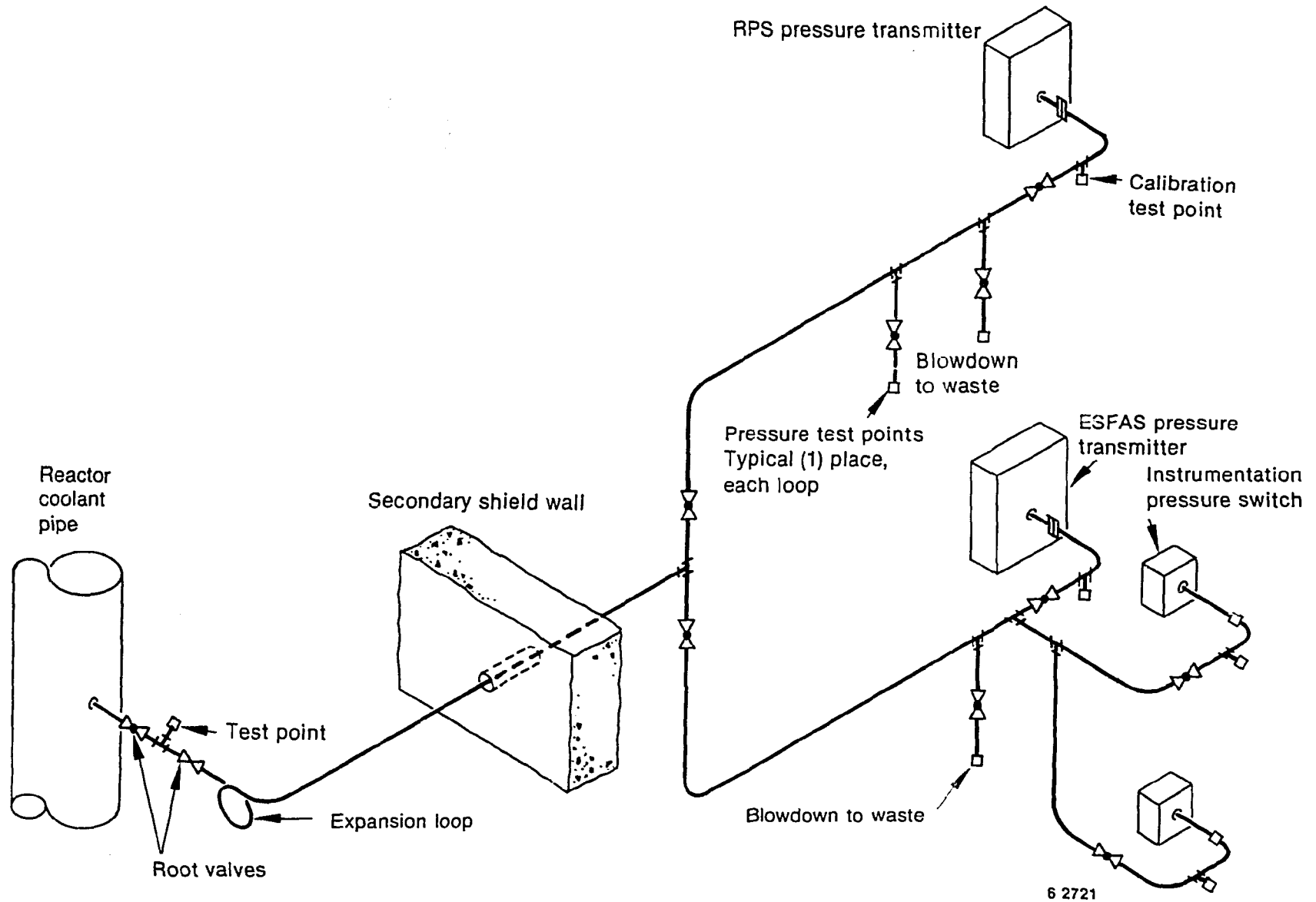
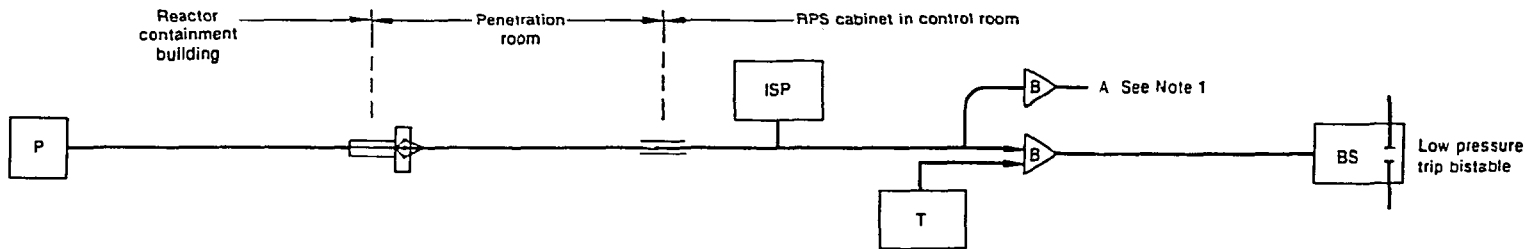

Figure 8. RPS reactor coolant pressure transmitter piping diagram.



Component	Reactor coolant pressure transmitter	Reactor building cable	Reactor building penetration and terminal strip	Penetration room cable (auxiliary building)	Cable feedthrough	Instrument power supply	Test module	Buffer amplifier	Cabinet wire and cable	Bistable (includes trip relay)	Comments
Environment Temperature	120°F average, 130°F maximum			60 to 130°F		50 to 80°F ambient in control room					
Radiation	3 x 10 <sup>4</sup> RAD			1 x 10 <sup>6</sup> RAD		NA					
Interfaces	Pressure tap	None	None	None	110V power and module interlock						
EQ	10-y life	40-y life									
Testing	18 months end-to-end check					Functional testing monthly, response time at 18 months and 18 months end-to-end check					
Calibration	18 months or	NA	NA	NA	Monthly						
Maintenance	Refueling	NA	NA	NA	18 month or refueling						
Signal	4 to 20 mA current loops							± 10 Vdc		Normal or accident	
Physical data				130 ft 1SPA16G.3							
Stressors	Temperature, radiation, moisture and env. cycles					Maintenance, testing cycles and operational trips					
Indicators of degradation	Dirt, moisture intrusion, wearout, failure, signal variance from similar channels	Insulation resistance change, mechanical damage	Inert gas leak, contact corrosion, mechanical damage, insulation resistance change	Insulation resistance change, mechanical damage	Electrolytic capacitor failure, drift, failure	Drift, failure		Loose connection	Dirt, dirty contacts, failure		

Note 1: Point A goes to other bistables (High pressure, bypass, and pressure/temperature comparator)

Figure 9. RPS reactor coolant pressure channel with supporting aging and engineering data.

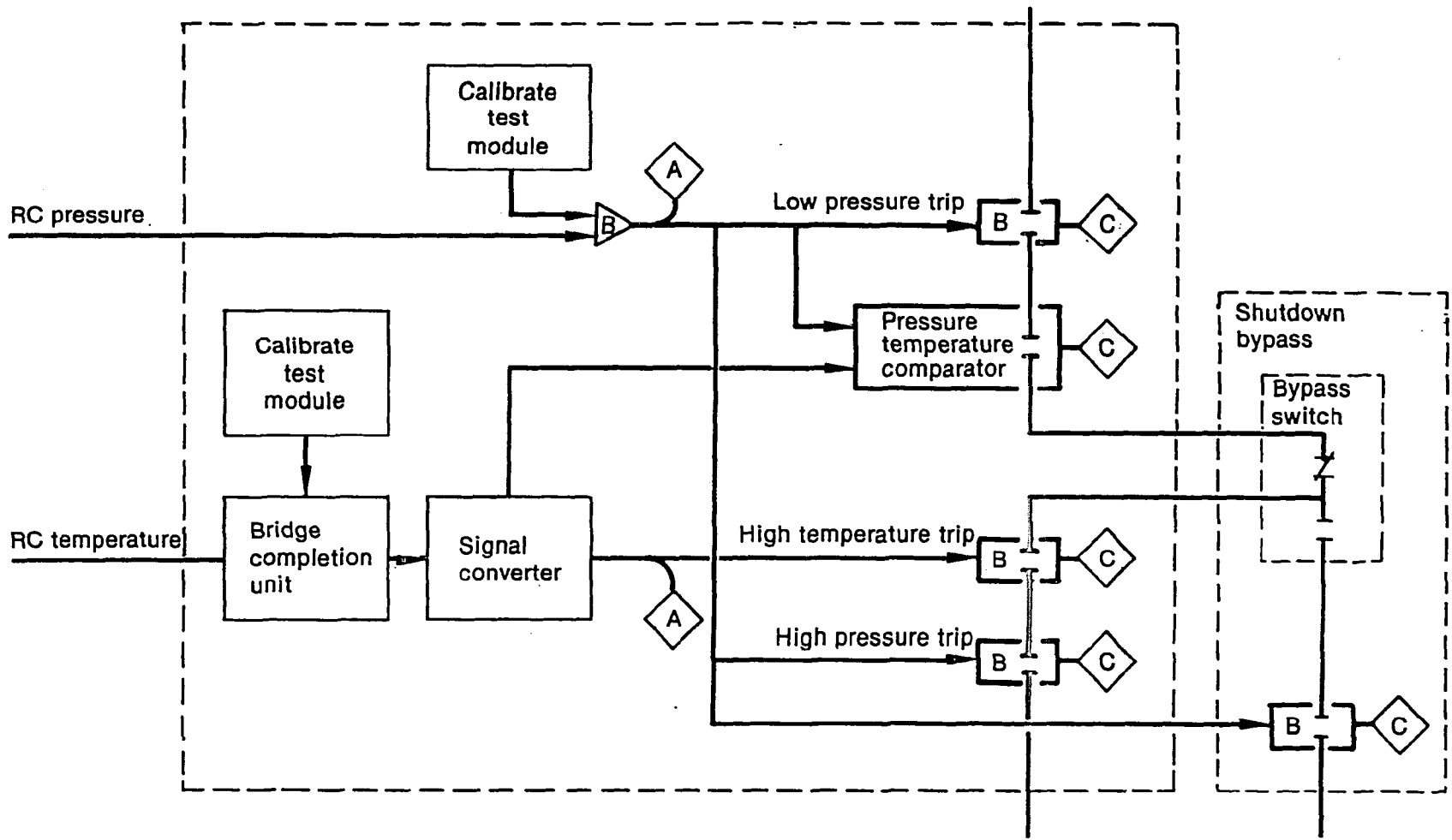

Figure 10. Reactor coolant temperature and pressure logic.

**Table 17. RPS pressure channel component input and output**

---

<u>Instrument Designation</u>	<u>Input</u>	<u>Output</u>
Pressure transmitter	1700 psig to 2500 psig	4 to 20 mA
Instrument power supply	Internal	24 Vdc
Buffer amplifier	2 to 10 Vdc	0 to 10 Vdc
Pressure test circuit	± 15 V internal	0 to 10 Vdc
High pressure bistable	0 to 10 Vdc	Channel trip
Press/temperature bistable	0 to 10 Vdc	Channel trip
Low pressure bistable	0 to 10 Vdc	Channel trip
Shutdown bypass bistable	0 to 10 Vdc	Channel trip
RP CH A -15 V power supply	1E power	+ 15 V
RP CH A + 15 V power supply	1E power	- 15 V

---

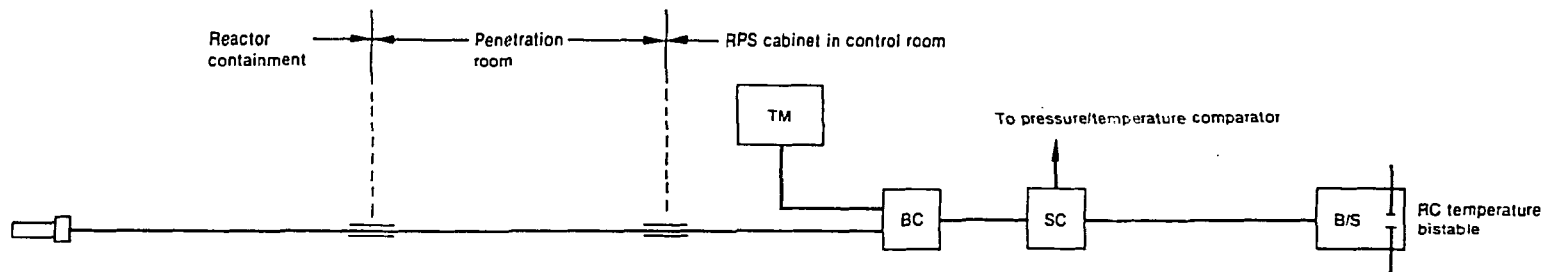

Component	Resistance temperature device	Reactor building cable	Reactor building penetration	Penetration room cable	Cable feedthrough	Test module	Bridge circuit	Signal conditioning	Cabinet wire and cable	Bistable (includes trip relay)	Comments on channel	
Environment Temperature	RC temperature = 600°F	120°F average, 130°F maximum		60 to 130°F		50 to 80°F ambient in control room						
Radiation	3 x 10 <sup>4</sup> RAD			1 x 10 <sup>6</sup> RAD		NA						
Interfaces	TAP in RC piping	None			110V power and module interlock							
EQ	40 y											
Testing	Comparing similar channels					Functional testing monthly, response time at 18 months and 18 months end-to-end check						
Calibration	Manufacturers' original calibration and 18 months					Monthly						
Maintenance	18 months or refueling											
Signal	204 to 224 OHMS change for 520 to 620°F						0-100 mA		± 10V dc		Normal or accident	
Physical data	Platinum sensing element			130 ft 1SPA16G.3								
Stressors	Temperature, radiation, moisture and EVV cycles						Maintenance, testing cycles, and operational trips					
Indicators of degradation	Resistance change, connector seats, signal, variance from other channels	Insulation resistance change, mechanical damage	Inert gas leak, contact corrosion, mechanical damage, insulation resistance change	Insulation resistance change, mechanical damage		Drift, failure			Loose connection	Drift, dirty contacts, failure		

Figure 11. RPS reactor coolant temperature channel with supporting aging and engineering data.

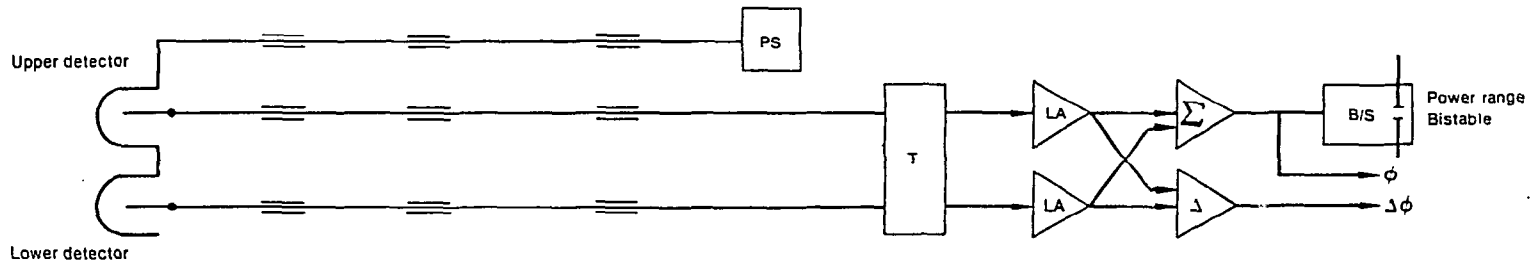

Component	Ion chambers	Interfaces at reactor and triax cable	Reactor building penetration (triax)	Penetration room cable (triax)	Cable feedthrough (triax)	Detector power supply	Power range test circuit	Linear amplifier	Summing and differential amplifier	Bistable (includes trip relay)	Comments
Environment Temperature	120°F average, 130°F maximum		60 to 130°F		50 to 80°F ambient in control room						
Radiation	3 x 10 <sup>4</sup> RAD		1 x 10 <sup>6</sup> RAD		NA						
Interfaces	None		110V power and module interlock								
EQ	40-y life										
Testing	18 months end-to-end check					Functional testing monthly, response time at 18 months and 18 months end-to-end check					
Calibration	Initial manufacturers' calibration					Monthly					
Maintenance	18 months or refueling										
Signal	10 <sup>-5</sup> to 10 <sup>-2</sup>					300/800 Vdc	10 <sup>-5</sup> to 10 <sup>-2</sup>		0 to +10 volts		
Physical data	Ion chamber										
Stressors	Thermal cycles, moisture	Temperature radiation, moisture				Electrical transients, operation and maintenance cycles, testing					
Indicators of degradation	Drift, signal variance from other channels	Insulation resistance change, mechanical damage				Electrolytic capacitor failure, drift		Drift, failure, cycle testing		Dirty contacts cycle testing	

6 2722

Figure 12. RPS power-range channel with supporting aging and engineering data.

**Power/Reactor Coolant Pumps Trip.** The RC pump power breakers are monitored to determine if they are closed. The opening of a single breaker initiates four independent signals, one to each protective channel. This information is received by a pump monitor logic, which counts the number of RC pumps in operation and identifies the coolant loop where the pumps are operating. The pump monitor logic output controls the trip point of a power/pump comparator and initiates a channel trip. The power signal ( $\phi$ ) is received from the power-range channel. The pump-power-monitor channel is shown in Figure 13.

**Reactor Coolant Flow Channel.** The RC flow transmitters for flow loop A and each of the RPS channels are tied into the flow-transmitter piping as shown in Figure 3. There is a similar arrangement for flow loop B. The flow channel is shown in Figure 14. The flow transmitters are pressure transmitters (previously discussed under sensors). A power/imbalance/flow ( $\phi/\Delta\phi/F$ ) comparator is included in each protection channel. Each comparator receives  $\phi$  and  $\Delta\phi$  inputs from a different power-range channel. The comparator bistable trips de-energize the channel-trip relay when

$$\phi > f(F) + f(\Delta\phi) \quad (1)$$

$$f(F) = KF \quad (2)$$

where K is the power/flow trip ratio and F is the total RC flow in percent full flow. The constant K is an adjustment and has a minimum range adjustment of 1.00 to 1.20.<sup>a</sup>

**Reactor Building Pressure.** Each protection channel continuously monitors the state of an independent, normally closed, reactor building pressure switch. Momentary change of a pressure switch to the open state initiates a trip of the associated protection channel. The reactor building high pressure trip locks in requiring manual reset. Contacts are provided and wired out to terminal boards to indicate a reactor building high pressure trip condition to the plant computer. The contacts open to indicate a trip condition.

a.  $\phi$  = Signal proportional to reactor power.

$\Delta\phi$  = Difference between the reactor flux in the top of the core versus the reactor flux in the bottom of the core.

The complete reactor building pressure-measurement channel is shown in Figure 15. The pressure-switch transmitter is located outside the reactor building in the penetration room where it is easily accessible for maintenance and calibration.

**Main Turbine and Main Feedwater Pumps A & B Trip.** The loss of the main turbine when the reactor is at greater than 20% power will trip the reactor. Likewise, the loss of both feedwater pumps with the reactor at greater than 20% power will trip the reactor. The loss of the main turbine is sensed by a pressure switch that opens on decreasing generator turbine electrohydraulic control (EHC) emergency trip supply pressure. The contact of this pressure switch (via a contact buffer) de-energizes the reactor-trip string. The loss of a feedwater pump is sensed by the combination of pressure switches that open on decrease of turbine control oil pressure and discharge pressure. The loss of both feed water pump A and B must be sensed before the reactor trip string will be de-energized. See Figure 16 for the block diagram of these channels and related aging information.

**System Testing.** The use of 2-out-of-4 logic between channels permits a channel to be tested on-line without initiating a reactor trip. Maintenance, to the extent of removing and replacing any module within a channel, may also be accomplished in the on-line state without a reactor trip.

To prevent either the on-line testing or maintenance features from creating a means for unintentionally negating protective action, the RTS is set for a 2-out-of-3 logic trip. Each channel also has a system of interlocks that initiates a channel trip when a module is placed in the test mode or is removed from the system to further prevent unintentional negating of protective action.

The test scheme for the RPS is based on the use of comparative measurements between like variables in the four channels, and the substitution of externally introduced digital and analog signals as required, together with measurements of actual protective-function trip points. A digital voltmeter is used to make accurate measurements of trip-point and analog-signal voltages. The test modules allow the operator to test the system channels from the input of any bistable, up to the final actuating device at any time during reactor operation. The bistable test consists of inserting an analog input from one of the channel test modules and varying the input until the bistable trip point is reached.

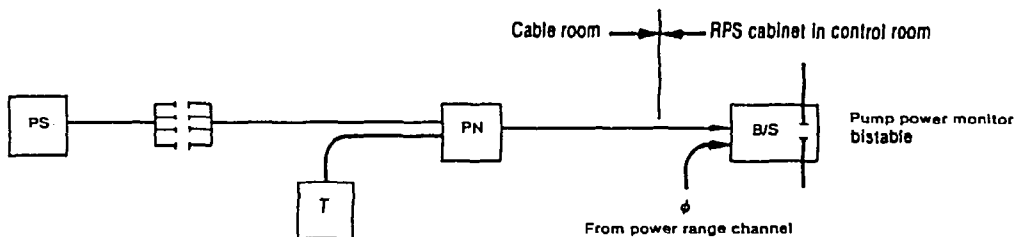

Component	Auxiliary power supply	Reactor coolant pump monitors	Test circuit	Count monitor	Cable and feedthrough	Bistable (with trip relay)	Comments
Environment Temperature	40 to 90°F maximum				50 to 80°F ambient in control room		
Radiation	NA						
Interfaces	110V power and module interlock						
EQ	40-y life						
Testing	Functional testing monthly, response time at 18 months and 18 months end-to-end check						
Calibration	Monthly						
Maintenance	18 month or refueling						
Signal	-15 to -300 Vdc	125 Vdc	Variable	0 to 10V ac		contact actuator	
Physical data		Contract monitor					
Stressors	Line transients, testing cycles, maintenance on/off switching						
Indicators of Degradation	Drift, electrolytic capacitor failure	Drift, failure, loose connections				Failure, loose connection, dirty contacts	

6 2723

Figure 13. RPS pump power-monitor channel with supporting aging and engineering data.

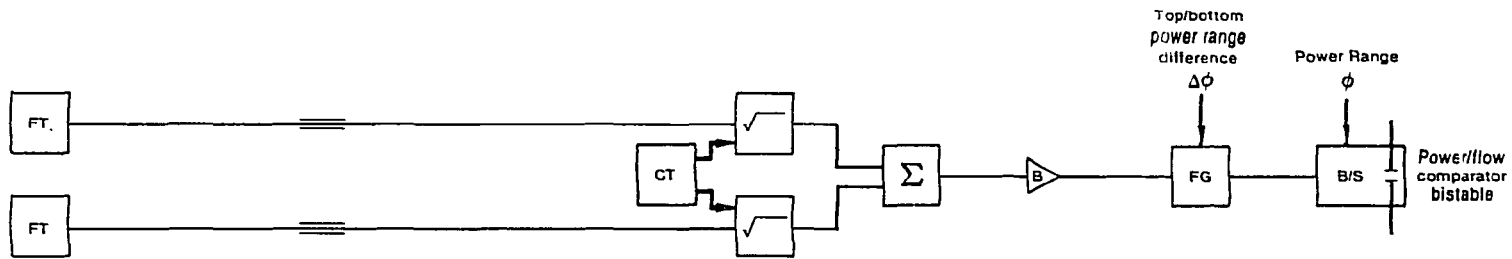

Component	Flow transmitter	Reactor building cable	Reactor building penetration	Penetration room cable	Calibrate/test module	Square root extractor	Summing circuit	Buffer amplifier	Function generator	Bistable includes trip relay	Comments	
Environment Temperature	120°F average, 130°F maximum		60 to 130°F		50 to 80°F ambient in control room							
Radiation	3 x 10 <sup>4</sup> RAD		1 x 10 <sup>6</sup> RAD		NA							
Interfaces	RC piping	None		110V power and module interlock								
EQ	10 y	40-y life										
Testing	Functional pressure testing and 18 months end to end check				Functional testing monthly, response time at 18 months and 18 months end-to-end check							
Calibration	18 months	NA		Monthly								
Maintenance	18 months	NA		18 months or relueling								
Signal	Pressure from flow element	4-20 mA current loops				± 10 Vdc						
Physical data				130 ft 1SPA 16G.3								
Stressors	Temperature, radiation, maintenance and installation handling, moisture, environmental cycles	Temperature, radiation, environmental cycles, moisture	Temperature, radiation, operational, environmental, and maintenance cycles, moisture	Maintenance, testing cycles, and operational trips								
Indicators of degradation	Dirt, moisture intrusion, wearout, failure, signal variance from similar channels	Insulation resistance change, mechanical damage	Inert gas leak, contact corrosion, mechanical damage, insulation resistance change	Insulation resistance change, mechanical damage	Drift, failure, loose connections, dirty contacts							

Figure 14. RPS reactor coolant flow channel with supporting aging and engineering data.

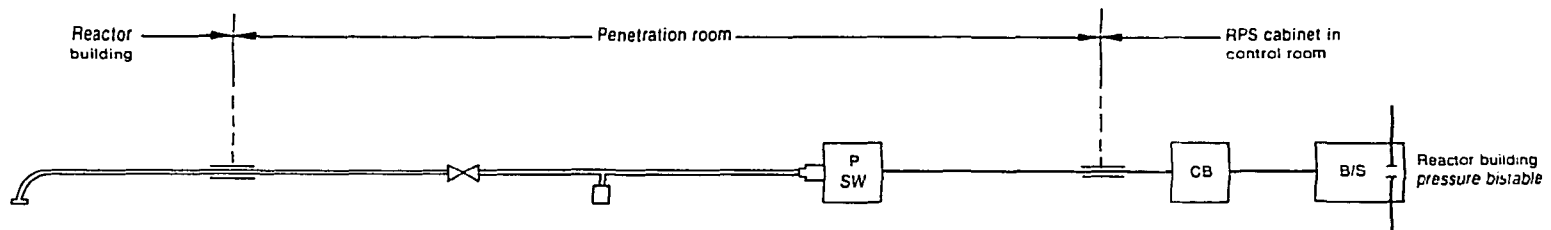

Component	Reactor building pressure sample tube	Reactor building penetration (tubing)	Tubing	Valve	Test tee	Pressure switch	Penetration room cable	Cable feedthrough	Contact buffer	Bistable (with trip relay)	Comments	
Environment Temperature	120°F average		60 to 130°F					50 to 60°F ambient in control room				
Radiation	3 x 10 <sup>4</sup> RAD		1 x 10 <sup>6</sup> RAD					NA				
Interfaces	RB pressure		NA		Test Pres	RB Pressure and ± 10 Vdc		110V power and module interlock				
EQ	NA		40-y life			10 y	40-y life					
Testing	NA		NA			Functional testing monthly, response time at 18 months and 18 months end-to-end check						
Calibration	NA		NA		Apply test pressure here	Monthly						
Maintenance	NA		NA			18 month or refueling						
Signal	0 to 10 PSI		0 to 10 PSI			0 to 10 PSI and ± 10 Vdc						
Physical data	Sample tube			Valve	Test tee	Contact closure	1SPA16G.3	No connector	Electronics			
Stressors	Moisture, maintenance cycles, testing cycles											
Indicators of degradation	Blocked tube, visual cracks, or corrosion					Drift, failure, contact, resistance change					Contact resistance, binding, failure, drift	

6 2727

Figure 15. RPS reactor building pressure-switch channel with supporting aging and engineering data.

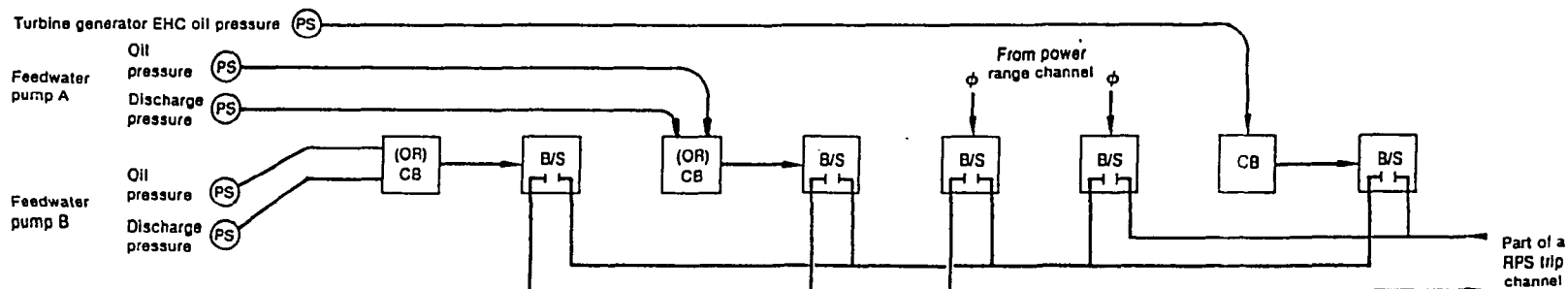

Component	FWP pressure switch	Turbine pressure switch	FWP A pressure contact buffer	Bistable (with trip relay)	FWP B pressure switch and contact buffer	Bistable (with trip relay)	Flux $\geq 20\%$ bistable and relay	Flux $\geq 20\%$ bistable and relay	Turbine pressure switch contact buffer	Bistable (with trip relay)	Comments
Environment Temperature			60 to 80°F in control room								
Radiation			NA								
Interfaces	Oil and feedwater	EHC oil	110V power and module interlock system								
EQ	10 y		40 y								
Testing	Monthly functional testing, response times every 18 months or refueling										
Calibration	18 months										
Maintenance	18 month or as required										
Signal	Oil 30 to 375 PSI Discharge Pressure 300/1000 PSI	300/1000 PSI	Contact closure and $\pm 10$ Vdc								
Physical data	Switch operated by pressure change		Electronic equipment located in cabinet								
Stressors	Temperature, vibration testing		Testing, operational transients, maintenance cycles								
Indicators of degradation	Increase in contact resistance, seal leak, failure		Drift, failure, loose connections for electronics, dirty contacts, failure or sticking for relays								

6 2725

Figure 16. RPS main feedwater pump and turbine trip block diagram with supporting aging and engineering data.

The value of the inserted test signal as monitored by both the system-analog indicator and the test-digital voltmeter represents the true value of the bistable trip point. Thus, the test verifies not only that the bistable functions, but that the trip point is correctly set.

During the test, satisfactory operation of the bistable can be observed by watching the *trip-status* light in the reactor trip module.

The reactor trip module 2-out-of-4 logic and the associated control rod drive breaker are tested by pressing various combinations of two logic test switches in the reactor-trip module to simulate the six combinations of trips inherent in a 2-out-of-4 coincidence logic. During the test, satisfactory performance of the trip-logic relays can be observed by watching the *trip-logic-relay* lights and the *breaker-trip* lights on the reactor-trip module. This test verifies not only all the combinations of 2-out-of-4 logic, but also that the trip-logic relays and the control rod drive breakers will trip.

On-line testing may be performed at different intervals and levels within the system, consistent with satisfactory system-reliability characteristics. The reliability of the system for random failures has been ensured by careful selection of components, failure-testing logic elements, environmental testing the system modules, and long-term prototype proof-testing.

The system test scheme includes frequent visual checks and comparisons within the system on a regular schedule (in which all channels are checked at one time). Less-frequent electrical tests are also done on a rotational plan, in which the tests are conducted on different channels at different times.

#### **RPS Periodic Testing Required by NUREG-0103 Rev. 4**

##### ***Analog Channels***

1. Monthly functional test comprised of injecting simulated signals into the channel to verify proper operation and correct alarm trip set points.
2. A channel calibration at least every 18 months or at refueling.
3. A response-time test every  $n \times 18$  months on a staggered basis where  $n$  is the number of channels.
4. Channel operations check every shift.

##### ***Reactor-Trip Module and Control Rod Drive Breaker and Associated Logic***

1. Monthly functional test to check the 2-out-of-4 logic by pressing various combinations of two logic test switches in the reactor-trip module to simulate the six combinations of trips inherent in the 2-out-of-4 coincident logic.
2. A response-time test every 18 months.

**Summary and Conclusions from RTS Detail Study.** The functional description of the RTS and system-test schemes provides insight as to how the RTS works. Minimum test requirements are found in the technical specifications (NUREG-0103, Revision 4). However, the actual number of tests exceed the minimum because of additional verification and maintenance tests. The NPE provided information on the number of events for measurement-channel components, subcomponents, and cause. But, as discussed previously, the degradation due to testing is not apparent from these data. The testing scheme used compares like variables in the four channels and signal substitution. Also, test modules allow the operator to test system channels at any time during operation.

Component failure analysis should show a distinction between failures which are in a direction to cause a trip (safe direction) and those in a direction that prevents a trip (nonsafe direction). If aging related failures tend to increase false trips, rather than prevent trips, this information would be important in addressing the consequences of aging. A failure mode and effects analysis for component failures would be required to fully assess the aging impact.

After years of operation, events caused by design errors are reduced significantly. Improved test and maintenance procedures have also reduced events caused by design error. However, obsolescence of sensors and equipment often require redesign of new components for replacement. Many of the problems are with relays and breakers. Improved maintenance practices (which includes quarterly refurbishing of breakers) has reduced problems in that category. Common-mode events are experienced in practice that are not found in data banks. For example, a leaking valve shorts out a RTD or a roof leak affects a penetration. Few RTS system outages occur due to a component failure because the affected channel is repaired under high priority; the redundant channels continue to perform the

safety-protection function while repairs are made. Most RTS system outages are due to common-mode failures that take two or more channels out.

The one-line diagrams provide an end-to-end picture for each of the RTS measurement channels, along with all the pertinent information of interest related to aging. This includes environmental data, interfaces, Equipment Qualification (EQ), testing frequency, calibration and maintenance, signal levels, stressors, and indicators of degradation for each component in the channel. Because regulatory requirements are the same for all these channels, they are covered in a later section of this report.

## ESFAS Description for a B&W Plant

In the B&W plant, the ESFAS system is part of the Engineered Safeguards Protective System (ESPS) and is designed to function under accident conditions to prevent, or reduce, the severity of a Loss-of-Coolant Accident (LOCA). When the reactor coolant is lost during an accident, the ESPS acts to provide emergency cooling and ensure structural integrity of the core, maintain the integrity of the reactor building, and collect and filter any potential reactor building penetration leakage.

The ESFAS, or actuating portion of the ESPS, is the I&C part of the system, which includes the sensor channels, analog modules, and the logic subsystem. The Unit Control (UC) module in the logic subsystem provides the output-actuating signal to the various actuated systems. There is one UC module for every item (pump, valve, etc.) controlled by the protective channel. A protective channel's UC modules are connected in parallel with the output of the coincidence logic (e.g., one channel may signal four valves or pumps simultaneously). The output of the coincidence logic follows a normally closed path in each UC module, finally terminating in an output relay with each module.

The generic ESFAS diagram for a representative B&W plant is shown in Figure 17 (Reference 9). Figure 17 illustrates the interconnections between major ESFAS subsystems. The three blocks on the left side of Figure 17 are identical analog subsystems that receive pressure-transducer inputs. The output lines from the analog subsystems go to the two identical center logic subsystems where the 2-out-of-3 logic decides whether an ESF system is actuated. On the right side of the figure are the five

ESF actuated systems. The actuated systems are not discussed in this report.

**Instrumentation.** Three types of measurement channels provide signal input to the ESFAS. These are building pressure, building pressure switches, and RC pressure. The reactor building pressure transmitters provide input for initiation of reactor building isolation, high pressure injection, low pressure injection, and reactor building cooling. The pressure switches provide input signals of high reactor building pressure for initiation of reactor building spray. The RC pressure signal is utilized for low pressure alarm and interlock to decay heat removal return flow valves. Three independent measurement channels are provided for each of these three process parameters. Figure 2(a. and b.) are representative of the input instrumentation channels.

**Reactor Coolant Pressure Transmitters.** There are three identical independent RC wide-range pressure transmitters, one for each analog channel. These transmitters have an input of 0 to 2500 psig and an output of 4 to 20 mA. They are located inside the reactor building on the second level.

**Reactor Building Pressure Transmitters.** There are three identical independent reactor building narrow-range pressure transmitters, one for each analog channel. These transmitters have an input range of -15 to +15 psig, and an output of 4 to 20 mA. They are located inside the east and west penetration rooms mounted on the reactor building wall.

**Pressure Switches.** There are six identical independent reactor building pressure switches, two for each analog channel. The pressure switches have a set point range of 0 to 20 psig. They are located inside the east and west penetration rooms, mounted on the reactor building wall.

**ESPS Pressure Channel Event Data.** The NPE listed events for B&W systems ESFAS pressure channels are presented in Table 18. From the subcomponent menu, the items having the most problems were transmitters/signal converters, bistables, sensing lines, and moving internal parts. The four leading causes were design error, setpoint drift, failures, and operator/maintenance error. The two leading effects were component inoperable (failed), and component performance degraded.

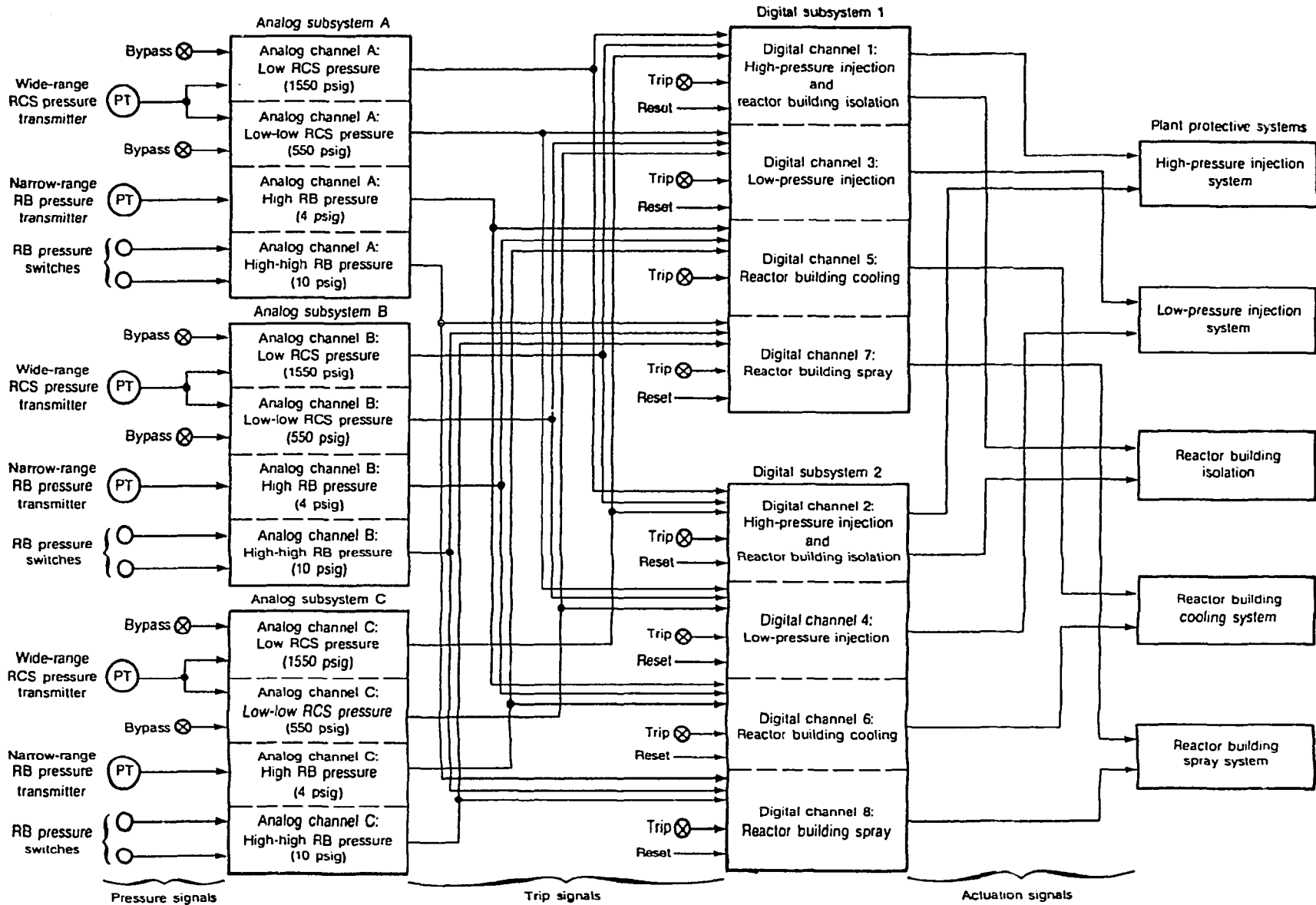

Figure 17. Engineered safeguards system.

**Table 18. ESPS pressure channel events**

---

<u>(06) Subcomponent Selection Menu</u>		<u>Percent<sup>a</sup></u>
3	Moving internal	11
24	External support/mounting	2
50	Drive/operator/actuator	2
72	Bistable/switch/mag amp	22
88	Power supply/amplifier	4
94	Sensor	4
95	Circuit component	7
96	Transmitter/signal converter	29
97	Sensing line/instrument piping	16
 <u>(07) Cause Selection Menu</u>		
1	Fouling/clogging/blockage	2
3 <sup>b</sup>	Corrosion	7
12	Moisture/condensation	9
14	Environmental effects	2
17 <sup>b</sup>	Thermal cycling/expansion	2
18 <sup>b</sup>	Vibration/impingement	4
21	Foreign material	2
23 <sup>b</sup>	Mech wear/galling/scoring	2
36 <sup>b</sup>	Short/ground/arcing	4
40 <sup>b</sup>	Setpoint drift/calibration	15
46 <sup>b</sup>	Local I&C failure	13
60	Operator/maintenance error	11
65	Design, construction error	17
98	Cause—other	2
99	Cause—unknown	7
 <u>(08) Effects Selection Menu</u>		
70	Reactor/turbine/generator trip	3
71	Safeguards actuation	6
73	USNRC fine/sanction	6
83	Component tripped/inoperable	56
84	Component performance degraded	15
87	Equipment mispositioned/misaligned	3
88	Conditions out of spec	6
91	Leak	3
98	Effect—other	3

---

a. Percent based on 27 articles.

b. Aging-related cause.

---

**Analog and Digital Logic Subsystems.** The analog subsystem includes instrument power supplies, test circuits, signal amplifiers, comparators, and logic modules as shown in Figure 18 (which is one of three identical analog subsystems). Likewise, Figure 19 is one of the two logic subsystems. Symbols used in Figures 18 and 19 are shown in Figure 20.

The three analog subsystems and two logic subsystems are located in seven cabinets in the control room. They are supplied power from vital busses *A*, *B*, and *C*. These cabinets contain all the logic necessary (and the modules that make up the logic systems) to determine when and what safeguard actions should be initiated.

**One-line Diagrams for Actuation Signals.** The aging-related data with the diagrams is similar to that discussed with the RTS, so only a brief discussion is given here which includes differences or changes.

**High Pressure Injection.** The simplified one-line diagram for initiation of the High Pressure Injection (HPI) systems (channels 1 and 2) is shown in Figure 21, along with related aging data for the various components. The pressure transmitter and reactor building cable and piping arrangement is identical to that of the RPS reactor coolant pressure channel. The low pressure injection (LPI) system (channels 3 and 4) is identical to the HPI channel.

**Reactor Building (RB) Cooling and Isolation.** Channels 5 and 6 initiate the RB cooling and isolation function from RB pressure transmitters as shown in Figure 22.

**RB Spray-Activation Channel.** The RB-spray activation Channels 7 and 8 are shown in Figure 23.

## System Operation

**Normal Mode.** When the unit is up and RC pressure and building pressure are stable, there is essentially nothing that the engineered safety-control system does other than provide some analog information. It provides a wide range RC pressure signal to a recorder in the control room and three RC pressure analog signals to the com-

puter. It also provides three RB analog pressure signals to the computer. Some engineered safety devices, such as HPI pumps and building cooling units have normal functions as well as emergency functions.

**Emergency Operation.** Emergency operation under accident conditions is the whole purpose of the Engineered Safeguards (ES) systems. In the case of a LOCA, the ES system would actuate in the following manner. First, the three wide range RC pressure transmitters will indicate a drop in pressure. These signals are fed to their respective buffer amplifier which provides a 0 to 10 Vdc signal to the trip bistables and the inhibit (bypass) bistables. When the RC pressure drops to 1550 psig, the corresponding signal from the buffer amp to the bistables is 6.200 Vdc. The HPI trip bistable is set to trip at that voltage. The output signal from the trip bistable goes to the logic buffer. From here, the signal fans out to two isolated contact outputs that provide signals to two redundant logic channels in the digital subsystems, in this case the two HPI channels. These channels are redundant (or equivalent) but not identical in their final action devices.

The trip-logic module is the first module in the digital channel to receive the signal from the analog channels. As soon as it receives two or more signals, it provides a signal to each UC module in its channel. The UC module provides the last contact in the ES control cabinets to actuate the final-action device. In this case, that would be the HPI pumps and the associated HPI valves.

In addition to the main task of transmitting the trip signal to the final-action units, several auxiliary functions are performed by the digital subsystem. The implementation of these auxiliary functions is, in fact, the sole reason for the existence of the digital subsystem.

The digital subsystem functions are:

1. Combine the trip signals from the analog subsystems and initiate a trip to the final-action units when any two of the three analog subsystems call for actuation of the trip system
2. Provide a latch or sealing feature in the advent of a 2-out-of-3 trip, which ensures an output trip signal until operator intervention cancels it. The operator can cancel or reset the trip only after the trip-initiating conditions have disappeared from the system

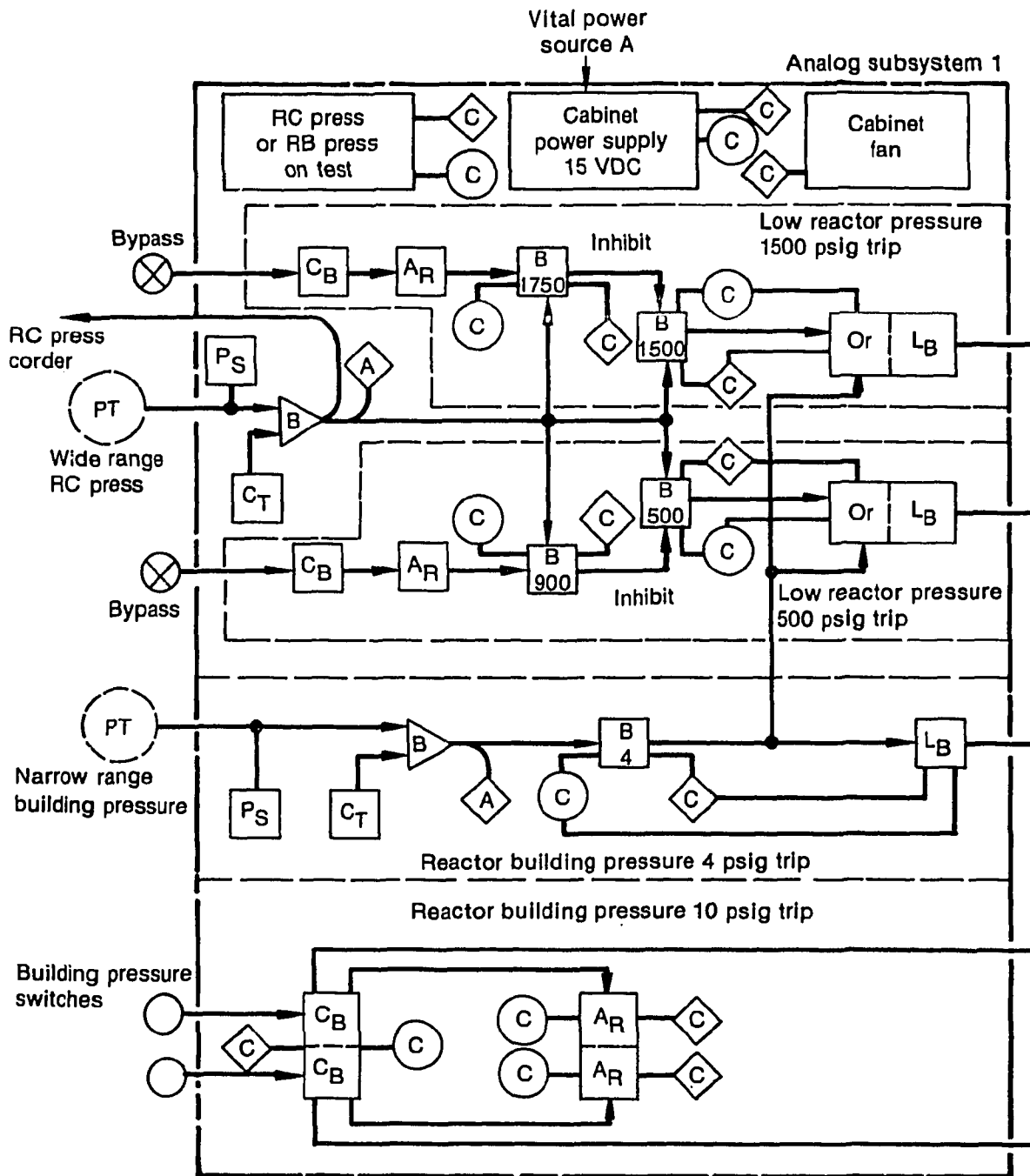

6 11 041



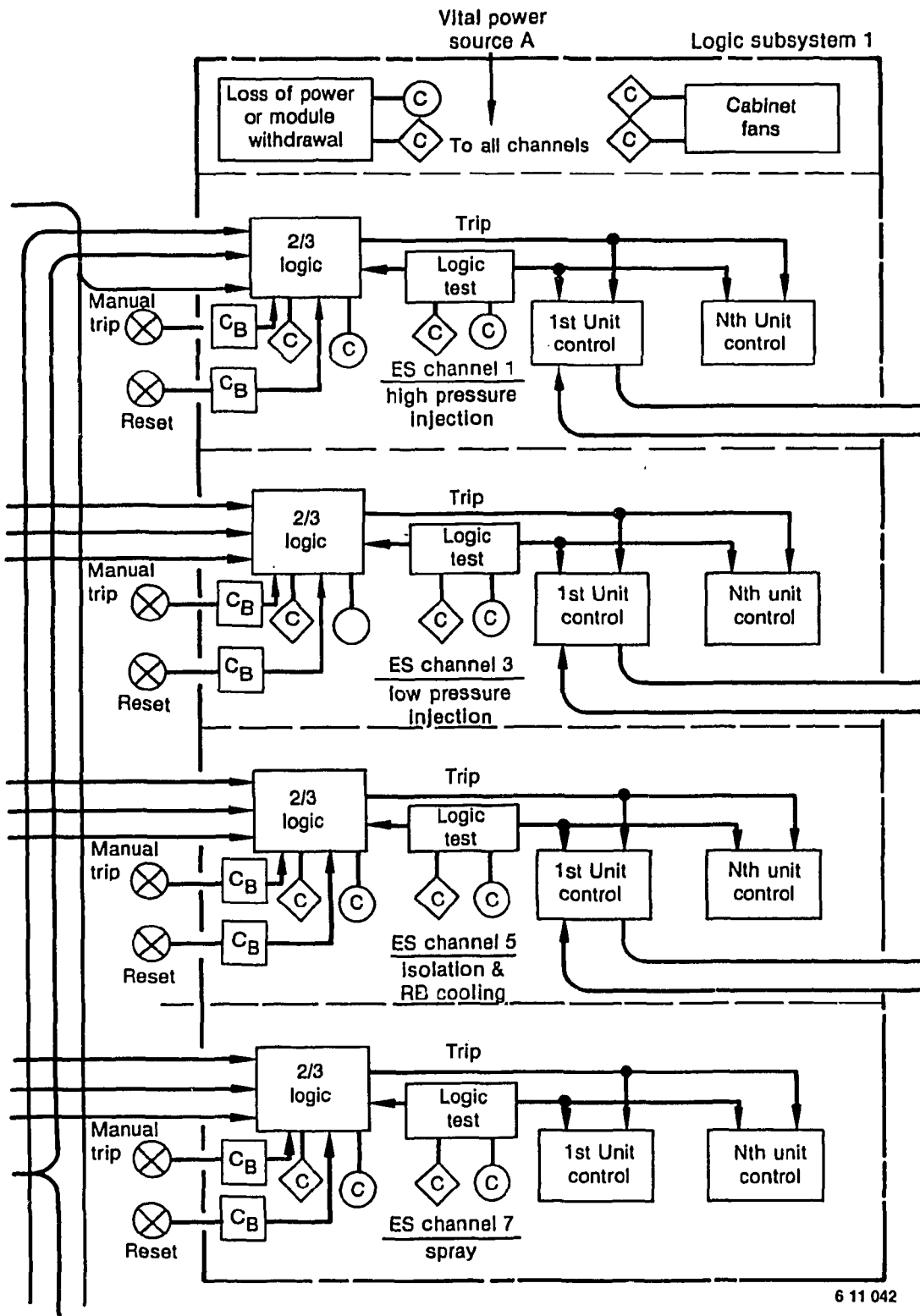









Figure 18. Analog subsystem.



6 11 042

Figure 19. Logic subsystem.

Legend

	-----	Logic buffer
	-----	Contact buffer
	-----	Callibrate test
	-----	Momentary switch
	-----	Bistable
	-----	Auxiliary relay
	-----	Limit switch
	-----	Computer monitored contacts
	-----	Computer monitored analog signal
	-----	Buffer (isolation amplifier)
	-----	Sensor power supply
	-----	Annunciator contacts

6 0788

Figure 20. Symbols used in Figures 18 and 19.

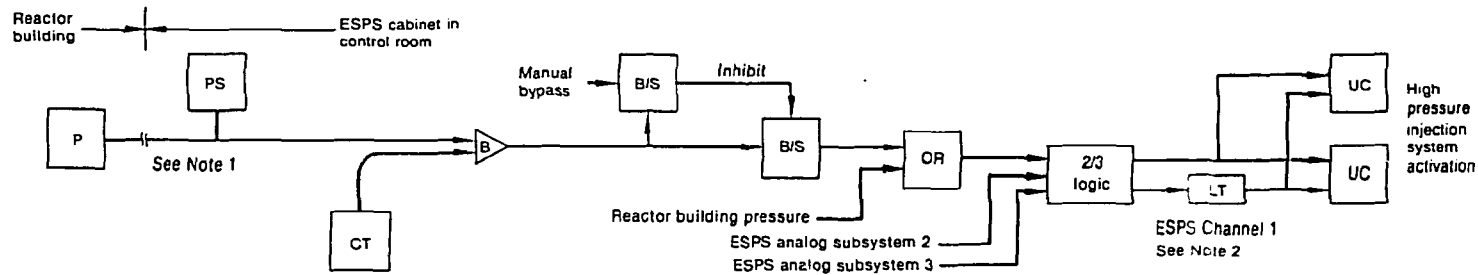

Component	Reactor coolant pressure transmitter	Instrument power supply	Calibrate test	Buffer amplifier	Bistable	Bistable	OR logic	2/3 logic	Logic test	Unit control	Comments
Environment Temperature	120°F average	50 to 80°F									
Radiation	3 x 10 <sup>4</sup> RAD	NA									
Interfaces	Pressure TAP	110V power and module interlock									
EQ	10-y life	40 y									
Testing	Monthly Functional test, response time test at 18 months										
Calibration	18 months or refueling	18 months									
Maintenance		18 months									
Signal	0 to 2000 psi	4 to 20 mA	0 to 10 Vdc								
Physical data											
Stressors	See Note 1										
Indicators of degradation	Drift, moisture intrusion, wearout, failure, signal variance from similar channels	Drift, failure, contact resistance change, binding or bent parts									

Note 1: The transmitter, cable, reactor building penetration, terminal strip and connectors are identical to that of the RPS RC pressure channel

Note 2: The low pressure injection is identical.

8-0066

Figure 21. ESPS channel for initiating the HPI with related aging and engineering data.

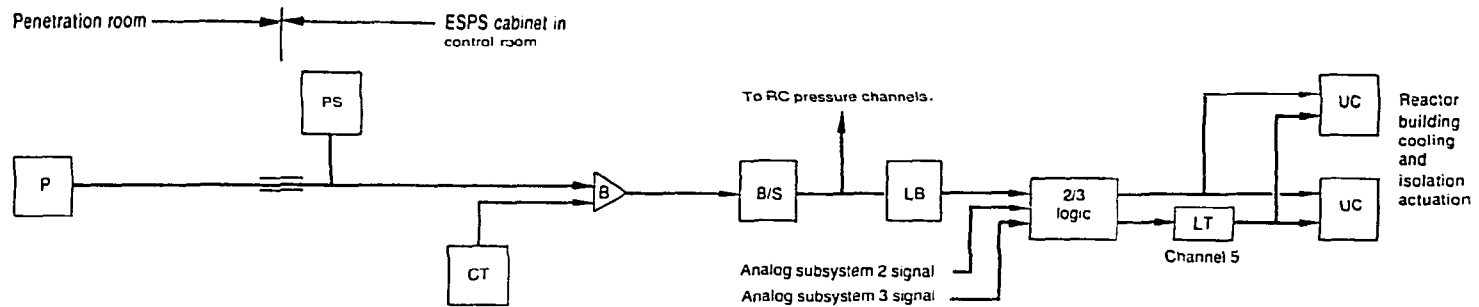

Component	RB Pressure transmitter	Penetration room cable	Instrument power supply	Circuit test	Buffer amplifier	Bistable	Logic buffer	2/3 logic	Logic test	Unit control	Comments	
Environment Temperature	60 to 130°F		50 to 80°F									
Radiation	1 x 10 <sup>6</sup> RAD		NA									
Interfaces	RB pressure						110V power and module interlock					
EQ	10 y	40 y										
Testing	Monthly functional test, response time test at 18 months											
Calibration	18 months											
Maintenance	18 months											
Signal	RB pressure in 4 to mA out			4 to 20 mA		± 10 Vdc						
Physical data												
Stressors	Moisture, maintenance cycles, testing cycles											
Indicators of degradation	Drift, moisture, intrusion, wearout, failure, signal, variance from similar channels	Insulation resistance change, mechanical damage	Electrolytic capacitor failure, drift	Drift, failure, contact resistance change, binding or bent parts								

Figure 22. ESPS channel for initiating the RB cooling and isolation with related aging and engineering data.

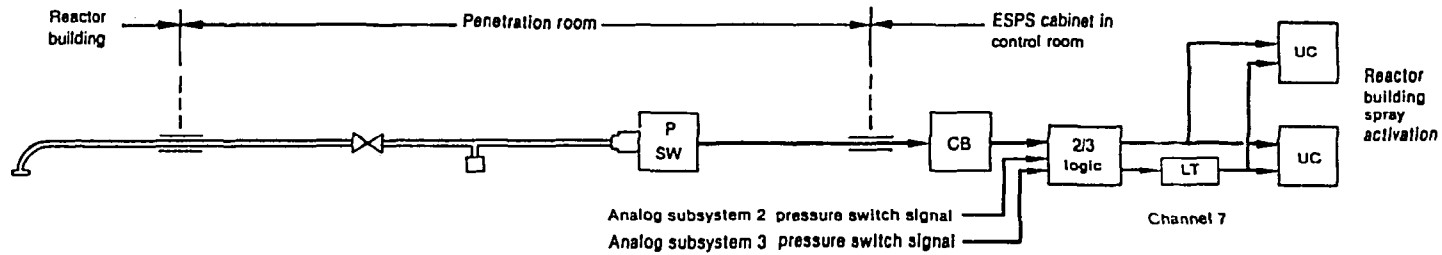

Component	Reactor building pressure sample tube	Reactor building penetration (tubing)	Tubing	Valve	Test tee	Pressure switch	Penetration room cable	Contact buffer	2/3 logic	Logic Test	Unit control	Comments
Environment Temperature	120°F average	60 to 130°F					50 to 80°F					
Radiation	3 x 10 <sup>4</sup> RAD	1 x 10 <sup>6</sup> RAD					NA					
Interfaces	RB pressure	NA	Test pressure	RB pressure and ± 10Vdc			110 power and module Interlock					
EQ	NA	40-y life			10 y	40 y						
Testing	NA	NA			Monthly functional test, response time test at 18 months							
Calibration	NA	NA			Apply test pressure here	18 months						
Maintenance	NA	NA			18 months							
Signal	0 to 10 PSI	0 to 10 PSI			0 to 10 PSI	± 10 Vdc						
Physical data	Sample tube	Valve		Test tee	Contact closure							
Stressors						Moisture, maintenance cycles, testing cycles						
Indicators of degradation	Blocked tube					Drift, failure, contact resistance change, binding or bent parts						

6 2728

Figure 23. ESPS channel for initiating RB spray with related aging and engineering data.

3. In the event of a LOCA, allow the operator complete maneuverability by enabling him/her to inhibit or energize, (individually), any of the final-action units to meet the requirements of the immediate situation
4. Provide the operator with a reliable means of manually tripping a channel
5. Provide for complete on-line testing of each component, including the final-action unit itself, without causing a false trip or inhibiting a valid trip during the test interval.

If the HPI channels fail to maintain RC pressure and it continues to decrease, then at 600 psig the core-flooding system will automatically dump water into the core. This will happen automatically, with no means for manual control. If the RC pressure continues to drop, at 550 psig the LPI channels (3 and 4) will be actuated in the same manner as the HPI channels. Anytime there is a large RC leak or rupture, the coolant will flash to steam as it escapes from the system, causing the building pressure to increase. The building pressure is monitored by three narrow-range building pressure transmitters, with an output 4 to 20 mA. As in the RC pressure channels, these signals are fed to their respective buffer amplifier. The 0 to 10 Vdc output signal of the buffer amplifier is then fed to the building pressure trip bistable.

When the building pressure increases to 3.0 psig (6.000 Vdc), the bistable trips. The bistable output signal is then fed to its respective logic buffer and through OR gate logic. It is also fed back to the HPI and LPI logic buffers. With this circuit, the building pressure channel will not only activate the building cooling and isolation channels (5 and 6) but will go back and pick up the high (1 and 2) and low (3 and 4) pressure injection channels, assuming they have not already been picked by the RC channels. Channels 5 and 6 are actuated in the same way that channels 1 through 4 are activated, with the only difference being the number of UC modules and the type of final-action devices. If the building pressure continues to increase, at 10 psig the RB spray will be activated. The building spray system uses six pressure switches in a double, 2-out-of-3 logic. Three are used with channel 7 and three with channel 8. Each pressure-switch signal is fed to a contact buffer before going on to the digital channels. With the double 2-out-of-3 logic, channels 7 and 8 will activate as soon as the first two pressure switches asso-

ciated with each channel trip. Channels 7 and 8 are the only digital channels that will not receive an analog-trip signal if there is a loss of power to the analog cabinets.

**Periodic Testing.** Periodic on-line tests are performed on the system while the unit is running. These tests are performed monthly to ensure the operability of this system and each individual device. The testing must begin in the digital channels and end in the analog channels. This sequence allows testing for failures that could initiate safety action prematurely.

These tests include such things as comparing the values of the analog variables between channels and observing that the equipment status is normal. These tests are designed to detect the majority of failures that might occur in the analog portions of the system, as well as the self-annunciating type of failure in the actuation portions of the system. The electrical tests are designed to detect failures that are not self-evident or self-annunciating and are detectable only by testing, such as low voltage levels on power supplies or drift.

**Digital-Channel Testing.** Each actuation channel (2-out-of-3 logic and its associated UC modules, etc.) has a rotary test switch and 10 test-indicator lamps. A given actuation channel is tested by advancing the test switch through its positions, while noting that in each position the *nine on and one off* lamp pattern is maintained. If this lamp pattern is lost in any given position of the test switch, the channel has failed that test. If the channel fails a test, the test-switch position is not to be changed until the trouble source is located and corrected, then the test may be continued. The switch (a continuously rotating type) is advanced until it returns to the *operate* position.

A specific position of the test switch enables the manual control switch to be used for testing. When the individual safeguards devices are tested, the test switch is advanced to this position—noting that the lamp test is passed in each intervening position. The safeguards devices are then tested through the operation of the manual switches, after which the test switch is advanced to the *operate* position—noting that the lamp test is passed in each intervening position.

**Analog-Channel Testing.** The use of 2-out-of-3 logic between analog channels permits these channels to be tested on-line without a safeguards system trip. Maintenance to the extent of removing

and replacing any module within a channel may also be accomplished without a safeguards system trip. To prevent the on-line testing or maintenance features from creating a means of unintentionally negating safety action, a system of interlocks initiates trip signals into the affected 2-out-of-3 logic whenever an analog module is placed in the test mode or is removed from the system.

The test scheme for the safeguards system is based on the use of comparative measurements between like variables in the three analog subsystems and the substitution of analog signals as required. The test circuits allow the technician to test bistable operation at any time during reactor operation. The bistable test consists of inserting an analog input from one of the pressure test modules and varying the input until the bistable trip point is reached. The inserted test signal (as monitored by both the system analog indicator and a test voltmeter connected to the appropriate test points) represents the true value of the bistable trip point. Thus, the test verifies not only that the bistable functions, but also that the trip point is properly set.

During the test, satisfactory operation of the bistable can be observed by watching the trip status light on the bistable module, and the subsystem trip lamp on the logic buffer module.

The set points of the pressure switches may be checked by connecting a source of pressure and a pressure gauge to the pressure-transmitter connections provided inside the RB. This check may be made, regardless of reactor power, when access to the building is attained. The design provides access for this check at all reactor power levels.

#### ***Testing Required by Technical Specification.***

The ESPS periodic testing required by NUREG-O103 Revision 4 (technical specification)<sup>10</sup> is:

1. A functional test to be performed monthly on a staggered basis, with each train or automatic actuation logic tested at least every 62 days.
2. Response time of each ESFAS function shall be demonstrated to be within the limit at least once every 18 months.

**Summary and Conclusions for the ESFAS Detailed Study.** The detailed study has provided information about how ESFAS operates and initiates the various engineered safety features. Redundancy of channels allows on-line testing and

maintenance. The technical specifications provide minimum test requirements. However, actual tests exceed the minimum because of additional verification and maintenance testing. After maintenance, the system or component repaired is also tested before returning to service.

The one-line diagrams provide an end-to-end picture of the components necessary for one safety system to be energized, along with the related information and engineering data supporting the aging study. These figures are themselves a good summary of all the environmental factors and indicators of degradation for each of the components in the channels.

All sensor problems for ESFAS would be associated with pressure measurements because only pressure channels are used on these B&W ESFAS systems for initiating events.

The subcomponents (other than sensors) most often having problems are breakers—followed by bistables, switches, and power supplies. Causes for ESPS events (other than sensors) are most often listed as arcing/grounding, followed by components sticking, and other mechanical disabilities. About 47% of the ESPS events were aging related as identified in the causes given in Table 18.

## **Essential Auxiliary Systems and Interfaces**

The third objective of this study is to identify the Essential Auxiliary Support systems (EAS) for the RPS.

The EAS are those systems that must function to ensure that the capability of the RPS will be able to perform safety functions. Systems included in the EAS are:

1. Heating, ventilating, and air conditioning (HVAC)
2. Electrical power systems (Class 1E power).

The effect of the loss of HVAC on the RPS electronics would depend on the particular design, ambient temperature, and other factors. The loss of air conditioning may result in a temperature rise in the RPS cabinets, but the effects on the system are uncertain.

The loss of Class 1E power would trip the affected part of the system. Both RTS and ESFAS have built-in interlock systems that would trip a channel in which a module is removed. In addition, manual control provides trip and reset capability during operation, testing, and maintenance.

The electrical ground is also an integral part of these systems. Control-room-monitor readouts and computer-recording systems have direct interface with both RTS and ESFAS. Safe shutdown systems are interfaced with the reactor control systems. The RTS and ESFAS should perform its function of accident mitigation whether reactor control is from the control room or safe shutdown facility.

Direct interface with the RTS and ESFAS is through input sensors, output controlled devices or systems, Class 1E power system, control readouts including computers, and manual controls. The HVAC would interface indirectly through environmental control.

The essential auxiliary systems and interfaces have only been identified here and will be explored further in Phase 2 of the RPS study.



## REGULATORY ISSUES RELATING TO RPS

### Design Requirements and Guidelines

The design requirements for RPS are the same as the Class 1E I&C safety system. Table 19 summarizes these various requirements and guidelines. For older plants which were constructed in the early 1970s, the guiding document was IEEE 279-1971.<sup>11</sup> The criteria of IEEE 279-1971 addresses considerations such as design bases, redundancy, single failures, qualification bypass, status indication, and testing. The general acceptance criteria are found in 10 CFR 50 [50.55a(h)] and the general design criteria of Appendix A to 10 CFR 50.<sup>12</sup> The general design criteria that apply to the RPS are listed in Table 19. Regulatory guides that provide additional guidance on the RPS are also given in Table 19. For applications to construct or operate nuclear plants, Chapter 7 of the Standard Review Plan (SRP) provides guidance for USNRC staff reviewers in performing safety reviews on RPS. The TMI action plan requirements that apply to the RPS are also given in Table 19.

### Issues Related to Design

**Setpoint Drift in Instrumentation.** This issue was originally identified in Appendix D of NUREG-0572.<sup>13</sup> The LER data collected over a 3-year period for years 1976, 1977, and 1978 showed that 10% of all LERs were related to drift in the set points of an instrument beyond technical specification limits. The possible solution proposed in NUREG-0572 was to repair, recalibrate, and restore instruments to service if drift was due to component failure. If drift was due to inherent instrument inaccuracies, then increase the margin between the selected set point and technical specification limits.

The LER review for only I&C data for the RTS for years 1976 to 1981 indicated the percentage of events due to drift was 28.2% for BWR and 54.1% for PWR. The higher percentage here is because only those LERs related to I&C were considered. Data from NPE for the period from 1975 to July 1985 showed the percentage of problems on RPS due to drift as the cause at 6% to 10%.

The trend appears to be toward fewer drift problems, but it is still a problem for original equipment with inherent drift problems. As this older equip-

ment is updated and replaced with improved designs, the drift problem will diminish. For example, the original equipment might have called for a one-turn potentiometer. When the one-turn potentiometer was replaced with a multiturn potentiometer, the problem was solved because of better adjustment resolution.

**Electronic Equipment Lifetime.** Some electronic equipment has useful lifetimes of less than 40 years, as demonstrated by experience. Guidelines for specifying definitive lifetimes for this equipment and design contingencies are necessary. Obsolescence is a related problem where vendors no longer support a particular piece of equipment, such as sensors. Residual life assessment is also a related problem. How do you assess residual life?

**Equipment Qualification Requirements.** For older plants, electrical equipment qualification was required under IE Bulletin 79-01B and is addressed in the utilities response to IEB 79-01B.<sup>14</sup> In addition, the requirements of 10 CFR 50.49 are applicable for all replacement equipment within the scope of the equipment qualification program purchased after February 22, 1983. Section 10 CFR 50.49(1) endorses IEEE-323-1974 and states that "Replacement equipment must be qualified in accordance with the provisions of this section<sup>15</sup> unless there are sound reasons to the contrary." Seismic qualification of IE equipment is found in IEEE 344-1975.<sup>16</sup> The equipment qualification requirements are also summarized in Table 19.

Guidelines are needed for requalifying equipment for lifetimes greater than 40 years and requalifying equipment based on actual environments. Environmental qualification does not ensure the performance integrity after many years of operation. For example, insulation resistance would change with time and synergistic influences of aging or degradation of interfaces could affect performance.

**Maintenance Requirements.** Currently, the USNRC regulatory approach to nuclear plant maintenance concentrates on quality assurance and surveillance requirements. Quality assurance is applied to design, construction, and operation for structures, systems, and components important to safety (10 CFR 50 Appendix B). Surveillance requirements are found in 10 CFR 50.36. These maintenance requirements apply only to safety-related systems. The SRP provides guidance for

**Table 19. RPS regulatory requirements and guidelines**

Criteria	Title	Applicability		Remarks
		RTS	ESFAS	
Part 1	Design	—	—	—
1. 10 CFR 50				
a. 50.55a(h)	Criteria for Protection Systems for Nuclear Power Generating Stations (IEEE Std. 279)	R <sup>a</sup>	R	Basic criteria for older plants.
2. General Design Criteria (GDC), Appendix A to 10 CFR 50				
a. GDC 2	Design Bases for Protection Against Natural Phenomena	R	R	—
b. GDC 4	Environmental and Missile Design Bases	R	R	—
c. GDC 13	Instrumentation and Control	R	R	—
d. GDC 19	Control Room	R	R	—
e. GDC 20	Protection System Functions	R	R	—
f. GDC 21	Protection Systems Reliability and Testability	R	R	—
g. GDC 22	Protection System Independence	R	R	—
h. GDC 23	Protection System Failure Modes	R	R	—
i. GDC 24	Separation of Protection and Control Systems	R	R	—
j. GDC 25	Protection System Requirements for Reactivity Control Malfunctions	R	—	—
k. GDC 29	Protection Against Anticipated Operational Occurrences	R	R	—
3. Regulatory Guides (RG)				
a. RG 1.22	Periodic Testing of Protection System Actuation Functions	G <sup>b</sup>	G	May be extended to include response time.
b. RG 1.47	Bypassed and Inoperable Status Indication for Nuclear Power Plant Safety Systems	G	G	—

**Table 19. (continued)**

Criteria	Title	Applicability		Remarks
		RTS	ESFAS	
c. RG 1.53	Application of the Single-Failure Criterion to Nuclear Power Plant Protection Systems	G	G	—
d. RG 1.62	Manual Initiation of Protection Actions	G	G	—
e. RG 1.75	Physical Independence of Electric Systems	G	G	—
f. RG 1.105	Instrument Spans and Set Points	G	G	Aging should be taken into account.
g. RG 1.118	Periodic Testing of Electric Power and Protection Systems	G	G	May require updating to take into account NSSS user groups studies on increasing surveillance intervals.
<b>4. Branch Technical Positions (BTP) ICSB</b>				
a. BTP ICSB 12	Protection System Trip Point Changes for Operation with Reactor Coolant Pumps Out of Service	G	G	—
b. BTP ICSB 21	Guidance for Application of Regulatory Guide 1.47	G	G	—
c. BTP ICSB 22	Guidance for Application of Regulatory Guide 1.22	G	G	—
d. BTP ICSB 26	Requirements for Reactor Protection System Anticipatory Trips	G	—	—
<b>5. TMI Action Plan Requirements for I&amp;C Systems (RPS) Important to Safety</b>				See NUREGs for details. <sup>c</sup>
Item II.K.2.10	Safety-grade anticipatory trip	R	—	— <sup>c</sup>
Item II.K.3.10	Proposed anticipatory trip modification	R	—	— <sup>c</sup>
Item II.K.3.12	Anticipatory reactor trip	R	—	— <sup>c</sup>
<b>6. IEEE Standards</b>				
a. 279-1971	Criteria for Protection System for Nuclear Power Generating Stations	R	R	—

**Table 19. (continued)**

Criteria	Title	Applicability		Remarks
		RTS	ESFAS	
b. 379-1977	Application of the Single Failure Criteria to NPGS Class 1E Systems	R	R	—
c. 317-1972	Electric Penetration Assemblies in Containment Structures for Nuclear Power Generating Stations	G	G	—
d. 383-1974	IEEE Standard for Type Test of Class 1E Electric Cables, Field Splices, and Connectors for Nuclear Power Generating Stations. The Institute of Electrical and Electronics Engineers, 1974	G	G	—
<b>Part 2</b>	<b>Electrical Equipment Qualification</b>			
1. IE Bulletin 79-01B	—	R	R	—
2. 10 CFR 50.49	—	R	R	All replacement equipment purchased after 2/22/83.
3. IEEE-323-1974	General Guide for Qualifying Class 1E Electrical Equipment for Nuclear Power Generating Stations (1971)	R	R	All replacement equipment purchased after 2/22/83.
4. IEEE 344-1975	Recommended Practices For Seismic Qualification Of Class 1E Electrical Equipment For Nuclear Power Generating Stations	R	R	Seismic qualification.
5. RG 1.131	Qualification tests of electrical cables, field splices, and connections for light water-cooled Nuclear Power Plants	G	G	Covers cables and splices.
<b>Part 3</b>	<b>Testing Requirements</b>			
1. Plant FSAR Sections 7.1.1.6, 7.1.2.3.4, 7.1.3.3.4	—	R	R	—
2. Standard Technical Specification Sections 3/4.3.1, 3/4.3.2	Standard Technical Specifications for Babcock and Wilcox pressurized water reactors-NUREG-0403 Rev. 4, Fall 1980	R	R	—
3. IEEE-Std 338-1977	Criteria for Periodic Testing of Nuclear Power Generating Station Safety Systems	R	R	Could have a stronger statement on indicators of aging.

**Table 19. (continued)**

Criteria	Title	Applicability		Remarks
		RTS	ESFAS	
4. Regulatory Guide 1.68	Initial Test Programs for Water-Cooled Nuclear Power Plants	R	R	—
Regulatory Guide 1.118	Periodic Testing for Electric Power and Protection Systems	R	R	—
Regulatory Guide 22	Periodic Testing of Protection System Actuating Systems	R	R	—

a. R = required.

b. G = guideline.

c. NUREG-0718, "Licensing Requirements for Pending Applications for Construction Permits and Manufacturing License;" NUREG-0737, "Clarification of TMI Action Plan Requirements;" and NUREG-0694, "TMI-Related Requirements for New Operating Licenses."

reviewing maintenance data<sup>17</sup> and IEEE-338 calls for corrective action such as maintenance after a failed test.<sup>18</sup>

The Standard Review Plan (SRP) covering Equipment Qualification of mild environment equipment includes as one of the review items a minimum 18 month review of maintenance program data. Other key phrases in the USNRC SRP are a *good preventive maintenance program* and *well supported maintenance program*. IEEE Std. 338-1977 which covers the criteria for periodic testing calls for corrective action such as maintenance or repair following a failed test and before the successful completion of a repeat test. This reference to maintenance in IEEE Std. 338-1977 is the strongest reference to maintenance. Maintenance is an issue that warrants further study to determine the extent necessary to require enhanced maintenance.

### Testing Requirements for Monitoring Functional Indicators

One of the objectives of this study was to review testing requirements for functional indicators. The primary requirements for testing RPS are found in the plant Final Safety Analysis Report (FSAR), plant technical specifications, and IEEE Std 338-1977. Regulatory Guides 1.68,<sup>19</sup> 1.118,<sup>20</sup> and 1.22<sup>21</sup> give general

requirements for initial test programs and periodic testing acceptable to the USNRC staff, which coordinate with IEEE Std. 338-1977.

The FSAR (Reference 22) Sections 7.1.1.6, 7.1.2.3.4, and 7.1.3.3.4 cover general testing requirements; functional indicators are not mentioned.

The standard technical specifications, Sections 3/4.3.1 and 3/4.3.2, cover the ESPS and RPS testing requirements for B&W plants. To meet these requirements, the instrumentation channel is demonstrated operable by performing channel checks, calibration, and functional tests. Minimum surveillance requirements are also specified. Response times and set points are required to be recorded by technical specifications; other functional indicators are not. The technical specifications for the other NSSS vendors are similar (References 23 to 25). Preventive maintenance performed by utilities may have measurement parameters recorded from which functional indicators could be obtained. However, this is not a technical specification requirement.

IEEE Std. 338-1977 covers the criteria for periodic testing of all safety systems. On page 8, Section 4 of the standard, the following recommendation (rather than requirement) is stated:

"... the testing program should provide trend data and the capability to observe degradation and an indication of incipient failures."

No further mention of trend data or indicators is found in the standard. On page 10, Section 6, Item 8 of the standard, the following statement is made:

“Results of a failed test cannot be negated by a simple successful repetition. A successful repetition of the test shall be preceded by evaluation or corrective action such as maintenance, repair, or changes to procedures.”

Regulatory Guide 1.118 Section C7 states *the ability to detect significant changes in failure rates should be considered in the selection of initial test intervals*. The word *should* makes this a recommendation, not a requirement. When a methodology for arriving at an optimum test frequency for RTS and ESFAS is developed, Regulatory Guide 1.118 will probably be revised.

Most of the tests demonstrate operability and are of a *go-no-go* type. When limits are exceeded, the standard requires corrective action, such as maintenance, to correct the problem. Thus, trend data that could be collected would be a trend within the *go-no go* limits, or on corrective action performed.

The surveillance testing performed in the nuclear plants will detect some degraded performance parameters not directly measured, but incipient failures may not be detected. For example, corrosion on contacts or connections that has not yet fully degraded the system may not be detected.

**Adequacy/Inadequacy of the Current RPS Testing Program.** The fifth objective of this study is to assess the adequacy or inadequacy of the current testing program, based on the findings in this report. Four aspects of the current testing program are of concern in assessing the adequacy of the program. These are: (a) testing frequency, (b) type of data collected, (c) testing relationship to preventive maintenance, and (d) response time testing.

**Test Frequency.** At the present time, the NSSS users groups are either in the process of reviewing the RTS test frequency requirements or have recently completed their studies. This review by the users' groups was initiated in late 1983 in response to the USNRC generic letter 83-28,<sup>26</sup> *Required Actions Based on Generic Implications of Salem ATWS Events*, and recommendations in NUREG-1024, *Technical Specifications - Enhancing the Safety Impact*.<sup>27</sup> Among the primary objectives of this activity was the reduction of unnecessary tran-

sients and challenges to safety systems caused by testing, and the time expended by the utility operating staffs in performing and documenting the various surveillance activities. The general feeling of utilities has been that the RTS equipment was being degraded by too frequent testing (i.e., being worn out by testing). In addition, frequent periodic testing of systems, with no compensating reduction in risk to the public, results in unnecessary economic costs and, in some cases, excessive exposure of plant personnel, which may be adverse to safety.

The optimum test interval for a particular RPS would depend not only on a reliability analysis, but also on maintenance and other technical merits. As a minimum, this would require an analysis of the RPS for each of the NSSS vendors and include such items as allowable out-of-service times, maintenance, and channel redundancy. Such a study is beyond the scope of this present task. A recent study<sup>28</sup> has indicated that the relationships of surveillance, equipment operation, failure mechanism, and maintenance are complex. Testing may identify component degradation; if CM rectifies the problem before impairment of function, then the component's lifetime can be extended. However, if degradation due to all causes occurs over a long period of time compared to the surveillance interval, the usefulness of testing to identify degradation is diminished. Also, if PM is performed fairly often with proper treatment of performance indicators, increasing surveillance intervals will have little impact on failure rates. Thus, the general consensus is that testing intervals may be lengthened without adversely affecting safety, providing trending of performance parameters and functional indicators are carried out. Whether the increase in test interval is from monthly to quarterly (or some other reasonable time period) is dependent not only on the reliability study, but also on any changes in technical specifications on allowable out-of-service times.

**Data Requirements for Aging Studies.** The generic data bases are limited primarily to failure data. The aging research needs more trend data. Present test requirements are not providing the trend data needed. For example, the required tests are designed to demonstrate that equipment is functioning according to design requirements and they appear to be fully adequate for this purpose provided they are carried out as recommended in IEEE standards. However, if establishing trends relative to equipment aging is the goal, then condition monitoring should be considered. Continuous

or periodic monitoring of key analog parameters over a long period of time is the solution. One approach would be to establish a baseline for the key parameters; deviations from this baseline would be an indication of degradation. Most utilities already monitor many of the key parameters by computer for control purposes. An additional software program for periodic sampling, data storage, and long-term trending analysis may not be unreasonable. Where this is not feasible, measurements taken during refueling might be an alternative.

The whole issue of data bases requires further study not only for RPS, but also for all NPAR studies.

**Maintenance.** Performing PM periodically to correct deficiencies before they result in failure reduces the importance of testing for detecting degradation and failures. After performing maintenance, the units worked on are tested to ensure function. Thus, where PM is routine, it includes periodic testing. Testing and maintenance should be coordinated to minimize excessive testing. One maintenance study (Reference 29) indicated that only about 25% of equipment troubles are of a type that can be prevented by detection of degradation in a component by testing. In addition, the role of equipment qualification, obsolescence, spare parts, and operating schedules must be factored into the maintenance program along with surveillance testing, repairs, and allowable down time. A good maintenance program almost makes aging a nonproblem on redundant systems such as the RPS because the periodic rejuvenation does not allow the system to grow old.

**Response-Time Testing.** Channel response times are checked at least once every 18 months, with some being checked as frequently as monthly. This is primarily an electronic and relay/breaker response test. Sensor response should also be considered because of possible aging effects in sensors, which would change their response time over months of operation in harsh environments.

**Conclusions About Current Testing Program.** Conclusions reached about the current testing program are:

1. The current testing requirements in technical specifications may need revision to allow for any recommended increase in surveillance test intervals based on NSSS vendor (and others) reliability studies.
2. The right kind of data needs to be collected and baseline data bases established by utilities to better support aging and life-extension goals. For example, the key parameters at strategic locations already monitored by the utility could also be used for trending of voltage and current signatures.
3. A review of the data collected should be such that significant changes in failure rates are detectable. An accelerated drift rate or an increase in failure rate of a component should be detected.
4. Maintenance and testing quality and quantity must be coordinated to minimize redundant testing
5. Response time of sensors should not be overlooked, if the response time to a process is an important safety factor.
6. In general, surveillance testing exercises the protection channel logic and verifies signal processing system calibrations and bistable setpoints. Response time for scram breakers are also measured. The surveillance testing may detect degraded performance parameters not directly measured, but incipient failures might not be detected. For example, corrosion on switch contacts which have not yet reached the point of degrading system performance. Thus, surveillance testing is a thorough exercise of the RPS and may detect problems related to significant degradation due to aging, but incipient stages of aging probably wouldn't be determined.

## Cables in Containment

Part of the RPS that is in the containment includes cables, penetrations, sensors, and connectors. In addition, there are power cables (and other nonsafety cables) that may be in radiation zones and difficult to reach. The material in the passive components experience ambient temperature and low radiation for long periods, but still must withstand a transient with high radiation and temperature under accident conditions. In these environments, complicating material response factors, such as synergisms, sequential responses, and sensitizations may become important. It is unknown (a) whether or not cable degradation can be determined from external NDE electrical measurements and tests, and (b) what portion of this degradation is

attributed to aging. Cables are not mentioned in the SRP Chapter 7 as an item to be reviewed.

Further research is needed on cables to resolve outstanding issues. Specific items include:

1. Baseline data requirements on operating history of cables in the containment (i.e., temperature, humidity, and radiation).
2. Indicators of cable degradation from visual inspection, mechanical, and electrical tests.
3. What electrical measurements by nondestructive examination will provide indications of degradation? (Candidates are insulation resistance, loss factor, and dielectric constant)
4. Are cable end samples for mechanical tests of hardness, elongation, and brittleness sufficient?
5. Criteria are needed for connectors and feedthrough in order to determine whether or not they should be replaced.
6. Cable replacement criteria need to be established.

## Life Extension

For life extension, the design requirements and guidelines still apply. The following issues, which are of a generic nature, also apply (they may apply to all systems and components, not just RPS):

1. Establishing baseline plant records for maintenance, including condition monitoring for trend analysis
2. Aging indicators and obsolescence
3. Spare parts
4. Nonsafety systems effect on safety systems.

The remarks column of Table 19 has comments from this preliminary review regarding which of the criteria and guides may require changes in order to address relicensing issues.

## Conclusions from Review of Regulatory Issues

The utilization of research results in the regulatory process includes updating standards as indi-

cated in the detailed discussion of the regulatory issues and are summarized here:

1. No requirements for monitoring functional indicators were found in plant FSARs, plant technical specifications, IEEE standard 338-1977, or Regulatory Guides 1.68, 1.118, and 1.22. Functional indicators are desirable for aging studies and in determining life-extension periods.
2. Chapter 7 of the SRP covers all the initial design and licensing issues necessary to receive a construction permit or operating license. Most of the regulatory guides dealt with items, such as single-failure criterion, physical and electrical independence redundancy, fail-safe designs, testability, and safety. A new section or revision may be needed to address life extension issues when identified.
3. Regulatory Guide 1.22 should be extended to include response time of sensors.
4. Regulatory Guide 1.118 should include an update on periodic testing requirements of the RPS based on research results.
5. Regulatory Guide 105 discusses drift. However, drifts should be reviewed again to be sure set points are adequately set and aging is taken into account. Drifts are still listed as a high percentage of causes of faults.
6. Guidelines are needed for requalifying equipment for lifetimes greater than 40 years and requalifying equipment based on actual environments.
7. Maintenance is an issue that warrants further study to determine the extent necessary to require enhanced maintenance.
8. The issue of data bases requires further study not only for RPS, but for all NPAR and life extension requirements.
9. RPS testing intervals may be extended from one month to quarterly or other reasonable time period. However, allowable out of service time and technical specifications changes would be required for plants which have not already done so.
10. Further research is needed to resolve outstanding issues on cables in containment.

## NPAR PRODUCTS FOR THE RPS

One of the objectives of this study was to satisfy the NPAR product list for each system studied. The comprehensive list of questions to be answered are addressed in this section. Because the RTS and ESFAS are quite similar (with regard to the aging phenomena) the results presented apply to both; collectively referred to as the RPS.

### Product Number 1—Preliminary Identification of Susceptibility of Materials to Aging

The aging processes occur in every RPS component from the time of manufacture of the components elementary materials to the end of its useful life. Both equipment qualification and the years of operating history on some of the older nuclear plants have provided information on the aging process and materials most susceptible to degradation. Because equipment within the containment is subject to severe environmental conditions and is least accessible for repair, it has received considerable attention in aging studies. All Class 1E safety-system components located within the reactor containment now have specified qualification periods after which they must be replaced. This qualification period is based on the life of the *weak* material in the component.<sup>30</sup> These weak link materials and components were identified in the detailed study section covering the sensors and cables in the RB and are listed on the one-line diagrams. The materials most often identified are electrical insulating materials and seal materials. The insulation and seal materials tend to degrade due to the environmental stressors acting over a period of time. Electronic-component failures due to seals and insulation degradation also occur. However, electronic-component failures are more often listed as random. This is probably due to the large numbers of electronic components used, their relatively low cost, and the fact that they seldom have a failure analysis performed on them. A summary of the weak link materials in the containment components is given in Table 20. All the materials listed have the potential for significant thermal aging. The basis for radiation susceptibility is listed as *allowable* or *threshold*. *Allowable* is defined as the level of radiation that can be received before significant degradation occurs. *Threshold* is the level of radiation at which detectable damage occurs.

The thermal aging process in insulating materials is complex and the mechanisms vary with different materials and under different service conditions. In general, exclusion of moisture and dirt, the presence of inert ambient atmosphere, limitation of mechanical stress, and freedom from vibration or thermal shock will tend to increase the life of insulating materials. However, thermal degradation is accelerated as temperature is increased. For many insulating materials the life is an exponential function of the reciprocal of the absolute temperature over a limited range of temperature. For thermal plastic materials or those which lose strength at elevated temperatures the softening point rather than the thermal stability may limit the temperature capability.

The materials subject to mechanical wear or active aging (passive aging is time dependent) include the metal contacts in relays, switches, and breakers as well as other working parts. This type of aging is dependent on demand or frequency of use instead of time.

### Product Number 2—Stressors and Related Environmental Factors Causing Aging Degradation

The stressors and environmental factors can be classified into three categories: environmental, operational, and maintenance-related. Important examples of each are as follows:

#### Environmental

1. Storage temperature (average and cycles)
2. Operating temperature (average and cycles)
3. Humidity (0 to 100%)
4. Radiation (total integrated dose)
5. Vibration and seismic.

#### Operational

1. Process fluctuations
2. Electrical transients
3. Power-supply variations
4. Switch transients.

**Table 20. Reactor protection system component materials in containment susceptible to aging**

<u>Material<sup>a</sup></u>	<u>Radiation Susceptibility</u>		<u>Equipment Where Material is Used</u>
	<u>Rads Gamma</u>	<u>Basis</u>	
Polyethylene	10 <sup>7</sup>	Allowable	Instrument and coaxial cable
Neoprene	10 <sup>7</sup>	Allowable	Instrument and coaxial cable
PVC	—	—	Coaxial cable
Polyolefin	—	—	Electrical penetrations
Elastomer	10 <sup>6</sup>	Threshold	Electrical penetrations
Dow Corning Sylgard	—	—	Electrical penetrations
Polysulfone	10 <sup>7</sup>	Allowable	Connectors and electrical penetrations
Ethylene Propylene	3 x 10 <sup>8</sup>	Allowable	Pressure transmitters
Silicon Oil	—	—	Pressure transmitters
Epoxy Glass Laminate CKT Board	10 <sup>6</sup>	Threshold	Pressure transmitters
Phenolic	10 <sup>6</sup>	Threshold	Electrical penetrations

a. The typical containment environment consists of the following stressors: (a) normal radiation expected is  $3 \times 10^4$  rads during the 40 year life. Design basis accident radiation is  $6.1 \times 10^3$  rads, (b) maximum operating temperature is 130°F, (c) relative humidity range is 10-100%, and (d) vibration will be assessed on a case by case basis, depending on location. These parameters apply to all the materials listed.

**Maintenance-Related**

1. Power on/off
2. Handling connectors and cables
3. Calibration and testing
4. Board replacement.

Only 4.75% of the RTS and 6.75% of the ESFAS failures (for all NSSS vendors) reported in NPE are identified as caused by environmental factors (ther-

mal, vibration, or moisture). However, environmental stressors contribute to many other cause categories such as erosion, fouling, and component failure. The operational and maintenance-related stressors also contribute to many of the cause categories, but are difficult to quantify from the NPE or LER data bases. Demand-related events categorized in the LER data base would be another example of degradation due to operational transients with a large portion of these due to testing.

## Product Number 3—Failure Modes Experienced During Operation and Their Causes

Mode is defined as the manner or method of failure, such as opening of a circuit due to corrosion or the seizure of a bearing due to wear. The actual physical cause of failure or wear is defined as the mechanism of failure. The leading causes of failure, when both LER and NPE data are taken into account (in the order of most frequent occurrence) are drift, piece-part failure, operator, maintenance, and testing error, mechanical malfunction, electrical failure, and design errors.

Table 21 presents the RPS failure modes and causes observed during the review of all the data sources. The actual cause for component failure is only sometimes given, because the piece part is often discarded at the plant without a detailed failure analysis. The causes listed in Table 21 are a summary of those reported and may not include all possible causes.

## Product Number 4—Functional Performance Indicators

The objective here is to identify functional indicators of degradation that may occur during plant life. Most of the indicators are flags that require further investigation to verify that the component is degraded. Many of the indicators could be caused by factors other than component degradation. Engineering or trend analysis using the various available indicators, along with additional tests or improved quality of tests, will often be required to determine the root cause of the observation.

Many components have catastrophic failures and there are no indicators before failure. Electronic components are a good example; a large portion of the RTS/ESFAS systems is composed of electronic components.

The review of operating experience solely from the various data bases does not readily reveal indicators of degradation on RTS or ESFAS. The reported events are for a given point in time; additional information is needed to establish a trend. The reported events indicate the *what*, *when*, and *where* about an event, but seldom provide actual measured values. Such values are obtained from measurements sometimes referred to as condition monitoring.

Condition monitoring is defined as a continuous or periodic measurement to obtain signatures or profiles in the time domain. Examples would be measurements of voltage, current, noise, and insulation resistance. Such measurements could provide the predictive information needed to establish trends. Trends that indicate a change in existing conditions could be an indicator of degradation.

However, if a data base can be sorted to present failures of some component or system over a period of time (months or years), a failure rate may be established. This would be an indicator of degradation of that type of component over time, which could be a generic problem.

Some trends may be established from plant test and calibration records, which contain *as-found* and *as-left* conditions. During tests and calibrations, any abnormal voltage, current, or response time may be an indication of component degradation.

Visual inspection of equipment may reveal such indicators of degradation as bent linkages, dirty contacts, misaligned contacts, or wear.

An indicator of degradation may be any observed change from expected measured parameters during tests and calibration. An abnormal observation from visual inspection or plant operations may also be an indicator. The following are examples of indicators.

Indicators from routine tests and calibrations:

1. Abnormal voltages
2. Abnormal currents
3. Abnormal response times
4. Abnormal resistance
5. Abnormal frequency
6. Abnormal vibration
7. Abnormal drift.

Indicators from visual inspection:

1. Mechanical misalignment or bent parts
2. Wear of linkages or contacts
3. Eroded or corroded parts
4. Discoloration or excessive arcing
5. Dirty contacts or excessive carbon.

Indicators from operations or historical record:

1. Abnormal readings from comparisons of like parameters, such as readings too high, too low, or erratic
2. Abnormal stressors, such as transients, lightning, high temperatures above limits or cycles

**Table 21. RPS failure modes during operations and cause**

Failure Mode	Cause
<i>System</i>	
RTS failed to trip when situation calls for trip (system failure)	1. Limits set too high due to procedure error or personnel error
RTS trips when process situation is normal	<ol style="list-style-type: none"> <li>1. Common-mode failure affecting two channels (power failure, flow reads low and computer constant error)</li> <li>2. Personnel error during testing or maintenance</li> <li>3. Flow transmitter fails low and ICS increases flow on low indication when actual flow is correct and reactor trip on high pressure</li> </ol>
Reactor shutdown due to two RTS channels down for repair	1. Technical specification requires reactor shutdown to fix problem. (Actual problem not specified)
Reactor shutdown due to common-mode failure effecting RTS	1. Sample-line valve leaked on RTS electronic component and shorted out RTS channel
<i>Channel</i>	
RTS channel fails to trip	<ol style="list-style-type: none"> <li>1. Component failure</li> <li>2. Limits set too high due to procedure error</li> <li>3. Testing or maintenance personnel error</li> <li>4. Procedure error</li> </ol>
RTS channel trips when not called for	<ol style="list-style-type: none"> <li>1. Personnel error</li> <li>2. Component failed</li> <li>3. Leaking valve drips water on RTD cable</li> <li>4. Procedure error</li> <li>5. Sensor failed</li> </ol>
<i>Systems Degradation and Electronic Component Failure</i>	
Pressure measurement channel bypassed due to component failure	<ol style="list-style-type: none"> <li>1. Transmitter out of tolerance (drift)</li> <li>2. Transmitter has erroneous reading (failed)</li> <li>3. Valve failure</li> </ol>

**Table 21. (continued)**

Failure Mode	Cause
Temperature measurement channel bypassed due to component failure	4. Electrical ground problem
	5. Leaking fitting
	1. Bistable failure
	2. RTD failed low (aging related)
	3. Bridge circuit failed
	4. Out of calibration
Pressure switch channel bypassed due to switch failure	5. RTD failed due to normal wear (aging)
	6. Failed amplifier
	1. Set point too high
	2. Will not open
	3. Calibration
Flow measurement channel bypassed due to component failure	4. Fails to operate
	1. Transmitter amplifier fails
	2. Seal failure on transmitter
	3. Valve packing leak in transmitter piping
	4. Transmitter failure
RC pump monitor out of limits	5. Electronic-component failure
	1. Personnel error
Power-range channel bypassed for component failure	1. Bistable fails
	2. Ion chamber fails due to erratic readings
	3. Out of calibration
	4. Procedure error
	5. Amplifier failed
	6. Power supply failed

**Table 21. (continued)**

Failure Mode	Cause
Power-supply failure	<ol style="list-style-type: none"> <li>1. Drift</li> <li>2. Connector loose</li> <li>3. Electrolytic capacitors failed</li> </ol>
Logic-module failure	<ol style="list-style-type: none"> <li>1. Electronic component failure</li> <li>2. Test procedure deficient</li> </ol>
Miscellaneous-component failure	<ol style="list-style-type: none"> <li>1. Terminal block cracked</li> <li>2. Trip-module logic repaired</li> </ol>
<i>Sensors and Transmitters</i>	
RTD failure	<ol style="list-style-type: none"> <li>1. Resistance changed out of limits</li> <li>2. Failed open</li> <li>3. Low insulation resistance</li> </ol>
Capacitance-type pressure transducers obsolescence	<ol style="list-style-type: none"> <li>1. Replaced due to obsolescence with later model</li> </ol>
Strain-gauge-type pressure transducer failure	<ol style="list-style-type: none"> <li>1. Seal failure on transducer</li> <li>2. Transducer amplifier failed</li> </ol>
Pressure-switch failure	<ol style="list-style-type: none"> <li>1. Seal failure</li> <li>2. Fails to operate</li> </ol>
Ion chambers	<ol style="list-style-type: none"> <li>1. Noisy or erratic</li> <li>2. Low insulation resistance</li> <li>3. Chamber power supply failed</li> </ol>
Scram breaker failure to open.	<ol style="list-style-type: none"> <li>1. Undervoltage trip malfunction</li> <li>2. Mechanism malfunction</li> <li>3. Coil burned</li> <li>4. Weld failure</li> <li>5. Shunt trip foil overheated</li> <li>6. Subcomponents sticking</li> <li>7. Wear</li> </ol>

3. Change in boundary conditions, such as moving a cable that has been in a high temperature or radiation environment for years
4. Common-mode failures causing abnormal stress on other components
5. Trends established from data bases or historical records.

## Product Number 5—Current Inspection, Surveillance, and Monitoring Methods

The detailed description of the RTS and ESFAS included a discussion of testing methods and technical specification requirements. At the representative plant studied, a separate group (called the performance group) is set up to perform all the plant performance testing except for the RTS and ESFAS. The tests on these systems are performed by the maintenance department.

All testing, regardless of which group does it, is done according to detailed test procedures. After maintenance is performed, the affected components or channels are retested.

Testing methods include visual inspection and functional testing of components, channels, and systems. Due to channel redundancy, a channel is locked out of plant operation during functional testing so as not to trip the reactor should a problem occur. For the RTS, one channel is tested each week, so that the complete system will be tested at least once a month. The same procedure is true for the ESFAS.

All tests are documented on the test procedure forms and filed for future reference. Any abnormal conditions noted (i.e., a measured parameter off by more than  $\pm 2.0\%$ ) must be corrected before the channel is put back in service. Thus, maintenance is closely associated with testing.

## Product Number 6—Current Maintenance Practices

**Plant Maintenance Activities.** The RTS and ESFAS are just two of the many systems for which a

nuclear power plant maintenance department has responsibility. On the average, only about 10% of the problems are related to failures or major disfunctions. The remainder are concerned with minor components, or minor problems with major components. Typical difficulties are recorder pens not inking, leaks, low oil levels, and erratic instruments.

In general, maintenance activities fall into four categories: (a) scheduled maintenance, (b) problems found during operation or testing, (c) problems found during scheduled maintenance, and (d) plant modifications. When a problem is found that requires maintenance, a work request is written to initiate the activity. Utilities that use the work request system generally find these systems improve the planning and control of maintenance work.

The plant maintenance group is usually supported by an engineering group that handles major modifications. Production maintenance includes both CM and PM. Most utilities have developed maintenance programs that are helpful in meeting applicable INPO objectives.

### Regulatory Approach to Plant Maintenance.

Currently, the USNRC regulatory approach to nuclear plant maintenance concentrates on quality assurance and surveillance requirements. Quality assurance is applied to design, construction, and operation for structures, systems, and components important to safety (10 CFR 50 Appendix B). Surveillance requirements are found in 10 CFR 50.36. These maintenance requirements apply only to safety-related systems.

The SRP covering equipment qualification of mild environment equipment includes as one of the review items a minimum 18 month review of maintenance program data. Other key phrases in the USNRC SRP are a *good preventive maintenance program* and *well-supported maintenance program*. The IEEE Standard 338-1977, which covers the criteria for periodic testing, calls for corrective action such as maintenance or repair following a failed test and before the successful completion of a repeat test.

## CONCLUSIONS

The conclusions from this review of operating experience on the RPS and practices of commercial nuclear power plants are given below for each major objective. The objective is restated and is followed by the important findings and conclusions associated with it.

**Objective 1:** Review operating experience and practices of commercial nuclear power plants to determine the significance of aging as a contributor to degradation of RTS and ESFAS.

**Findings:** The NPE and LER data-base review provided information on the components and sub-components that were involved most frequently in RTS and ESFAS faults, as well as a summary of causes cited in the events. Pressure channels have the highest number of events for all NSSS vendors, except GE. Level channels had the highest with GE, with pressure channels second. At the subcomponent level, the five categories with the highest number of occurrences were: sensors and transmitters, electronic parts, bistables, power supplies, and breakers. About 55% of pressure channel problems involved drift. Total pressure transducer failure was relatively infrequent, comprising only about 2.7% of the events. Operator and maintenance error top the list for causes, followed by I&C component failure, design errors, mechanical wear, and drift.

From NPE, just under half of the events are considered aging-related (49.3% for RTS and 47% for ESFAS). The aging contribution will be further developed in Phase 2. The LER data base had a demand failure rate which is defined as the probability (per demand) that a component will fail to operate when required to start, change state, or function. About 25% of the faults listed for RTS fell into this category. If the actual demands on the system average 4.6 per year, and testing demands are estimated at 100 times a year per plant, then a large part of the demand faults are due to testing. This is estimated to be the number of testing demands divided by the sum of testing demands plus actual demands times 25% or about 24%. Thus, the wear due to testing is roughly proportional to the number of cycles due to testing compared to the total number of cycles per year.

Usually, only a channel is degraded or inoperable when a fault occurs in the RPS. Therefore, because of redundancy, the effect of RPS faults on the plant functions is minimized.

Based on data from the NPRDS the loss of total RPS function occurred only 0.2% of the time when a RPS component failed. Thus, most of the time the channel can be locked out, repaired, and returned to service without affecting the plant function (i.e. power generation).

If the failed channel completes one of a two-out-of-four logic scheme, then the failure does not result in a reduction of plant safety protection. However, it could impact plant operation because a false reading from any of the remaining channels would result in a plant trip. For the representative plant studied, the failed channel would be locked out for maintenance and the RPS would be operated on a two-out-of-three logic scheme until repairs were completed. If on the other hand, the affected channel fails in a manner that prevents a channel from tripping, the effect on plant operations is different and it could have a direct impact on plant safety. However, the requirements of 10 CFR 50, Appendix A (criterion 23) requires the design to be such that the protection system fails into a safe state upon disconnection, loss of power or exposure to postulated adverse environments. But, there could still be an undetected or unanalyzed failure mode which would be in the unsafe direction.

Any failure affecting the function or reliability of the RPS ultimately has an effect on plant safety (unnecessary trips that challenge plant safety equipment and impose transients on the plant eventually have an impact on overall plant safety), but the different types of failures

have very different effects. If aging-related failures tend to increase false trips, rather than prevent trips, such information would be important in addressing the consequences of aging.

One example of a component failure related to aging that prevented reactor trip was the sticking of an undervoltage relay associated with scram breakers. This has occurred at a number of plants, but the February 1983 event at the Salem Nuclear Power Plant was most notable. The problem is being corrected through redesign by vendors and enhanced maintenance by the utilities.

Those faults that can be detected by indicators are identified, and maintenance may then be performed to correct the fault. Consequently, an enhanced maintenance program, coordinated with testing, almost makes aging a nonproblem on redundant systems such as the RPS, because the periodic rejuvenation does not allow the system to grow old. The only exception would be the cables associated with RPS in containment. The significance of aging on cables in containment is still an unknown.

In general, plant records support the information found in the various data bases. However, plant records contain much greater detail and many more events that are not required to be reported to the USNRC, or other groups.

**Objective 2:** Perform a detailed generic study of the RTS and ESFAS for a representative PWR using representative plant design information, specifications, operation and maintenance manuals, and historical records. For each type of instrument channel used in these systems, identify the materials and components that experience degradation due to aging in the various plant environments and operating modes.

**Findings:** The RPS is operational for all reactor operating modes, including cold shutdown when end-to-end calibration and repairs are performed. Those components in containment experience severe environments of nuclear radiation, 120°F average temperature, and high humidity. Because of the severe environment, these components are qualified for a specified period of time and are changed out on or before the due date. Subcomponents (such as O-ring seals, electronic boards, and valve packing) are changed more often during maintenance periods, thus extending the life of major components. The materials and subcomponents subject to aging are presented in the tables of materials for each of the sensors, in the aging data included with the one-line diagrams, and in Table 20, which summarizes materials in containment subject to aging.

Detailed studies were performed on RTS and ESFAS systems for a representative B&W plant. These studies included looking at detailed drawings, plant records, and actual test procedures. Instrumentation channels, which provide the sensing for RTS and ESFAS, were also reviewed. Plant personnel were interviewed. Plant visits and interviews are necessary in order to obtain the plant conditions and actual operating experience. For example, excessive drift usually meant a component had degraded, as did abnormal voltages, currents or response times. Scram breakers receive routine maintenance and are refurbished quarterly.

A summary of RTS/ESFAS systems component problems related to testing and aging are:

1. Sensors—All sensors in containment now have to be qualified to a specific life time and changed out at, or before, the time that life time ends.
  - a. Pressure—Problems include sample line blockage, sensor failure, and seal failure. The cause of sensor failure is usually not given but is sometimes included under the heading of electronics as

*catastrophic*. Drift, calibration, and personnel error are listed as having the highest percentages of occurrence. Total failure of a sensor occurs relatively infrequently.

- b. Flow—Power supplies, amplifiers, and signal converters/transmitters are most often mentioned as problem areas.
  - c. Temperature—Problems include broken connectors, lead damage related to maintenance and testing. Resistance change may be aging related in RTDs. Broken connectors and lead damage apply primarily to thermocouples, which are not used in Class 1E safety systems of the plant studied, but are listed in data bases as part of RTS.
2. Connectors—Tests and calibration of sensors often require handling connectors. Most problems are assembly errors, handling, and environmental. The problems cover all aspects of wire and cable termination, i.e., cold solder joints, inadequate stress relief, loose pins and lugs, mechanical failure, moisture-induced conductivity, and corrosion.
  3. Cables and wires—Temperature measurement channels had the most wire problems. Otherwise, there were few problems with instrument wire and cables, except that removing cables at pressure boundaries requires breaking the seal and splicing cable. Problems have been noted due to moisture, steam-line breaks, or mechanical damage.
  4. Circuit breakers—Problems are breaker faults, operator errors, and common-mode faults caused by other equipment faults. Mechanical parts are subject to wear due to testing. Routine maintenance and refurbishment minimized breaker problems at one plant.
  5. Relays—These are similar to circuit breakers, with most problems listed as mechanical failure, coil failure, contact failures, and response to mechanical shock. Some relays can be qualified for a cycle life in excess of expected plant 40-year requirements, which reduces problems found during surveillance maintenance.
  6. Electronic components—These have random failure as the major failure mode. This includes amplifiers, power supplies, bistables, capacitors, transistors, and comparators. Drift is also an often-mentioned problem for amplifiers and power supplies. Electrolytic-capacitor failure in power supplies may be an aging-related problem.
  7. Measurement channels and subsystems—Individual component failures are a minor contributor to RTS/ESFAS failure frequency, due to design redundancy. The most dominant contributor to RTS/ESFAS failure frequency is common-cause failures and human errors.
  8. Drift—Setpoint drift problems are influenced by the initial selection of instruments, their range, application, calibrations, operations, and maintenance. The most prevalent reason for setpoint drift was component degradations, assuming that there was sufficient margin for normal instrument error. Most drifts are discovered by testing, whereas most I&C failures are generally not discovered by testing, but rather at the time of failure.
  9. Degradation due to functional testing cycles and trips—This is part of the aging process and difficult to quantify. It is roughly equal to the ratio of test cycles to total cycles (operations) the equipment experiences. Because the test interval is short compared to the aging time to failure for the RPS, testing contributes to aging and the number of cycles on hardware.

Objective 3: Identify the essential auxiliary support systems for the RPS.

Findings: The RPS has two essential support systems: Class 1E power and heating, ventilating, and air conditioning. The loss of power will trip the affected portion of the RPS. The loss of the

HVAC may allow cabinet temperatures to rise, but the effect on electronic components is unknown.

**Objective 4:** Review Regulatory issues pertinent to the RPS and the utilization of research results in the regulatory process, including relevant standards and technical specifications.

**Findings:** The regulatory standards and guidelines for RPS were listed in Table 19, including those for equipment qualification and testing. Issues to be resolved were identified in the remarks column.

**Objective 5:** Assessment of adequacy of current testing programs based on findings in above tasks.

**Findings:** In general, testing programs are adequate for the intended purpose of verifying operability and performance. However, a different kind of data needs to be recorded for trend analysis and aging studies. This is the performance parameters and functional indicators which are useful for trending. In some cases, quality of testing may be substituted for quantity of testing. As plants upgrade their systems with more computer monitoring the practicality of collecting trending data increases.

The current testing requirements in technical specifications may need revision to allow any recommended increase in surveillance test intervals and allowable downtimes, based on reliability studies completed by NSSS vendors and others. The right kind of data needs to be collected and baseline data bases established by utilities to better support aging and life-extension goals. Maintenance and testing must be coordinated to minimize redundant testing. Response time of sensors should not be overlooked if the response time to a process is an important safety factor.

**Objective 6:** Based on the information collected on RPS from the various data bases, plant records, and site visits, summarize the products asked for in the Phase 1 NPAR guidelines. These are:

**Objective 6.a.** Provide preliminary identification of materials susceptible to aging degradation.

**Findings:** A summary of materials susceptible to aging degradation was given in Table 20, and subcomponents identified in the one-line diagrams for the RPS channels. In general, materials identified most often as *weak link* materials are electrical insulation, seals and gaskets, and electronic components.

*It is recommended that plant records for life extension include identification of materials, stressors, environment, and detailed failure analysis.*

**Objective 6.b.** Determine stressors and related environmental factors causing aging degradation for both normal operation and accident conditions.

**Findings:** Stressors can be classified into three categories: environmental, operational, and maintenance-related. These stressors apply under all operating conditions including accident and postaccident. Examples of environmental stressors are abnormal temperatures, temperature cycles, radiation, humidity, and vibration. Operational stressors include process fluctuation, electrical transients, and switching transients. Handling of cables and connectors during calibration and testing is an example of maintenance-related stress. Accident conditions may have more severe stresses and sequence of stresses, depending on the nature of the accident. For example, a steam line break could include a combination of high temperature, water, and radiation.

Objective 6.c. Identify failure modes experienced during operation and their causes.

Findings: Failure modes observed during the review of operating experience on RPS were presented in Table 21. Included are failure modes for the system, individual channels, and components. The leading causes of failure are: drift; piece part failure; human error in operations, testing and maintenance; mechanical malfunctions; electrical malfunction; and design errors. Due to redundancy of channels, total RPS systems failure is a relatively rare event. When it does occur, it is usually the result of a common-mode failure or human error. For example, the wrong set points on two or more channels could shut down the system when discovered. Another example of a common-mode failure would be an air conditioning failure that would allow electronics to overheat in equipment racks.

Objective 6.d. Identify functional indicators or degradation that may occur during plant life due to aging.

Findings: Functional indicators may be any observed change from expected values of measured parameter during test and calibration. Also, any abnormal observation from visual inspection or plant operations may be an indicator. The RPS channel degradation indicators were summarized in the discussion of NPAR product number 4. In addition, trends observed from analysis may be indicators.

Objective 6.e. Determine the current inspection, surveillance, and monitoring methods.

Findings: Methods include observing like channels during operation and noting any abnormal deviations. One channel is tested every week on a rotating basis that meets or exceeds technical specification requirements. All inspections and tests are done according to written procedures and documented. On RPS, most functional testing is performed by actuating the channel, including the trip relay or breaker, using built-in test modules to initiate the test. Additional voltage and current measurements are taken (as required by procedures) during maintenance and verification testing.

Objective 6.f. Determine the role of current maintenance practices in mitigating the effects of aging.

Findings: The USNRC regulatory approach concentrates on quality assurance and surveillance requirements that apply only to safety-related systems. Most utilities perform additional PM, such as refurbishing trip breakers on a quarterly basis; this mitigates aging effects on breakers. Maintenance and testing of RPS are closely coordinated at the representative plant studied. Any measured parameter observed during testing that is more than 2.0% off the expected value receives maintenance to correct the problem before the channel is returned to service—thus mitigating aging to some extent. At this plant, the maintenance department also performs the testing of RPS, ensuring immediate attention to problem areas including degradation due to aging.

## REFERENCES

1. *Nuclear Plant Aging Research Program Plan*, NUREG-1144, June 1985.
2. B. M. Meale and D. G. Satterwhite, *An Aging Failure Survey of Light Water Reactor Safety Systems and Components*, NUREG/CR-4747, EGG-2473, Idaho National Engineering Laboratory, July 1987.
3. V. N. Shaw, *Residual Life Assessment of Major Light Water Reactor Components-Overview, 1*, NUREG/CR 4731, EGG-2469, Idaho National Engineering Laboratory, June 1987.
4. G. L. Toman, *Inspection, Surveillance, and Monitoring of Electrical Equipment Inside Containment of Nuclear Power Plants—2. Pressure Transmitters*, NUREG/CR-4257.
5. *In-situ Response Time Testing of Platinum Resistance Thermometers, 1, 2*, EPRI NP-834, 1978.
6. R. T. Johnson, F. V. Torne, and C. M. Croft, *A Survey of the State-of-the-Art in Aging of Electronics with Application to Nuclear-Power Plant Instrumentation*, NUREG/CR-3156, February 1983.
7. C. F. Miller et al., *Data Summaries of Licensee Event Reports of Selected Instrumentation and Control Components at U.S. Commercial Nuclear Power Plants, January 1, 1976 to December 31, 1978*, NUREG/CR-1740, EGG-2307, May 1981.
8. R. S. Enzinna, "Optimization of Reactor Trip System Test Intervals," *Reliability Conference for Electric Power Industry, Las Vegas, Nevada, April 1984*.
9. *Oconee PRA, A Probability Risk Assessment of Oconee Unit 3, June 1984*, cosponsored by the Nuclear Safety Analysis Center Electric Power Research Institute, Palo Alto, California and Duke Power Company, Charlotte, North Carolina.
10. *Standard Technical Specifications for Babcock and Wilcox Pressurized Water Reactors*, NUREG-0103, Revision 4, Fall 1980.
11. *Criteria for Protection Systems for Nuclear Power Generating Stations (ANSI N42.7-1972)*, IEEE 279-1971, Institute of Electrical and Electronics Engineers.
12. Code of Federal Regulations, Title 10, Energy.
13. *Review of Licensee Event Reports (1976-1978)*, NUREG-0572, U.S. Nuclear Regulatory Commission, September 1979.
14. "Environmental Qualification of Class 1E Equipment," IE Bulletin 79-01B, January 14, 1980.
15. *Qualifying Class 1E Equipment for Nuclear Power Generating Stations*, IEEE-323-1974 (Reaff 1980).
16. *Recommended Practices for Seismic Qualification of Class 1E Equipment for Nuclear Power Generating Stations (ANSI/IEEE)*, IEEE-344-1975 (Reaff 1980).
17. *Standard Review Plan for the Review of Safety Analysis Reports for Nuclear Power Plants*, NUREG-0800, July 1981.
18. *Criteria for the Periodic Testing of Nuclear Power Generating Stations Safety Systems*, IEEE-338-1977.

19. *Initial Test Programs for Water-Cooled Nuclear Power Plants*, Regulatory Guide No. 1.68.
20. *Periodic Testing of Electric Power and Protection Systems*, Regulatory Guide No. 1.118.
21. *Periodic Testing of Protection System Actuation Functions*, Regulatory Guide No. 1.22.
22. *Oconee 3 Nuclear Plant*, Final Safety Analysis Report, Docket No. 50-317, Chapter 7, Operating License, February 6, 1973.
23. *Standard Technical Specifications for General Electric Boiling Water Reactors*, NUREG-0123, Revision 3, Fall 1980.
24. *Standard Technical Specifications for Combustion Engineering Pressurized Water Reactors*, NUREG-0212, Revision 2, Fall 1980.
25. *Standard Technical Specifications for Westinghouse Pressurized Water Reactors*, NUREG-0452, Revision 4, Fall 1981.
26. Generic Letter 83-28, "Required Actions Based on Generic Implications of Salem ATWS Events," July 8, 1983.
27. *Technical Specifications - Enhancing the Safety Impact*, NUREG 1024, November 1983.
28. *Evaluation of Surveillance Frequencies and Out-of-Service Times for the Reactor Protection Instrumentation System*, Westinghouse Electric Corporation, WCAP-10271, January 1983, and *Supplement No. 1*, July 1983.
29. L. P. Gradin and J. M. Twomey, *Reliability Based Maintenance to Reduce Cost and Improve Safety*, *Nuclear Plant Safety*, 3, May-June 1985, p. 6.
30. S. P. Carfagno and R. J. Gibson, *A Review of Equipment Aging Theory and Technology*, EPRI NP-1558, September 1980.

## BIBLIOGRAPHY

The following references contain background information but were not cited in the report. Additional references on scram breakers and relays are found in Appendixes A and B.

*IEEE Standard Criteria for Safety Systems for Nuclear Power Generating Stations*, Std. 603, Institute of Electrical and Electronic Engineers, 1980.

Jacobs, I. M., Reliability of Engineered Safety Features as a Function of Testing Frequency, *Nuclear Safety*, 9, 4, July-August 1968, pp. 303-312.

*Scram Reduction by Relaxing Set Points: An Analysis of Combustion Engineering PWRs with Analog Controls Using RETRAN-02*, EPRI Final Report NSAC-092, November 1985.

*Scram Reduction by Relaxing Set Points: An Analysis of C-E PWRs with Digital Controls Using RETRAN-02*, EPRI Final Report NSAC-093, January 1986.

*Reducing Scram Frequency by Modifying Reactor Set Points for a Westinghouse 4-Loop Plant*, EPRI Final Report NSAC-094, April 1986.

*A Guide to Qualification of Electrical Equipment for Nuclear Power Plants*, EPRI NSAC-58, September 1983.

Perla, H. F., et al., *A Guide for Developing Preventive Maintenance Programs in Electric Power Plants*, EPRI NP-3416, May 1984.

Vesely, W. E., et al., *FRANTIC II - A Computer Code for Time Dependent Unavailability Analysis*, NUREG/CR-1924, BNL-NUREG-51355, April 1981.

Ginzburg, T., J. L. Boccio, and R. E. Hall, *FRANTIC II - Applications to Standby Safety Systems*, NUREG/CR-3627, BNL-NUREG-51738, December 1983.

Hallgren, B. and P. Ofverbeck, "Some Practical Aspects on Maintenance Interval Optimization," *Proc. 12th Inter-RAM Conf. Electric Power Industry, Baltimore, MD, April 9-12.*

*Reliability-Centered Maintenance*, United Airlines, Report No. AD-A066 579, December 1978.

Seminara, J. L., W. R. Gonzalez, S. O. Parsons, *Maintainability Assessment Methods and Enhancement Strategies for Nuclear and Fossil Fuel Power Plants*, EPRI NP-3588, July 1984.

"Seminar on Nuclear Power Plant Life Extension," *Seminar Proceedings Sponsored by EPRI, DOE, Northern States Power, and Virginia Power, August 25-27, 1986.*

*The IEEE Guide to Collection and Presentation of Electrical, Electronic Sensing Component, and Mechanical Equipment Reliability Data for Nuclear Power Generating Stations*, IEEE Std 500-1984, The Institute of Electrical and Electronics Engineers, Inc.

*Response Time Testing of Nuclear Safety-Related Instrument Channels in Nuclear Power Plants*, Draft ISA Standard, ISA-dS67.06, Instrument Society of America, Research Triangle Park, North Carolina, August 21, 1984.

Strahm, R. C. and M. E. Yancey, "TMI-2 Pressure Transmitter Examination Program Year End Report: Examination of Pressure Transmitters CF-1-PT3 and CF-2-LT3," GEND-INF-029, EG&G Idaho, Inc., February 1983.

*Functional Criteria for Emergency Response Facilities*, Final Report, U.S. Nuclear Regulatory Commission, Division of Emergency Preparedness, NUREG-0696, February 1981.

Jolly, M. E. and J. Wreathall, "Common-Mode Failures in Reactor Safety Systems," *Nuclear Safety* 18(5), September-October 1977, pp. 624-632.

*IEEE Recommended Practices for Seismic Qualification of Class 1E Equipment for Nuclear Power Generating Stations*, IEEE Std. 344-1975, New York: The Institute of Electrical and Electronics Engineers, January 1975.

Bonzon, L. L., *An Experimental Investigation of Synergisms in Class 1 Components Subjected to LOCA Type Tests*, Albuquerque, New Mexico: Sandia Laboratories, August 1978. SAND78-0067 U.S. Nuclear Regulatory Commission Report No. NUREG/CR-0275.

Ames, J., et al., "Probabilistic Analysis of Accidental Transients in Nuclear Power Plants," *Nuclear System Reliability Engineering and Risk Assessment*, Fussell and Burdick (eds.), Society for Industrial and Applied Mathematics, 1977.

*Generic Implications of ATWS Events at the Nuclear Power Plant, 1 and 2*, NUREG-1000, U.S. Nuclear Regulatory Commission, April 1983.

*Anticipated Transients Without SCRAM for Light Water Reactors*, NUREG-0460, U.S. Nuclear Regulatory Commission, April 1978.

*A Method for Determining Requirements for Instrumentation Control and Electrical Systems and Equipment Important to Safety*, IEEE P-827, Institute of Electrical and Electronics Engineers.

*Set Points for Nuclear Safety-Related Instrumentation Used in Nuclear Power Plants*, ISA S67.04 (ANSI N719), Draft F, Instrument Society of America, May 22, 1979.

*RPS/ESFAS Extended Test Interval Evaluation Report Prepared by C-E Owners Group*, CEN-327, May 1986.

Enzina, R. S., et al., *Justification for Increasing the Reactor Trip System On-Line Test Intervals*, BAW 10167, May 1986.

Al-Hussaini, T. J. and J. E. Stoner Jr., "Ongoing Qualification of Cable in a Pressurized Water Reactor Environment," *Presented at the Nuclear Science Symposium, Orlando, Florida, November 1, 1984.*

*Electrical Penetration Assemblies in Containment Structures for Nuclear Power Generating Stations*, 317-1983 (ANSI/IEEE) (Revision of IEEE Std. 317-1976).

*Standard for Type Test of Class 1E Electric Cables, Field Splices, and Connections for Nuclear Power Generating Station*, 383-1974, (ANSI/IEEE) (Reaff 1980).

**APPENDIX A**

**AN EVALUATION OF INFORMATION SOURCES FOR AGING  
RESEARCH ON REACTOR PROTECTION SYSTEMS**

## SUMMARY

The U.S. Nuclear Regulatory Commission established a Nuclear Plant Aging Research Program in 1982 to address the safety issues associated with aging nuclear plants. This report presents an evaluation of the information sources (both generic data bases and plant records) that have been used for aging studies of the Reactor Protection Systems (RPS). In reviewing data bases, one must remember that initially they were each set up for a specific purpose. Although they contain vast amounts of information on nuclear plant components, systems, and events, they may not contain all the information needed for aging research or other specific applications.

The generic data bases evaluated in this study included the Nuclear Power Experience (NPE), Licensee Event Reports (LERs), and the Nuclear Plant Reliability Data System (NPRDS). Specific plant records included the Corrective Maintenance (CM) data base and the Incident Investigation Reports (IIR) supplied by a cooperating utility. Events from each of these data bases, coded under RPS for the nuclear plant selected, are listed in chronological order starting on October 23, 1980, and continuing through April 25, 1985. The percentage of events covered by each data base for the period of time its data was available is CM, 100%; IIR, 32%; NPE, 23%; NPRDS, 36%; LER reported under 10 CFR 50.72 (before 1984), 65%; and LER reported under 10 CFR 50.73 (after

January 1, 1984), 7%. However, during earlier years, there were events associated with procedural changes due to analytical errors and technical specifications not implemented that may not have been included in the CM data base. Thus, the overall coverage of the CM data base was probably less than 100% in those years.

The CM records are clearly the most complete source of RPS failure data. They also include information on incipient failures because they show that many potential problems are fixed before major system or channel failure occurs. The IIRs are internal reports and form the basis for LER reports. Thus, both the LERs and NPRDS are a subset of these in-plant reports. The NPE includes a selection of LERs and other sources available in the public domain.

The conclusions from this study are based on the records from only one plant and may not be valid for all plants. However, the implications are that the generic data bases may not provide a representative sample of aging-related failures for a nuclear power plant. In general, the generic data bases agree on what system components fail most frequently (top six for frequency of failure). However, the various data bases list quite different failure causes. Trend data needed for aging studies is not available from the generic data bases and, except for major components, is probably not available from most utility maintenance records either.

## APPENDIX A

# AN EVALUATION OF INFORMATION SOURCES FOR AGING RESEARCH ON REACTOR PROTECTION SYSTEMS

## CONTENTS

SUMMARY .....	A-2
INTRODUCTION .....	A-5
INFORMATION REQUIREMENTS FOR AGING RESEARCH .....	A-6
GENERIC INFORMATION SOURCES .....	A-7
NPE Data System Description .....	A-7
Licensee Event Report System .....	A-7
Nuclear Plant Reliability Data System .....	A-8
In-Plant Reliability Data System .....	A-8
PLANT DATA SOURCES .....	A-10
Incident Investigation Reports .....	A-10
Nuclear Maintenance Data Base .....	A-10
APPLICATION OF DATA BASES TO RPS AGING RESEARCH .....	A-11
CONCLUSIONS .....	A-18
REFERENCES .....	A-20

## TABLES

A-1. RPS failure category fractions from NPRDS .....	A-11
A-2. RPS system effect fractions from NPRDS .....	A-11
A-3. RPS component categories ranked by event report frequency .....	A-12
A-4. RPS failure cause categories ranked by event report frequency .....	A-12
A-5. Chronological list of RPS events from all data sources for a selected PWR .....	A-14
A-6. Percentage of events covered by each data base for period of time data was available and reviewed .....	A-16

## APPENDIX A

# AN EVALUATION OF INFORMATION SOURCES FOR AGING RESEARCH ON REACTOR PROTECTION SYSTEMS

## INTRODUCTION

The U.S. Nuclear Regulatory Commission (USNRC) has established a Nuclear Plant Aging Research (NPAR) Program to address nuclear power plant aging-related safety issues. One of the objectives of the NPAR Program is to provide the necessary information to maximize the operating plant lifetime safely. The NPAR Program Plan (NUREG-1144)<sup>A-1</sup> calls for a phased research program. Program progress to date has been concentrated in Phase 1 and focused on (a) identifying the important degradation mechanisms and their impact on plant operations, and (b) evaluating the methods used to detect and control the effects of degradation. Specific light water reactor (LWR)-oriented data bases are identified in NUREG-1144, as information sources for operating experience reviews, i.e., Nuclear Plant Reliability Data System (NPRDS) and In-Plant Reliability Data System (IPRDS).

The objective of this study is to review the information available from the generic data bases as well as selected plant data bases and to identify specific limitations and deficiencies in the use of these data bases for aging and life-extension studies. Records for the Reactor Protection System (RPS) were chosen because the RPS was used in a pilot aging study<sup>A-2</sup> and the RPS system boundaries are well defined in both the generic data bases and plant records.

Some questions to be answered regarding the use of data systems for aging research are:

1. Which, if any, of the generic data bases contain a representative sample of nuclear power plant safety systems problems and failures due to aging?

2. How well do the data bases agree on frequency and cause of the component failures?
3. Is it necessary to examine plant records (go to the nuclear plants) to get the trend information needed for aging research?
4. What additional information needs exist that are not satisfied by current data sources?

The generic data bases used in this study were the Nuclear Power Experience (NPE), NPRDS, and the Licensee Event Reports (LERs). The plant records (data base summaries) included the corrective maintenance (CM) records, and the Incident Investigation Reports (IIRs) supplied by a cooperating utility for a specific plant.

The NPE is available to the general public through a subscription service for an initial setup fee and an annual fee. Licensee Event Reports are compiled and published monthly as NUREG-2000. Access to the NPRDS is controlled by the Institute of Nuclear Power Operations (INPO) and that data base is intended primarily for use by utilities that own and operate nuclear power plants and the USNRC. The IIRs and CM data summaries are internal utility documents that are not distributed outside the utility.

The aging research information requirements are discussed in the next section, followed by a description of the data systems along with some background and historical information. Then, a discussion of the application of data bases to aging research is given, and finally the conclusions and references.

## INFORMATION REQUIREMENTS FOR AGING RESEARCH

Nuclear plant aging is a degradation process that exists at every level in the plant system. If left undetected and unrepaired, the aging process could increase risk associated with plant operations. Ultimately, any plant life extension will depend on mitigating the effects of aging degradation on components, systems, and structures. Information about the plant components and systems is required for:

1. Identifying the type(s) and location(s) of significant degradation mechanisms, such as thermal and radiation damage to cables in the reactor containment
2. Characterizing aging mechanisms (materials, conditions, dynamics, etc.) to improve understanding and mathematically model the processes
3. Detecting the necessary parameters to estimate and control aging degradations (inspection, surveillance, monitoring, etc.)
4. Determining successful control strategies (maintenance, repair, replacement, chemistry/fluence/vibration control, etc.)
5. Estimating the life (or residual life) of components, systems, structures, and, hence, the plant.

Certainly most of these issues have been considered in the design, construction, and operation of the plant, but perhaps not in an optimal fashion. An objective of plant aging research is to provide the necessary information to satisfy the above requirements.

## GENERIC INFORMATION SOURCES

There are no shortages of data bases that contain U.S. and international nuclear operating experience.<sup>A3-A8</sup> However, the NPE, NPRDS, and LERs (reported under 10 CFR 50.72 and 10 CFR 50.73) data bases have been the most widely used information sources. Both NPE and NPRDS have restricted use based on proprietary agreements. The plant CM records and the IIR reports are not found in any data base outside the utility, although information may be extracted from these internal reports by the utility to satisfy external reporting requirements.

It is important for the investigator using a data base to understand the features of the information presented, including the purpose, method of data acquisition, quality control, and any other limitations that may be applicable for the intended use. The data bases have evolved with time, changing in response to user needs and USNRC and other requirements. The references contain important insights other researchers have gained through the use of these sources. Comparison may be complicated by the diversity among the sources; therefore, an integration of appropriate data from each source may provide the best results. These data bases provide a broad base from which to assess overall population trends. Frequently, the LERs or NPRDS reports from a single unit provide too small a sample to reach any significant conclusions, making the use of aggregate experience desirable. Comparison of the unit experience with trends in industry experience can be informative.

### NPE Data System Description

The NPE was developed and introduced in 1972 by the S. M. Stoller Corporation at Boulder, Colorado. This system contains information on boiling water reactors (BWRs) and pressurized water reactors (PWRs) available from the public domain. As of June 1985, the NPE system contained 24,355 articles on more than 50,000 events. The index and key words are computerized, which allows a rapid search of the system for specific articles with titles and reference numbers to the hard copy volumes. The system is updated quarterly and appears to be a convenient one from which to obtain generic information on problem areas. However, the system has no capability, at present, to retrieve individual vendor component information other than major nuclear steam supply systems. The NPE articles typically contain more

information than the LER abstracts discussed below because of the additional research conducted.

### Licensee Event Report System

The Code of Federal Regulations requires that nuclear power plants report significant events to the USNRC. Those reportable occurrences that occurred before 1984 were reported to the USNRC in accordance with Title 10 Part 50.72 of the Code of Federal Regulations;<sup>A-8</sup> Regulatory Guide 1.16, *Reporting of Operating Information - Appendix A, Technical Specifications*;<sup>A-9</sup> and NUREG-1061, *Instructions for Preparation of Data Entry Sheets for Licensee Event Reports*.<sup>A-10</sup> For those events occurring on and after January 1, 1984, LERs were submitted in accordance with the revised rule contained in Title 10 Part 50.73 of the Code of Federal Regulations.<sup>A-11</sup> Supporting guidance and information on the revised LER rule are found in NUREG-1022, *Licensee Event Report System - Description of Systems and Guidelines for Reporting*.<sup>A-12</sup>

Reportable occurrences include personnel error or procedural inadequacy that (during normal operation, anticipated operational occurrences, or accident conditions) prevent, or could prevent, by itself, the fulfillment of the safety function of those structures, systems, and components important to safety that are needed to:

1. Shut down the reactor safely and maintain it in a safe shutdown condition
2. Remove residual heat following reactor shutdown
3. Limit the release of radioactive material to acceptable levels or reduce the potential for such release.

These significant events are reported to the USNRC by telephone within 1 hour, with written follow-up in 14 days. Other events, such as minor technical specification violations that do not prevent the fulfillment of the functional requirements of the affected system are reportable in 30 days.

In 1973, the Atomic Energy Commission (AEC) established a computer-based file of information extracted from the licensee reports. This data system became known as the LER file. Before December 31, 1981, the USNRC had two separate computerized data systems for processing LER information. These systems were physically located at the National

Institute of Health (NIH-LER) in Bethesda, Maryland and the Nuclear Safety Information Center (NSIC-LER) in Oak Ridge, Tennessee. The NIH-LER data base was phased out and the NSIC-LER data file continued in a slightly modified format. The LERs were then published in a monthly report (NUREG/CR-2000) from the NSIC-LER data file.

The pre-1984 LER data base has been used as a source of reliability data. The weaknesses of the pre-1984 LER system as a reliability data base are<sup>A-13</sup>:

1. The LER data base does not contain plant population data
2. Failures of nonsafety components may, or may not, be reported and LERs are not submitted for every plant component
3. Not every type of failure is a reportable event, even if the component was a safety class component
4. Inconsistencies in reporting due to many plants and individuals involved.

Events reported to the LER system after January 1, 1984, are only those that are, or lead to, safety-significant events. Under the new rule (10 CFR 50.73), an LER is not required unless the limiting condition for operation (LCO) and its associated actions statement are not met. If a component fails and can be replaced within the time constraint of the LCO, no LER is required. Information on component failures that were previously reported through the LER system will now be reported through the NPRDS.

## **Nuclear Plant Reliability Data System**

The NPRDS was developed by the Equipment Availability Task Force of the Edison Electric Institute (EEI) in the early 1970s under the direction of the American National Standards Institute (ANSI). The NPRDS was maintained by the Southwest Research Institute (SRI) under contract to the EEI through 1981. Since January 1982, the NPRDS has been under the direction of the INPO.

The NPRDS contains two files: one on engineering data and one on failure data. The engineering file contains descriptive information for safety-related systems and components for each unit, such as unit name, owner, component or system code designation, safety class, manufacturer model and serial number, operating environment, drawing number, and operation and testing data, submitted

on a standard report form and updated as required. A quarterly operating report, submitted by the utility on a standard report form, includes such information as unit name, owner, on-line time in hours, reactor critical hours, standby and shutdown hours, and number of failure reports for the quarter. A report of failure form, submitted quarterly by the utility on a standard report form, includes such information as unit name, owner, failed component or system code, component identification number, date of failure, failure number, failure start and end times, failure description, cause and corrective action, and failure classification.

Participation by utilities was through voluntary agreements before 1982 and the system was plagued by noncompliance. Some of the major sources of inconsistency (see Reference A-13) were:

1. Definition of systems
2. Definition of reportable scope
3. Designation of boundaries between components and ancillary equipment
4. Interpretation of reporting component failure
5. Variations in the skill and training of individuals responsible for reporting data
6. Variations in the amount of effort spent in collecting and correcting the data.

The INPO has been working to correct the inconsistencies and make other changes to improve the system since they took over the NPRDS. The need for better structured maintenance programs and a conveniently available equipment history record is recognized. If they can increase the timeliness of reporting and the percentages of coverage, then trend information becomes important and useful. Use of NPRDS by utilities is encouraged by INPO for component application evaluation, spare parts location, and reliability analysis. The use of NPRDS data as a basis for reliability-centered preventive maintenance is a future goal of INPO.

## **In-Plant Reliability Data System**

The IPRDS is a very comprehensive component data base and, although not included in this comparison, is mentioned here because it may be important in the future for aging and life extension.

In 1972, the Institute of Electrical and Electronic Engineers (IEEE) published Standard 352, which contains a basic methodology necessary to conduct reliability analysis. It was recognized that a data

base was needed to support the IEEE Standard 352 methodology<sup>A-14</sup> and this culminated in 1977 with the publication of IEEE Standard 500.<sup>A-15</sup> This data base contains failure data for generic electrical and electronic equipment, including sensing devices. However, it was recognized by the nuclear community that these components were not the only sources of concern from a plant risk and availability standpoint. Mechanical components were also significant. Because of this interest by the American Society of Mechanical Engineers (ASME), it was decided jointly with IEEE that the future data collection effort should be sponsored cooperatively under the ANSI.

In 1978, a joint committee began collecting failure and repair data from nuclear plant maintenance files. This ongoing data-collection effort

relied on industry volunteers and some financial support was obtained from the USNRC initially to cover administrative costs. Later, the USNRC supported this data base for use in reliability and probability risk assessments (PRA). This data base is unique in that it is a comprehensive collection of data for a limited number of components from a sample population of operating nuclear generating stations. The IPRDS contains population, failure, and repair data for the selected components. But, because of the limited component coverage (i.e., pumps, valves, batteries, invertors, chargers, and diesel generators), it was not included in this comparison of data bases covering systems. These six components were covered from seven plants, eleven units. The IPRDS is not an active system at the present time.

## PLANT DATA SOURCES

Plant data sources from a cooperating utility were evaluated after having extracted what was felt to be the maximum amount of information from external data bases coupled with the knowledge that the data bases contained only a subset of the recorded operating experience. The in-plant data was then compared with the information from the external data sources. The approach used was to understand the data flow for a particular event from the plant report describing the event. Then, trace it to either an LER, NPRDS failure report, or some other document. The hypothesis is that one could then estimate the fraction of events that get reported in external data bases. Through this process, one could get a more complete picture of the history of the component or system and the value of the external data bases.

### Incident Investigation Reports

Nonroutine events in the plant (including those that occurred during the pre-commercial operations phase) are evaluated. This evaluation may result in an IIR that captures the important details related to the event through interviews, analysis of logs, recorder strip charts, and computer printouts. The event may or may not require USNRC notification. Hence, the LERs for the station are a subset of the IIRs. The IIRs were reviewed through April 1985.

Some observations based on sorts of the IIR data base are:

1. Better resolution of information in the coded fields than LERs and NPRDS failure reports
2. Pre-commercial operation events captured
3. Report event frequency relatively constant up to 1984

4. Approximately 5% of the events involve the RPS
5. Coded reporting for LER tracking
6. Infant mortality observable in component failure searches
7. Learning curve observable in frequency of reactor trips.

### Nuclear Maintenance Data Base

Corrective Maintenance (CM) summaries were taken from the Nuclear Maintenance Data Base. It is also known as the Component History Data Base and contains about 50 fields of varying lengths. This is a plant data system that summarizes all CM reports as a one-line summary, work required reference number, and date. The CM request can be obtained when more detail is needed. Any channel or component found deficient during implementation of calibration and testing procedures would have a CM request written to correct the problem. This log is available as computerized printout for data since 1981 and on microfiche for prior years.

The NPRDS failure reports contain a subset of the information in these plant data bases. Currently, there are more than 10,000 components included in the *NPRDS reportable scope* for the station. Even at that, not all components are reportable to the NPRDS data base. As one would expect, the level of detail provided in the plant data sources on equipment history exceeds that of the NPRDS.

Only the computerized summaries on CM were reviewed starting October 23, 1980. Microfilm records for CM before October 23, 1980, were not searched because of manhour and cost limitations.

## APPLICATION OF DATA BASES TO RPS AGING RESEARCH

A significant amount of knowledge and experience, including the use of existing data bases, go into the design, operation, and maintenance of nuclear plant systems. In addition, the operating experience data bases continue to grow as the nuclear plants age. Thus, the various data bases provide an important source of information that can contribute to identifying potential failure modes resulting from time-dependent degradation or service wear.

The NPRDS was used in a recent INEL NPAR task study (Reference A-2) as a data source to aid in the quantification of risk attributable to aging degradation. For the nine LWR systems analyzed, approximately one-fourth of the failure events were categorized as aging, and approximately one-half as other or unknown. The large fraction of the other category reflects the practice of replacing failed components without determining the cause of the failure. The NPRDS data were obtained (3170 failure records) on the behavior of Westinghouse RPS components [which included Engineered Safety Features Actuating System (ESFAS) components] and General Electric RPS components. The components exhibiting the most failures were: signal-processing electronics, transmitters/elements, switches, relays, and power supplies. This compares favorably with the results from the LER and NPE surveys discussed below. Failure events were assigned to one of five failure categories with the results shown in Tables A-1 and A-2. The large percentage of events in the other category is again due to lack of adequate failure analysis to determine the cause. Aging fraction is defined as the ratio of the estimated aging-related failures to the total failures. Note that the failure consequence of RPS components is minimized by redundancy in system design.

An analysis was conducted on 1,402 LER events reported on the reactor trip system (RTS) for the period 1976 to 1981. The majority of component

**Table A-1. RPS failure category fractions from NPRDS**

Failure Category	Fraction
Design and installation	0.141
Aging	0.233
Test and maintenance	0.060
Human related	0.008
Other	0.556

**Table A-2. RPS system effect fractions from NPRDS**

System Effect	Fraction
Loss of system function	0.002
Degraded system operation	0.167
Loss of redundancy	0.170
Loss of subsystem/channel	0.393
System function unaffected	0.268

failures were transmitters/sensors, signal processing electronics, and power supplies, with the majority of failure mechanisms attributable to the categories of drift, piece part failure, unknown, and personnel maintenance. Sixty-three percent of the failures were detected through testing and thirty-four percent were detected through normal operations. The evaluation of plant data yielded comparable results. The gross failure category results were: 56% were age related (time in service) and 25% due to frequency of use (demand).

The NPE search covered 2,487 events over 25 years of RPS experience for all U.S. nuclear plants (see Reference A-2). The components with the largest number of failures were: signal processing electronics, relays/breakers, transmitters/sensors, and sensing lines/instrument piping. The dominant causes were: operator/maintenance error, instrumentation and control (I&C) component failure, design/construction error, mechanical wear, and drift. There is some variation in the results of the searches on LERs and NPE due to differences in the period of time considered, system definitions and boundaries [i.e., RPS vs. reactor trip system (RTS)], and the data base structure. Overall, 50.3% of the NPE data base failures were identified as potentially aging related. *Potentially aging related* means that further analysis may be required to identify root cause.

The RPS components are ranked in order of frequency of failure occurrence in Table A-3 for each of the data systems. While the same components occur among the top six categories, the order of occurrence varies somewhat reflecting the subset of data that comprises each data base. The causes for the events, however, show a much larger variation, as shown in Table A-4.

**Table A-3. RPS component categories ranked by event report frequency**

<u>RPS Components</u>	<u>LER</u>	<u>NPE</u>	<u>NPRDS</u>	<u>IIR</u>	<u>CM</u>
Sensors/transmitters	1	3	2	2	1
Signal processing electronics	2	1	1	1	2
Relays/breakers	3	2	4	5	6
Power supplies	4	4	5	3	3
Cables, connectors, terminals	5	5	6	6	5
Switches	6	6	3	4	4

**Table A-4. RPS failure cause categories ranked by event report frequency**

<u>Cause Categories</u>	<u>LER</u>	<u>NPE</u>	<u>IIR<sup>a</sup></u>	<u>CM<sup>b</sup></u>	<u>NPRDS<sup>c</sup></u>
Drift	1	5	—	2	4
Part failure	2	2	—	1	1
Unknown	3	7 <sup>d</sup>	3	10	—
Operations/maintenance error	4	1	5	—	—
Electrical malfunction	5	6	—	—	—

a. Procedure No. 2, environment No. 4.

b. Out of calibration No. 3, procedure error No. 4 and connectors, terminals and leaks No. 5.

c. NPRDS is primarily a component failure data base (out of calibration No. 2, loose connection No. 3).

d. Other/miscellaneous.

A PWR was selected to determine the number of RPS events reported by each of the data sources. A chronological listing of RPS events for this PWR is presented in Table A-5, which combines the information from three generic data bases and two plant data systems. A direct comparison of the data bases over the entire period for which information is available is difficult because each was set up for a specific purpose and do not cover the same subset of events. Periods during which data were not available are marked on Table A-5 as *ND* for no data reported. The source(s) for each event is noted in Table 5 with an X in the column if the data base contained the item. Minor maintenance items (such

as pens not inking, painting, or changing filters) were deleted from the CM list, leaving 31 items covering component failures, component replacement, calibration, or faults affecting system operation. Table A-5 covers only RPS I&C events. The engineered safeguard system and scram breakers are not included.

Table A-6 presents a summary of the data coverage over a selected time interval, October 23, 1980, through April 25, 1985, for which there is information available and analyzed from all five data bases. The percent of the component failure events included in each of the five data bases during this period are listed. The data from both the in-plant

### Acronyms for Table A-5

FW	feedwater	PRESS	pressure
RTD	Resistance temperature device	CAL	calibration
RPS	Reactor Protection System	inst	instrument
SW	switch	AUX	auxiliary
Ch	channel	diff	differential
TRANS	transmitter	AMP	amplifier
Rx	reactor	POT	potentiometer
$\phi/F$	Flux/flow	Temp	temperature
B/S	bistable	inv	inverter
RO	reportable occurrence	pos	positive
Repl	replaced	neg	negative
Rep	repair	Pwr	power
RC	reactor coolant	SUP	supply
P.S.	Power supply	ND	no data reported
		X	data base contains this item

**Table A-5. Chronological list of RPS events from all data sources for a selected PWR**

<u>Date</u>	<u>Description of Problem</u>	<u>CM</u>	<u>IIR</u>	<u>NPE</u>	<u>NPRDS</u>	<u>LER</u>	<u>NOTES</u>
10/23/80	Reactor trip module repaired'	X	—	—	ND <sup>3</sup>	—	—
03/10/81	Ch tripped for no reason	X	—	—	ND	—	1
03/24/81	Press trans out of cal (Ro 81-6) inst. drift	X	X	—	ND	X	—
08/81	RPS Inst. string errors non-conservative	X	X	X	ND	—	1, 2
08/05/81	Rep Pump monitor Ch C	X	—	—	ND	—	—
09/11/81	Repl AUX power system CH C	X	—	—	ND	—	—
11/25/81	Ch B scaled diff amp failed (O/F B/S out of limits)	X	X	X	ND	X	—
12/02/81	Ch C contact monitor will not trip (logic board failed)	X	X	X	ND	X	—
12/14/81	Unit runback to 60% due to RC flow transmitter failing low. Op stabilized unit. Recovered to 100% once CH. was switched	X	X	—	ND	—	—
02/10/82	Ch B temp bridge failed	X	X	X	X	X	—
11/14/82	Ch A placed in trip bypass with (B/S-procedure deficiency)	X	X	X	—	X	1
01/31/83	Rep pot on top linear amp Ch D	X	—	—	—	—	—
02/25/83	Pump monitor test procedure deficient (tech spec violation RO-287-83/2)	X	X	X	—	X	1
06/12/83	Ch D flow reading low-replace amp in transmitter (Ch D trip)	X	—	—	X	—	—
12/26/83	Ch B temp bridge out of cal	X	X	—	X	X	—
02/16/84	RC transmitter failed-Rx trip	X	—	X	—	X	—
03/29/84	Terminal block cracked and broken	X	—	—	—	—	—
06/07/84	Investigate reason for reactor trip	X	X	—	—	X	1
08/16/84	Rep Ch D temp	X	—	—	—	—	1
08/20/84	Ch C tripped and low flow alarm	X	—	—	X	—	—
10/26/84	Rep Ch D O/F tripped	X	—	—	—	—	1

**Table A-5. (continued)**

<u>Date</u>	<u>Description of Problem</u>	<u>CM</u>	<u>IIR</u>	<u>NPE</u>	<u>NPRDS</u>	<u>LER</u>	<u>NOTES</u>
11/03/84	Ch A flow cajon jacket leaked	X	—	—	X	—	—
11/21/84	Erratic neutron error inv/rep	X	—	—	—	—	—
11/23/84	Ch D temp cal	X	—	—	—	—	1
01/02/85	Ch C P.S. drift-repl monitor aux power supply	X	—	—	X	—	—
02/24/85	P.S. connection failure	X	—	—	X	—	—
03/12/85	Rep capacitors pos & neg pwr sup.	X	—	—	—	—	—
03/17/85	Contact buffers 3B will not reset	X	—	—	—	—	1
03/31/85	RTD failure (normal wear) repl 11/19/85	X	—	—	X	—	—
04/04/85	Changed aux relay (A1-4-14)	X	—	—	—	—	—
04/25/85	Rep pres SW 419, 3B FW SW will not open	X	—	—	—	—	—

Note 1: Items not aging related, due to procedure error or other causes. Human errors and other obviously non-aging events not included in the table.

Note 2: Common-mode problem (e.g., another component failed causing RPS degradation when RPS working okay, power failure or moisture affecting more than one component, or grounding problem.)

Note 3: ND indicates data not reported.

**Table A-6. Percentage of events covered by each data base for period of time data was available and reviewed**

Data Base	Period Covered		Percent of Events Covered <sup>a</sup>
	From	To	
CM	10/23/80	- 04/25/85	100 <sup>b</sup>
IIR	10/23/80	- 04/25/85	32
NPE	10/23/80	- 04/25/85	23
NPRDS	02/10/82	- 04/25/85	36
LERs	10/23/80 through 1983		47
LERs	1/1/84 <sup>c</sup> through 04/25/85		6

a. Reference is corrective maintenance records.

b. Some procedural changes may not have CM requests written for periods before that reviewed. Thus, the overall percentage covered by CM may be less than 100.

c. Rule change on LER reporting requirements.

records and the generic data bases are specific to the one plant under consideration.

The following observations are made from the data for the plant studied:

1. Aging-related events are defined as those events that are the consequence of expected time dependent wear (or degradation). Also, included are those events classified as due to frequency of use (or demand), such as breaker trips. Examples of *nonaging-related events* would be design error, personnel error, or procedure error. Out of the 31 events listed, 22 are potentially aging related. However, further analysis would be required to determine the root cause of many of these events.
2. Due to redundancy of RPS channels, few system failures are observed. When system failures do occur, they are usually the result of common mode failures of human error.
3. Because of reporting requirements, some information may not be known at the time the report is filed. All information may not find its way into the reporting system because of the above or data truncation to satisfy reporting requirements.
4. The plant CM records were used as the standard in Table 5 because they covered all the events found and were the most complete source of information. Only the computerized summaries on CM were reviewed starting October 23, 1980. Microfilm records for CM before October 23, 1980, were not searched because of manhour and cost limitations. The maintenance records also show that many potential problems are fixed before major system or channel failures occur. Thus, maintenance records also reflect the incipient failures to some extent.
5. IIRs are company proprietary and cover reportable events such as technical specification violations. About 25% of the RPS events reported in IIRs affected plant operation. Only 10% of the events from all sources affected plant operation. In the other 90%, only one of the RPS channels was affected and the plant continued to operate on redundant channels. The IIRs covered 32% of the events found in the CM data base.
6. From January 1, 1984, to April 25, 1985, after the reporting rules for LERs were

changed (items reported under 10 CFR 50.73), there were a total of 16 events of which at least 10 involved failed components. During this period two LERs and five NPRDS events were reported. When compared with the information in the CM data base, 47% of the CM events were found in LERs before 1984 and 6% after January 1, 1984.

7. The NPRDS data base contains primarily component failures. Common mode and human error events causing system or channel failures are not included in this data base unless a system component failed. Catastrophic component failures

and degradation of components that result in limits being exceeded are reported, whereas incipient failures are not. An example of incipient failure would be replacing capacitors in a power supply before limits are exceeded or it fails. About 36% of the CM events were found in the NPRDS data base.

8. The NPE relies on information in the public domain. With the change in LER reporting in 1984, the NPE also has fewer events because LERs were one of the major sources of NPE data. For the time period reviewed for this one plant, 23% of the CM events were found in the NPE data base.

## CONCLUSIONS

The pilot RPS study was limited to the practices of one utility and information sources were identified for a representative PWR power plant.

The identification of aging and service wear effects derived from the analysis of plant external information sources requires an understanding of the purpose and limitations of the source. The purpose of the LER is to provide information to the USNRC on unusual events, not to provide an engineering data base for statistical analysis. Thus, caution should be used in inferences made from that analysis. The 1984 revision to the LER reporting requirements has greatly reduced the number of events being reported. Because of voluntary participation and the variation in the interpretation of reportable scope and system/component boundaries, the NPRDS also may not represent the total failure event histories for the systems and components of interest.

With the addition of plant records, a more complete system history can be assembled to gain an understanding of the successes as well as failures of the system, the maintenance and surveillance performed that may affect the failure probability and estimated life, and the periods of time spent in steady-state and transient conditions. However, it still may not always be possible to characterize the history of certain degradations due to environmental causes because measurements of local conditions are not made.

The older plants may not have all the records required for a complete analysis. Also, records may have been acquired but stored in a form that either requires a significant amount of effort for analysis; or degraded with time making them unusable. Some information may not be available because a failure analysis was not performed, the component is inaccessible or resides in a high radiation environment so that it receives little or no surveillance and maintenance, there is no requirement to either acquire or retain the data, etc.

The plant data from the representative plant in the form of CM summaries and IIRs provide the same general type of information although in much greater detail than the summarized reports in LERs, NPE, or NPRDS. Also, many more events that could be aging related are found in the plant records than in the other data bases. For example, the plant CM summary records listed about 31 work requests for the RPS over a 4-1/2-year period. The LERs had 9 events and NPE had 7 events for the same 4-1/2-year period. The NPRDS listed 8 failures from February 10, 1982, to April 25, 1985, and CM had 22 items for this same period.

The root cause of equipment failure information contained in the generic data bases is limited and inconsistent. By design, they report failure effects on systems and safety functions and lack detail on specific failure mechanisms, contributing causes, or repair actions.

The RPS is a good example of controlling aging through the use of design, inspection, surveillance, monitoring, and CM with the aid of historical data bases. Design is included because of redundancy and independence. By identifying the frequently failing components and applying monthly maintenance, the system is in a continuous state of renewal, with the exception of cables in containment.

The answers to questions posed in the *Introduction* section are given below with the question repeated for convenience of the reader.

**Question:** Which, if any, of the generic data bases contain a representative sample of nuclear power plant safety systems problems and failures due to aging?

**Findings:** The identification of aging and service wear effects derived from analysis of the generic data bases requires an understanding of the purpose and limitations of the source. The purpose of the LER is to provide information to the USNRC on unusual events, not to provide an engineering data base for statistical analysis; thus, caution should be used in inferences from that analysis. Although 47% of the events (using maintenance records as reference) were covered, the root cause could not always be determined. The 1984 revision to LER reporting requirements has greatly reduced the number of events being reported externally. Thus, since January 1, 1984, the LERs do not contain a representative sample of aging-related failures.

Because of the voluntary participation and variation in the interpretation of reportable scope and system boundaries, the NPRDS may not represent the total failure event histories for the

systems and components of interest. Since 1982 when INPO took over the NPRDS, 36% of the failures have been reported as compared to the plant maintenance records for the one plant studied. The NPE data base relies heavily on LER input as well as other public domain material; thus, the change in LER reporting requirements has also affected NPE. Because this study is based on only one plant with maintenance records as a reference, the conclusions apply only to the one plant. The implications are that the generic data bases fall short of being representative of all aging related failures.

**Question:** How well do the data bases agree on the frequency and cause of the component failures?

**Findings:** The relative frequency of failure for the top six components was ranked for each data base in Table A-3. While the same six components failed frequently in each data base, the order of the relative frequency of failure of the top six varied. In retrospect, this should be expected because each data base contains a subset of the total number of events. An even greater variance is noted in Table A-4 where cause categories are ranked. The large spread in cause category ranking is due to a number of factors including: number of cause categories and how they are combined, purpose of the data base, subset of events in the data base, and even built-in biases. For example, the maintenance data base had no category for maintenance personnel error. So the answer is that the data bases generally agree on what items are among the top six in frequency of occurrence, but cause categories have a wide variation for the reasons discussed above.

**Question:** Is it necessary to examine plant records (go to the nuclear plants) to get the trend information needed for aging research?

**Findings:** All the data bases provide failure data. However, trend data for a particular piece of equipment is more difficult to obtain from most data bases because of the time element. A baseline is needed from which to observe a change and, thus, establish a trend. Condition monitoring has been one means used to obtain trend information. However, trend information, except for major components, is probably not available at most utilities. In the future, data bases built on computer monitoring may provide trend data, but it is not yet available at most plants.

**Question:** What additional information needs exist that are not satisfied by current data sources?

**Findings:** The current data sources contain historical data on component failures or events. Trend data is needed on selected higher risk safety-related components. Condition monitoring is one way to obtain such data. The risk assessment associated with aging also needs trend data. One way to obtain trend data is for utilities to set up computer systems to collect trend data with possible tie-in to a central data collection facility operated by EPRI, INPO, USNRC, or some national group.

## REFERENCES

- A-1. *Nuclear Plant Aging Research (NPAR) Program Plan*, NUREG-1144, U.S. Nuclear Regulatory Commission, 1985.
- A-2. B. M. Meale and D. G. Satterwhite, *An Aging Failure Survey of Light Water Reactor Safety Systems and Components*, NUREG/CR-4747, EGG-2473, Idaho National Engineering Laboratory, July 1987.
- A-3. C. F. Miller et al., *Data Summaries of Licensee Event Reports of Selected Instrumentation and Control Components at U.S. Commercial Nuclear Power Plants*, NUREG/CR-1740, Idaho National Engineering Laboratory, 1981.
- A-4. G. A. Murphy et al., *Survey of Operating Experience from LERs to Identify Aging Trends*, NUREG/CR-3543, Oak Ridge National Laboratory, 1984.
- A-5. E. J. Siskin et al., *Analysis of Utility Industry Data Systems*, EPRI NP-1064, April 1979.
- A-6. M. K. Comer et al., *Human Reliability Data Bank for Nuclear Power Plant Operations*, NUREG/CR-2744/2, February 1983.
- A-7. R. H. Coppe and G. I. Arnst, *Consolidating Power Plant Data Systems*, EPRI NP-836 (prepared by S. M. Stoller Corporation), July 1978.
- A-8. Code of Federal Regulations, Title 10, Part 50.72.
- A-9. *Reporting of Operating Information - Appendix A, Technical Specifications*, U.S. Nuclear Regulatory Commission, Regulatory Guide 1.16.
- A-10. U.S. Nuclear Regulatory Commission, *Instructions for Preparation of Data Entry Sheets for Licensee Event Reports*, NUREG-1061.
- A-11. *Title 10, Part 50.73 of the Code of Federal Regulations*, Federal Register (Vol. 48, No. 144), July 26, 1983.
- A-12. U.S. Nuclear Regulatory Commission, *Licensee Event Report System - Description of Systems and Guidelines for Reporting*, NUREG-1022.
- A-13. J. P. Drago, R. J. Borkowski, D. H. Pike, *The In-Plant Reliability Data Base for Nuclear Power Plant Components: Data Collection and Methodology Report*, NUREG/CR-2641, Oak Ridge National Laboratory, July 1982.
- A-14. *Guide for General Principles of Reliability Analysis of Nuclear Power Generating Station Protection Systems*, IEEE Standard 352-1975, ANSI/IEEE, Reaffirmed 1980.
- A-15. *Guide to the Collection and Presentation of Electrical, Electronic, and Sensing Component Reliability Data for Nuclear-Power Generating Stations*, IEEE Standard 500-1977.

**APPENDIX B**

**ACTUATED PART OF RTS**  
**(Scram Breakers and Associated Circuitry)**

**APPENDIX B**  
**ACTUATED PART OF RTS**  
**(Scram Breakers and Associated Circuitry)**

**CONTENTS**

INTRODUCTION .....	B-3
ACTUATED RTS COMPONENTS .....	B-7
Relay .....	B-7
Contactor .....	B-7
Circuit Breaker .....	B-7
Undervoltage Trip Attachment .....	B-7
Shunt Trip Attachment .....	B-7
B&W SCRAM SYSTEM .....	B-8
TYPES OF BREAKERS .....	B-10
OPERATING EXPERIENCE .....	B-11
COMPONENT AGING RESEARCH .....	B-12
GENERIC IMPLICATIONS FOR THE RTS .....	B-13
CONCLUSIONS .....	B-14
REFERENCES .....	B-15

**FIGURES**

B-1. Babcock & Wilcox Reactor Trip System .....	B-6
B-2. Reactor Trip Modules Arrangement .....	B-9

**TABLE**

B-1. RTS Design Features Comparison .....	B-7
---	-----

## **APPENDIX B**

### **ACTUATED PART OF RTS (Scram Breakers and Associated Circuitry)**

#### **INTRODUCTION**

At commercial nuclear plants there are four basic reactor trip designs used to initiate reactor shutdown. These are the designs from the four NSSS vendors: Westinghouse (W), Combustion Engineering (CE), Babcock & Wilcox (B&W), and General Electric (GE). For the actuated part of the RTS, a description of the B&W scram breaker system and associated circuitry

will be given. The other vendors have similar systems with some differences as indicated in Table B-1. Even the same vendor has differences between earlier and later system models. The one described is shown in Figure B-1 and is used on seven of the B&W plants. A brief discussion of the commonly used components in the actuated part of the RTS will be given first.

**Table B-1. RTS design features comparison**

Reactor Trip System	Method Used to Accomplish Reactor Trip	Actuating Devices		Number of Rod Groups <sup>a</sup>	Trip System Configuration	Automatic Reactor Trip Logic	Manual Reactor Trip Capability
		Automatic	Manual				
Westinghouse	Interrupt power to control rod drive holding mechanisms by tripping open the reactor trip breakers.	Undervoltage trip attachments (one per breaker).	Undervoltage and shunt trip attachments (one each per breaker). The shunt attachment is nonsafety related.	1	2 series breakers supply power to all rods. Each breaker has a parallel bypass breaker for testing purposes.	2-out-of-4 (typically)	2 switches Each switch actuates both reactor trip breakers.
Combustion Engineering	Interrupt power to control rod drive holding mechanisms by tripping open the reactor trip breakers.	Undervoltage and shunt trip attachments (one each per breaker).	Undervoltage and shunt trip attachments (one each per breaker).	2	8 breakers. Each group is provided power via 2 parallel paths, each path containing two series breakers.	2-out-of-4	4 switches 4 combinations of two switches will cause a full reactor trip.
Combustion Engineering (Fort Calhoun and Palisades)	Interrupt power to control rod clutch mechanisms by opening contacts.	Contactors	Contactors	2	4 contactors provide power to both groups.	2-out-of-4	2 switches (one on the main control board), either of which will cause a trip.

**Table B-1. (continued)**

Reactor Trip System	Method Used to Accomplish Reactor Trip	Actuating Devices		Number of Rod Groups <sup>a</sup>	Trip System Configuration	Automatic Reactor Trip Logic	Manual Reactor Trip Capability
		Automatic	Manual				
Babcock & Wilcox Design for seven plants	Interrupt power to control rod drive holding mechanisms by opening reactor trip breakers. Interrupting SCR control power will also trip the regulating rods.	Undervoltage trip attachments and SCR control power relays (non-safety-related) for regulating rods.	Undervoltage trip attachments and SCR control power relays (nonsafety-related for regulating rods.	6 (2 safety groups and 4 regulating groups).	2 upstream ac breakers provide power to all 6 groups. 4 two-pole dc breakers downstream provide power to the 2 safety groups. Power to the regulating groups is by SCRs downstream of the ac breakers.	2-out-of-4	One switch
Babcock & Wilcox (Davis-Besse Design)	Interrupt power to control rod drive holding mechanisms by opening reactor trip breakers. Interrupting SCR control power will also trip all rods.	Undervoltage trip attachments and SCR control power relays (nonsafety-related).	Undervoltage trip attachments and SCR control power relays (non-safety-related).	8 (4 safety groups and 4 regulating groups).	4 breakers; two parallel paths, each with 2 series breakers. Either path will provide power to all 8 rod groups through SCRs.	2-out-of-4	Two switches (either will cause a full reactor trip).
General Electric	Interrupt power to scram pilot valve solenoids by opening contacts. The pilot valve solenoids vent air from scram valves which direct water pressure to insert rods.	Contactors	Contactors or manual trip switch contacts, depending on the design.	4	Each control rod has two scram pilot valve solenoids, both of which must be de-energized for that rod to insert 8 contactors provide power to the solenoids.	1-out-of-2 (taken twice)	4 switches 4 combinations of two switches will cause a full reactor trip.

B-5

a. The number of rod groups listed here is based on the number of groups having different power distribution paths, not on the number of groups used for reactivity control.

Note: Table based on Table 3-1, Reference B-1.



## ACTUATED RTS COMPONENTS

The components associated with the scram breakers include relays, contactors, circuit breakers, circuit breaker undervoltage trip attachment, and circuit breaker shunt trip attachment. This description is general and it should be recognized that there are similar components that may operate differently from those described.

### Relay

A relay is an electrically operated switch and is generally used in logic circuits. A relay consists of an electromagnet which, when energized, attracts a metal lever called an armature and pulls it against the force of a spring. The armature can occupy one of two positions: (1) the electromagnet is energized and, (2) the electromagnet is de-energized. A number of switches may be activated by the armature. The switches are insulated from the armature and may be either normally open or normally closed depending on the particular assembly. Some common relay failure modes related to aging include: sticking of the armature due to wear, corrosion, dirt, or other foreign material; open or short circuits in the coil of the electromagnet; or contact degradation due to corrosion or dirt. Types of failures in relays is covered in Reference B-2

### Contactors

Contactors are capable of carrying larger currents than relays and are generally used in power circuits for small motors. Otherwise, they are similar to relays with a coil, armature, and contacts. The same type of relay failure modes also apply to contactors. Contactors are used on GE plant trip systems.

### Circuit Breaker

A circuit breaker is also a switch, but is designed to interrupt large currents such as those that might exist in a circuit with power cables to a large motor. This type of circuit breaker includes design features which contain, suppress, or dissipate arcs which may occur when the contacts interrupt a large current. Circuit breakers used in reactor trip systems

close against a strong spring force and are latched in the closed position. Tripping (opening) is accomplished by releasing the latch mechanism and allowing the springs to rapidly force the breaker contacts apart interrupting the current through the contacts. The latch may be released either by a mechanical linkage or by an electromechanical device with remote control. The mechanical linkage is used for manual tripping of the breaker. When the electromechanical device of the scram breaker is actuated, it releases the latch, thus opening the contacts and interrupting power to the control rod drive mechanism (CRDM).

### Undervoltage Trip Attachment

The undervoltage trip attachment is essentially a solenoid. It consists of an electromagnet which, when energized, attracts a plunger or lever against a spring. The plunger or rod is connected through mechanical linkage to the circuit breaker latch mechanism. When the electromagnet is de-energized, the force of the spring releases the latch mechanism causing the circuit breaker to open. The circuit breaker should remain closed whenever the electromagnet is energized. This means the coil must be designed not to overheat when energized for long periods of time.

### Shunt Trip Attachment

The shunt trip attachment is similar to the undervoltage trip attachment except that the circuit breaker remains closed when it is de-energized. Energizing the shunt trip attachment results in opening the circuit breaker. The shunt trip devices are simpler than the undervoltage devices in that they are energized for only a short period of time before the circuit breaker latch mechanism releases.

Outside the nuclear industry the shunt trip attachments are normally used rather than the undervoltage trip attachment. The undervoltage trip attachments are used in the nuclear industry in order to satisfy the fail safe design criteria, (General design criteria 23 of 10 CFR 50 Appendix A).

## B&W SCRAM SYSTEM

The system described is representative of those used at seven of the B&W plants. Typically, about half of the 70 control rods are used for reactor trips. These are called the safety rods. The other half, called regulating rods, are used for both reactor shutdown and control of reactor power level. (See Figure B-1.) After a reactor trip, the operator would have time to insert the remaining control rods or inject boron. The safety rods are divided into four groups of approximately eight to twelve rods each. The regulating rods have a similar arrangement but differ from the safety rods in the manner of power distribution and methods used to interrupt the power.

Power is supplied to each group of safety rods from two sources, a main supply and a secondary supply. In each of the supply lines there is an ac breaker which will interrupt power to both the safety rods and the regulating rods. Each of the two supply sources goes to a holding power supply. The four dc outputs from the holding power supply go through dc breakers to the safety rod groups. To interrupt power to a given group of safety rods requires that either the ac or the dc breaker in each of the two power sources (main supply and secondary supply) open. Each dc trip breaker in the B&W design is a two-pole device which supplies power to two safety rod groups.

Power to the regulating rod groups is provided by two separate sets of silicone control rectifiers (SCRs). Any combination of trip signals or component failures which interrupts power to both sets of SCRs will cause these rods to insert. Output from trip modules C and D goes to the relays which control power to the SCRs. The main interest here, however, is the trip breakers and the safety rod group.

The reactor trip module outputs (A, B, C, and D) actuate the reactor trip breakers and SCR control power relays as follows. The output from trip modules A and B actuate the two ac trip breakers. The output from module C actuates the two two-pole dc trip breakers downstream from the ac breaker actuated by trip module A and the SCR power control relays labeled E. The D trip module output actuates the other dc trip breakers and the SCR control relays labeled F. The combinations of reactor trip module outputs which will cause a full reactor trip (all rods dropped) are AB, AD, BC, or CD. For example, AB means the output A and B. This is logically equivalent to (A or C) and (B or D).

The arrangement for the reactor trip modules is shown in Figure B-2. The four trip modules, A, B, C, and D correspond to the four reactor trip strings discussed in the RPS report. Each of the four channels can also be tripped manually from the control room by one push-button switch.

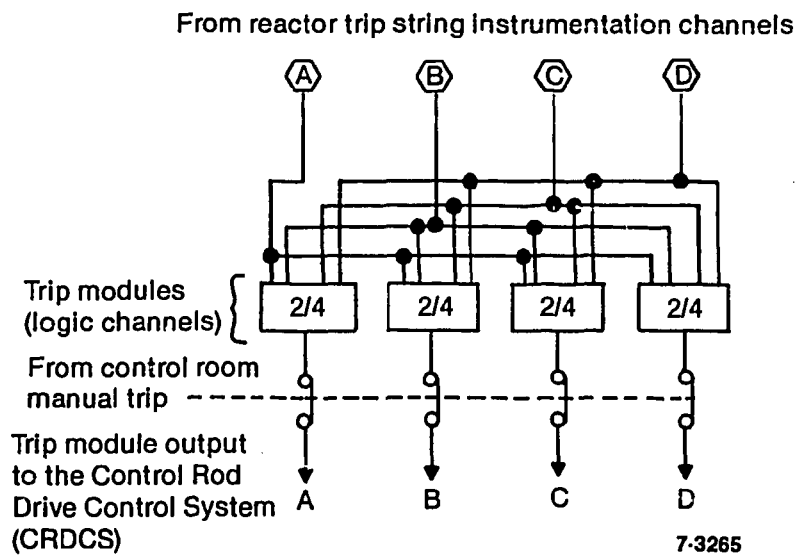

Figure B-2. Reactor Trip Modules Arrangement.

## TYPES OF BREAKERS

Most of the PWRs employ breakers in their trip systems. The G.E. BWRs use contactors instead of breakers. The Westinghouse plants use the Westinghouse DB-50 and the DS-416 circuit break-

ers. The B&W and CE plants (except Palisades and Ft. Calhoun) use the General Electric AK-2 circuit breaker. Palisades and Ft. Calhoun use a contactor arrangement in their trip systems.

## OPERATING EXPERIENCE

All three types of breakers have experienced failures, most of which involved the undervoltage trip relay attachment. Causes of failures in the DB-50 series breakers were attributed to dirt, broken parts, and mechanical binding of the undervoltage trip attachment. Wear and lack of lubrication were also contributing factors. A few were failures of the electrical coils and one was attributed to the undervoltage trip attachment not exerting enough force.<sup>B-3</sup> The AK-2 breaker failure causes were attributed to either binding within the linkage mechanism of the undervoltage trip attachment and trip shaft or out-of-adjustment conditions in the linkage mechanisms.<sup>B-4</sup> Inadequate preventive maintenance programs were also a contributing factor.

At CE plants a more diverse tripping arrangement is used in which both the shunt trip and the

undervoltage trip attachments operate simultaneously to open the breaker. A failure in either device might not be recognized during a scram. The periodic tests used at CE plants should verify the trip function of the undervoltage attachment independent of the shunt trip attachment.<sup>B-5</sup>

Problems with the DS-416 breaker were related to design or quality assurance. The DS-416 is a newer design and is used on about 25 plants. The most recent failure of the DS-16 occurred on July 2, 1987. This failure probably did not have generic implications, but indicated that an enhanced maintenance program should be considered.<sup>B-6</sup> The LER data<sup>B-7</sup> summaries and the IE bulletins (References B-4, B-5, and B-8 through B-17) cover the failures on all three types of breakers in more detail.

## COMPONENT AGING RESEARCH

The Franklin Research Laboratory (FRL) performed testing and evaluation on the undervoltage trip attachments of several breakers from the Salem Nuclear Plant (Westinghouse DB-50) (references B-1, B-2). They identified two possible failure modes. The first failure mode apparently occurs when the latch-to-latch pin binding prevents unlatching of the undervoltage trip attachment. When the undervoltage attachment was lubricated, no further failure occurred. The second possible failure mode was recognized from inspection of the undervoltage trip

device. This was increased friction between the latch spring and latch due to age and lack of lubrication. Contributing factors to these failure modes were dirt and dust, lack of lubrication, nicking of the latch surfaces caused by repeated operations of the breaker, and wear. These contributors appeared to be accumulative with no one main cause. The task force investigating the Salem event also concluded that the failure of the undervoltage device was accelerated due to improper lubrication and maintenance.

## GENERIC IMPLICATIONS FOR THE RTS

The types of failures experienced with scram breakers are of the type generally considered to be candidates for common mode failures. The undervoltage trip attachments are complicated and require careful attention to maintenance, lubrication, and adjustment. There is potential in all the NSSS designs for common cause failure of identical or similar components to result in a failure to trip. This is a failure which is sometimes referred to as the unsafe direction. A component failure which causes the reactor to trip would be

referred to as the safe direction. Thus, the different component failure modes have different system effects. The aging related failures experienced with the undervoltage trip devices have been preventing trips whereas the human errors associated with testing and maintenance have tended to increase false trips. The false trips will tend to decrease the life of the breakers and associated components. Breakers have a finite life in terms of cycles. For example, Westinghouse rates the life of the undervoltage trip device at 1250 cycles (Reference B-1).

## CONCLUSIONS

Improper maintenance, lubrication, and aging has contributed to the failure of electrical coils and the weakening of springs. The actuated part of a B&W system RTS was discussed. At least two components must fail before the system will fail. Most of the problems with the scram breakers in PWRs have been with the undervoltage trip device. The undervoltage trip device failures have occurred with all three types of breakers in use at nuclear plants. Aging has contributed to the wear and sticking of release mechanisms. Corrective measures have included enhanced maintenance,

with more attention given to periodic lubrication and adjustment of breakers.

System failure modes due to component failures can be either in a direction to cause a trip (a safe direction) or to prevent a trip (an unsafe direction). The undervoltage trip device failures have tended to be in the unsafe direction. Since the undervoltage trip device sticking problem could affect any of the breakers, there is potential for a common mode failure in two devices which could then prevent the reactor from tripping.

## REFERENCES

- B-1. *Generic Implications of ATWS Events at the Salem Nuclear Power Plant, 1*, NUREG-1000, April 1983.
- B-2. G. J. Toman, V. P. Bacanskas, T. A. Shook, and C. C. Ladlow, *The Interactive Effects of Relay and Circuit Breaker Aging in a Safety-Related System*, NUREG/CR-4715, July 1986.
- B-3. *Draft to Regional Offices*, IEB 71-2, December 9, 1971.
- B-4. *Failures of GE Type Circuit Breaker in Safety Related System*, Bulletin 79-09, April 17, 1979.
- B-5. *Inadequate Periodic Test Procedure of PWR Protection System*, Circular 81-12, July 22, 1981.
- B-6. "Investigators Doubt Generic Implications In McGuire-2 RTB Failure," *Inside NRC*, August 3, 1987.
- B-7. S. R. Brown, *Data Summaries of Licensee Event Reports of Protective Relays and Circuit Breakers at U.S. Commercial Power Plants, January 1, 1976 to December 31, 1983 (Draft)*, NUREG/CR-4126, EG&G Idaho.
- B-8. *Reactor Trip Breaker, Westinghouse Model DS-416, Failed to Open on Manual Initiation from the Control Room*, NRC Information Notice No. 87-35.
- B-9. *Potential Problems in Westinghouse Molded Case Circuit Breakers Equipped With a Shunt Trip*, Information Notice 86-62, July 31, 1986.
- B-10. *Westinghouse Type DS Circuit Breakers, Potential Failure of Electric Closing Feature Because of Broken Spring Release Latch Lever*, Information Notice 86-93, December 6, 1985.
- B-11. *Undervoltage Trip Attachments of Westinghouse DB-50 Type Reactor Trip Breakers*, Bulletin 85-02, November 5, 1985.
- B-12. *Failure of a General Electric Type AK-2-25 Reactor Trip Breaker*, Information Notice 85-58, July 17, 1985 and Supplement 1, November 19, 1985.
- B-13. *Reactor Trip Breaker Malfunctions (Undervoltage Trip Devices on GE Type AK-2-25 Breakers)*, Information Notice No. 83-76, November 2, 1983.
- B-14. *Required Actions Based on Generic Implications of Salem ATWS Events*. Generic Letter 83-28, July 8, 1983.
- B-15. *Failures of the Undervoltage Trip Function of Reactor Trip System Breakers*, Information Notice 83-18, April 1, 1983.
- B-16. *Failure of the Undervoltage Trip Function of Reactor Trip Breakers*, Bulletin 83-04, March 11, 1983.
- B-17. *Failure of Reactor Trip Breakers (Westinghouse DR-50) to Open on Automatic Trip Signal*, Bulletin 83-01, February 25, 1983.

**APPENDIX C**  
**RELAY PROBLEMS IN THE RPS**

**APPENDIX C**  
**RELAY PROBLEMS IN THE RPS**  
**CONTENTS**

OPERATING EXPERIENCE .....	C-3
CONCLUSIONS .....	C-5
REFERENCES .....	C-6

**TABLES**

C-1. Cause of Relay Failures in the RPS .....	C-3
C-2. Relay Failure Events by Type Reported in LERs .....	C-3

## APPENDIX C

### RELAY PROBLEMS IN THE RPS

#### OPERATING EXPERIENCE

Based on NPE data for all U.S. operating nuclear plants, 6.2% of component failures in RPSs were attributed to relays. The NPRDS data for Westinghouse plants indicated 10.9% of the component failures were associated with relays and 22.6% of these were attributed to aging. Because of redundancy in the RPS, total loss of system function occurred only 0.7% of the time due to any one component failure.

The cause of relay failures in the RPS from NPE data is shown in Table C-1. The data cover 423 events from 1975 to June 1987.<sup>C-1</sup>

A breakdown on relay failure causes from LERs for the period from January 1975 to July 1985 for all types of relays is shown in Table C-2. This data is taken from Reference C-2 and C-3.

**Table C-1. Cause of relay failures in the RPS**

Event Cause	Percent
Operator/maintenance error	17
Design/installation error	14
Short/arcing/ground	14
Heat/overload	6
Relay sticking/stuck	6
Electric power failure	5
Mech disability	4
Blockage/fouling	3
Wearout	2
Fastener broken/damaged	2
Other, unknown	<u>27</u>
	100

**Table C-2. Relay failure events by type reported in LERS**

Event Cause	Percent
Set Point Drift	20.5
Short or Open Coil	10.5
Binding	9.9
Failed Contact	7.6
Failed Electrical Parts other than Coil or Contacts	6.5
Dirty Contact	4.3
Human Factors	4.3
Dirty Relay (not Contacts)	3.2
End of Life	2.6
Design Error	2.4
Contact Alignment	1.8
Melting of Spool or Coil	1.8
Mechanical Forces	1.7
Relay Failed to Open	1.7
Relay Socket Failure	0.9
Abnormal Environmental Factor	0.5
Failed to Energize	0.3
Frequency of Testing	0.3
Cause Unknown	<u>19.2</u>
Total Percent	100
Total number of events	882

Relays are used in the RPS and other safety related systems for logic actuation. The number and type of relays used varies depending on plant design. A few of the more noted relay problems will be discussed and the effect on RPS operation assessed. Problems with undervoltage trip relays were discussed in Appendix B as part of the scram breakers.

USNRC Information Notice 82-02<sup>C-4</sup> identified a problem with Westinghouse Type NBFD relays used in some RPS systems. The relays were used in parallel and in the energized state. The failures were in a safe direction, that is if the second relay also failed it would trip the reactor. Replacement coils were recommended for those relays. However, IE Information Notice 82-54 alerted utilities that a higher than expected failure rate was experienced with the replacement coils. The problem was attributed to coil filler epoxy which flowed during service into the plunger cavity which inhibited the relay from de-energizing when power was removed. This type of failure would be in the unsafe direction. This problem was resolved by replacing suspect coils, enhanced inspection, and testing of this type of relay.

IE Bulletin 84-02<sup>C-5</sup> provided information on the failure of the General Electric type HFA relays used in IE safety systems. These relay failures all involved relays that were continuously energized in ac circuits and failed to open when de-energized. The cause of relay failure was the deterioration of the coil wire insulation as a result of the effects of aging. The failure mechanism began with wire insu-

lation failure resulting in shorted turns causing increased coil temperature and eventual coil failure. The exposed coil would melt and deposit materials on the armature and contacts which would cause relay failure. Common mode failures could result in failure of the reactor trip function. The resolution of this particular problem was to replace the HFA relays with the GE Century series HFA relays which use a high temperature wire and a high temperature material *Tefzel* for the spool. Enhanced testing and inspection was also recommended.

Similar end of life failures were reported in IE Notice 84-20<sup>C-6</sup> on the Agastat GP series relays. In this case, failure to operate properly was the result of the nylon movable contact arm coming in contact with the barrier strip on the relay base. This mechanical interference prevented the relay contact from changing state.

After testing by General Electric and Amerace it was determined that these were also end-of-life failures. A design change was made by the manufacturer to correct the problem with the mechanical configuration and tolerance. The qualified series life for the Agastat GP series relays was 4.5 years in the energized state and 10 years in the de-energized state. In this case the 18 month surveillance interval may not be appropriate. More frequent testing of the relays is recommended.

GTE Sylvania relays in service on ESFAS systems had a similar end-of-life coil failure problem. Although in this case the manufacturer had not specified a service life for these normally energized relays.

## CONCLUSIONS

Relays are subject to the effects of aging. For the relays used in the RPS the predominant degradation has been with coils, contacts, and binding. The frequency of burnout of coils is higher for continuously energized coils than for the de-energized ones by about a factor of 2. Other thermally induced problems have occurred, such as the shrinkage of plastic frames for relays. The effects of relay failures on the RPS depends upon whether or not the failure is in a safe direction (cause a trip) or in the

unsafe direction (prevent a trip). Common mode failures in the unsafe direction would be the worst case. However, once a failure has occurred, a failure analysis should be performed to determine the cause, so appropriate preventive measures can be taken. Only 0.7% of component failures in RPS systems have resulted in loss of total system function according to NPRDS data. The low system failure rate is due to redundancy built in the RPS systems.

## REFERENCES

- C-1. Nuclear Power Experience Data Base, the S. M. Stoller Corporation, Boulder, Colorado.
- C-2. G. J. Toman, V. P. Bacanskas, T. A. Shook, and C. C. Ladlow, *The Interactive Effects of Relay and Circuit Breaker Aging in a Safety-Related System*, NUREG/CR-4715, July 1986.
- C-3. S. R. Brown, *Data Summaries of Licensee Event Reports of Protective Relays and Circuit Breakers at U.S. Commercial Power Plants, January 1, 1976 to December 31, 1983* (Draft), NUREG/CR-4126, EG&G Idaho.
- C-4. *W Nbfd Relay Failures in Reactor Protection Systems*, IE Information Notice 82-54.
- C-5. *Failures of General Electric Type HFA Relays in Use in Class IE Safety Systems*, IE Bulletin 84-02.
- C-6. *Service Life of Relays in Safety-Related Systems*, Information Notice No. 84-20.

NRC FORM 336 (2-84) NRCM 1107, J201, J202 <b>BIBLIOGRAPHIC DATA SHEET</b> SEE INSTRUCTIONS ON THE REVERSE	U.S. NUCLEAR REGULATORY COMMISSION 1 REPORT NUMBER (Assign by TDC add Vol No. if any) <b>NUREG/CF-4740</b> <b>EGG-2467</b>
7 TITLE AND SUBTITLE <b>Nuclear Plant-Aging Research on Reactor Protection Systems</b>	J LEAVE BLANK 4 DATE REPORT COMPLETED MONTH YEAR <b>December 1987</b>
5 AUTHOR(S) <b>Leroy C. Meyer</b>	6 DATE REPORT ISSUED MONTH YEAR <b>December 1987</b>
7 PERFORMING ORGANIZATION NAME AND MAILING ADDRESS (Include Zip Code) <b>Idaho National Engineering Laboratory          EG&amp;G Idaho, Inc.          Idaho Falls, ID 83415</b>	8 PROJECT/TASK/WORK UNIT NUMBER 9 FUND OR GRANT NUMBER <b>A6389</b>
10 SPONSORING ORGANIZATION NAME AND MAILING ADDRESS (Include Zip Code) <b>Division of Engineering          Office of Nuclear Regulatory Research          U.S. Nuclear Regulatory Commission          Washington, D.C. 20555</b>	11a TYPE OF REPORT <b>Technical</b> b PERIOD COVERED (Inclusive Dates)
12 SUPPLEMENTARY NOTES	
13 ABSTRACT (200 words or less) <p style="text-align: center;">           This report presents the results of a review of the Reactor Trip System (RTS) and the Engineered Safety Feature Actuating System (ESFAS) operating experiences reported in Licensee Event Reports (LER)s, the Nuclear Power Experience data base, Nuclear Plant Reliability Data System, and plant maintenance records. Our purpose is to evaluate the potential significance of aging, including cycling, trips, and testing as contributors to degradation of the RTS and ESFAS. Tables are presented that show the percentage of events for RTS and ESFAS classified by cause, components, and subcomponents for each of the Nuclear Steam Supply System vendors. A representative Babcock and Wilcox plant was selected for detailed study. The U.S. Nuclear Regulatory Commission's Nuclear Plant Aging Research guidelines were followed in performing the detailed study that identified materials susceptible to aging, stressors, environmental factors, and failure modes for the RTS and ESFAS as generic instrumentation and control systems. Functional indicators of degradation are listed, testing requirements evaluated, and regulatory issues discussed.         </p>	
14 DOCUMENT ANALYSIS - KEYWORDS/DESCRIPTORS b IDENTIFIERS/OPEN ENDED TERMS	15 AVAILABILITY STATEMENT <b>Unclassified</b> 16 SECURITY CLASSIFICATION <i>(This page)</i> <b>Unlimited</b> <i>(This report)</i> <b>Unlimited</b> 17 NUMBER OF PAGES 18 PRICE