



SOLERAS

**Solar Cooling Engineering Field Tests Project**

---

**FINAL REPORT**

**United Technologies Research Center**

---

**Volume 3**

**Engineering Field Test**

**DO NOT MICROFILM  
COVER**

## **DISCLAIMER**

**This report was prepared as an account of work sponsored by an agency of the United States Government. Neither the United States Government nor any agency thereof, nor any of their employees, makes any warranty, express or implied, or assumes any legal liability or responsibility for the accuracy, completeness, or usefulness of any information, apparatus, product, or process disclosed, or represents that its use would not infringe privately owned rights. Reference herein to any specific commercial product, process, or service by trade name, trademark, manufacturer, or otherwise does not necessarily constitute or imply its endorsement, recommendation, or favoring by the United States Government or any agency thereof. The views and opinions of authors expressed herein do not necessarily state or reflect those of the United States Government or any agency thereof.**

---

## **DISCLAIMER**

**Portions of this document may be illegible in electronic image products. Images are produced from the best available original document.**

## Solar Cooling Engineering Field Tests Project

---

# FINAL REPORT

## United Technologies Research Center

---

### Volume 3

### Engineering Field Test

Published for the  
United States – Saudi Arabian Joint Program  
for Cooperation in the Field of Solar Energy  
SOLERAS

by the Program Operating Agent  
Midwest Research Institute  
425 Volker Boulevard  
Kansas City, Missouri 64110 USA

#### DISCLAIMER

This report was prepared as an account of work sponsored by an agency of the United States Government. Neither the United States Government nor any agency thereof, nor any of their employees, makes any warranty, express or implied, or assumes any legal liability or responsibility for the accuracy, completeness, or usefulness of any information, apparatus, product, or process disclosed, or represents that its use would not infringe privately owned rights. Reference herein to any specific commercial product, process, or service by trade name, trademark, manufacturer, or otherwise does not necessarily constitute or imply its endorsement, recommendation, or favoring by the United States Government or any agency thereof. The views and opinions of authors expressed herein do not necessarily state or reflect those of the United States Government or any agency thereof.

**MASTER**

DISTRIBUTION OF THIS DOCUMENT IS UNLIMITED

Available from the National Technical Information Service, U.S. Department of Commerce, Springfield, Virginia 22161.

Price: Printed Copy A09

Microfiche A01

Codes are used for pricing all publications. The code is determined by the number of pages in the publication. Information pertaining to the pricing codes can be found in the current issues of the following publications, which are generally available in most libraries: *Energy Research Abstracts (ERA)*; *Government Reports Announcements and Index (GRA and I)*; *Scientific and Technical Abstract Reports (STAR)*; and publication NTIS-PR-360 available from NTIS at the above address.

#### NOTICE

This report was prepared as an account of work sponsored by the United States Department of Energy and by the Saudi Arabian National Center for Science and Technology. Neither the Kingdom of Saudi Arabia nor the United States nor any agency thereof, nor any of their employees, makes any warranty, expressed or implied, or assumes any legal liability or responsibility for any third party's use or the results of such use of any information, apparatus, product, or process disclosed in this report, or represents that its use by such third party would not infringe privately-owned rights.

# FOREWORD

## THE SOLERAS PROGRAM: A UNIQUE EFFORT IN COOPERATIVE SOLAR ENERGY RESEARCH

In October 1977, Saudi Arabia and the United States signed a Program Agreement for Cooperation in the Field of Solar Energy. The Program, named SOLERAS, is the first of its kind in purpose, funding, organization, and results. It is based on the respective commitments of the United States and Saudi Arabia to advance the development of solar energy as a viable cost-competitive energy alternative, by combining the technical and other unique resources of each country. SOLERAS has made significant progress in demonstrating the effectiveness of solar energy—progress that would have been difficult for either country to achieve on its own.

SOLERAS is sponsored by the government agencies responsible for energy research and development in each country: the Saudi Arabian National Center for Science and Technology (SANCST) and the United States Department of Energy. The Program is under the auspices of the United States-Saudi Arabian Joint Commission on Economic Cooperation, formed in 1974 by the Saudi Arabian Ministry of Finance and National Economy and the United States Department of the Treasury.

Although SOLERAS is only one of more than 30 such projects under the direction of the Joint Commission, it is the only one that is funded by both countries. All other projects are funded completely by Saudi Arabia. This jointly funded program is evidence, therefore, that both countries recognize the mutually beneficial results expected to be generated by the cooperative research projects undertaken by SOLERAS.

The administration of SOLERAS also reflects the philosophy of cooperation underlying this unique Program. Senior officials from SANCST, the Ministry of Finance and National Economy, the U.S. Department of Energy, and the U.S. Department of the Treasury comprise an eight-member Executive Board which governs all aspects of the SOLERAS Program. The Board establishes the goals, objectives, and policies of SOLERAS and oversees the technical and financial management of the projects undertaken to implement those goals and objectives.

A four-member Project Selection Committee, with two members from each government, assists the Executive Board in selecting and evaluating projects. Its members combine their technical expertise and experience in renewable energy technologies and demonstration projects to review proposals, designs, plans, reports, operations, and data for the various projects.

The daily technical and administrative management of the SOLERAS projects is the responsibility of Midwest Research Institute, an independent, not-for-profit research organization, which has been designated as the SOLERAS Operating Agent. MRI utilizes technical and managerial personnel from both countries in fulfilling its responsibility for implementing the decisions of the Executive Board and in managing the individual technical projects. This includes contracting with various companies and research organizations in both countries to design and install state-of-the-art solar systems. SOLERAS program offices are located at MRI's Kansas City, Missouri, headquarters, and in Riyadh and Yanbu, Saudi Arabia.

SOLERAS has initiated several major research projects: converting solar energy into electricity for everyday use by the inhabitants of several rural villages; testing solar energy as a source for space cooling and water treatment; developing agricultural systems using solar energy to control the entire growing environment; undertaking fundamental photovoltaic and solar thermal research; establishing high technology laboratories for advanced solar research at Saudi Arabian universities; and sponsoring basic solar energy research in universities in the United States.

In addition, SOLERAS has contributed to the dissemination of scientific and technical solar information through its sponsorship of technology workshops, short courses, and the publication of technical reports. These have provided an important means of informing the scientific research community about the solar energy technologies developed under SOLERAS and other relevant projects throughout the world.

## تقديم

### «البرنامج السعودي الأمريكي المشترك» للتعاون في ميدان أبحاث الطاقة الشمسية

وقعت المملكة العربية السعودية والولايات المتحدة الأمريكية في عام ١٩٧٧م اتفاقية برنامج التعاون في ميدان أبحاث الطاقة الشمسية . وكان هذا البرنامج الذي سُمي «سوليراس» الأول من نوعه من حيث الغرض والتمويل والتنظيم والنتائج . وهو معتمد على الالتزام المتبادل بين الولايات المتحدة الأمريكية والمملكة العربية السعودية بالعمل على تنمية الطاقة الشمسية ، بوصفها طاقة بديلة متجددة وذات كلفة منافسة ، عن طريق الجمع للموارد الفنية وغيرها من المصادر الطبيعية لكل من البلدين . ولقد حقق برنامج «سوليراس» تقدماً ملحوظاً ببيان فعالية الطاقة الشمسية ، وهو تقدّم قد يكون من الصعب تحقيقه على أي من البلدين منفرداً . يتم انجاز برنامج «سوليراس» تحت رعاية الهيئات الحكومية المسؤولة عن أبحاث وتنمية الطاقة في كل من البلدين ، أي المركز الوطني السعودي للعلوم والتكنولوجيا ووزارة الطاقة الأمريكية . وتشرف على البرنامج اللجنة الأمريكية السعودية المشتركة للتعاون الاقتصادي المكوّنة عام ١٩٧٤م من قبل وزارة المالية والاقتصاد الوطني في المملكة العربية السعودية ووزارة المالية في الولايات المتحدة الأمريكية .

بالرغم من أن برنامج «سوليراس» هو واحد من بين ما يزيد عن ٣٠ مشروعاً تديرها اللجنة المشتركة فإنه البرنامج الوحيد الذي يموله البلدان ، في حين أن جميع البرامج الأخرى تمولها المملكة العربية السعودية كلياً . فيبرهن هذا البرنامج ، المشترك التمويل ، على أن كلا البلدين يعترفان بالفوائد المتبادلة المتوقع تحقيقها من خلال مشاريع البحث التعاوني التي يتداولها برنامج «سوليراس» . وتعكس إدارة «سوليراس» أيضاً فلسفة التعاون التي يستند عليها هذا البرنامج . فيشكّل مسؤولون من المركز الوطني السعودي للعلوم والتكنولوجيا ومن وزارة المالية والاقتصاد الوطني ومن وزارة الطاقة الأمريكية ووزارة المالية الأمريكية مجلساً تنفيذياً يضم ثمانية أعضاء ويدير جميع جوانب برنامج «سوليراس» . فيحدّد هذا المجلس أهداف وغايات وسياسة «سوليراس» كما يشرف على الإدارة الفنية والمالية للمشاريع المباشرة لتحقيق هذه الأهداف والغايات .

تقوم لجنة اختيار المشاريع المكوّنة من أربعة أعضاء ، اثنان من كل جانب بمساعدة المجلس التنفيذي في اختيار وتقييم المشاريع . فيجمع أعضاء هذه اللجنة خبرتهم الفنية وتجربتهم في مجال تكنولوجيا الطاقة المتجددة والمشاريع النموذجية لمراجعة المقترحات والتصاميم والمخططات والتقارير والعمليات والبيانات المتعلقة بالمشاريع المتنوعة .

أما الإدارة الفنيّة والإدارية اليوميّة لمشاريع «سوليراس» فهي تحت مسؤوليّة «مدوست ريسيرتش انستيتيوت» (معهد «مدوست» للأبحاث) . وهو معهد أبحاث مستقل ليس ذا صبغة تجارية ، تم تعيينه كوكيل تشغيل لبرنامج «سوليراس» . ويستخدم معهد «مدوست للأبحاث» فنيين وإداريين من كلا البلدين للقيام بمسؤولية تنفيذ قرارات المجلس التنفيذي وإدارة المشاريع الفنية الفردية . ويشمل ذلك التعاقد مع مختلف الشركات ومعاهد الأبحاث في كلا البلدين لتصميم وتركيب أنظمة طاقة شمسية من أحدث تكنولوجيا . وتقع مكاتب برنامج «سوليراس» في المقرّ الرئيسي لمعهد «مدوست للأبحاث» بمدينة كنساس سيتي بولاية ميسوري وكذلك في الرياض وينبع بالمملكة العربية السعودية .

انبعث من برنامج «سوليراس» العديد من مشاريع الأبحاث الكبرى ، منها تحويل الطاقة الشمسية الى كهرباء للاستعمال اليومي لسكّان العديد من القرى الريفية واختبار الطاقة الشمسية كمصدر طاقة للتبريد والتدفئة وتحمية المياه وتطوير أنظمة زراعية باستعمال الطاقة الشمسية للتحكم في كامل بيئة الانماء ، والقيام بأبحاث نظرية حول الخلايا الكهروضوئية والحرارة الشمسية وانشاء مختبرات تكنولوجيا عالية للأبحاث الشمسية المتقدمة في الجامعات السعودية ورعاية أبحاث أساسية في الطاقة الشمسية في جامعات بالولايات المتحدة الأمريكية .

كما أن برنامج «سوليراس» ساهم في نشر المعلومات العلمية والفنية المتعلقة بالطاقة الشمسية من خلال رعايته للندوات العلمية والدورات القصيرة ونشر التقارير الفنية . ولقد كان ذلك وسيلة لنقل معلومات هامة لمجموعة الباحثين العلميين حول تكنولوجيا الطاقة الشمسية المطوّرة من خلال برنامج «سوليراس» والمشاريع الأخرى المرتبطة به عبر بلدان العالم .

Engineering Field Test of A  
Solar Cooling System

TABLE OF CONTENTS

|                                                                      | <u>Page</u> |
|----------------------------------------------------------------------|-------------|
| PREFACE . . . . .                                                    | 3           |
| EXECUTIVE SUMMARY . . . . .                                          | 6           |
| INTRODUCTION . . . . .                                               | 32          |
| 1.0 SITE LOCATION AND BUILDING SELECTION . . . . .                   | 1-1         |
| 1.1 Site Location Selection . . . . .                                | 1-1         |
| 1.2 Building Selection . . . . .                                     | 1-1         |
| 1.3 Description of Building . . . . .                                | 1-5         |
| 1.4 Air Conditioning Needs . . . . .                                 | 1-5         |
| 2.0 SYSTEM DESCRIPTION . . . . .                                     | 2-1         |
| 2.1 Solar Collector/Storage Subsystem . . . . .                      | 2-1         |
| 2.2 Chiller Module . . . . .                                         | 2-1         |
| 2.3 Thermal Distribution Subsystem . . . . .                         | 2-4         |
| 3.0 DESIGN ANALYSIS . . . . .                                        | 3-1         |
| 3.1 Chiller Module Design and Selection . . . . .                    | 3-1         |
| 3.2 Solar Collector/Storage Subsystem Design and Selection . . . . . | 3-14        |
| 3.3 Thermal Distribution Subsystem Design and Selection . . . . .    | 3-18        |
| 3.4 Central Control System Design . . . . .                          | 3-22        |
| 3.5 Data Acquisition System . . . . .                                | 3-25        |
| 3.6 Performance Analyses . . . . .                                   | 3-30        |
| Phase II                                                             |             |
| 4.0 DETAILED DESIGN, CONSTRUCTION AND INSTALLATION . . . . .         | 4-1         |
| 4.1 System Installation Design and Construction . . . . .            | 4-1         |
| 4.2 Reliability and Maintainability Analysis . . . . .               | 4-29        |

## TABLE OF CONTENTS (Cont'd)

|                                                                 | <u>Page</u> |
|-----------------------------------------------------------------|-------------|
| 5.0 TESTING DOCUMENTATION . . . . .                             | 5-1         |
| 5.1 Checkout Tests . . . . .                                    | 5-1         |
| 5.2 Acceptance Tests . . . . .                                  | 5-1         |
| Phase III                                                       |             |
| 6.0 PROTOTYPE SYSTEM TESTING . . . . .                          | 6-1         |
| 6.1 Operational Data Summary . . . . .                          | 6-6         |
| 6.2 System Performance Summary . . . . .                        | 6-11        |
| 6.3 Reliability and Maintainability Summary . . . . .           | 6-23        |
| 6.4 Summary and Recommendations . . . . .                       | 6-27        |
| REFERENCES                                                      | R-1         |
| APPENDIX A - DATALOGGER DATA PROCESSING RELATIONSHIPS . . . . . | A-1         |

## PREFACE

This report constitutes the final documentation of a three phase program conducted under Cooperative Agreement No. DE-FC02-80ET-2064 on behalf of the U.S. Department of Energy and Saudi Arabian National Center for Science and Technology. The Midwest Research Institute (MRI) acted as operating agent. The work was performed by the United Technologies Research Center (UTRC) in conjunction with the Hamilton Standard Division of United Technologies (UTC) and its subsidiary Hamilton Test Systems, Inc. and with support from several subcontractors. Mr. F. R. Biancardi was UTRC Program Director and Mr. G. Melikian was Program Manager. Mr. G. Melikian also acted as Task Manager for Phase I activities. Mr. M. D. Krosney was the Task Manager for Phase II activities and Mr. C. E. Kepler was Task Manager for Phase III. Mr. J. Williamson was the MRI Program Director and Mr. R. L. Martin was Program Manager.

Team members and their areas of responsibility are indicated in Fig. 1 and key personnel contributing to this program are listed in Table 1.

### PROGRAM RESPONSIBILITIES

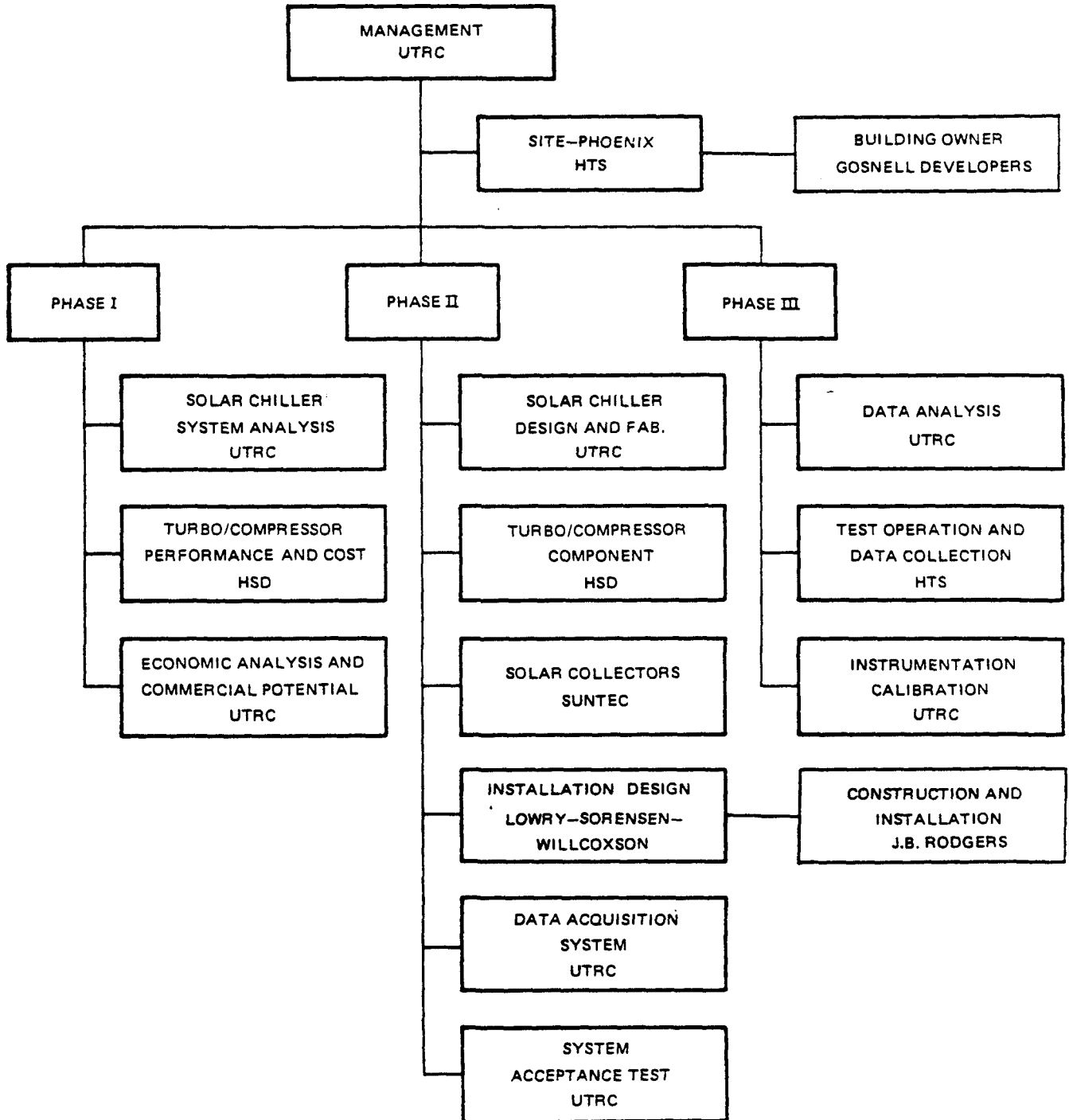

TABLE 1

KEY CONTRIBUTING PERSONNEL

| <u>UTRC</u>      | <u>HSD</u>                | <u>Lowry, Sorensen &amp; Willcoxson</u> |
|------------------|---------------------------|-----------------------------------------|
| T. J. Anderson   | J. Berger                 | T. G. Johns                             |
| A. J. Bednarczyk | J. W. Sitler              |                                         |
| F. R. Biancardi  |                           |                                         |
| W. A. Blecher    | <u>HTS</u>                | <u>J. B. Rodgers</u>                    |
| A. I. Chalfant   | J. Hesse                  | R. Rodgers                              |
| C. E. Kepler     | M. Hernandez              |                                         |
| H. E. Khalifa    | D. Perry                  | <u>Suntec Corp.</u>                     |
| M. D. Krosney    |                           | J. Davidson                             |
| M. D. Meader     |                           | D. Cates                                |
| P. C. November   |                           |                                         |
| T. N. Obee       | <u>Gosnell Developers</u> |                                         |
| H. M. Packard    | D. Gosnell                |                                         |
| G. T. Peters     | C. W. Bisch               |                                         |
| B. W. Rhodes     |                           |                                         |
| D. D. Santos     |                           |                                         |
| J. A. Thoren     |                           |                                         |
| G. Melikian      |                           |                                         |
| A. M. Landerman  |                           |                                         |

## EXECUTIVE SUMMARY

## ABSTRACT

A solar-powered air conditioning system was designed, constructed, and installed at a Phoenix, Arizona site whose climatic conditions approximate those of Saudi Arabia. The nominal 18 ton capacity Rankine cycle chiller system with hot and cold storage and conventional fan/coil delivery units was operated for two cooling seasons and met its design objectives.

## INTRODUCTION

Saudi Arabia and the United States signed an agreement in October 1977 for cooperation in the field of solar energy (SOLERAS) under the auspices of the United States-Saudi Arabian Joint Commission on Economic Cooperation. The objectives of the agreement are: (1) to cooperate in the field of solar energy technology for the mutual benefit of the two countries, including the development and stimulation of solar industries within the two countries; (2) to advance the development of solar energy technology in the two countries, and (3) to facilitate the transfer between the two countries of technology developed under this agreement.

A specific objective of the SOLERAS program is to promote the development of active solar cooling systems for urban areas in hot environments. To further this objective, the Solar Energy Research Institute (SERI) awarded several contracts to further the development of active solar cooling systems for commercial applications with special emphasis on improving the performance figures of merit beyond the levels achievable by existing solar cooling systems. One of these contracts was awarded to the United Technologies Research Center (UTRC) with support from Hamilton Standard Division (HSD) of United Technologies Corporation (UTC).

UTC's approach to this program was to design, analyze and construct a Rankine-cycle solar cooling system and conduct an engineering field test of the system in a climate that simulates that of Saudi Arabia. For this application UTRC modified an existing prototype heat pump module designed, fabricated and tested under DOE funding (Solar Turbocompressor Heat Pump - STHP Contract No. AC 03-79-CS34510) for cooling use only (Ref. 1). This dual-loop Rankine-cycle power and Rankine-cycle cooling prototype unit utilizes a single working fluid (R11) and a high performance turbocompressor developed specifically for this application by the Hamilton Standard Division of UTC. The prototype heat pump had been operated in the laboratory with water-cooled condenser at condenser conditions simulating indirect air-cooling with a 95 F ambient

air temperature and approached its predicted design output capacity of 18 tons with a thermal COP of 0.6. To achieve comparably good performance at higher ambient air temperatures encountered in the SOLERAS program, this (chiller) module was modified for direct air cooling by utilizing air-cooled refrigerant condensers.

The chiller module is one of three major subsystems that comprise the overall cooling system installation. A solar collector/storage subsystem collects energy from available sunlight and heats water stored in the hot tank. The stored hot water provides thermal energy for either immediate or future use to drive the turbine in the chiller Rankine-cycle power loop. Since the chiller module was designed to operate efficiently at water temperature of 200 to 300 F an array of medium concentrating type collectors was employed. A thermal distribution subsystem was used to store and transport cold water generated in the chiller module to air handler/fan coil units to provide the building air conditioning.

The site selected for the engineering field testing of the solar powered cooling system is the Hamilton Test Systems (HTS) central office building located in Phoenix, Arizona.

A summary of contract activities under the three-phase field test program and results achieved is provided in the following sections.

## PHASE I - SOLAR COOLING SYSTEM DESIGN AND ANALYSIS

### Site and Building Selection

Saudi Arabian summer climate is characterized by high dry-bulb temperature and negligible precipitation. The three largest cities in Saudi Arabia have 2-1/2 percent summer design conditions as indicated in Table S-1. The two coastal cities, Jeddah (on the Red Sea) and Dhahran (on the Persian Gulf) are both hot and humid, whereas Riyadh, the capital, is hot and dry. An examination of the summer design conditions for U.S. cities in the ASHRAE Handbook of Fundamental (1977) revealed that although a large number of locations in the southwestern United States have dry-bulb temperatures that equal or exceed those of the three major Saudi Arabian cities, none combines the high temperature and high humidity characteristics of Jeddah, and particularly, Dhahran. The cooling load characteristics of commercial office buildings in any hot climate will be fairly representative of those for similar office buildings in all three Saudi Arabian cities since outdoor air humidity affects only ventilation and infiltration loads which are a small fraction of the total cooling load. Summer design conditions in El Centro, Blythe, Needles and Palm Springs in the state of California, as well as Phoenix and Yuma in the state of Arizona are fairly close to the condition in Riyadh. The city of Phoenix is of particular interest because its average summer conditions (dry bulb and daily range) are very close to those of Riyadh as indicated in Table S-1.

TABLE S-1

## SUMMER DESIGN CONDITIONS

THREE MAJOR CITIES IN SAUDI ARABIA\*

| City                             | Latitude/<br>Longitude | Elevation,<br>ft | Design DBT,<br>F |        | Daily Range,<br>F | Design WBT,<br>F |        |
|----------------------------------|------------------------|------------------|------------------|--------|-------------------|------------------|--------|
|                                  |                        |                  | 1%               | 2-1/2% |                   | 1%               | 2-1/2% |
| Dhahran                          | 26°17'N/<br>50°09'E    | 80               | 111              | 110    | 32                | 86               | 85     |
| Jeddah                           | 21°28'N/<br>39°10'E    | 20               | 106              | 103    | 22                | 85               | 84     |
| Riyadh                           | 24°39'N/<br>46°42'E    | 1938             | 110              | 108    | 32                | 78               | 77     |
| <u>CITY OF PHOENIX, ARIZONA*</u> |                        |                  |                  |        |                   |                  |        |
| Phoenix                          | 33°3'N/<br>112°0'W     | 1117             | 109              | 107    | 27                | 76               | 75     |

\* Taken from ASHRAE Handbook of Fundamentals, 1977.

An extensive screening of office buildings owned or leased by United Technologies and its subsidiaries was undertaken to identify those buildings that would best serve the purpose of the engineering field test of a solar cooling system. The most suitable of these is the headquarters office building of Hamilton Test Systems (HTS), a subsidiary of the HSD of UTC, in Phoenix, Arizona.

As shown in Fig. S-1, this building is located in a densely populated commercial area of Phoenix next to a Granada Royale Homotel. About 6000 ft<sup>2</sup> of open lawn area was available behind the building (south end). This area receives direct solar radiation from about 7 a.m. to sunset in the summer months (the Granada Royale Homotel, located about 200 ft to the east, shades the back lot from sunrise till about 7 a.m.). This back lot, therefore, constituted the ideal location for the solar collector field.

The 7000 ft<sup>2</sup> single-story office building of energy-efficient design was constructed in 1975. A summary of pertinent building data is provided in Table S-2.

The HTS building is air conditioned by means of six roof-top electric air conditioning units rated at a total of 32.5 tons comprised of five 5-ton units and a 7.5 ton unit. One 5-ton unit is dedicated to the computer room. Two 5-ton units and the 7.5 ton unit are located on the southern end of the building and supply cooling to three zones comprising approximately 60 percent of the building. The combined rated capacity of these three units (17.5 tons) is approximately equal to the rated capacity of the UTC prototype turbocompressor solar cooling system (18 tons). Accordingly, the UTC solar cooling system was designed to provide cooling to the areas served by these electric air conditioners. The existing HVAC ducting system is utilized by both the solar cooling system and the existing electric air conditioners which provide back-up cooling capacity.

### System Description

The solar air conditioning system depicted in schematic form in Fig. S-2 is comprised of three major subsystems. These are the solar collector/storage subsystem, the chiller module subsystem, and the thermal distribution subsystem. The general features and functions of these subsystems are briefly described below.

#### Collector/Storage Subsystem

The solar collector/storage subsystem is comprised of an array of solar collectors, an insulated hot water storage tank, a circulating water pump and appropriate plumbing and valves. Water is circulated in a closed loop through the collectors absorbing energy from the available sunlight. When this water is heated sufficiently it is directed into the storage tank increasing the temperature of the water stored therein. When needed the stored hot water is transported to the chiller module by means of the vaporizer water pump.

# FIELD TEST SITE DEVELOPMENT PLAN

SCALE AS SHOWN

SCALE 1" = 100'

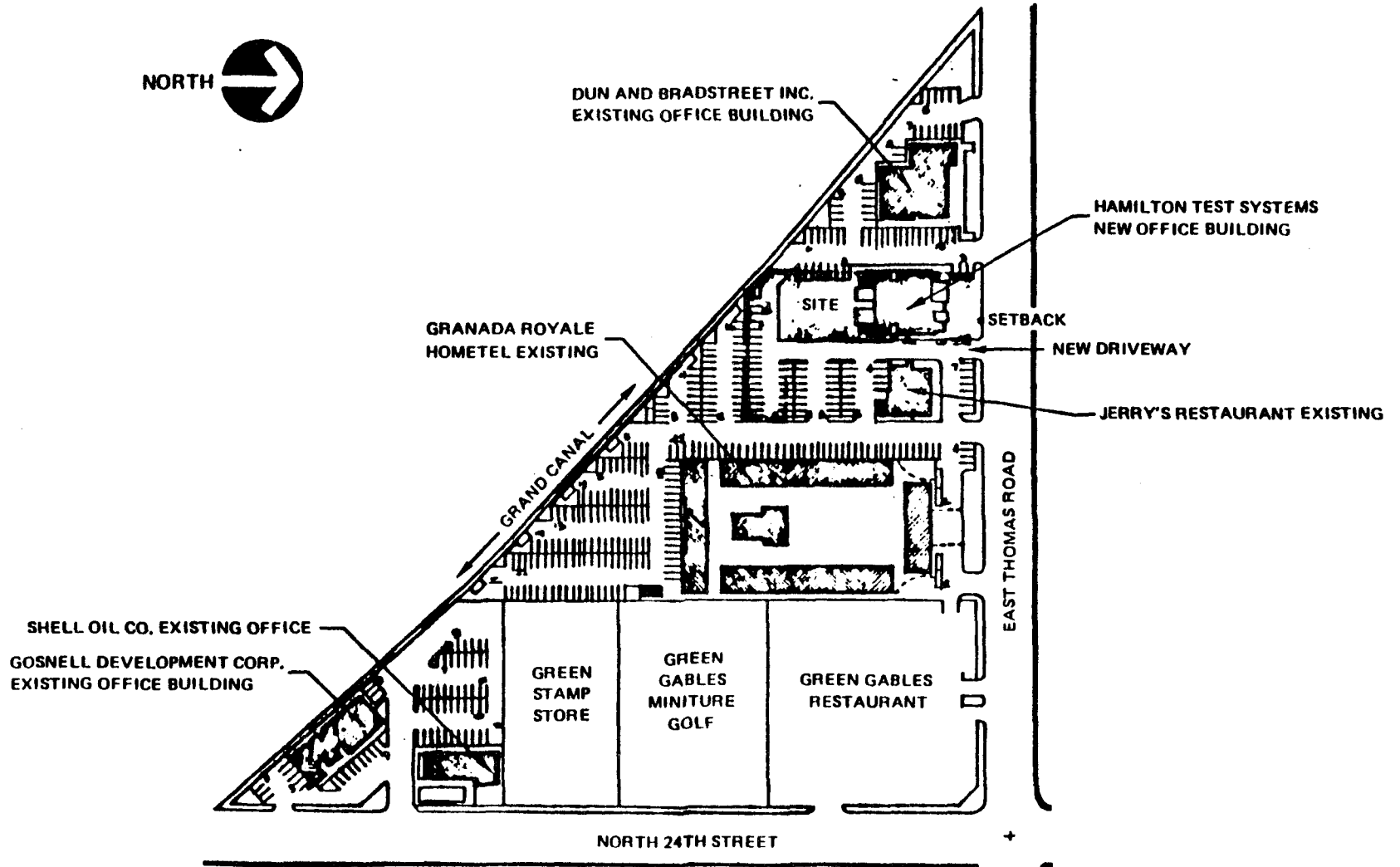

TABLE S-2

SUMMARY OF BUILDING DATA

Location: 2303 East Thomas Rd., Phoenix, Arizona

Function: Office building for Hamilton Test Systems

Owner: Gosnell Development Corporation  
2728 North 24th St., Phoenix, Arizona

Date Built: 1975

Type of Construction: One-story, wood frame with stucco finish

Plan Area: 7000 ft<sup>2</sup> (approximately)

Occupancy: 30 office workers

Air Conditioning System: Six roof-top units totaling 30.5 tons  
(4 x 5 + 1 x 7.5 + 1 x 3 tons) +  
air distribution system

Heating System: Electric resistance heaters installed in ducts

Air Conditioning Units to be Replaced by Solar System: 2 x 5 + 1 x 7.5  
tons (17.5 tons)

Back-up System to be Used with Solar System: Existing electrically driven units

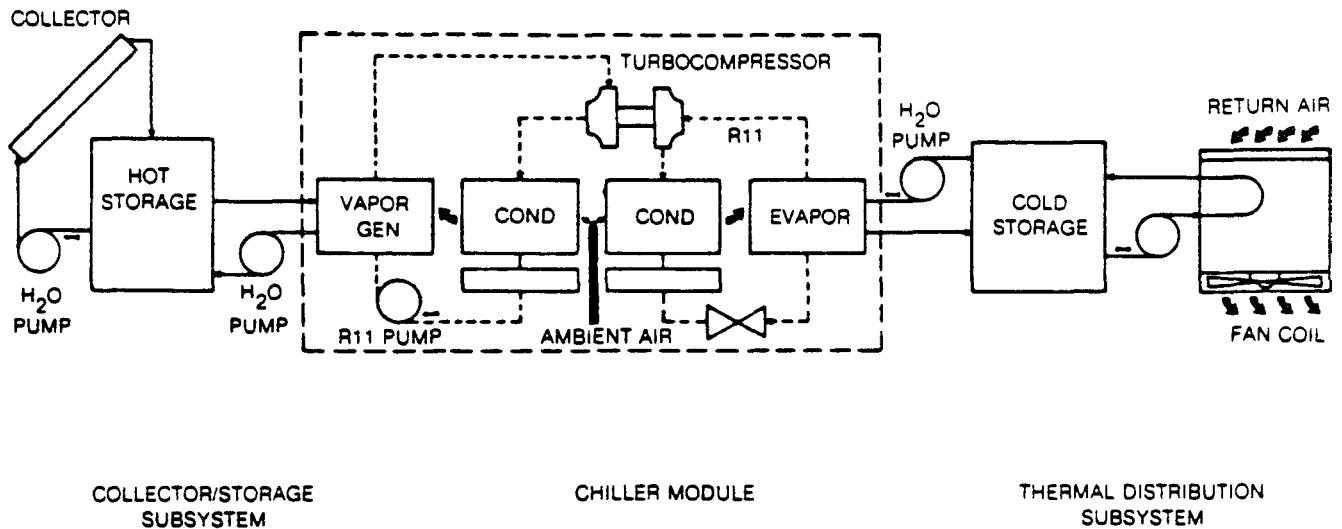

FIGURE S-2. SOLAR COOLING SYSTEM

### Chiller Module

The chiller module consists of a Rankine-cycle engine driving a vapor-compression refrigeration unit. Hot water is supplied to the vapor generator from the storage tank to produce pressurized R11 working fluid vapor. The vapor is expanded through a single-stage radial inflow turbine and is condensed into liquid by rejecting heat via an air cooled condenser. The working fluid liquid is returned to the vapor generator by a motor-driven pump.

The turbine is directly coupled to a single-stage centrifugal compressor in the vapor compression (refrigeration) loop. High-pressure R11 working fluid vapor leaving the compressor is condensed by rejecting heat in a second air cooled condenser. The liquid is then throttled to a low pressure by a float operated expansion valve. The low-pressure liquid is boiled in the evaporator by heat exchange with water which in turn is reduced in temperature. This chilled water is the source of the air conditioning. The working fluid vapor leaving the evaporator is directed to the compressor thus completing cycle.

### Thermal Distribution Subsystem

This subsystem consists of a cold water storage tank, circulating pumps, self-contained air handling fan-coil units and necessary plumbing and valves. When air conditioning is called for by the building thermostats, cold water is transported from the storage tank to the cold water coils in the air handling units. Air is forced over these coils to cool room return air which is distributed through the duct system. These air handling fan-coil units are installed in parallel with the backup electric air conditioners and utilize the existing distribution ducts.

## Design Analysis

System and component performance evaluations and trade-offs conducted to arrive at the system design and operating characteristics utilized established ASHRAE calculation methods and extensive application of UTRC and modified TRNSYS computer programs. General design considerations are based on previous UTC analyses and experimental efforts and standard practices adopted by the solar and HVAC industries. In order to limit risk and cost and to carry out the program in a timely manner, only those changes to the existing Solar Turbocompressor Heat Pump (STHP) module needed to insure efficient and reliable operation were made and the selection of any new equipment was limited to readily available commercial products.

The chiller module utilized much of the existing pallet, structure and heat pump (STHP) components. The major modifications included replacement of the STHP water-cooled condensers with remote air-cooled condensers located outside the building on the roof and appropriate controls necessary for reliable stand-alone operation.

### Hardware Selection

With all elements of the chiller module defined, analyses were made to evaluate the module performance over the full range of module boundary conditions. To accomplish this, the UTRC Rankine Cycle Performance Prediction (RCP) computer program was revised to model the performance characteristics of the modified components. All loss coefficients for pressure drops, heat losses, and mechanical work loss were modified to reflect values measured during tests conducted in the UTRC laboratory facility (Ref. 1).

Predicted cooling output (tons) and Coefficient of Performance (COP) are shown in Fig. S-3 as a function of vaporizer water temperature, ambient temperature, and evaporator inlet water temperature. At the 18-ton design point, a COP of  $\sim 0.6$  is indicated with 287 F vaporizer water temperature, 95 F ambient air temperature, and 55 F evaporator inlet water temperature.

In order to select the most appropriate collector/storage system configuration the effects of collector size and storage tank size on overall system performance were evaluated using the RCP and TRNSYS computer programs. Results of these analyses provided the basis for selecting two rows of Suntec collectors providing 1316 ft<sup>2</sup> area, a 1500-gal hot storage tank and a 2000-gal cold storage tank. By using this combination of collector and tank sizes in conjunction with the UTRC chiller module, the output profile provided by the solar cooling system would match the air conditioning load profile of the HST building being served.

### SOLERAS PREDICTED PERFORMANCE

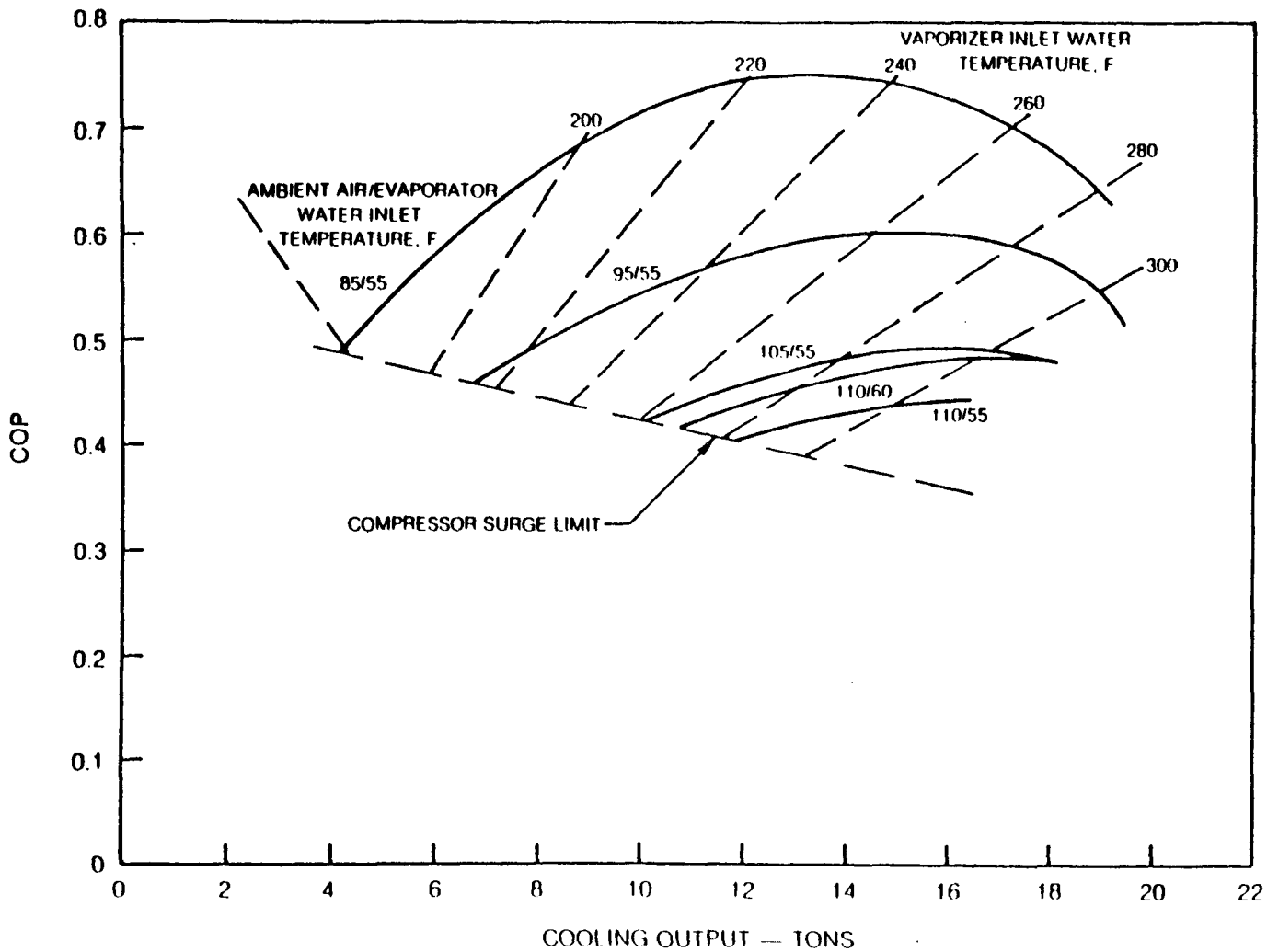

The performance and size data for several air handling fan-coil models made by Carrier, Magic Aire and McQuay were examined and intercompared. A comparison of those units that satisfy the installation size and the performance requirements resulted in a selection of Carrier Models 42BH5 and 42BH6 for the field test.

A control system based on the use of a central controller was utilized to integrate the operations of the major subsystems, components of the solar cooling system and the backup air conditioners into a complete and automatic system. The overall control system concept selected for the application (shown in schematic form in Fig. S-4) is based on simple on/off operation of the major subsystems. The control system was designed to (1) be simple yet provide the flexibility needed to permit maximum solar contribution, (2) provide control which would not impair backup system operation when required, and (3) utilize standard HVAC components.

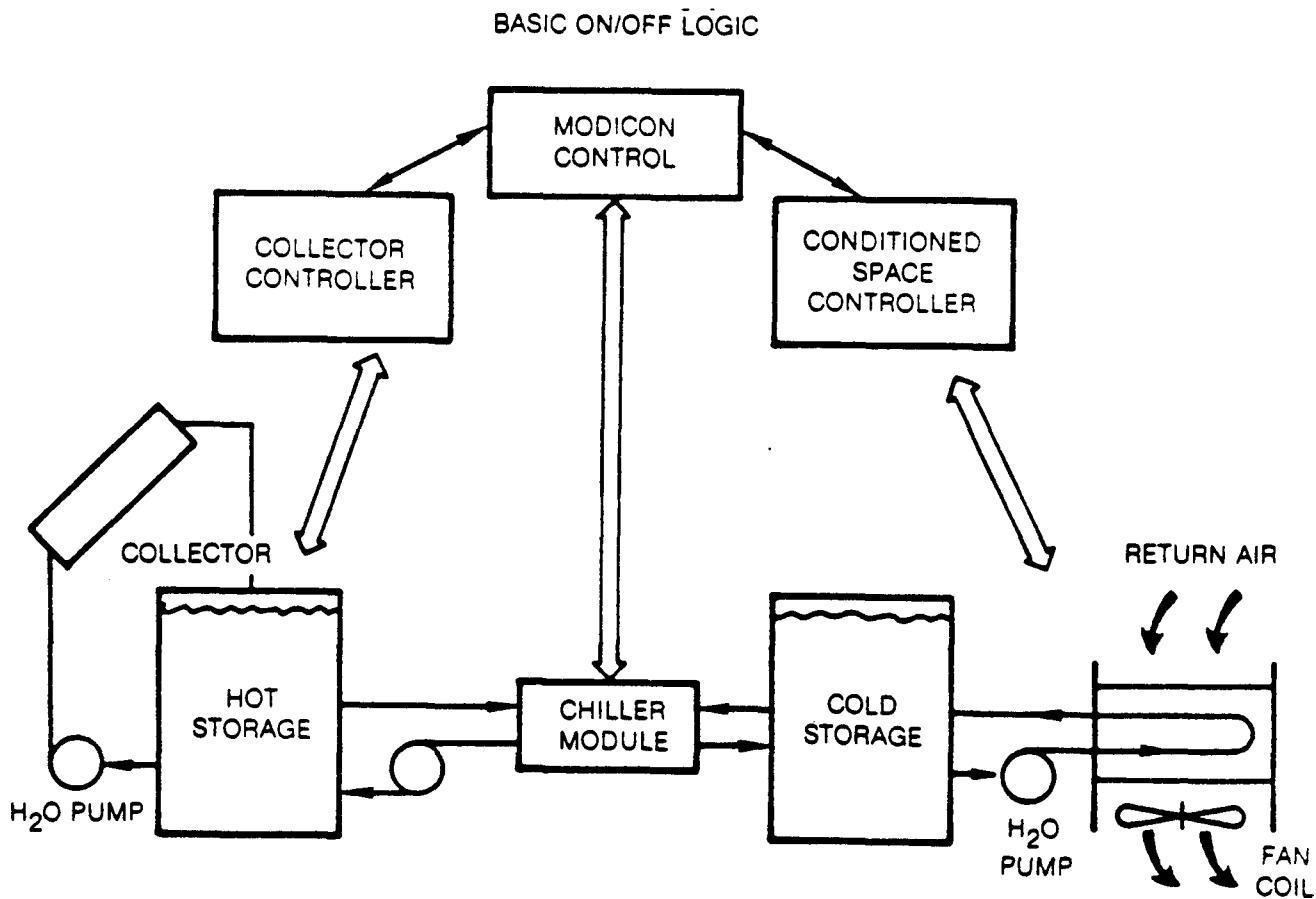

FIGURE S-4. CONTROL SYSTEM CONCEPT

TRNSYS simulations were also used to model alternative system control strategies and set points. A Modicon microprocessor-based minicomputer controller was chosen to perform all required turn ON-OFF sequences as dictated by the control requirements. This unit was selected by UTRC (and funded by UTRC) as a test vehicle to assist in the final characterization of the overall cooling system. The Modicon controller provided the flexibility necessary to accommodate changing requirements which were to be expected during the evaluation phase of the solar cooling system and the control logic for normal and emergency operation of the chiller, including definition of permissive operational sequences and time delays.

### Seasonal Performance

Having selected control system strategies and set points, TRNSYS simulation analyses were conducted to assess the potential seasonal performance of the solar cooling system in the HTS building. The results of these analyses are summarized in Table S-3 including the number of hours each major subsystem is operated for each month and for the entire year. Based on these operating times the cooling system performance data presented, itemizes the cooling (ton-hr) delivered by and electrical consumption (kW-hr) of the solar subsystems and the backup electric units. Also included are the electric energy efficiency ratios (EER's) predicted for the solar subsystem (with and without the fan coil contribution). On an annual basis the solar subsystem would provide as much as 70 percent of the building air conditioning needs. The potential average EER of the solar cooling system is predicted to be 17.8 Btu/hr-W without the f/c contribution. This compares to typical values of 6.5 to 7.5 for the electric air conditioning chillers. Even an advanced electric air conditioner (chiller) would have an EER of only 8.5 to 10.5.

## PHASE II - SOLAR COOLING SYSTEM DETAILED DESIGN, CONSTRUCTION AND INSTALLATION

### System Installation Design and Construction

Detailed design of the solar system installation (plumbing, electrical, mechanicals and layouts) was subcontracted to Lowry-Sorenson-Willcoxson Engineers, Inc., of Phoenix, Arizona. Collector support structure architectural and structural design services were contracted to Gosnell Developers of Phoenix, Arizona. These subcontracted services included preparation of plans, specifications and general conditions for construction/installation of the entire solar cooling system.

TABLE S-3

## SUMMARY OF PREDICTED SYSTEM PERFORMANCE

(a) Monthly Performance

| Month               | Cooling Delivered<br>(ton-hr) |        | Electrical Consumption<br>(kW-hr) |        | Solar System<br>(EER) Btu/hr-W |                | Average<br>Output<br>(tons) |
|---------------------|-------------------------------|--------|-----------------------------------|--------|--------------------------------|----------------|-----------------------------|
|                     | Solar                         | Backup | Solar                             | Backup | with<br>f/c (2)                | without<br>f/c |                             |
| Jan                 | 92                            | 0      | 83                                | 0      | 13.3                           | 15.0           | 13                          |
| Feb                 | 118                           | 0      | 155                               | 0      | 9.1                            | 9.9            | 15                          |
| Mar                 | 627                           | 0      | 475                               | 0      | 15.8                           | 18.3           | 17.7                        |
| Apr                 | 908                           | 0      | 651                               | 0      | 16.7                           | 19.5           | 17.9                        |
| May                 | 1136                          | 454    | 802                               | 816    | 17.0                           | 20.2           | 17.7                        |
| Jun                 | 1468                          | 828    | 1161                              | 1574   | 15.2                           | 18.5           | 15.6                        |
| Jul                 | 1620                          | 1085   | 1272                              | 1844   | 15.3                           | 18.5           | 15.4                        |
| Aug                 | 1493                          | 1005   | 1234                              | 1865   | 14.5                           | 17.5           | 14.5                        |
| Sept                | 1263                          | 755    | 1057                              | 1354   | 14.3                           | 17.2           | 14.2                        |
| Oct                 | 850                           | 339    | 755                               | 586    | 13.2                           | 15.2           | 12.6                        |
| Nov                 | 625                           | 0      | 455                               | 0      | 16.5                           | 19.6           | 18.6                        |
| Dec                 | 222                           | 0      | 225                               | 0      | 11.8                           | 13.2           | 15.4                        |
| Seasonal<br>Totals: | 10,422                        | 4,466  | 8,345                             | 8,039  | 15.0                           | 17.8           |                             |

$$\text{Percent Solar} = \frac{10,422}{10,422 + 4,466} = 70\%$$

(b) Seasonal Operating Time, Hours

| <u>Collector</u> (1) | <u>Fan-Coil</u> | <u>Chiller Module</u> | <u>Backup</u> |
|----------------------|-----------------|-----------------------|---------------|
| 3614                 | 661.6           | 671.1                 | 272.3         |

(1) Maximum possible, actual is approximately 2 to 3 times chiller operating hours

(2) f/c = Air handling fan-coil fan and circulating water pump

A local installation contractor, J. B. Rodgers Mechanical Contractors, was employed to provide and install electric power services, all water piping, instrumentation wiring, various control relays; as well as install the chiller module, indoor fan/coil units, storage buffer and expansion tanks. In addition, the contractor constructed the collector support structure and equipment room and assembled and installed the solar collectors. Construction began the first week of November 1980 and the installation was completed in late February 1981. A photograph of the completed system is presented in Fig. S-5.

As shown, the single-axis tracking parabolic trough solar collectors are mounted atop a carport specially designed and constructed for this project. The chiller module located in an enclosed equipment room at the north end of the carport is shown in Fig. S-6. Air cooled condensers are mounted on the roof between the two rows of collectors (not visible in Fig. S-5). The building to be air conditioned is to the north of the carport.

Hot and cold water storage tanks were insulated and buried in tandem (see Fig. S-7) alongside the carport. Access to the tank connections (on the top of the tank) is by means of a hatch covered well.

Solar air conditioning of the HTS building was achieved by connecting three self contained fan-coil units into the existing duct work. Each fan coil assembly is equipped with its own pump which draws chilled water from the 2000-gal cold storage tank when there is a demand for cooling.

#### Site Instrumentation and Data Acquisition

To control and monitor the operation of the UTC solar air conditioning system, a total of 35 temperature, pressure and frequency sensors were installed. Output signals from the sensors are processed in an Acurex Autodata Ten/5 data acquisition system (DAS) and recorded in engineering units. Selected processed signals from the datalogger are sent to the Modicon controller and utilized to actuate normal startup, run, shutdown and safety control functions.

Data are recorded on magnetic tapes which are periodically sent back to UTRC where they are processed to arrive at the daily averages. The daily averages are used to prepare weekly and monthly performance summaries. Manual recordings are taken of the two electric service power meters to provide a record of the consumption by the solar cooling system and by the electric backup units.

# UTC SOLAR COOLING SYSTEM INSTALLATION

R82-955027-2



19

FIG. S-5

CHILLER PACKAGE/EQUIPMENT ROOM

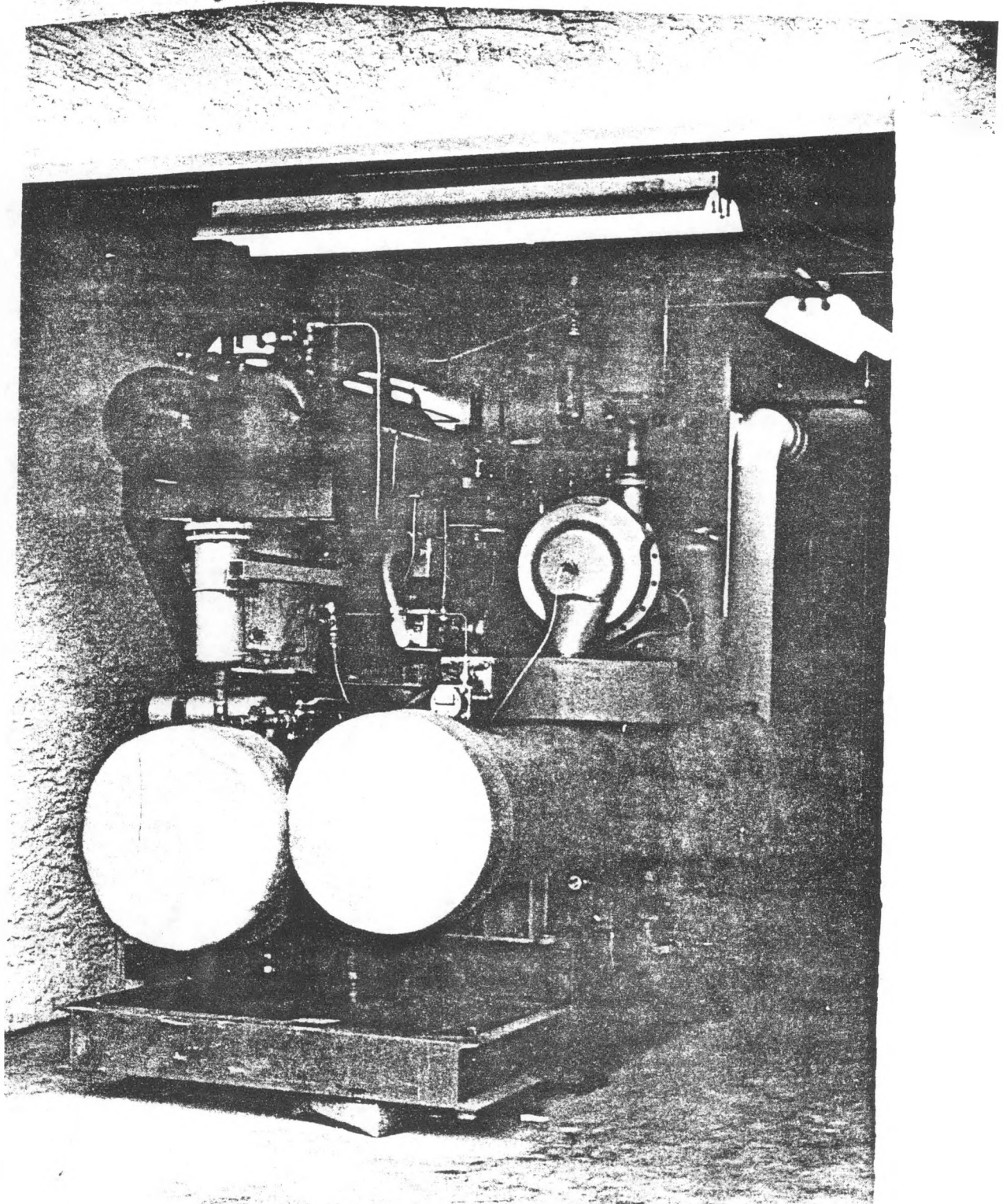

### HOT AND COLD STORAGE TANK INSTALLATION

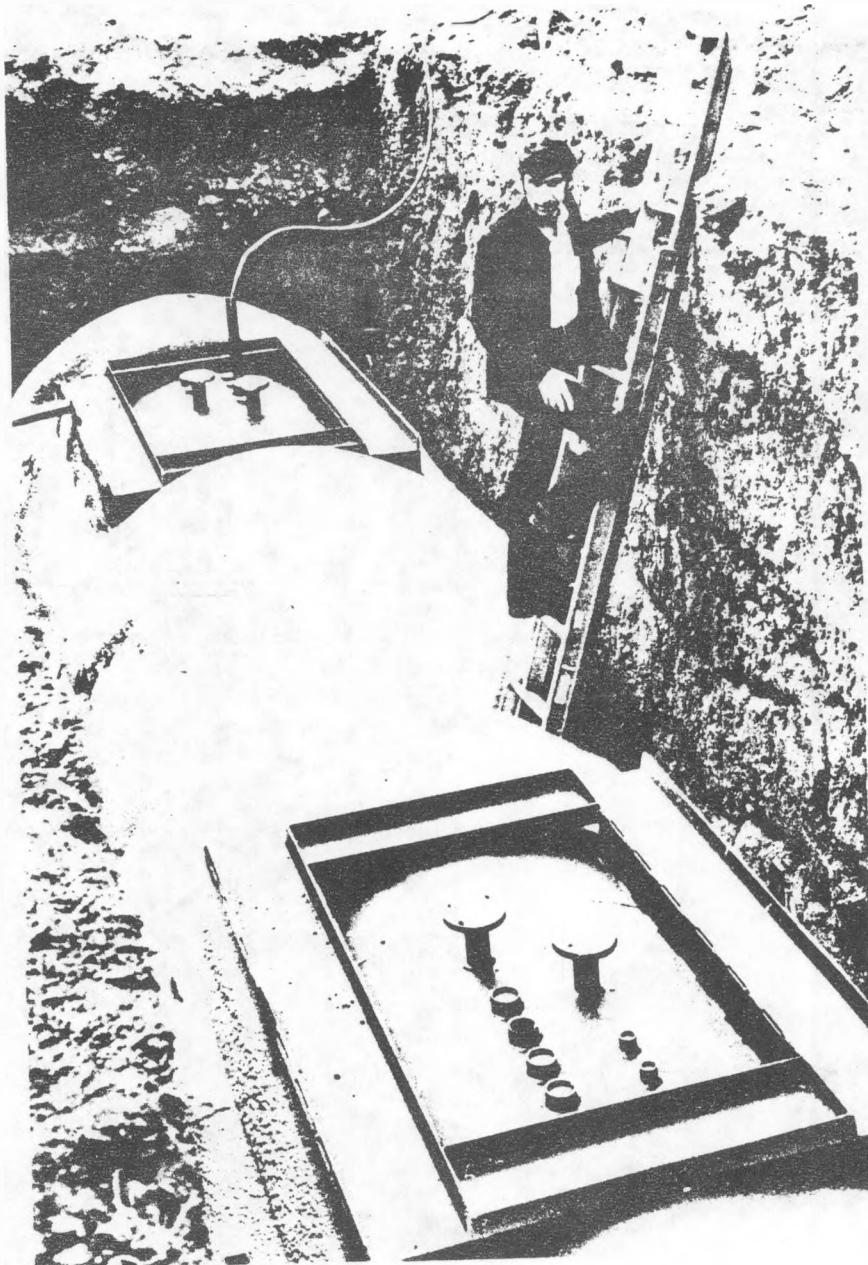

## Testing Documentation

### Checkout Tests

After completion of the solar cooling system installation, various checkout tests were conducted in late February and March of 1981. The checkout tests included operation, adjustment and performance verification of the collector/storage subsystem, chiller module, thermal distribution subsystem, all controls, DAS and data recording hardware. The entire solar cooling system was operated over a wide range of conditions in all manual and automatic operating modes. The performance and operation of each subsystem was generally consistent with analytical predictions. For example, the collector system was operated under the control of the local and master controller and routinely developed temperatures up to and over 300 F, collected and stored heat at efficiencies between 50 and 60 percent.

The chiller was operated at conditions equivalent to ambient temperatures of 90 to 110 F with vaporizer water temperatures of 220 to 307 F. The performance achieved during these checkout tests is compared with predicted values in Fig. S-8. The chiller delivered 8 to 20.5 tons of chiller water at 41 to 50 F and COP's were approximately equal to the values predicted for these conditions (0.4 to 0.7).

Each of the fan-coil units was operated in manual and automatic modes (under control of building thermostats) and each delivered in excess of their rated cooling output.

### Acceptance Tests

Acceptance tests were conducted on April 1, 1981 to demonstrate the operational and performance capabilities of the UTC solar cooling system installation. A series of tests was conducted wherein the collector/storage subsystem, chiller subsystem, and building cooling subsystem were operated in all normal and emergency modes. These tests were entirely successful, i.e., all subsystems and components operated normally. The complete solar system was operated for approximately 5 hours wherein the thermal performance of each subsystem was documented. These collector/storage, chiller, and building cooling subsystems performance were all equal to or better than design predictions. For example, the collector efficiency approached 60 percent, chiller COP averaged 0.55 for 5 hours and ranged from 0.5 to 0.9. Each of the fan-coil units exceeded their nominal design output. Detailed documentation of the thermal performance acceptance test results is summarized in Table S-4.

### Collector/Storage Subsystem

As shown in Table S-4, the collector subsystem performance was in excellent agreement with design values. Solar energy collection rate and collector efficiency exceeded predictions.

### CHILLER OUTPUT TEST DATA

CHILLED WATER TEMP = 41 — 50 F

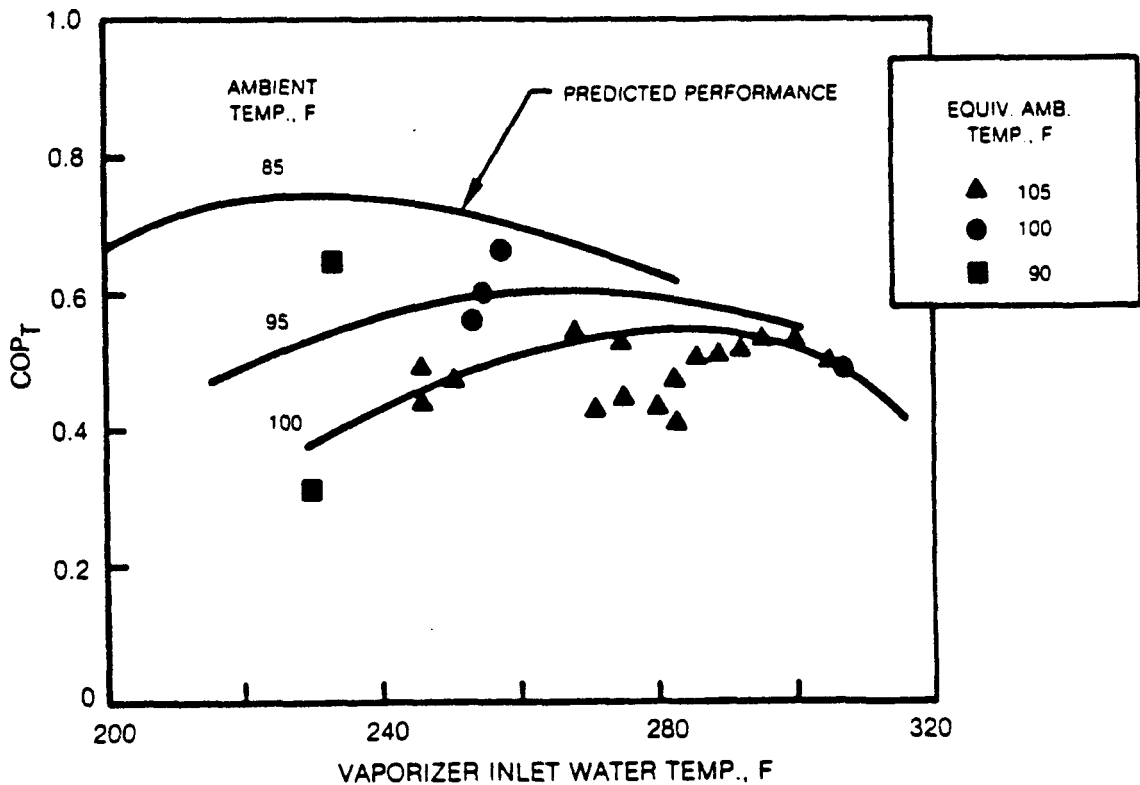
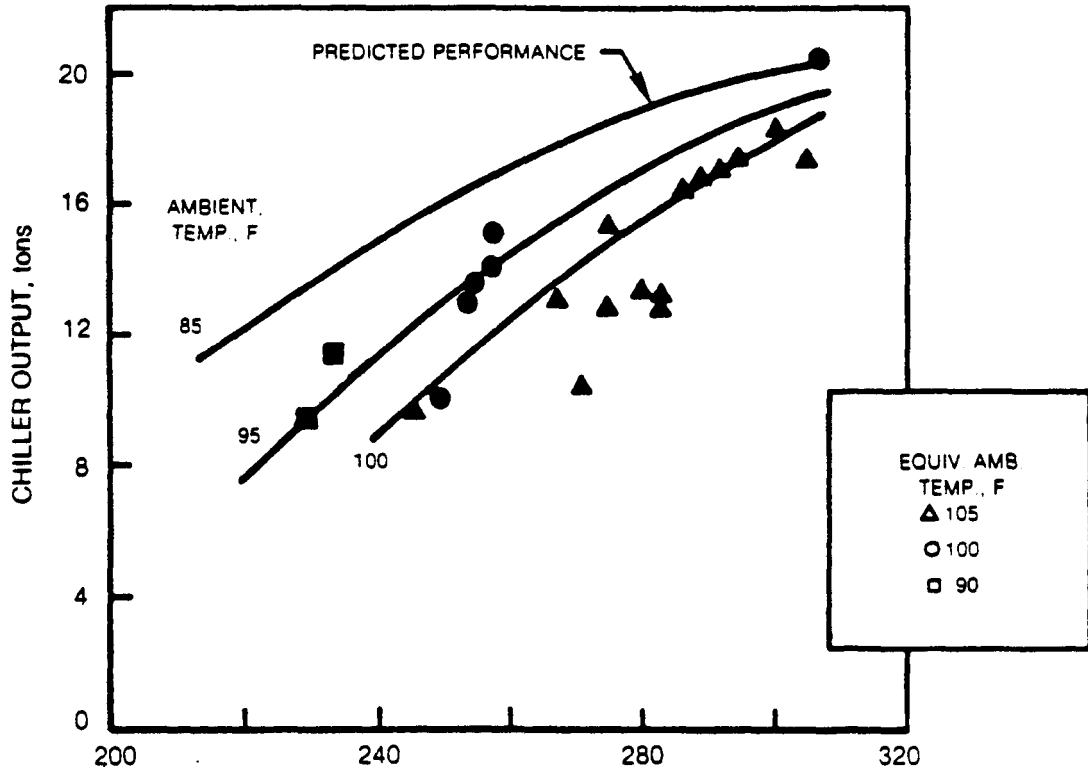

TABLE S-4

## THERMAL PERFORMANCE ACCEPTANCE TEST RESULTS

April 1, 1981

| <u>Subsystem</u>            | <u>Test Conditions</u>                                     | <u>Performance</u>   |             |                             |             |               |      |      |
|-----------------------------|------------------------------------------------------------|----------------------|-------------|-----------------------------|-------------|---------------|------|------|
|                             |                                                            | <u>Test</u>          |             | <u>Design</u>               |             |               |      |      |
| Collector/<br>Storage       | Clear Sky                                                  | $Q_o = 3328$ Btu/min |             | 3235 Btu/min                |             |               |      |      |
|                             | Direct Normal Insolation = 299.9<br>Btu/ft <sup>2</sup> hr | $T_{out} = 298$ F    |             | --                          |             |               |      |      |
|                             | Sun Angle $\theta = 25.8^\circ$                            | $\Delta T/I = 0.8$   |             | 0.8                         |             |               |      |      |
|                             |                                                            | $\eta_c = 57.6\%$    |             | 56% (flex-hose uninsulated) |             |               |      |      |
| <u>Chiller</u>              | $T_{VG}/T_{eq. amb.}/T_{e_o}, F$                           |                      |             | $Q_o, Tons/COP_T$           |             |               |      |      |
|                             | 308                                                        | 90                   | 54 F        | 22.1                        | 0.68        |               |      |      |
|                             | 300                                                        | 90                   | 51          | 20.5                        | 0.704       |               |      |      |
|                             | 284                                                        | 90                   | 47          | 19.3                        | 0.65        |               |      |      |
|                             | 287                                                        | 90                   | 44          | 17.5                        | 0.56        |               |      |      |
|                             | 240                                                        | 80                   | 54          | 15                          | 0.86        |               |      |      |
|                             | 5 hr operation average                                     |                      |             | 14                          | 0.55        |               |      |      |
| <u>Thermal Distribution</u> | <u>Unit Status</u>                                         |                      |             |                             |             |               |      |      |
|                             | <u>Evap. Pump</u>                                          | <u>FC-3</u>          | <u>FC-2</u> | <u>FC-1</u>                 | <u>Test</u> | <u>Design</u> |      |      |
|                             |                                                            |                      |             |                             | $Q_o, tons$ | GPM           | Tons | GPM  |
|                             | ON                                                         | ON                   | OFF         | OFF                         | 7.0         | 19            | 5    | 16   |
|                             | ON                                                         | OFF                  | ON          | OFF                         | 6.5         | 14            | 5    | 16   |
|                             | ON                                                         | OFF                  | OFF         | ON                          | 8.5         | 22            | 7.5  | 22.5 |
|                             | ON                                                         | OFF                  | ON          | ON                          | 10.5        | 32            | 12.5 | 38.5 |
|                             | OFF                                                        | ON                   | ON          | ON                          | 16.5        | 42.4          | 17.5 | 54.5 |

Chiller Module

Chiller performance results are listed in Table S-4 for the range of hot water temperatures supplied to the vapor generator. Chilled water temperatures ranged from 44 to 54 F with cooling output ranging from 15 to 22.1 tons. Coefficients of Performance of 0.56 to 0.86 were measured. The average for a full 5 hours of operation was 14 tons of cooling produced with an average COP of 0.55.

Thermal Distribution Subsystem

Test performance results for the building cooling subsystem listed in Table S-4 shows that individual fan/coils provided in excess of their rated tonnage with chilled water flow rates near design values. Performance with multiple units operating was below design values, but was rectified by a subsequent change to the cold water distribution plumbing.

## PHASE III - PROTOTYPE SYSTEM TESTING

Following completion of shakedown and acceptance testing of the installed prototype system, routine operation was initiated. The SOLERAS Program Office conducted a commissioning ceremony at the UTC installation on June 24, 1981. In attendance at this commissioning were Ambassador Holsey G. Handyside, Chairman SOLERAS Executive Board; Dr. Rida Obaid, Executive Director and Chairman of the Board of the Saudi Arabian National Center for Science and Technology; Bruce E. Babbitt, Governor-State of Arizona; Margaret T. Hance, Mayor-City of Phoenix, Mr. James F. Warnock, Jr. Executive Director-Arizona Solar Energy Commission; representatives of the U.S. Department of Energy and Treasury Department including Dr. Robert San Martin, several Saudi Arabian Universities, the SOLERAS program and the UTC program team. The completed installation was inspected by all of the commissioning ceremony guests, the press, and television as it operated through the day with the ambient temperature reaching ~ 114 F.

Operation was continued in the 1981 cooling season from April through mid-September and again in the 1982 cooling season from February through October. During this operation, the automatic Data Acquisition System recorded measurements of more than fifty (50) parameters to determine system status and performance. The data was stored on magnetic tape and processed by computer at UTRC to provide an assessment of the field test system operation.

### Operational Data Summary

As can be anticipated with a prototype system, this first engineering field test of continuous automatic operation disclosed some operational characteristics which were not observed in laboratory operation of individual components or subsystems and were not apparent during the system design process. Most of the operational problems encountered were rectified by relatively minor system modifications while some entailed appreciable time to diagnose and correct. A summary of significant events is presented in Table S-5. The effect of these events in terms of operating time can be seen by the comparison of actual and predicted operating times in Table S-6.

While some minor mechanical, hydraulic, or thermal problems were experienced the majority of difficulties involved electrical and/or control system elements. The multiplicity of control elements, the retrofit nature of the installation, the degree of instrumentation required for data gathering and recording, and application of immature design configurations are probable factors contributing to this result.

### System Performance Summary

During the first cooling season (1981) the system was operated for five months, and in 1982 nine months of operation were completed. A summary of the more significant performance parameters is provided in Table S-6. The chiller On Time in 1981 totaled 341 hours or 82 percent of predicted operating time. In 1982 a total of 295 hours of chiller On Time was logged which is approximately 48 percent of predicted operation. This lower than anticipated On Time was the result principally, of the time required to correct collector control system problems in March and April, and to refurbish the turbocompressor in August of 1982.

Measured collector instantaneous efficiencies compare reasonably well with predictions and no significant changes were noted over the two seasons of operation in spite of observed problems of minor delamination of the collector reflector surfaces during the last four months of the 1982 season. The degree of delamination observed in July 1982 was less than 2 percent of the surface and remained stable for the remainder of the operating season.

Cooling provided to the Hamilton Test Systems building is tabulated in tons-hrs on a monthly basis in Table S-6 for both the solar system and the backup air conditioning system. While measurements of the contribution of the backup A/C are not available for the 1981 seasons, data for the 1982 season shows the solar contribution to be 54 percent, while a 70 percent contribution was anticipated. This shortfall may be attributed to the reduced chiller On Times experienced in March and April and again in August.

TABLE S-5

## EVENT SUMMARY

| <u>Year</u> | <u>Collector/Storage Module</u>                                                                                      | <u>Chiller Module</u>                                                                                                                                                      | <u>Distribution Module</u>                                                                                                        | <u>DAS Module</u>                                                                                  |
|-------------|----------------------------------------------------------------------------------------------------------------------|----------------------------------------------------------------------------------------------------------------------------------------------------------------------------|-----------------------------------------------------------------------------------------------------------------------------------|----------------------------------------------------------------------------------------------------|
| 1981        | Collector limit and overtravel switches replaced with improved model.                                                | Sporadic cavitation of R11 pump observed.                                                                                                                                  | Plumbing changed to add separate line to cold tank.                                                                               | Data logger recording of instantaneous and averaged data on single scan observed to be unreliable. |
|             | Expansion tank and lines insulated to reduce heat loss.                                                              | Subcooler installed in R11 pump inlet line to prevent cavitation.                                                                                                          | Check valve in evaporator outlet water line replaced with spring loaded closed model to prevent flow by-pass.                     | New components installed. <sup>1</sup>                                                             |
|             | Collector limit and overtravel switches again replaced with more rugged model.                                       | High pitch fan blades installed in condensers to increase cooling at high ambient temperatures.                                                                            | Center zone Aquaduct removed from Fan/coil #1 water line to allow full flow.                                                      | Contact closure output and analog circuit boards defective and replaced. <sup>1</sup>              |
|             | Collector water loop flow switch malfunctioned and replaced <sup>2*</sup>                                            | Turbocompressor expansion valve cleaned. Intermittent flow interruption noted.                                                                                             | Aquaduct removed from fan/coil #3 water line to provide maximum available flow.                                                   | Sporadic interruption of contract closure output signals induced chiller shutdowns. <sup>1</sup>   |
|             | Hot water loop makeup water pump failed and replaced. Original motor undersized. <sup>1</sup>                        | Power loop R11 tested for free chlorine. None detected.                                                                                                                    | Fan/coil water pump coupling slipping. Improperly tightened. Corrected. <sup>1</sup>                                              | Shutdown code recorder added to Modicom.                                                           |
|             | Expansion tank pressure transducer failed and replaced. Damaged by power line transients. <sup>2</sup>               | Bearing cooling flow solenoid valve failed, interrupting flow and inducing T/C shutdown due to seal over-temperature. Tip of valve poppet broke off and plugged flow path. | Electrical power failure to fan/coils and room thermostats. Fuse blown due to parallel non-air-conditioning electrical equipment. | DAS reprogrammed to change relay contact closure mode.                                             |
|             | Hot storage tank instrumentation wiring deterioration noted in hot/moist environment.                                | Valve replaced. <sup>1</sup>                                                                                                                                               |                                                                                                                                   | Chiller START and STOP algorithms incorporated, using pressure signals rather than temperature.    |
|             | RTD's malfunctioned and replaced. <sup>2</sup>                                                                       | Bearing cooling fluid accumulator leak repaired.                                                                                                                           |                                                                                                                                   |                                                                                                    |
|             | West collector local controller defective and replaced. <sup>2</sup>                                                 |                                                                                                                                                                            |                                                                                                                                   |                                                                                                    |
|             | Battery charger defective and replaced. <sup>1</sup>                                                                 |                                                                                                                                                                            |                                                                                                                                   |                                                                                                    |
|             | West collector row limit switches replaced. Separation between limit and overtravel switches increased. <sup>1</sup> |                                                                                                                                                                            |                                                                                                                                   |                                                                                                    |

\* Number of failure occurrences

TABLE S-5 (Cont'd)

## EVENT SUMMARY

| <u>Year</u> | <u>Collector/Storage Module</u>                                                                                                                                                                                                                                                                                                                                                                                                                                                                                                                                                                                                                                                                                                                                                                                                                                                                                                                                                                                                                                                                                                                                                                                                                                                       | <u>Chiller Module</u>                                                                                                                                                                                                                                                                                                                                                                                                                                                                                                                                                                                                                                                                                                                                                                                                                                                                                        | <u>Distribution Module</u>                                                                                                                                                                                | <u>DAS Module</u>                                                                                                                                                                                                                                                                                                                                                                                                                                                                                                      |
|-------------|---------------------------------------------------------------------------------------------------------------------------------------------------------------------------------------------------------------------------------------------------------------------------------------------------------------------------------------------------------------------------------------------------------------------------------------------------------------------------------------------------------------------------------------------------------------------------------------------------------------------------------------------------------------------------------------------------------------------------------------------------------------------------------------------------------------------------------------------------------------------------------------------------------------------------------------------------------------------------------------------------------------------------------------------------------------------------------------------------------------------------------------------------------------------------------------------------------------------------------------------------------------------------------------|--------------------------------------------------------------------------------------------------------------------------------------------------------------------------------------------------------------------------------------------------------------------------------------------------------------------------------------------------------------------------------------------------------------------------------------------------------------------------------------------------------------------------------------------------------------------------------------------------------------------------------------------------------------------------------------------------------------------------------------------------------------------------------------------------------------------------------------------------------------------------------------------------------------|-----------------------------------------------------------------------------------------------------------------------------------------------------------------------------------------------------------|------------------------------------------------------------------------------------------------------------------------------------------------------------------------------------------------------------------------------------------------------------------------------------------------------------------------------------------------------------------------------------------------------------------------------------------------------------------------------------------------------------------------|
| 1982        | Collector master controller circuit board defective. Replaced. <sup>1</sup><br>Abnormally high battery charger current noted.<br>Hot storage tank demand thermocouple and RTD failed. Replaced. <sup>2</sup><br>Hatch cover insulated and sealed.<br>Hot tank exposed top cleaned, insulated and sealed to prevent corrosion and heat loss.<br>Batteries replaced with heavy duty type.<br>Battery charger and collector local controller diodes failed and replaced. <sup>2</sup><br>Collector water loop flow switch defective, replaced by reed type. <sup>1</sup><br>Local controlled power transistors failed. Circuit boards replaced. <sup>2</sup><br>Collector water loop flow switch erratic operation. Repaired and cleaned. <sup>1</sup><br>West bank local controller power transistors failed. <sup>1</sup> Apparent overload due to cycling with erratic flow switch signals. <sup>1</sup><br>Flow switch failed. Replaced by differential pressure switch.<br>Failure due to continuous exposure to high temperatures.<br>Collector reflective surface delaminations noted. Negligible performance impact.<br>Collector local controller board defective. EPROM integrated circuits replaced. <sup>1</sup><br>Collector reflective surface delaminated areas repaired. | Turbocompressor heat shield modified to adjust inboard lead seal temperature. New shaft face seal installed with higher spring force. Lower capacity (1/4 ton) expansion valve installed in bearing feed system.<br><br>Condenser fan blade changed. Installed 3 low pitch and 2 high pitch blades on each condenser. Low pitch fans operate at low ambient temperature for power reduction.<br><br>Bearing cooling expansion valve clogged, interrupting flow. Subsequently cleared itself. <sup>1</sup><br><br>Compressor outlet flange leaked. Corrected by tightening bolts. Fluid loss replaced. <sup>1</sup><br><br>Turbocompressor abnormal noise and vibration noted. T/C removed for service and balancing. Reinstalled. <sup>1</sup><br><br>Power loop blowout disc ruptured. Rll charge lost. Disc failed due to corrosion. No excessive overpressure occurred. Disc not needed and not replaced. | Evaporator chilled water bypass through non-operating fan/coils noted.<br><br>Solenoid shut-off valve incorporated in each fan/coil water line to preclude chilled water bypass with fan/coil turned off. | Modicon reprogrammed to limit chiller operation to high output/high performance regime.<br><br>Modicon program revised to change manual start sequence/ bearing pump controlled by accumulator pressure/time delays revised and some deleted.<br><br>Cassette data recorder failed and repaired. <sup>2</sup><br><br>New chiller START/STOP algorithms incorporated. Simpler function using fewer inputs.<br><br>Human error in programming caused T/C cycling with approximately 2 minute frequency. Error corrected. |

TABLE S-6

## FIELD TEST SYSTEM PERFORMANCE SUMMARY

|                                | 1981                       |               |               |               |                | 1982           |                |                |                |                | Totals         |               |                |                          |                     |
|--------------------------------|----------------------------|---------------|---------------|---------------|----------------|----------------|----------------|----------------|----------------|----------------|----------------|---------------|----------------|--------------------------|---------------------|
|                                | April                      | May           | June          | July          | Aug            | Feb            | March          | April          | May            | June           |                | July          | Aug            | Sept                     | Oct                 |
| <b>System Operation</b>        |                            |               |               |               |                |                |                |                |                |                |                |               |                |                          |                     |
| • Chiller On/Up Time           | .20<br>(.23) <sup>2</sup>  | .38<br>(.305) | .50<br>(.428) | .51<br>(.480) | .58<br>(.467)  | .073<br>(.039) | .268<br>(.153) | .392<br>(.23)  | .575<br>(.305) | .240<br>(.428) | .269<br>(.480) | *<br>(.467)   | .428<br>(.403) | * <sup>1</sup><br>(.320) |                     |
| • Chiller On Time,<br>Hrs      | 30<br>(50.6) <sup>2</sup>  | 43<br>(64.0)  | 88<br>(94.1)  | 55<br>(105.5) | 125<br>(102.7) | 13<br>(7.9)    | 10.2<br>(35.3) | 14<br>(50.6)   | 68<br>(64.0)   | 32<br>(94.1)   | 32<br>(105.5)  | 13<br>(102.7) | 78<br>(88.7)   | 34.4<br>(67.2)           | 689.4<br>(1032.9)   |
| <b>System Performance</b>      |                            |               |               |               |                |                |                |                |                |                |                |               |                |                          |                     |
| • Collector<br>Efficiency      | .55<br>(.502) <sup>2</sup> | .46<br>(.508) | .48<br>(.532) | .38<br>(.533) | .49<br>(.517)  | .587<br>(.451) | .381<br>(.475) | .449<br>(.502) | .480<br>(.508) | .453<br>(.532) | .499<br>(.533) | *<br>(.517)   | .495<br>(.515) | *<br>(.480)              |                     |
| • Cooling Provided,<br>Ton-Hrs |                            |               |               |               |                |                |                |                |                |                |                |               |                |                          |                     |
| Solar                          | 450                        | 568           | 678           | 330           | 1000           | 38.6           | 58.1           | 167            | 733            | 447            | 463            | 150.2         | 631            | 291                      | 2978.9 <sup>3</sup> |
| Backup A/C                     | *                          | *             | *             | *             | *              | 61.2           | 289.5          | 220            | 187            | 322            | 518            | 574.5         | 262            | 64                       | 2508.2 <sup>3</sup> |
| Total                          |                            |               |               |               |                | 99.8           | 347.6          | 387            | 920            | 769            | 981            | 724.7         | 893            | 355                      | 5487.1 <sup>3</sup> |
| • Chiller COP                  | .56                        | .49           | .38           | .37           | .36            | .38            | .37            | .50            | .28            | .30            | .42            | *             | .41            | *                        |                     |

<sup>1</sup> \* Indicates detailed DAS data not available

<sup>2</sup> TRNSYS program predicted values which yield an annual solar contribution of 70%

<sup>3</sup> Totals for 1982 season only

It must be noted that total measured cooling provided to the building is significantly less than originally predicted. Measured values for the summer of 1981 were about half of the predicted level and for 1982 were generally less than half the prediction. Several reasons appear to be contributing factors: 1) the weather conditions in the Phoenix area during the 1982 ten month operating period were cooler than normal requiring less cooling; 2) building occupancy was lower than assumed by the prediction program (i.e., fewer personnel and lower lighting and equipment usage result in less cooling demand); 3) thermostat settings selected by building occupants were generally higher than predicted (78 F or higher) again reducing the cooling demand; and 4) finally, it must be recognized that the TRNSYS simulation is an imperfect model of the field test situation and may be deficient in some details whose impact is not adequately recognized.

Comparison of typical performance data taken near the end of the second cooling season with corresponding data taken during checkout and acceptance testing indicates no significant degradation of performance when operating at comparable conditions.

An overall summary of performance for the two cooling seasons is presented in Table S-7. Total chiller On Time for two years operation in the field test is seen to be 67 percent of the predicted value and average chiller output was approximately 84 percent of that anticipated.

TABLE S-7

## UTRC SOLERAS SOLAR COOLING SYSTEM

Performance Summary for Period March 31, 1981 to October 31, 1982

| <u>System Operation</u>        | <u>Measured (Calculated)</u> |          |
|--------------------------------|------------------------------|----------|
| • Chiller ON/UP Time           | 0.227                        | (0.340)  |
| • Chiller On Time              | 689.4                        | (1032.9) |
| <u>System Performance</u>      |                              |          |
| • Collector Efficiency         | 0.475                        | (0.508)  |
| • Chiller COP                  | 0.393                        | (0.523)  |
| • Chiller Output, Average Tons | 9.45                         | (11.32)  |

## Reliability and Maintainability Summary

Examination of the number of failure occurrences listed in Table S-5 leads to the obvious conclusion that the reliability attained by the field test system was significantly below that predicted. A major contributor to this result appears to be misapplication of components to the particular subsystem. Such occurrences would be prevented in commercial systems by more extensive engineering design and development, which was beyond the scope of this prototype field test program. For example, the numerous collector control failures should be eliminated with a moderate development effort and increased production experience. Simple standard component failures caused by misapplication such as solenoid valves and RTD's have already been substantially reduced. The number of wear related or corrosion failures were predictably very small.

## INTRODUCTION

Saudi Arabia and the United States signed an agreement in October, 1977 for cooperation in the field of solar energy (SOLERAS) under the auspices of the United States-Saudi Arabian Joint Commission on Economic Cooperation. The objectives of the agreement are: (1) to cooperate in the field of solar energy technology for the mutual benefit of the two countries, including the development and stimulation of solar industries within the two countries; (2) to advance the development of solar energy technology in the two countries, and (3) to facilitate the transfer between the two countries of technology developed under this agreement.

A specific objective of the SOLERAS program is to promote the development of active solar cooling systems for urban areas in hot environments. This would decrease the dependence on depletable fossil fuels as well as reduce the deleterious environmental effects associated with the consumption of these fuels. To fulfill this objective, the Solar Energy Research Institute (SERI) awarded several contracts to further the development of active solar cooling systems for commercial applications with special emphasis on improving the performance figures of merit beyond the levels achievable by existing solar cooling systems. One of these contracts was awarded to the United Technologies Research Center (UTRC) with support from Hamilton Standard Division (HSD) of United Technologies Corporation (UTC). Midwest Research Institute was appointed operating agent for SERI.

UTC was an early advocate of solar-powered heating and cooling systems and was one of the first to demonstrate the performance, operational and reliability advantages of Rankine power cycle/Rankine cooling cycle systems designed for building applications. Hence UTC's approach to this program was to design, analyze and construct a Rankine-cycle solar cooling system and conduct an engineering field test of the system in a climate that simulates that of Saudi Arabia. For this application UTRC modified an existing prototype heat pump module designed, fabricated and tested under DOE funding (Solar Turbocompressor Heat Pump - STHP Contract No. AC 03-79-CS34510) for cooling use only (Ref. 1). This dual-loop Rankine-cycle power and Rankine-cycle cooling prototype unit utilizes a single working fluid (R11) and a high performance turbocompressor developed specifically for this application by the Hamilton Standard Division of UTC. This equipment is the result of 15 years of cooperative efforts by UTRC and HSD in the Rankine/Rankine air conditioning and heat pump field. The prototype heat pump has been operated in the laboratory with water-cooled condenser at condenser conditions simulating indirect air-cooling with a 95 F ambient air temperature and approached its predicted design output capacity of 18 tons with a thermal COP of 0.6. To achieve comparably good performance at higher ambient air temperatures encountered in the SOLERAS program, this (chiller) module was modified for direct air cooling by utilizing refrigerant air-cooled condensers.

The chiller module is one of three major subsystems that would comprise the overall cooling system installation. A solar collector/storage subsystem was utilized to collect energy from available sunlight to raise the temperature of the water stored in the hot tank. The stored hot water provides the source of thermal energy for either immediate or future use to drive the turbine in the chiller Rankine-cycle power loop. Since the chiller module was designed to operate efficiently at water temperature of 200 to 300 F an array of medium concentrating type collectors was employed. A thermal distribution subsystem was used to store and transport cold water generated in the chiller module to air handler/fan coil units to provide the building air conditioning.

The site selected for the engineering field testing of the solar powered cooling system is the Hamilton Test Systems (HTS) central office building located in Phoenix, Arizona. This report provides the rationale for selecting the site and an account of the contract program activities under Phase I - Solar Cooling System Design and Analysis, Phase II - Solar Cooling System Detailed Design, Construction and Installation and Phase III - Prototype System Testing.

The report is presented in six sections. The rationale for selecting the engineering field test site and the building cooling requirements are described in Section 1. Descriptions of the Phase I activities are presented in Sections 2 and 3. Section 2 provides descriptions of the overall cooling system and its major subsystems and components. Section 3 includes the preliminary design analyses conducted to select collector/storage, chiller module and thermal distribution components; operating features and estimated system performance. Phase II activities are presented in Sections 4 and 5. Detailed design, construction and installation features of the solar system at the test site are described in Section 4. Testing documentation is provided by the checkout and acceptance tests and their results are described in Section 5. Prototype system testing results are reported in Section 6, including operational, performance and reliability/maintainability results achieved in nearly two years of operation from March 1, 1981 to October 31, 1982.

An operating and maintenance manual prepared as part of the Phase II activities was issued as UTRC Report R81-955023-1 (Ref. 2). A final engineering and manufacturing documentation report was issued as UTRC Report R80-955017-7 (Ref. 3). An intermediate report of Phase I and II activities was issued as UTRC Report R82-955027-1 (Ref. 4).

Detailed engineering drawings of the equipment installed at the test site are available but are not included in this document.

## 1.0 SITE LOCATION AND BUILDING SELECTION

In order to fulfill objectives of the SOLERAS program it is necessary to conduct engineering field testing of a solar cooling system under environmental conditions of interest to Saudi Arabia. Although the test site was chosen as part of the proposal effort (UTRC P79-238), the rationale for selecting the particular site location and building and its cooling needs are described herein to provide the proper background to this program.

### 1.1 Site Location Selection

Saudi Arabian summer climate is characterized by high dry-bulb temperature and negligible precipitation. The three largest cities in Saudi Arabia have 2-1/2 percent summer design conditions as indicated in Table 1-1. The two coastal cities, Jeddah (on the Red Sea) and Dhahran (on the Persian Gulf) are both hot and humid, whereas Riyadh, the capital, is hot and dry. An examination of the summer design conditions for U. S. cities in the ASHRAE Handbook of Fundamental (1977) revealed that although a large number of locations in the southwestern United States have dry-bulb temperatures that equal or exceed those of the three major Saudi Arabian cities, none combines the high temperature and high humidity characteristics of Jeddah, and particularly, Dhahran. The cooling load characteristics of commercial office buildings in any hot climate will be fairly representative of those for similar office buildings in all three Saudi Arabian cities; because, outdoor air humidity affects only the ventilation and infiltration loads and these represent only a small fraction of an office building cooling load. Figure 1-1 depicts the psychrometric conditions of a number of hot U.S. locations in the states of Arizona, California, and Nevada where the dry-bulb temperatures exceed 100 F. It can be seen that the conditions in El Centro, Blythe, Needles and Palm Springs in the state of California, as well as Phoenix and Yuma in the state of Arizona are fairly close to the conditions in Riyadh. The city of Phoenix is of particular interest because its average summer conditions (dry bulb and daily range) are very close to those of Riyadh as indicated in Table 1-2. These average weather conditions were also confirmed by examination of the hour-by-hour climate conditions for Phoenix as provided by the SOLMET weather data tape.

### 1.2 Building Selection

An extensive screening of office buildings owned or leased by United Technologies and its subsidiaries was undertaken to identify those buildings that would best serve the purpose of the engineering field test of a solar cooling system. Several such buildings exist in the states of Arizona, California and Nevada. The most suitable of these is the headquarters office building of the Hamilton Test Systems (HTS) in Phoenix, Arizona.

TABLE 1-1

## SUMMER DESIGN CONDITIONS FOR THREE MAJOR CITIES IN SAUDI ARABIA\*

| City    | Latitude/<br>Longitude | Elevation,<br>ft | Design DBT,<br>F |     | Daily Range,<br>F | Design WBT,<br>F |     |
|---------|------------------------|------------------|------------------|-----|-------------------|------------------|-----|
|         |                        |                  | 1%               | 2½% |                   | 1%               | 2½% |
| Dhahran | 26°17'N/<br>50°09'E    | 80               | 111              | 110 | 32                | 86               | 85  |
| Jeddah  | 21°28'N/<br>39°10'E    | 20               | 106              | 103 | 22                | 85               | 84  |
| Riyadh  | 24°39'N/<br>46°42'E    | 1938             | 110              | 108 | 32                | 78               | 77  |

\* Taken from ASHRAE Handbook of Fundamentals, 1977.

# SUMMER DESIGN PSYCHROMETRIC CONDITIONS FOR POTENTIAL FIELD TEST SITES IN USA

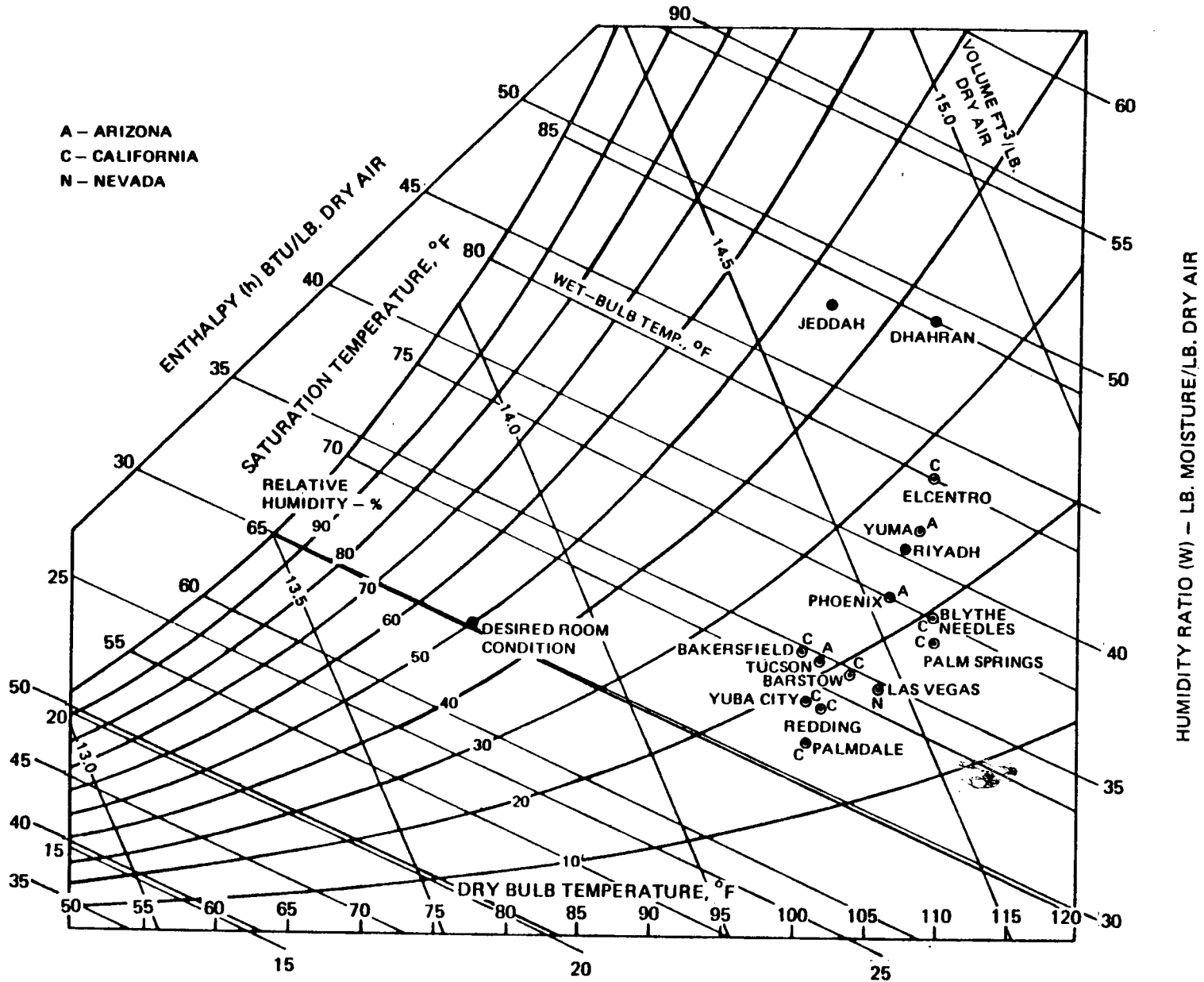

1-3

83-2-59-3

FB2-955027-2

FIG. 1-1

TABLE 1-2

## SUMMER DESIGN CONDITIONS FOR THE CITY OF PHOENIX, ARIZONA \*

(Lat. 33°3'N, Long. 112° 0'W, Elev. 1117 ft)

|                        | 1%  | 2½% |
|------------------------|-----|-----|
| Design DBT, F          | 109 | 107 |
| Mean Coincident WBT, F | 71  | 71  |
| Design WBT, F          | 76  | 75  |
| Daily Range, F         | 27  | 27  |

---

\* Taken from ASHRAE Handbook of Fundamentals, 1977.

Hamilton Test Systems, a subsidiary of United Technologies, is responsible for establishing and conducting (under long-term contracts) a unique environmental protection program for the states of Arizona and California. HTS operates 12 motor vehicle inspection (MVI) computerized facilities in Arizona which include testing of exhaust emissions. The headquarters for this program is located in a 7000 ft<sup>2</sup> single-story office building at 2303 East Thomas Road in the north-eastern section of Phoenix. Figure 1-2 contains several photographs of the building showing its northern, southern and eastern exposures. The building was constructed in 1975 and is owned by the Gosnell Development Corporation of Phoenix who leases it to HTS. As shown in Figs. 1-3 and 1-4, this building is located in a densely populated commercial area of the city next to the Granada Royale Hometel. The owners of the building granted UTRC permission to use the building for the engineering field test program.

### 1.3 Description of Building

A plan view of the HTS office building and of the surrounding buildings is shown in Fig. 1-4 and pertinent building data are provided in Table 1-3. About 6000 ft<sup>2</sup> of open lawn area was available behind the building (south end). This area receives direct solar radiation from about 7 a.m. to sunset in the summer months (the Granada Royale Hometel, also owned by Gosnell Development Corporation, located about 200 ft to the east, shades the back lot from sunrise till about 7.a.m.). This back lot, therefore, constituted the ideal location for the solar collector field.

Figure 1-5 is a plan view of the internal partitioning of the building, showing the existing air conditioning and duct systems. All the windows are both internally and externally shaded. The external shading is effected by about 4 ft of roof overhang as well as numerous trees and shrubs. The windows are internally shaded by means of semitransparent curtains. All the external walls have a full-width (3-1/2 in.) insulation and are finished externally with a layer of stucco. The roof is insulated by means of 6 in. fiberglass batts and is separated from the acoustic tile ceiling by means of an air space through which the air ducts run.

### 1.4 Air Conditioning Needs

Several approaches were taken to assess the true air conditioning needs of the build and to determine how well they could be satisfied by use of the UTC prototype turbocompressor solar cooling system (nominally 18 tons). The building load was identified by (1) the ratings of the existing electric air-conditioners, (2) simple ASHRAE published check figures which give average loads for various types of buildings (e.g., office), (3) calculations using the ASHRAE CLTD method and (4) by transfer function/dynamic simulation (TRNSYS) analysis.

HAMILTON TEST SYSTEMS BUILDING FIELD TEST SITE

FRONT VIEW

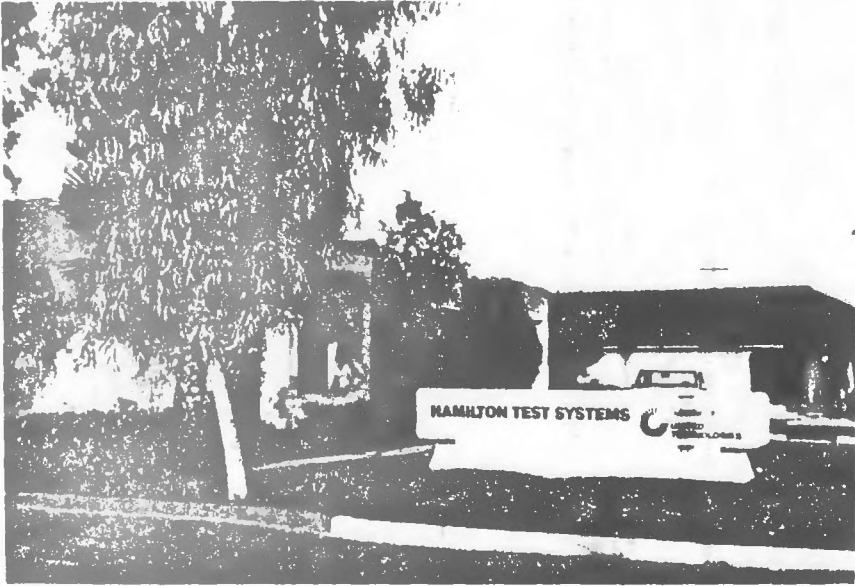

REAR VIEW

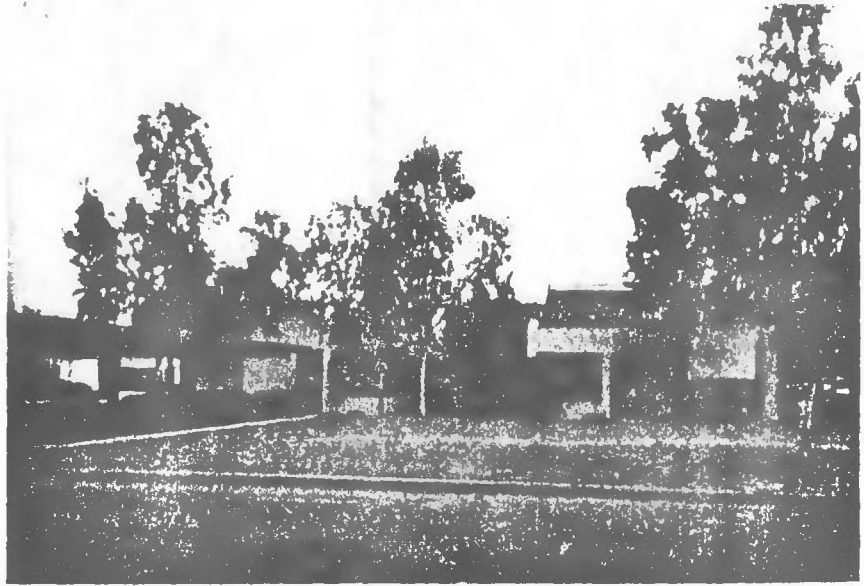

1-6

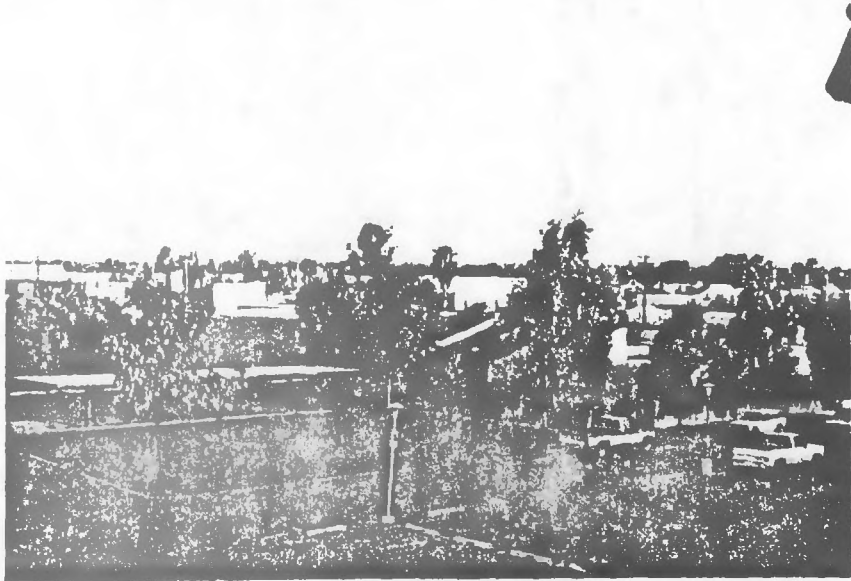

ELEVATED REAR VIEW

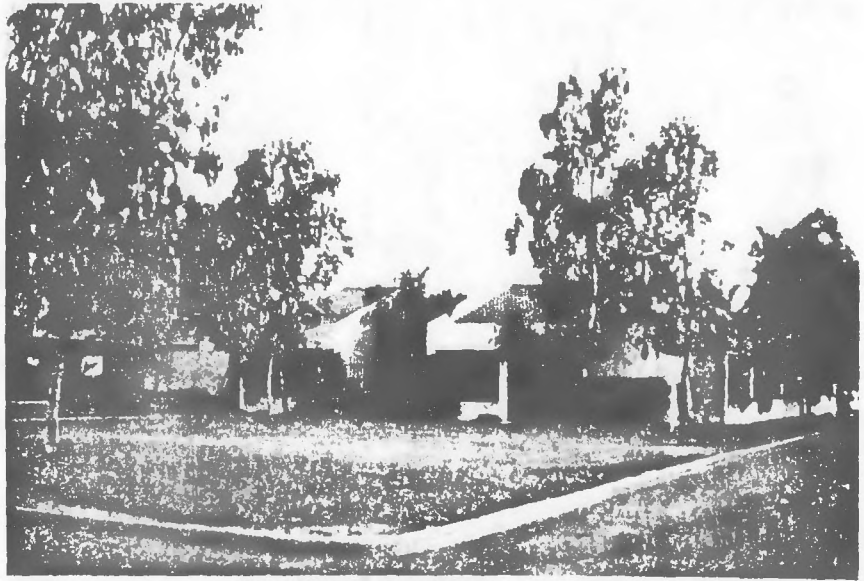

PROPOSED CAR PORT LOCATION

79-08-59-12

R82-955027-2

FIG. 1-2

HTS BUILDING TEST SITE LOCATION

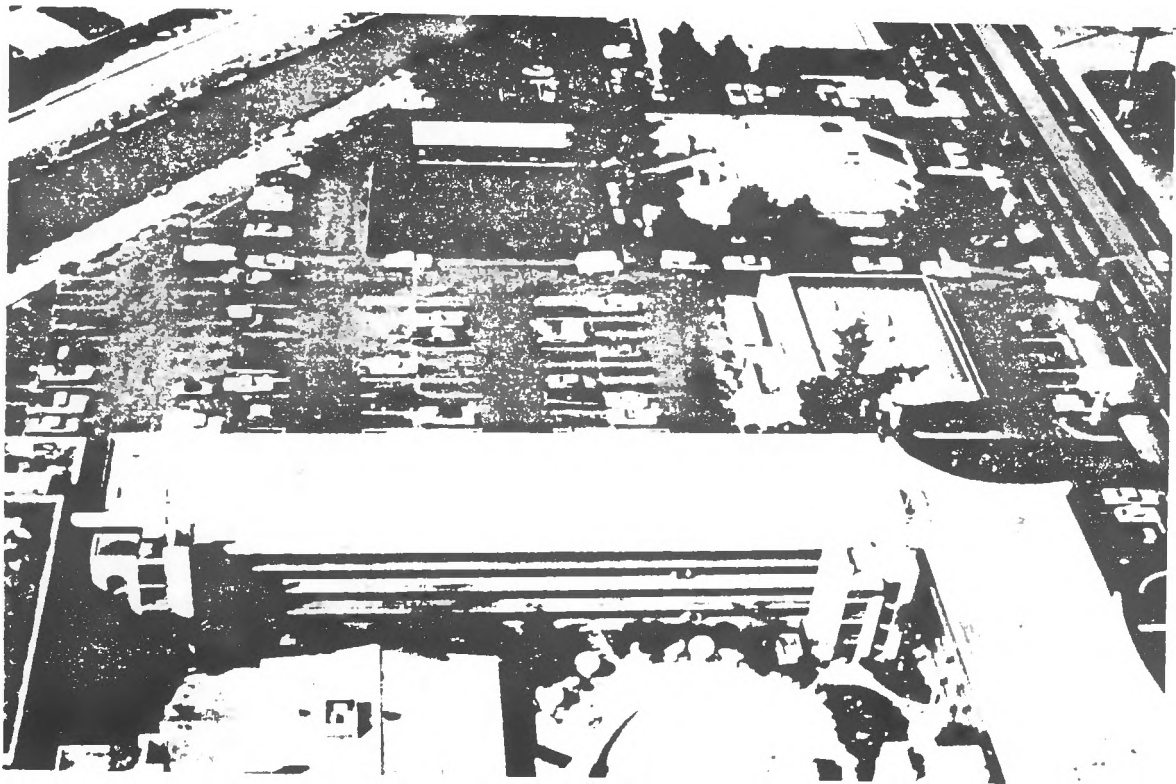

# FIELD TEST SITE DEVELOPMENT PLAN

SCALE AS SHOWN  
SCALE 1" = 100'

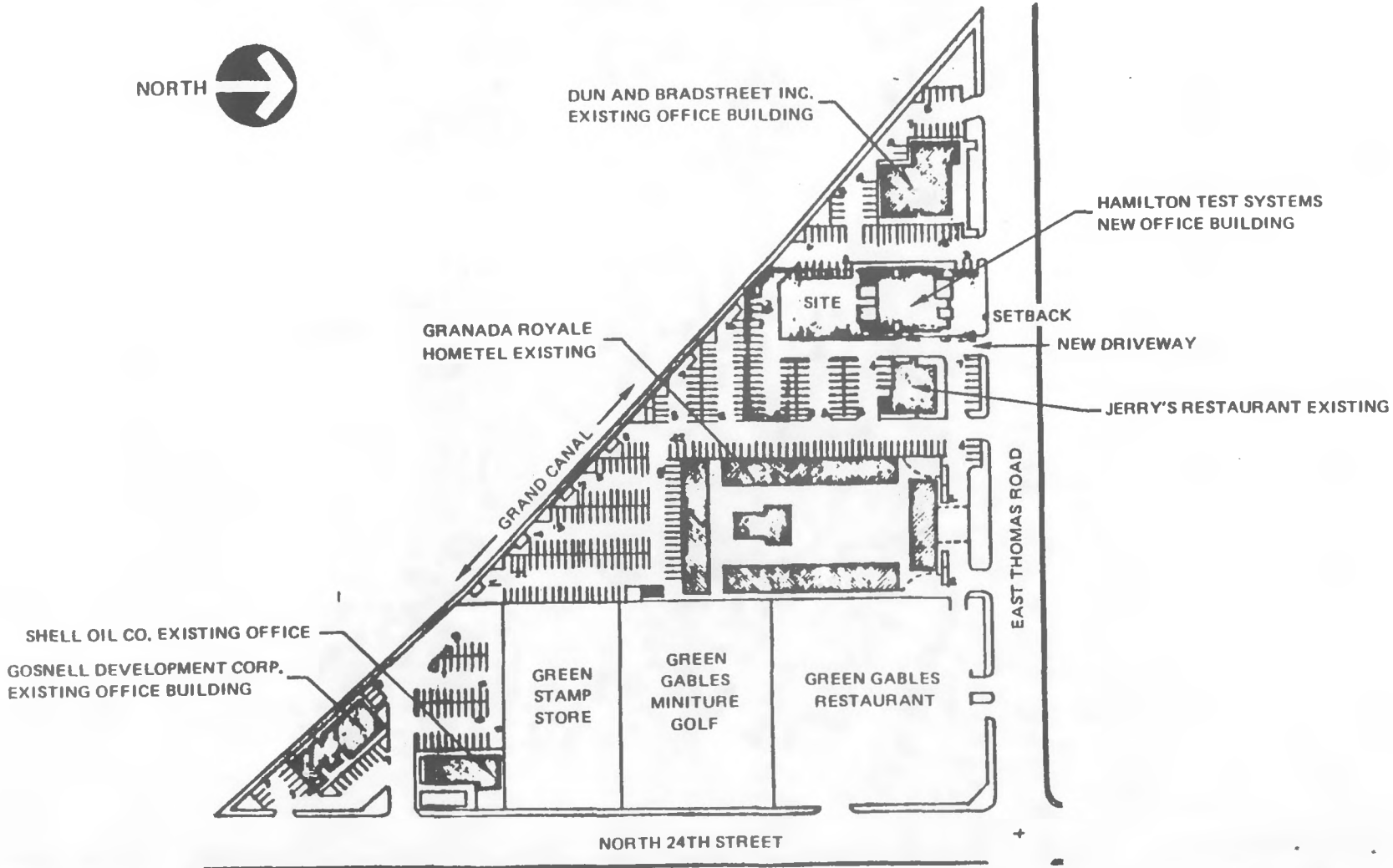

1-8

83-2-59-4

FIG. 1-4

TABLE 1-3

SUMMARY OF BUILDING DATA

Location: 2303 East Thomas Rd., Phoenix, Arizona

Function: Office building for Hamilton Test Systems

Owner: Gosnell Development Corporation  
2728 North 24th St., Phoenix, Arizona

Date Built: 1975

Type of Construction: One-story, wood frame with stucco finish

Plan Area: 7000 ft<sup>2</sup> (approximately)

Occupancy: 30 office workers

Air Conditioning System: Six roof-top units totaling 30.5 tons  
(4 x 5 + 1 x 7.5 + 1 x 3 tons) +  
air distribution system

Heating System: Electric resistance heaters installed in ducts

Air Conditioning Units to be Replaced by Solar System: 2 x 5 + 1 x 7.5  
tons (17.5 tons)

Back-up System to be Used with Solar System: Existing electrically driven units



Prior to the solar installation the building was air conditioned by means of six roof-top electric air conditioning units rated at a total of 30.5 tons comprised of four 5-ton units, a 7.5-ton unit and a 3-ton unit. Each of these units is controlled by a separate individual thermostat in a designated zone of the building. The 3-ton unit is dedicated to the computer room. Two 5-ton units and the 7.5-ton unit are located on the southern end of the building and supply cooling to approximately 60 percent of the building, as shown in Fig. 1-5. The combined rated capacity of these three units (17.5-tons) is approximately equal to the rated capacity of the UTC prototype turbocompressor solar cooling system (18 tons). Accordingly, the UTC solar cooling system would provide cooling to the areas served by these electric air conditioners. The existing HVAC ducting system would be utilized by both the solar cooling system and the existing electric air conditioners which would provide back-up cooling capacity. This simple configuration was selected to be the most economical for this field test installation, and provided accurate means of measuring the displaced cooling load and energy savings. It should be emphasized, however, that the use of electric A/C back-up systems is not generally advocated for all applications. The UTC solar cooling system would utilize an auxiliary furnace to provide back-up energy in locations where fossil fuels are economically available.

The HTS building requires a modest amount of heating in the coldest days of the winter which is provided by electric resistance heaters located within the duct system.

The air conditioning load based on simple ASHRAE check figures were in good agreement with the rating of the existing units at the 2 1/2 percent design condition. A more accurate figure determined by the ASHRAE CLTD method however indicated that the load is approximately 15 percent lower. As a final confirmation of the air conditioning load an hour-by-hour TRNSYS simulation was also performed. The preliminary design peak cooling load data are summarized in Table 1-4. It can be seen that only 5 percent of the load is due to humidity. This is typical of office buildings in hot climates as most of the load in this case is attributed to conduction through external surfaces, solar heat gain through fenestration, and, most importantly, lights and business machines. The only sources of humidity are people, ventilation and infiltration, which constitute a minor fraction of the total building load. Since the design load is predominately sensible, TRNSYS analyses indicated that comfort condition could be maintained with relatively high (approximately 50 F) fan-coil chilled water inlet temperatures. This temperature level is within the capability of the UTRC prototype chiller operating at high ambient temperatures. However, relatively large fan-coil units would be required. This TRNSYS calculation then confirms that the UTRC 18-ton solar unit would displace nearly 60 percent of the installed air conditioning capacity in the building.

TABLE 1-4

## PRELIMINARY DESIGN COOLING LOAD DATA

Indoor Design Conditions:

|                         |     |
|-------------------------|-----|
| Dry bulb temperature, F | 78  |
| Relative Humidity       | 50% |

Outdoor Design Conditions:

|                         |     |
|-------------------------|-----|
| Dry bulb temperature, F | 109 |
| Wet bulb temperature, F | 76  |

Ventilation

|                                |     |
|--------------------------------|-----|
| Number of air changes per hour | 1.1 |
| (about 30 CFM/person)          |     |

Cooling Load Estimates at 1% Design Conditions

|                                  |                |
|----------------------------------|----------------|
| Peak sensible load (4 pm), Btu/h | 310,000        |
| Peak latent load, Btu/h          | 18,000         |
| Sensible heat factor             | 0.95           |
| Total cooling load, Btu/h (tons) | 328,000 (27.3) |

The UTRC solar cooling system, therefore, constituted a practical alternative to the designated electric air conditioning units (2 x 5 + 7.5 tons) located near the southern end of the building. The UTRC system and the existing conventional system provide nearly the same capacity which is adequate for maintaining the building at comfortable conditions, even at the one percent ASHRAE summer design conditions for Phoenix.

The following sections (2 and 3) describe the efforts undertaken to define and specify the characteristics of the solar cooling system to be constructed, installed and field tested at the Phoenix site.

## 2.0 SYSTEM DESCRIPTION

The solar air conditioning system depicted in schematic form in Fig. 2-1 and designed for installation at the Hamilton Test System's central office building is comprised of three major subsystems. These are the solar collector/storage subsystem, the chiller module subsystem and the thermal distribution subsystem. The general features and functions of these subsystems are briefly described below. More detailed descriptions of these subsystems and their major components including the characteristics of the configurations finally selected for implementation are presented in subsequent sections of this report.

### 2.1 Solar Collector/Storage Subsystem

The solar collector/storage subsystem is comprised of an array of solar collectors, an insulated hot water storage tank, a circulating water pump and appropriate plumbing and valves. Water is circulated in a closed loop through the collectors absorbing energy from the available sunlight. When this water is heated sufficiently it is directed into the storage tank increasing the temperature of the water stored therein. When needed the stored hot water is transported to the chiller module by means of the vaporizer water pump.

### 2.2 Chiller Module

The chiller module consists of a Rankine-cycle engine driving a vapor-compression refrigeration unit as illustrated in Fig. 2-1. The operation of the chiller is as follows: hot water between selected temperatures (i.e., about 200 to 300 F) is supplied to the vapor generator from the storage tank to produce pressurized R11 working fluid vapor. The vapor is expanded through a single-stage, fixed-geometry radial inflow turbine. The low-pressure vapor leaving the turbine is condensed into liquid by rejecting heat via an air cooled condenser. The working fluid liquid is pumped back into the vapor generator by a motor-driven pump.

The turbine is coupled directly, through a shaft to a single-stage, fixed-geometry, centrifugal compressor in the vapor compression (refrigeration) loop. High-pressure R11 working fluid vapor leaving the compressor is condensed by rejecting heat in a second air cooled condenser. The liquid is then throttled to a low pressure by a float operated expansion valve. The low-pressure liquid is boiled in the evaporator by heat exchange with water which in turn is reduced in temperature. This chilled water is the source of the air conditioning. The working fluid vapor leaving the evaporator is directed to the compressor thus completing cycle.

### SOLAR COOLING SYSTEM

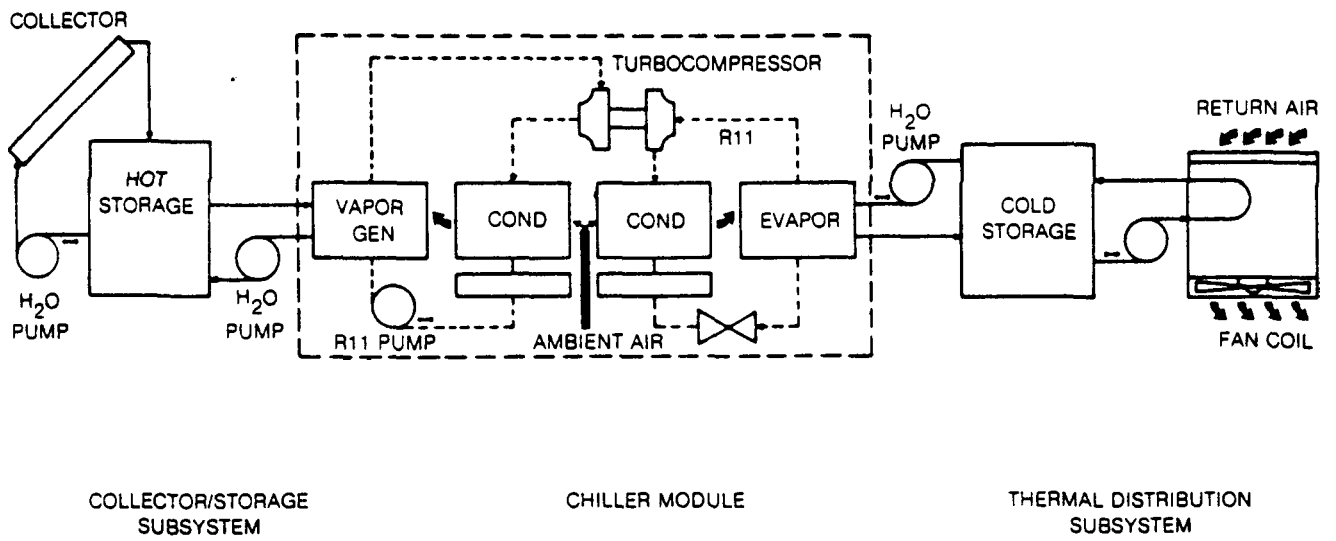

### 2.3 Thermal Distribution Subsystem

This subsystem consists of a cold water storage tank, circulating pumps, self-contained air handling fan-coil units and necessary plumbing and valves. When air conditioning is called for by the building thermostats, cold water is transported from the storage tank to the cold water coils in the air handling units. Air is forced over these coils to cool room return air which is distributed through the duct system. In this application, these air handling fan-coil units are hooked up in parallel with the backup electric air conditioners and utilize the existing distribution ducts as previously described.

### 3.0 DESIGN ANALYSIS

In this section the design features, estimated performance and preliminary component selections and specifications for the solar air conditioning system are described. System and component performance and trade-offs conducted to arrive at the system design and operating characteristics are also presented. A brief list of the major subsystems and components selected for this program are contained in Table 3-1.

The design features selected and general considerations which guided the analysis and selection process are described in the following paragraphs of this section. These features and general design considerations are based on previous UTC analyses and experimental efforts and standard practices adopted by the solar and HVAC industries. In order to limit risk and cost and to carry out this program in a timely manner, only those changes to the existing Solar Turbocompressor Heat Pump (STHP) module (Fig. 3-0) needed to insure efficient and reliable operation were made and the selection of any new equipment was limited to readily available commercial products. Additional design features and details can be found in subsequent sections of this report and in prior UTC reports and presentation brochures.

#### 3.1 Chiller Module Design and Selection

A detailed schematic drawing depicting the chiller module component arrangement selected for implementation is presented in Fig. 3-1. Its general design features and overall characteristics are summarized in Table 3-2. This module utilized much of the existing pallet, structure and heat pump (STHP) components with the following exceptions. The STHP shell-and-tube water-cooled condensers were replaced by remote air-cooled condensers located outside the building on the roof. Individual power-loop and refrigeration-loop liquid receivers were added. These were mounted on the pallet above the vaporizer and evaporator (Ref.: Dwg. UTRC 1749-10 Chiller Assembly). All vapor from the turbocompressor power and cooling loops flows to the corresponding condenser and liquid returns from the condensers to the receivers containing the freon charge for each loop. The liquid level in the receivers is maintained using the existing level controls. Additional modifications include a solenoid-type turbine inlet valve which replaces the pneumatic valve used in the STHP project, and a solenoid-type condenser bypass valve which is intended to prevent the turbocompressor from spinning backwards during the shutdown procedure (replaces the existing electric surge-bypass valve). An automatic purge unit was added to remove air and moisture from both the power and refrigeration freon loops. The purge unit consists of a control box, a purge dehydrator and two solenoid valves which are used to select either the power or refrigeration loop for purging according to a schedule programmed into the chiller control system. The water

TABLE 3-1

## MAJOR SUBSYSTEMS/COMPONENTS

|                      | <u>Description</u>                              | <u>Supplier</u>      |
|----------------------|-------------------------------------------------|----------------------|
| Chiller Module       | 18-ton Rankine/Rankine                          | UTC-UTRC/HSD         |
| Solar collector      | Parabolic trough                                | Suntec               |
| Storage              | Hot and cold water                              | Glendale Tank        |
| Air handler fan-coil | (2) 5-ton units<br>(1) 7.5-ton unit             | UTC-CARRIER          |
| Air Condenser        | (2) vertical airflow units<br>Direct drive fans | Larkin Coils, Inc.   |
| Controls             | Collector/chiller/space<br>conditioning         | Gould/Honeywell/UTRC |
| DAS                  | Mini computer with cassette<br>storage          | Acurex               |
| Backup system        | Electric roof-top A/C's                         | Carrier-Paine        |

# SOLAR POWERED TURBOCOMPRESSOR HEAT PUMP

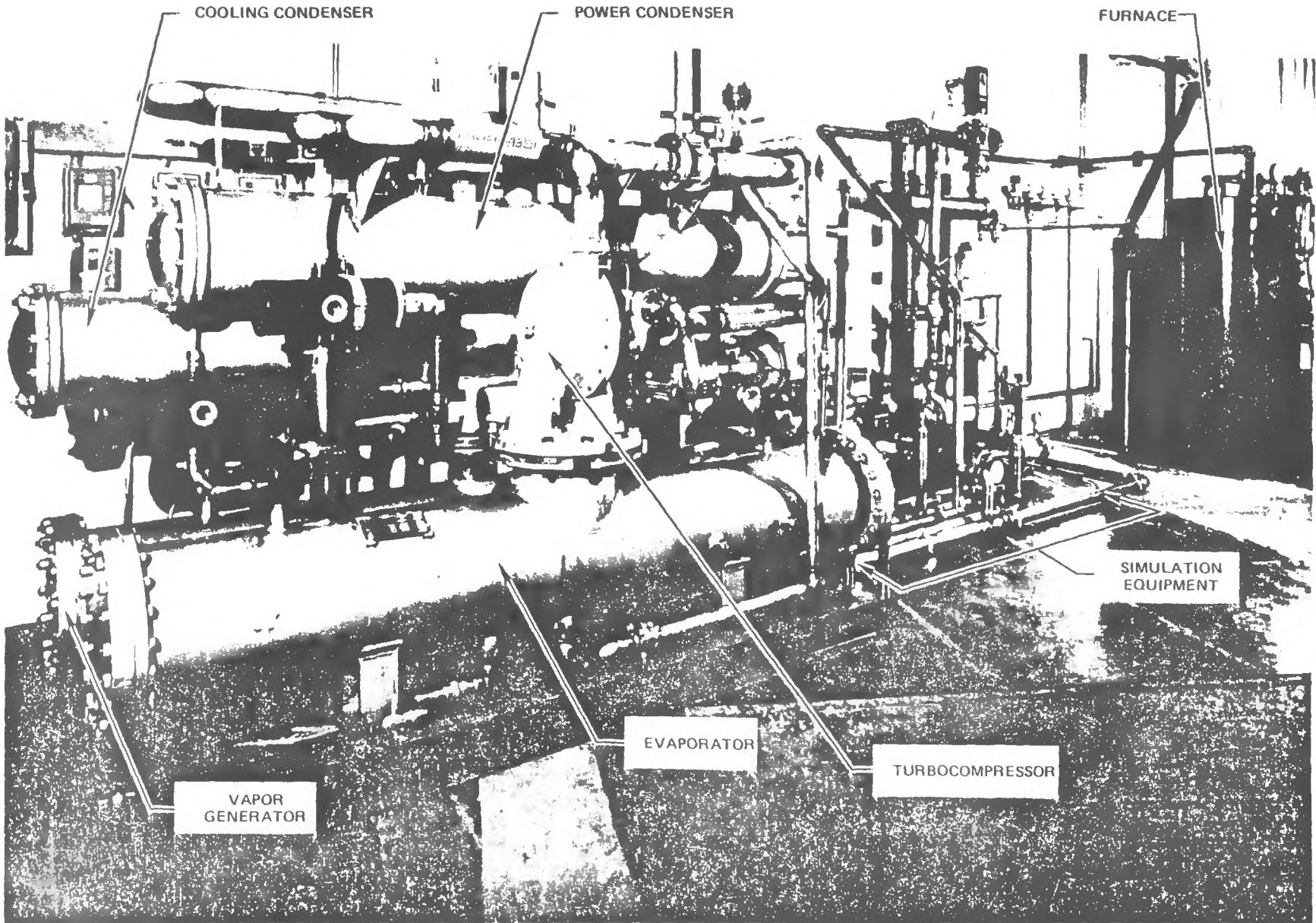

3-2b

79-05-71-4

R82-955027-2

FIG. 3-0

### CHILLER MODULE DETAIL SCHEMATIC

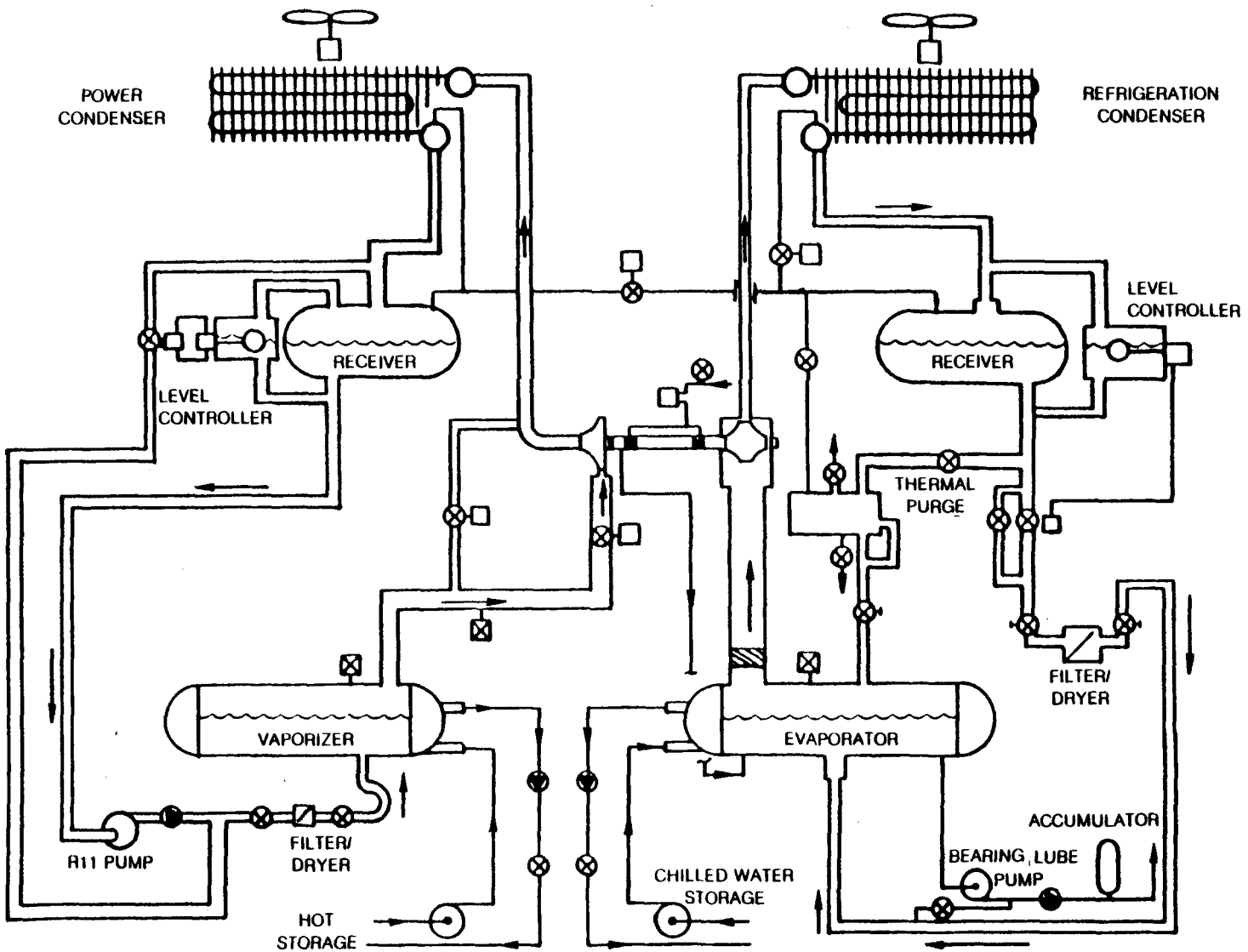

3-3

80-7-55-1

FIG. 3-1

TABLE 3-2

## CHILLER MODULE CHARACTERISTICS

|                         | <u>Description</u>                         | <u>Performance</u>                        | <u>Comments</u>                                                              |
|-------------------------|--------------------------------------------|-------------------------------------------|------------------------------------------------------------------------------|
| Design                  | Rankine power/<br>Rankine cooling          | Moderate                                  | DOE program module                                                           |
| Expander-<br>compressor | Turbine-<br>compressor                     | 78% turbine<br>85% compressor             | Test verified performance                                                    |
| Heat exchangers         | Patterson-Kelly<br>flooded, finned<br>tube | Low $\Delta T$ approach                   | Standard HVAC                                                                |
| Output                  | Chiller water                              | 40 to 60°F                                | Existing evaporator<br>configuration,<br>demonstrates multi-<br>zone feature |
| Cooling                 | Direct air<br>condensers                   | 95°F standard rating<br>107°F 2.5% design | Standard HVAC<br>refanned                                                    |

pumps for the evaporator and vaporizer employed as part of the UTRC laboratory facility in the STHP program were mounted on the pallet above the evaporator and vaporizer, respectively. The evaporator and vaporizer were raised and mounted 8 inches higher on the pallet in part to increase the head to the bearing feed pump which draws an oil rich mixture of freon from the evaporator. The final overall height of the chiller unit was less than 71 inches tall, providing 11 inches of vertical clearance at the HTS facility.

### 3.1.1 Air-Cooled Condenser Selection

A major modification to the STHP chiller module was replacement of the water-cooled condensers with remotely located air-cooled condensing units.

Several design features were considered and evaluated in selecting the air-cooled refrigerant condensers capable of providing a chiller nominal output of 18 tons. A large number of parallel refrigeration circuits are needed to limit R11 pressure drop which can adversely add to the compressor pressure ratio. Fan power must be limited since it can account for the majority of the chiller system electrical requirements. Yet the physical size is important because high and wide condensers can result in collector shading and/or can increase the width requirement of the carport. However, program schedule and cost limited the selection to standard commercial units which require relatively minor modifications such as changes in the refrigerant circuiting. Cost, performance and size specifications were obtained for several alternative air-cooled condensers and utilized in studies to select the best units for this application.

#### 3.1.1.1 System Performance with Alternative Air-Cooled Condensers

Analyses were conducted to evaluate the effect on system performance of several alternative configurations manufactured by Carrier, Larkin and Kramer-Trenton and the results are summarized in Table 3-3. Relatively little differences in system output capacity or thermal COP resulted from the use of these alternative condensers. However, there are significant differences in fan power due to differences in air face velocities, number of rows and fin and tube spacing utilized in the available units. It was estimated that large reductions in fan bhp which may be translated into reduced electric power consumption could be achieved easily in the field by substituting manufacturer-supplied fan blades with fans of the same diameter but with lower blade angles. The accompanying decrease in air flow, however, does reduce condensing capacity. Additional performance analyses were conducted to determine whether there may be a significant advantage in using different capacity (UA) condensers in the power and refrigeration loops. The results shown in Fig. 3-2 indicate that near optimum performance is achieved with units of equal capacity.

Based on the above performance analyses and cost, size and delivery characteristics of the alternative designs (see Table 3-4), two Larkin FCA-60 units were finally selected for this application.

TABLE 3-3

SOLAR COOLING SYSTEM PERFORMANCE WITH ALTERNATIVE  
AIR-COOLED CONDENSERS

| Condenser Options<br>Number of Units <sup>(1)</sup><br>and Model No. | High Temperature<br>Condition <sup>(2)</sup> | Typical Operating<br>Condition <sup>(3)</sup> | Total<br>Power<br>Consumption |
|----------------------------------------------------------------------|----------------------------------------------|-----------------------------------------------|-------------------------------|
| Power Loop/Cooling Loop                                              | Output, tons/COP                             | Output, tons/COP                              | kw                            |
| <u>Carrier</u>                                                       |                                              |                                               |                               |
| I. 09DE054/09DE054                                                   | 16.6/0.492                                   | -                                             | 8.0                           |
| II. 09DE054*/09DE054*<br>with 31,200 cfm each                        | -                                            | 18.3/0.686                                    | 4.3                           |
| III. (2)09DD028*/(3)09DD028*<br>with 16,000cfm each                  | 16.2/0.485                                   | 18.8/0.709                                    | 7.5                           |
| IV. (2)09DD028/(2)09DD028                                            | 16.4/0.484                                   | 18.5/0.691                                    | 17.2                          |
| <u>Larkin</u>                                                        |                                              |                                               |                               |
| V. FCA-60/FCA-60                                                     | 17.1/0.506                                   | 18.9/0.705                                    | 11.9                          |
| VI. FCA-60*/FCA-60*<br>with 34,160 cfm each                          | 16.59/0.491                                  | 18.7/0.697                                    | 6.4                           |
| VII. FCA-64*/FCA-47*<br>with 33,600 and 23,320 cfm                   | 16.6/0.493                                   | 18.9/0.710                                    | ~7.6                          |
| <u>Kramer-Trenton</u>                                                |                                              |                                               |                               |
| VIII. (2)DD-530/(2)DD-530                                            | 17.5/0.517                                   | -                                             | ~19                           |

| (1) Number of units used in UTC solar installation<br>Inlet temperatures, F | Vaporizer | Water/Condenser | Air/Evaporator | Water |
|-----------------------------------------------------------------------------|-----------|-----------------|----------------|-------|
| (2)                                                                         | 300       | / 110           | /              | 60    |
| (3)                                                                         | 270       | / 90            | /              | 60    |

\*Standard unit with reduced airflow

### AIR-COOLED CONDENSER UA SPLIT OPTIMIZATION

TOTAL UA = CONSTANT  
 $T_{VG} = 300F$ ;  $T_{AMB} = 110F$ ;  $T_{EVAP} = 60F$

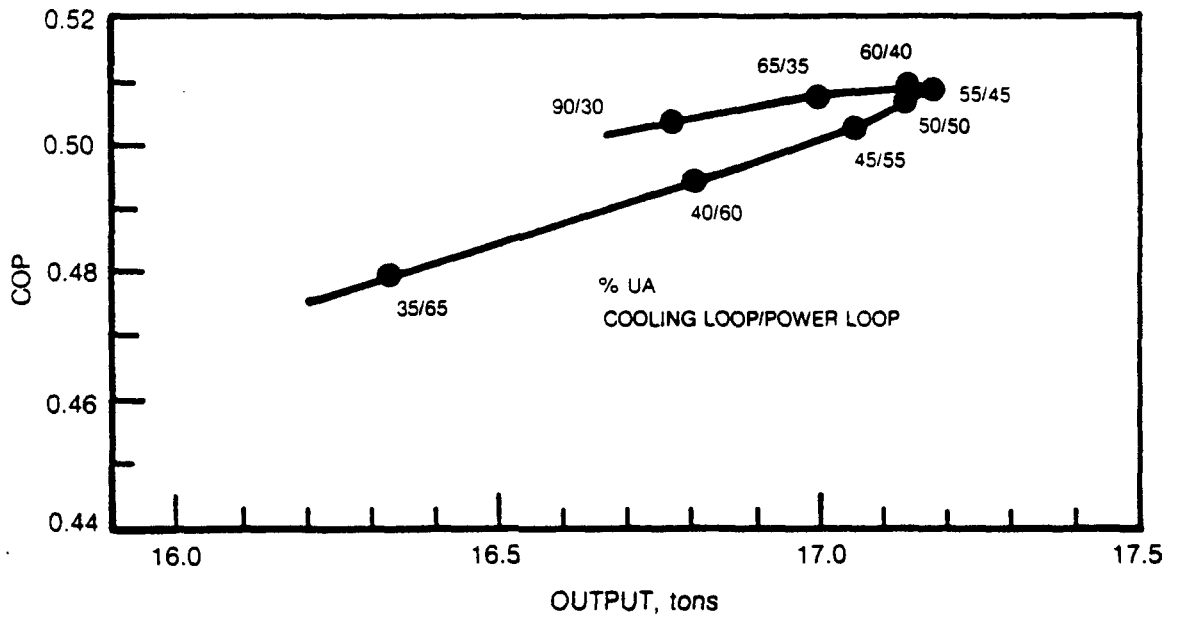

TABLE 3-4

## AIR-COOLED CONDENSER PERFORMANCE, SIZE AND COST COMPARISON

|                                           | Carrier              |                      | Larkin    |                    |                    | Kramer-Trenton     |
|-------------------------------------------|----------------------|----------------------|-----------|--------------------|--------------------|--------------------|
|                                           | 09DE054              | 09DD028              | FCA60     | FCA47              | FCA64              | DD-530             |
| Rating W/R11<br>@ 10 TD, MBH              | 229                  | 119                  | 261       | 211                | 289.6              | 111                |
| Airflow, cfm (rated)                      | 39,000               | 25,200               | 42,700    | 29,150             | 42,000             | 34,000             |
| Total Heat Transfer Area, ft <sup>2</sup> | 7700                 | 2600                 | 7800      | -                  | -                  | -                  |
| L/W/H, in.                                | 155x84x68            | 115x48x48            | 214x61x43 | 170x54x40          | 170x63x40          | 180x61x42          |
| R11 Pressure Loss <sup>(1)</sup> , psi    | 0.57                 | 0.77                 | 1.44      | 2.6                | 0.52               | -                  |
| Fan Power, kW                             | 4.0                  | 4.3                  | 5.95      | 4.8 <sup>(2)</sup> | 9.5 <sup>(2)</sup> | 4.8 <sup>(2)</sup> |
| Delivery, wks                             | 9                    | >10                  | 5         | 5                  | 5                  | Not Quoted         |
| Cost, \$/Unit                             | 5265 <sup>(3)</sup>  | 2760 <sup>(3)</sup>  | 3965      | 3147               | 4709               | 4851               |
| Cost/Capacity, \$/MBH                     | 23                   | 23.2                 | 15.2      | 14.9               | 16.3               | 43.7               |
| Fan Power/Capacity, kW/MBH                | 0.017                | 0.036                | 0.023     | 0.022              | 0.033              | 0.043              |
| Number Required <sup>(4)</sup>            | 2                    | 4                    | 2         | 1                  |                    | 4                  |
| Total Cost <sup>(4)</sup> , \$            | 10530 <sup>(3)</sup> | 11040 <sup>(3)</sup> | 7930      | 7856               |                    | 19404              |

(1) At 63 lb/min and 122 F

(2) Estimated from motor nameplate rating and fan cfm

(3) Includes recircuiting of standard units to remove subcooler section

(4) For UTC solar cooling system installation

Characteristics of the selected unit are summarized in Table 3-5 and its physical configuration is shown in Fig. 3-3. The rating (260 MBH at 10 F temperature difference) for each FCA-60 unit is based on the manufacturers design air flow rate of 42,700 cfm and an R11 condensing temperature of approximately 120 F and no subcooling. Condensing capacity is reduced when refitted with lower cfm fan blades. With a 20 percent reduction in cfm (i.e., @ 34,160 cfm) which can be achieved with the substitution of lower pitch blades, the fan power consumption for the two units should be 6.4 kW.

Each condenser is equipped with five 30-in. fans direct driven by 1 hp 230V/60/3 electric motors. When eventually installed, by mounting the two units in tandem, the small width and height would not require undue enlargement of the carport while avoiding shading of the solar collectors.

### 3.1.2 Receivers

A modified commercial receiver was selected for use in both the power and refrigeration loops. These receivers drain the R11 condensate from the air condensers to limit subcooling and thereby maximize the condensing capacity. They also serve as an accumulator of liquid at condenser pressure. The power receiver provides the means for maintaining a suitable liquid head to prevent cavitation of the power loop R11 pump and also provides a vapor space into which the pump bypass flow can be returned. The refrigeration loop receiver provides a source of liquid R11 for the expansion valve and the purge dehydrator. Both receivers also provide convenient locations for collecting the suction gases which are decontaminated in the purge unit. Each receiver (10-in ID x 36 in long) has sufficient capacity to hold the normal condenser operating charge which drains into the receiver during the off cycle and to insure stable operation of the level controllers. The ratio of liquid level charge in the receiver to that in the evaporator or vaporizer is approximately 3:1.

### 3.1.3 Purge Unit

The selected chiller module purge unit is a commercial product manufactured by Carrier Corporation for use on their large chiller systems. A schematic of the unit as incorporated in the chiller module is provided in Fig. 3-4. This unit which consists of two major components (#19CB116-214 purge box assembly and #19CB713-133 dehydrator assembly) automatically removes noncondensable gases from the R11 working fluid and concentrates water contaminants in the dehydrator for manual removal. The purge connections are normally open to refrigeration receiver liquid drain and gas vent lines as well as to the evaporator. Two solenoid valves are used to connect the power receiver vent to provide purging of the power loop while isolating the refrigeration receiver vent to limit the transfer of R11 between the refrigeration and power loops. Needle valves in the liquid and gas suction lines are adjusted to limit the R11 flow rates to the purge unit.

TABLE 3-5

FINAL SELECTION  
AIR-COOLED CONDENSER SPECIFICATIONS

|                       |                      |
|-----------------------|----------------------|
| Make & Model          | Larkin FCA-60        |
| Rating w/R11 & 10TD   | 260 MBH              |
| Number Required       | 2                    |
| <u>Air Side</u>       |                      |
| Flow Rate             | 42,700 cfm           |
| Face Area             | 62.5 ft <sup>2</sup> |
| Face Velocity         | 569 ft/min           |
| No. Fans/Diameter/rpm | 5/30 in./830         |

Coil

|                              |               |
|------------------------------|---------------|
| No. of Tube Rows             | 4             |
| Fin Spacing                  | 10 fpi        |
| Tube Spacing                 | 1.5 x 1.3 in. |
| Width                        | 54 in.        |
| Distance Between Tube Sheets | 200 in.       |
| No. Circuits Available       | 36            |

Fan Motors

|                      |         |
|----------------------|---------|
| Nema Rating, each    | 1 hp    |
| Total FLA @ 230 v.   | 25.0    |
| No. Phases/frequency | 3/60    |
| Power Consumption    | 5.95 kW |

Overall Dimensions

|        |             |
|--------|-------------|
| Length | 213 3/4 in. |
| Width  | 60 1/2 in.  |
| Height | 43 in.      |

Approximate Weight 1930 lb

Characteristics with Low-Pitch Fan Blades

|                                      |            |
|--------------------------------------|------------|
| Airflow                              | 34,160 cfm |
| Fan Power Consumption<br>(two units) | 6.4 kW     |

### LARKIN FCA-60 AIR-COOLED CONDENSER

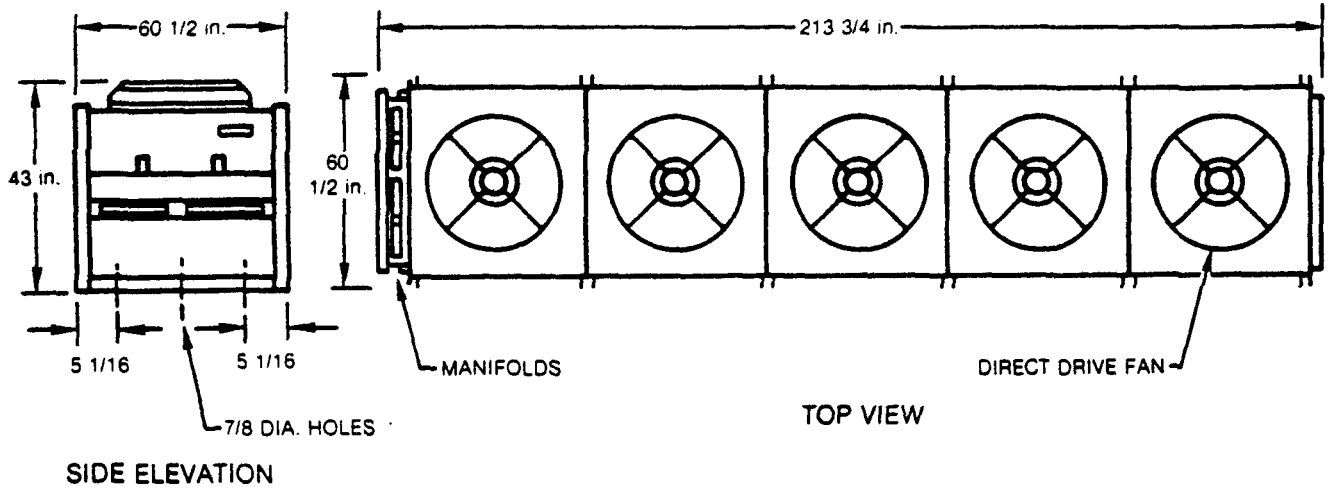

GAS CONNECTIONS — 2 AT  $1 \frac{5}{8}$  in.  
LIQUID CONNECTIONS — 2 AT  $1 \frac{5}{8}$  in.

### THERMAL PURGE UNIT SCHEMATIC

(RECOMMENDED INSTALLATION SPECIFICATIONS SHOWN)

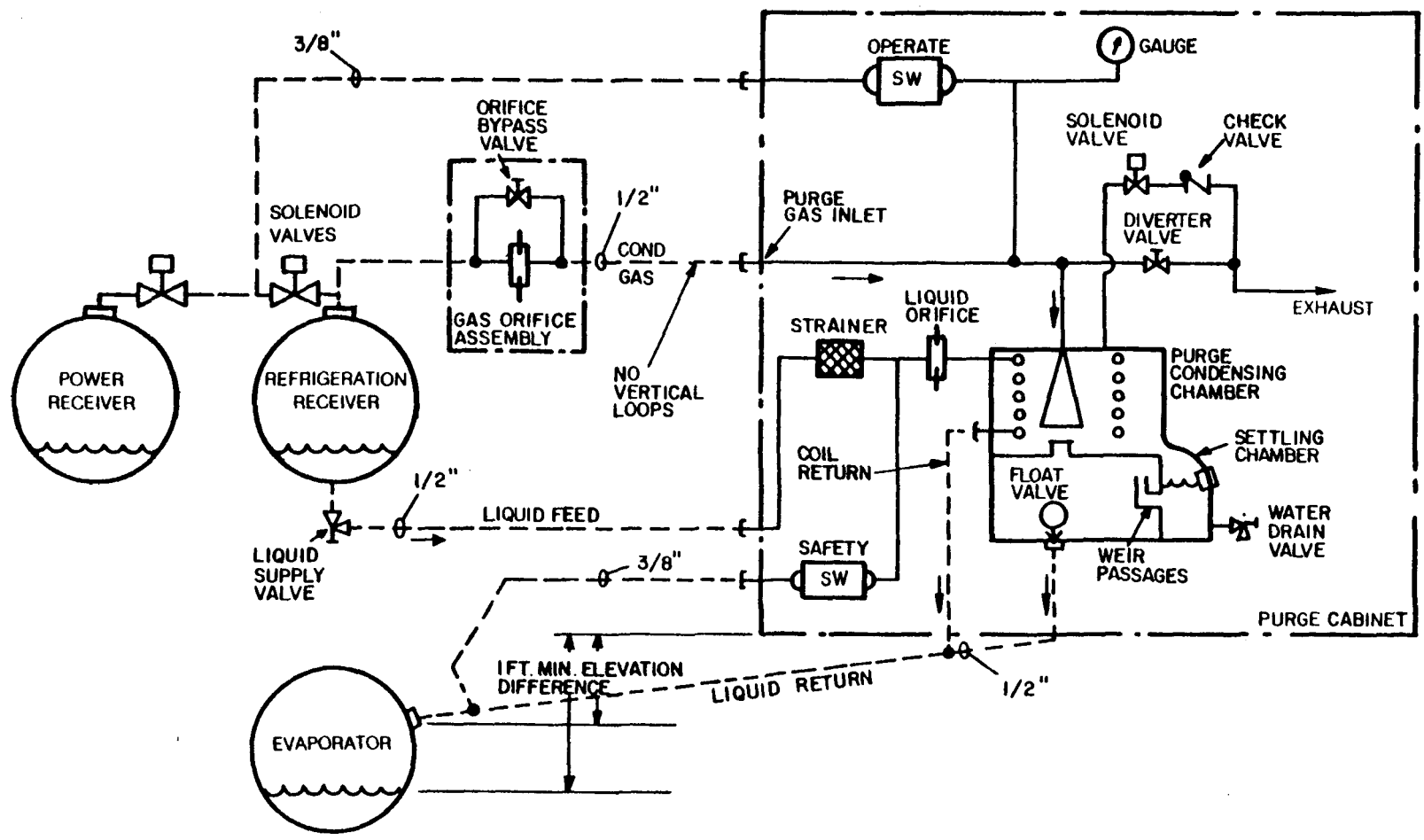

3-12

80-5-5-3

FIG. 3-4

### 3.1.4 Chiller Module Controls

For the SOLERAS installation, chiller module controls were modified in several areas from those utilized in the UTRC laboratory prototype heat pump installation. For laboratory testing, a modulating turbine inlet valve was used to allow evaluation of capacity modulation and a modulating compressor bypass valve was used to facilitate surge line definition and to control rotor assembly back-spin on shutdown. The design of these and other control functions are discussed below. Most of these control functions are accomplished by means of a microprocessor based programmable controller.

#### 3.1.4.1 Turbocompressor Control

Since cold storage is included in the installation, maximum cooling output for the available vaporizer inlet water temperature is optimal. Any excess capacity beyond that required by building load is stored and utilized later. Consequently, the turbine inlet control valve selected is a simple solenoid shut-off rather than the more complex modulating type.

With the compressor surge line defined, the approach to surge control for SOLERAS is to measure operating parameters which can be correlated to surge and to simply cease chiller operation when a surge condition is indicated, rather than continue operation with by-passed compressor flow and degraded machine efficiency. The surge condition is defined by analytical predictions. Thus, this function of the STHP surge control valve is eliminated. The second function--that of preventing back-spin on shutdown--is provided by a second solenoid shutoff valve. This valve is opened when the turbocompressor is to be shut down allowing equilization of cooling condenser and evaporator pressures and preventing the compressor from operation as a motor to drive the rotor assembly in reverse with possible detrimental effects on the bearings.

Other turbocompressor control elements remain as for the STHP module, i.e., a thermostatic expansion (TX) valve for bearing feed control and a speed pickup for speed measurement and overspeed cutoff. A minimum speed set point is also used to close a solenoid valve that stops the flow of bearing feed fluid to the turbocompressor TX valve during the shut down operation.

#### 3.1.4.2 Level Controls

Initial design of the power loop and cooling loop level controls utilized the same components as the STHP module. The float chambers, however, were mounted such that the liquid level in the appropriate receiver was controlled since the water-cooled condensers were replaced by remotely located air-cooled condensers. Past experience indicated that operation of these controls was highly dependent on the chiller module configuration and its operating characteristics. Accordingly, it was concluded that evaluation of their operation during initial test operation was necessary to evaluate any further need for modifications.

### 3.1.4.3 Purge Control

Control elements external to the purge unit are provided in the chiller module. Solenoid valves are provided to select either the power loop or the cooling loop for purging and to isolate the loop not being purged. Manual needle valves are provided in the vapor line and liquid return line to adjust the purge flow rate.

### 3.1.5 Module Predicted Performance

With all elements of the chiller module defined, analyses were made to evaluate the module performance over the full range of module boundary conditions. To accomplish this, the UTRC Rankine Cycle Performance Prediction (RCPP) computer program was revised to model the performance characteristics of the modified components. All loss coefficients for pressure drops, heat losses, and mechanical work loss were modified to reflect values measured during tests conducted in the UTRC laboratory facility.

The results of these analyses are provided in Fig. 3-5. Cooling output (tons) and Coefficient of Performance (COP) are shown as a function of vaporizer water temperature, ambient temperature, and evaporator inlet water temperature. At the 18-ton design point, a COP of 0.58 is indicated with 287 F vaporizer water temperature, 95 F ambient air temperature, and 55 F evaporator inlet water temperature.

## 3.2 Solar Collector/Storage Subsystem Design and Selection

Solar collectors of several types from various manufacturers were compared in selecting collectors for the SOLERAS installation. A comparison of efficiencies of several designs are shown on Fig. 3-6. The superior performance of the parabolic trough type is clearly indicated. Consideration of cost and delivery of alternative collectors of this type as summarized in Table 3-6 resulted in selection of the Suntec collectors.

In order to select the most appropriate collector/storage system configuration, the effects of collector size and storage tank size on overall system performance were evaluated. This task was performed by means of an analytical simulation of the building cooling loads and the complete solar system installation including the solar collectors, tanks, UTRC chiller module, air handling system fan coils and auxiliaries. These calculations require the use of UTRC's Rankine Cycle Performance Prediction (RCPP) and modified TRNSYS computer programs. Both programs were modified to simulate the specific equipment and the Hamilton Test System (HTS) building selected for this program. A detailed load model was developed for the HTS building and verified by comparing calculated building temperatures (with operation of the existing electric A/C's) with approximated

# PREDICTED PERFORMANCE OF SOLAR CHILLER MODULE

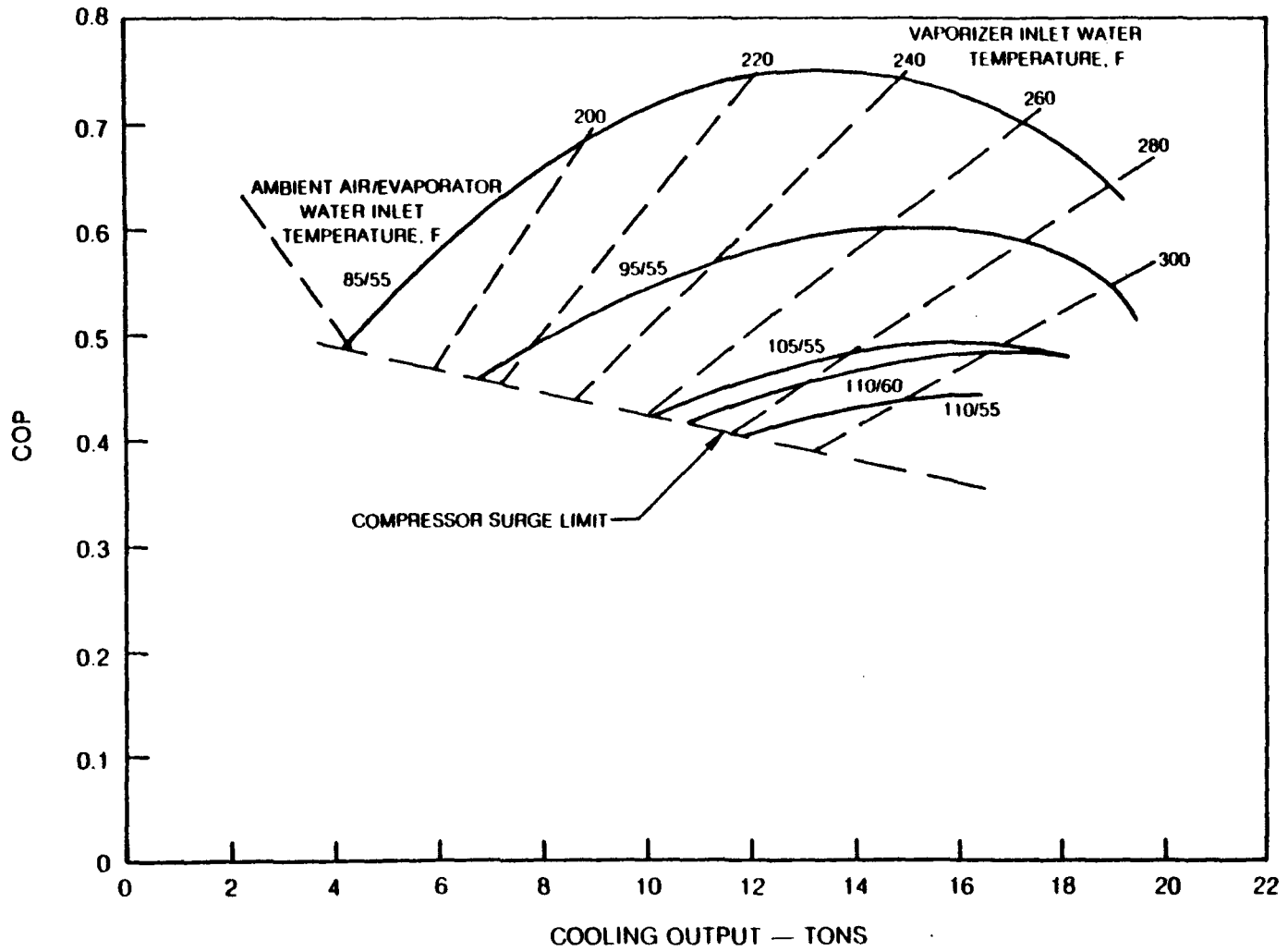

3-15

80-5-5-4

R82-955027-2

FIG. 3-5

### SOLAR COLLECTOR EFFICIENCY

|                                  | TYPE |
|----------------------------------|------|
| A - SUNTEC - MODEL SH 1655       | PT   |
| B - SOLAR KINETICS - MODEL T-700 | PT   |
| C - ACUREX - MODEL 3001          | PT   |
| D - ENERGY DESIGN - MODEL XE-300 | CPC  |

SOLAR INSOLATION = 300 BTU/FT<sup>2</sup>/HR

AMBIENT TEMPERATURE = 80 F

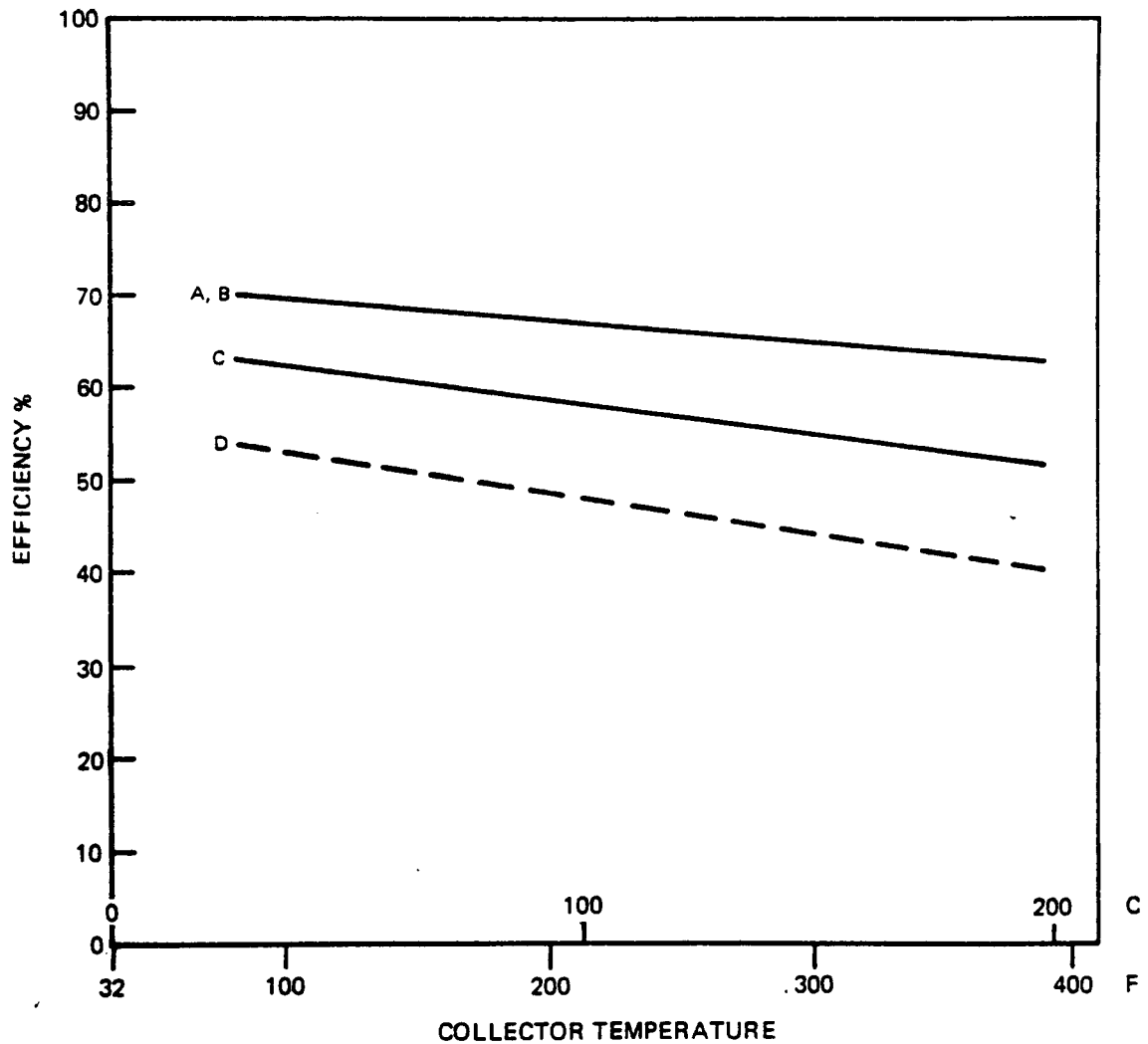

TABLE 3-6

## ALTERNATIVE PARABOLIC TROUGH COLLECTORS

| <u>Manufacturer</u> | <u>No. Rows</u> | <u>Net Area</u><br><u>ft<sup>2</sup></u> | <u>Cost</u><br><u>\$</u> | <u>\$/ft<sup>2</sup></u> | <u>Delivery</u> |
|---------------------|-----------------|------------------------------------------|--------------------------|--------------------------|-----------------|
| Suntec              | 2               | 1316                                     | 35,000                   | 26.6                     | 8-15-80         |
| Solar Kinetics      | 3               | 1649                                     | 52,500                   | 31.8                     | 8-15-80         |
| Acurex              | 3               | 1399                                     | 37,000                   | 26.5                     | 9-30-80         |

observations. For these efforts, the RCPP program was modified to include a detailed heat transfer and pressure drop model of the selected air-cooled condensers and the experimentally observed UTRC turbocompressor system component performance characteristics. The UTRC TRNSYS program was additionally modified to incorporate the performance characteristics of a wet and dry fan-coil. The simulation includes stratified hot and cold tanks, heat losses in all components and piping, thermal capacitance in all piping and the building and, of course, the storage tanks, and humidity capacitance in the conditioned space. These computer programs were used to assess the UTRC solar system performance as a function of collector type and area, as well as storage tank size.

Results of these analyses which are summarized in Table 3-7 provided the basis for selecting two rows of Suntec collectors, a 1500-gal hot storage tank and a 2000-gal cold storage tank. By using this combination of collector and tank sizes in conjunction with the UTRC chiller module, the output profile provided by the solar cooling system would well match the air conditioning load profile of the HST building being served. Although the backup electric air conditioning system would always be utilized part time, it was estimated the solar cooling system could provide 70 to 80 percent of the annual air conditioning needs.

### 3.3 Thermal Distribution Subsystem Design and Selection

Although the cold water storage tank is considered part of the thermal distribution subsystem, it was necessary to size it as part of the solar collector/hot tank selection process described above. Also, the air handling fan-coil was included in these analyses but it was merely assumed that its requirements could be satisfied by an available commercial unit. The evaluation process used to select the three air handling fan-coil units for this application are described in the following paragraphs.

#### 3.3.1 Air Handling Fan-Coils

The performance and size data for several air handling fan-coil models (nominal rated at 5 and 7.5 tons) made by Carrier, Magic Aire and McQuay were examined and intercompared. Many of the available models were excluded because they could not be fitted adjacent to the distribution ducts in the air space between the roof and the suspended ceiling. The design requirements are specified in Table 3-8. Table 3.9 contains a comparison of those units that satisfy both the size and the performance requirements.

Any of the 5-ton units listed in Table 3-9 is suitable for the present application. However, it was desirable to use the same make of fan-coil for both the 5-ton and the 7.5 ton units. A search of available product catalogues from Magic

TABLE 3-7

## SOLAR COOLING SYSTEM PERFORMANCE

|                                            |        |      |       |       |       |        |
|--------------------------------------------|--------|------|-------|-------|-------|--------|
| Operating period                           | July   | July | July  | July  | April | Annual |
| Collector rows                             | 1.5    | 2    | 2     | 3     | 2     | 2      |
| Tank size, hot/cold<br>10 <sup>3</sup> gal | 2.25/1 | 3/1  | 1.5/2 | 4.5/1 | 3/1   | 3/1    |
| Energy, ton-hrs                            |        |      |       |       |       |        |
| . Collected                                | 3460   | 4490 | 4409  | 6515  | 4104  | 40,100 |
| . Vented                                   | 10     | 60   | 307   | 385   | 1555  | 8,400  |
| . Delivered cooling                        |        |      |       |       |       |        |
| . Solar System                             | 1095   | 1985 | 2093  | 2720  | 908   | 13,403 |
| . Backup                                   | 1370   | 575  | 593   | 35    | 0     | 1,485  |
| Solar contribution, %                      | 44     | 77   | 78    | 98    | 100   | 90     |

TABLE 3-8

## AIR HANDLING FAN-COIL DESIGN REQUIREMENTS

|                                       |         |
|---------------------------------------|---------|
| Nominal Output, tons                  | 5.0/7.5 |
| Sensible heat factor                  | ~ 1.0   |
| Entering air DBT, F                   | 79      |
| Entering air WBT, F                   | 62      |
| Air flow, CFM/ton                     | 480     |
| Entering chilled water temperature, F | 50      |
| Duct pressure drop, in. wg            | 0.72    |
| Maximum allowable height, in.         | 32      |

TABLE 3-9

## AIR HANDLING FAN-COIL COMPARISON

| 5-Ton Units                  |         |         |              |          |
|------------------------------|---------|---------|--------------|----------|
| Manufacturer                 | Carrier | Carrier | Magic Aire   | McQuay   |
| Model                        | 42BHS   | 39B-606 | HWBC-71/2-UL | SCB 301A |
| No. of rows                  | 6       | 6       | 6            | 6        |
| Air pressure drop,<br>in. wg | 0.47    | 0.49    | 0.55         | 0.40     |
| Height, in.                  | 29      | 30.5    | 27           | < 30     |
| 7.5-Ton Units                |         |         |              |          |
| Manufacturer                 | Carrier | Carrier |              |          |
| Model                        | 42BH6   | 39B-606 |              |          |
| No. of rows                  | 6       | 8       |              |          |
| Air pressure drop, in. wg    | 0.49    | 1.25    |              |          |
| Height, in.                  | 29      | 30.5    |              |          |

Aire and McQuay did not reveal any fan-coil units that would be suitable for the 7.5-ton service, given the aforementioned height limitations. The selection process reduced to a choice between Carrier 42BH 5 & 6 units and 39B-060 units. The former models were chosen because of their lower air-side pressure drop. The detailed characteristics of these coils are given in Table 3-10.

### 3.4 Central Control System Design

A control system based on the use of a central controller is utilized to integrate the operations of the major subsystems and components of the solar cooling system and the backup air conditioners into a complete and automatic air conditioning system. The overall control system concept selected for the application is shown in schematic form in Fig. 3.7 and is based on simple on/off operation of the major subsystems. The criteria considered for the control system design and selection are: it should (1) be simple yet provide the flexibility needed to permit maximum solar contribution, (2) provide control which would not impair backup system operation when required and (3) utilize standard HVAC components.

#### 3.4.1 Control Strategy Selection

TRNSYS simulations were used to model alternative system control strategies and set points. For example, a simple room thermostat operated system, shut off nightly and on weekends, was compared with a similar strategy which allows weekend operation any time the hot storage tank is on the verge of venting. The latter strategy would provide cooling when the building is unoccupied in an attempt to use the building as a heat sink and reduce weekday cooling requirements. The results of this comparison indicated the weekend operation had no significant energy savings. However, weekend cold tank charging without fan-coil operation does produce a modest benefit. Weekend hot tank charging and evening chiller operation and cold tank charging also provides a modest benefit.

Alternative chiller module control strategies were evaluated in an effort to increase the annual performance. By raising the hot tank temperature required to start the chiller module (an operational permissive), while maintaining a low shutdown temperature setting (determined by the turbocompressor surge limit), the average chiller output is increased. Thus, the chiller operating time and auxiliary electric energy consumption are reduced.

#### 3.4.2 Hardware Selection

A Modicon microprocessor-based minicomputer controller was chosen to perform all required turn ON-OFF sequences as dictated by the control requirements of the solar cooling system. This unit was selected by UTRC (and funded by UTRC) as a test vehicle to assist in the final characterization of the overall cooling

TABLE 3-10  
 CHARACTERISTICS OF THE SELECTED AIR-HANDLING  
 FAN-COIL UNITS

| Model                                      | Nominal Rating, Tons       |                           |
|--------------------------------------------|----------------------------|---------------------------|
|                                            | <u>5</u><br>Carrier 42 BH5 | <u>7</u><br>Carrier 42BH6 |
| No. of tube rows                           | 6                          | 6                         |
| Air capacity, cfm                          | 2400                       | 3600                      |
| Face velocity, fpm                         | 320                        | 360                       |
| Face area, ft <sup>2</sup>                 | 7.5                        | 10.0                      |
| Design cooling capacity,<br>sensible Btu/h | 60,000                     | 90,000                    |
| Water temp. rise, F                        | 8                          | 8                         |
| Water flow rate, gpm                       | 15                         | 22.5                      |
| Air pressure drop, in. wg                  | 0.47                       | 0.49                      |
| Duct pressure drop, in. wg                 | 0.72                       | 0.72                      |
| Fan motor power, hp                        | 1.0                        | 1.5                       |
| Fan rpm                                    | 760                        | 860                       |
| Water pressure drop, in. wg                | 4.5                        | 10.0                      |
| Dimensions, L/W/H, in.                     | 44/48/29                   | 38.5/62/29                |
| Dealers Net Price, \$/ea                   | 1842                       | 2353                      |

### CONTROL SYSTEM CONCEPT

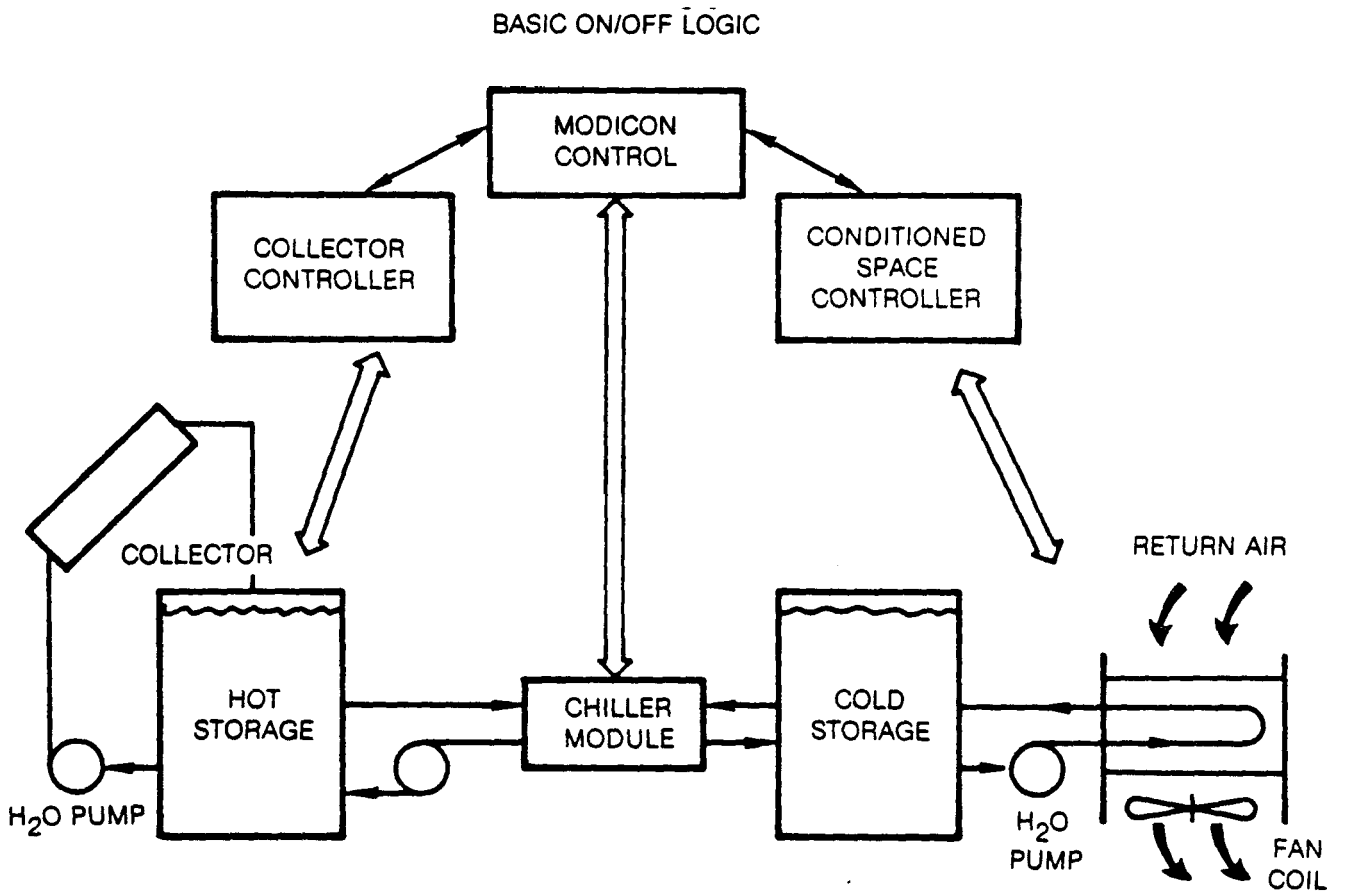

system. The Modicon controller provides the flexibility necessary to accommodate changing requirements which are to be expected during the evaluation phase of the solar cooling system.

The Modicon controller which serves to centralize the control functions provides easy manipulation of the control algorithms and assists in generating failure diagnostics when malfunctions occur. Controller logic provides for normal and emergency operation of the chiller, including definition of permissive operational sequences and time delays.

A Honeywell Model T872E with a sub-base Model Q672G thermostat was selected to provide room temperature control in each zone. The device contains a two-stage set point adjustable by means of a single lever control. A differential temperature of 2 F between stages is maintained throughout the entire temperature control range. This unit replaces the existing room thermostats during solar system operation. Signals from this thermostat are fed into the Modicon controller which turns the appropriate air-handling fan coil on and off in accordance with the temperature setting. For example a solar system air handling fan-coil goes on when the room temperature rises to 78 F and goes off when the room temperature drops back to 76 F. However, if the room temperature continues to rise to 80 F the fan-coil is shut down and the backup electric air conditioner is turned on and continues to run until the room temperature drops to 79 F. The control logic for the building conditioned space is depicted in Fig. 3-8.

### 3.5 Data Acquisition System

The solar system instrumentation requirements were defined and provided the basis for designing and selecting the data acquisition system (DAS). These designs and components were then integrated with the solar cooling system controls which uses instrumentation data via the DAS to perform control functions.

At least thirty four parameters would be measured and recorded during the Phase III testing. These data provide regular documentation of the system performance including, but not limited to, (a) integrated cooling output (b) stored solar thermal energy, (c) integrated values of input thermal energy collected and delivered to chiller module vaporizer (d) auxiliary energy consumption and (e) collector efficiency. These performance data are to be calculated with short term averaged parameters, integrated weekly and reported every quarter on a monthly basis. Instrumentation requirements and specifications are summarized in Tables 3-11 and 3-12.

### SOLERAS CONDITIONED SPACE LOGIC DIAGRAM

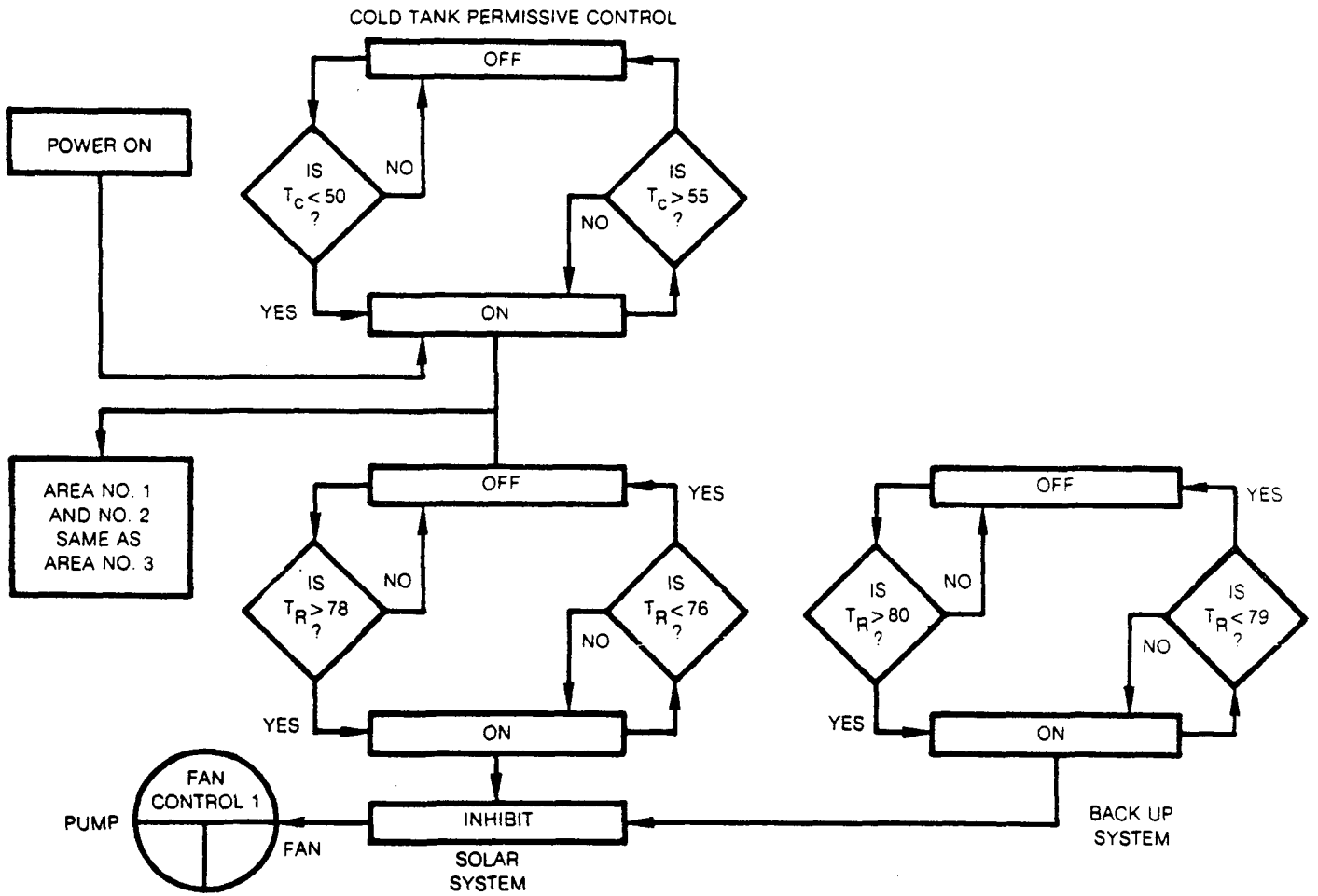

AREA NO. 3

TABLE 3-11

## INSTRUMENTATION REQUIREMENTS

Water Conditions

|                      | <u>Nominal</u>                                                       | <u>Maximum</u>                |
|----------------------|----------------------------------------------------------------------|-------------------------------|
| Solar Flow Loop      | $\dot{W} = 20 \text{ gpm}$<br>$\Delta T = 20 \text{ }^\circ\text{F}$ | 25 gpm<br>30 $^\circ\text{F}$ |
| Vaporizer Flow Loop  | $\dot{W} = 63 \text{ gpm}$<br>$\Delta T = 12 \text{ }^\circ\text{F}$ | 80 gpm<br>20 $^\circ\text{F}$ |
| Evaporator Flow Loop | $\dot{W} = 40 \text{ gpm}$<br>$\Delta T = 10 \text{ }^\circ\text{F}$ | 55 gpm<br>15 $^\circ\text{F}$ |
| Fan Coil Flow Loop   | $\dot{W} = 55 \text{ gpm}$<br>$\Delta T = 8 \text{ }^\circ\text{F}$  | 60 gpm<br>16 $^\circ\text{F}$ |

R-11 Conditions

| Chiller      |        | <u>Nominal</u>           | <u>Min.</u> | <u>Max.</u>          |
|--------------|--------|--------------------------|-------------|----------------------|
| Power Loop   | - V.G. | P = 235 psia             | 50          | 325 psia             |
|              | V.G.   | T = 275 $^\circ\text{F}$ | 150         | 310 $^\circ\text{F}$ |
|              | Cond.  | P = 25 psia              | 10          | 40 psia              |
|              | Turb.  | N = 35,000 rpm           |             | 50,000 rpm           |
| Cooling Loop | Evap.  | P = 7.0 psia             | 5           | 20 psia              |
|              | Evap.  | T = 40 $^\circ\text{F}$  | 25          | 75 psia              |
|              | Cond.  | P = 25 psia              | 10          | 40 psia              |
|              | Cond.  | T = 105 $^\circ\text{F}$ | 60          | 130 $^\circ\text{F}$ |

TABLE 3-11

## INSTRUMENTATION REQUIREMENTS (Continued)

General Conditions

|            |   |                                |
|------------|---|--------------------------------|
| $T_{amb}$  | = | 20 - 120 °F                    |
| $T_{room}$ | = | 50 - 100 °F                    |
| I          | = | 0 - 350 Btu/hr/ft <sup>2</sup> |
| t          | ≈ | 150 h/mo.                      |

Power Meters

|            |   |          |
|------------|---|----------|
| Solar kW   | ≈ | 15       |
| Solar kWh  | ≈ | 2000/mo. |
| Backup kW  | ≈ | 28       |
| Backup kWh | ≈ | 1000/mo. |

Storage Tanks

|      |       |   |              |
|------|-------|---|--------------|
| Hot  | $T_u$ | = | 180 - 330 °F |
|      | $T_l$ | = | 180 - 330 °F |
| Cold | $T_u$ | = | 30 - 75 °F   |
|      | $T_l$ | = | 30 - 75 °F   |

## PRELIMINARY INSTRUMENTATION SPECIFICATIONS

Signal Conditioning

Performed by DAS.

Power

Recording watt-hr meters such as Ohio Semitronics.

Speed

Magnetic pickup on turbocompressor shaft.

Digitec Counter Model 8151

Calibrated to 1 MHz  $\pm$  1 Hz

Readout:  $\pm$  1 count

Flow

Flow Technology Model PRI-3 Rate Indicator

Readout: engineering units plus analog voltage supplied to DAS

Accuracy: 0.05% of reading  $\pm$  1 count

Turbine Meters

Flow Technology: precision curves supplied for specific flow conditions

UTRC or Cox flowmeters: calibration curves supplied for specified flow conditions to within 0.25% full scale accuracy

Pressure

DC-DC transducers such as Kulite Series calibrated to within 1% accuracy.

Temperature

Copper/constantan T/C used for  $\Delta T$  measurements. Absolute temperatures to be measured with platinum winding RTD's and fed directly to DAS.

A brief evaluation of commercially available data acquisition devices (dataloggers) was conducted on the basis of the manufacturers reported features/capabilities. A comparison of the UTC-SOLERAS installation DAS requirements with the capabilities (such as number and type of inputs accepted, number of channels, scan rate, data scaling capability, alarms, and operator interfaces) of the available data loggers identified eight (8) candidate devices out of over eighty-five (85).

Of these eight (8) devices, two (2) were evaluated in detail and appeared to match the SOLERAS requirements without excess capacity. These are the Consolidated Controls Corp. 90 MCl and the Acurex Autodata Ten/5. Both units are of comparable cost. Based on detailed discussions with the manufacturers representatives and other users (within UTC) of this equipment, and assessment of the means and/or techniques utilized in achieving its operating features, the Autodata Ten/5 was selected for this application. Instantaneous and averaged data are stored on magnetic tape (cassette) for detailed analysis at UTRC.

A datalogger with the capabilities of the Autodata Ten/5 is needed to accommodate; (a) the large number of channels (over 30) to be monitored, (b) a wide variety of inputs (pulse, high and low level direct voltage analog, RTD, thermocouple, BCD) and provide (c) flexible scan rate and data averaging, (d) modular construction to allow customized capabilities without excessive cost, (e) data scaling by simple algebraic or logical functions, (f) switch points at preselected values, (g) on-off switching decisions based on chiller operating conditions, (h) paper tape data readout, (i) simple operator interfacing with conversational programming, (j) visual operator aids, (k) alarm and data identification messages and (l) easy interfacing with magnetic mass storage.

Specifications and capabilities of Autodata Ten/5 are summarized in Table 3-13 and its function operations are depicted in Fig. 3-9.

### 3.6 Performance Analyses

Analyses of the solar cooling system were conducted to predict its season performance and reliability and maintainability characteristics. These analyses and the results obtained are described and discussed briefly in the following paragraphs.

#### 3.6.1 Seasonal Performance

After having selected preliminary control system strategies and set points, TRNSYS simulation analyses were conducted to assess the potential seasonal performance of the solar cooling system in the HTS building. The results of these analyses are summarized in Tables 3-14 and 3-15. The number of hours each major subsystem is operated during each month and for the entire year (a typical meteorological year) is presented in Table 3-14. Also shown therein is the estimated electrical power consumption of each subsystem. In these

TABLE 3-13

## DATA ACQUISITION SYSTEM SPECIFICATIONS

Tentatively selected as the DAS is the Autodata Ten/5 which also has limited control capability.

Measurement Method: voltage-frequency converter  
 System Scanning Speed: up to 35 readings per second  
 Normal Mode Rejection: 70 dB standard at line frequency  
 Common Mode Rejection: 120 dB at 0-2 kHz (160 dB at 60 Hz)  
 Output Ranges: to  $\pm 10$  volts  
 Resolution: 5 microvolts on 50 mv range standard  
 Thermocouple Conformity: 0.1°C  
 Automatic Calibration: guarded 10.000 volt source used with IDVM  
 Automatic Zeroing System Accuracy (for voltage measurements):  
 $\pm 0.025\%$  of full scale standard  
 Channel Capacity: to 120  
 CRT Display  
 Printer: six lines per second, 21 column line length  
 Program Memory: battery protected RAM

Some of the built-in and optional features of the Autodata Ten/5 are:

Linear scaling of up to 20 functions in the form  $Y = MX + B$   
 Alarm and contact outputs  
 Direct conditioning and conversion of thermocouple and RTD inputs to readout  
 in engineering units  
 Optional expanded math package

### DATA ACQUISITION SYSTEM

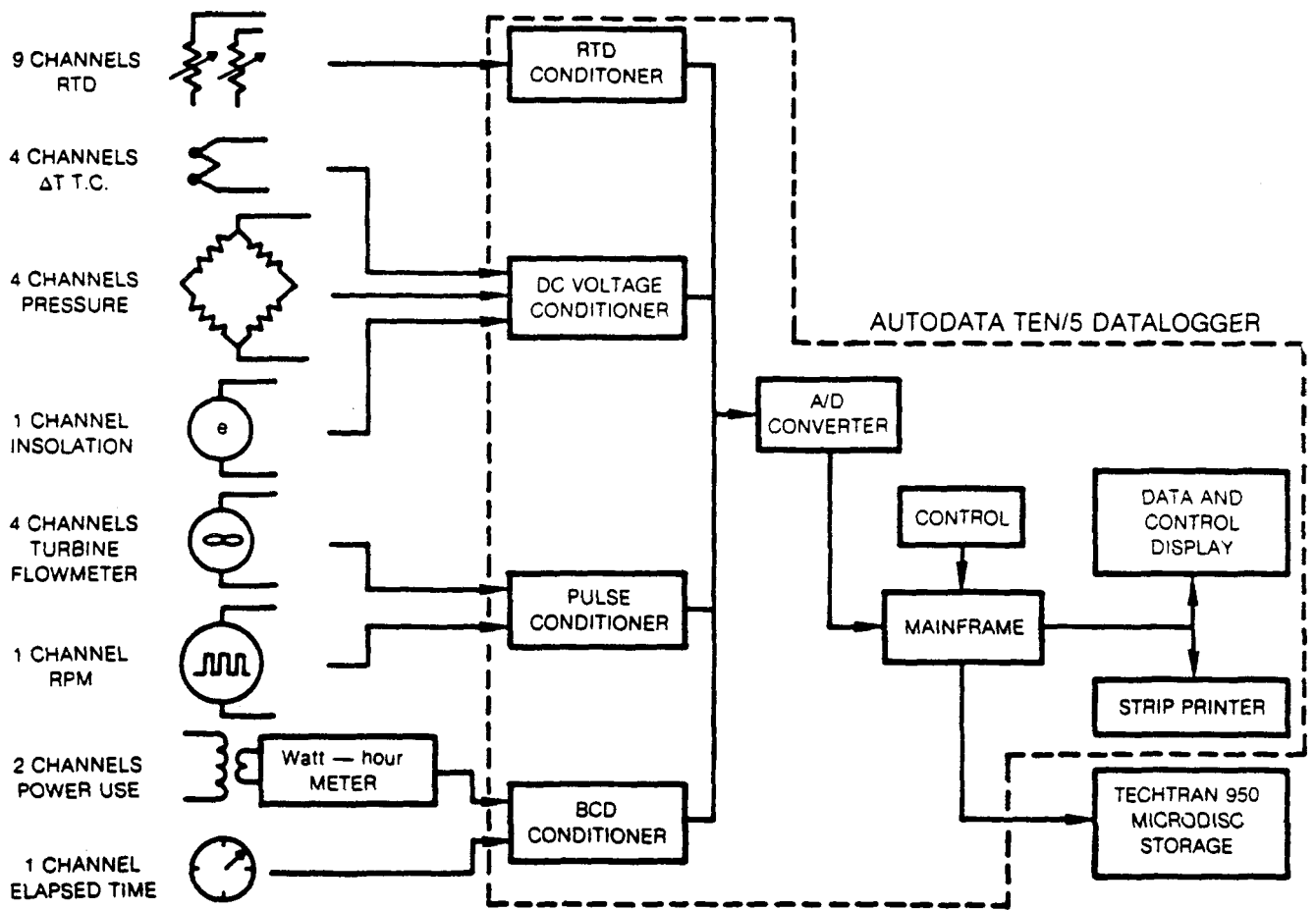

TABLE 3-14

## SUMMARY OF PREDICTED SYSTEM OPERATING TIME

| Month                               | Operating Time, Hours    |          |                |                         | O/U <sup>(3)</sup> |
|-------------------------------------|--------------------------|----------|----------------|-------------------------|--------------------|
|                                     | Collector <sup>(1)</sup> | Fan-Coil | Chiller Module | Backup                  |                    |
| Jan.                                | 323                      | 4.5      | 7.1            | 0                       | 0.032              |
| Feb.                                | 240                      | 5.8      | 7.9            | 0                       | 0.039              |
| Mar.                                | 296                      | 31.8     | 35.3           | 0                       | 0.153              |
| Apr.                                | 320                      | 46.3     | 50.6           | 0                       | 0.23               |
| May                                 | 397                      | 64.2     | 64.0           | 27.2                    | 0.305              |
| Jun                                 | 367                      | 104.8    | 94.1           | 51.7                    | 0.428              |
| Jul                                 | 329                      | 110.9    | 105.5          | 65.1                    | 0.480              |
| Aug.                                | 346                      | 106.3    | 102.7          | 62.2                    | 0.467              |
| Sept.                               | 317                      | 87.1     | 88.7           | 46.0                    | 0.403              |
| Oct.                                | 294                      | 52.0     | 67.2           | 20.1                    | 0.320              |
| Nov.                                | 238                      | 36.2     | 33.6           | 0                       | 0.153              |
| Dec.                                | 239                      | 11.7     | 14.4           | 0                       | 0.065              |
| Season:                             | 3614                     | 661.6    | 671.1          | 272.3                   |                    |
| Electrical<br>power Required,<br>kW | 0.30                     | 2.70     | 8.50           | Variable <sup>(2)</sup> |                    |

(1) Maximum possible, actual is approximately 2 to 3 times chiller operating hours

(2) Varies with ambient and room air temperatures, ~ 26.5 kW at 85 F ambient and 80 F room.

(3) O/U - On time to Up time ratio

TABLE 3-15

## SUMMARY OF PREDICTED SYSTEM PERFORMANCE

| Month   | Cooling Delivered<br>(ton-hr) |        | Electrical Consumption<br>(kW-hr) |        | Solar System         |                            |                             |
|---------|-------------------------------|--------|-----------------------------------|--------|----------------------|----------------------------|-----------------------------|
|         | Solar                         | Backup | Solar                             | Backup | (EER)<br>with<br>f/c | Btu/hr-W<br>without<br>f/c | Average<br>Output<br>(tons) |
| Jan     | 92                            | 0      | 83                                | 0      | 13.3                 | 15.0                       | 13                          |
| Feb     | 118                           | 0      | 155                               | 0      | 9.1                  | 9.9                        | 15                          |
| Mar     | 627                           | 0      | 475                               | 0      | 15.8                 | 18.3                       | 17.7                        |
| Apr     | 908                           | 0      | 651                               | 0      | 16.7                 | 19.5                       | 17.9                        |
| May     | 1136                          | 454    | 802                               | 816    | 17.0                 | 20.2                       | 17.7                        |
| Jun     | 1468                          | 828    | 1161                              | 1574   | 15.2                 | 18.5                       | 15.6                        |
| Jul     | 1620                          | 1085   | 1272                              | 1844   | 15.3                 | 18.5                       | 15.4                        |
| Aug     | 1493                          | 1005   | 1234                              | 1865   | 14.5                 | 17.5                       | 14.5                        |
| Sept    | 1263                          | 755    | 1057                              | 1354   | 14.3                 | 17.2                       | 14.2                        |
| Oct     | 850                           | 339    | 755                               | 586    | 13.2                 | 15.2                       | 12.6                        |
| Nov     | 625                           | 0      | 455                               | 0      | 16.5                 | 19.6                       | 18.6                        |
| Dec     | 222                           | 0      | 225                               | 0      | 11.8                 | 13.2                       | 15.4                        |
| Season: | 10,422                        | 4,466  | 8,345                             | 8,039  | 15.0                 | 17.8                       |                             |

$$\text{Percent Solar} = \frac{10,422}{10,422 + 4,466} = 70\%$$

f/c = Air handling fan-coil fan and circulating water pump

analyses, it was assumed that the electrical power consumption of the chiller module would be constant because none of the motor driven pumps or fans were modulated. However, subsequently (when actually constructed and installed) the control strategy for chiller operation was changed such that individual condenser fans would be turned off at various set points as the ambient air temperature drops to 85 F and below. Below 70 F one fan remains on as long as the chiller continues to run. As indicated in Table 3-14 the backup electric air conditioner would be needed part time but only during the four summer months (June thru September). The electric power consumption of the backup unit varies with ambient and room air temperatures and is approximately 26.5 kW at an ambient temperature of 85 F and a room temperature of 80 F.

The cooling system performance data presented in Table 3-15 itemizes the cooling (ton-hr) delivered by and electrical consumption (kW-hr) of the solar subsystems and the backup electric units based on the operating data presented in Table 3-14. Also included in Table 3-15 are the electric energy efficiency ratios (EER's) predicted for the solar subsystem (with and without the fan coil contribution). On an annual basis the solar subsystem would provide as much as 70 percent of the building air conditioning needs. This is a conservative assessment of the system performance and represents a realistic goal. The potential average EER of the solar cooling system is predicted to be 17.8 Btu/hr-W without the f/c contribution. This compares to typical values of 6.5 to 7.5 for the electric air conditioning chillers. Even an advanced electric air conditioner (chiller) would have an EER of only 8.5 to 10.5. Thus, the installation of the solar cooling system would result in a substantial savings in electrical energy.

Although the TRNSYS simulation program is a powerful analytical tool, it is based on several items operating in an exact prescribed manner. In actual practice, for example, the chiller will not always be available for use when needed. Therefore, the calculated value of solar contribution can be as high as 90%; however, a more realistic value is nearer 70 percent as shown in Fig. 3-15.

### 3.6.2 Reliability and Maintainability

Reliability and maintainability (R&M) of the solar cooling system as well as its capital cost and energy efficiency are important characteristics since they will greatly affect its rate of entry into the commercial sector and hence its commercialization potential. These factors, therefore, should be considered in the early design and development stage of such a commercial product. Due in part to insufficient component data and experience, formal R&M analyses were not conducted in Phase I to impact the preliminary design and selection of components for the UTC solar cooling system to be field tested. However, analyses were conducted to establish the methodologies to be used in such an assessment. For convenience purposes, the description of the R&M assessment as it relates to the UTC cooling system to be field tested is reported as part of the Phase II activities in Section 4. A more detailed description is presented in Appendix C of Ref. 4, including the analysis as it relates to a future developed commercial production unit.

#### 4.0 DETAILED DESIGN CONSTRUCTION AND INSTALLATION

This section describes the detailed design, construction and installation features of the UTC solar cooling system at the test site. Included is a brief description of the reliability and maintainability analysis of the system to be field tested.

##### 4.1 System Installation Design and Construction

Detailed design of the solar system installation (plumbing, electrical, mechanicals and layouts) was subcontracted to Lowry-Sorenson-Wilcoxson Engineers, Inc. of Phoenix, Arizona. Collector support structure architectural and structural design services were contracted to Gosnell Developers of Phoenix, Arizona. These subcontracted services included preparation of plans, specifications and general conditions for construction/installation of the entire solar cooling system.

A local installation contractor, J. B. Rodgers Mechanical Contractors, was employed to provide and install electric power services, all water piping, instrumentation wiring, various control relays; as well as, install the chiller module, indoor fan/coil units, storage buffer and expansion tanks. In addition, the contractor constructed the collector support structure and equipment room and, assembled and installed the solar collectors. Construction began the first week of November, 1980 and the installation was completed in late February, 1981. Photographs of the completed system are presented in Figs. 4-0 and 4-1.

As shown in Fig. 4-1, the solar collectors are mounted atop a carport specially designed and constructed for this project. The chiller module (excluding the condensers) is located in an enclosed equipment at the north end of the carport. Air cooled condensers are mounted on the roof between the two rows of collectors (not visible in Fig. 4-1). The building to be air conditioned is to the north of the carport.

##### 4.1.1 Solar Collectors

The design of the solar collectors is embodied in the specifications and drawings furnished by the manufacturer, Suntec Corporation. The collector design and operation are described briefly in the following paragraphs. Detailed collector specification as provided by Suntec in their proposal are contained in Appendix B (Ref. 4). Engineering drawings of the collector and its installation are not included in this document but are available. Much of the detailed information is included in documents prepared for the design reviews held for this project. Operational details, in particular, are included in the Operating and Maintenance

# UTC SOLAR COOLING SYSTEM INSTALLATION



R82-955027-2

FIG. 4-0

4-2a

82-5-94-9

UTC SOLERAS SOLAR COOLING INSTALLATION  
PHOENIX, AZ

R82-955027-2

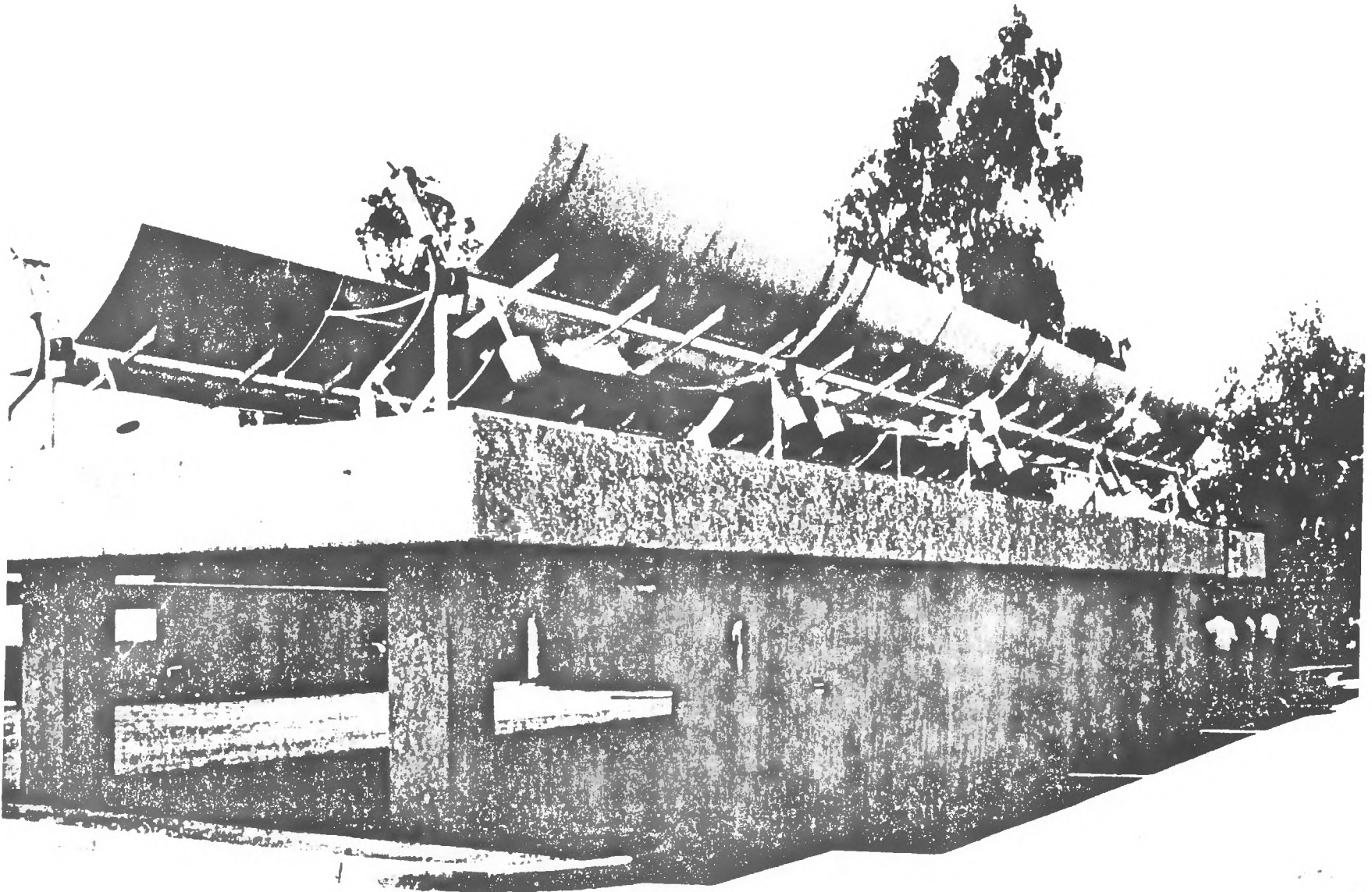

4-2b

FIG. 4-1

Manual (UTRC Report R81-955023-1). The solar collector type installed is a Suntec Model 5H-1655, single-axis tracking parabolic trough. The collector system consists of: (1) collector modules and (2) system common equipment. Two modules are utilized and each includes an 80-ft long collector panel and a (local) control system. The local control system not only causes the collector to track the daily movement of the sun but also includes a number of other operational and safety provisions including over-temperature protection.

The common system equipment consists of a microprocessor-based master control system and a battery power pack. A field-mounted photocell, the sun sensor, signals the master controller that sufficient solar intensity is available for operation. With this signal and a demand for heat, the master controller actuates the circulation pump. A ready signal showing that the pump is operating is then returned to the master controller which in turn authorizes the local controller to drive the collectors upwards from the stowed (inverted) position. The collectors track the sun and collect energy via water flowing through the absorber (receiver) tubing as long as the common sun sensor indicates sufficient solar intensity (insolation) is available.

#### 4.1.2 Chiller Module

The chiller module is a split system consisting of a pallet mounted equipment package and two remote air-cooled condenser units. The condensers were installed in tandem on the carport roof between the two rows of collectors as shown in Fig. 4-2. The chiller package was installed in the mechanical equipment room (see Fig. 4-3) which also houses the hot and cold expansion tanks, the solar master and central controllers and the data acquisition system. A plan view of the mechanical equipment room layout is presented in Fig. 4-4.

#### 4.1.3 Thermal Distribution System

Solar air conditioning of the HTS building was achieved by connecting three self contained fan-coil units into the existing duct work as shown in Fig. 4-5. Each fan coil assembly is equipped with its own pump which draws chilled water from a 2000-gal cold storage tank when there is a demand for cooling. The specifications for the fan coils and the circulating pumps are presented in Fig. 4-6. The cold water storage tank was insulated and buried in tandem with the hot tank (see Fig. 4-7) along-side the carport. Access to the tank connections (on the top of the tank) is maintained by means of a hatch covered well.

#### 4.1.4 Solar System Piping

The piping schematic drawing for the complete solar cooling system (as built) is presented in Fig. 4-8. The hot water and cold water piping and the refrigerant piping between the chiller pallet and the remotely located air-cooled condensers

# AIR COOLED CONDENSER INSTALLATION

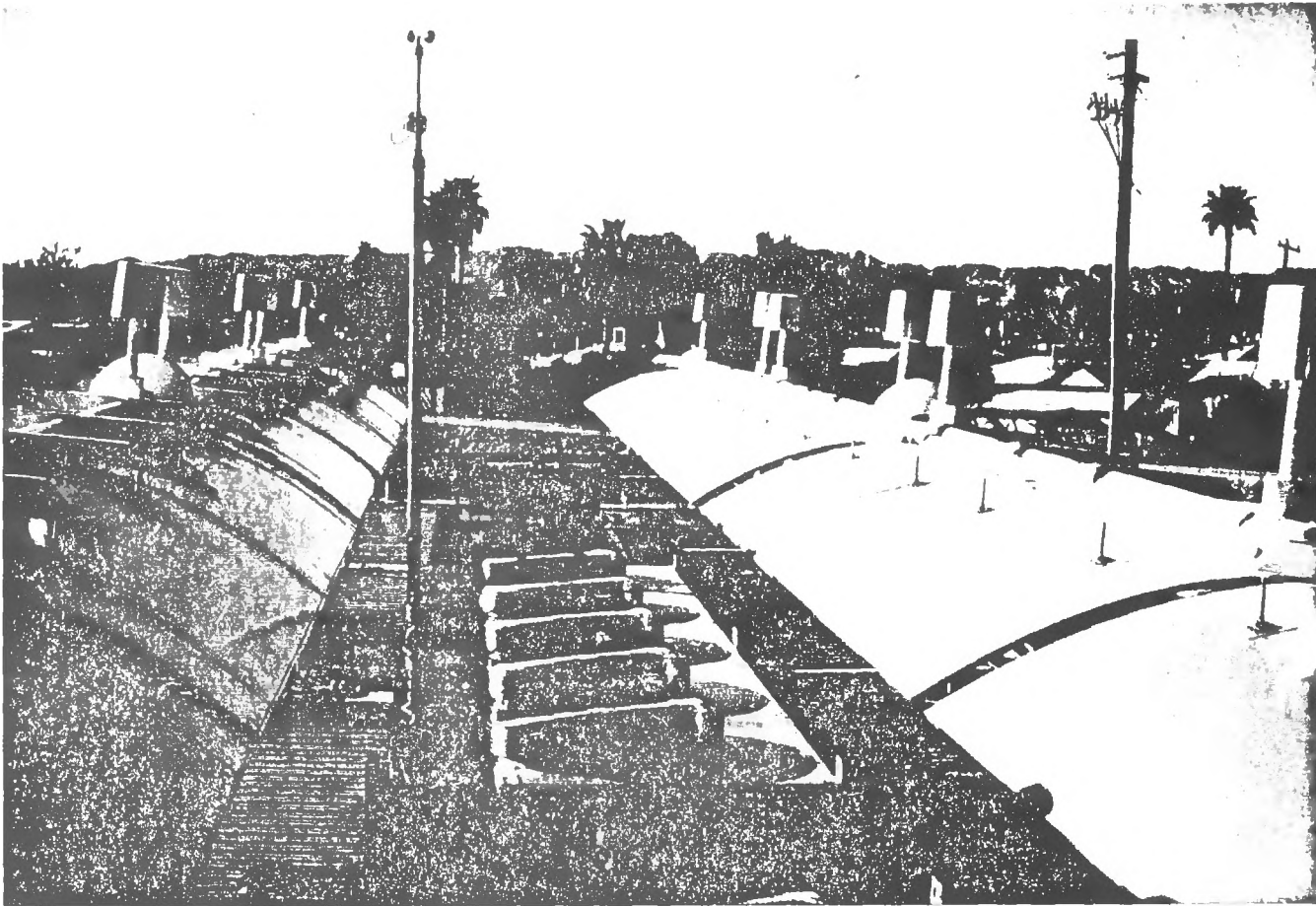
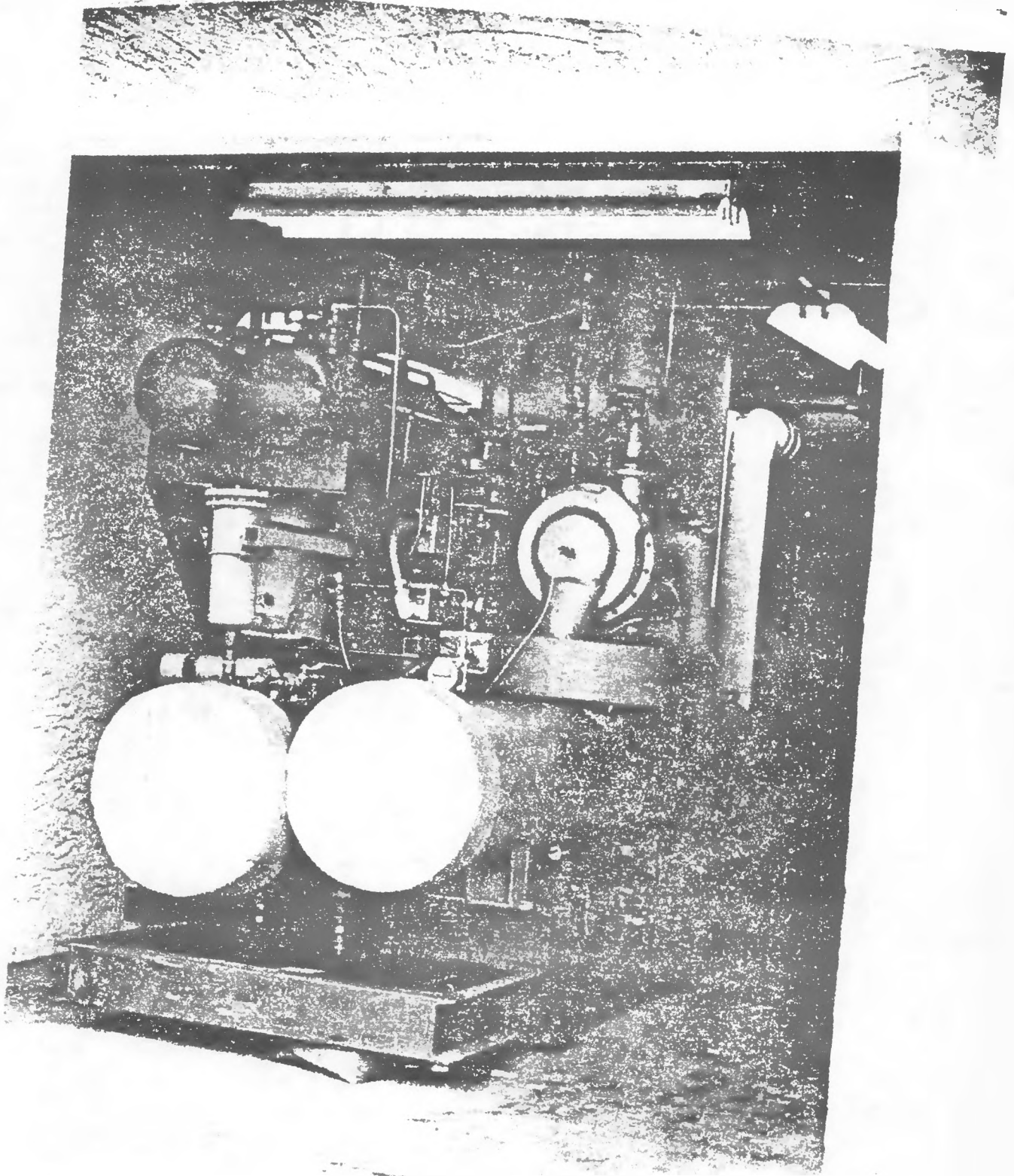

FIG. 4-2

CHILLER PACKAGE/EQUIPMENT ROOM

FIG. 4-3



### MECHANICAL EQUIPMENT ROOM LAYOUT

PLAN VIEW

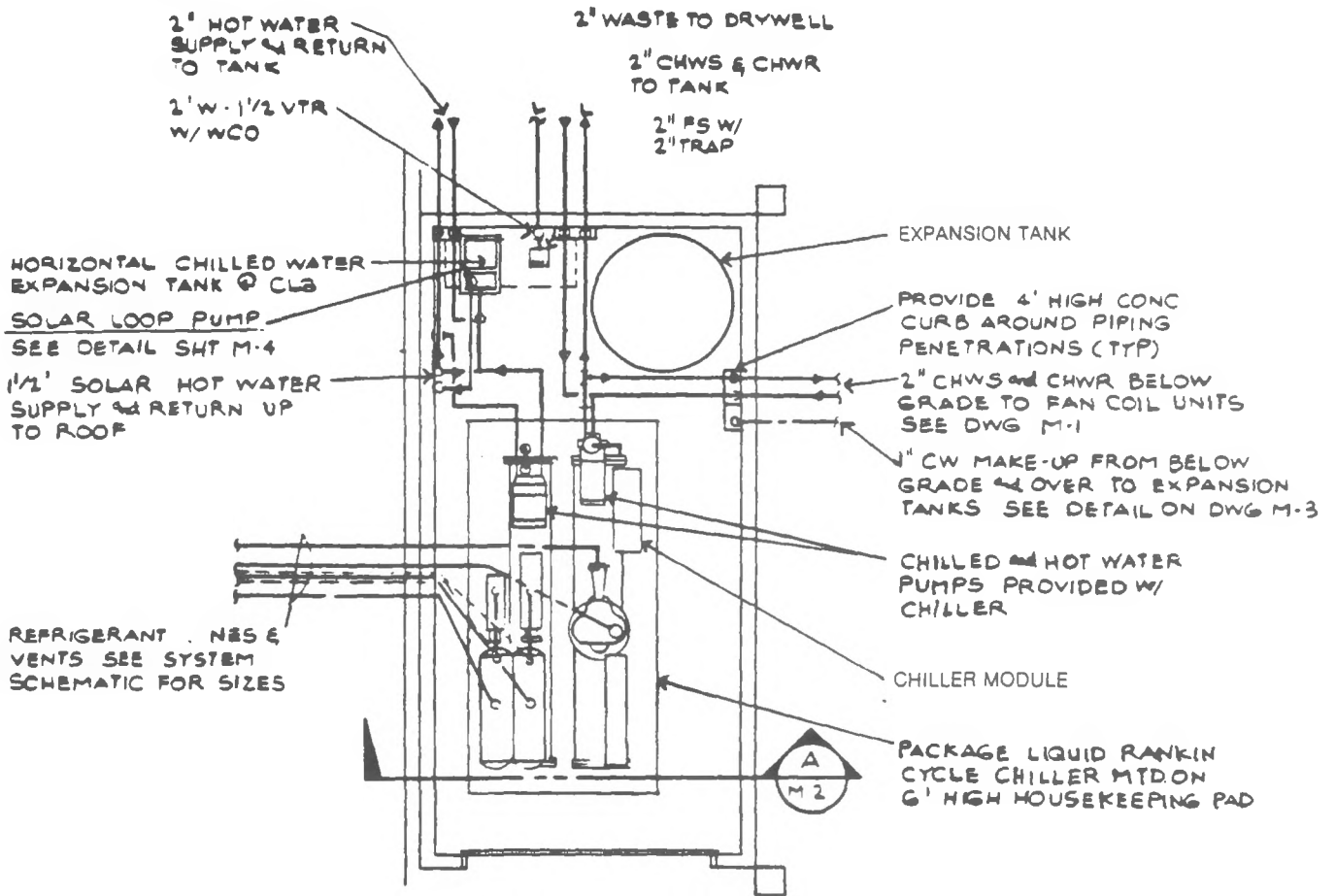

### MECHANICAL ROOM PLAN

SCALE 1/4" = 1'-0"

NOTE

FOR ALL PIPING SIZES & VALVING IN THIS AREA SEE PIPING SCHEMATIC THIS SHT



# SOLAR COOLING SYSTEM INSTALLATION

## FAN-COIL AND DUCTWORK LAYOUT

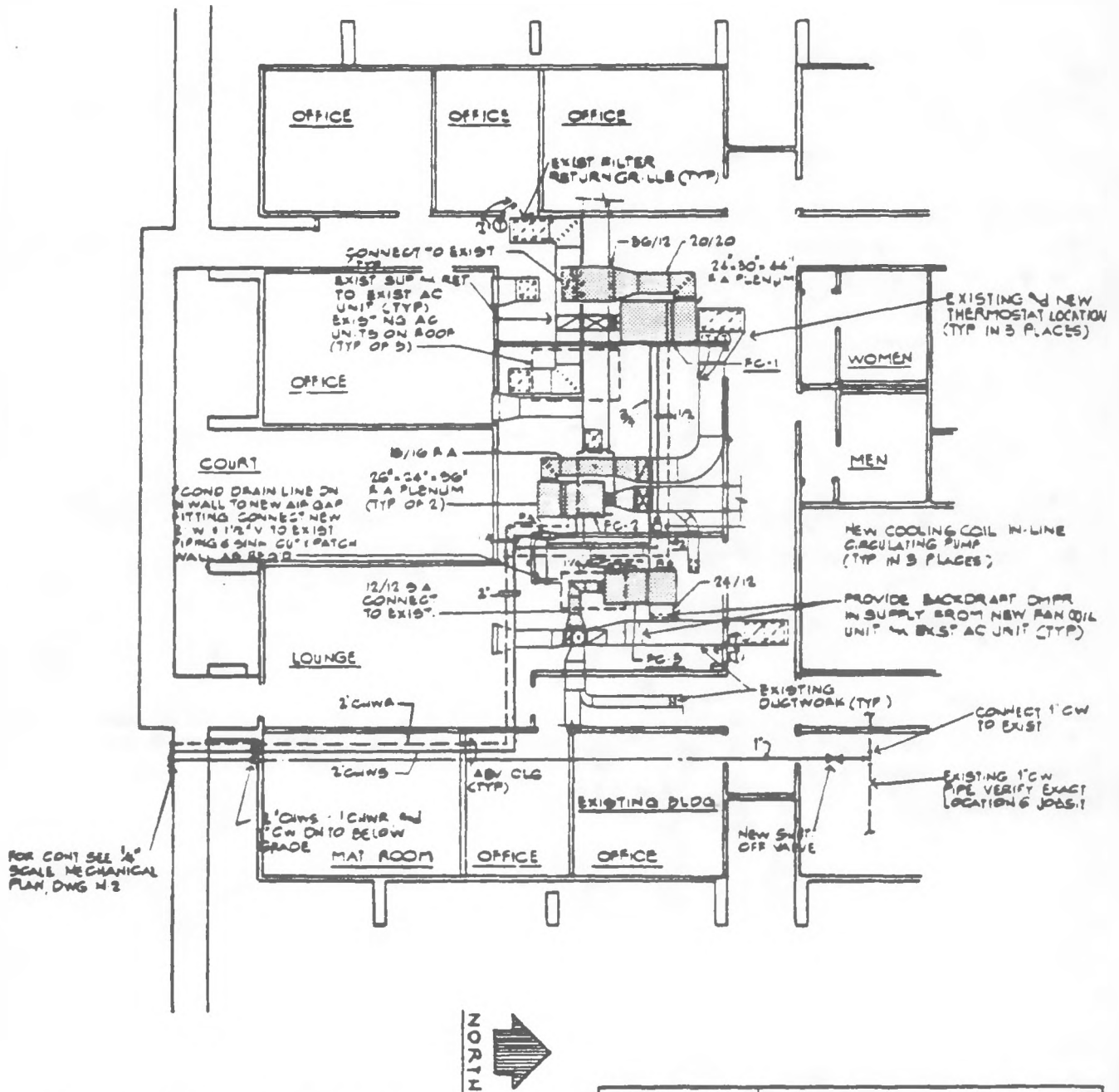

| FAN COIL UNIT SCHEDULE (NOMINAL) |         |        |          |                      |     |          |         |           |         |                           |                  |            |              |      |                      |                      |      |         |            |
|----------------------------------|---------|--------|----------|----------------------|-----|----------|---------|-----------|---------|---------------------------|------------------|------------|--------------|------|----------------------|----------------------|------|---------|------------|
| (FURNISHED BY UTRC)              |         |        |          |                      |     |          |         |           |         |                           |                  |            |              |      |                      |                      |      |         |            |
| MARK                             | MFR     | MODEL  | FAN DATA |                      |     |          |         |           |         | COIL DATA (CHILLED WATER) |                  |            |              |      |                      |                      |      | REMARKS |            |
|                                  |         |        | CFM      | SP IN INCHES (TOTAL) | BHP | MOTOR HP | FAN RPM | MOTOR RPM | V-φ-HZ  | TOTAL COOL MBTUH          | SENS. COOL MBTUH | AMB AIR °F | ENT AIR °FDB | °FWB | ENT H <sub>2</sub> O | LVG H <sub>2</sub> O | GPM  |         | PD IN FT   |
| FC-1                             | CARRIER | 42BH-6 | 3400     | 13                   | -   | 1/2      | 935     | 1750      | 208-360 | 92                        | 76               | 110        | 78           | 63.5 | 50°                  | 60°                  | 18.4 | 10      | G ROW COIL |
| FC-2                             |         | 42BH-5 | 2400     | 13                   | -   | 1        | 790     | 1750      | 208-360 | 68                        | 56               | 110        | 78           | 63.5 | 50°                  | 60°                  | 13.6 | 4.0     | "          |
| FC-3                             | ↓       | 42BH-5 | 2400     | 13                   | -   | 1        | 790     | 1750      | 208-360 | 68                        | 56               | 110        | 78           | 63.5 | 50°                  | 60°                  | 13.6 | 4.0     | "          |

CHILLER PACKAGE

PACKAGE LIQUID RANKIN CHILLER SHALL BE PREASSEMBLED AS A PACKAGE BY U.T.R.C. COMPLETE W/ CHILLED WATER & HOT WATER PUMPS. CONTRACTOR SHALL INSTALL CHILLER AS PER U.T.R.C. RECOMMENDATIONS & CONNECT ALL PIPING AS PER FLOW DIAGRAM THIS SHEET

CONDENSING UNITS (2)

POWER LOOP & COOLING LOOP CONDENSING UNITS SHALL BE FURNISHED BY U.T.R.C. & INSTALLED BY THE CONTRACTOR. U.T.R.C. SHALL FURNISH REFRIGERANT PIPING FROM CONDENSING UNIT TO CHILLER & CONTRACTOR SHALL FIELD MODIFY AS REQ'D. MFR SHALL BE "LARKIN"

SOLAR COLLECTORS

SOLAR COLLECTORS SHALL BE PROVIDED BY U.T.R.C. & ASSEMBLED & INSTALLED BY CONTRACTOR. CONTRACTOR SHALL PIPE & ASSEMBLE AS PER PLANS & DETAILS OF THESE DWG'S COLLECTORS ARE MFR. BY SUNTEC

## PUMP SCHEDULE

| MARK | MFR   | MODEL     | DESIGN POINT |      |     |       | 2 <sup>ND</sup> POINT |      |     |       | MOTOR |      |       |       | REMARKS                     |                 |
|------|-------|-----------|--------------|------|-----|-------|-----------------------|------|-----|-------|-------|------|-------|-------|-----------------------------|-----------------|
|      |       |           | GPM          | HEAD | BHP | EFF % | GPM                   | HEAD | BHP | EFF % | HP    | RPM  | VOLTS | CYCLE |                             | PHASE           |
|      |       |           |              |      |     |       |                       |      |     |       |       |      |       |       |                             |                 |
| P-1  | B & G | 1510      | 20 MAX       | 28   | -   | 42.5  | 40                    | 23   | -   | 46.5  | 1/2   | 1750 | 120   | 1     | 60                          | SOLAR LOOP PUMP |
| P-2  |       | SERIES 60 | 21.2         | 24   | -   | 37    | -                     | -    | -   | 1/2   | 1750  | 120  | 1     | 60    | FANCOIL UNIT 1 CIRCUIT PUMP |                 |
| P-3  |       | "         | 13.6         | 28   | -   | 30.0  | -                     | -    | -   | 1/8   | 1750  | 120  | 1     | 60    | " " " 2 "                   |                 |
| P-4  | ↓     | "         | 13.6         | 28   | -   | 30.0  | -                     | -    | -   | 1/8   | 1750  | 120  | 1     | 60    | " " " 3 "                   |                 |

### HOT AND COLD STORAGE TANK INSTALLATION

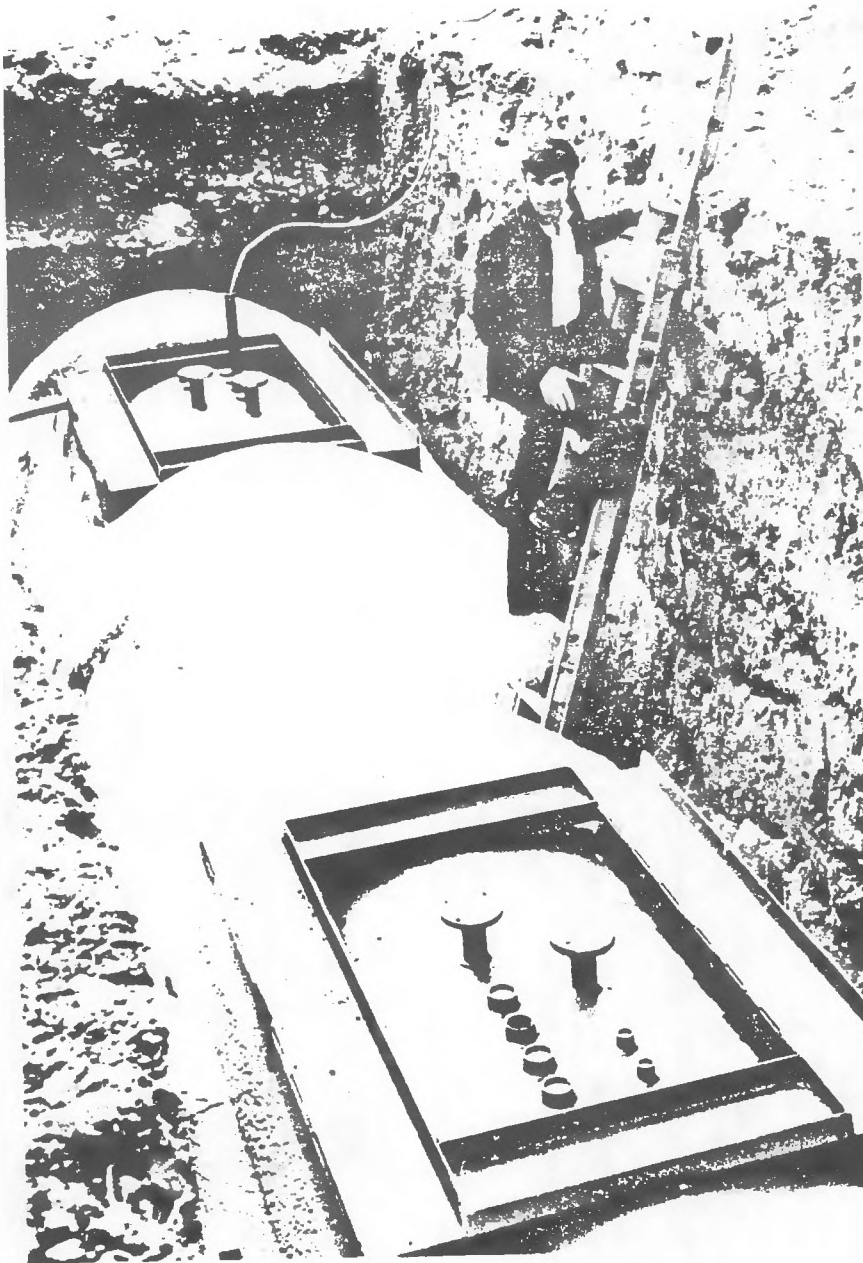

### SOLAR SYSTEM PIPING SCHEMATIC

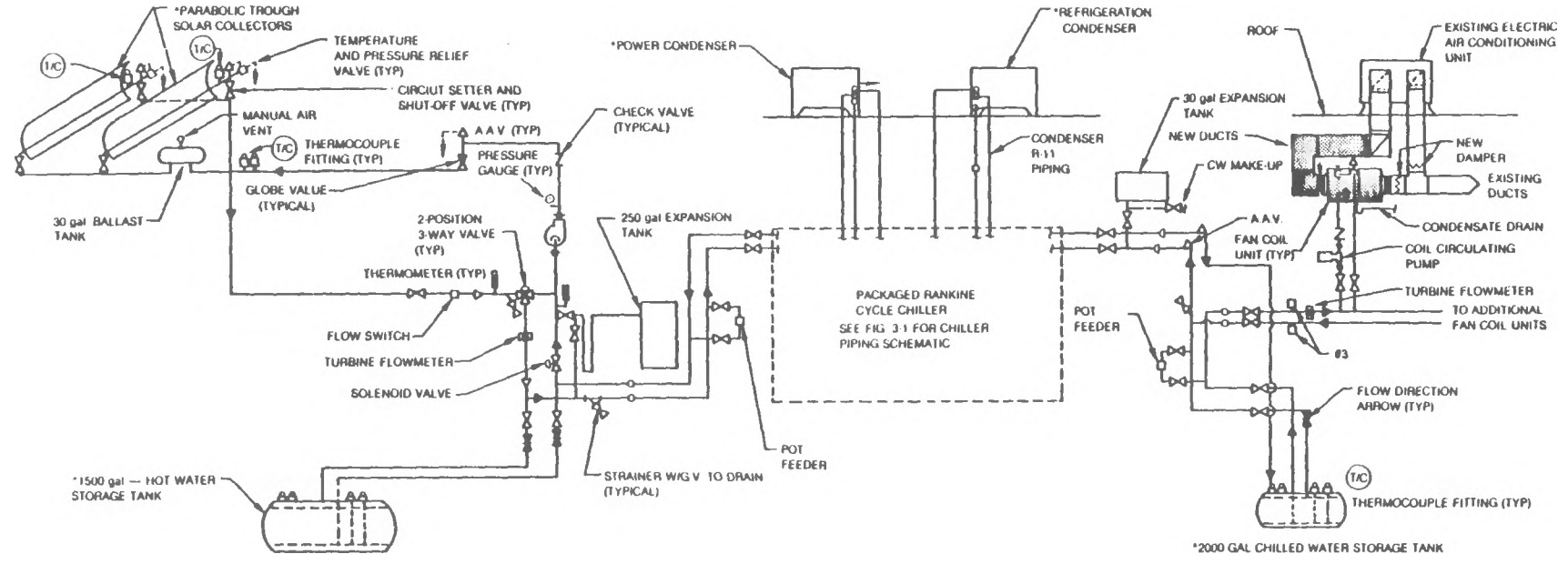

4-10

82-5-94-24

FIG. 4-8

which were installed onsite are depicted. The hot water loop between the solar collectors and the hot tank includes a 3-way valve which is controlled to open when the temperature of the water from the collectors is 10 F greater than the tank temperature. The refrigerant piping includes vapor lines which transport hot gases from the exhausts of the turbine and compressor, liquid lines which return condensate to the receivers and vapor vent lines also connected to the receivers.

The cold water piping is arranged such that each fan coil water pump independently, or in combination, withdraws chilled water from the bottom of the cold tank where the water is the coldest. When the chiller and fan coil(s) are operating simultaneously, the water from the fan coil is directed through the evaporator by the evaporator water pump and cooled before being returned to the cold tank. The desired distribution of chilled water through each fan coil is achieved by properly sizing each pump and by the use of check valves in each circuit to prevent backflow through fan coils not in use.

#### 4.1.5 Site Instrumentation and Data Acquisition

In order to control and monitor the operation of the UTC solar air conditioning system, a total of 35 temperature, pressure and frequency sensors were installed. An instrumentation list is presented in Table 4-1 and the sensor locations are depicted in Fig. 4-9. Output signals from the sensors are processed in the Autodata Ten/5 data acquisition system (DAS) and recorded in engineering units. Selected channel online digital readouts are displayed on the front face as shown in Fig. 4-10. Selected processed signals from the datalogger are also sent to the Modicon controller and utilized to actuate normal startup, run, shutdown and safety control functions.

In addition to the outputs measured by the 35 sensors (Table 4-1), several other parameters are monitored and recorded to document the performance of the solar cooling system. These include:

- . CON - Chiller on
- . SUP - System Up (Able to Run)
- . CODE - Shutdown Code

Since the DAS is equipped with a clock, it can perform functions that are time dependent. By scanning the output from selected instrumentation sensors each minute, the DAS can determine and record the amount of time the chiller is on (CON) and the amount of time it is up and available to run (lacking only a demand signal to cool down the cold tank). Under normal conditions (i.e., unattended operation), the solar cooling system output (i.e., the sensor output signals) are scanned every minute and recorded at the end of each 15-minute period. Selected data from the one-minute scans are time averaged over a 15-minute period and used

TABLE 4-1

## INSTRUMENTATION SENSORS AND DAS READOUT LOCATIONS

| <u>Channel</u> | <u>Symbol</u> | <u>Description</u>                    | <u>Units</u>           |
|----------------|---------------|---------------------------------------|------------------------|
| 19             | PEX           | Water Pressure Expansion Tank         | psia                   |
| 25             | PFVG          | Freon Pressure Vapor Generator        | psia                   |
| 26             | PFPC          | Freon Pressure Power Condenser        | psia                   |
| 27             | PFCC          | Freon Pressure Cooling Condenser      | psia                   |
| 28             | PFEV          | Freon Pressure Evaporator             | psia                   |
| 29             | IDIR          | Direct Solar Insolation               | Btu/hr ft <sup>2</sup> |
| 50             | TAMB          | Ambient Temperature                   | °F                     |
| 51             | TRMI          | Room Temperature 1                    | °F                     |
| 52             | TWCL          | Water Temp. Collector Flowmeter       | °F                     |
| 53             | THS1          | Temp. Hot Storage Top                 | °F                     |
| 54             | THS2          | Temp. Hot Storage Top Mid             | °F                     |
| 55             | THS3          | Temp. Hot Storage Bot Mid             | °F                     |
| 56             | THS4          | Temp. Hot Storage Bottom              | °F                     |
| 57             | TWVG          | Water Temp. Vapor Generator Flowmeter | °F                     |
| 58             | TFVG          | Freon Temp. Vapor Generator           | °F                     |
| 59             | TFCC          | Freon Temp. Cooling Condenser         | °F                     |
| 64             | RPM           | Turbine Speed                         | rpm                    |
| 69             | DTC1          | ΔT East Collector                     | °F                     |
| 73             | DTC2          | ΔT West Collector                     | °F                     |
| 75             | GWCL          | Water Flow Rate Collectors            | gpm                    |
| 86             | DTVG          | ΔT Water to Vapor Generator           | °F                     |
| 88             | GWVG          | Water Flow Rate Vapor Generator       | gpm                    |

TABLE 4-1

## INSTRUMENTATION SENSORS AND DAS READOUT LOCATIONS (Cont'd)

| <u>Channel</u> | <u>Symbol</u> | <u>Description</u>                    | <u>Units</u> |
|----------------|---------------|---------------------------------------|--------------|
| 96             | DTEV          | $\Delta$ T Water Evaporator Flowmeter | $^{\circ}$ F |
| 98             | GWEV          | Water Flow Rate Evaporator            | gpm          |
| 106            | DTFC          | $\Delta$ T Water Fan Coil Flowmeter   | $^{\circ}$ F |
| 108            | GWFC          | Water Flow Rate Fan Coil              | gpm          |
| 140            | TFEV          | Freon Temp. Evaporator                | $^{\circ}$ F |
| 141            | TWEV          | Water Temp. Evaporator Flowmeter      | $^{\circ}$ F |
| 142            | TCS1          | Temp. Cold Storage Top                | $^{\circ}$ F |
| 143            | TCS2          | Temp. Cold Storage Top Mid            | $^{\circ}$ F |
| 144            | TCS3          | Temp. Cold Storage Bot Mid            | $^{\circ}$ F |
| 145            | TCS4          | Temp. Cold Storage Bottom             | $^{\circ}$ F |
| 146            | TWFC          | Water Temp. Fan Coil Flowmeter        | $^{\circ}$ F |
| 147            | TTS1          | Turbine Seal Temperature 1            | $^{\circ}$ F |
| 148            | TTS6          | Turbine Seal Temperature 6            | $^{\circ}$ F |

### SOLAR COOLING SYSTEM INSTRUMENTATION SENSOR LOCATION

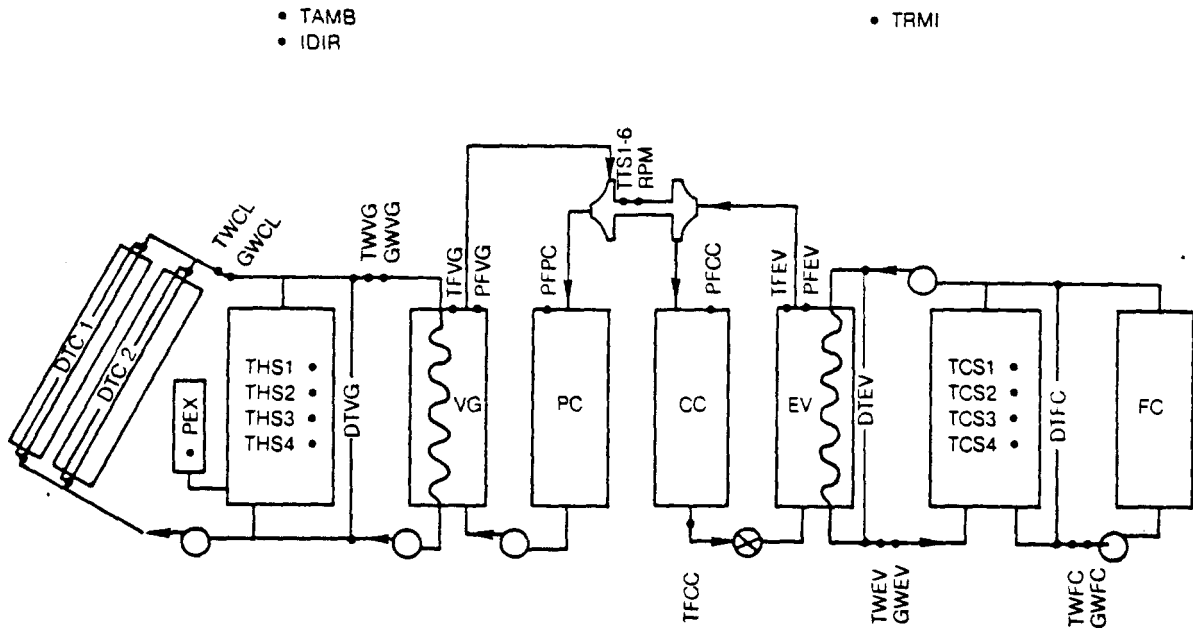

ACUREX Corporation

006 194 DEG F

Autodata Ten/5

3-15

|          |   |   |   |   |   |       |   |   |
|----------|---|---|---|---|---|-------|---|---|
| SCAN     | • | A | B | C | D | 7     | 8 | 9 |
| CHANNEL  | • | E | F | G | H | 4     | 5 | 6 |
| E/U CONV | • | I | J | K | L | 1     | 2 | 3 |
| FORMAT   | • | M | N | O | P | SPACE | 0 | . |
| TIME     | • | Q | R | S | T |       |   |   |
| SUMMARY  | • |   |   |   |   |       |   |   |
| OPTIONS  | • |   |   |   |   |       |   |   |

```

135 00000
136 0 00000 000
137 0 00000 000
138 0 00000 000
139 0 00000 000
140 0 00000 000
141 0 00000 000
142 0 00000 000
143 0 00000 000
144 0 00000 000
145 0 00000 000
146 0 00000 000
147 0 00000 000
148 0 00000 000
149 0 00000 000
150 0 00000 000
151 0 00000 000
152 0 00000 000
153 0 00000 000
154 0 00000 000
155 0 00000 000
156 0 00000 000
157 0 00000 000
158 0 00000 000
159 0 00000 000
160 0 00000 000
161 0 00000 000
162 0 00000 000
163 0 00000 000
164 0 00000 000
165 0 00000 000
166 0 00000 000
167 0 00000 000
168 0 00000 000
169 0 00000 000
170 0 00000 000
171 0 00000 000
172 0 00000 000
173 0 00000 000
174 0 00000 000
175 0 00000 000
176 0 00000 000
177 0 00000 000
178 0 00000 000
179 0 00000 000
180 0 00000 000
181 0 00000 000
182 0 00000 000
183 0 00000 000
184 0 00000 000
185 0 00000 000
186 0 00000 000
187 0 00000 000
188 0 00000 000
189 0 00000 000
190 0 00000 000
191 0 00000 000
192 0 00000 000
193 0 00000 000
194 0 00000 000
195 0 00000 000
196 0 00000 000
197 0 00000 000
198 0 00000 000
199 0 00000 000
200 0 00000 000

```

ON

OFF

PROGRAM LOCK

DATA LOGGER

FIG. 4-10

to calculate the system performance parameters listed in Table 4-2. Subsequently the 15-minute data is utilized to define averaged daily performance such as output (Ton-hr), thermal coefficient of performance (COP) and electric energy efficiency ratio (EER). The 15-minute data are recorded on magnetic tapes which are periodically sent back to UTRC where they are processed to arrive at the daily averages. The daily averages are also used to prepare weekly and monthly performance summaries. Manual readings are taken of the two electric service power meters to provide a record of the consumption by the solar cooling system and by the electric backup units. This information can then be used to verify EER's calculated and summarized by the data reduction program.

A more detailed description of the data processed by the datalogger and the relationships used to define system performance parameters are contained in Appendix A. The functional operation of the Autodata Ten/5 datalogger are illustrated in Fig. 3-9.

The parameter, CODE listed above is an identification code number used to identify the reason for any shutdown initiated by the MODICON controller (See Table 4-4).

#### 4.1.5.1 Sensor Selection

The sensors used were selected on the basis of localized environmental conditions, effective range, accuracy, system compatibility reliability and ease of utilization. These were installed so as to minimize the effects of noise and common mode signals.

For temperature measurement, both RTD devices and thermocouples are used. Except for the turbocompressor seal temperature and the hot tank temperature which is used to control the solar collector loop 3-way valve, RTD's are used to measure temperature (referenced to 32 F). All temperature differences across components are measured by thermocouples. The temperature differences together with water flow rate measurements define the heat absorbed or rejected in a component such as a fan-coil unit. Pressure measurements are made by means of DC-DC pressure transducers. High quality (Rosemount) DC-DC transducers were selected for the measurement of the R11 pressures in the two air-cooled condensers, the evaporator and the vaporizer because of their superior accuracy. Accurate measurement of these parameters is important because they are used to define the performance and operational status of the chiller module. Water flows are measured by turbine flow meters which have been calibrated for the specified flow conditions. Electrical power consumption is measured by means of standard commercial Watt-hr meters.

TABLE 4-2  
 COOLING SYSTEM PERFORMANCE PARAMETERS RECORDED FOR  
 EACH 15-MINUTE TIME PERIOD

| <u>Item</u> | <u>Description</u>                 | <u>Units</u>           |
|-------------|------------------------------------|------------------------|
| IADR        | Ave. Solar Intensity               | Btu/hr ft <sup>2</sup> |
| QAC1        | Ave. Heat Flow from East Collector | Btu/min                |
| QAC2        | Ave. Heat Flow from West Collectoe | Btu/min                |
| QAVG        | Ave. Heat flow to Vapor Generator  | Btu/min                |
| QAEV        | Ave. Heat Flow from Evaporator     | Btu/min                |
| QAFC        | Ave. Heat Flow to Fan Coils        | Btu/min                |
| SUPR        | System up Ratio                    | --                     |
| ONTM        | Chiller On Time                    | --                     |

#### 4.1.5.2 Sensor Accuracy and Precision

Sensor accuracy must be interpreted in conjunction with the overall data acquisition system. Each sensor was calibrated as an isolated unit and also as part of a complete data channel. Sensor (e.g., flowmeter) calibrations supplied by the manufacturer were checked prior to installation using instruments that are periodically checked against sophisticated instruments at P&WA which in turn are referenced to the National Bureau of Standards. Channel precision from multiplexer and A/D converter to digital output are on the order of .025% FS,  $\pm 1$  LS digit. Internal conditioning of the sensor signals over the short and long term are continually checked electronically by the DAS.

#### 4.1.5.3 Evaluation of Error Effects on Measured Performance

A measurement system generally comprises a chain of components each of which is subject to individual inaccuracy. Such is the case in the measurement of the important solar cooling system performance parameters (e.g., heat flows, COP) from measured temperatures, pressure flow rates, etc. When the errors ( $\Delta u$ 's) are small and considered as a statistical bound rather than absolute limits of error, the proper method of, combining such errors for the computed parameter ( $u$ ) for  $n$  variables as the root-sum-square formula

$$Ea_{RSS} = \left[ \left( \Delta u_1 \frac{\partial f}{\partial u_1} \right)^2 + \left( \Delta u_n \frac{\partial f}{\partial u_2} \right)^2 + \dots + \left( \Delta u_n \frac{\partial f}{\partial u_n} \right)^2 \right]^{1/2}$$

The overall error  $Ea_{RSS}$  then has the same meaning as the individual errors. That is, if  $u_i$  represents a statistical limit on  $u_i$ , then  $Ea_{RSS}$  represents the same limit on  $N$ .

Using this relationship and the sensor accuracies defined in Table 4-3, the estimated instantaneous (i.e., based on measurements taken each minute) RSS errors in collector efficiency, heat flows and COP for representative high-load operating conditions are presented below. The instantaneous value of each parameter is used to calculate an average value for a 15-minute period. The standard error in the average value is  $\sqrt{2Si/n}$ , where  $Si$  is the instantaneous value of each parameter. Thus, the standard error in measuring the average value of each parameter is the instantaneous RSS error divided by  $\sqrt{15}$  as indicated below.

TABLE 4-3  
 SENSOR ACCURACY AND PRECISION

| <u>Sensor</u>                 | <u>Parameter</u>                                | <u>Accuracy/Precision</u> <sup>(1)</sup> |
|-------------------------------|-------------------------------------------------|------------------------------------------|
| Thermocouple                  | Single Temp.<br>Temp. Difference <sup>(2)</sup> | 2F<br>0.2F                               |
| RTD <sup>(3)</sup>            | Temperature                                     | 1F                                       |
| Press. Transducer             | Water Pressure                                  | 0.5% F.S.                                |
| Press. Transducer (Rosemount) | Rll Pressure                                    | 0.2% F.S.                                |
| Turbine Flow Meter            | Water Flow Rate                                 | 0.5% F.S.                                |
| Pyroheliometer                | Solar Insolation                                | 0.5% F.S.                                |
| Speed Pickup                  | Turbocompressor Shaft RPM                       | 0.03% F.S.                               |
| Watt-hr meter                 | Electrical Energy Consumption                   | 5 kWh                                    |
| Clock                         | Operating Time                                  | 1 sec                                    |

(1) Includes Signal Conditioning

(2) Copper/constantan used for  $\Delta T$  measurements

(3) With platinum windings, signal fed directly to DAS

| <u>Parameter*</u>             | <u>Instantaneous<br/>RSS Error, %</u> | <u>Standard Error of<br/>Averaged Value, %</u> |
|-------------------------------|---------------------------------------|------------------------------------------------|
| Collector Efficiency, %       | 1.3                                   | 0.34                                           |
| Heat Flow, Btu/min            |                                       |                                                |
| Solar Input                   | 1.2                                   | 0.31                                           |
| Vaporizer or Evaporator Input | 2.1                                   | 0.54                                           |
| Chiller COP                   | 2.9                                   | 0.75                                           |

#### 4.1.6 Central Control System

A programmable microprocessor-based control system was installed to provide overall control of the solar air conditioning system including the electric backup units. On-off control of the individual subsystems is accomplished in accordance with the overall logic diagram previously shown in Fig. 3-7 with one small exception. As currently installed, the collector/storage controller operates independently of the Modicon central controller. The Modicon controller, however, does perform its control functions in conjunction with output signals from the datalogger and the conditioned space control system.

The operational features of the chiller and space conditioning controllers are described in the following paragraphs.

##### 4.1.6.1 Chiller Controller

The Modicon controller which is the primary controller for the chiller was mounted on the north wall of the equipment room inside a Hoffman enclosure. All controls needed during normal chiller operation are located on the outside of the enclosure door (see Fig. 4-11). The detailed logic programmed into the Modicon for control of the chiller operation is shown in Fig. 4-12. The operational status is indicated and the control functions of the chiller are initiated by these buttons which are listed below.

| <u>Button</u>                            | <u>Description</u>         |
|------------------------------------------|----------------------------|
| RUN - amber indicator                    | Chiller Running            |
| EMERG. STOP - pushbutton/red indicator   | Emergency shutdown routine |
| CYCLE START - pushbutton/green indicator | Start chiller              |
| STOP - pushbutton/red indicator          | Stop chiller               |
| MAN/AUTO-switch                          | MAN - operator control     |
|                                          | AUTO - time clock control  |

\*See Appendix A for definitions of these performance parameters.

Blank Page

Blank Page

For normal operation, the MAN/AUTO switch is set to AUTO. To put the chiller online, the CYCLE START pushbutton is activated. The start cycle will continue provided the following three conditions have been met, namely: the safety permissives are satisfied, there is a demand for cold water (i.e., either chiller tank temperature is greater than the set point or the hot tank temperature is greater than 305 F), and the hot-tank permissive is satisfied.

Seven-safety permissives are utilized and protect against running at conditions that could do serious harm to the integrity of the equipment. These safety permissives are listed below.

|              |                                  |
|--------------|----------------------------------|
| . PB > PBMIN | Turbocompressor Bearing Pressure |
| . PV > PVMIN | Vaporizer Pressure (R11)         |
| . PV < PVMAX | Vaporizer Pressure (R11)         |
| . PE < PEMAX | Evaporator Pressure (R11)        |
| . PE > PEMIN | Evaporator Pressure (R11)        |
| . N < NMAX   | Turbocompressor RPM              |
| . TS < TSMAX | Turbocompressor Seal Temperature |

For example, protection is afforded against running at excessive turbocompressor seal temperatures and speeds or without sufficient pressure to provide a needed mixture of oil and refrigerant to the bearings. Similarly, operation at low R11 pressures in the evaporator protects against possible freezeup on the chilled water side.

The hot tank permissive (i.e., the operational permissive indicated in Fig. 4-12) is a starting requirement that insures a sufficiently high temperature to prevent surging of the chiller compressor and short cycling of the chiller (at least 30 minutes of operation prior to shutdown). The limiting value of the hot water (THS1) temperature is defined by the condenser conditions determined by the ambient cooling air temperature (TAMB) and evaporator conditions defined by the cold storage temperature (TCS1). Direct measurement of the condenser and evaporator temperatures is meaningless prior to chiller startup. The datalogger solves the following equations (using measured data) which approximates these relationships and provides a signal to the Modicon controller to continue the start sequence if and when THS1 is greater than TON.

where:  $TON = 4 * TAMB + K_5$

When the above demand, safety and operational permissives have been met, a GO signal is received which signifies that the starting sequence is in process. The various valves, pumps, fans, etc. will turn on in a specified sequence, while start-up permissives are monitored. The final indication that the chiller is online and running is when the AMBER RUN light turns ON. The chiller will continue to run so long as all monitored conditions are conducive to safe and efficient operation.

The chiller will shut down in either of two routines, Normal or Emergency (see Fig. 4-12). When the temperature in the cold storage tank drops to 45 F, a normal shutdown is initiated. A normal shutdown sequence is also initiated when operating conditions reach a state which results in low outputs (tons), low COP's and/or low EER's as defined by the chiller predicted performance map. The conditions indicative of inefficient operation are high condenser pressures (PFCC and PFPC) and low Rll pressures in the vaporizer (PFVG) and in the evaporator (PFEV). The datalogger solves the following equations (using measured data) which expresses these relationships and provides a signal to the Modicon controller to turn the chiller off when PFVG is less than POFF.

$$\text{where: } \text{POFF} = 6.81 \text{ PFPC} - 53.61$$

For an emergency shutdown, the RED light will remain lit during the shutdown sequence and stay lit after the system is shut down.

The conditions described above apply to daytime operation, at nighttime (after 5 PM and until 7 AM) the system will be OFF and the RED STOP LIGHT will be lit.

The system may be turned off manually at any time by pushing the STOP button. For this action the system will remain OFF and the RED STOP light will remain lit.

The following conditions indicate a malfunction:

1. The Emergency RED STOP lamp is lit
2. The Normal RED STOP lamp remains lit
3. The chiller continues cycling with no significant time period during which the AMBER RUN lamp is lit.

These conditions are caused by failure (opening) of one of the interlocks which are required to be closed for normal operation. To determine which interlock has failed, lights have been included inside the controller cabinet in the lower left-hand corner on annunciator panel marked "CHILLER INTLK." (See Fig. 4-13). If one of these lights is on, it is an indication that the interlock has opened and caused a shutdown. Table 4-4 presents a listing of the interlocks, the type of shutdown procedure which is used if the interlock should fail, and whether the interlock is "latched off" after a failure. If an interlock is latched off, the system will stay off until restarted manually, if it is not latched off the system will attempt to restart and if the problem has been alleviated by the shutdown, the system will operate in a normal mode, if the problem persists the system will shut down again and continue cycling.

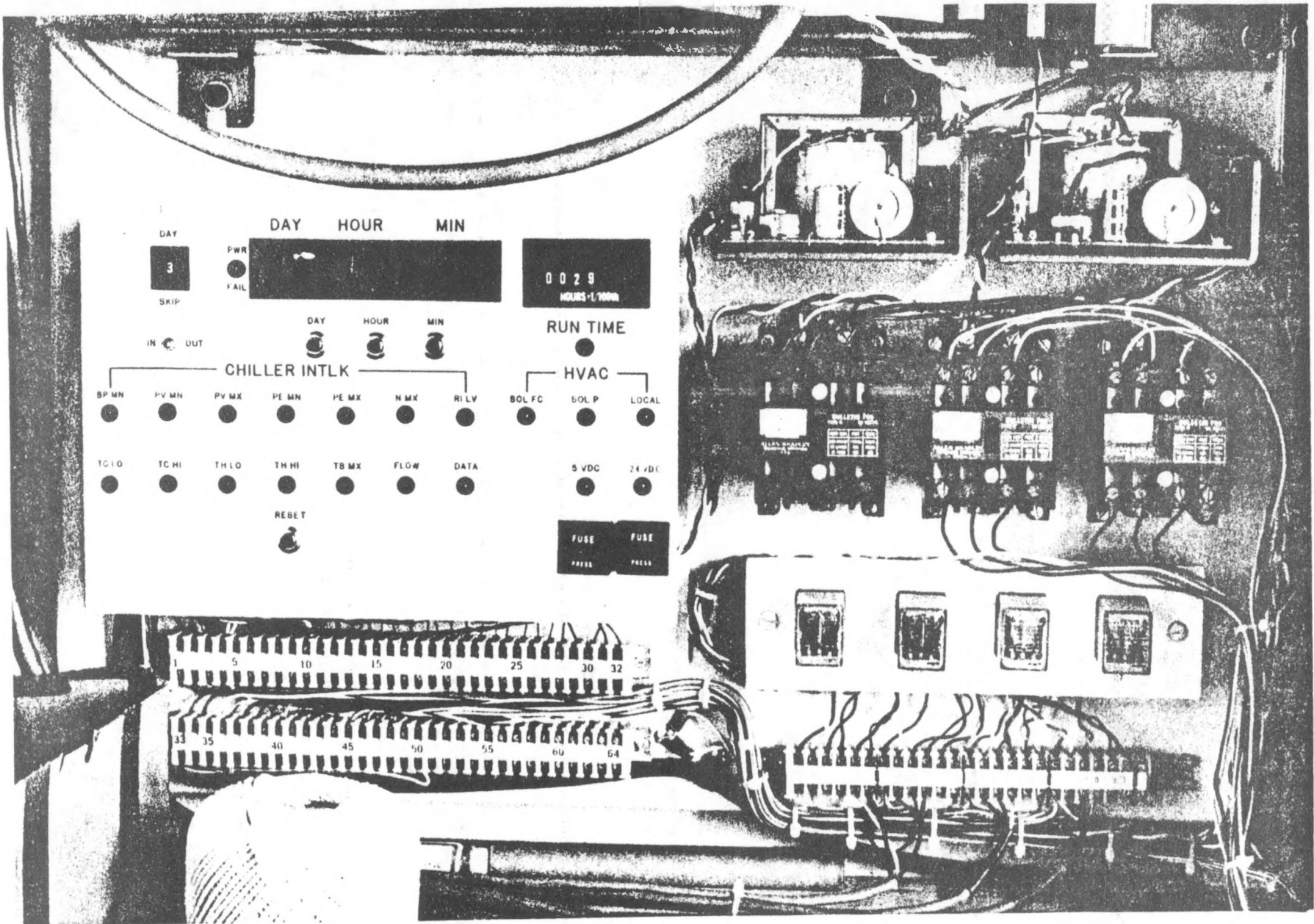

CHILLER INTERLOCK PANEL

FIG. 4-13

TABLE 4-4  
CHILLER INTERLOCKS

| <u>Code</u> | <u>Interlock</u> | <u>Latch</u> | <u>Shutdown</u> | <u>Description</u>               |
|-------------|------------------|--------------|-----------------|----------------------------------|
| 1           | PWR FAIL         | Yes          | —               | Power Failure                    |
| 2           | BP MN            | No           | Emergency       | Turbocompressor Bearing Pres.    |
| 3           | PV MN            | No           | Normal          | Chiller Vaporizer Pres. (Min.)   |
| 4           | PV MX            | Yes          | Normal          | Chiller Vaporizer Pres. (Max.)   |
| 5           | PE MN            | No           | Normal          | Chiller Evaporator Pres. (Min.)  |
| 6           | PE MX            | Yes          | Emergency       | Chiller Evaporator Pres. (Max.)  |
| 7           | N MX             | Yes          | Emergency       | Turbocompressor RPM (Max.)       |
| -           | RILV             | -            | -               | Not Used                         |
| 8           | TCL0             | No           | Normal          | Cold Storage Tank Temp. (Min.)   |
| -           | TCHI             | -            | -               | Not Used                         |
| 9           | PVLO             | No           | Normal          | Vaporizer Outlet Press (Min.)    |
| -           | THHI             | -            | -               | Not Used                         |
| 10          | TSMX             | Yes          | Emergency       | Turbocompressor Seal Temp. (Max) |
| 11          | Flow             | Yes          | Emergency       | Evaporator Cold Water Flow       |

#### 4.1.6.2 Space Conditioning Controls

Figure 4-14 shows a schematic of the control system installed for each fan-coil unit. Twenty-four (24) VAC is supplied to the select switch mounted between the solar and back-up thermostats on the wall. This switch selects back-up only, or solar air conditioning with the automatic back-up if the solar system cannot meet the load. The Modicon controller authorizes the solar air conditioning to come on by energizing relays R1, R2, and R3. R1 is energized weekdays between 0700 to 1700, R3 is energized at the same time, and when cold water is available in the cold tank. R2 is energized normally except between 06:45 and 07:45 in the morning. The conditions of these relays are displayed on the annunciator panel in the chiller controller shown in Fig. 4-13. When these relays are engaged and the select switch is in the solar position, the solar thermostat will control room temperature by activating the water pump to maintain a temperature within 1 F of the set point. If, for some reason, the temperature should rise higher than 2 F above the set point, a signal from the thermostat through R2 to the auxiliary relay will energize that relay, turning on the back-up air conditioning unit and shutting down the solar air conditioning subsystem.

Since the room temperature may be more than 2 F above the set point when the air conditioning comes on in the morning, the back-up system is disabled for one hour after start-up (by opening R2) to allow the solar system to cool down the room first.

The thermostats for the solar air-conditioning system have 4 controls on them. Their functions are:

- Set Points - Lever on top of thermostat
- Right-Hand Side (C) - controls room temperature setting during day time hours (0700 - 1700) within 1 F of set point. At 2 F above this set point, the solar air conditioning unit cuts out and the back-up unit comes on.
- Right-hand side (H) - inoperative.
- Fan Control - lever on bottom left of thermostat controls fan operation. AUTO turns fan on and off with thermostat. ON leaves the fan on whenever the solar air conditioning system is turned on.
- System Control - Level on bottom right of thermostat controls solar air conditioning operation. AUTO allows the system to operate with thermostat. OFF prevents the system from coming on.

The actual switch settings for correct operation of the system when air conditioning is required should be:

### SPACE CONDITIONING CONTROL

ONE FAN COIL ONLY

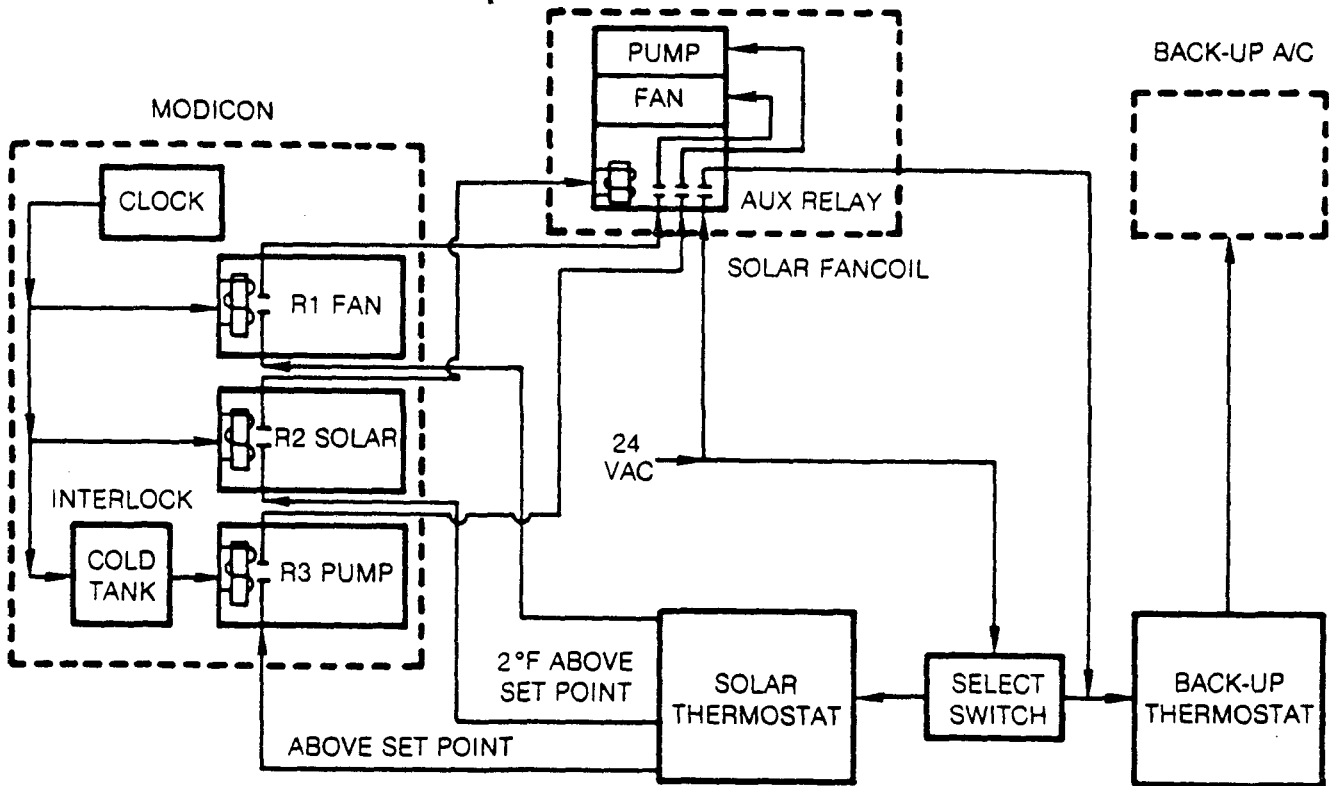

Select Switch - SOLAR

Solar Thermostat - Set Point - at desired temperature (~ 76 F)  
- Fan Control - ON  
- System Control - AUTO

Back-Up Thermostat - Blue Set Point - at same temperature as Solar  
Thermostat set point (~ 76 F)  
- Red Set-Back Point - at desired night time air  
conditioned temperature  
- Fan Switch - ON  
- System Switch - COOL

This will allow the solar air conditioning to maintain the daytime temperature unless it cannot meet the load, in which case the back-up system will take over. At night, the back-up system will automatically take over to maintain the setback temperature.

When heating is required, the solar thermostat should be left in its existing position, but the following switch positions should be selected:

Select Switch - BACK-UP

Back-Up Thermostat - Set Point and Back-up Set point, as desired.  
- Fan Switch - as desired  
- System Switch - HEAT

#### 4.2 Reliability and Maintainability Analysis

A reliability and Maintainability (R&M) analysis was conducted for the solar cooling system installed at the test site to ensure that the design goals are met and the system could be operated safely. One specific objective of this effort was to prepare forms for documenting and reporting repairs, failures and corrective actions which would occur during Phase III extended testing. The highlights of this analysis described in the following paragraphs relate primarily to the system installed.

Reliability has been defined for purposes of this study as the probability that equipment will perform a specified function under stated condition for a given period of time. The frequency of system failure varies with developmental status of the system, operating time and the number components. Development of the prototype is recognized as the period where mistakes due to design deficiencies, human error and similar factors are rectified.

If it is assumed that failure of any component will constitute system failure and component failure rate does not change with time, system reliability can be related to the product of the reliabilities of the individual components (or the sum of their failure rates). The failure rates for components used in the solar prototype system are based on data obtained from the manufacturers or reported statistical data on similar components. Based on the annual operating times given in Table 3-14, the analyses predicted prototype reliabilities of approximately 40, 65 and 88 percent for the collector/storage, chiller and thermal distribution subsystems, respectively. With these subsystem reliabilities the overall system reliability is approximately 23 percent.

In addition to the reliability analysis a failure mode and effect analysis (FMEA) was conducted to identify and remove failures that can cause hazards or might adversely affect functional reliability of the prototype system. Besides identifying failure mode, cause, and effect, attempts were made to describe the corrective action and estimate repair downtime.

A schedule for routine maintenance was also formulated. This schedule specifies actions to be taken, frequency and manpower required. Maintenance items and the schedule were summarized in Appendix C of Ref. 4 and are presented in detail in the Operating and Maintenance Manual prepared under separate cover (UTRC Report R81-955023-1). As part of this effort R&M data forms were prepared for use in the Phase III field tests. The purpose of these forms is to document all regularly scheduled and unscheduled actions taken and to establish to reliability of the prototype system. These forms not only record the nature of the failure and the action taken but also attempts to identify the failure cause.

This information on the prototype system would serve a useful purpose in the eventual design of commercial system and a prediction of its reliability and maintainability characteristics.

Blank Page

## 5.0 TESTING DOCUMENTATION

The testing documentation described in this section consists of checkout and acceptance tests conducted in Phase II of this program. Subsequent field testing for Phase III is reported in Section 6.0.

### 5.1 Checkout Tests

After completion of the solar cooling system installation, various checkout tests were conducted. These tests were carried out in late February and March 1981 prior to the acceptance test conducted on April 1. The checkout tests included operation, adjustment and performance verification of the collector/storage subsystem, chiller module, thermal distribution subsystem, all controls, DAS and data recording hardware. Both functional and performance checks were made. The entire solar cooling system was operated over a wide range of conditions in all manual and automatic operating modes. The performance and operation of each subsystem were generally consistent with analytical predictions. For example, the collector system was operated under the control of the local and master controller and routinely developed temperatures up to and over 300 F, collected and stored heat at efficiencies between 50 and 60 percent. The level of performance achieved on February 25 is only slightly below that estimated by the collector manufacturer as shown in Fig. 5-1.

The chiller was operated at conditions equivalent to ambient temperatures of 90 to 110 F with vaporizer water temperatures of 220 to 307 F. The performance achieved during these checkout tests are compared with predicted values in Figs. 5-2 and 5-3. The chiller delivered 8 to 20.5 tons of chiller water at 41 to 50 F and COP's were approximately equal to the values predicted for these conditions (0.4 to 0.70).

Each of the fan-coil units was operated in manual and automatic modes (under control of building thermostats) and each delivered in excess of their rated cooling output.

### 5.2 Acceptance Tests

Acceptance tests were conducted on April 1, 1981 to demonstrate the operational and performance capabilities of the UTC solar cooling system installation.

### SOLAR COLLECTOR CHECKOUT TEST DATA

DATE: 2/25/81

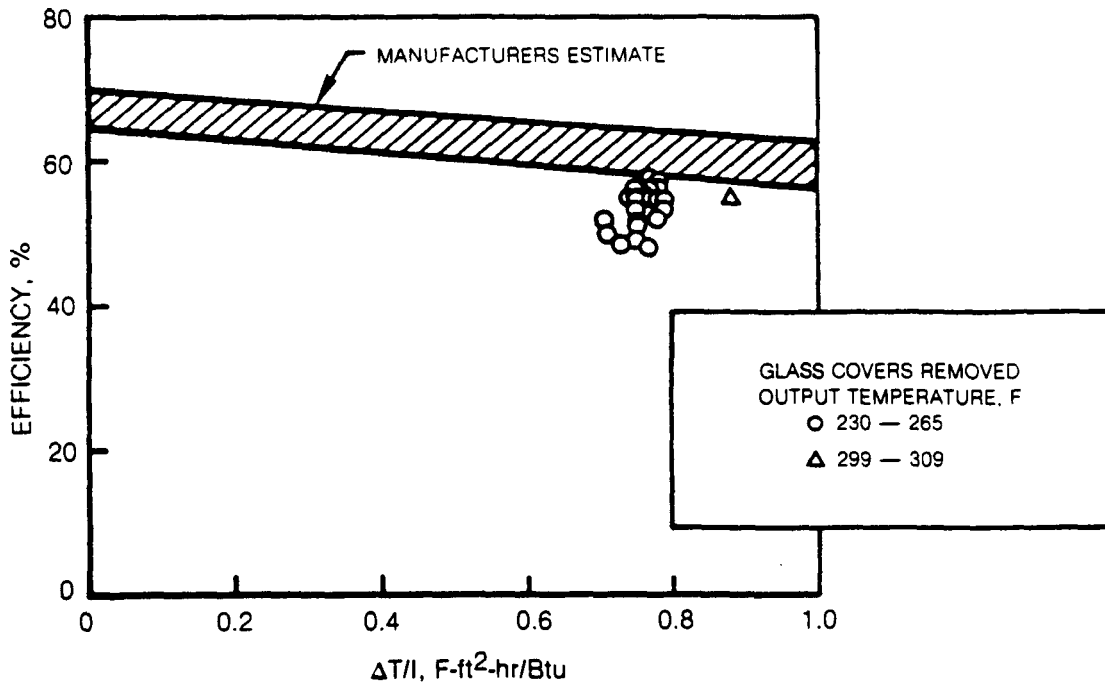

### CHILLER OUTPUT TEST DATA

CHILLED WATER TEMP = 41 — 50 F

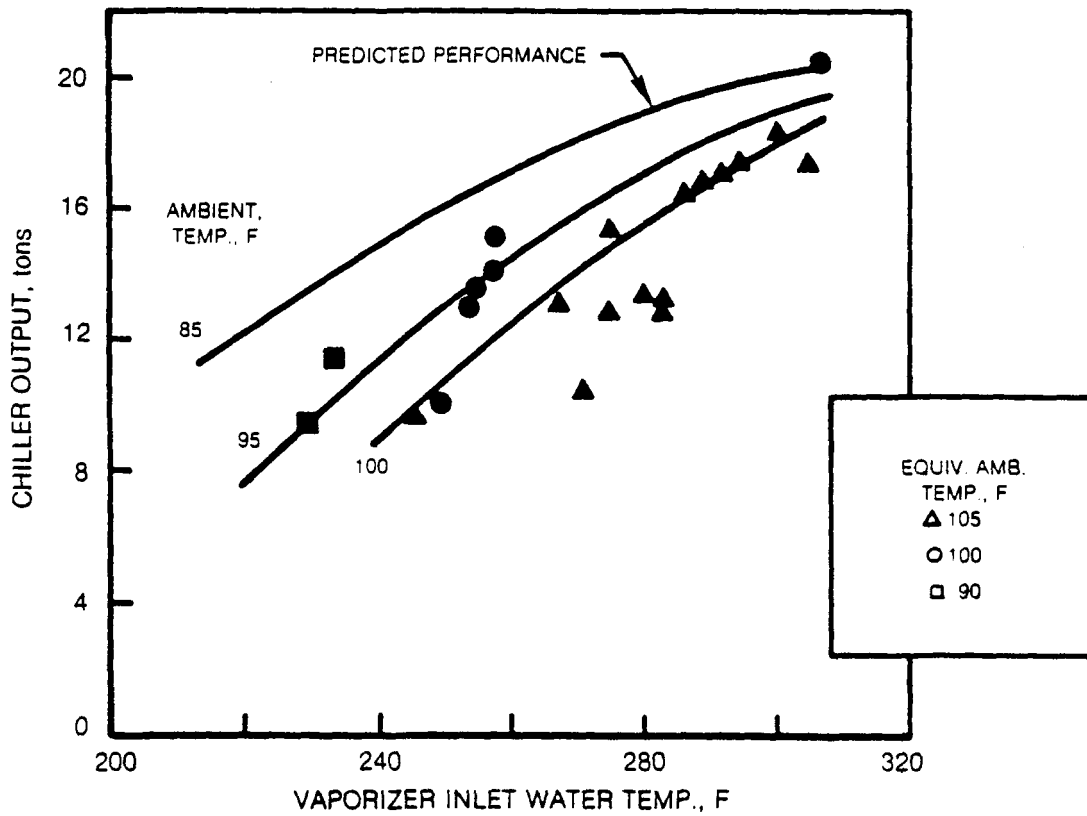

### CHILLER PERFORMANCE TEST DATA

CHILLED WATER TEMP = 41 — 50 F

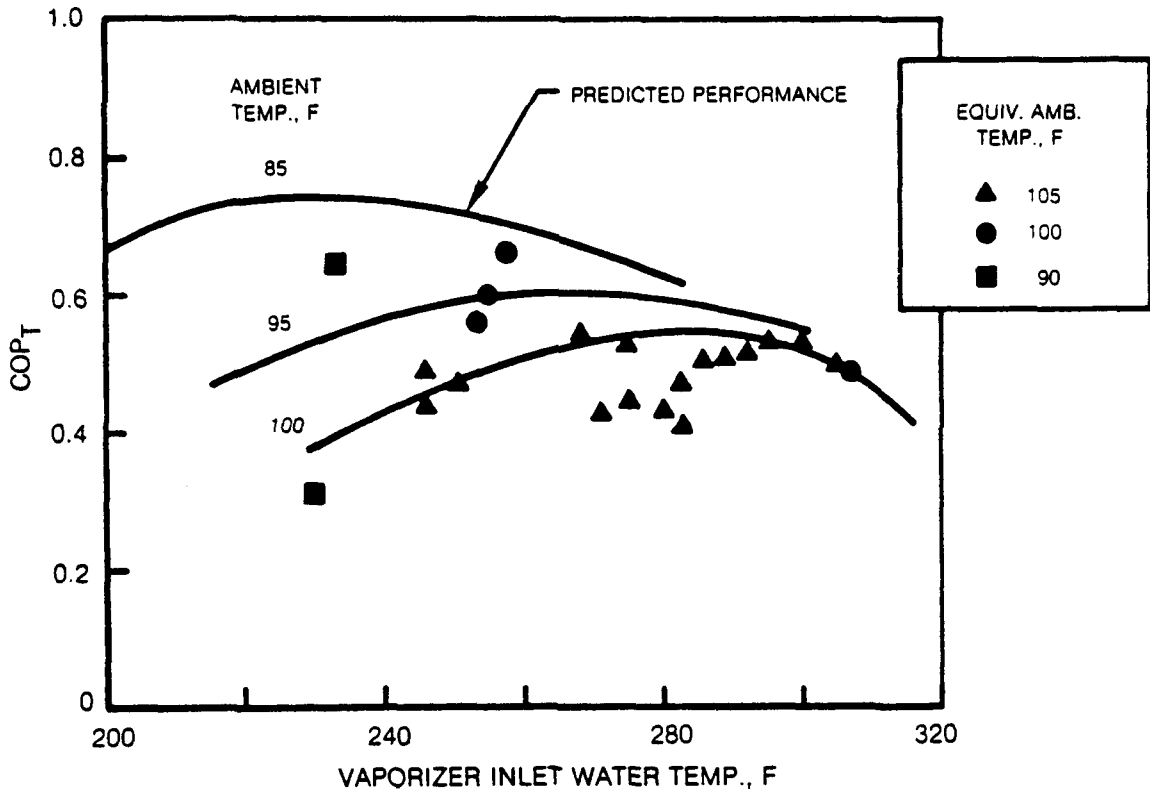

A series of tests were conducted wherein the collector/storage subsystem (master controller, local controller, differential T controller, and hot loop hardware - pumps, motors, valves, etc.); chiller subsystem (Modicon/DAS controllers, hardware - turbocompressor, pumps, relays, pressure switches, level controllers, bearing lube feed, purge unit) and building cooling subsystem (cold loop controls, thermostat controls, fan/coil units and water pumps) were operated in all normal and emergency modes. These tests were entirely successful, i.e., all subsystems and components operated normally. The complete solar system was operated for approximately 5 hours wherein the performance of each subsystem was documented. These collector/storage, chiller, and building cooling subsystems performance were all equal to or better than design predictions. For example, the collector efficiency approached 60 percent, chiller COP averaged 0.55 for 5 hours and ranged from 0.5 to 0.9, and each of the fan-coil units operated individually exceeded their nominal design output. Further details of checkout and acceptance test performance are provided in Figs. 5-4 thru 5-12, particularly the daily patterns of parameter variation. Detailed documentation of the acceptance test results is summarized in Tables 5-1 through 5-5. The operational tests and the performance achieved for each subsystem is described in the following paragraphs.

### 5.2.1 Operational Tests

#### 5.2.1.1 Collector/Storage Subsystem

All operating functions of the collector/storage subsystem were tested for proper action. The response to purposely altered input signals was observed to verify anticipated results. A summary of actual results is presented in Table 5-1. In the test of low insolation shutdown under a clear sky, the simple expedient of shading, the sun sensor was used. After successful shutdown, the shading was removed, and successful restart, acquire and tracking was observed.

During tests of these same functions under an actual intermittently cloudy period, the west collector row failed to acquire the sun after restart due to improper sensitivity adjustment of the tracking sensors. After sensitivity adjustments were made, the function was retested and proper operation was noted.

No other anomalies were encountered.

#### 5.2.1.2 Chiller Subsystem

The chiller subsystem is automatically operated by the Modicon/DAS controller. Although the Modicon/DAS controller serves many functions, its most important function is to control the operational functions of the chiller module. All

### SOLAR COOLING SYSTEM CHECKOUT TEST DATA

DATE: 2/23/81

COOLING CONDENSER  $T_{SAT} = 115 - 120$  F

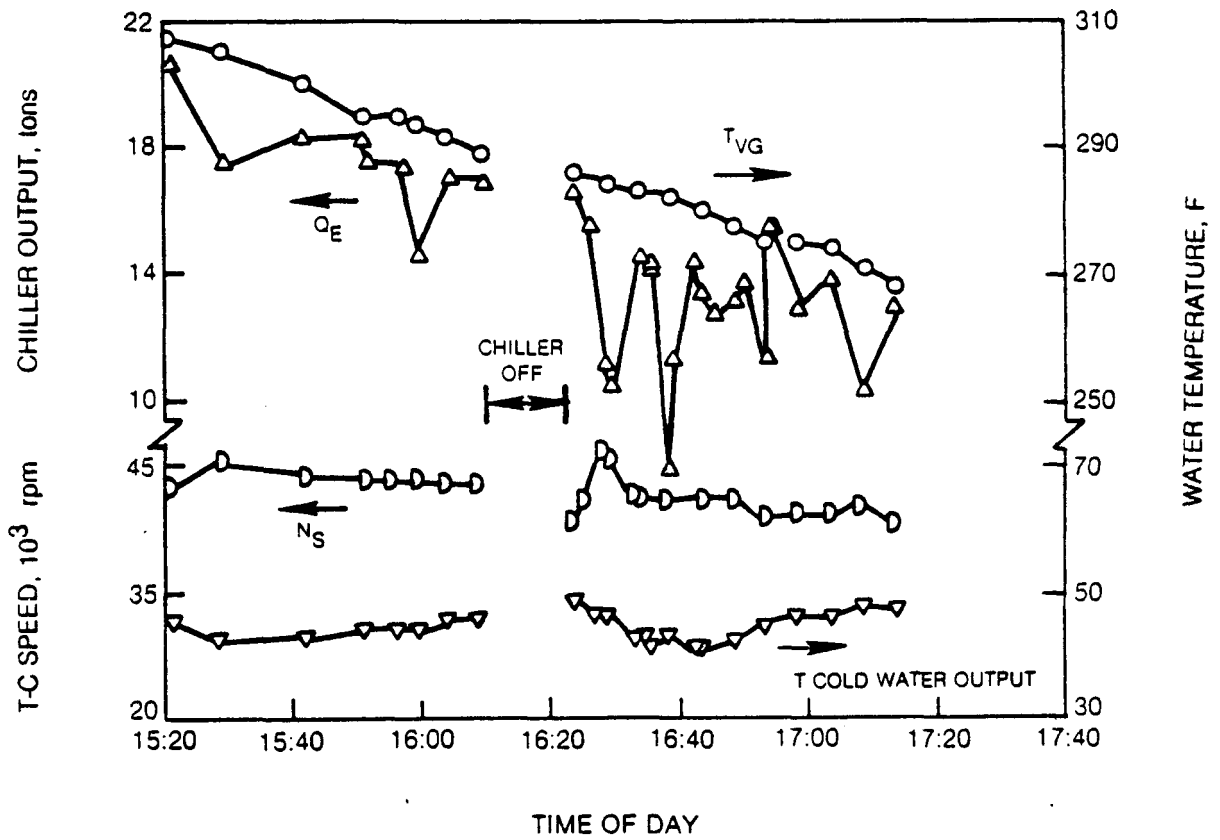

### SOLAR COOLING SYSTEM CHECKOUT TEST DATA

DATE: 2/25/81  
CHILLED WATER TEMP = 44 - 50 F

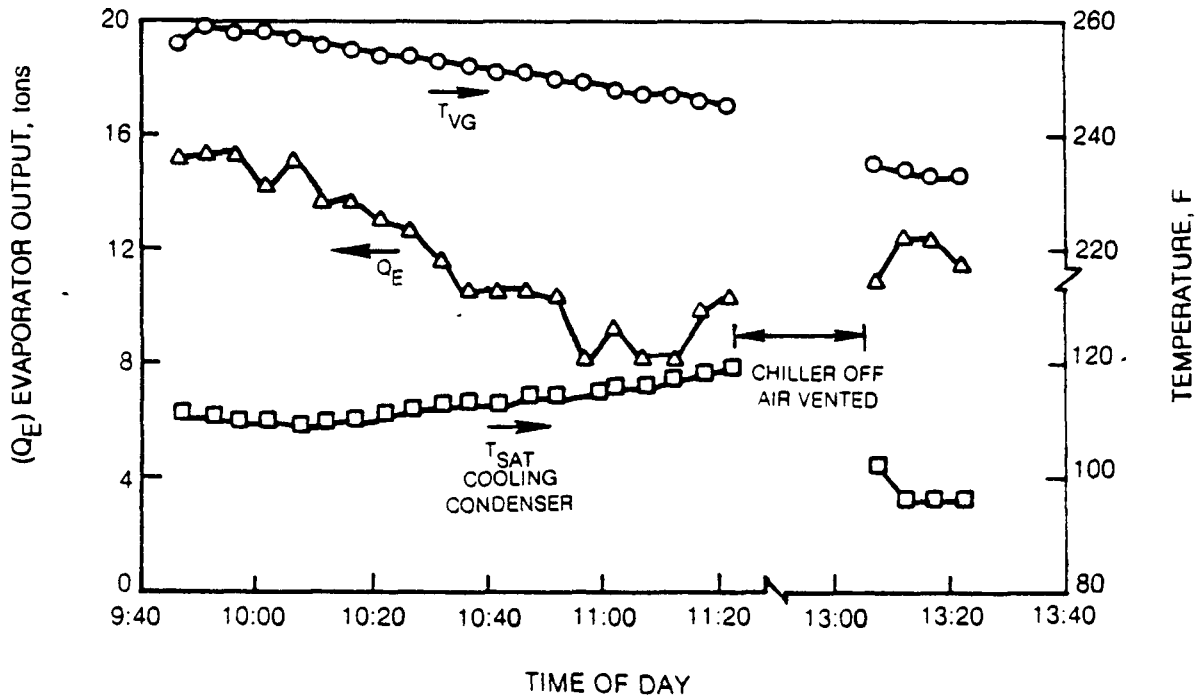

### SOLAR COOLING SYSTEM ACCEPTANCE TEST PERFORMANCE

DATE: 4/1/81

CONDENSER SATURATION TEMP = 100 - 110 F

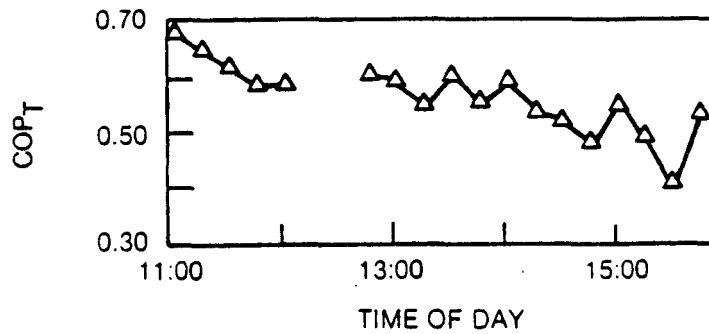
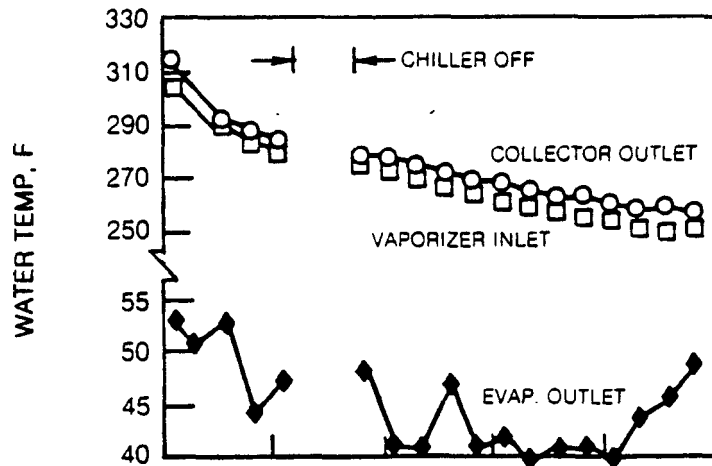
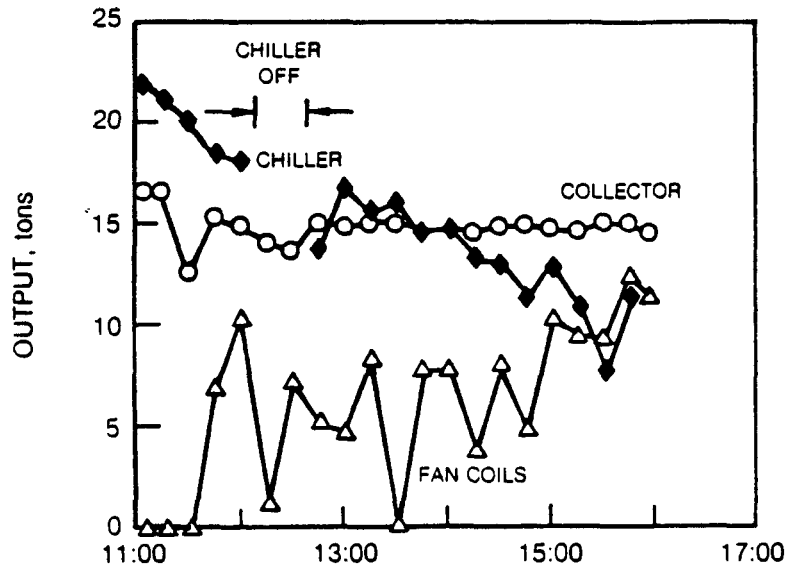

### UTRC SOLERAS INSTALLATION

MAY 8, 1981 TEST DATA

INSOLATION

○ IADIR

× IANOR

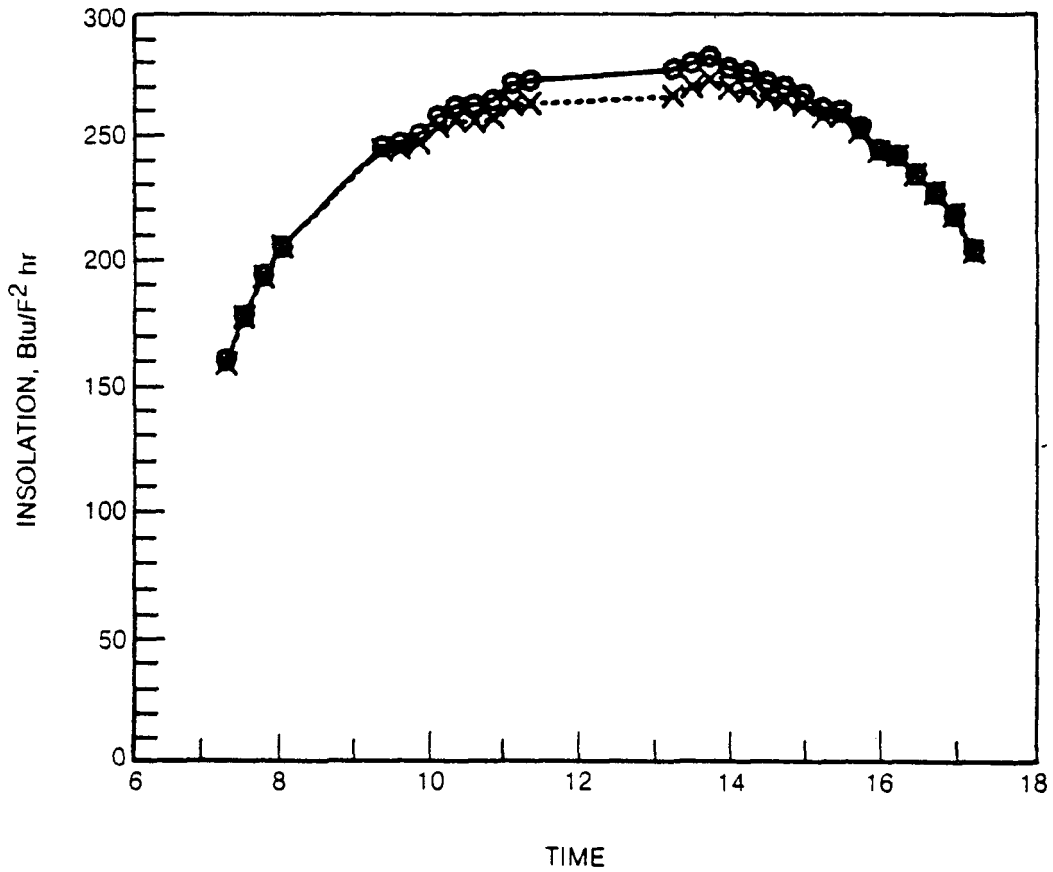

### UTRC SOLERAS INSTALLATION

MAY 8, 1981 TEST DATA  
COLLECTOR EFFICIENCY

○ ETAC1  
× ETAC2

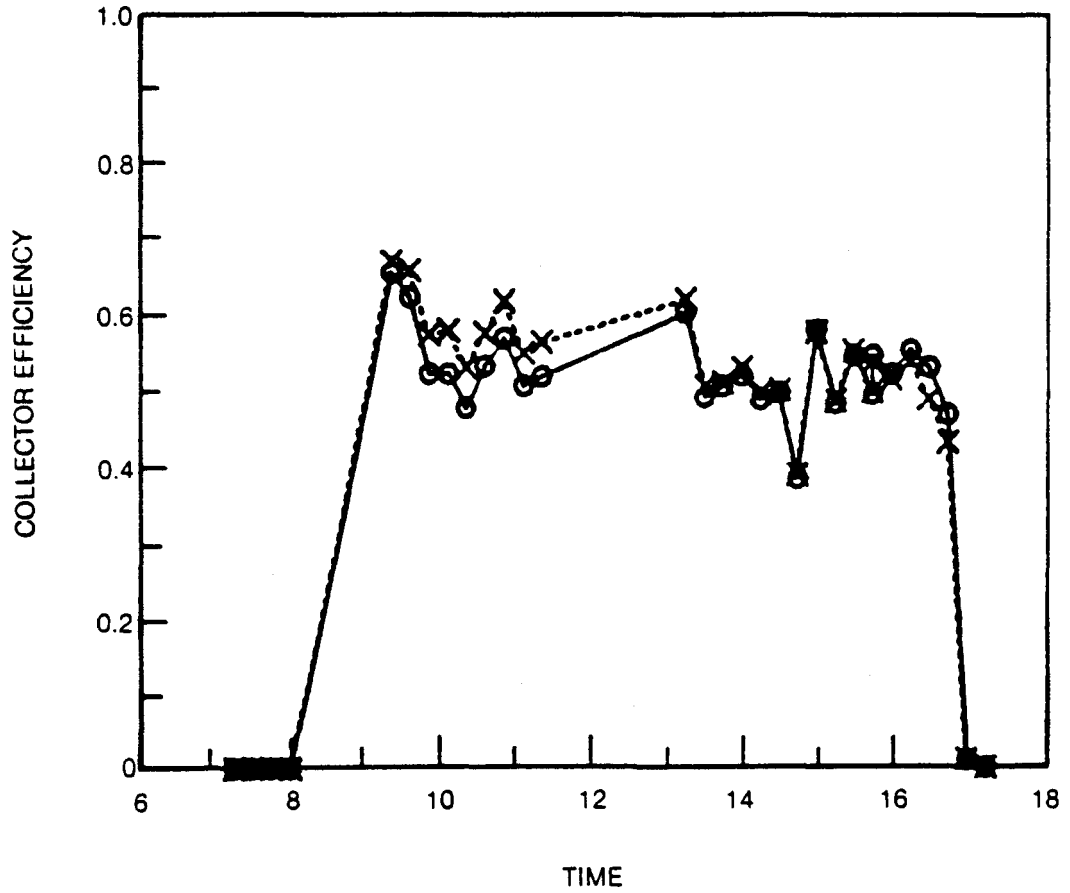

### UTRC SOLERAS INSTALLATION

MAY 8, 1981 TEST DATA  
POWER LOOP TEMPERATURES

○ TAMB      △ TFVG  
× TSPC      □ TWVG

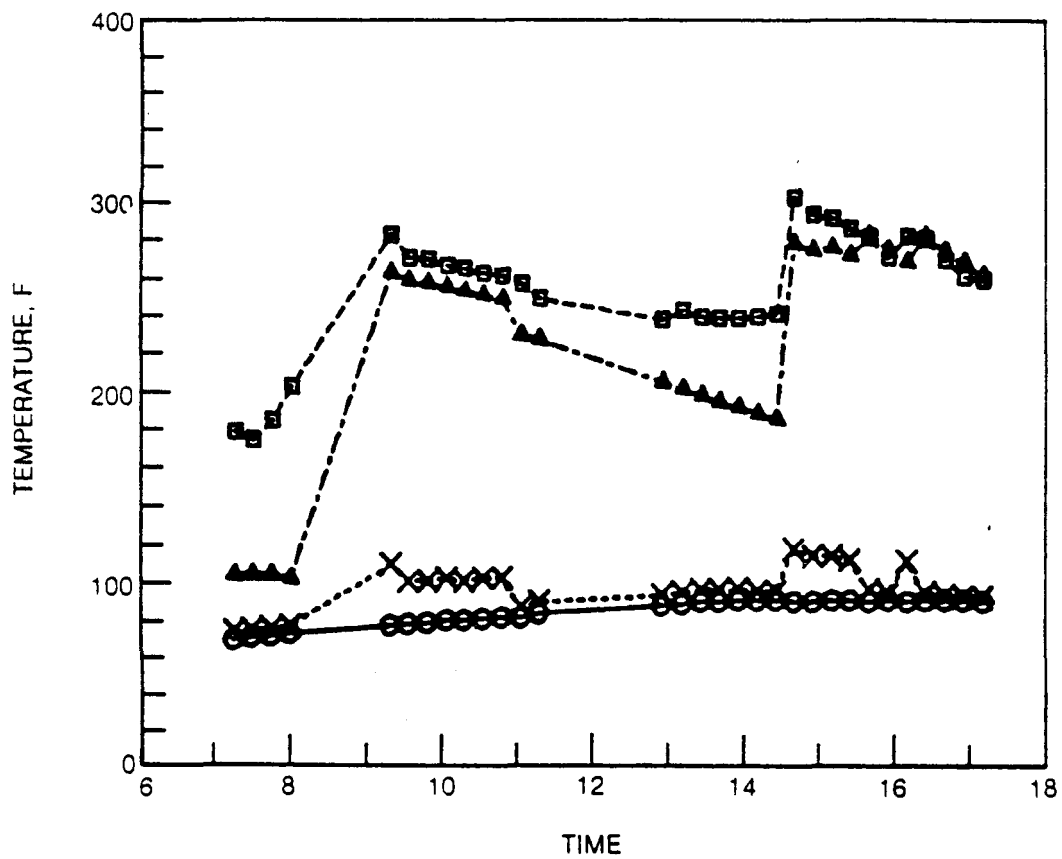

### UTRC SOLERAS INSTALLATION

MAY 8, 1981 TEST DATA

COOLING LOOP TEMPERATURES

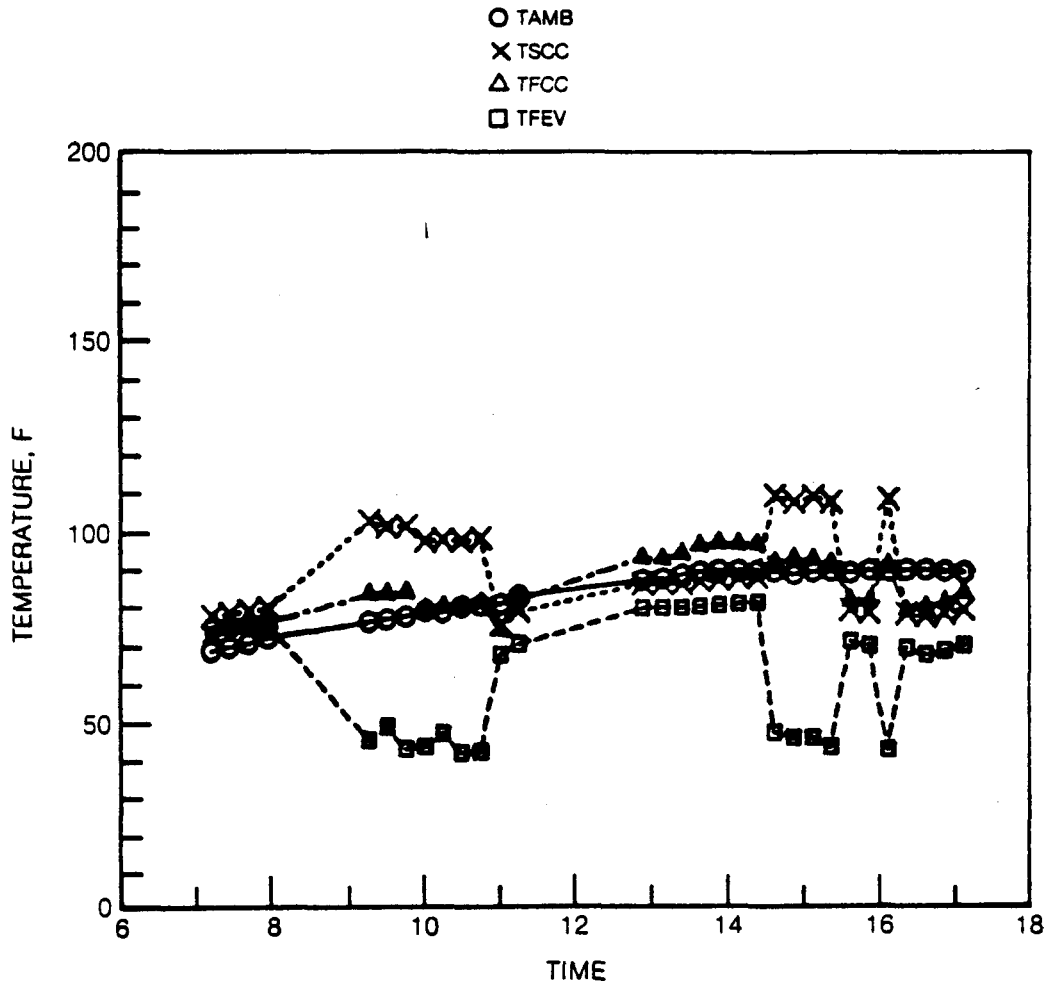

### UTRC SOLERAS INSTALLATION

MAY 8, 1981 TEST DATA  
CHILLER INPUT AND OUTPUT

○ QAVG  
× QAEV

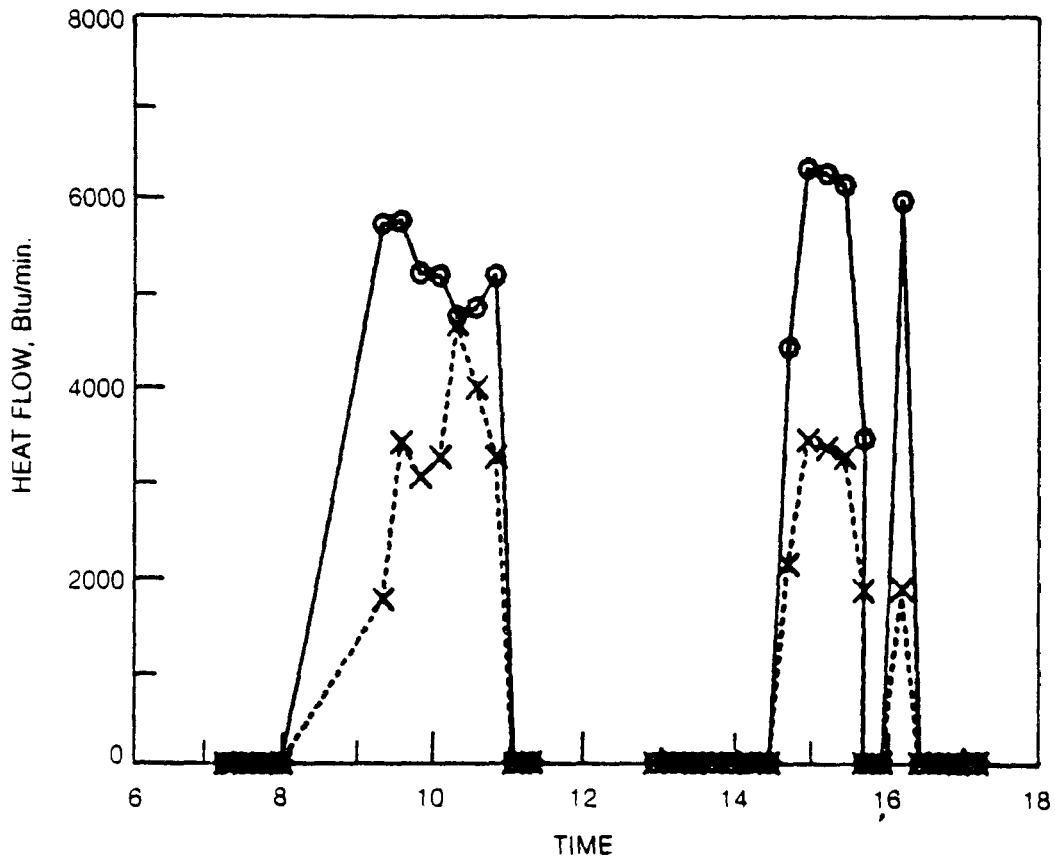

### UTRC SOLERAS INSTALLATION

MAY 8, 1981 TEST DATA  
CHILLER PERFORMANCE

○ TONS  
× COP

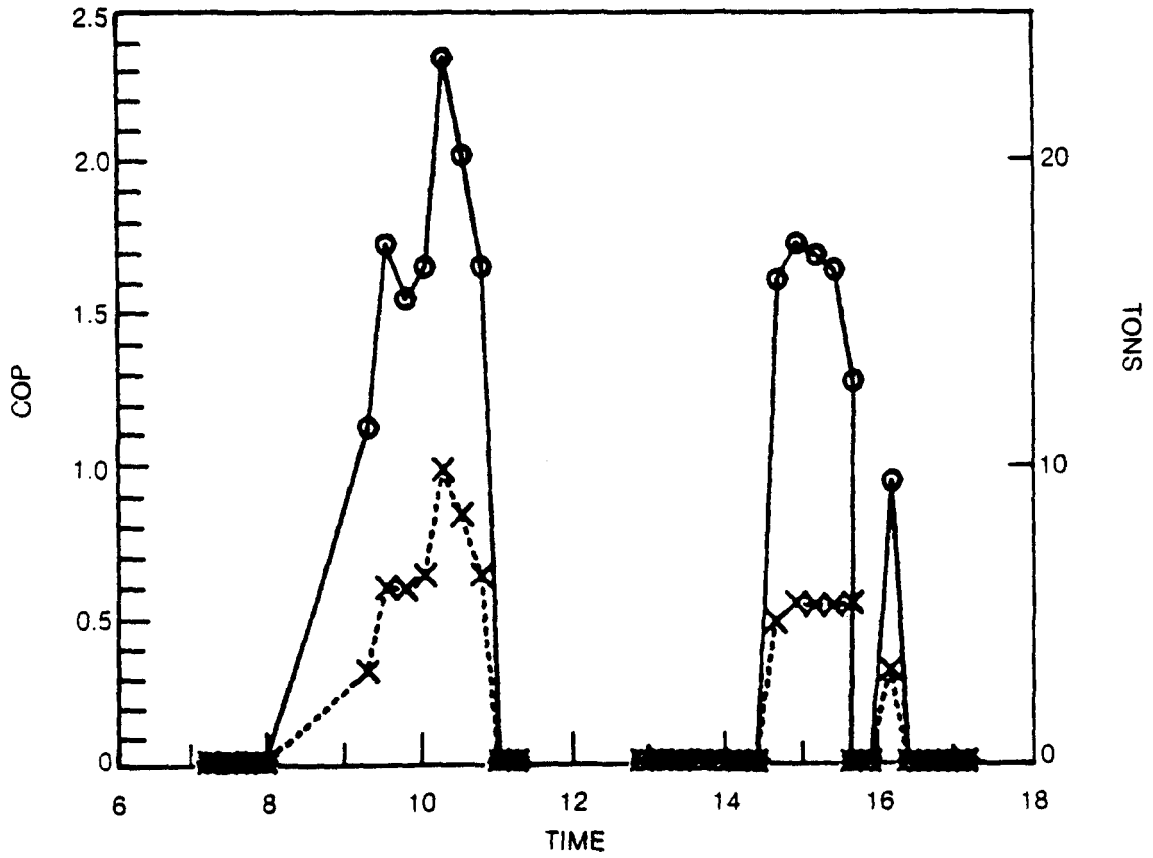

TABLE 5-1

## OPERATIONAL ACCEPTANCE TEST RESULTS

April 1, 1981

Collector/Storage Subsystem

| <u>Item</u>                         | <u>Function</u>                    | <u>Performance</u> |                 |
|-------------------------------------|------------------------------------|--------------------|-----------------|
|                                     |                                    | <u>East Row</u>    | <u>West Row</u> |
| Master/Local                        |                                    |                    |                 |
| Controllers                         | - Wake up and Shutdown             | O.K.               | O.K.            |
|                                     | - Acquire and Track                | O.K.               | O.K.            |
|                                     | - Flow Interlock Stop/Start        | O.K.               | O.K.            |
|                                     | - Demand Signal Stop/Start         | O.K.               | O.K.            |
|                                     | - Low Insolation Shutdown          | O.K.               | O.K.            |
|                                     | - Restart, Acquire and Track       | O.K.               | O.K.            |
| <u>Intermittent Cloud Condition</u> |                                    |                    |                 |
|                                     | - Low Insolation Shutdown          | O.K.               | O.K.            |
|                                     | - Restart, Acquire and Track       | O.K.               | O.K.*           |
| Differential $\Delta T$             |                                    |                    |                 |
| Controller                          |                                    |                    |                 |
| (Hot Tank)                          | - Operational Logic                |                    | O.K.            |
|                                     | - Bypass until $\Delta T > 10F$    |                    | O.K.            |
|                                     | - To storage with $\Delta T > 10F$ |                    | O.K.            |
|                                     | - Bypass with $\Delta T < 3F$      |                    | O.K.            |
| Hardware - pumps,                   |                                    |                    |                 |
|                                     | drive motors,                      |                    |                 |
|                                     | motor driven                       |                    |                 |
|                                     | valves                             | - Start, Run, Stop | O.K.            |

---

\* See discussion page 5-5

TABLE 5-2

## OPERATIONAL ACCEPTANCE TEST RESULTS

April 1, 1981

| <u>Chiller Subsystem</u>                    |                            |                    |
|---------------------------------------------|----------------------------|--------------------|
| <u>Item</u>                                 | <u>Function</u>            | <u>Performance</u> |
| Modicon/DAS Controllers                     | - Auto sequence start, run | O.K.               |
|                                             | - Normal stop & restart    | O.K.               |
|                                             | - Emergency stop & restart | O.K.               |
| Hardware - pumps, turbo-compressors         | - Start, run, stop         | O.K.               |
| . Solenoid valves, re-lays, press. switches | - Open, close              | O.K.               |
| . Level Controllers                         | - Modulate                 | O.K.               |
| . Bearing Lub. Feed Sub-system              | - Charge, recharge         | O.K.               |
| . Purge Unit                                | - Vent Noncondensibles     | O.K.               |

TABLE 5-3

## OPERATIONAL ACCEPTANCE TEST RESULTS

April 1, 1981

Building Cooling Subsystem

| <u>Item</u>                     | <u>Function</u>                                            | <u>Performance</u> |
|---------------------------------|------------------------------------------------------------|--------------------|
| Cold Loop/Tank                  | - Charge/Discharge                                         | O.K.*              |
| Thermostat Controls             | - Solar Mode Auto. On, run, off<br>Auto. switch to back up | O.K.               |
| Fan-Coil Units & Water<br>Pumps | - Start, run, stop                                         | O.K.               |
| Water Flow Controllers*         | - Maintain Design Flow Rate                                | O.K.               |

---

\* See discussion Page 5-20

TABLE 5-4

## THERMAL PERFORMANCE ACCEPTANCE TEST RESULTS

April 1, 1981

| <u>Subsystem</u>                  | <u>Test Conditions</u>                                     | <u>Performance</u>   |                                               |             |                               |               |             |            |
|-----------------------------------|------------------------------------------------------------|----------------------|-----------------------------------------------|-------------|-------------------------------|---------------|-------------|------------|
|                                   |                                                            | <u>Test</u>          | <u>Design</u>                                 |             |                               |               |             |            |
| Collector/<br>Storage             | Clear Sky                                                  | $Q_o = 3328$ Btu/min | 3235 Btu/min                                  |             |                               |               |             |            |
|                                   | Direct Normal Insolation = 299.9<br>Btu/ft <sup>2</sup> hr | $T_{out} = 298$ F    | --                                            |             |                               |               |             |            |
|                                   | Sun Angle $\theta = 25.8^\circ$                            | $\Delta T/I = 0.8$   | 0.8                                           |             |                               |               |             |            |
|                                   |                                                            | $\eta_c = 57.6\%$    | 56% (flex-<br>hose uninsulated)               |             |                               |               |             |            |
| <u>Chiller</u>                    | <u><math>T_{VG}/T_{eq. amb.}/T_{e_o}</math>, F</u>         |                      | <u><math>Q_o</math>, Tons/COP<sub>T</sub></u> |             |                               |               |             |            |
|                                   | 308                                                        | 90                   | 54 F                                          | 22.1 0.68   |                               |               |             |            |
|                                   | 300                                                        | 90                   | 51                                            | 20.5 0.704  |                               |               |             |            |
|                                   | 284                                                        | 90                   | 47                                            | 19.3 0.65   |                               |               |             |            |
|                                   | 287                                                        | 90                   | 44                                            | 17.5 0.56   |                               |               |             |            |
|                                   | 240                                                        | 80                   | 54                                            | 15 0.86     |                               |               |             |            |
|                                   | 5 hr operation average                                     |                      |                                               | 14 0.55     |                               |               |             |            |
| <u>Thermal Distri-<br/>bution</u> | <u>Unit Status</u>                                         |                      |                                               |             | <u>Test</u>                   | <u>Design</u> |             |            |
|                                   | <u>Evap. Pump</u>                                          | <u>FC-3</u>          | <u>FC-2</u>                                   | <u>FC-1</u> | <u><math>Q_o</math>, tons</u> | <u>GPM</u>    | <u>Tons</u> | <u>GPM</u> |
|                                   | ON                                                         | ON                   | OFF                                           | OFF         | 7.0                           | 19            | 5           | 16         |
|                                   | ON                                                         | OFF                  | ON                                            | OFF         | 6.5                           | 14            | 5           | 16         |
|                                   | ON                                                         | OFF                  | OFF                                           | ON          | 8.5                           | 22            | 7.5         | 22.5       |
|                                   | ON                                                         | OFF                  | ON                                            | ON          | 10.5                          | 32            | 12.5        | 38.5       |
|                                   | OFF                                                        | ON                   | ON                                            | ON          | 16.5                          | 42.4          | 17.5        | 54.5       |

TABLE 5-5

## ACCEPTANCE TEST AUXILIARY POWER MEASUREMENTS

April 1, 1981

| <u>Item</u>          | <u>Test Conditions</u>    |                         |                         | <u>Power, Draw, kW</u> |
|----------------------|---------------------------|-------------------------|-------------------------|------------------------|
| Chiller Refrig. Pump | $\Delta P = 106$ psi      |                         |                         | $\sim 2.8$             |
| Condenser Fans       | <u>T<sub>amb</sub>, F</u> | <u>Number Operating</u> | <u>Blade Angle, Deg</u> |                        |
|                      | 74                        | 1                       | 30                      | 0.875                  |
|                      | 74                        | 1                       | 20                      | 0.475                  |

Design Multi-Fan Schedule

| <u>T<sub>amb</sub>, F</u> | <u>Number Operating</u> | <u>Blade Angle, Deg</u> |       |
|---------------------------|-------------------------|-------------------------|-------|
| < 75                      | 2                       | 20                      | 1.80* |
| 70-80                     | 3                       | 20                      | 2.85* |
| 80-85                     | 4                       | 20                      | 3.60* |
| > 85                      | { 4<br>1 }              | { 20<br>30 }            | 5.35* |

\*  
Estimated

operational sequences were tested and the functional response of all elements of the chiller module monitored. The results of these tests are summarized in Table 5-2. All functions were found to operate flawlessly with performance parameters in agreement with predicted values.

#### 5.2.1.3 Thermal Distribution Subsystem

Results of testing of the building thermal distribution subsystem which provides cooling are summarized in Table 5-3. All tested functions operated as anticipated.

Evaluation of the acceptance test results, however, indicated the water flow to the fan/coils (f/c) was partially bypassing the cold storage tank. When all f/c's were operating simultaneously and the chiller output was less than the total f/c loads, the space conditioning subsystem performance was disrupted. Although this characteristic would have little impact on the annual solar contribution of the installation if the chiller instrumentation and control strategy were modified, it was simpler to make a change in cold water plumbing to eliminate this characteristic without control or instrumentation changes. This plumbing change was subsequently implemented and is reflected in the solar cooling system plumbing diagram presented in Fig. 4-8. Specifically, by adding a separate water line between the chiller and cold tank, rather than sharing a line with the f/c feed and replacing the evaporator loop check valve with a spring loaded model, the f/c feed water flow rate and distribution were improved with attendant performance improvement.

#### 5.2.2 Thermal Performance Tests

The results of the thermal performance tests conducted as part of the system acceptance test are summarized in Table 5-4.

System performance was evaluated from a set of approximately 50 measurements which were processed through the Acurex Autodata Ten/5 data acquisition system and stored on magnetic tape. These data included instantaneous values of system operating parameters (temperature, pressure, flow rates, speed) taken every 15 minutes and average values of heat flow rates which are calculated (by the DAS) from basic flow and temperature measurements obtained every minute but averaged over the 15 minute time interval. The data stored on the magnetic tape was further processed back at UTRC to obtain the system performance parameters such as chiller tonnage, COP, and collector efficiency.

#### 5.2.2.1 Collector/Storage Subsystem

As shown in Table 5-4, the collector subsystem performance was in excellent agreement with design values. Solar energy collection rate and collector efficiency exceeded predictions. It should be noted that the design values included allowance for heat loss from uninsulated lines, while in the actual installation insulation was used.

#### 5.2.2.2 Chiller Module

Chiller performance results are listed for the range of hot water temperatures supplied to the vapor generator. Chilled water temperatures produced ranged from 44 to 54 F with cooling ranging from 15 to 22.1 tons. Coefficients of Performance of 0.56 to 0.86 were measured. The average for a full 5 hours of operation was 14 tons of cooling produced with an average COP of 0.55.

#### 5.2.2.3 Thermal Distribution Subsystem

Test performance results for the building cooling subsystem listed in Table 5-4 shows that individual fan/coils provided in excess of their rated tonnage with chilled water flow rates near design values. Performance with multiple units operating was below design values. This condition has been rectified by the changes to the cold water distribution plumbing previously described.

#### 5.2.3 Auxiliary Power

Auxiliary power measurements made during shakedown and acceptance tests are presented in Table 5-5. Based on the measured values, power draw for the multi-fan configurations controlled by measured ambient temperature is estimated.

Blank Page

## 6.0 PROTOTYPE SYSTEM TEST

Following completion of shakedown and acceptance testing of the installed prototype system, routine operation was initiated. The SOLERAS Program Office conducted a commissioning ceremony at the UTC installation on June 24, 1981. In attendance at this commissioning were Ambassador Holsey G. Handyside, Chairman SOLERAS Executive Board; Dr. Rida Obaid, Executive Director and Chairman of the Board of the Saudi Arabian National Center for Science and Technology; Bruce E. Babbitt, Governor-State of Arizona; Margaret T. Hance, Mayor-City of Phoenix; Mr. James F. Warnock, Jr. Executive Director-Arizona Solar Energy Commission; representatives of the U. S. Department of Energy and Treasury Department including Dr. Robert San Martin, several Saudi Arabian Universities, the SOLERAS program and the UTC program team (see Table 1). Ambassador Handyside presented a commemorative plaque at the commission ceremony to Dr. Wayne G. Burwell, Director of Research UTRC (Fig. 6-1). The completed installation (Figs. 6-2 and 6-3) was inspected by all of the commissioning ceremony guests, the press, and television as it operated through the day with the ambient temperature reaching ~ 114 F.

A brief description of the solar system operation is presented in the following paragraphs. The solar cooling system has solid-state controls and datalogger for automatic operation and data acquisition during the system demonstration period. Under normal operation it is sufficient to turn the system on, and it will provide room conditioning from 7 AM to 5 PM Monday through Friday. Under normal conditions the system operates as follows:

#### Collector

When the solar intensity is above a minimum (trip point) intensity, the collector system is activated, the solar collectors track the sun and heats the water flowing through the receiver tubes. This hot water is stored in the hot-storage tank. This process will continue until the temperature of the water in the storage tank reaches 300 F. When this temperature is reached, the collectors will stow (to upside down position). They will also stow when the sun's intensity is below the trip point, or at night, or when the wind velocity is above 25 mph.

#### Chiller

When the temperature at the bottom of the cold-storage tank is above 55 F, the chiller is turned on to make more cold water, provided there is adequate hot

SOLERAS COMMISSIONING CEREMONY

R82-955027-2



FIG. 6-1

COMMISSIONING GUESTS VIEWING COMPLETED SOLAR COOLING INSTALLATION

R82-955027-2

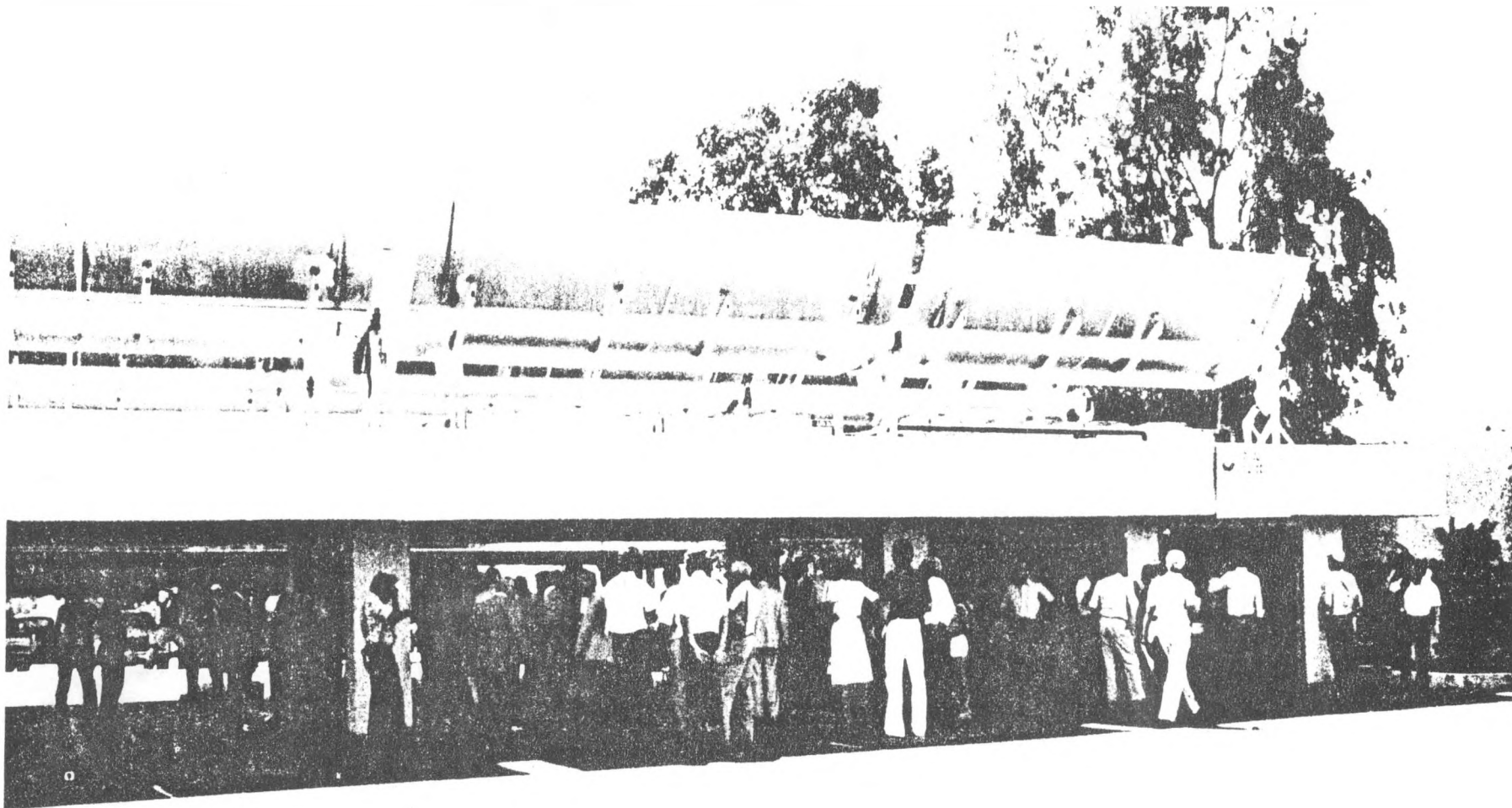
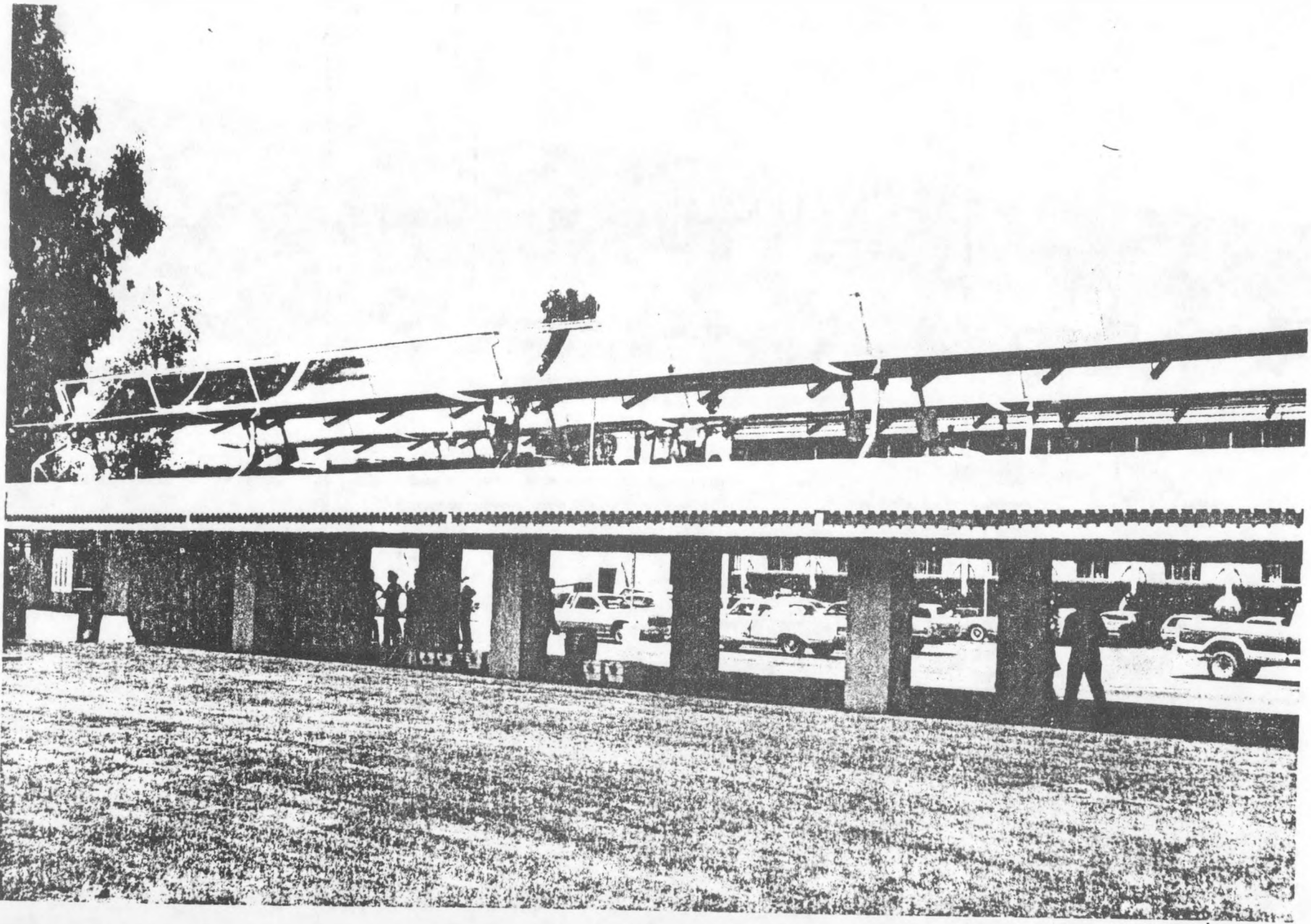

FIG. 6-2

6-3

COMPLETED SOLAR COOLING INSTALLATION

R82-955027 2



6-4

FIG. 6-3

water and other permissives are met. The chiller will continue to run until the temperature at the top of the cold tank reaches 45 F or until the temperature of the hot water drops too low to run the machine.

Space Conditioning

When any of the three zone thermostats call for cooling, the fan-coil unit in that zone will turn on. A feed pump will circulate cold water from the cold storage tank to the fan-coil. This will continue until the room cooling needs are met. If room cooling needs are not satisfied by the solar cooling system (i.e., room temperature goes two degrees over the set point), the "backup" system will go on.

This mode of operation was continued in the 1981 cooling season from April through mid-September and again in the 1982 cooling season from February through October.

During this operation, the automatic Data Acquisition System recorded measurements of more than fifty (50) parameters to determine system status and performance. The data was stored on magnetic tape and processed by computer at UTRC to provide an assessment of the field test system operation.

The following sections provide a summary of the huge volume of operational and performance data recorded together with typical examples of processed data.

## 6.1 Operational Data Summary

The UTC solar cooling system passed the acceptance tests at the end of March, and routine operation was initiated on April 1, 1981. During the first quarter through June 30, 1981, the system was operational except for the two periods during which it was shut down to accommodate minor modifications to improve its operational characteristics and to perform minor maintenance. The only significant difficulty encountered was associated with getting the data acquisition and recording system operational. The collectors and chiller ran regularly and performed in accordance with their design specifications.

As can be anticipated with a prototype system, this first quarter of continuous automatic operation disclosed some operational characteristics which could be improved with relatively minor system modification. These characteristics and the subsequent modifications are described below:

- (1) When both the chiller and the fan coils were operating simultaneously with comparable water flows (i.e., when all three fan coils are running) the cold water from the chiller bypassed the cold storage tank, and goes directly to the fan coil units. This decoupling of the cold storage tank allows the water in the cooling loop to heat up under high cooling load conditions even though there was adequate cooling capacity in the cold storage tank. To remedy this condition, an extra water return line from the evaporator to the cold storage tank was added to the system. With this modification, the cold water from the evaporator is first delivered to the storage tank and water from the storage tank is delivered to the building cooling system (e.g., full exploitation of the cold water storage tank was made by eliminating the direct flow of chiller water to the evaporator). This configuration reduces chiller peak load demands and cycling.
- (2) A spring-loaded check valve was added to the evaporator outlet to prevent the return flow from the fan coils from passing through the evaporator when the chiller is not running.
- (3) The aqueducts (flow limiting valves) in the lines to each of the fan-coil units were removed to allow the maximum flow to each unit. These valves were originally installed to maintain proper flow distribution between the three fan-coil units.
- (4) A subcooler previously installed in the R11 return line from the cooling condenser was turned on in June to improve the operation of the liquid level controller. The subcooler uses the return water to the evaporator inlet. Use of this subcooler, as well as the power loop pump inlet subcooler (described below), was evaluated in Phase I and procured in Phase II for future experimental evaluation in the field test installation. With the subcoolers, significant improvement was noted, and no further difficulty was experienced during the quarter.

- (5) A subcooler was added to the R11 return line from the power condenser to improve the pump performance. The pump performance is degraded when the returning R11 fluid is insufficiently subcooled. Previous tests had shown that at least 10 deg of subcooling is necessary; for lesser amounts of subcooling the pump performance is significantly degraded so that the pump cannot meet the flow requirement during operation at high chiller output conditions. During the preliminary testing at UTRC and the checkout and acceptance testing in Phoenix, the ambient temperature was such that there was always sufficient subcooling of the R11 return fluid. However, as summer approached and the daily temperature increased, the amount of subcooling was reduced and there were times when the pump could not keep up with the flow requirements. In order to remedy this condition, a subcooler was installed in the inlet line to the R11 pump. This subcooler uses the return water to the evaporator inlet to subcool the liquid R11, and was very effective in eliminating the pump cavitation.
- (6) The condenser fans were changed to the high angle blade set to provide greater air flow through the condenser during the hot summer months.

The above chiller modifications (4, 5, & 6) resulted in improved chiller performance during the very high ambient temperatures (105-115 F) encountered during the last week of June.

- (7) The chiller controller was reprogrammed to increase the dead band on the chiller "OFF" control signal to reduce chiller cycling during periods of low building cooling load.
- (8) With increased ambient temperature, the equipment room temperature became unbearable for operating personnel and there was some speculation that it could lead to problems with the instrumentation (DAS and controller) located in the room. Several things were done to remedy this problem. The 250-gal, hot-loop expansion tank, which is located in the equipment room, and the associated plumbing were insulated. Although the flow into this tank is small, it could become sufficiently hot to be a significant contribution to the heat load in this small equipment room. A flow deflector was installed on the evaporative cooler to provide more cool air in the region of the DAS and controller.
- (9) Collector operation caused the flex hose connections to adapt sharp ratios double bends. This condition would reduce hose life. Thus, new double walled flex hoses were installed in the water lines to the collectors. This modification reduced heat losses: as well as, increase the safety and reliability of the system.

The solar cooling system was operated only for the first two months of the quarter July 1 through September 30, 1981. During this period, the collectors and chiller ran regularly, and performance data was acquired and recorded. During the first week in August, the system was shut down briefly to readjust the R11 levels in the power and cooling loops. During the first week in September, the system operation was suspended to conserve funds. Subsequently, the turbocompressor was returned to the manufacturer (Hamilton Standard) for inspection. At that same time, the collector battery charger, Techtran data recording system and collector master control circuit board were returned to their respective manufacturers for service.

The following operations were completed during the quarter:

- (1) The DAS contact control signal was reprogrammed to provide more reliable signals to the controller. During the first four months of operation, the system was interrupted by shutdowns caused by malfunctioning control signals from the DAS. After extensive diagnostic tests of the datalogger in its operational environment, the contact control functions were reprogrammed. This change increased the reliability of the control function.
- (2) The datalogger was reprogrammed to streamline the handling of data, and an encoder was incorporated into the chiller controller to record the cause of any chiller shutdown (both normal and emergency). This minor component was a significant aide in diagnosing system malfunctions and assessing performance.
- (3) The chiller controller was reprogrammed to provide new "START" and "STOP" functions for the chiller controls. The new "START" function is similar to the original function; however, the "STOP" function is entirely new, it uses the R11 pressures rather than R11 temperatures. This function can be adjusted to assess chiller operation with various control strategies. The first strategy used in this reporting period was to allow the chiller to run over its entire operating range from compressor surge to maximum flow. The initial tests with this strategy occurred during the high ambient temperature, high load period of August and resulted in considerable chiller operation near surge conditions at low output. During operation at these (incipient surge) conditions, the chiller performed just about as well as would be expected (based on Phase I computer simulations). The chiller control strategy implemented for 1982 operation limits the chiller to moderate and high outputs, thereby reducing chiller operating time, increasing the chiller efficiency and reducing the auxiliary electricity consumption.

- (4) Electrical line filters were added to the control system power lines to prevent triggering of cooling system interlocks by various equipment switches and relays: as well as, power main voltage surges.

In 1982, the system was reactivated early in February, and operated regularly through March 11, when problems with the collector electrical power supply and control system precluded collection of solar energy and further chiller operation during the quarter through March 31, 1982. Since the system had been shut down since September 1981, all elements of the system were inspected and serviced and necessary modifications completed as noted below.

- (1) The hot storage tank top was originally insulated with a loose fiberglass blanket. Normal and sprinkler supplied ground water condensed on the inner side of the storage tank hatch covers and dripped onto the tank top causing excessive heat loss and corrosion. The tank exposed area was insulated and sealed to reduce heat losses. The hatch cover was sealed and insulated on the inner surface.
- (2) The turbocompressor heat shield was modified to adjust the labyrinth seal operating temperature. Shaft face seal and bearing coolant control subsystems were also modified.
- (3) The air-cooled condensers were refitted with low pitch blades on 3 of the 5 fans and fan controls adjusted to conserve power at low ambient temperature conditions. This arrangement appears to be appropriate for both summer and spring/fall operation.

For the quarter April 1 through June 30, 1982, in addition to the limited available solar energy due to collector control system problems, chilled water bypass through nonoperating fan/coils resulted in less than anticipated total cooling output. System and collector maintenance and repair procedures were conducted for the first three weeks of April with system operation initiated on April 22. Operation continued routinely through May but recurring collector power supply and control failures severely limited operation during June. Specifically, operation with only one collector bank operative resulted in cyclic operations and lower than expected output.

A minor operational problem was identified with the space conditioning (fan/coil) subsystem. A small amount of chilled water bypasses the cold tank and passes through the nonoperating fan/coils when the chiller is on. This flow results in a delivery of cooling to the building which is not accounted for by the instrumentation and therefore appears as a loss to the system. In addition,

this small load can maintain a high cold tank temperature during periods of low chiller output. Such conditions were encountered during this quarter at low vaporizer water temperature periods. Solenoid shutoff valves were added in each of the fan/coil water loops to prevent the cold evaporator water bypass. Operation was reinitiated in July 1 and continued through October 31, 1982.

Early in July, new chiller control algorithms were incorporated by the on-site monitor. While the ON function operated satisfactorily, the OFF function allowed improper chiller operation, thus inhibiting output. The need to overcome this and numerous other minor operational problems resulted in a site visit by a UTRC engineer in late July. All problems were successfully corrected with the exception of a turbocompressor noise/vibration indication.

Analysis of the situation resulted in removal of the machine for inspection and rebalancing at the Hamilton Standard facility in Connecticut. This process coupled with return re-installation, system recharging, and operational checks reduced running time at full capacity for July and August.

Routine operation was attained through September with substantial solar contribution to the building demand, and chiller operation with output and Coefficients Of Performance as anticipated.

While moderate running time was logged in October, data acquisition and recording problems were encountered resulting in minimal available data.

## 6.2 System Performance Summary

As indicated previously (Section 3.6.1) a realistic prediction of the solar contribution to total building cooling demand is approximately 70%. The results of a TRNSYS simulation program analysis of annual performance yielding this level of solar contribution summarized in Tables 3-14 and 3-15 can be used for comparison with measured test parameters of the field test installation.

During the first cooling season (1981) the system was operated for five months, and in 1982 nine months of operation were completed. A summary of the more significant performance parameters is provided in Table 6-1. The chiller On Time in 1981 totaled 341 hours or 82 percent of predicted operating time. In 1982 a total of 295 hours of chiller On Time was logged which is approximately 48 percent of predicted operation. This lower than anticipated On Time was the result principally, of the time required to correct collector control system problems in March and April, and to refurbish the turbocompressor in August of 1982.

Measured collector efficiencies compare reasonably well with predictions and no significant changes were noted over the two seasons of operation in spite of observed problems of minor delamination of the collector reflector surfaces during the last four months of the 1982 season. The degree of delamination observed in July 1982 was less than 2% of the surface. This delamination remained stable for the remainder of the operating season, after which necessary repairs were undertaken.

Cooling provided to the Hamilton Test Systems building is tabulated in ton-hrs on a monthly basis in Table 6-1 for both the solar system and the backup air conditioning system. While measurements of the contribution of the backup A/C are not available for the 1981 seasons, data for the 1982 season shows the solar contribution to be 54 percent, while a 70 percent contribution was anticipated. This shortfall again may be attributed to the reduced chiller On Times experienced in March and April and again in August when higher levels of cooling are demanded.

It must be noted that total measured cooling provided to the building is significantly less than originally predicted. This has been consistently observed, particularly through the 1982 cooling season. Measured values for the summer of 1981 were about half of the predicted level and for 1982 they were generally less than half the prediction. Several reasons appear to be contributing factors: 1) the weather conditions in the Phoenix area during the 1982 ten month operating period were cooler than normal requiring less cooling; 2) building occupancy was lower than assumed by the prediction program (i.e., fewer personnel and lower lighting and equipment usage result in less cooling demand);

TABLE 6-1

## FIELD TEST SYSTEM PERFORMANCE SUMMARY

|                                | 1981                       |               |               |               |                |                | 1982           |                |                |                |                |               | Totals         |                          |                     |
|--------------------------------|----------------------------|---------------|---------------|---------------|----------------|----------------|----------------|----------------|----------------|----------------|----------------|---------------|----------------|--------------------------|---------------------|
|                                | April                      | May           | June          | July          | Aug            | Feb            | March          | April          | May            | June           | July           | Aug           |                | Sept                     | Oct                 |
| <u>System Operation</u>        |                            |               |               |               |                |                |                |                |                |                |                |               |                |                          |                     |
| ● Chiller On/Up Time           | .20<br>(.23) <sup>2</sup>  | .38<br>(.305) | .50<br>(.428) | .51<br>(.480) | .58<br>(.467)  | .073<br>(.039) | .268<br>(.153) | .392<br>(.23)  | .575<br>(.305) | .240<br>(.428) | .269<br>(.480) | *<br>(.467)   | .428<br>(.403) | * <sup>1</sup><br>(.320) |                     |
| ● Chiller On Time,<br>Hrs      | 30<br>(50.6) <sup>2</sup>  | 43<br>(64.0)  | 88<br>(94.1)  | 55<br>(105.5) | 125<br>(102.7) | 13<br>(7.9)    | 10.2<br>(35.3) | 14<br>(50.6)   | 68<br>(64.0)   | 32<br>(94.1)   | 32<br>(105.5)  | 13<br>(102.7) | 78<br>(88.7)   | 34.4<br>(67.2)           | 689.4<br>(1032.9)   |
| <u>System Performance</u>      |                            |               |               |               |                |                |                |                |                |                |                |               |                |                          |                     |
| ● Collector<br>Efficiency      | .55<br>(.502) <sup>2</sup> | .46<br>(.508) | .48<br>(.532) | .38<br>(.533) | .49<br>(.517)  | .587<br>(.451) | .381<br>(.475) | .449<br>(.502) | .480<br>(.508) | .453<br>(.532) | .499<br>(.533) | *<br>(.517)   | .495<br>(.515) | *<br>(.480)              |                     |
| ● Cooling Provided,<br>Ton-Hrs |                            |               |               |               |                |                |                |                |                |                |                |               |                |                          |                     |
| Solar                          | 450                        | 568           | 678           | 330           | 1000           | 38.6           | 58.1           | 167            | 733            | 447            | 463            | 150.2         | 631            | 291                      | 2978.9 <sup>3</sup> |
| Backup A/C                     | *                          | *             | *             | *             | *              | 61.2           | 289.5          | 220            | 187            | 322            | 518            | 574.5         | 262            | 64                       | 2508.2 <sup>3</sup> |
| Total                          |                            |               |               |               |                | 99.8           | 347.6          | 387            | 920            | 769            | 981            | 724.7         | 893            | 355                      | 5487.1 <sup>3</sup> |
| ● Chiller COP                  | .56                        | .49           | .38           | .37           | .36            | .38            | .37            | .50            | .28            | .30            | .42            | *             | .41            | *                        |                     |

<sup>1</sup> \* Indicates detailed DAS data not available

<sup>2</sup> TRNSYS program predicted values which yield an annual solar contribution of 70%

<sup>3</sup> Totals for 1982 season only

3) thermostat settings selected by building occupants were generally higher than predicted (78 F or higher) again reducing the cooling demand; 4) finally, it must be recognized that the TRNSYS simulation is an imperfect model of the field test situation and may be deficient in some details whose impact is not adequately recognized.

To provide an evaluation of system performance after operating for two cooling seasons, and to illustrate the daily cycle of parameter variations, the data for a typical day (September 23, 1982) is presented in Table 6-2 and Figs. 6-1 through 6-7. A description of the terminology used in Table 6-2, the data recording methodology and parameter definitions are presented in Appendix A. It can be noted from Table 6-2 that chiller outputs as high as 16.2 tons were provided with a COP of 0.67. Comparison of the detail data of Figs. 6-4 through 6-10 with corresponding data taken during checkout and acceptance testing (Figs. 5-4 through 5-12) indicates no significant degradation of performance when operating at comparable conditions.

An overall summary of performance for the two cooling seasons is presented in Table 6-3. Total chiller On Time for two years operation in the field test is seen to be 67 percent of the predicted value and average chiller output was approximately 84% of that anticipated.

TYPICAL DAILY DATA COMPILATION

NO. DAY YEAR DATA  
9 23 1992 246

NUMBER OF SCANS = 16

RUN DATE 12100882

| TIME  | TEMP | TAIRDP | DTCL  | ETAC1 | DT/1 | TAFL  | TMVG  | TSPC  | TVEV | TVC  | PFVG  | PFEV | QAVG   | QALC   | QWOL  | TONS  | CODE |
|-------|------|--------|-------|-------|------|-------|-------|-------|------|------|-------|------|--------|--------|-------|-------|------|
| CH#M  | TEMP | TAIRDP | DTCL  | ETAC1 | DT/1 | TAFL  | TMVG  | TSPC  | TVEV | TVC  | PFVG  | PFEV | QAVG   | QALC   | QWOL  | TONS  | CODE |
| 01:00 | 75.4 | 75.4   | 11.3  | 0.00  | 0.00 | 289.1 | 178.3 | 88.9  | 72.2 | 17.7 | 11.9  | 18.5 | 0.0    | 0.0    | 20.00 | 0.000 | 0    |
| 01:00 | 76.2 | 178.3  | 7.7   | 0.25  | 0.07 | 252.2 | 257.8 | 107.7 | 55.0 | 65.2 | 171.0 | 9.5  | 2176.7 | 1370.1 | 24.57 | 13.53 | 0    |
| 01:15 | 76.0 | 178.5  | 12.5  | 0.37  | 0.05 | 263.0 | 260.9 | 107.7 | 53.6 | 65.7 | 176.3 | 8.8  | 3283.0 | 1682.1 | 24.68 | 16.27 | 0    |
| 01:15 | 76.5 | 229.5  | 12.0  | 0.45  | 0.77 | 236.5 | 232.6 | 99.1  | 53.0 | 66.1 | 166.7 | 8.6  | 2996.3 | 2616.8 | 24.68 | 15.07 | 0    |
| 01:30 | 76.4 | 178.8  | 9.8   | 0.33  | 0.06 | 252.5 | 250.7 | 107.7 | 51.2 | 65.7 | 161.9 | 8.4  | 2772.0 | 2066.5 | 24.57 | 13.93 | 0    |
| 01:30 | 76.7 | 229.7  | 12.3  | 0.32  | 0.75 | 232.3 | 230.1 | 99.7  | 51.5 | 67.2 | 157.2 | 8.2  | 2556.7 | 2263.8 | 24.68 | 12.81 | 0    |
| 01:45 | 76.7 | 229.7  | 12.4  | 0.35  | 0.72 | 245.7 | 245.3 | 107.7 | 50.7 | 67.8 | 156.9 | 8.0  | 2330.0 | 2372.5 | 24.57 | 11.64 | 0    |
| 01:45 | 76.9 | 229.7  | 12.5  | 0.39  | 0.13 | 242.6 | 231.7 | 99.7  | 50.7 | 67.8 | 156.9 | 8.0  | 4637.0 | 2436.6 | 24.57 | 11.64 | 0    |
| 02:00 | 76.1 | 229.7  | 12.5  | 0.36  | 0.73 | 240.7 | 240.1 | 107.7 | 49.6 | 67.5 | 151.5 | 7.9  | 3185.4 | 2309.0 | 24.68 | 10.77 | 0    |
| 02:00 | 76.5 | 197.3  | 11.3  | 0.45  | 0.74 | 249.4 | 241.2 | 107.7 | 48.0 | 67.8 | 147.1 | 8.0  | 2030.9 | 2266.7 | 24.79 | 10.22 | 0    |
| 02:00 | 76.7 | 229.7  | 12.9  | 0.19  | 0.69 | 245.8 | 246.3 | 106.4 | 48.4 | 68.1 | 146.2 | 8.5  | 2180.9 | 2395.4 | 24.79 | 10.97 | 0    |
| 02:15 | 76.2 | 229.5  | 12.1  | 0.33  | 0.09 | 243.3 | 238.2 | 107.7 | 48.4 | 67.6 | 142.0 | 8.7  | 1883.2 | 2389.7 | 24.68 | 9.89  | 0    |
| 02:15 | 76.6 | 229.5  | 12.0  | 0.17  | 0.67 | 241.7 | 236.7 | 106.7 | 48.0 | 68.2 | 141.0 | 8.6  | 1927.6 | 2388.9 | 24.68 | 9.50  | 0    |
| 02:15 | 76.3 | 229.7  | 12.2  | 0.13  | 0.74 | 237.4 | 235.4 | 107.7 | 48.0 | 68.2 | 141.0 | 8.6  | 3751.1 | 1905.0 | 24.68 | 21.42 | 0    |
| 02:30 | 76.3 | 229.7  | 12.2  | 0.13  | 0.74 | 237.4 | 235.4 | 107.7 | 48.0 | 68.2 | 141.0 | 8.6  | 1627.3 | 2343.6 | 24.68 | 8.11  | 0    |
| 02:30 | 76.3 | 229.7  | 12.2  | 0.13  | 0.74 | 237.4 | 235.4 | 107.7 | 48.0 | 68.2 | 141.0 | 8.6  | 3665.8 | 2343.6 | 24.68 | 8.11  | 0    |
| 02:45 | 76.3 | 229.7  | 12.2  | 0.13  | 0.74 | 237.4 | 235.4 | 107.7 | 48.0 | 68.2 | 141.0 | 8.6  | 1811.4 | 2303.0 | 24.68 | 8.11  | 0    |
| 02:45 | 76.3 | 229.7  | 12.2  | 0.13  | 0.74 | 237.4 | 235.4 | 107.7 | 48.0 | 68.2 | 141.0 | 8.6  | 3581.9 | 2303.0 | 24.68 | 8.11  | 0    |
| 02:57 | 76.1 | 229.7  | 12.7  | 0.77  | 0.77 | 242.1 | 240.0 | 107.7 | 48.1 | 68.1 | 141.0 | 8.6  | 1173.9 | 2093.0 | 24.68 | 9.25  | 11   |
| 03:00 | 76.6 | 229.7  | 12.9  | 0.66  | 0.66 | 245.8 | 244.1 | 107.7 | 48.1 | 68.1 | 141.0 | 8.6  | 2186.7 | 2137.0 | 24.68 | 0.000 | 11   |
| 03:00 | 76.5 | 229.7  | 12.9  | 0.60  | 0.66 | 247.9 | 246.6 | 107.7 | 48.1 | 68.1 | 141.0 | 8.6  | 2255.7 | 2137.0 | 24.68 | 0.000 | 11   |
| 03:15 | 76.5 | 229.7  | 13.0  | 0.16  | 0.67 | 247.6 | 247.3 | 106.4 | 48.1 | 68.1 | 139.6 | 8.6  | 2286.1 | 2137.0 | 24.68 | 0.000 | 11   |
| 03:15 | 76.7 | 229.7  | 13.0  | 0.07  | 0.67 | 247.6 | 247.3 | 106.4 | 48.1 | 68.1 | 139.6 | 8.6  | 659.4  | 33.00  | 24.68 | 0.000 | 11   |
| 03:30 | 76.3 | 229.5  | 12.2  | 0.16  | 0.66 | 248.1 | 247.9 | 105.7 | 48.1 | 68.1 | 140.8 | 8.6  | 2213.4 | 2137.0 | 24.68 | 0.000 | 11   |
| 03:30 | 76.7 | 229.5  | 12.9  | 0.23  | 0.66 | 249.0 | 249.7 | 105.7 | 48.1 | 68.1 | 140.8 | 8.6  | 2351.0 | 2137.0 | 24.68 | 0.000 | 11   |
| 03:45 | 76.3 | 229.5  | 12.3  | 0.23  | 0.66 | 249.7 | 249.6 | 106.7 | 48.1 | 68.1 | 140.8 | 8.6  | 2401.5 | 2137.0 | 24.68 | 0.000 | 11   |
| 03:45 | 76.3 | 229.5  | 12.3  | 0.18  | 0.66 | 251.1 | 250.2 | 106.7 | 48.1 | 68.1 | 140.8 | 8.6  | 2369.3 | 2137.0 | 24.68 | 0.000 | 11   |
| 04:00 | 76.3 | 229.7  | 12.3  | 0.13  | 0.66 | 257.3 | 256.7 | 107.7 | 48.1 | 68.1 | 140.8 | 8.6  | 2232.8 | 2137.0 | 24.68 | 0.000 | 11   |
| 04:00 | 76.5 | 229.5  | 12.9  | 0.92  | 0.69 | 252.3 | 262.2 | 106.7 | 48.1 | 68.1 | 140.8 | 8.6  | 2360.8 | 2137.0 | 24.68 | 0.000 | 11   |
| 04:00 | 76.5 | 229.5  | 12.9  | 0.91  | 0.69 | 252.3 | 262.2 | 106.7 | 48.1 | 68.1 | 140.8 | 8.6  | 2360.8 | 2137.0 | 24.68 | 0.000 | 11   |
| 04:15 | 76.5 | 229.7  | 12.2  | 0.15  | 0.70 | 249.7 | 249.3 | 106.7 | 48.1 | 68.1 | 140.8 | 8.6  | 2367.5 | 2137.0 | 24.68 | 0.000 | 11   |
| 04:15 | 76.5 | 229.7  | 12.2  | 0.15  | 0.70 | 249.7 | 249.3 | 106.7 | 48.1 | 68.1 | 140.8 | 8.6  | 2367.5 | 2137.0 | 24.68 | 0.000 | 11   |
| 04:30 | 76.6 | 229.5  | 12.3  | 0.41  | 0.71 | 249.0 | 248.9 | 107.7 | 48.1 | 68.1 | 140.8 | 8.6  | 1335.2 | 2384.3 | 24.68 | 9.01  | 11   |
| 04:30 | 76.6 | 229.5  | 12.3  | 0.41  | 0.71 | 249.0 | 248.9 | 107.7 | 48.1 | 68.1 | 140.8 | 8.6  | 3190.3 | 2384.3 | 24.68 | 9.01  | 11   |
| 05:00 | 76.4 | 243.0  | 12.6  | 0.92  | 0.63 | 257.7 | 252.5 | 116.7 | 48.1 | 68.1 | 142.7 | 8.8  | 1871.0 | 2784.8 | 24.68 | 9.43  | 11   |
| 05:00 | 76.4 | 243.0  | 12.6  | 0.92  | 0.63 | 257.7 | 252.5 | 116.7 | 48.1 | 68.1 | 142.7 | 8.8  | 4185.1 | 2784.8 | 24.68 | 9.43  | 11   |
| 05:15 | 76.7 | 229.5  | 12.3  | 0.21  | 0.72 | 248.7 | 248.7 | 105.7 | 48.1 | 68.1 | 141.0 | 8.6  | 1760.1 | 2464.0 | 24.68 | 8.81  | 11   |
| 05:15 | 76.7 | 229.5  | 12.3  | 0.21  | 0.72 | 248.7 | 248.7 | 105.7 | 48.1 | 68.1 | 141.0 | 8.6  | 4186.6 | 2464.0 | 24.68 | 8.81  | 11   |
| 05:30 | 76.6 | 229.7  | 12.3  | 0.32  | 0.70 | 252.7 | 249.2 | 112.7 | 48.1 | 68.1 | 140.8 | 8.6  | 1627.7 | 2452.0 | 24.68 | 8.11  | 11   |
| 05:30 | 76.6 | 229.7  | 12.3  | 0.32  | 0.70 | 252.7 | 249.2 | 112.7 | 48.1 | 68.1 | 140.8 | 8.6  | 4054.3 | 2452.0 | 24.68 | 8.11  | 11   |
| 05:45 | 76.3 | 229.5  | 12.6  | 0.15  | 0.72 | 249.7 | 249.9 | 112.7 | 48.1 | 68.1 | 140.8 | 8.6  | 1480.9 | 2286.6 | 24.68 | 7.67  | 11   |
| 05:45 | 76.3 | 229.5  | 12.6  | 0.15  | 0.72 | 249.7 | 249.9 | 112.7 | 48.1 | 68.1 | 140.8 | 8.6  | 4002.1 | 2286.6 | 24.68 | 7.67  | 11   |
| 06:15 | 76.9 | 178.9  | 9.4   | 0.72  | 0.75 | 245.8 | 243.1 | 116.7 | 48.1 | 68.1 | 142.7 | 8.5  | 1366.9 | 2064.7 | 24.68 | 6.83  | 11   |
| 06:15 | 76.9 | 178.9  | 9.4   | 0.72  | 0.75 | 245.8 | 243.1 | 116.7 | 48.1 | 68.1 | 142.7 | 8.5  | 3671.5 | 2064.7 | 24.68 | 6.83  | 11   |
| 06:30 | 76.2 | 178.7  | 12.0  | 0.00  | 0.79 | 249.1 | 248.6 | 107.7 | 48.1 | 68.1 | 140.8 | 8.6  | 1667.0 | 2137.0 | 24.68 | 0.000 | 10   |
| 06:30 | 76.2 | 178.7  | 12.0  | 0.00  | 0.79 | 249.1 | 248.6 | 107.7 | 48.1 | 68.1 | 140.8 | 8.6  | 443.5  | 2137.0 | 24.68 | 0.000 | 10   |
| 06:45 | 76.6 | 178.6  | 12.1  | 0.69  | 0.71 | 245.8 | 245.1 | 107.7 | 48.1 | 68.1 | 140.8 | 8.6  | 1727.1 | 2137.0 | 24.68 | 0.000 | 10   |
| 06:45 | 76.6 | 178.6  | 12.1  | 0.69  | 0.71 | 245.8 | 245.1 | 107.7 | 48.1 | 68.1 | 140.8 | 8.6  | 455.2  | 2137.0 | 24.68 | 0.000 | 10   |
| 07:00 | 76.7 | 178.9  | 9.4   | 0.95  | 0.89 | 248.7 | 246.3 | 106.4 | 48.1 | 68.1 | 140.8 | 8.6  | 1354.6 | 2137.0 | 24.68 | 0.000 | 10   |
| 07:00 | 76.7 | 178.9  | 9.4   | 0.95  | 0.89 | 248.7 | 246.3 | 106.4 | 48.1 | 68.1 | 140.8 | 8.6  | 455.2  | 2137.0 | 24.68 | 0.000 | 10   |
| 07:15 | 76.0 | 150.0  | 7.0   | 0.33  | 0.76 | 242.4 | 242.1 | 105.7 | 48.1 | 68.1 | 142.7 | 8.5  | 609.8  | 0.00   | 24.68 | 0.000 | 0    |
| 07:15 | 76.0 | 150.0  | 7.0   | 0.33  | 0.76 | 242.4 | 242.1 | 105.7 | 48.1 | 68.1 | 142.7 | 8.5  | 609.8  | 0.00   | 24.68 | 0.000 | 0    |
| 07:30 | 76.1 | 71.1   | -10.6 | 0.05  | 1.12 | 186.5 | 229.9 | 80.7  | 76.8 | 57.8 | 122.5 | 15.5 | 0.00   | 0.00   | 24.68 | 0.000 | 0    |
| 07:30 | 76.1 | 71.1   | -10.6 | 0.05  | 1.12 | 186.5 | 229.9 | 80.7  | 76.8 | 57.8 | 122.5 | 15.5 | 0.00   | 0.00   | 24.68 | 0.000 | 0    |

DAILY

NO. DAY YEAR DATA  
9 23 1992 246

| CHILL | SYSTEM | ETAC1 | ETAC7  | DESH  | CICL  | CCOLL | CYCLEM | OMLCS | QVAP | GFCCOL | OCLOSS | COP  | EEP  | TONS | BUEC |
|-------|--------|-------|--------|-------|-------|-------|--------|-------|------|--------|--------|------|------|------|------|
| 4.738 | 7.284  | 0.725 | 0.5101 | 240.3 | 2.236 | 1.107 | 1.172  | 0.34  | 0.93 | 0.992  | 0.2671 | 0.51 | 16.5 | 10.4 | 6.6  |

\*\*\*\*\* CALCULATIONS PERFORMED BY SDR REALL \*\*\*\*\*

### UTRC SOLERAS INSTALLATION

SEPT. 23, 1982 TEST DATA

INSOLATION

○ IADIR

□ IANOR

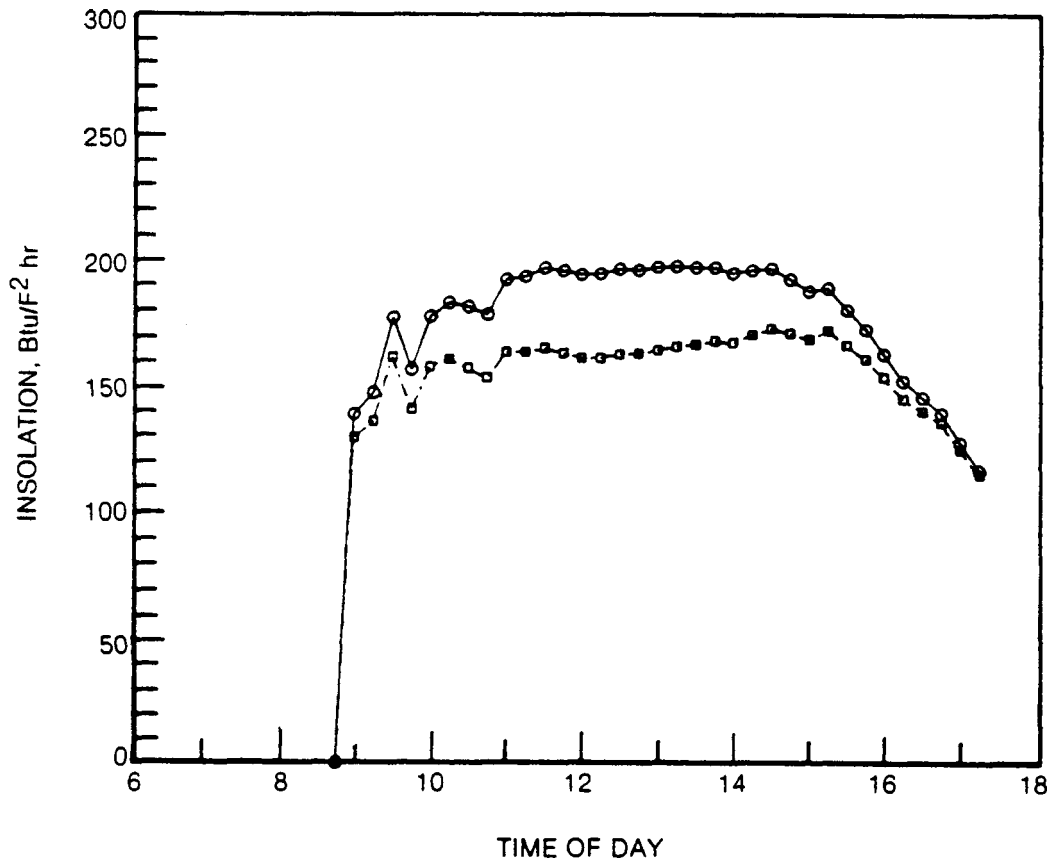

### UTRC SOLERAS INSTALLATION

SEPT. 23, 1982 TEST DATA  
COLLECTOR EFFICIENCY

○ ETAC1  
□ ETAC2

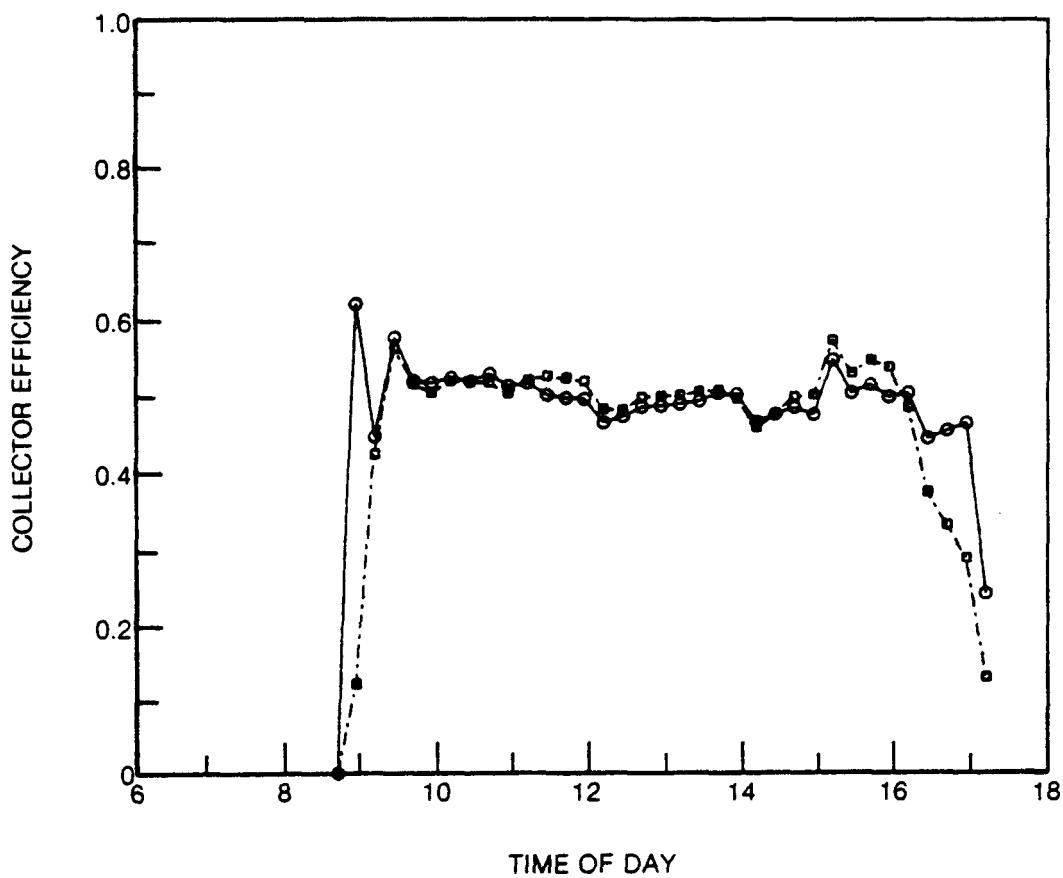

### UTRC SOLERAS INSTALLATION

SEPT. 23, 1982 TEST DATA  
POWER LOOP TEMPERATURES

- TFGV
- TAMB
- + TWVG
- ◇ TSPC

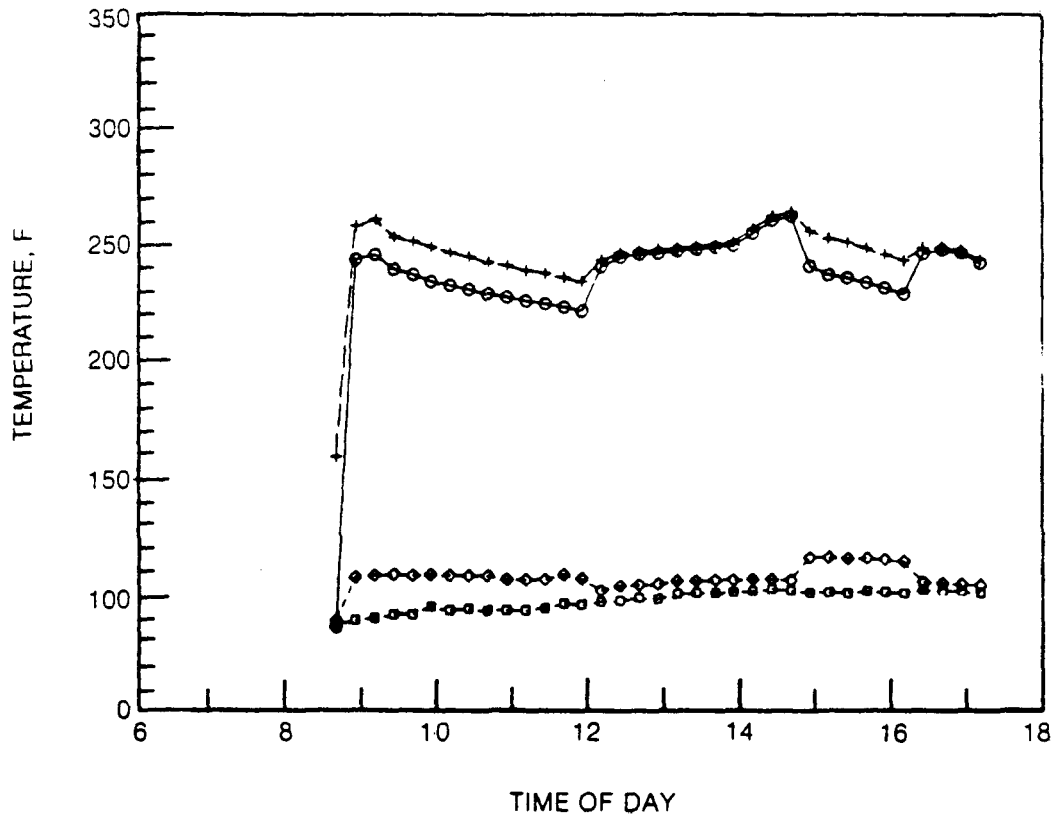

### UTRC SOLERAS INSTALLATION

SEPT. 23, 1982 TEST DATA

COOLING LOOP TEMPERATURES

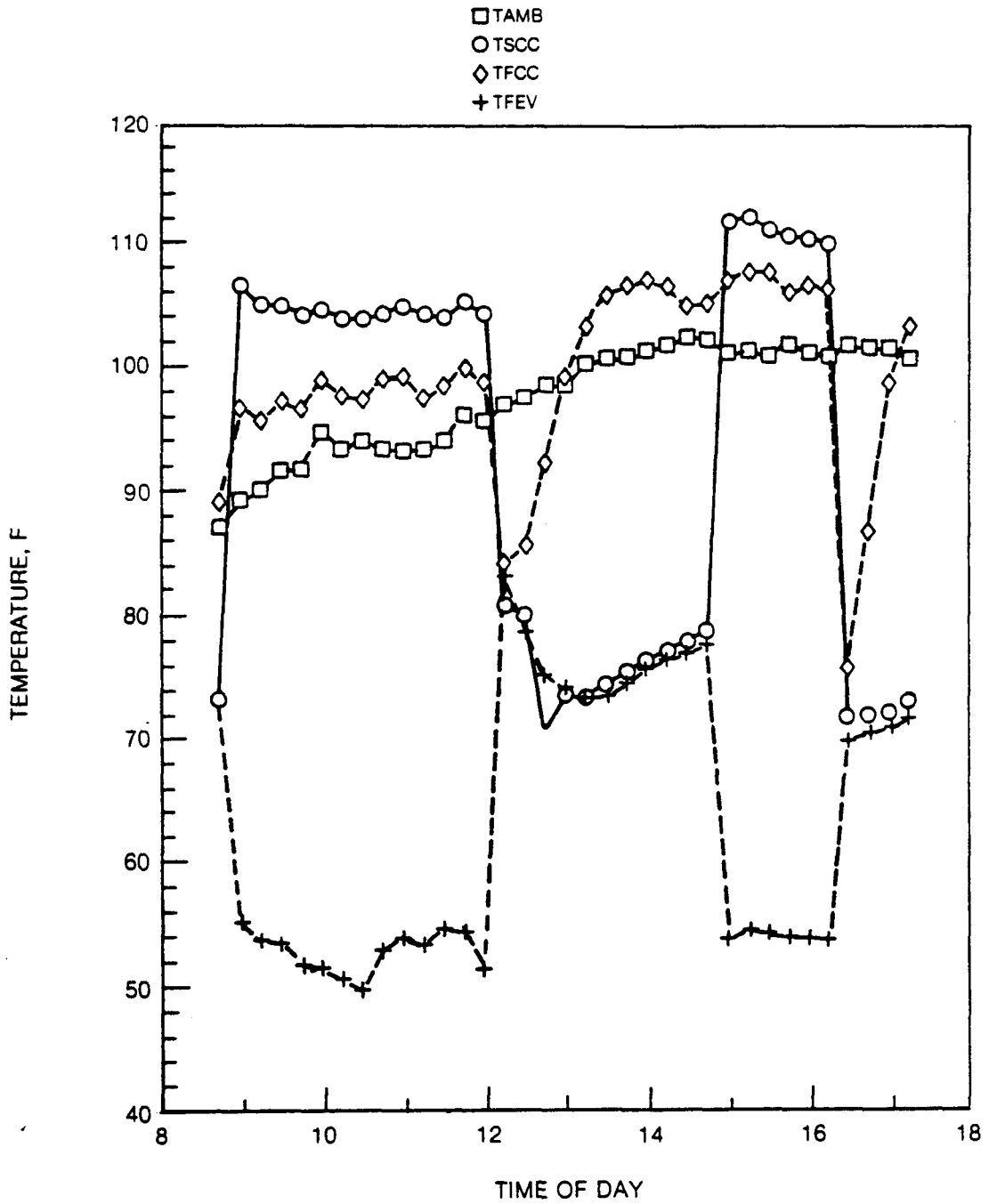

### UTRC SOLERAS INSTALLATION

SEPT. 23, 1982 TEST DATA  
CHILLER PERFORMANCE

○ TONS  
× COP

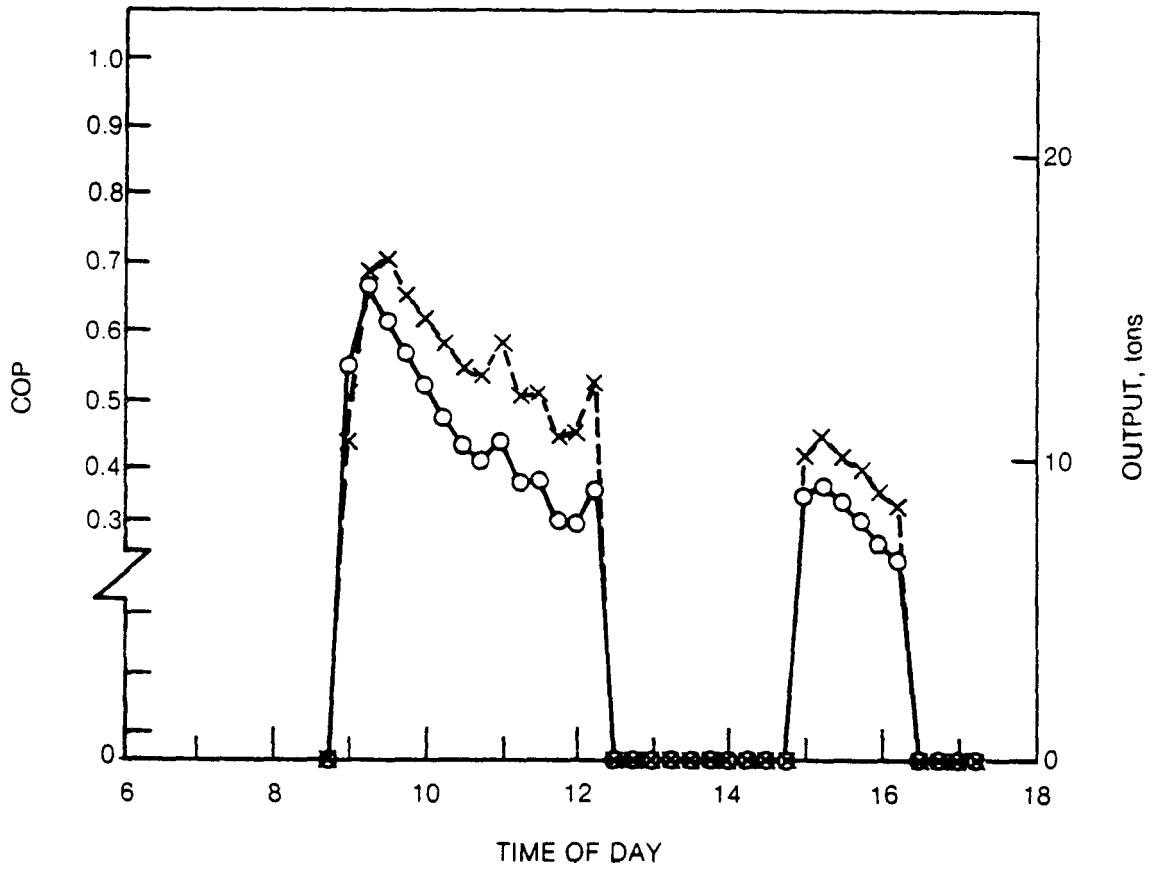

### SOLAR COOLING SYSTEM TYPICAL TEST DATA

DATE: 9/23/82  
COOLING CONDENSER  $T_{SAT} = 96 - 108$  F

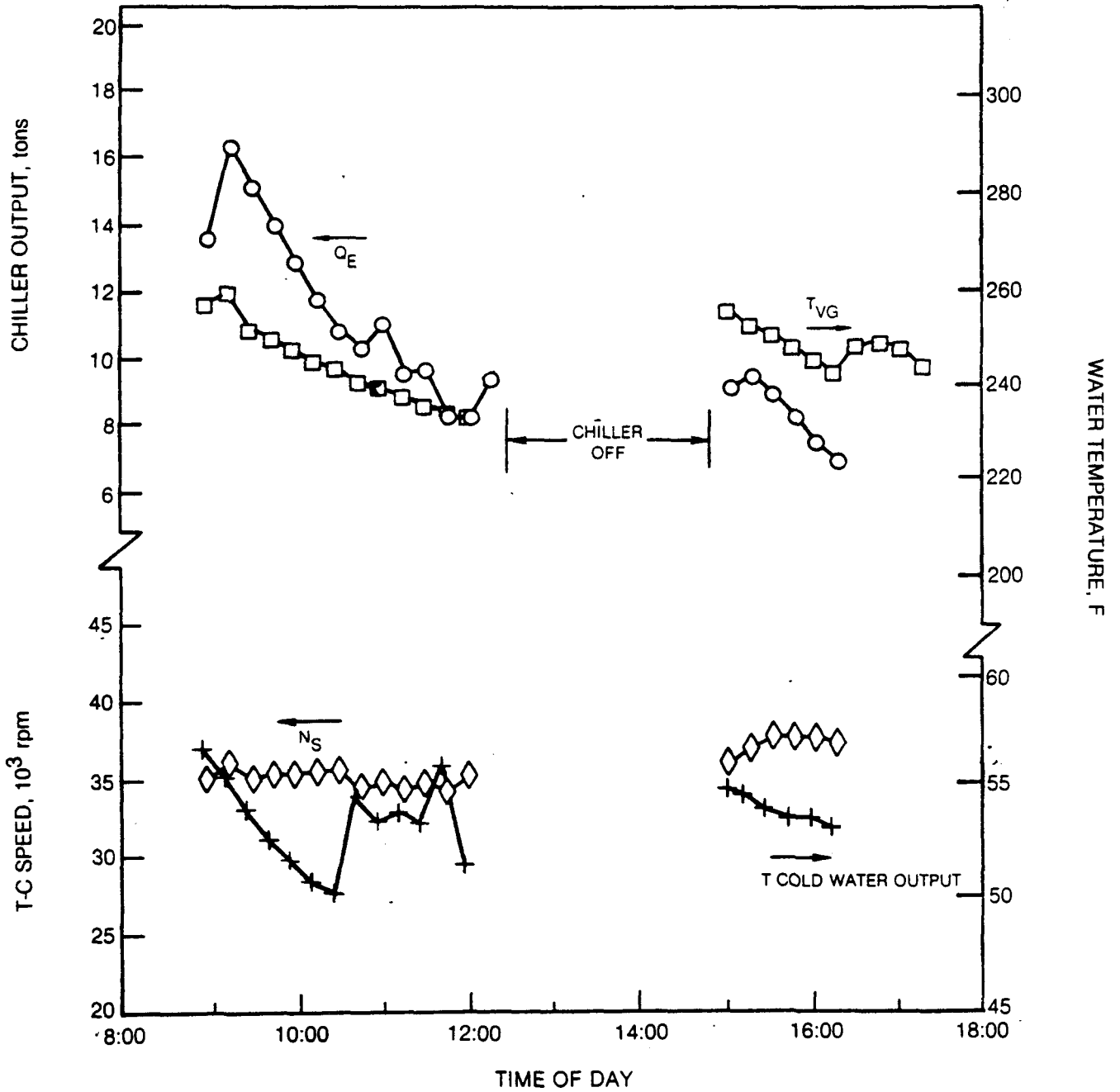

### SOLAR COOLING SYSTEM TYPICAL TEST PERFORMANCE

DATE: 9/23/82

CONDENSER SATURATION TEMP = 96 - 108 F

○ CHILLER  
□ FAN COILS

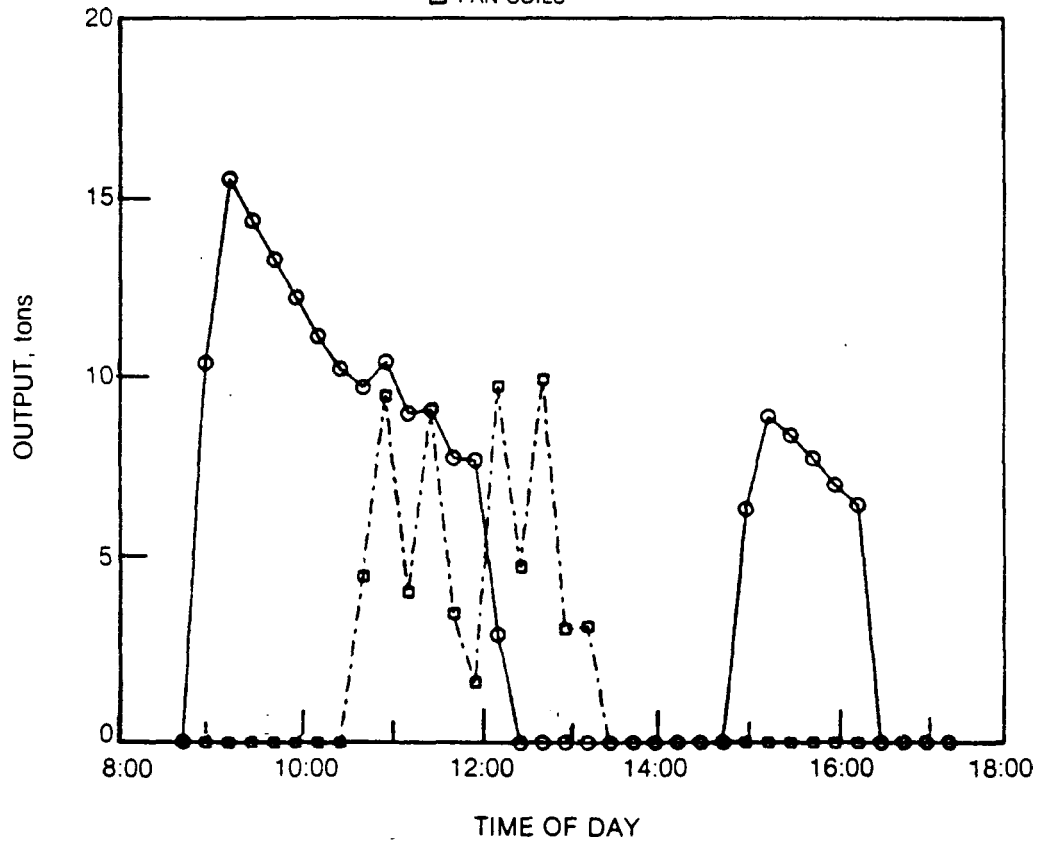

TABLE 6-3

## UTRC SOLERAS SOLAR COOLING SYSTEM

Performance Summary for Period March 31, 1981 to October 31, 1982

| <u>System Operation</u>        | <u>Measured (Calculated)</u> |          |
|--------------------------------|------------------------------|----------|
| ● Chiller ON/UP Time           | 0.227                        | (0.340)  |
| ● Chiller On Time              | 689.4                        | (1032.9) |
| <br><u>System Performance</u>  |                              |          |
| ● Collector Efficiency         | 0.475                        | (0.508)  |
| ● Chiller COP                  | 0.393                        | (0.523)  |
| ● Chiller Output, Average Tons | 9.45                         | (11.32)  |

### 6.3 Reliability and Maintainability Summary

An extensive reliability and maintainability analysis of the field test system installation was conducted as discussed in the Phase I and II Topical Report, (UTRC report R82-955027-1). Included in this effort was an assessment of both the development prototype solar cooling system and an eventual commercial system installation. An indication of the number of probable failures of the prototype system installation to be expected with operating times as predicted by the TRNSYS computer analysis of system annual performance was provided.

Failure mode and effects analyses, were also completed for the solar collector/storage and chiller subsystems to identify failures which could result in hazardous conditions and to provide appropriate means for eliminating such hazards, thereby insuring safe system operation. An allied effort was preparation of an Operating and Maintenance Manual for use in the field test program. This manual was published (UTRC report R81-955023-1) and periodically revised as system changes were made or operating procedures revised as more experience was gained.

As indicated in Appendix C of UTRC report R82-955027-1, the reliability analysis considered the prototype system as three (3) modules as shown in Figure C-1 of Ref. 4). Included were the collector/storage module, the chiller module, and the distribution module. Total system reliability predictions considered the combination of the reliabilities of these three modules with the appropriate anticipated operating time for each module.

An additional subsystem (module) which was not included in this assessment is the Data Acquisition System (DAS). While it is entirely proper to consider that a completely independent DAS has no effect on the operating system reliability, the installed field test Data Acquisition System is not truly independent; and, in fact, has a very pervasive influence on system operation. Several functions which control operation of the chiller module and the distribution module are either generated by the DAS or use signals which are processed by the DAS. For this reason total system reliability for the installed field test prototype system is dependent on the reliability of all four modules.

As previously noted, the field test prototype system has been functioning for two cooling systems accumulating approximately 1400 hours operating time. While operating times of the subsystems has been less than anticipated by the initial analysis, the field test has provided much valuable information and experience which can be utilized in subsequent system design activities.

Table 6-4 includes a summary account of system operating experience and provide a listing of significant failures encountered and difficulties noted, with suggested approaches for improving reliability in the design and operation of future solar cooling systems. A full and detailed account and discussion of system operation each month of the two cooling seasons has been provided by the monthly progress reports (UTRC reports R80-955013-15 thru-34).

Entries provides in Table 6-4 are assigned to the appropriate module defined for purposes of a reliability assessment. These modules include those of Fig. C-1 of Ref. 1 and the DAS module. Each module event listing is arranged in general chronological order. A separate tabulation is provided for each cooling season.

Examination of the number of failure occurrences listed in Table 6-4 leads to the obvious conclusion that the reliability attained by the field test system was significantly below that predicted (even with consideration of the additional DAS module). A major contributor to this result appears to be mis-application of components to the particular subsystem. Such occurrences would be prevented in commercial systems by more extensive engineering design and development, which was beyond the scope of this prototype field tests program. For example, the numerous collector control failures should be elminated with moderate development effort and increased production experience. Simple standard component failures caused by mis-application such as solenoid valves and RTD's have already been substantially reduced. The number of wear related or corrosion failures were predicably very small.

TABLE 6-4

## EVENT SUMMARY

| <u>Year</u> | <u>Collector/Storage Module</u>                                                                                      | <u>Chiller Module</u>                                                                                                                                                                                   | <u>Distribution Module</u>                                                                                                        | <u>DAS Module</u>                                                                                  |
|-------------|----------------------------------------------------------------------------------------------------------------------|---------------------------------------------------------------------------------------------------------------------------------------------------------------------------------------------------------|-----------------------------------------------------------------------------------------------------------------------------------|----------------------------------------------------------------------------------------------------|
| 1981        | Collector limit and overtravel switches replaced with improved model.                                                | Sporadic cavitation of R11 pump observed.                                                                                                                                                               | Plumbing changed to add separate line to cold tank.                                                                               | Data logger recording of instantaneous and averaged data on single scan observed to be unreliable. |
|             | Expansion tank and lines insulated to reduce heat loss.                                                              | Subcooler installed in R11 pump inlet line to prevent cavitation.                                                                                                                                       | Check valve in evaporator outlet water line replaced with spring loaded closed model to prevent flow bypass.                      | New components installed. <sup>1</sup>                                                             |
|             | Collector limit and overtravel switches again replaced with more rugged model.                                       | High pitch fan blades installed in condensers to increase cooling at high ambient temperatures.                                                                                                         | Center zone Aquaduct removed from Fan/coil #1 water line to allow full flow.                                                      | Contact closure output and analog circuit boards defective and replaced. <sup>1</sup>              |
|             | Collector water loop flow switch malfunctioned and replaced <sup>2*</sup>                                            | Turbocompressor expansion valve cleaned. Intermittent flow interruption noted.                                                                                                                          | Aquaduct removed from fan/coil #3 water line to provide maximum available flow.                                                   | Sporadic interruption of contract closure output signals induced chiller shutdowns. <sup>1</sup>   |
|             | Hot water loop makeup water pump failed and replaced. Original motor undersized. <sup>1</sup>                        | Power loop R11 tested for free chlorine. None detected.                                                                                                                                                 | Fan/coil water pump coupling slipping. Improperly tightened. Corrected. <sup>1</sup>                                              | Shutdown code recorder added to Modicom.                                                           |
|             | Expansion tank pressure transducer failed and replaced. Damaged by power line transients. <sup>2</sup>               | Bearing cooling flow solenoid valve failed, interrupting flow and inducing T/C shutdown due to seal over-temperature. Tip of valve poppet broke off and plugged flow path. Valve replaced. <sup>1</sup> | Electrical power failure to fan/coils and room thermostats. Fuse blown due to parallel non-air-conditioning electrical equipment. | DAS reprogrammed to change relay contact closure mode.                                             |
|             | Hot storage tank instrumentation wiring deterioration noted in hot/moist environment.                                |                                                                                                                                                                                                         |                                                                                                                                   | Chiller START and STOP algorithms incorporated, using pressure signals rather than temperature.    |
|             | RTD's malfunctioned and replaced. <sup>2</sup>                                                                       |                                                                                                                                                                                                         |                                                                                                                                   |                                                                                                    |
|             | West collector local controller defective and replaced. <sup>2</sup>                                                 | Bearing cooling fluid accumulator leak repaired.                                                                                                                                                        |                                                                                                                                   |                                                                                                    |
|             | Battery charger defective and replaced. <sup>1</sup>                                                                 |                                                                                                                                                                                                         |                                                                                                                                   |                                                                                                    |
|             | West collector row limit switches replaced. Separation between limit and overtravel switches increased. <sup>1</sup> |                                                                                                                                                                                                         |                                                                                                                                   |                                                                                                    |

\* Number of failure occurrences

TABLE 6-4 (Cont'd)

## EVENT SUMMARY

| <u>Year</u> | <u>Collector/Storage Module</u>                                                                                                                                                                                                                                                                                                                                                                                                                                                                                                                                                                                                                                                                                                                                                                                                                                                                                                                                                                                                                                                                                                                                                                                                                                                    | <u>Chiller Module</u>                                                                                                                                                                                                                                                                                                                                                                                                                                                                                                                                                                                                                                                                                                                                                                                                                                                                                        | <u>Distribution Module</u>                                                                                                                                                                                | <u>DAS Module</u>                                                                                                                                                                                                                                                                                                                                                                                                                                                                                                     |
|-------------|------------------------------------------------------------------------------------------------------------------------------------------------------------------------------------------------------------------------------------------------------------------------------------------------------------------------------------------------------------------------------------------------------------------------------------------------------------------------------------------------------------------------------------------------------------------------------------------------------------------------------------------------------------------------------------------------------------------------------------------------------------------------------------------------------------------------------------------------------------------------------------------------------------------------------------------------------------------------------------------------------------------------------------------------------------------------------------------------------------------------------------------------------------------------------------------------------------------------------------------------------------------------------------|--------------------------------------------------------------------------------------------------------------------------------------------------------------------------------------------------------------------------------------------------------------------------------------------------------------------------------------------------------------------------------------------------------------------------------------------------------------------------------------------------------------------------------------------------------------------------------------------------------------------------------------------------------------------------------------------------------------------------------------------------------------------------------------------------------------------------------------------------------------------------------------------------------------|-----------------------------------------------------------------------------------------------------------------------------------------------------------------------------------------------------------|-----------------------------------------------------------------------------------------------------------------------------------------------------------------------------------------------------------------------------------------------------------------------------------------------------------------------------------------------------------------------------------------------------------------------------------------------------------------------------------------------------------------------|
| 1982        | Collector master controller circuit board defective. Replaced. <sup>1</sup><br>Abnormally high battery charger current noted.<br>Hot storage tank demand thermocouple and RTD failed. Replaced. <sup>2</sup><br>Hatch cover insulated and sealed.<br>Hot tank exposed top cleaned, insulated and sealed to prevent corrosion and heat loss.<br>Batteries replaced with heavy duty type.<br>Battery charger and collector local controller diodes failed and replaced. <sup>2</sup><br>Collector water loop flow switch defective, replaced by reed type. <sup>1</sup><br>Local controlled power transistors failed. Circuit boards replaced. <sup>2</sup><br>Collector water loop flow switch erratic operation. Repaired and cleaned. <sup>1</sup><br>West bank local controller power transistors failed. <sup>1</sup> Apparent overload due to cycling with erratic flow switch signals. <sup>1</sup><br>Flow switch failed. Replaced by differential pressure switch. Failure due to continuous exposure to high temperatures.<br>Collector reflective surface delaminations noted. Negligible performance impact.<br>Collector local controller board defective. EPROM integrated circuits replaced. <sup>1</sup><br>Collector reflective surface delaminated areas repaired. | Turbocompressor heat shield modified to adjust inboard lead seal temperature. New shaft face seal installed with higher spring force. Lower capacity (1/4 ton) expansion valve installed in bearing feed system.<br><br>Condenser fan blade changed. Installed 3 low pitch and 2 high pitch blades on each condenser. Low pitch fans operate at low ambient temperature for power reduction.<br><br>Bearing cooling expansion valve clogged, interrupting flow. Subsequently cleared itself. <sup>1</sup><br><br>Compressor outlet flange leaked. Corrected by tightening bolts. Fluid loss replaced. <sup>1</sup><br><br>Turbocompressor abnormal noise and vibration noted. T/C removed for service and balancing. Reinstalled. <sup>1</sup><br><br>Power loop blowout disc ruptured. Rll charge lost. Disc failed due to corrosion. No excessive overpressure occurred. Disc not needed and not replaced. | Evaporator chilled water bypass through non-operating fan/coils noted.<br><br>Solenoid shut-off valve incorporated in each fan/coil water line to preclude chilled water bypass with fan/coil turned off. | Modicon reprogrammed to limit chiller operation to high output/high performance regime.<br><br>Modicon program revised to change manual start sequence/bearing pump controlled by accumulator pressure/time delays revised and some deleted.<br><br>Cassette data recorder failed and repaired. <sup>2</sup><br><br>New chiller START/STOP algorithms incorporated. Simpler function using fewer inputs.<br><br>Human error in programming caused T/C cycling with approximately 2 minute frequency. Error corrected. |

#### 6.4 Summary and Recommendations

The objective of the Solar Cooling Engineering Field Tests is to bring solar cooling one step closer to commercialization on a competitive basis with conventional cooling systems. To meet this objective, modifications were made to the system developed under the National Solar cooling Program, advancing overall system performances, while at the same time lowering system design, installation, and maintenance costs.

United Technologies Research Center has installed an 18-ton (60 kW) air-cooled Rankine cycle unit at the Hamilton Test Systems Office in Phoenix, Arizona. This building is a energy efficient passively cooled single story structure which employs extensive overhangs and greenery for external shading. Powered by 1300 ft<sup>2</sup> of tracking parabolic trough collectors the solar cooling chiller provides 70 percent of the building's cooling requirements. Other features of the system are (1) the use of thermal storage consisting of a 2000 gallon cold water tank and a 1500 gallon hot water tank, (2) space conditioning with three fan-coil units and (3) the use of microcomputers for control of the collector storage, chiller and data acquisition systems.

Engineering field testing of the UTC SOLERAS prototype solar cooling system was terminated at the end of October, 1982 after operation for two cooling seasons. Major elements of the chiller module had been previously operated for extended periods of time in the UTRC laboratories. Operation of this one-of-a-kind system in the field test environment had demonstrated its performance potential and provided invaluable experience applicable to design and operation of future installations.

Design of the solar cooling system to meet the specific load profile requirements of the HTS office resulted in the use of a minimum amount of solar collector (~ 75 ft<sup>2</sup>/ton) and allowed optimal exploitation of the buildings' passive cooling features. Specifically, more of the solar energy available on weekends, mornings and other low load periods; as well as, energy available at low insolation levels is collected, stored and utilized during peak load periods. In addition, the use of a water chiller configuration with both hot and cold storage tanks provides a very flexible design which can be easily (1) increased in capacity by the addition of collector area and more fan-coil units; and (2) adapted to meet heating loads (space or domestic hot water) by the simple addition of one heat exchanger.

The UTC solar system met its design projection for instantaneous performance (COP, output tonnage and EER) and integrated performance (solar contribution) during all weather and load conditions encountered. Annual performance measures were reduced due primarily to various collector and data-logger controller malfunctions. Clearly, the prototype nature of this first unit resulted in more than normal shutdowns for system adjustments and maintenance. Accordingly, many of the long term implications of the design have not been fully evaluated and will require further testing. Specifically, evaluations have not been conducted for various system modifications such as insulation and water proofing of the storage tank top, installation of solenoid valves in each fan-coil supply line and collector control changes.

It is recommended that the system control be modified to function without the data acquisition system and the system be operated and evaluated for a third cooling season.

REFERENCES

1. Biancardi, F. R., et al: Design, Development and Testing of a Solar-Powered Multi-Family Residential Prototype Turbocompressor Heat Pump. UTRC Report No. R79-953050-1, 1979.
2. SOLERAS Program, Engineering Test of a Solar Cooling System, Operating & Maintenance Manual. UTRC Report No. R81-955023-1, March 1982.
3. SOLERAS Program, Engineering Test of a Solar Cooling System, Final Engineering and Manufacturing Documentation. UTRC Report No. R80-955013-7, July 1980.
4. SOLERAS Program, Phase I and II Topical Report, UTRC Report No. R81-955027-1, June 1982.

Blank Page

## APPENDIX A

## DATALOGGER DATA PROCESSING RELATIONSHIPS

This appendix describes the specific relationships used to define the performance of the solar cooling system and its major subsystems. Performance is assessed for 15-minute, daily, weekly and monthly periods of time. An Autodata Ten/5 converts instrumentation sensor signals to engineering units and calculates and records the various performance parameters for each 15-minute period. These data, recorded on magnetic tape, are sent back to UTRC where the daily, weekly and monthly summaries are prepared. In addition, the format and typical performance results are presented.

Input signals from the 35 sensors are scanned every minute and outputs provided and recorded at the end of each 15-minute time period. Instantaneous final readings are converted to appropriate engineering units for recording. Critical performance parameters are determined based on the average of all scans for the 15-minute time period. The following relationships define these performance parameters.

Average Solar Insolation - IADR

$$\text{Average Solar Insolation} = \frac{\text{Sum of } N \text{ instantaneous readings}}{N}$$

$$\text{IADR} = \frac{1}{N} * \sum_N \text{IDIR} = \text{Btu/hr/ft}^2$$

Collector Water Flow Rate - MWCL

$$\text{Mass Flow Rate} = \text{volume flow rate} * \text{density}$$

$$\text{MWCL} = \text{GWCL} * \text{PPGHS} = \text{lbs/minute}$$

Water density is determined for the measured temperature by a relationship linearized over the range of temperatures anticipated.

$$\text{PPGHS} = C_1 * \text{TWCL} + C_2 = \text{lbs/gallon}$$

with  $C_1 = -.0037$

$$C_2 = 8.784$$

#### Average Heat Collection Rate - Collector #1

Heat collected = water mass flow rate \* specific heat \* temperature rise

$$\text{QAC1} = \frac{1}{N} * \sum_N (\text{DATC1} * C_p * K_1 * \text{MWCL}) = \text{Btu/min}$$

with  $C_p = 1.0 = \text{Btu/lb/}^\circ\text{F}$

$$K_1 = 0.496$$

The constant K is included to express the portion of total collector water flow passed through collector #1. Due to unequal line lengths and physical configuration the individual flows are not presently one half the total flow rate.

#### Average Heat Collection Rate - Collector #2

Heat collected = water mass flow rate \* specific heat \* temperature rise

$$\text{QAC2} = \frac{1}{N} * \sum_N (\text{DTC2} * C_p * K_2 * \text{MWCL}) = \text{Btu/min}$$

with  $C_p = 1.0 = \text{Btu/lb/}^\circ\text{F}$

$$K_2 = 0.504 = 1 - K_1$$

#### Vapor Generator Average Heat Input - QAVG

Heat Input = water mass flow rate \* specific heat \* temperature difference

$$\text{QAVG} = \frac{1}{N} * \sum_N (\text{MWVG} * C_p * \text{DTVG}) = \text{Btu/min}$$

where

$$MWVG = GWVG * PPGVG = \text{lbs/min}$$

$$\text{and } PPGVG = C_1 * TWVG + C_2 = \text{lbs/gallon}$$

$$\text{with } C_1 = -.0037$$

$$C_2 = 8.784$$

#### Evaporator Average Cooling Rate - QAEV

Cooling = water mass flow rate \* specific heat \* temperature difference

$$QAEV = \frac{1}{N} * \sum_N (MWEV * C_p * DTEV) = \text{Btu/min}$$

$$\text{with } C_p = 1.0 \text{ Btu/lb/}^\circ\text{F}$$

$$MWEV = GWEV * PPGEV = \text{lbs/min}$$

$$\text{and } PPGEV = C_3 * TWEV + C_4 = \text{lbs/gallon}$$

$$\text{with } C_3 = -.0003$$

$$C_4 = 8.356$$

Here again water density at the measured temperature is determined by a linearizing density/temperature relationship for the anticipated range of temperatures.

#### Fan Coil Average Cooling Rate - QAFC

Cooling rate = water mass flow rate \* specific heat \* temperature difference

$$QAFC = \frac{1}{N} * \sum_N (MWFC * C_p * DTFC) = \text{Btu/min}$$

with  $C_p = 1.0 \text{ Btu/lb/}^\circ\text{F}$

$$\text{MWFC} = \text{GWFC} * \text{PPGFC} = \text{lbs/min}$$

and  $\text{PPGFC} = C_3 * \text{TWFC} + C_4 = \text{lbs/gallon}$

$$C_3 = -.0003$$

$$C_4 = 8.356$$

#### Chiller On Time Ratio - ONTM

Ratio =  $\frac{\text{number of scans with chiller on}}{\text{total number of scans in time period}}$

$$\text{ONTM} = \frac{1}{N} * \sum_N K_3$$

$K_3 = 1.0$ , with chiller operating

$K_3 = 0.0$ , with chiller not operating

#### System Up Status Ratio - SUPR

This parameter expresses the portion of time the system is capable of running (i.e., all premissives are satisfied) whether or not a demand for system operation is present.

Ratio =  $\frac{\text{number of scans with premissives satisfied}}{\text{total number of scans in time period}}$

$$\text{SUPR} = \frac{1}{N} * \sum_N K_4$$

$K_4 = 1.0$ , with premissives satisfied

$K_4 = 0.0$ , with premissives not satisfied

Data Reduction Program - Daily

The DAS output data recorded on magnetic tape is processed at UTRC and results combined to give a record of performance for each 15-minute interval and for the full day's operation. The following relationships are employed in processing the 15-minute interval data.

Insolation Normal to Collectors

$$\text{Normal insolation} = \text{direct insolation} * \cosine \theta$$

$$\text{IANOR} = \text{IADIR} * \text{COS}(\text{THETA}) = \text{Btu/hr/ft}^2$$

where

$$\text{THETA} = f(\text{time of day, day of year, and location})$$

and is calculated by a separate computer subroutine for the mid-time of each 15-minute interval. This is the angle between the run and a vertical east-west plane. With the north-south oriented collector array this modifies the averaged pyroheliometer readings of direct insolation to that normal to the collector.

Insolation on Collector Area

$$\text{Insolation} = \text{normal insolation} * \text{collector area}$$

The two collector banks are treated individually.

$$\text{QNC1} = \text{IANOR} * (\text{AC1} - 32 * \text{tangent } \theta) = \text{Btu/hr}$$

$$\text{QNC2} = \text{IANOR} * (\text{AC2} - 32 * \text{tangent } \theta) = \text{Btu/hr}$$

$$\text{with } \text{AC1} = \text{AC2} = 658.0 = \text{ft}^2$$

The last term of each equation expresses the collector banks end loss, i.e., that portion of area at one end whose reflected energy falls beyond the end of the receiver tube. If the angle were zero, of course, this loss is also reduced to zero.

Collector Average Efficiency

$$\text{Efficiency} = \frac{\text{energy collected}}{\text{input insolation}}$$

$$ETAC1 = 60 * QAC1/QNC1 = \text{decimal}$$

$$ETAC2 = 60 * QAC2/QNC2 = \text{decimal}$$

### Collector Parameter - DT/I

The standard parameter used in comparing collector efficiency is calculated for each collector bank and an average value provided.

$$DT/I = \frac{\text{average water temperature} - \text{ambient temperature}}{\text{normal insolation}}$$

$$DTIC1 = (TWCL - DT1/2 - TAMB)/IANOR$$

$$DTIC2 = (TWCL - DT2/2 - TAMB)/IANOR$$

and

$$DTAV = (DTIC1 + DTIC2)/2 = \frac{^{\circ}\text{F}}{\text{Btu/hr/ft}^2}$$

### Total Solar Heat Collection Rate

Total = sum of individual bank collection rates

$$QACL = QAC1 + QAC2 = \text{Btu/min}$$

### Freon Conditions

Saturation temperatures corresponding to measured pressures for each of the four major heat exchangers are calculated with UTRC computer subroutines which were created to solve equations for the refrigerant thermodynamic properties as provided in Technical Bulletin T-11 of E.I. DuPont Organic Chemical Department, Wilmington, Delaware, 19898.

These values are thus available for comparison with measured temperatures to insure data accuracy. Since for the power loop condenser no direct temperature measurement is provided, the value calculated from measured power condenser pressure (PFPC) is listed on the daily data printout (ref. TSPC).

Stored Water Conditions

The average temperature of water in the hot and cold water storage tanks is provided on the daily printout. Each is the average of measured temperatures of the four individual tank sections.

$$THSA = (THS1 + THS2 + THS3 + THS4)/4 = ^\circ F$$

$$TCSA = (TCS1 + TCS2 + TCS3 + TCS4)/4 = ^\circ F$$

Cooling Produced

$$\text{Cooling} = \frac{\text{evaporator heat input}}{200}$$

$$\text{TONS} = \text{QAEV} * 60/12000 = \text{Tons}$$

Coefficient of Performance (COP)

$$\text{COP} = \frac{\text{cooling rate}}{\text{vaporizer heat input rate} + \text{freon pump power}}$$

$$\text{COP} = \text{QAEV}/(\text{QAVG} + \text{QFP})$$

Freon pump power is calculated for the measured pressure conditions using a relationship which is correlated with measured power values taken during checkout tests in the UTRC laboratory.

$$\text{Power} = f (\text{power loop flow, pressure rise, overall efficiency})$$

$$\text{QFP} = K_7 * \text{PFVG} * (\text{PFVG} - \text{PFPC}) = \text{Btu/min}$$

where  $K_7 = 1.8433 \times 10^{-3}$  with an efficiency of 34%. In this expression, vaporizer freon pressure is a measure of power loop flow with choked flow through the fixed turbine nozzles area, and the pressure difference between power condenser and vaporizer is a measure of the head to be supplied by the pump. The input electrical energy lost due to motor inefficiency is not a thermodynamic input to the refrigerant power cycle and is hence not included in determination of chiller COP, but is included in determination of EER.

Daily Performance Summary

To provide a summary of a full day's operation, the data for all 15-minute time periods is combined to give summations and averages as pertinent to each parameter. Definition of each entry on the daily summary is provided below.

Chiller On Time

$$\text{ON Time} = \frac{\text{summation of 15 minute period ON time ratios}}{4}$$

$$\text{COT} = \sum \text{ONTM} * 15/60 = \text{hours}$$

System Up Time

$$\text{UP Time} = \frac{\text{summation of 15 minute period UP time ratios}}{4}$$

$$\text{SYSTEM UPTIME} = \sum \text{SUPR} * 15/60 = \text{hours}$$

Collector #1 Average Efficiency

$$\text{Daily Average Efficiency} = \frac{\text{sum of 15 minute period efficiencies}}{\text{number of 15 minute periods}}$$

$$\text{ETAC1} = \frac{1}{\text{NP}} * \sum \text{ETAC1} = \text{decimal}$$

Collector #2 Average Efficiency

$$\text{ETAC2} = \frac{1}{\text{NP}} * \sum \text{ETAC2} = \text{decimal}$$

Total Collector Solar Energy Input

Solar Energy Input = summation of average normal insolation  
rate \* time \* total collector area

$$Q_{ICL} = \sum_{NP} [IANOR * 15/60 * (AC1 + AC2)]/10^6 = \text{millions Btu}$$

with  $IANOR = \text{Btu/hr/ft}^2$

and  $AC1 = AC2 = 658.0 \text{ ft}^2$

Total Heat Energy Collected

$$Q_{COLL} = \sum_{NP} (Q_{ACL} * 15)/10^6 = \text{millions Btu}$$

Total Heat Input to Vapor Generator

$$Q_{VGEN} = \sum_{NP} (Q_{AVG} * 15)/10^6 = \text{millions Btu}$$

Total Cooling Provided by Evaporator

$$Q_{EVAP} = \sum_{NP} (Q_{AEV} * 15)/10^6 = \text{millions Btu}$$

Total Cooling Delivered by Fan/Coils

$$Q_{FCOIL} = \sum_{NP} (Q_{AFC} * 15)/10^6 = \text{millions Btu}$$

Heat Energy Lost From Hot Water Loop

Heat Loss = energy collected - energy input to vapor generator  
- change in hot storage energy

$$QHLOSS = \sum_{NP} \left[ [(QACL - QAVG) * 15] - QTHSE - QTHSB \right] / 10^6 = \text{millions Btu}$$

with QTHSE = stored energy at start of following day

QTHSB = stored energy at start of current day

Note that this loss includes the change in stored energy for the over-night time period even though the chiller and/or collector systems are not operating.

Stored energy is evaluated by a UTRC computer subroutine which treats the hot storage tank as four (4) individual sections of approximately equal volume, each at its measured temperature as provided by the DAS. Water density at the measured temperature is used to determine the mass of water in the fixed volume. Stored energy related to a reference temperature of 200°F is calculated by

$$Q = \text{mass} * \text{specific heat} * (\text{temperature} - 200) = \text{Btu}$$

Heat capacity of the tank metal associated with each section is treated similarly, metal temperature considered equal to the measured water temperature.

Values of energy stored in water and metal for the four tank sections are combined to determine total stored energy, again related to the reference temperature of 200°F. The reference temperature was so chosen to provide a measure of useful energy available to power the chiller module.

#### Cooling Energy Lost From Cold Loop

Cooling lost = cooling produced by evaporator - cooling delivered  
by fan/coils - change in cold storage energy

$$QCLOSS = \sum_{NP} \left[ [(QAEV - QAFC) * 15] - (QTCSE - QTCSB) \right] / 10^6 = \text{millions Btu}$$

with QTCSE = cold storage energy at end of day

QTCSB = cold storage energy at beginning of day

Treatment of cold storage energy at the UTRC computer subroutine directly parallels that for hot storage energy except that a reference temperature of 60°F is used. This reference temperature was similarly chosen to provide a measure of useful cooling energy available to meet a building cooling demand.

#### Daily Average Cooling Produced

$$\text{Cooling Rate} = \frac{\text{total cooling produced}}{\text{total operating time}}$$

$$\text{TONS} = \sum_{\text{NP}} (\text{QAEV} * 15) / (12000 * \text{COT}) = \text{Tons}$$

#### Daily Coefficient of Performance (COP)

$$\text{COP} = \frac{\text{total cooling rate}}{\text{total heat input rate to vapor generator} + \text{total from pump power}}$$

$$\text{COP} = \sum_{\text{NP}} \text{QAEV} / \sum_{\text{NP}} (\text{QAVG} + \text{QFP}) = \text{decimal}$$

This may also be expressed as:

$$\text{COP} = \frac{\text{daily average cooling rate}}{\text{daily average of heat input rate to vapor generator} + \text{total from pump power}}$$

$$\text{COP} = \frac{1}{\text{NP}} * \sum_{\text{NP}} \text{QAEV} / \frac{1}{\text{NP}} * \sum_{\text{NP}} (\text{QAVG} + \text{QFP}) = \text{decimal}$$

#### Daily Energy Efficiency Ratio

$$\text{Energy Efficiency Ratio} = \frac{\text{daily average cooling rate}}{\text{daily average electrical power}}$$

$$- \quad \text{EER} = \left( 60 * \frac{1}{\text{NP}} * \sum_{\text{NP}} \text{QAEV} \right) / \left( \frac{1}{\text{NP}} * \sum_{\text{NP}} \text{WATTS} \right) = \text{Btu/hr/Watt}$$

where

$$\text{WATTS} = \text{EFP} + \text{EPC} + \text{ECC} + \text{EVG} + \text{EEV} = \text{Watts}$$

and EFP = freon pump power

EPC = power condenser fan power

ECC = cooling condenser fan power

EVG = vaporizer water pump power = 1000 Watts

EEV = evaporator water pump power = 600 Watts

Condenser fan power (EPC, ECC) is a function of ambient temperature since the number of fans operating increases as ambient temperature rises and more cooling airflow is required. The schedule of condenser fan power is shown below.

| <u>Ambient Temp °F</u> | <u>Fan Power-Watts</u> |
|------------------------|------------------------|
| below 70               | 450                    |
| 70 to 75               | 900                    |
| 75 to 80               | 1350                   |
| 80 to 85               | 1800                   |
| above 85               | 2600                   |

#### Backup Energy Efficiency Ratio

The energy efficiency ratio of the backup roof-top units is a function of the ambient temperature and, based on manufacturers information, is calculated using

$$\text{BUEER} = 8.437 - .0687 (\text{TAMB} - 70) = \frac{\text{Btu/hr}}{\text{watt}}$$

To evaluate the daily average ambient temperature, the parameter degree-hours is utilized. This is the product of degrees above 70°F and operating time, which also provides a measure of the cooling demand for the operating period. For each 15-minute time period,

$$\text{DEGHRO} = .25 * (\text{TAMB} - 70) = \text{degree hours}$$

For the full day's operation,

$${}^{\dagger}\text{DEGHR} = \sum_{\text{NP}} \text{DEGHRO}$$

average daily ambient temperature, then, is

$$\text{TAMB} = 70 + (4 * \text{DEGHR}/\text{NP}) = {}^{\circ}\text{F}$$

An example of a daily data printout is provided in Table A-1 and a listing of the parameter names is provided in Table A-2.

#### Weekly/Monthly Performance Summaries

Weekly and monthly (as any multi-day time period) performance summaries are provided by a separate computer program utilizing daily performance summary parameters as input data. Definition of the resulting summary parameters is provided below.

$$\text{QICL} = \sum_{\text{ND}} \text{QICL} = \text{MBTU}$$

where ND is the number of days in the time period of interest.

$$\text{QCOLL} = \sum_{\text{ND}} \text{QCOLL} = \text{MBTU}$$

$$\text{QUGEN} = \sum_{\text{ND}} \text{QUGEN} = \text{MBTU}$$

$$\text{QHLOSS} = \sum_{\text{ND}} \text{QHLOSS} = \text{MBTU}$$

<sup>†</sup>(The daily printout shows this parameter in units of hundreds of degree hours)



TABLE A-2

## SOLERAS DAILY PRINTOUT PARAMETERS

The key data obtained every 15 min. during the day is printed out in a double row. The following list identifies the symbols used at the top of the page.

|       |   |                                                                                                 |
|-------|---|-------------------------------------------------------------------------------------------------|
| TIME  | - | Time of day, hours: min                                                                         |
| ONTM  | - | Fraction of the 15 min interval during which the chiller was running                            |
| TAMB  | - | Ambient temperature of the air entering the condenser, °F                                       |
| TRM1  | - | Room temperature in hall of HTS office, °F                                                      |
| IADIR | - | Direct solar intensity averaged over 15 min interval<br>Btu/hr/ft <sup>2</sup>                  |
| IANOR | - | Solar intensity normal to the collectors averaged over 15 min interval - Btu/hr/ft <sup>2</sup> |
| DTC1  | - | Temperature rise in water flowing through east collector row, F <sup>o</sup>                    |
| DTC2  | - | Temperature rise in water flowing through west collector row, F <sup>o</sup>                    |
| ETAC1 | - | Efficiency of east collector bank averaged over 15 min interval                                 |
| ETAC2 | - | Efficiency of west collector bank averaged over 15 min interval                                 |
| DT/I  | - | Collector parameter (collector temp. - amb. temp.)/normal solar intensity, °F hr/Btu            |
| RPM   | - | Turbine speed, rpm                                                                              |
| TWCL  | - | Water temperature leaving collector, °F                                                         |
| THSA  | - | Average temperature of water in hot storage tank, °F                                            |
| TWVG  | - | Water temperature entering vapor generator, °F                                                  |
| TFVG  | - | Freon temperature in vapor generator, °F                                                        |
| TSPC  | - | Saturation temperature of Freon in power condenser, °F                                          |
| TFCC  | - | Freon temperature in cooling condenser, °F                                                      |
| TFEV  | - | Freon temperature in evaporator, °F                                                             |

TABLE A-2 (Cont'd)

## SOLERAS DAILY PRINTOUT PARAMETERS

|       |   |                                                                                  |
|-------|---|----------------------------------------------------------------------------------|
| TWFC  | - | Water temperature going to fan coil, °F                                          |
| TCSA  | - | Average temperature of water in cold storage tank, °F                            |
| PFVG  | - | Freon pressure in vapor generator, psia                                          |
| PFPC  | - | Freon pressure in power condenser, psia                                          |
| PFEV  | - | Freon pressure in evaporator, psia                                               |
| PFCC  | - | Freon pressure in cooling condenser, psia                                        |
| QAEV  | - | Cooling energy provided by chiller averaged over 15 min interval, Btu/min        |
| QAVG  | - | Heat energy used by chiller averaged over 15 min interval, Btu/min               |
| QACL  | - | Heat energy collected by solar collectors averaged over 15 min interval, Btu/min |
| QAFC  | - | Cooling energy used by fan coils - averaged over 15 min interval, Btu/min        |
| GWCOL | - | Water flow to collectors, gal/min                                                |
| GWFC  | - | Water flow to fan coils, gal/min                                                 |
| TONS  | - | Chiller output, tons cooling                                                     |
| COP   | - | Chiller coefficient of performance                                               |
| CODE  | - | Chiller shutdown code (operational after August 1)                               |

The daily summary is printed at the bottom of the page. The following list identifies the daily symbols.

|                |   |                                                                                        |
|----------------|---|----------------------------------------------------------------------------------------|
| CHILL ON TIME  | - | Total time chiller is running, hr                                                      |
| SYSTEM UP TIME | - | Total time system is capable of running, hr                                            |
| ETAC1          | - | Daily efficiency of east collector bank                                                |
| ETAC2          | - | Daily efficiency of west collector bank                                                |
| DEGHR          | - | Convective building load parameter, hourly sum of ambient temp. above 70 F, deg-hr/100 |
| QICL           | - | Solar Energy incident on collectors, MBTU                                              |
| QCOLL          | - | Heat energy collected by solar collectors, MBTU                                        |
| QVGEN          | - | Heat energy used by vapor generator, MBTU                                              |

TABLE A-2 (Cont'd)

SOLERAS DAILY PRINTOUT PARAMETERS

- QHLOSS - Heat energy lost from hot loop, MBTU
- QEVAP - Cooling energy made in evaporator, MBTU
- QFCOIL - Cooling energy used by fan coils, MBTU
- QCLOSS - Cooling energy lost from cold loop, MBTU
- COP - Daily coefficient of performance
- EER - Daily average electrical efficiency rating, Btu/hr/Watt
- TONS - Daily average output of chiller when running
- BUEER - Estimated EER of back up air conditioners

$$QUEAP = \sum_{ND} QUEAP = \text{MBTU}$$

$$QFCOIL = \sum_{ND} QFCOIL = \text{MBTU}$$

$$QCLOSS = \sum_{ND} QCLOSS = \text{MBTU}$$

$$COT = \sum_{ND} COT = \text{HOURS}$$

$$SUT = \sum_{ND} SUT = \text{HOURS}$$

$$DEGHR = \sum_{ND} DEGHR = \text{DEGREE-HOURS}$$

$$ETAC1 = \frac{\sum_{ND} QCOLL}{\sum_{ND} \left( \frac{QCOLL}{ETAC1} \right)} = \text{decimal}$$

$$ETAC2 = \frac{\sum_{ND} QCOLL}{\sum_{ND} \left( \frac{QCOLL}{ETAC2} \right)} = \text{decimal}$$

The two preceding relationships assume that the daily distribution of heat collected by an individual collector bank is the same as the daily distribution of total heat collected.

$$\text{COP} = \frac{\sum_{\text{ND}} \text{QEUAP}}{\sum_{\text{ND}} \left( \frac{\text{QEUAP}}{\text{COP}} \right)} = \text{decimal}$$

$$\text{EER} = \frac{\sum_{\text{ND}} \text{QEUAP}}{\sum_{\text{ND}} \left( \frac{\text{QEUAP}}{\text{EER}} \right)} = \text{Btu/hr/watt}$$

$$\text{TONS} = \frac{\sum_{\text{ND}} \text{QEUAP}}{12,000 * \text{COT}}$$

$$\text{BUEER} = \frac{1}{\text{ND}} * \sum_{\text{ND}} \text{BUEER}$$

In addition to the data inputs provided by the daily data summaries, electrical powers used by the chiller, the fan/coils, and the back-up air conditioning system are measured and periodically recorded. For multi-day summaries, values for each power use are input for the beginning and end of the time period being summarized. Electrical energy used is taken as the difference of these values.

Chiller electrical energy:

$$\text{KWHCH} = \text{KWACH}_{t2} - \text{KWACH}_{t1} = \text{kilowatt hours}$$

Fan coil electrical energy:

$$\text{KWHFC} = \text{KWHFC}_{t2} - \text{KWHFC}_{t1} = \text{kilowatt hours}$$

Back-up electrical energy:

$$\text{KWHBU} = \text{KWHBU}_{t2} - \text{KWHBU}_{t1} = \text{kilowatt hours}$$

with these values, average chiller EER as determined from power measurement is

$$\text{EERPW} = \frac{\text{total cooling provided}}{\text{total electrical energy}}$$

$$\text{EERPW} = \frac{\sum_{\text{ND}} \text{QEUAP}}{\text{KWHCH} * 1000} = \text{Btu/hr/Watt}$$

Total cooling provided by the back-up air conditioning system is estimated as

$$\text{QACBU} = \text{KWHBU} * \text{BUEER}/1000 = \text{millions Btu}$$

The portion of total cooling provided by the solar-powered system is then

$$\text{SOLR} = \frac{\sum_{\text{ND}} \text{QFCOIL}}{\sum_{\text{ND}} \text{QFCOIL} + \text{QACBO}} = \text{decimal}$$

An example of the summary data provided for one 5-day time period (one week) is shown in Table A-3.

TABLE A-3  
SOLFRAS WEEKLY PERFORMANCE SUMMARY

| Chill,<br>ONTIME | System<br>UPTIME | ETAC1 | ETAC2 | DEGHR | MBTU   |       |       |        |       |        |        | COP  | EER  | TONS | BUFER |
|------------------|------------------|-------|-------|-------|--------|-------|-------|--------|-------|--------|--------|------|------|------|-------|
|                  |                  |       |       |       | QICL   | QCOLL | QVGEN | QHLOSS | QEVAP | QFCOIL | QCLOSS |      |      |      |       |
| 6/1/81<br>6.24   | 7.30             | .6183 | .6446 | 1.88  | 1.974  | 2.298 | 1.872 | .132   | .751  | .412   | .165   | .398 | 16.1 | 10.0 | 7.01  |
| 6/2/81<br>4.72   | 9.98             | .3807 | .2540 | 2.16  | 2.201  | 1.084 | 1.006 | -.079  | .343  | .385   | .123   | .339 | 10.0 | 6.1  | 7.05  |
| 6/3/81<br>.00    | 8.20             | .4743 | .4906 | 1.78  | 2.648  | 2.043 | .000  | .030   | .000  | .081   | .016   | .000 | .0   | .0   | 7.08  |
| 6/4/81<br>2.64   | 7.99             | .4319 | .4342 | 2.23  | 3.108  | 2.196 | .791  | .396   | .343  | .185   | .015   | .429 | 18.2 | 10.8 | 6.78  |
| 6/5/81<br>4.62   | 6.79             | .4278 | .4350 | 2.74  | 3.341  | 2.141 | 1.266 | .200   | .550  | .477   | .065   | .430 | 15.3 | 9.9  | 6.60  |
| SUMMARY          |                  |       |       |       |        |       |       |        |       |        |        |      |      |      |       |
| 18.21            | 40.26            | .4657 | .4442 | 10.79 | 13.272 | 9.762 | 4.935 | .679   | 1.987 | 1.540  | .383   | .399 | 14.6 | 9.1  | 6.90  |

KWICH = 150.0  
 KWHFC = 110.0  
 KWHBU = 200.0  
 EERPW = 13.2  
 QACBU = 1.381  
 SOLAR = .527

A-21