

CONF-970134--21

RECEIVED

JUN 17 1997

OSTI

SLAC-PUB-7352

November 1996

## Radiation Aspects of the B-Factory at SLAC\*

J. C. Liu, W. R. Nelson and X. S. Mao

Stanford Linear Accelerator Center, Stanford University, Stanford, CA 94309, USA

**Abstract** - The B-Factory is a high-energy physics project at SLAC that studies the phenomenon of CP violation from collisions between two stored beams; high energy electrons (HER, maximum 12-GeV) and low energy positrons (LER, maximum 4-GeV). Both the HER and LER are located in an underground tunnel of 2200-m-long circumference with a maximum stored current of 3 A. The injector consists of the existing SLAC 2-mile-long LINAC with two extraction and transport lines for both rings. Radiation aspects of the machine are addressed in the context of machine protection and personnel protection. Specific illustrations (e.g., the estimations of neutron, photon and synchrotron radiation environment in the ring tunnel and the radiation levels outside a typical Interaction Region, etc.) are given to show a few natures of the radiation issues for the B-Factory and the to reflect the appropriate SLAC policies on radiation safety.

Contributed to the Proceedings of the 1997 Midyear Health Physics Society Meeting, San Jose, CA January 6-9, 1997.

\* Work supported by the Department of Energy under contract DE-A-03-76SF00515

DISTRIBUTION OF THIS DOCUMENT IS UNLIMITED

HH  
**MASTER**

## DISCLAIMER

This report was prepared as an account of work sponsored by an agency of the United States Government. Neither the United States Government nor any agency thereof, nor any of their employees, make any warranty, express or implied, or assumes any legal liability or responsibility for the accuracy, completeness, or usefulness of any information, apparatus, product, or process disclosed, or represents that its use would not infringe privately owned rights. Reference herein to any specific commercial product, process, or service by trade name, trademark, manufacturer, or otherwise does not necessarily constitute or imply its endorsement, recommendation, or favoring by the United States Government or any agency thereof. The views and opinions of authors expressed herein do not necessarily state or reflect those of the United States Government or any agency thereof.

**DISCLAIMER**

**Portions of this document may be illegible  
in electronic image products. Images are  
produced from the best available original  
document.**

## Introduction

The B-Factory project at the Stanford Linear Accelerator Center (SLAC) studies the CP violation from collisions between circulating electrons and positrons. Two storage rings are used in an existing underground ring tunnel of 2200-m-long circumference (see Fig. 1); a high energy electron ring (HER, 12-GeV maximum) about one meter below a low energy positron ring (LER, 4-GeV maximum). The tunnel is divided into six arc sections and six straight sections. There are six Interaction Regions (IRs) in the straight sections around the tunnel, and one of them (IR 2) is used to house the BaBar detector, in which the beam-beam collisions occur. The injector consists of the existing SLAC 2-mile-long LINAC with two extraction and transport lines from LINAC to rings.

In this paper, radiation aspects of the B-Factory are addressed in the context of machine protection and personnel protection with two examples. First, the designed maximum stored beam of 3 A for each ring is one order of magnitude higher than the currents of other existing electron storage ring facilities. Therefore, the radiation (synchrotron radiation and shower radiation) environment inside the tunnel is very harsh and needs to be estimated to protect the machine itself and the equipments to be placed in the tunnel. Second, the tunnel is underground with at least 5.5 m of earth berm and, thus, the IRs and penetrations have the weakest shielding. The dose levels outside an IR, the near-by penetrations, and SLAC boundary, resulting from various beam loss scenarios, need to be considered for personnel protection purposes.

## **Radiation Environment Inside the Ring Tunnel**

Interest was expressed to place electronic devices in the arc sections of the tunnel for cost reasons. Therefore, estimations of the doses to the electronics from synchrotron radiation and the shower radiation (gamma and neutron) were made. The methodology and the results of the dose calculations are summarized below with detail described elsewhere (Kase et al. 1993; Liu et al. 1995; Liu and Nelson 1995; Liu and Nelson 1996).

Figure 2a shows the elevation view of the LER atop the HER sitting on an arc section of the tunnel floor. Doses have been calculated at three locations (F, G and G-2), but only the dose results at the optimum position, point F (50 cm below the midpoint of the HER bending magnet), will be described. Figure 2b shows a cross sectional view of the tunnel at point F. Note that the half-cell length (from dipole to dipole) is 7.6 m. The LER arc vacuum chamber has 1-cm-thick aluminum wall and it uses an antechamber design to house a photon absorber 6 m downstream of every LER dipole to absorb the synchrotron radiation (SR) in a local spot. The HER has a near-rectangular arc vacuum chamber (5 mm thick copper wall) inside a C-shape bending magnet which has a 5.4 m long bending length. The thick iron magnet will significantly attenuate the radiation. Therefore, it is expected that there will be an intense, narrow beam of radiation (particularly for synchrotron radiation) emitted in the median plane of the HER ring and exiting from the opening of the C-shaped bending magnet.

## Synchrotron radiation dose

Figure 2b also outlines the steps to calculate the synchrotron radiation dose at point F. An EGS4 (Nelson et al. 1985) user code was developed to calculate the synchrotron radiation doses at certain distances away from the vacuum chamber, i.e.,  $D_0$ . These distances were actually chosen to reflect the doses to the magnet coil insulation, so that its possible damage by SR can also be estimated (Liu et al. 1995). At point F, the direct synchrotron radiation dose contribution ( $d_i$ ) is insignificant due to the thick shield of the long HER C-shaped dipole. To estimate the concrete-wall scattering contribution ( $S_c$ ), the dose at the surface of the concrete wall and the surface area illuminated by the dose level were calculated using the distance law. Then, an albedo factors ( $\alpha$ ) of 0.005, a scattering surface area ( $A$  in  $m^2$ ), and the distance ( $r$  in m) were used to calculate the dose scattered back to the desired dose point.

For the LER contribution, Fig. 3 shows that the peak dose level at 30 cm on the left side of the SR absorber (a point synchrotron radiation source) was calculated to be  $5 \times 10^5$  Gy  $y^{-1}$ . Using the  $r^{-2}$  law and the scattering parameters shown in Fig. 3, the scattered dose from the left side of the concrete wall is 0.4 Gy  $y^{-1}$  to point F. The dose at 30 cm on the right side was calculated to be half of the dose on the left side (i.e.,  $2.5 \times 10^5$  Gy  $y^{-1}$ ). The scattered dose from the right side was 0.2 Gy  $y^{-1}$  to point F. Because of the long HER bending length, the linear power profile of the synchrotron radiation from the HER was assumed to be uniform around the ring and the  $r^{-1}$  law was used. The dose at 8 cm on the right side of the HER chamber was 2500 Gy  $y^{-1}$ . This results

in a scattered dose of  $0.3 \text{ Gy y}^{-1}$  to point F. Therefore, the total synchrotron radiation dose at point F is  $0.9 \text{ Gy y}^{-1}$  (due to wall-scattering; 0.6 from LER and 0.3 from HER).

### **Neutron dose from shower radiation**

A few assumptions were made in the estimation of the doses from shower radiation. The beam loss scenarios during various modes of operation (Bloom 1993) including injection and stored beam were used to obtain the annual beam particle loss in the ring ( $6.1 \times 10^{17}$  beam particles) and all losses were assumed to be distributed uniformly around each ring. For neutron dose estimation, the beams were assumed to hit a cylindrical iron target (2" radius and 12" length) and there was no neutron self-shielding by the target. Only the neutron shielding from the long, C-shaped HER bending magnet was considered.

The analytical SHIELD11 code (developed at SLAC based on empirical formula) was used to calculate the direct neutron dose component ( $d_i$  in Fig. 2). The HER and LER contribute 0.6 and  $0.2 \text{ Gy y}^{-1}$  to point F, respectively. For the HER scattering components, the neutron dose at 1 m from the vacuum chamber was first calculated with SHIELD11 to be  $0.4 \text{ Gy y}^{-1}$ . Using the  $1/r$  law for a line source, the dose at the concrete wall was obtained as  $0.2 \text{ Gy y}^{-1}$ . Using the same distance law, the surface area of the concrete wall illuminated by the dose level was estimated to be  $1.2 \text{ m}^2$ . An albedo factor of 0.1 for neutron was used. This albedo method gave a dose of  $0.01 \text{ Gy y}^{-1}$  to point F from HER. To estimate the LER scattering neutron dose, the MORSE code (Emmett 1983) was used. A geometry with an infinite line source inside the axis of an

infinite cylinder was used to approximate the geometry of the LER inside the ring tunnel. The wall-scattering dose from the MORSE estimations gave  $0.1 \text{ Gy y}^{-1}$  neutron to point F. Therefore, the total neutron dose at point F is  $0.9 \text{ Gy y}^{-1}$  (0.3 LER and 0.6 HER).

### **Gamma dose from shower radiation**

The gamma (including also the secondary electrons from shower) dose from the shower radiation was estimated more accurately using the EGS4 code. Figure 4 shows a cross section (X-Y) view of the tunnel in the arc section as used in the EGS4 geometry simulation. The geometry of the HER and LER vacuum chambers (targets along which beams hit with shallow angles) and the HER bending magnet (as shielding) inside the concrete tunnel were taken into account in the simulation. A  $25 \times 25 \text{ cm}^2$  polystyrene phantom was placed between the HER dipole and the floor to simulate the electronic equipment. Utilizing the reciprocity principle and the energy-deposition estimator in the EGS4 calculations, the doses in the phantom were then calculated.

The 3-dimensional depth-dose profiles in the phantom (divided into  $25 \times 25 = 625$  sub-zones), with and without the 1-cm-thick iron shielding on the left side of the phantom, are shown in Fig. 5 for shower radiation from the LER and HER ( $X=0$  is the left side and  $Y=25$  is the top side). Note that the dose values in Fig. 5 need to be multiplied by  $2.77 \times 10^{16}$  to obtain the annual dose, making  $10^{-16} \text{ Gy}$  per incident particle equivalent to  $2.8 \text{ Gy y}^{-1}$ . For example, the left-surface dose (no iron shield) from the LER is  $2 \times 10^{-15} \text{ Gy inc}^{-1} = 55 \text{ Gy y}^{-1}$  and the iron on the left reduces the surface dose from the LER to  $3 \text{ Gy y}^{-1}$ . The total dose is dominated by the LER.

## **Dose summary**

The doses to the electronic equipment, placed under the HER dipole and shielded with 1-cm iron on the left side, from the synchrotron radiation, neutron and gamma radiation are summarized in Table 1. The maximum dose is  $5.6 \text{ Gy y}^{-1}$ , about a factor of two lower than the corresponding damage threshold of 100 Gy, when integrated over a 10-year use period.

## **Radiation Levels around an Interaction Region**

The IR 8, shown in Fig. 6, is 20-m-long along beam direction. A 102-cm-thick concrete shielding wall, separating the ring from the hall where workers can occupy, is 5.5 m from the ring beam lines. The 61-cm-thick concrete roof shielding is 10 m above the beam lines. Typical "penetrations" considered include a 2-bend personnel entrance maze, twelve RF waveguide penetrations, and two large utility shafts and two equipment accessways on both sides of the IR. Because IR 8 is in one of the two injection straight sections, the radiation levels around IR 8, the penetrations, the Support Building (the PEP Control Room), and SLAC boundary from as many as seven normal beam loss scenarios were addressed.

Table 2 summarizes the dose levels for five normal beam losses inside IR 8, estimated using SHIELD11, EGS4 and skyshine programs. The 25% beam loss in the septum during the 6-min per hour injection and the stored beam dump (one per two hour) in the graphite dump of the beam abort system (BAS) were the dominant radiation sources. It was found that a 76-cm-thick

concrete shielding on the sides of the septum and graphite dump was necessary to reduce the annual dose level outside the concrete wall below the design limit of  $1 \text{ rem y}^{-1}$  (for radiation workers). The IR 8 roof needs to be classified as Radiation Area and its access controlled for non-radiation workers. Due to the neutron skyshine, the Support Building and the nearest SLAC boundary (where general people occupies) have annual doses of 88 and 9  $\text{mrem y}^{-1}$ , respectively, less than the corresponding design limits of  $100 \text{ mrem y}^{-1}$  (for non-radiation workers) and  $10 \text{ mrem y}^{-1}$  (an internal limit). Similar to other penetrations, the dose levels on top of the RF waveguide penetrations were estimated with standard albedo (scattering) and ducting methods.

In addition, it is the SLAC policy to address the doses from the maximum credible beam and the mis-steering beam loss scenarios. A credible beam loss scenario was assumed to be that either the 3-A stored beam or the injection beams can get lost at any single point around the ring. For the injection beam, it was also assumed that the beam power limiting devices have also failed and the maximum credible beam power was 10 kW for positrons and 667 kW for electrons. For the mis-steering beam losses, the nominal beam power values were used. With these assumptions, the maximum dose outside the IR 8 concrete wall was 24  $\text{mrem}$  if both stored beams were lost at a point inside IR 8. This dose is less than the SLAC limit of 3  $\text{rem}$  per event. The corresponding dose level from a maximum credible injection beam loss is  $183 \text{ rem h}^{-1}$ , higher than the SLAC limit of  $25 \text{ rem h}^{-1}$ . However, the vacuum chamber or the collimators intercepting the beam can not withstand such a high power and will be burned through within a short time period. This will render the beam to be shut off by a vacuum failure. Therefore, the integrated dose per event of a maximum credible injection beam loss is still less than 3  $\text{rem}$ . There are two neutron-photon

radiation detectors outside IR 8 to turn off the injection beams, if radiation levels high than the preset is detected.

## **Conclusions**

The B-Factory is a large accelerator complex which has LINAC, transport lines and two storage rings with high stored currents. Various radiation estimations for the purposes of machine and personnel protection have been performed using Monte Carlo codes and empirical methods, albeit only two examples are shown to reflect the SLAC situations. Although the uncertainty of beam loss scenarios might introduce large errors to the dose calculations, there are still rooms for the improvement of the radiation calculation techniques. The non-uniform policies and calculation procedures within accelerator community for a few major areas (beam failure modes and dose limits) also need to be resolved.

## **References**

- Bloom, E. PEP-II injection beam losses. Stanford Linear Accelerator Center, CA; SLAC internal memo, PEP-II MS 98, Jan. 6; 1993.
- Emmett, M. B. The MORSE Monte Carlo Radiation Transport Code System. Oak Ridge National Laboratory, Oak Ridge, TN; ORNL-4972/R1; 1983.
- Kase, K.R.; Mao, S.; Nelson, W.R.; and Ipe, N.E. PEP-II radiation environment. SLAC, Stanford, CA, RP-93-5; 1993.

Liu, J.C.; Mao, S.; Nelson, W.R.; Kase, K.R. and Ipe, N.E. Calculations of the radiation doses to the electronic equipment and magnetic coil insulation in the PEP-II tunnel. Nucl. Instru. Meth. A359:463-473; 1995.

Liu, J.C. and Nelson, W.R. Synchrotron radiation calculations using the EGS4 code. Nucl. Instru. Meth. A360:626-633; 1995.

Liu, J.C. and Nelson, W.R. EGS4 Calculations of the dose to the electronic equipment in the PEP-II ring. accepted for publication in Nucl. Instru. Meth. 1996.

Nelson, W. R.; Hirayama, H. and Rogers, D. W. O. The EGS4 Code System. Stanford Linear Accelerator Center (SLAC), CA, 94309; SLAC-265; 1985.

## Figure caption

- Figure 1. The B-Factory accelerator complex includes the existing SLAC 2-mile-long LINAC, 2 transport lines from LINAC to ring, and two storage rings (LER and HER) in a 2200-m-circumference underground ring tunnel. The BaBar detector is located in one of the six Interaction Regions (i.e., IR 2).
- Figure 2. The ring components of the LER and HER and the steps of the dose calculations for the direct and the concrete-wall-scattering components.
- Figure 3. The direct doses (calculated with EGS4) and the scattered doses (calculated with albedo method) from the synchrotron radiation leaking out of the HER and LER vacuum chambers.
- Figure 4. Cross-section (X-Y) view of the PEP-II ring tunnel in the arc section used in the EGS4 geometry simulation (the length of Z-axis = 100 m is not shown). See text for detail.
- Figure 5. Three-dimensional depth-dose profiles in the phantom from the LER and HER, with and without the iron shielding on the left. X=0 is the left surface and Y=25 is the top surface, and  $10^{-16}$  Gy per incident beam particle corresponds to about 2.8 Gy  $y^{-1}$ .
- Figure 6. Radiation levels around the Interaction Region 8, located in one of the two injection straight sections, and its near-by penetrations resulting from various beam losses scenarios.

Table 1. Summary of total dose ( $\text{Gy y}^{-1}$ ) to the electronic devices (contributed by gamma, neutron and synchrotron radiation) placed below the HER dipole. A shielding of 1-cm-thick iron is placed on the left side of the equipment.

	LER	HER	Total
Gamma Radiation	3	0.8	3.8
Neutron Radiation	0.3	0.6	0.9
Synchrotron Radiation*	0.6	0.3	0.9
Total	3.9	1.7	5.6

\* Excluding the attenuation by the iron.

Table 2. Radiation levels around IR 8, the RF penetrations, and SLAC boundary from normal and accident beam loss scenarios. The numbers inside the parenthesis are the neutron and photon doses, respectively (units in mrem  $y^{-1}$  unless otherwise stated).

Location	Concrete Wall	Support Building	SLAC Boundary	IR Roof (mrem $h^{-1}$ )	RF Penet. (mrem $h^{-1}$ )
Occupancy period	2000 h $y^{-1}$	2000 h $y^{-1}$	7200 h $y^{-1}$	NA	2000 h $y^{-1}$
1. Injection beam loss in septum (8.5 W in IR center)	380 (290,90)	45	4.5	6 (2.6,3.4)	39 (14,25)
2. Stored beam dump in BAS (7.5 W in IR center)	420 (250,170)	39	3.9	6	30 (5,25)
3. Beam loss from PM (0.01 W along IR 8)	3	0.05	0.005	0	0
4. Keep-alive beam (220 W in dump)	52 (44,8)	0.7	0.1	0.13 (0.04,0.09)	450 (50,400)
5. All beam losses (0.56 W along IR 8)	146	3	0.3	0	NA
Total annual dose	1000	88	9	NA	519
Annual design limit	1000	100	10	NA	1000

1. An additional 76-cm-thick concrete shielding was used on the sides of the septum and the beam abort system (BAS) dump.
2. A 5-cm-radius, 30-cm-long copper target was assumed, except for the graphite BAS dump and the thin Al profile monitor (PM).
3. For RF penetrations, the x-rays from the cavities were also considered but were insignificant.

SLAC/LBL/LLNL  
 SLAC-Based B Factory:  
 PEP-II and BABAR

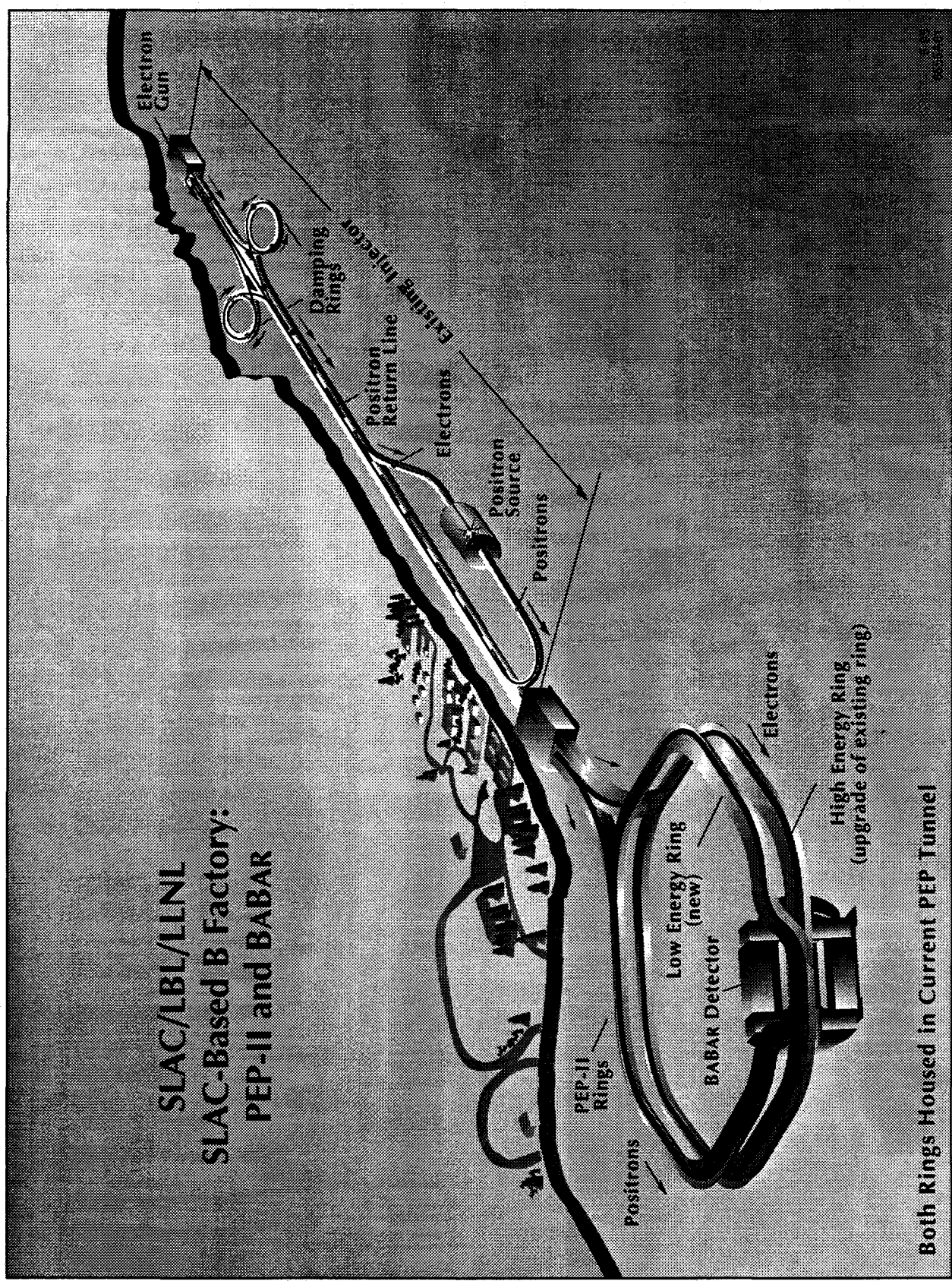

Both Rings Housed in Current PEP Tunnel

Fig. 1

(a) Tunnel Elevation View

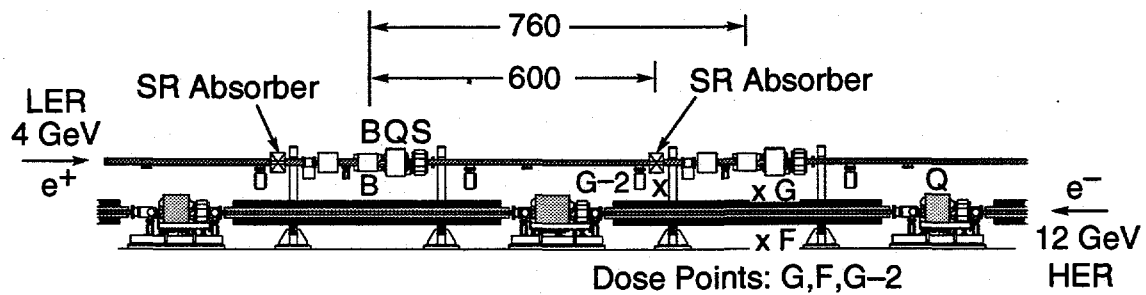

(b) Tunnel Cross Section

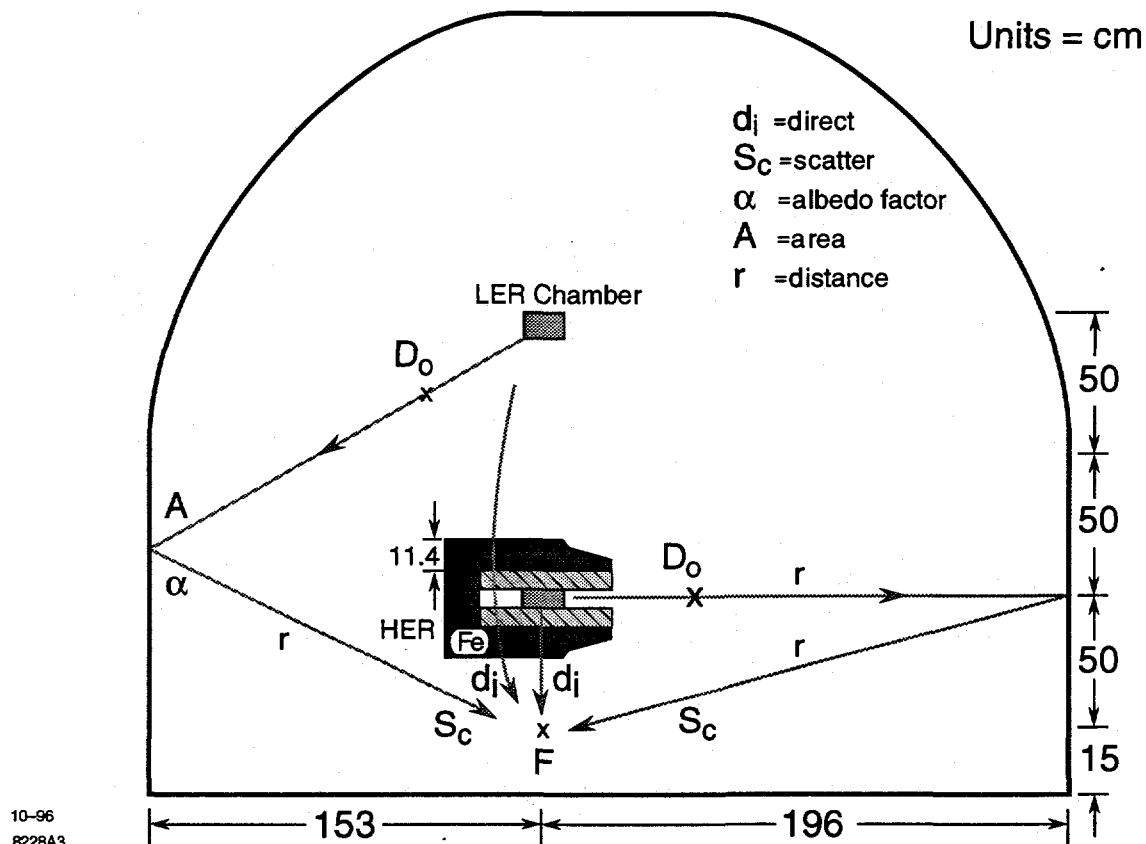

10-96  
8228A3

Fig. 2

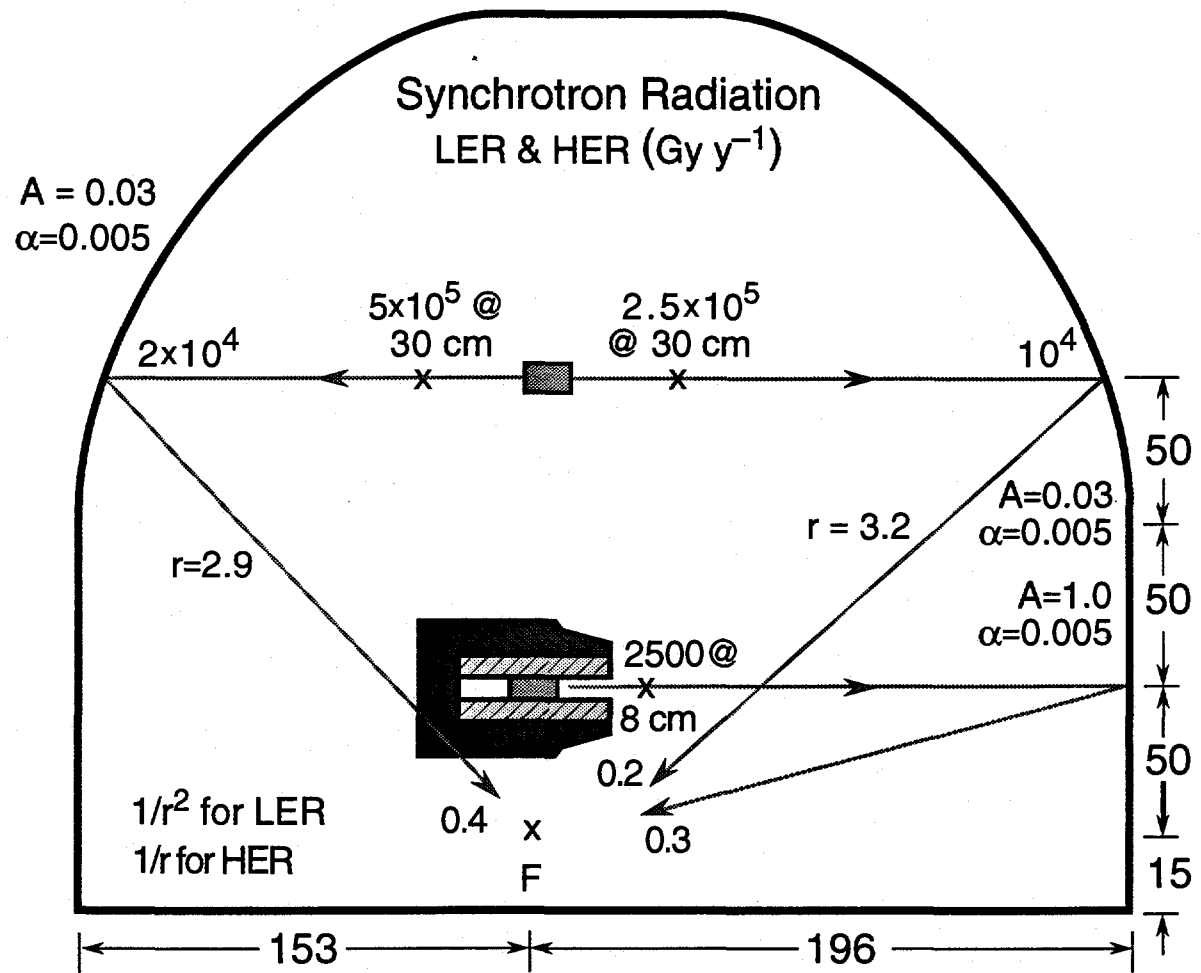
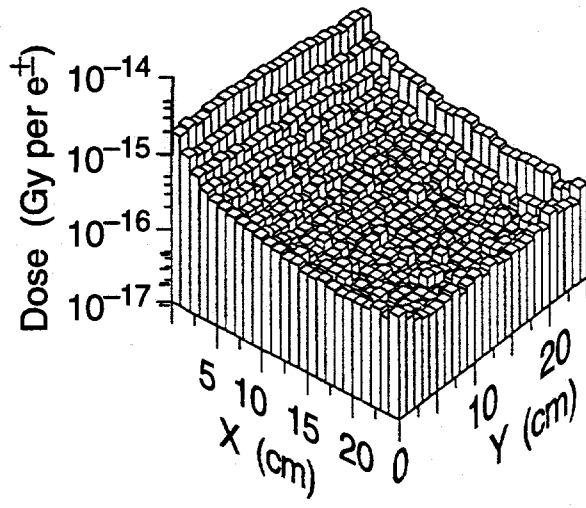
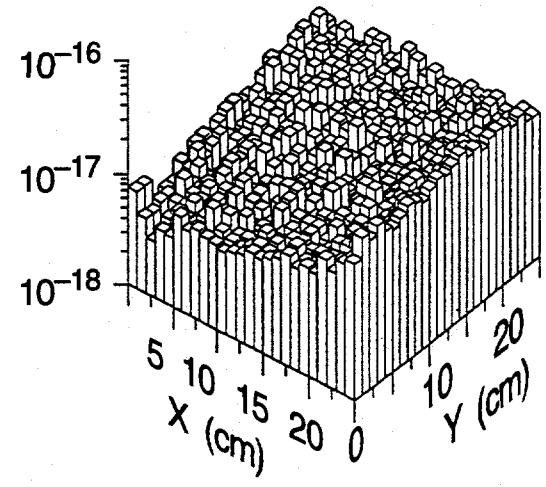

Fig. 3





LER (no shield)



HER (no shield)

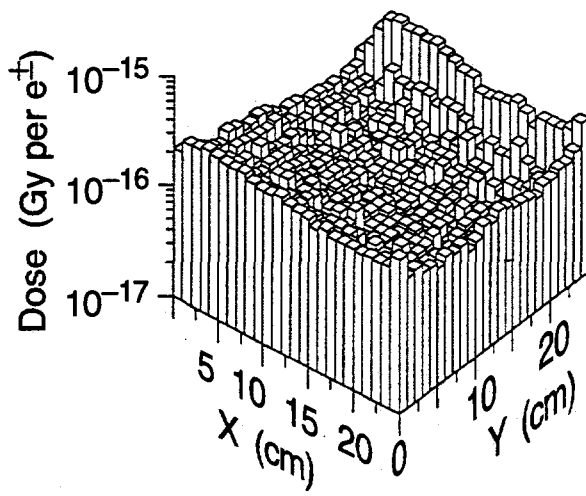

LER (1-cm Fe)

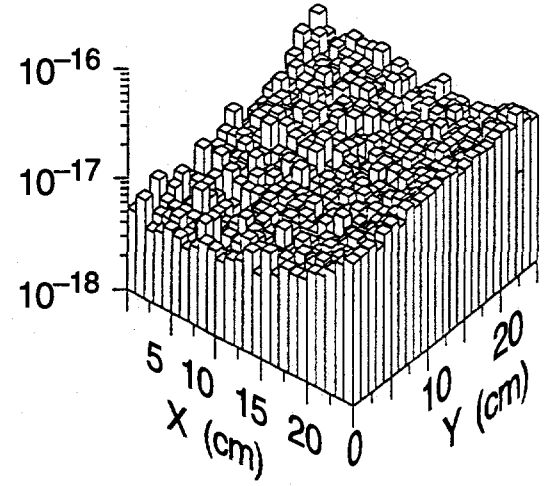

HER (1-cm Fe)

Fig. 5

