

170
4-21

UC-38

2114

NASA SP-5951(01)

MASTER

TECHNOLOGY UTILIZATION

ELECTRONIC TEST AND CALIBRATION
CIRCUITS

A COMPILATION



NATIONAL AERONAUTICS AND SPACE ADMINISTRATION

DISTRIBUTION OF THIS DOCUMENT IS UNLIMITED

DISCLAIMER

This report was prepared as an account of work sponsored by an agency of the United States Government. Neither the United States Government nor any agency thereof, nor any of their employees, makes any warranty, express or implied, or assumes any legal liability or responsibility for the accuracy, completeness, or usefulness of any information, apparatus, product, or process disclosed, or represents that its use would not infringe privately owned rights. Reference herein to any specific commercial product, process, or service by trade name, trademark, manufacturer, or otherwise does not necessarily constitute or imply its endorsement, recommendation, or favoring by the United States Government or any agency thereof. The views and opinions of authors expressed herein do not necessarily state or reflect those of the United States Government or any agency thereof.

DISCLAIMER

Portions of this document may be illegible in electronic image products. Images are produced from the best available original document.

Foreword

The National Aeronautics and Space Administration and the Atomic Energy Commission have established a Technology Utilization Program for the dissemination of information on technological developments which have potential utility outside the aerospace and nuclear communities. By encouraging multiple application of the results of their research and development, NASA and AEC earn for the public an increased return on the investment in aerospace research and development programs.

This compilation presents a wide variety of simple test and calibration circuits for use by the engineer and laboratory technician. The majority of the circuits contained in the four sections of the compilation have general application and are relatively inexpensive to assemble.

Additional technical information on individual devices and techniques can be requested by circling the appropriate number on the Reader Service Card included in this compilation.

Unless otherwise stated, NASA and AEC contemplate no patent action on the technology described.

We appreciate comment by readers and welcome hearing about the relevance and utility of the information in this compilation.

Jeffrey T. Hamilton, *Director*
Technology Utilization Office
National Aeronautics and Space Administration

NOTICE • This document was prepared under the sponsorship of the National Aeronautics and Space Administration. Neither the United States Government nor any person acting on behalf of the United States Government assumes any liability resulting from the use of the information contained in this document, or warrants that such use will be free from privately owned rights.

For sale by the National Technical Information Service, Springfield, Virginia 22151. \$1.00

Contents

	Page
SECTION 1. Testing Electronic Devices and Components	
Tester Checks Operational Performance of Circuit	
Breakers	1
Latching Overcurrent Circuit Breaker	1
Signal Generator for Testing Microcircuits	2
Magneto-resistor Monitors Relay Performance	3
Semiconductor Devices Can Be Tested Without Removal from Circuit	4
Novel Circuit Extends Usefulness of Clip-On Ammeter	4
Chatter Detector with 1 μ sec Response Sensitivity	5
SECTION 2. Instrument and System Test	
Frequency and Voltage Sensor Circuit	6
Automated Verifier Unit for Computer Card Punch Equipment	6
PCM Sync-Loss Indicator	7
Recording System Measures Power Transients	7
Tester Periodically Registers DC Amplifier Characteristics	8
Variable Load Automatically Tests DC Power Supplies	9
Electronic Ripple Indicator	9
Electronic Test Device Senses Malfunctions in Test Instrumentation	10
SECTION 3. Calibration and Reference Circuits	
Precision Calibration and Reference Voltage Source for Data Acquisition Systems	10
Raster Linearity of Video Cameras Calibrated with Precision Tester	11
Low Value Resistors and Shunts Calibrated with Modified Double Bridge	12
Radiometric Temperature Reference	12
Potentiometric Source-Resistance Meter	13
Precision Bolometer Bridge	13
Calibration of High Voltage Divider	14
Strain Gage Transducer Bridge Calibrated Remotely	15
SECTION 4. Simple Test Procedures	
Locating Sneak Paths in Electrical Circuitry	15
Color Identification Testing Device	16
Phase Detector Ensures Proper Phasing in Power Circuits	17
Electrical Continuity Scanner Identifies Connector Wires	17
Safety Circuit Senses Fuel Ignition	18
Detector Circuit Measures Relay Chatter Duration	19
Helium Background Suppressor Circuit Improves Sensitivity of Leak Detector	19
Electronic Clamp Circuit Improves Performance of Ultrasonic Transducer	20

Section 1. Testing Electronic Devices and Components

TESTER CHECKS OPERATIONAL PERFORMANCE OF CIRCUIT BREAKERS

The tester shown in the schematic measures the triptime of circuit breakers in accordance with the manufacturer's specifications. The tester can also subject the circuit breaker to a specified

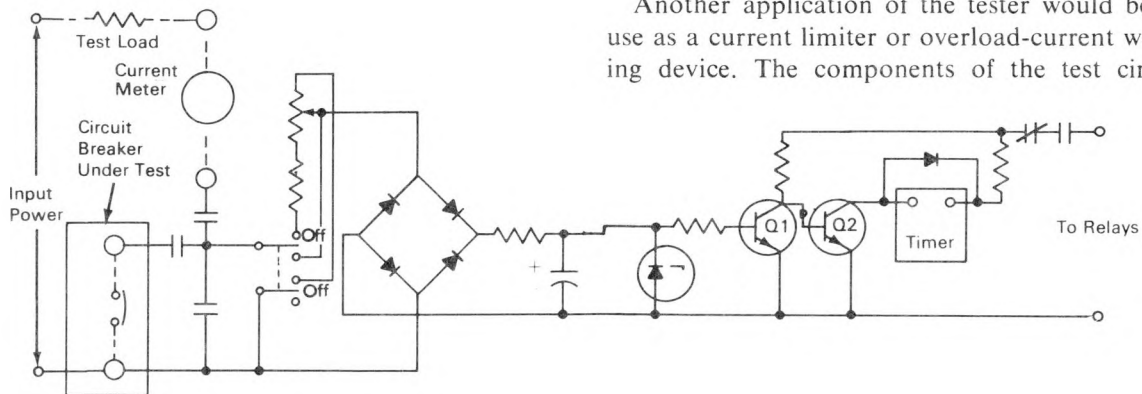

from the circuit breaker if it does not trip prior to the maximum allowable test time. In addition, currents, voltages, and operational times can be monitored for each relay.

Another application of the tester would be its use as a current limiter or overload-current warning device. The components of the test circuit

current and operational lifetime, with the circuit breaker's lockout device installed.

The circuit breaker tester contains an elaborate current limiter to protect the device in the event that a relay with a short circuit is being tested. A time-delay relay, with ranges applicable to the tripping time of the circuit breakers, is provided. The function of the relay is to remove power

were selected for minimum cost and micro-miniaturization capability.

Source: C. Cole of General Electric Co. under contract to NASA Headquarters (HQN-10340)

Circle 1 on Reader Service Card.

LATCHING OVERCURRENT CIRCUIT BREAKER

Manufacturers of electrical test equipment and small appliances, and personnel concerned with repeated nondestructive preflight testing, should be interested in a latching overcurrent circuit breaker. It consists of a preset current-amplitude sensor, and a lamp-photoresistor combination in a feedback arrangement which energizes a power switching relay. The ac input power is removed from the load at predetermined current amplitudes.

A double pole latching relay (see fig.) interrupts both sides of the ac line from the control cir-

cuit and the ac load to be controlled. A 3.9Ω resistor (R1), placed in series with one side of the line, produces a small voltage drop proportional to the amount of current drawn by the ac load. A dc voltage to the unijunction transistor (Q1) is supplied by a bridge rectifier. The 15Ω resistor (R2) provides current limiting, and the $47 \mu\text{f}$ capacitor (C1) provides filtering. A 390Ω resistor (R3) supplies temperature compensation for the unijunction transistor. The sensor for the circuit is a combination light dependent resistor (LDR) and lamp assembly.

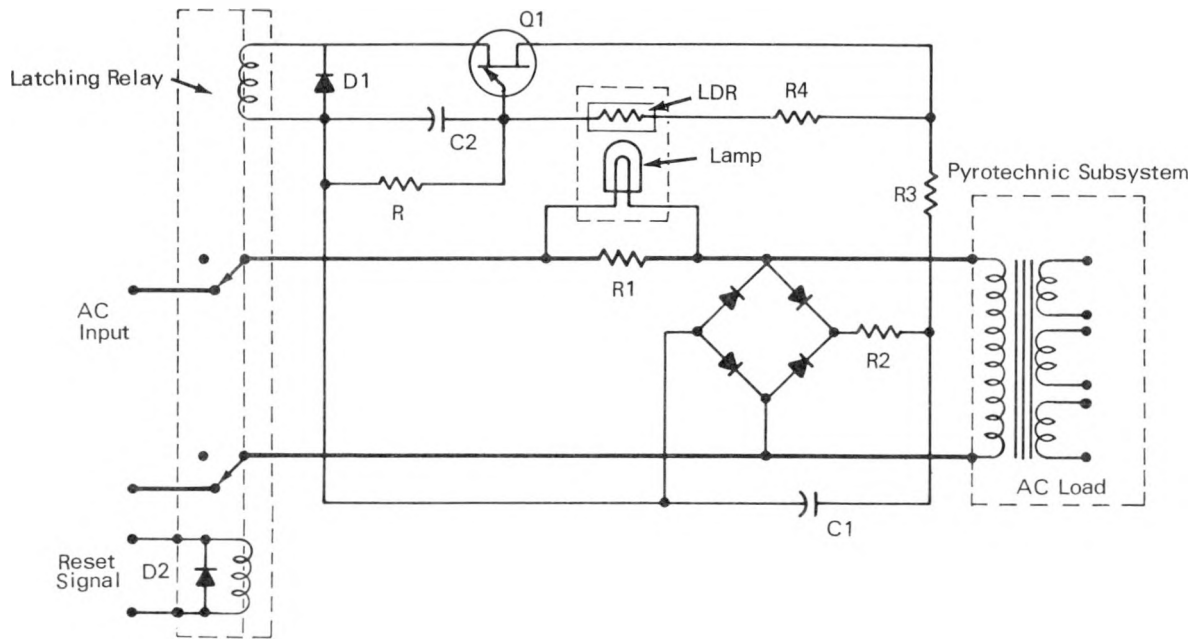

As the load current increases, the illumination from the lamp increases and lowers the resistance of the light dependent resistor. C2 charges to the peak point voltage of the unijunction transistor, causing it to fire. This action energizes the latching relay, causing the ac power line to be disconnected from the load and control circuit.

Source: M. L. Moore of Caltech/JPL under contract to NASA Pasadena Office (NPO-11131)

No further documentation is available.

SIGNAL GENERATOR FOR TESTING MICROCIRCUITS

A comprehensive semiconductor failure analysis requires the electrical isolation of the elements from one another. Since the elements are electrically interconnected with metallization stripes having widths as small as 0.0003 in., mechanical severing with a microprobe often leads to unwanted mechanical damage to the surrounding metallization stripes or to the silicon substrate. A high voltage spike generator, with the electrical schematic shown in the figure, uses capacitive discharges to isolate individual elements (transistors, diodes, resistors) by selectively open circuiting the metallization stripes on the silicon die. Selected capacitors are charged to a given voltage and abruptly discharged to cause an open circuit in the stripe. Tungsten carbide micromanipulator probes are used as contacts to

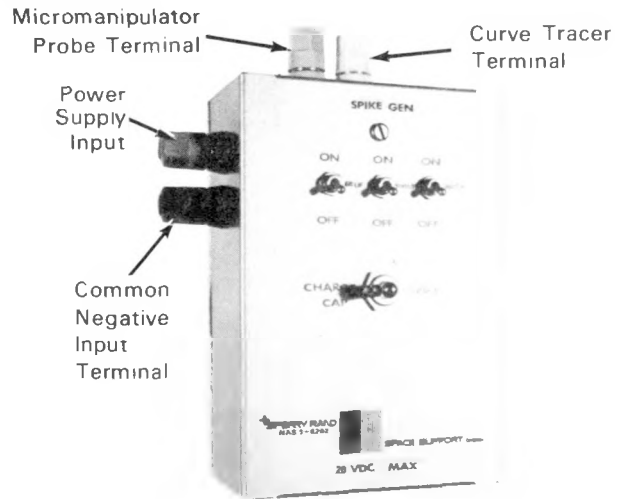
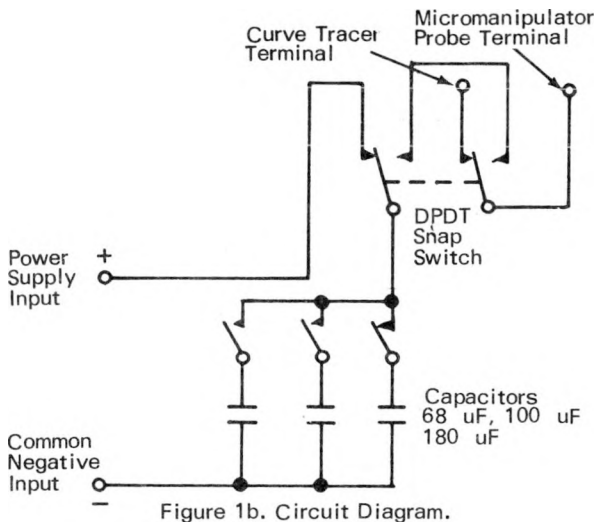

Figure 1a. Assembled Generator, One Half Actual Size.



the stripes. A snap switch is set to a charge condition. This allows the capacitors to charge and permits the probe contacts to be monitored. The values of the capacitors are 68, 100, or 180 μF (or any parallel combination of the three). A capacitance value of 168 μF at 8 V is satisfactory for open circuiting a 0.0005 in. wide aluminum stripe.

Source: G. L. Jacobs, D. F. Kizer, and J. T. Szczepkowski of Sperry Rand Corp. under contract to Goddard Space Flight Center (GSC-11107)

No further documentation is available.

MAGNETORESISTOR MONITORS RELAY PERFORMANCE

The waveforms of electrical relays can be monitored with a test setup that does not alter the circuit parameters or degrade relay performance. Malfunctions such as lack of armature movement, friction, welded contacts, and low

change in the magnetic flux. The waveform is then displayed on an oscilloscope. Voltage and current conditions, as functions of time, can be interpreted to determine the characteristic signature of a given relay.

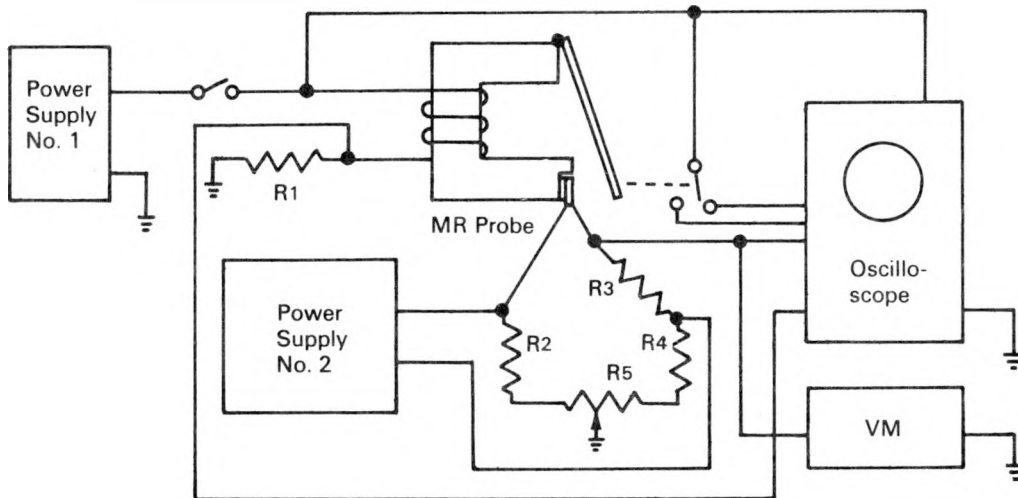

coil voltage can be determined from the transient waveforms (signatures). The characteristic signature of the relay is obtained from measurements of the magnetic flux produced under transient operating conditions. A magnetoresistor (or Hall-effect) probe, placed in a recess in the contact end of the relay core, senses a

Source: D. Q. Krebs of The Boeing Co. under contract to Marshall Space Flight Center (MFS-1754)

Circle 2 on Reader Service Card.

SEMICONDUCTOR DEVICES CAN BE TESTED WITHOUT REMOVAL FROM CIRCUIT

The test circuit shown in Figure 1A can be used for checking semiconductor device properties with the device soldered in place. The operating

shown in Figure 1B. A nominal degree of familiarity with the ideal waveforms is required for the proper interpretation of the waveforms obtained.

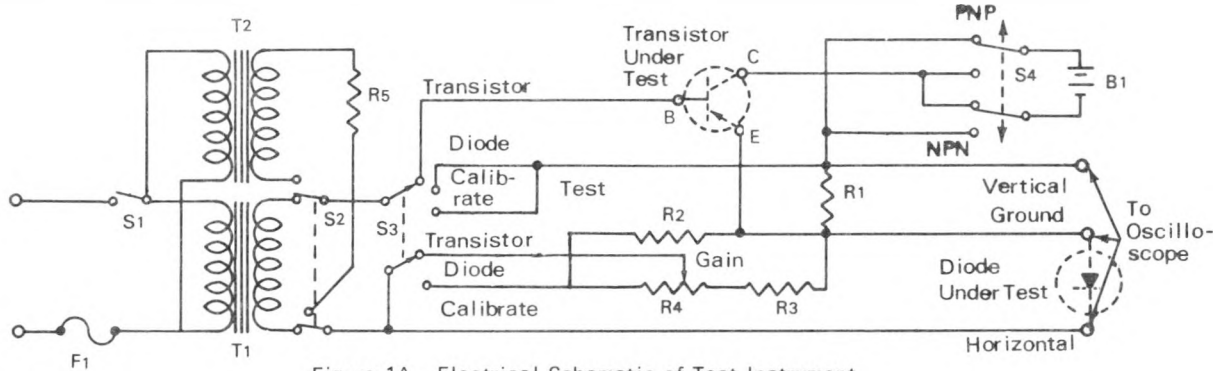

Figure 1A. Electrical Schematic of Test Instrument

At 45°
Beta is 10 if R4 is at 0

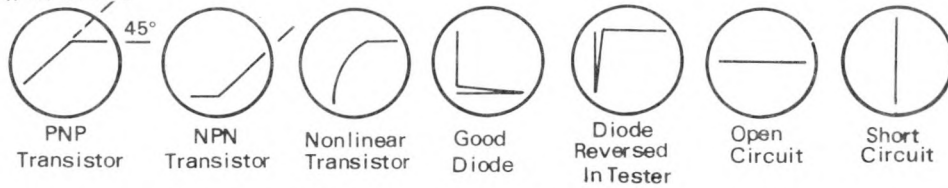

Figure 1B. Typical Waveforms of Devices Undergoing Test

characteristics are obtained by applying ac voltages from T1 and T2 and the dc collector bias voltages from B1. With the proper adjustment and calibration of the test circuit parameters, approximate values of current gain and backward and forward resistances can be obtained. Typical waveforms taken from the oscilloscope are

Source: B. C. Allen of North American Rockwell Corp. under contract to Marshall Space Flight Center (MFS-1163)

No further documentation is available.

NOVEL CIRCUIT EXTENDS USEFULNESS OF CLIP-ON AMMETER

A multiple range clip-on ammeter with a conventional left-hand zero and a 300 mA range has been converted to a zero-center milliammeter with a ± 150 mA dc range. The device is bidirectional, without reversing the input connections, and it eliminates the problems of off-scale readings and loss of real-time data.

The measurement circuit contains a separate regulated power supply with a loop of wire from the plus to the minus terminal. A clip-on ammeter probe is attached to the loop and the current flow is adjusted to provide a center-scale

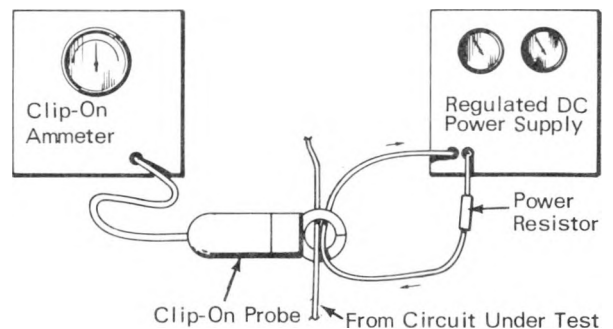

reading. Temporary scale markings of +150, 0, and -150 mA are placed on the meter face. A wire carrying current from the test circuit is also fed through the clip-on probe. With this setup, current readings from zero to ±150 mA can be taken without reversing the ammeter connections.

Source: T. J. Vaughn of North American Rockwell Corp. under contract to Manned Spacecraft Center (MSC-15851)

No further documentation is available.

CHATTER DETECTOR WITH 1 μSEC RESPONSE SENSITIVITY

This circuit can be used to sense chatter or an open circuit condition of a relay undergoing vibration, shock, or other environmental tests.

until the reset switch is actuated. Reset is possible only if continuity is present at the input. If the discontinuity is not present for the required

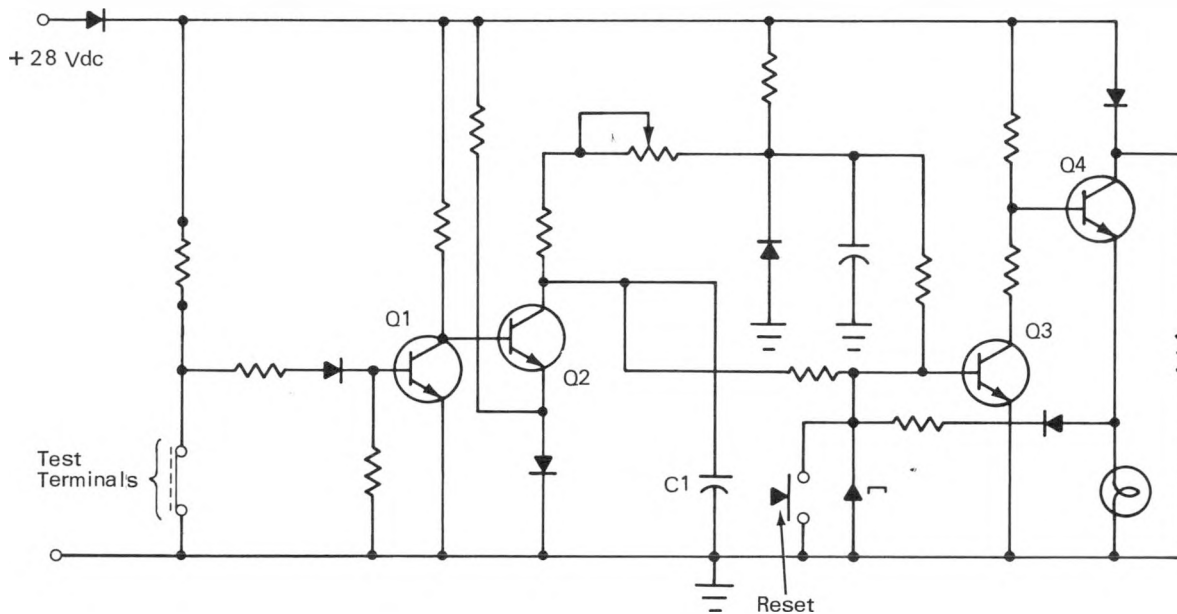

With continuity established between the test terminals, transistors Q1, Q3, and Q4 are non-conducting, while Q2 is saturated. When a discontinuity occurs, timing capacitor C1 begins to charge through the resistor network. If the discontinuity exists for a specified time, the tunnel diode switches to the high voltage point, transferring the available drive current to Q3. Latchup occurs, and the circuit remains in this condition

actuation time, the timing capacitor voltage is quickly discharged by Q2, thus preparing the circuit for the next discontinuity cycle.

Source: T. C. Marshall and E. M. Turnbow of North American Rockwell Corp. under contract to Manned Spacecraft Center (MSC-15503)

Circle 3 on Reader Service Card.

Section 2. Instrument and System Test

FREQUENCY AND VOLTAGE SENSOR CIRCUIT

The frequency and voltage amplitude sensing device shown in the figure is an integrator which can be used in a wide variety of frequency control problems. A typical application would be the sens-



ing of changes in a clock frequency of 120 kHz. Basic components of the sensor include a threshold-level integrator, a half-wave integrator and a Schmitt trigger which functions as a dc level detector.

A symmetrical square wave, ranging from 0 to -6 V, is integrated and averaged, and the dc equivalent level is used to activate a Schmitt trigger circuit. The output of the Schmitt trigger is amplified to provide a 15 mA signal in the GO state and about 90 mA in the NO-GO

state. The sensing circuit provides a false output when both the input voltage amplitude and the frequency are within the proper limits. A true output condition exists if either the frequency or

the amplitude has dropped below 120 ± 10 kHz or 4.0 ± 0.4 Vdc, respectively. By using additional flip-flops on the input to the sensor, the circuit could monitor multiples of the 120 kHz range.

Source: O. Ernst of North American Rockwell Corp. under contract to Marshall Space Flight Center (MFS-12305)

Circle 4 on Reader Service Card.

AUTOMATED VERIFIER UNIT FOR COMPUTER CARD PUNCH EQUIPMENT

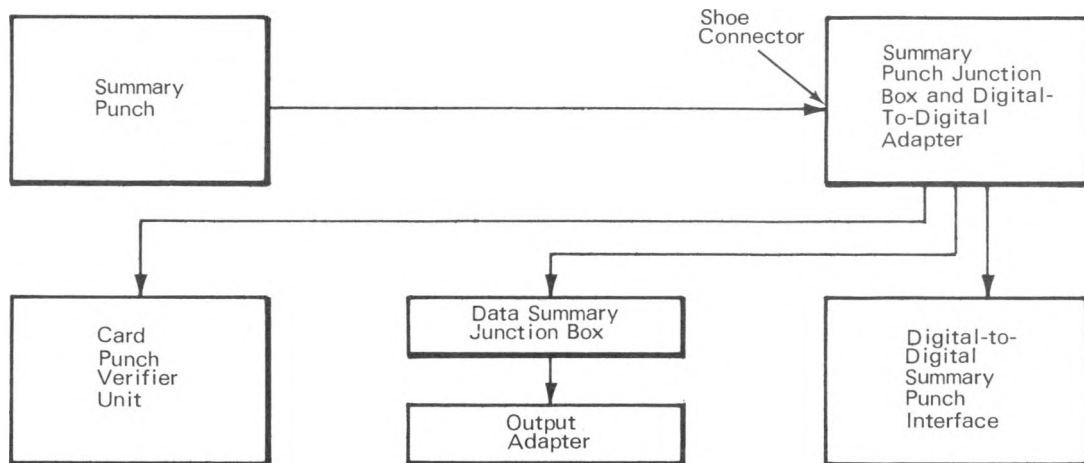

An automated verifier unit checks for errors punched in data processing cards. The unit is readily adaptable to a variety of commercially available verifiers. For large card processing

runs, it eliminates manual verifications and man-made decisions.

The operational flow diagram is shown in the figure. When data are missing between the meas-

uring and recording devices, the card punch will not advance until data become available or the card is manually released. This makes the unit compatible with external punch programming and manual operations, with slight modifications.

Source: N. E. Donlin of
The Boeing Co.
under contract to
Marshall Space Flight Center
(MFS-13719)

Circle 5 on Reader Service Card.

PCM SYNC-LOSS INDICATOR

The PCM sync-loss indicator can be used to monitor the quality of data received at ground stations.

The sync-loss detector receives the input signal, (-6 V for a sync lock, and 0 V (or ground) for a sync loss) from each PCM ground station. This signal is used to trigger a latching relay and lamp circuit for each station. The signals are also gated to an audio oscillator and speaker circuit so that, if any station drops sync, the 0-V signal will turn on the oscillator to provide an audible warning tone. In the circuit illustrated (two input sections are shown), a capacitor is discharged to turn on the silicon controlled rectifier, which in turn activates the warning light. At the same time, a transistor switch closes the ground path of the oscillator which supplies the audio input to the speaker.

Source: R. D. Patterson of
Philco-Ford Corp.
under contract to
Manned Spacecraft Center
(MSC-12342)

Circle 6 on Reader Service Card.

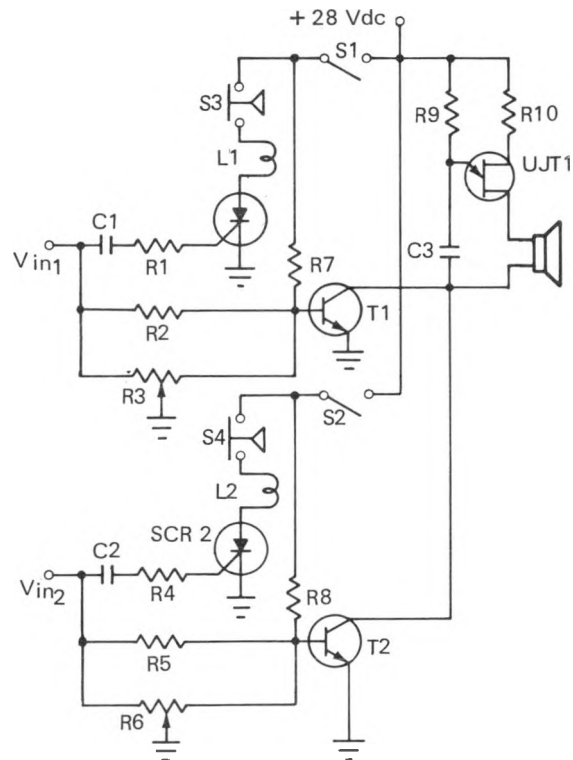

RECORDING SYSTEM MEASURES POWER TRANSIENTS

A transient recording system, with a video recorder as the basic element, detects the presence of power transients and marks their location on magnetic tape for data recovery. The system also adjusts the amplitude range of the input signals to a range within the limits of the input circuitry. An audio preamplifier and mixer are included to allow oral identification information to be recorded simultaneously with the transients.

The video recorder (see fig.) has a frequency response from 10 Hz to 3 MHz and is designed to record a 1-V peak-to-peak video signal. A signal conditioner reduces the input transients to less than the 1-V peak-to-peak level and transforms the $75\ \Omega$ input impedance of the recorder to approximately $2\ \text{M}\Omega$ to prevent overloading of the test circuit. The transient detector senses the presence of any transients exceeding a calibrated threshold and generates a short dura-

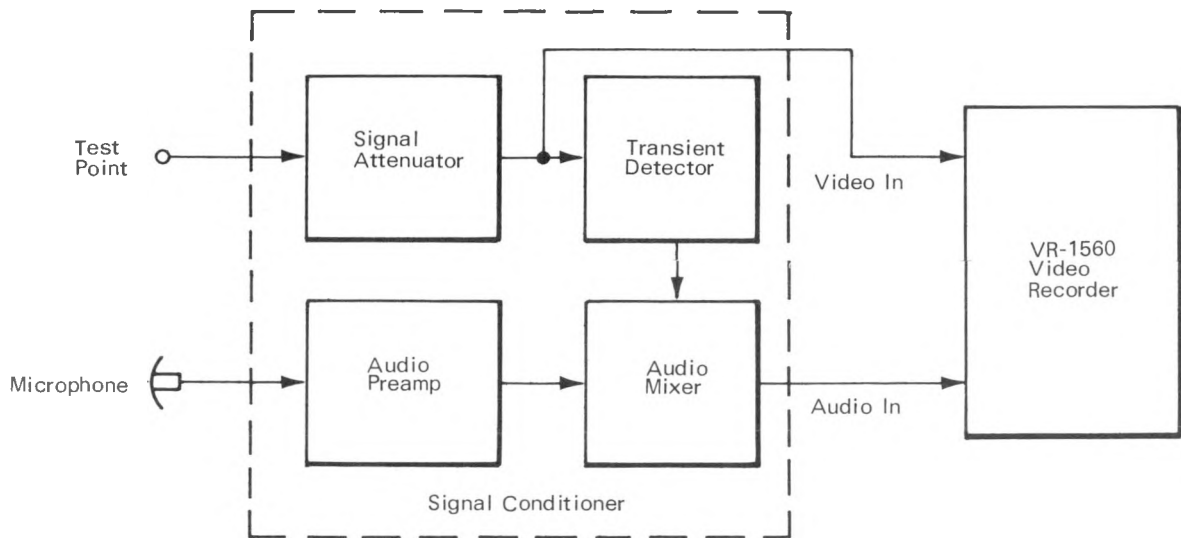

tion audio tone. This audio tone is recorded on the audio track to provide a reference point for locating the transient during playback.

The audio preamplifier raises the output of the microphone to the proper mixer input level. The mixer then combines the outputs of the transient detector and the audio preamplifier,

and this signal is recorded on the audio channel of the video recorder.

Source: J. T. Denson of
Sperry Rand Corp.
under contract to
Marshall Space Flight Center
(MFS-21103)

No further documentation is available.

TESTER PERIODICALLY REGISTERS DC AMPLIFIER CHARACTERISTICS

A motor-driven switch and a recorder (see fig.) periodically measure the gain and zero drift characteristics of a dc amplifier during environmental testing.

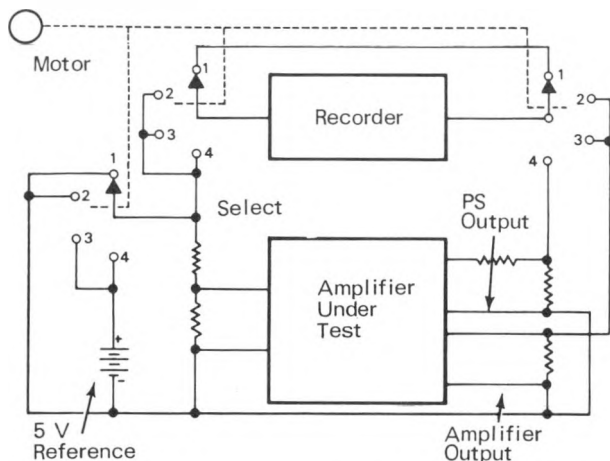

The motor drives the switch at a selected rate of one rpm. In position 1, the recorder input terminals are shorted to verify that the recorder zero has not changed. In position 2, with no input signal, the recorder registers the amplifier zero drift. In position 3, with a 5-V signal applied to a voltage divider, the amplifier output voltage recorder registers the zero drift and the gain drift. In position 4, the power supply is connected to the reference, and the test setup records one-half of the power supply drift. Several measurements can be time-shared on a single recorder trace.

Source: G. E. Wenzel and D. Cree
Manned Spacecraft Center
(MSC-190)

Circle 7 on Reader Service Card.

VARIABLE LOAD AUTOMATICALLY TESTS DC POWER SUPPLIES

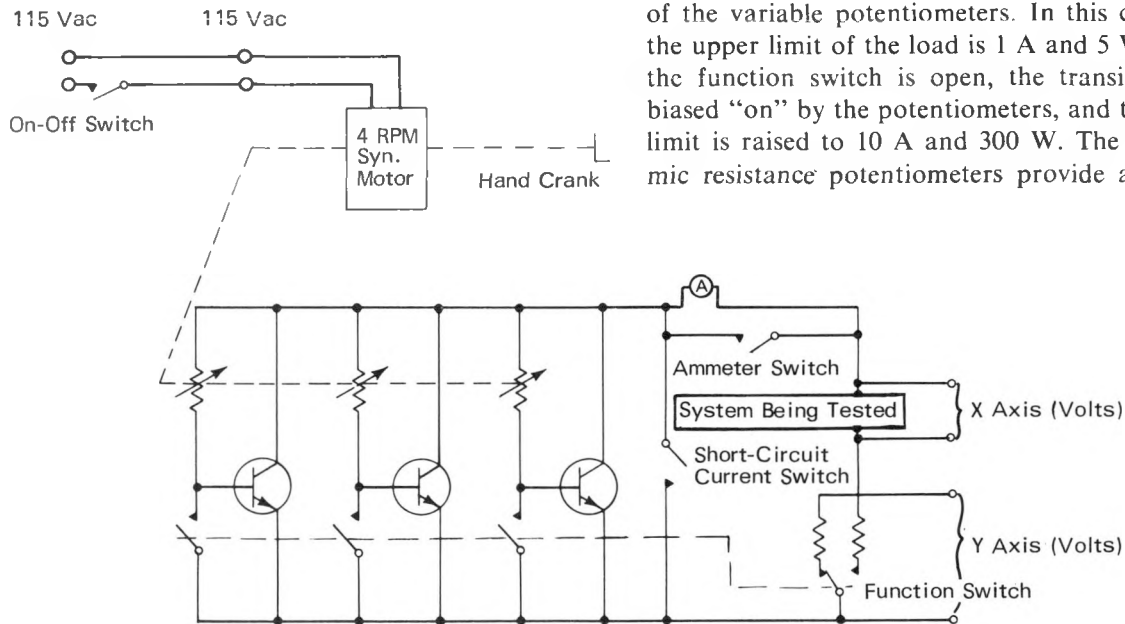

of the variable potentiometers. In this condition the upper limit of the load is 1 A and 5 W. When the function switch is open, the transistors are biased "on" by the potentiometers, and the upper limit is raised to 10 A and 300 W. The logarithmic resistance potentiometers provide a smooth

The power characteristics of low voltage, high current, dc power supplies can be measured and plotted with the circuit shown in the figure. The circuit uses three, ganged, logarithmic potentiometers driven by a self-reversing synchronous motor. When the function switch is closed, the emitter circuits of the three transistors are shorted, and the load consists of the parallel resistances

transition from an open circuit to a short circuit condition. The hand crank can be used to vary the potentiometer settings manually whenever automatic operation is not desirable.

Source: H. C. Burke, Jr., and R. M. Sullivan
Goddard Space Flight Center
(GSC-291)

No further documentation is available.

ELECTRONIC RIPPLE INDICATOR

An electronic circuit for monitoring excessive ripple voltage on dc power lines can sense variations from a few millivolts to a maximum of 10V (rms). The instrument could be used wherever

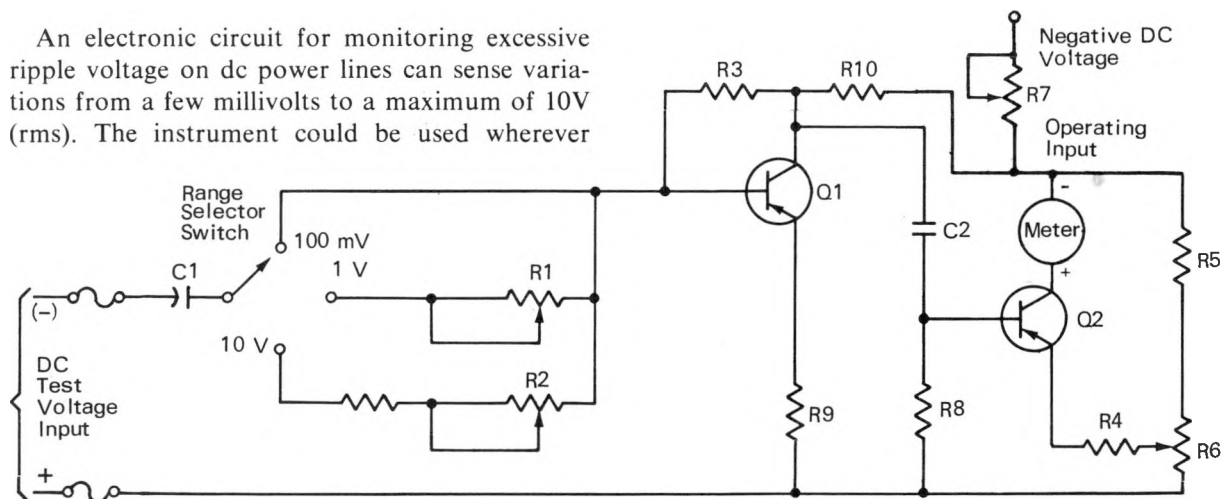

power supply fluctuations might endanger system operations or damage equipment.

The indicator includes a self-contained dc power supply, input amplifier stage, and a bridge-type balance circuit which responds to variations in the ripple voltage. A voltmeter connected across the bridge circuit measures the magnitude of the ripple.

Resistor R7 can be adjusted to set the maximum voltage level, and R6 adjusted to zero the meter.

A known magnitude of ripple voltage is required for calibration and adjustment of the ripple sensing circuit. The entire device is inexpensive and is easily packaged in a small chassis.

Source: W. H. Houck and J. K. Davidson
Kennedy Space Center
(KSC-10162)

Circle 8 on Reader Service Card.

ELECTRONIC TEST DEVICE SENSES MALFUNCTIONS IN TEST INSTRUMENTATION

The electronic test device shown in the figure is used in the test and checkout of complex systems to differentiate between malfunctions in the system undergoing test and those within the

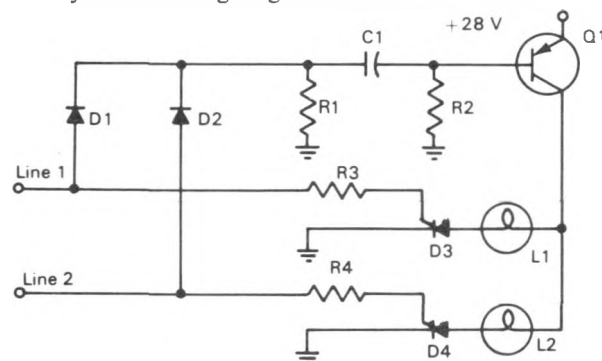

test instrumentation itself. The origin of the malfunction is quickly isolated. Electronic circuits in the monitor use transistors to commutate silicon controlled rectifiers by removing the drive voltage; display circuits are then used to monitor multiple discrete lines.

All monitored lines are connected to the "OR"

circuit composed of D1, D2, and R1. This circuit detects the presence of pulses on the lines. A composite pulse is passed to the differentiation elements C1 and R2, which form a narrow positive pulse. This pulse turns off the commutation transistor Q1 that commutates the silicon controlled rectifiers D3 and D4, causing them to reset. The leading edge of the incoming pulse is used to reset the rectifiers, and the remaining period of the pulse fires the rectifiers on those lines carrying pulses. The conducting rectifiers enable the appropriate lamp to light, indicating the origin of the malfunction. At least twenty lines can be connected to the monitoring circuit, provided that no more than twenty lamps are lighted at the same time.

Source: W. M. Miller, Jr., of
The Boeing Co.
under contract to
Kennedy Space Center
(KSC-10209)

Circle 9 on Reader Service Card.

Section 3. Calibration and Reference Circuits

PRECISION CALIBRATION AND REFERENCE VOLTAGE SOURCE FOR DATA ACQUISITION SYSTEMS

A precision calibration and reference voltage source for digital data systems dissipates less than 10 mW of power and operates continuously for extended periods of time. The hybrid in-

tegrated circuit of the source shown in the figure contains two monolithic operational amplifiers, A1 and A2, assembled on an alumina substrate. Positive feedback with a loop gain of less than

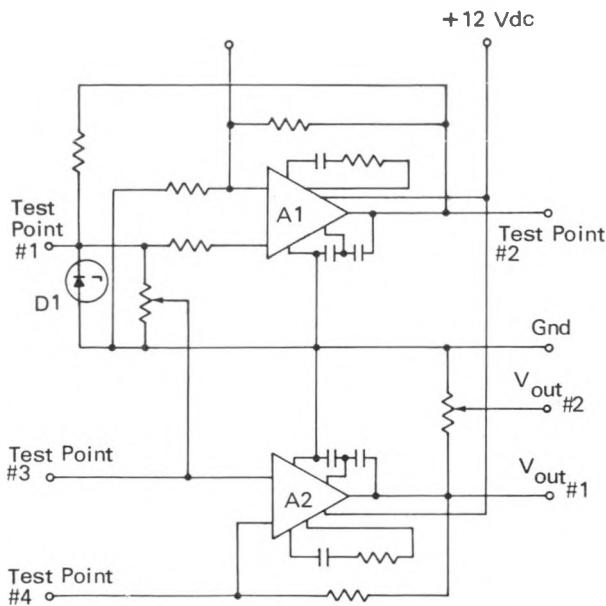

one is incorporated around A1 to constant-current bias the low-current zener diode D1. This feedback effectively isolates the positive 12 Vdc supply and prevents input voltage fluctuations

from affecting the current through D1. Amplifier A2 buffers the output circuit, prevents loading of the zener, and provides current drive capability. The gain of A1 is adjusted to ensure that the amplifier remains in its active region. Also, proper compensation is used to ensure that a 6 dB/octave rolloff is maintained through unity gain. Output #1 is the reference voltage for data acquisition and output #2 provides the calibration signal.

The low-power precision calibration and reference voltage source operates with an error of less than 0.1%, and has excellent line regulation properties. The output noise is less than 1.5 mV rms at 100 kHz. Loading effects are negligible, as evidenced by the capability of the output voltage to drive a 1 kΩ load with no nonlinearity errors.

Source: General Instrument Corp.
under contract to
Marshall Space Flight Center
(MFS-20950)

Circle 10 on Reader Service Card.

RASTER LINEARITY OF VIDEO CAMERAS CALIBRATED WITH PRECISION TESTER

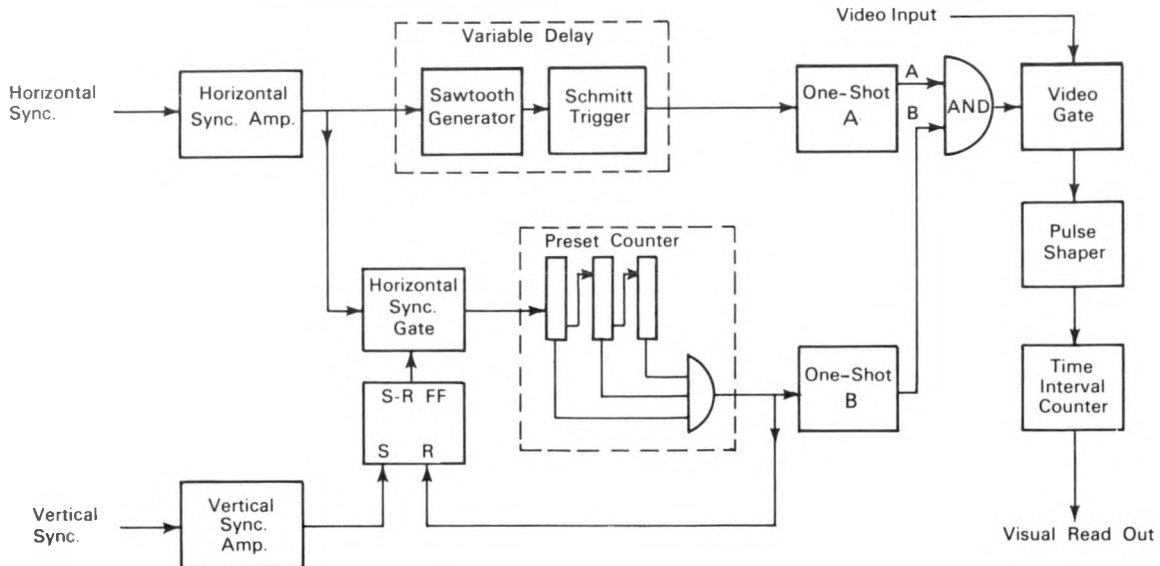

A precision test system (see fig.) calibrates the raster linearity of vidicon television-camera tubes to within 0.5%. The setup can also be used in conjunction with a camera and oscilloscope

to measure gray-scale response, resolution, and shading.

The calibration technique is based upon measuring the time between video camera output

transitions as registered at reticle marks on the vidicon faceplate. A flat white field is used as the input image to the vidicon for horizontal linearity measurements. As the vidicon beam passes the vertical reticle line, a pulse appears in the video output. When the beam traverses the second reticle line, a second pulse is generated; the counter measures the interval between these pulses.

For vertical linearity measurement, a much shorter portion of a number of horizontal raster lines is selected. Ideally, a black pulse is generated for only those video lines that traverse the horizontal portion of the desired pair of

reticles and only for the sample period. Input A, generated by the one-shot flip-flop A, provides the proper gate pulse time, approximately equal to one fourth of a TV line time. The trigger is derived from delayed horizontal sync. Input B, generated by the one-shot flip-flop B, provides the gate pulse time, equal to one horizontal line time.

Source: Radio Corp. of America
under contract to
Goddard Space Flight Center
(GSC-200)

No further documentation is available.

LOW VALUE RESISTORS AND SHUNTS CALIBRATED WITH MODIFIED DOUBLE BRIDGE

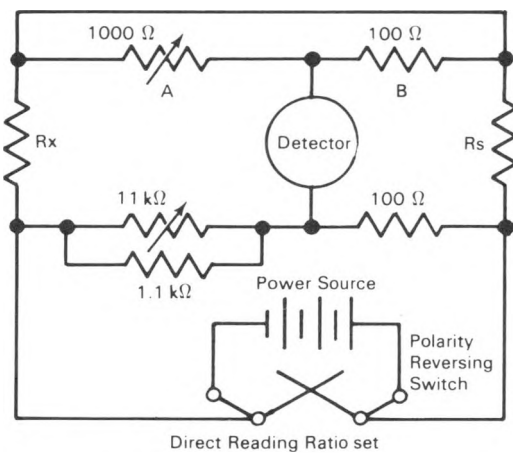

Four-terminal resistors can be tested and calibrated with a double bridge, one half of which is a direct reading ratio set (DRRS) and the second half consists of regular resistance decade boxes of nominal accuracy. After the

bridge is balanced, the ratio between the unknown resistor and the standard is read from the DRRS dials, to the precision of the DRRS.

Through the use of standard resistors, the exact ratio, including the leads to be used with the double bridge arrangement, is initially established, then balanced. The ratio of the unknown to the standard equals the ratio setting on the DRRS dials.

The instrument is simple and inexpensive and provides a straightforward measurement procedure.

Source: C. R. Miller of
The Boeing Co.
under contract to
Marshall Space Flight Center
(MFS-14104)

Circle 11 on Reader Service Card.

RADIOMETRIC TEMPERATURE REFERENCE

A radiometric temperature reference (RTR) uses a thermistor as both the heating and the sensing element to maintain its resistance at a preselected level.

The operating temperature of the RTR is controlled by varying the value of R1 at the input

of constant current amplifier #1. Amplifier #2, operating in a unity gain mode, inverts the signal polarity for positive feedback through resistor R1. When the circuit is energized, the resistance value of R1 is less than the resistance of the thermistor (T), establishing a gain greater than

unity. During this condition, the voltage across the thermistor increases until it approximates

the power supply voltage. This voltage heats the thermistor until its resistance is approximately equal to R_1 and then decreases to a value necessary for maintaining resistance equilibrium.

Source: L. G. Monford, Jr.
Manned Spacecraft Center
(MSC-13276)

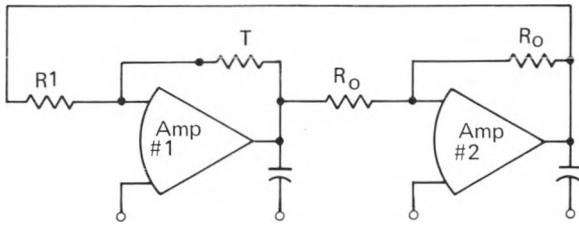

Circle 12 on Reader Service Card.

POTENTIOMETRIC SOURCE-RESISTANCE METER

This meter utilizes the simple power-detecting characteristic of ganged, unloaded potentiometers to determine the source-resistance of a generator in the dc to UHF frequency range. (With appropriately scaled resistance and power dissipation capabilities of the potentiometers, the

device can determine the internal resistance of electric cells and batteries in order to estimate the state of discharge and the remaining useful life.) A typical application of the meter is shown in the figure.

seen by the voltmeter-detector is a maximum of 1.3 k Ω . The meter is inherently broadband, is simple in design, and is easy to fabricate. It can determine source-resistance over a wide range of input power and is extremely simple to operate, re-

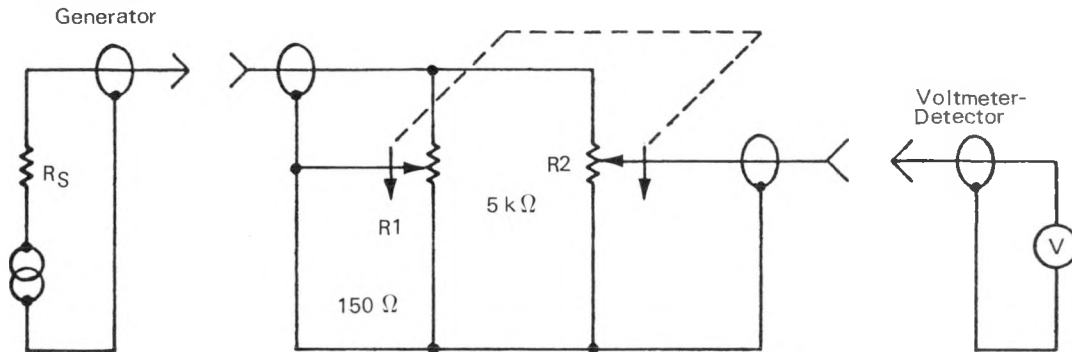

quiring only an adjust-to-peak operation, with direct readout of the resistance on a calibrated dial.

Source: E. C. Oakley of
Caltech/JPL
under contract to
NASA Pasadena Office
(NPO-10885)

The coax system has a 50 Ω operational resistance, and R_1 is 150 Ω . R_2 is 5 k Ω , which yields a 0.5% loading error in the terminated network of R_s and R_1 . The source-resistance

Circle 13 on Reader Service Card.

PRECISION BOLOMETER BRIDGE

An inexpensive precision bolometer calibration bridge has several advantages over more expensive, commercially available devices. The bridge can be manually balanced for dc bias

and balance indication, with either dc or ac power input. In each application, an external galvanometer is used for null indication. Total dc current through the bridge is measured with

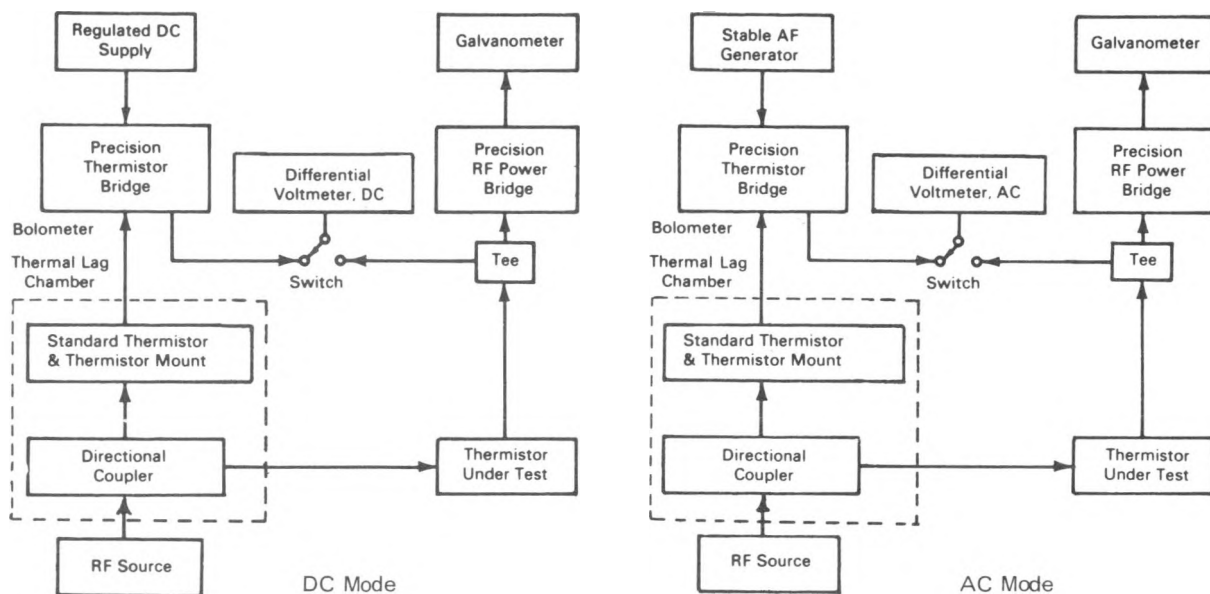

an external milliammeter, or the voltage across the bolometer may be measured when the milliammeter terminals are shorted.

In the ac mode, the bridge is capable of measuring the impedance of thin-film bolometers with a 10 kHz, 15 V signal input.

Source: D. R. White of North American Rockwell Corp. under contract to Manned Spacecraft Center (MSC-11473)

Circle 14 on Reader Service Card.

CALIBRATION OF HIGH VOLTAGE DIVIDER

A simple circuit can be used for fast, accurate in-circuit calibration of a high voltage divider, even when the divider is operated under normal current and voltage load conditions.

Resistors R1, R2, and R3 (see fig.) make up the voltage divider to be calibrated. The calibration circuit comprises a low precision resistor R4, a high precision potentiometer R5, and switches S1 and S2.

To calibrate a high voltage divider, the divider input is applied to the input terminals of the calibration circuit, S2 is moved to the "calibrate" position, S1 is moved to position 1 and potentiometer R5 is adjusted until a null is obtained on the null detector. The same procedure is followed for positions 2 and 3 of S1. The three resulting potentiometer readings (P1, P2, P3) of R5 at the null points are used to calculate the resistance of the divider network.

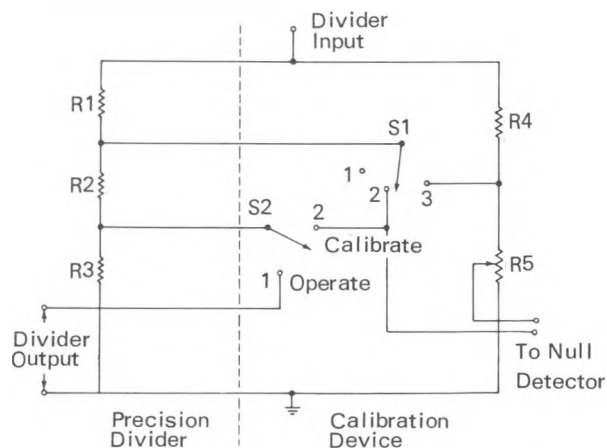

Source: R. N. Lewis Argonne National Laboratory (ARG-83)

Circle 15 on Reader Service Card.

STRAIN GAGE TRANSDUCER BRIDGE CALIBRATED REMOTELY

A special circuit (see fig.) similar to a Wheatstone bridge allows remote electrical calibration of a strain gage transducer using a constant current supply. Two resistors in the

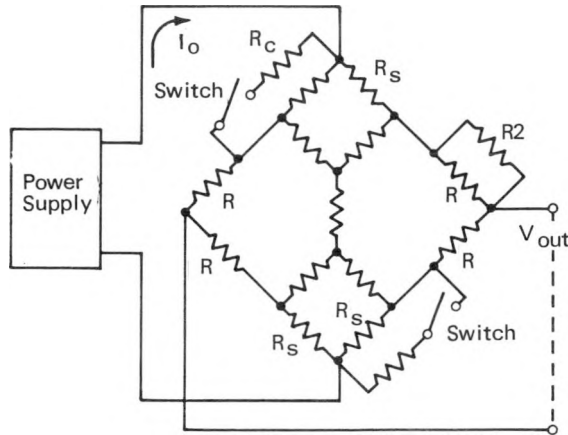

bridge circuit are shunted by a remotely located two-pole switch. This unbalances the bridge and provides an output voltage offset which serves as the calibration voltage. During normal operation of the transducer, the bridge is in

balance unless there is a measurable input (force, pressure, etc.). Such an input unbalances the bridge, to produce an output voltage proportional to the value of the excitation current, I_o . During this mode of operation, the circuit functions as a conventional constant-current, strain gage bridge; the resistors merely raise the bridge impedance slightly. Typical values of R_s would be 100 Ω , compared to 400 Ω for the gage resistance.

The calibration voltage provided by the shunt resistance calibration remains constant even though the strain gages change resistance with changing temperatures. This permits the remote calibration of force, pressure, and flow transducers over a wide range of temperatures, without the need for providing special temperature compensation for the resistance calibration circuit.

Source: P. Postma of North American Rockwell Corp. under contract to Marshall Space Flight Center (MFS-18596)

Circle 16 on Reader Service Card.

Section 4. Simple Test Procedures

LOCATING SNEAK PATHS IN ELECTRICAL CIRCUITRY

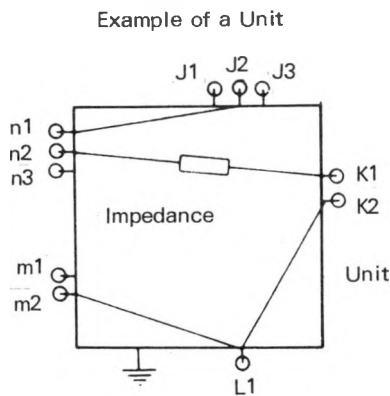

Figure 1.

A troublesome phenomenon in the operation of electrical circuitry is the existence of "sneak paths" (defined as unplanned, closed current paths) which degrade performance. These paths contain unwanted electrical currents which are almost impossible to locate. Sneak paths can be completely described, within defined limits, by circuit diagrams.

The task of segregating the paths from the normal power loops of circuit diagrams can be accomplished by direct examination with the aid of the scheme shown in the figures. The approach shown uses a matrix system wherein circuit pin-connections are assigned arbitrary designators.

The format of the matrix is a rectangular

Example of a Matrix

	J1	J2	J3	K1	K2	L1	M1	M2	N1	N2	N3
J1	1	0	0	0	0	0	0	0	0	0	0
J2	0	1	0	0	0	0	0	0	1	0	0
J3	0	0	1	0	0	0	0	0	0	0	0
K1	0	0	0	1	0	0	0	0	0	1	0
K2	0	0	0	0	1	1	0	0	0	0	0
L1	0	0	0	0	1	1	0	1	0	0	0
M1	0	0	0	0	0	0	1	0	0	0	0
M2	0	0	0	0	0	1	0	1	0	0	0
N1	0	1	0	0	0	0	0	0	1	0	0
N2	0	0	0	1	0	0	0	0	0	1	0
N3	0	0	0	0	0	0	0	0	0	0	1

Figure 2.

representation of the possible current paths through a unit. For example, to show the electrical path from pin N2 to K1, place the numeral "1" in the K1 column and N2 row. This "1" entry indicates a conducting path from N2 to K1 or from K1 to N2, according to the above definition of current paths. In noting the direction of current flow, N2K1 represents positive current flow (opposite electron flow) from N2 to K1. Various types of impedances can be listed in the matrix by replacing the 1 with the appropriate code number or letter.

Source: T. M. Dannback of
The Boeing Co.
under contract to
Marshall Space Flight Center
(MFS-15018)

Circle 17 on Reader Service Card.

COLOR IDENTIFICATION TESTING DEVICE

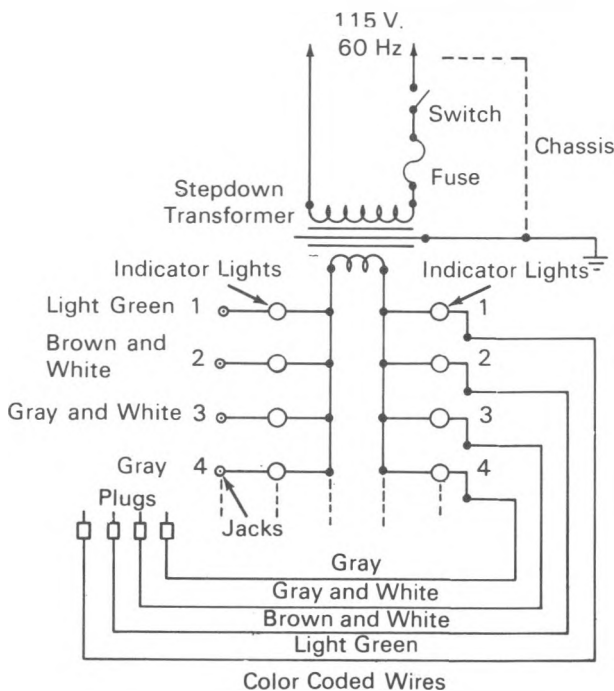

A device for testing color blindness aids in determining the ability of a technician to identify color-coded electrical wires. The device can test

the speed of wire selection, as well as the selection accuracy, under conditions similar to those encountered on the job. Certain types of partial color blindness which are often missed by standard tests and which produce errors in color-code determination can also be detected.

Each loop of the low-voltage test circuit contains two lamps, a color-coded wire attached to a male connector plug, and a female connector jack. The jacks are mounted on a panel and labeled with the name of the correct color code. The two lamps for each circuit are paired, either adjacent to the jacks or on a separate panel which may be placed so that the examinee cannot see the results of his selections.

A correct choice will light two adjacent lamps, and an incorrect choice will light bulbs in two different rows.

Source: R. Martin, E. Brawner, and W. Pate of
The Bendix Corp.
under contract to
Kennedy Space Center
(KSC-10278)

Circle 18 on Reader Service Card.

PHASE DETECTOR ENSURES PROPER PHASING IN POWER CIRCUITS

During the initial application of power to an electrical system, the phasing of the line voltages must be tested to eliminate potentially hazardous conditions and avoid possible equipment damage.

output from the phase shifting and summing network passes through a transformer and is rectified and filtered. The resulting dc voltage operates a Schmitt trigger which drives the output stage.

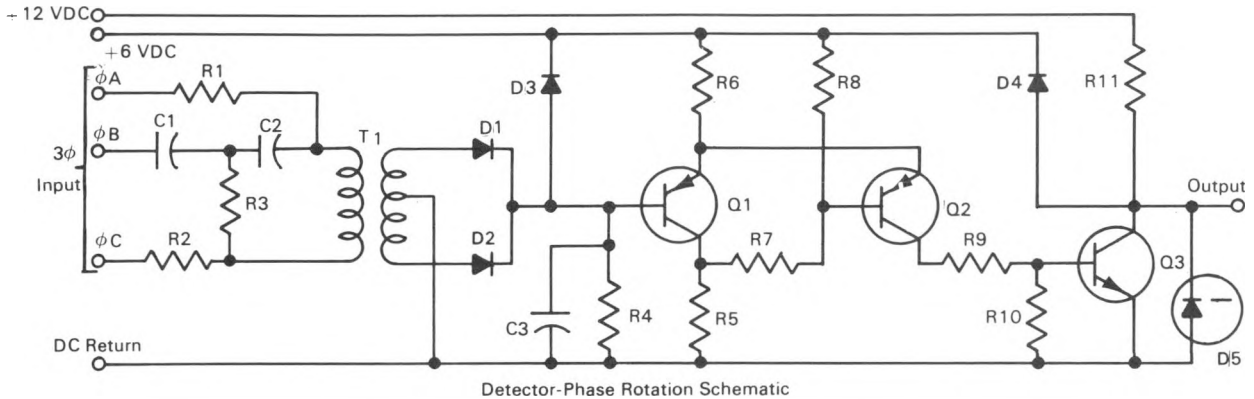

The phase rotation detector can be used to detect phase rotation in any three-phase power circuit. The detector consumes a nominal amount of power and can be fabricated by using high density packaging methods. The device produces a 6 Vdc or 0 Vdc output indicating a phase rotation of ACB or ABC, respectively, of the three-phase lines (see fig.). The 3-phase, 400 Hz input is phase shifted and summed in the input circuitry, producing no output if rotation is ACB and a positive voltage if rotation is ABC. The

The important features of the detector are its small size, high input/output isolation (greater than 100 M Ω), and high input and output impedances.

Source: C. J. Rogers and J. R. Lorchik of North American Rockwell Corp. under contract to Manned Spacecraft Center (MSC-11855)

Circle 19 on Reader Service Card.

ELECTRICAL CONTINUITY SCANNER IDENTIFIES CONNECTOR WIRES

The electrical continuity scanner shown in the schematic is ideal for the production line testing of prefabricated cables for large complex electrical systems. In the test line operation, one known point is electrically connected by a temporary jumper wire to the common post of the electrical continuity scanner.

Actuation of the switch to the search position causes the rotary relays to step or search until either a circuit having electrical continuity is reached or the search switch is released. This automatic stepping is accomplished through the use of contacts provided on the automatic electric relay (R1) to make it free running when

desired. After 10 wires have been scanned, a second automatic electric relay (R2) is actuated through one position by a latching relay (L1) that transfers the test set to the next 10 circuits. In this manner, 5 decks with 10 positions can be used to scan 50 circuits in a fully automatic or free running mode.

If a continuity occurs, a relay is energized to prevent further search, and a lamp is lit to indicate the number of the post providing continuity. The search switch is then released, and the known endpoint and the post number providing continuity are recorded. The jumper wire is moved to the next known point and the search

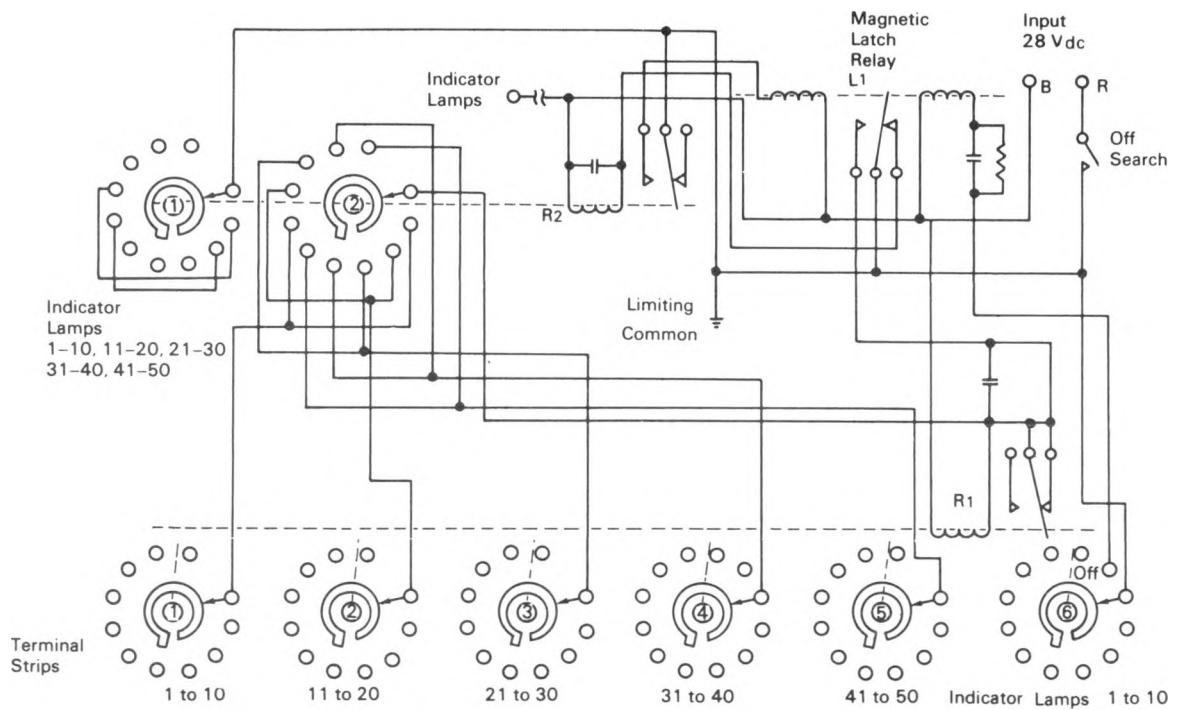

procedure is repeated until all wires in the bundle have been correlated with their respective known ends.

Modifications can be made to the basic plan to provide circuitry for scanning up to 250 wires. The scanner can also be used to minimize termination errors in the rapid fabrication of multi-wire electrical cables.

Source: R. A. Diclemente and H. C. Boulton of North American Rockwell Corp. under contract to Manned Spacecraft Center (MSC-90626)

Circle 20 on Reader Service Card.

SAFETY CIRCUIT SENSES FUEL IGNITION

A high-response photosensor, integrated into a solid state switching circuit, provides an output signal which confirms whether the combustion of prepellants has occurred in rocket motor tests. This indication eliminates potential hazards due to the accumulation of unreacted propellents prior to ignition.

Upon sensing the ignition light, the circuit energizes a latch relay, allowing the flow of fuel to continue if the ignition is established within a predetermined sampling time. The sensor circuit has application in oil-burning furnaces, boiler purge systems, power generation stations, and other areas where fuel ignition is an important operating parameter.

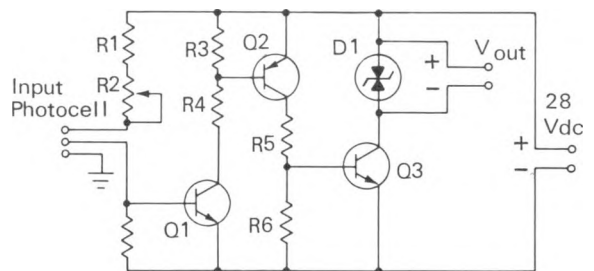

Source: J. D. Gillett of North American Rockwell Corp. under contract to Marshall Space Flight Center (MFS-91892)

Circle 21 on Reader Service Card.

DETECTOR CIRCUIT MEASURES RELAY CHATTER DURATION

A highly accurate chatter detector indicates the presence and the duration of contact chatter. The detector unit, constructed almost entirely of integrated circuits, is ideal for miniaturiza-

The oscillator (excluding the crystal), gate, counters, coincidence detector, and lamp driver are integrated circuits requiring only a minimum of discrete components. The range of the detector

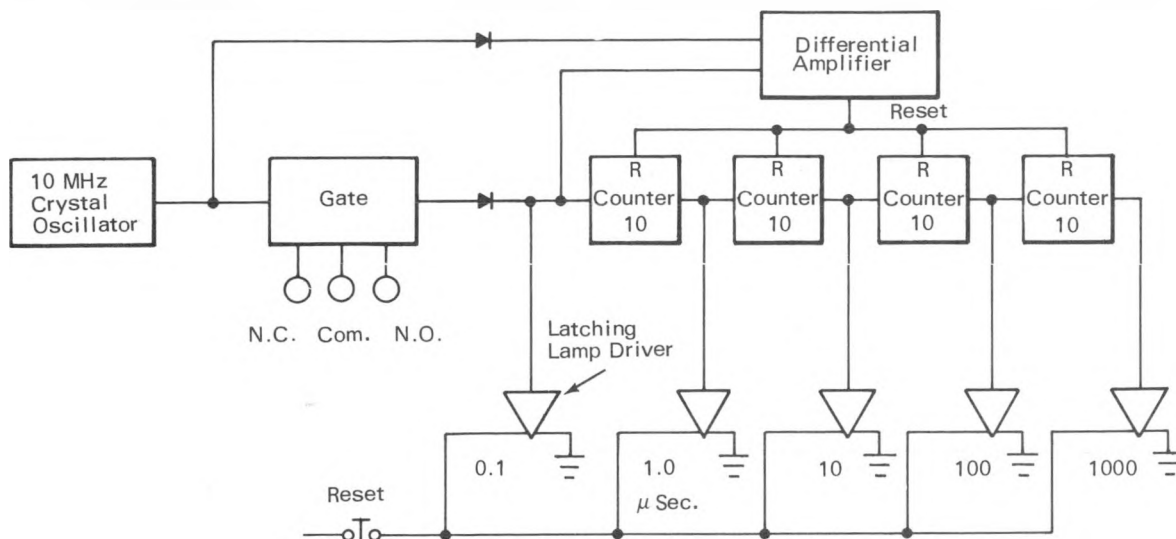

tion. Important operational features include complete versatility in range selection, with no sacrifice in accuracy, and virtual elimination of periodic recalibration. The chatter detector utilizes the principle of pulse counting to determine the chatter interval. The pulses are generated by a crystal-controlled oscillator and are counted by a series of decade counters. The inherent stability and accuracy of the crystal oscillator eliminates the need for periodic calibration and adjustment.

can be changed by switching crystals and/or using decade, octal, or binary counters. Since each counter output has a lamp, the duration of chatter is bracketed between the two highest illuminated lamps.

Source: L. A. Updegraff of
North American Rockwell Corp.
under contract to
Manned Spacecraft Center
(MSC-15799)

No further documentation is available.

HELIUM BACKGROUND SUPPRESSOR CIRCUIT IMPROVES SENSITIVITY OF LEAK DETECTOR

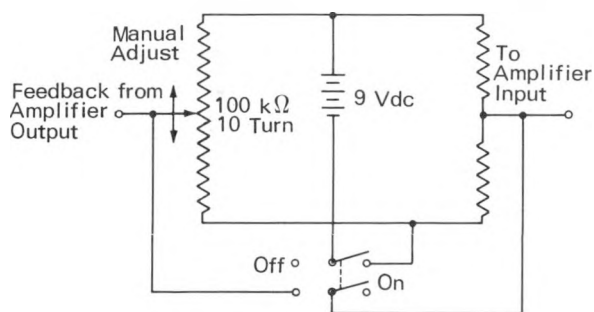

A feedback circuit packaged in a separate unit permits the manual adjustment of the zero reference in a mass spectrometer leak detector. This correction eliminates the helium background which normally would reduce the sensitivity of the instrument. Amplifier linearity and gain factors are not affected as is the case with conventional leak detectors.

The suppressor circuit can be used in leak detection applications where high but stable helium

backgrounds may be encountered, such as in small test cells.

The operation of the suppressor is as follows: If the helium background is high enough to warrant use of the suppressor, the suppressor is turned on. The suppressor control is adjusted to reduce the background level indication until

the system is operating on the range of highest permissible sensitivity requirements.

Source: J. J. Walls, Jr., and J. F. Ply of North American Rockwell Corp. under contract to Manned Spacecraft Center (MSC-17210)

Circle 22 on Reader Service Card.

ELECTRONIC CLAMP CIRCUIT IMPROVES PERFORMANCE OF ULTRASONIC TRANSDUCER

This electronic clamp circuit improves the performance of ultrasonic inspection equipment and simplifies the detection of structural flaws or defects which are located in close proximity

sitivity of the crystal to be utilized. The clamping action stops the electrical oscillations of the crystal tuning circuit immediately following the excitation pulse and permits the receiver to pick

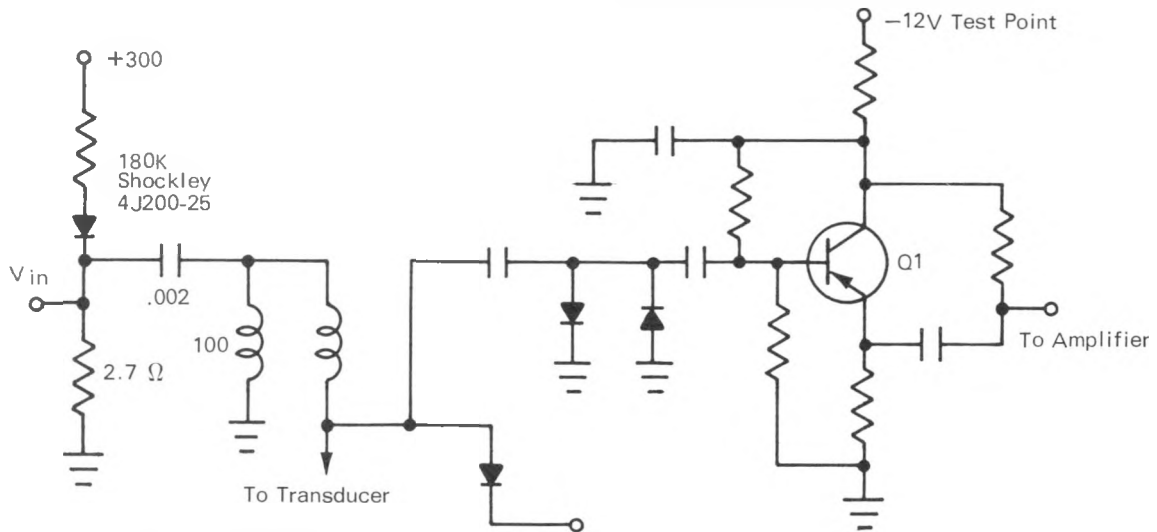

to the transducer. Conventional ultrasonic test instruments employing pulse echo techniques encounter excessive ringing of the crystal tuning circuit due to the excitation pulse, and this ringing obscures the received echo.

The clamp circuit is synchronized with the excitation pulse to short out the crystal tuning circuit for a brief period after the excitation pulse. It then unclamps, permitting the full sen-

sitivity of the crystal to be utilized. The clamping action stops the electrical oscillations of the crystal tuning circuit immediately following the excitation pulse and permits the receiver to pick

Source: D. C. Erdman of North American Rockwell Corp. under contract to Marshall Space Flight Center (MFS-11217)

Circle 23 on Reader Service Card.