

2/00/1

4E-38

34

NASA SP-5952(02)

TECHNOLOGY UTILIZATION

TESTING METHODS AND TECHNIQUES:  
QUALITY CONTROL AND NONDESTRUCTIVE  
TESTING

A COMPILATION



NATIONAL AERONAUTICS AND SPACE ADMINISTRATION

**MASTER**

DISTRIBUTION OF THIS DOCUMENT IS UNLIMITED

## **DISCLAIMER**

**This report was prepared as an account of work sponsored by an agency of the United States Government. Neither the United States Government nor any agency thereof, nor any of their employees, makes any warranty, express or implied, or assumes any legal liability or responsibility for the accuracy, completeness, or usefulness of any information, apparatus, product, or process disclosed, or represents that its use would not infringe privately owned rights. Reference herein to any specific commercial product, process, or service by trade name, trademark, manufacturer, or otherwise does not necessarily constitute or imply its endorsement, recommendation, or favoring by the United States Government or any agency thereof. The views and opinions of authors expressed herein do not necessarily state or reflect those of the United States Government or any agency thereof.**

---

## **DISCLAIMER**

**Portions of this document may be illegible in electronic image products. Images are produced from the best available original document.**

# Foreword

The National Aeronautics and Space Administration and the Atomic Energy Commission have established a Technology Utilization Program for the rapid dissemination of information on technological developments which have potential utility outside the aerospace and nuclear communities. By encouraging multiple application of the results of their research and development, NASA and AEC earn for the public an increased return on the investment in aerospace and nuclear research and development programs.

The items in this compilation describe a variety of devices and techniques useful in nondestructive testing. Ranging in complexity from an automated ultrasonic testing system designed for inspecting complex laminated honeycomb structures, to a flexible leak detector probe, the items represent either potential savings in cost and time, or improvement in inspection quality over past techniques. The items are presented in three sections, dealing with weld and braze inspection, leak detection, and inspection of composite materials. A preceding volume in this series, NASA SP-5952(01), dealt with physical inspection and with the detection of internal flaws.

Readers interested in other fields of testing may refer to NASA SP's 5943, 5944, and 5945, which treat, respectively, the testing of electrical and electronic devices, strength of materials, and environmental testing.

Additional technical information on individual devices and techniques can be requested by circling the appropriate number on the Reader Service Card enclosed in this compilation.

Unless otherwise stated, NASA and AEC contemplate no patent action on the Technology described.

We appreciate comment by readers and welcome hearing about the relevance and utility of the information in this compilation.

Jeffrey T. Hamilton, Director  
Technology Utilization Office  
National Aeronautics and Space Administration

NOTICE • This document was prepared under the sponsorship of the National Aeronautics and Space Administration. Neither the United States Government nor any person acting on behalf of the United States Government assumes any liability resulting from the use of the information contained in this document, or warrants that such use will be free from privately owned rights.

For sale by the National Technical Information Service, Springfield, Virginia 22151.

## NOTICE

This report was prepared as an account of work sponsored by the United States Government. Neither the United States nor the United States Atomic Energy Commission, nor any of their employees, nor any of their contractors, subcontractors, or their employees, makes any warranty, express or implied, or assumes any legal liability or responsibility for the accuracy, completeness or usefulness of any information, apparatus, product or process disclosed, or represents that its use would not infringe privately owned rights.

**MASTER**

DISTRIBUTION OF THIS DOCUMENT IS UNLIMITED

## Contents

	Page
<b>SECTION 1. Weld and Braze Inspection</b>	
Water-Column Ultrasonic Probe Speeds Weld Testing . . . . .	1
Ultrasonic Inspection of Opposed-Arc Welds Detects Incomplete Penetration . . . . .	1
X-Ray Inspection During Welding of Large Assemblies . . . . .	2
Thresholds for Radiographic Detection of Aluminum Weld Defects . . . . .	2
Radiographic Inspection of Rigid Tubing Joints . . . . .	3
Ultrasonic Inspection of Thin-Walled Tubing Welds . . . . .	3
High-Precision Ultrasonic Inspection of Braze Joints . . . . .	4
Low-Energy Gamma Ray Inspection of Brazed Aluminum Joints . . . . .	5
Braze Joint Quality Tested Electromagnetically . . . . .	5
Evaluation of Braze Joint Testing Methods . . . . .	6
<b>SECTION 2. Leak Detection</b>	
Leak Locator for Vacuum-Jacketed Pipelines Eliminates Need for Removing Outer Casing . . . . .	7
Flexible Gas Leak Detector Probe . . . . .	7
Chamber Monitors Gas Leakage Through Flange Seal . . . . .	8
Leak Detection in Sealed Electrical Components . . . . .	8
Fixture for Helium-Tracer Leak Testing of Pipe Welds . . . . .	8
Helium Leak Test Envelopes for Tube Fittings . . . . .	9
Gas Leakage Rate Determined from Bubble Formations . . . . .	10
Burst-Diaphragm Leak Detector . . . . .	10
Study of Leak Tracer-Gas Diffusion . . . . .	10
Time-Exposure Photography Pinpoints Leakage Sites . . . . .	11
Dispenser Leak-Tests and Sterilizes Rubber Gloves: A Concept . . . . .	11
Detecting Holes in Thin Polymeric Films . . . . .	12
Wick Gives Convenient Leak Monitor in Foam-Insulated Region . . . . .	13
Determination of Hydrogen Leakage Through Laminated Honeycomb Material . . . . .	13

SECTION 3. Adhesive Bonding and Composite Materials Inspection	Page
Infrared Inspection of Vented Cork-on-Foam Insulation . . . . .	14
Tool for Vacuum Inspection of Bonded Cork Insulation . . . . .	14
Acoustic Inspection of Cork-on-Foam Bonded Insulation . . . . .	15
Ballpoint Probe for Ultrasonically Testing Composite Structure Bond Integrity: A Concept . . . . .	15
Ultrasonic Emission Testing of Adhesive Bonds . . . . .	16
Acoustic Determination of Adhesive Bond Strength in Honeycomb Composites . . . . .	16
Improved Ultrasonic Couplant for Inspecting Porous Materials . . . . .	17
Liquid Crystals Detect Voids in Fiberglass Laminates . . . . .	18
Polarized Light Reveals Stress in Machined, Laminated Plastics . . . . .	18
Testing the Degree of Curing in Epoxy-Impregnated Sheets . . . . .	18
Inspection of Open-Face Honeycomb Seals Using Low-Viscosity Liquids . . . . .	19
Automatic Ultrasonic Quality Inspection of Bonded Honeycomb Assemblies . . . . .	19

## Section 1. Weld and Braze Inspection

### WATER-COLUMN ULTRASONIC PROBE SPEEDS WELD TESTING

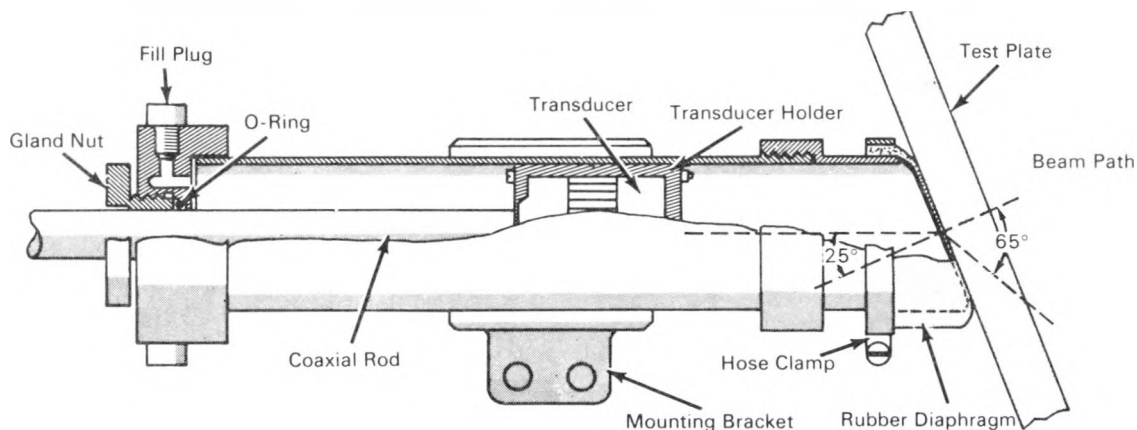

An ultrasonic device consisting of a coaxial rod and transducer enclosed in a water-filled cylindrical probe enables rapid testing of welds. The probe is coupled to the test surface by a rubber diaphragm, molded to produce the desired test beam angle. The diaphragm is flexible enough to allow full contact with slightly rough or curved surfaces, and can be moved close to a high weld bead.

The water column contains a beam transducer that can be focused at a desired depth in the material. A transducer holder acts as a spacer

and maintains the position of the transducer after setting; filler caps maintain the water level. The rubber diaphragm is the contact surface of the probe, and retains the water in the column.

Source: J. M. Hoop and J. A. McDonald of  
General Electric Co.  
under contract to  
NASA Headquarters  
(HQN-00058)

*Circle 1 on Reader Service Card.*

### ULTRASONIC INSPECTION OF OPPOSED-ARC WELDS DETECTS INCOMPLETE PENETRATION

Radiographic inspection cannot reliably detect incomplete penetration of opposed-arc weldments, but near 100% detection can be maintained by ultrasonic inspection techniques. Results of a test program indicate that ultrasound can reliably detect defects as small as one-third the ultrasonic wavelength.

Ten test specimens, deliberately miswelded to produce incomplete penetration of various thicknesses and lengths, were examined by X-ray radiographic and shear-wave ultrasonic techniques. Then the welds were sectioned and

examined metallographically. Test results in every case showed much more uniform detection of incomplete penetration by the ultrasonic technique.

Source: D. L. Norris of  
North American Rockwell Corp.  
under contract to  
Marshall Space Flight Center  
(MFS-12851)

*Circle 2 on Reader Service Card.*

### X-RAY INSPECTION DURING WELDING OF LARGE ASSEMBLIES

The technique shown in the figure was developed to permit in-process X-ray inspection of vertical welds on a large component. Using two

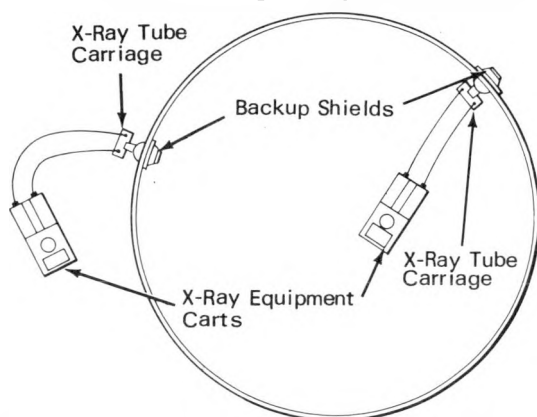

mobile X-ray units, one on either side of the component to be inspected, the technique combines special positioning features and maximum mobility with the ability to inspect weldments up to 15 cm in thickness. The technique operates with a high safety factor, requiring only a small radiation perimeter. It should prove useful in situations where the size or

shape of an item prevents it from being taken to a fixed-site X-ray machine.

The carriage on which each X-ray tube is mounted also carries a motorized platform, which enables the X-ray tube to be raised to any elevation on the test component. Further, the unit can be rotated to any position within  $\pm \pi/6$  rad ( $30^\circ$ ) of the perpendicular to the component, both by rolling the carriage from side to side and by tilting the X-ray tube itself. The equipment cart carries the associated high voltage supplies and oil-coolant circulators for the X-ray tube.

The backup lead shield for each unit is mounted on its own two-wheel carriage, and is raised and lowered by means of a hydraulic jack.

Source: G. C. Occipinti of  
 The Boeing Co.  
 under contract to  
 Marshall Space Flight Center  
 (MFS-14295)

*Circle 3 on Reader Service Card.*

### THRESHOLDS FOR RADIOGRAPHIC DETECTION OF ALUMINUM WELD DEFECTS

The fixed radiographic technique threshold for detecting surface and subsurface cracks in 0.64 cm 2014-T651 aluminum welds has been determined. Tapered slits of predetermined dimensions, used to simulate aligned weld cracks, were produced by bonding special graduated aluminum penetrameters to the centerline of a weld between a matched set of test plates. Penetrometer thicknesses of 0.002, 0.005, 0.0075, 0.010, and 0.013 cm were used to simulate crack depth. Equally thin hole-type penetrameters, containing eight holes with various diameters, were also prepared in order to determine the smallest hole image resolvable under the fixed radiographic technique. Test variables evaluated included hole and slit depth (between 0.002 and 0.013 cm), the location of the penetrometer within the test plates, and X-ray beam angle. A total of 80 radiographs were taken,

employing the same radiographic technique, equipment, and materials in all cases. The radiographic films were evaluated by five highly competent film interpreters, and the threshold detection capability of the fixed radiographic technique was defined as a function of minimum detectable width, depth, and length of the slits and the maximum radiographic sensitivity achieved for the graduated hole penetrameters.

Documentation is available from:

National Technical Information Service  
 Springfield, Virginia 22151  
 Price \$3.00  
 Reference: TSP69-10418

Source: R. W. Tryon of  
 General Dynamics  
 under contract to  
 Marshall Space Flight Center  
 (MFS-20487)

## RADIOGRAPHIC INSPECTION OF RIGID TUBING JOINTS

Two recent reports summarize some of the special procedures, standards, and equipment used in nondestructive testing of the Apollo spacecraft. Special emphasis is given to the advanced radiographic techniques used to inspect the many rigid tubing joints in the spacecraft fluid systems.

Four general types of tubing joints, and the variations in required testing techniques, are discussed. Each type of joint—brazed, welded, soldered, and salt bath brazed—employs different types of materials and is controlled by separate process and quality specifications. Discussion of this aspect of the testing problem centers on variations in the types of defects encountered, and on the specific techniques which best reveal these defects.

Another aspect of the problem is presented by the fact that many of the joints are located in areas with highly restricted access. Here the discussion shifts to the subject of equipment. Various compact radiographic sources are described, ranging from miniaturized (weight approximately 4.5 kg) 100 kV X-ray tubes to a 10 curie, iridium 192 gamma ray source.

Source: R. A. Marshall of  
North American Rockwell Corp.  
under contract to  
Manned Spacecraft Center  
(MSC-15881, 15895)

*Circle 4 on Reader Service Card.*

## ULTRASONIC INSPECTION OF THIN-WALLED TUBING WELDS

A special ultrasonic search unit can reliably inspect the quality of melt-through welds on fusion-welded tubing couplers for hydraulic

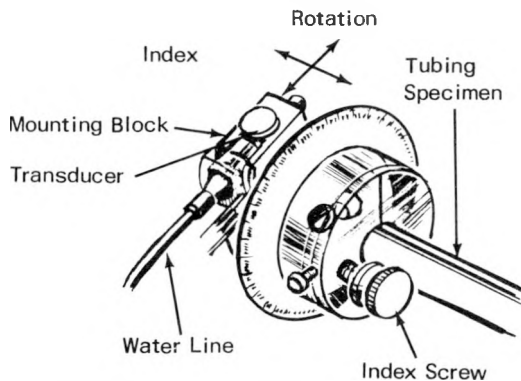

lines. The unit is used with high-resolution ultrasonic equipment to inspect welded tubing assemblies with diameters up to 2.5 cm and wall thicknesses from 0.06 to 0.25 cm. The unit, shown in the illustration, consists of a 25 MHz ultrasonic transducer, contained in a mounting block that is fitted with a water-line connector; a nonrotatable, "clamshell" plastic housing with an index screw and a pointer; and a rotatable search unit housing with circular protractor scale.

In the preparation for a tubing specimen inspection, the search unit housing is placed over the adapter side of the weld, and the non-

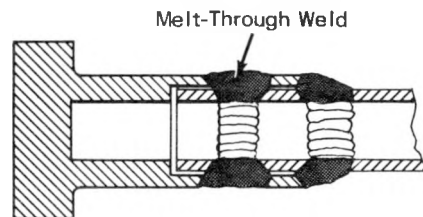

rotatable plastic housing is firmly mounted on the outer tube wall by two setscrews. The transducer and its mounting blocks are then arranged in the guide of the rotatable housing. The ultrasonic couplant, water, is fed into the mounting block beneath the face of the transducer. The signal trace is observed on the oscilloscope, and the mounting block is moved normal to the tubing axis to obtain optimum ultrasonic response. The mounting block is then secured by a setscrew.

To perform an inspection, the transducer assembly (in the rotatable housing) is rotated about the weld while ultrasonic response is observed on the oscilloscope. Weld-quality signal traces recorded on the oscilloscope indicate any

of the following weld conditions: no penetration, partial penetration, full penetration, and excessively rough outer surface. After the circumferential reading is completed, the index screw is rotated one-half turn to advance the transducer assembly 0.05 cm axially. The circumferential scanning procedure is repeated at this axial position and at successive 0.05 cm increments until the entire weld is covered. Weld quality is evaluated from the point-by-point oscillograms.

Source: G. J. Posakony  
Subcontractor to  
North American Rockwell Corp., and  
D. J. Hagemeyer of  
North American Rockwell Corp.  
under contract to  
Marshall Space Flight Center  
(MFS-18144)

*Circle 5 on Reader Service Card.*

### HIGH-PRECISION ULTRASONIC INSPECTION OF BRAZE JOINTS

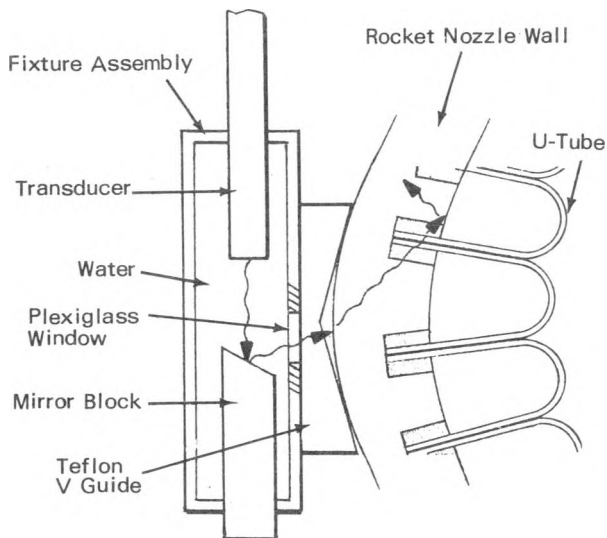

Good Bond: Signal Through Bonded Section Continues On

An ultrasonic "mirror" enables accurate aiming of a test beam without moving the entire beam-generating apparatus. In the high-precision nondestructive testing of special braze joints, where voids less than 1 mm in diameter within a braze depth of 2.5 mm must be detected, it was found that the sonic beam could not be aimed or focused with sufficient accuracy.

As shown in the figure, the test fixture consists of an ultrasonic transducer and a polished aluminum mirror block, mounted in a sealed chamber. The mirror can be rotated or moved longitudinally, enabling the beam to be aimed

to within very narrow tolerances. Water is pumped through the fixture to couple the 2.25 MHz ultrasound to the test object. A lithium sulfate, long-focus transducer is used, and

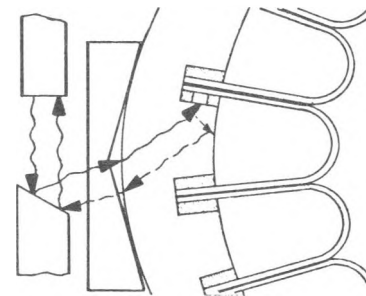

Bad Bond (On One Side of Joint):  
Signal Shear Wave at Unbonded Braze  
Echos Back to Transducer

internal design assures control of couplant path length within  $\pm 6$  mm.

In use, the fixture is held against the outside of the test object, and the signal is sent to a point on one side of a U-tube braze. If the braze is adequate, no echo occurs; if defective, a shear-wave echo returns.

Source: R. M. Peterson of  
Aerojet-General Corp.  
under contract to  
Space Nuclear Systems Office  
(NUC-10352)

*Circle 6 on Reader Service Card.*

### LOW-ENERGY GAMMA RAY INSPECTION OF BRAZED ALUMINUM JOINTS

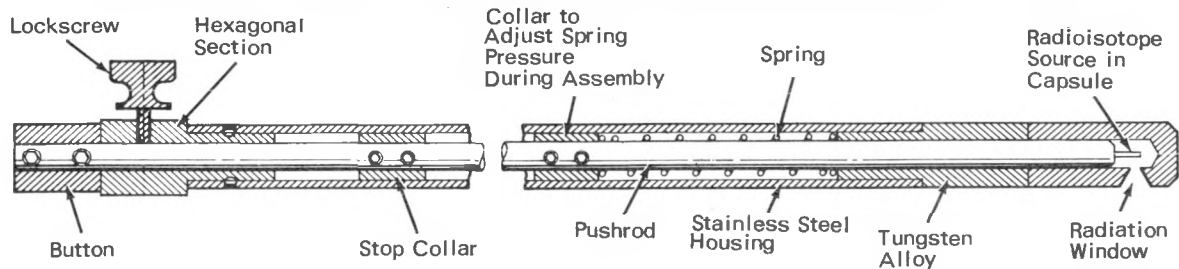

Americium 241 has been shown to be a suitable radioisotope (gamma ray source) for the radiographic inspection of brazed aluminum joints in areas of limited accessibility. The gamma ray intensity of the radioisotope was required to be sufficiently low to prevent film burnout at the imposed short source-to-film distances (only a few cm) through the low-density aluminum.

Americium 241, a transuranium nuclide with a half-life of approximately 465 years, is a gamma ray source with a principal photon energy of approximately  $10^{-14}$  J (0.060 MeV). The powdered isotope is contained in a capsule made of thin-walled stainless steel. The ends of the capsule are plugged with tungsten and then gold brazed.

As shown in the figure, the sealed capsule is mounted at the end of a spring-loaded pushrod

in the cylindrical probe assembly. A short hexagonal section at one end prevents the probe from rolling when it is set down; it also provides space for lock screws. In the "off" position, the capsule is held within the tungsten alloy radiation shield by spring compression. The capsule is exposed for radiography by pressing on the button fastened to the pushrod, and locking it in place with the lock screw. Positive stops for the "off" and "on" positions of the probe are provided by the stop collar and push-button.

Source: J. A. Brown of  
North American Rockwell Corp.  
under contract to  
Manned Spacecraft Center  
(MSC-01189)

Circle 7 on Reader Service Card.

### BRAZE JOINT QUALITY TESTED ELECTROMAGNETICALLY

An electromagnetic method can detect the extent of gold/nickel braze alloy flow in a braze joint. Ultrasonic scanning and radiographic techniques have proved troublesome due to system complexity and joint inaccessibility.

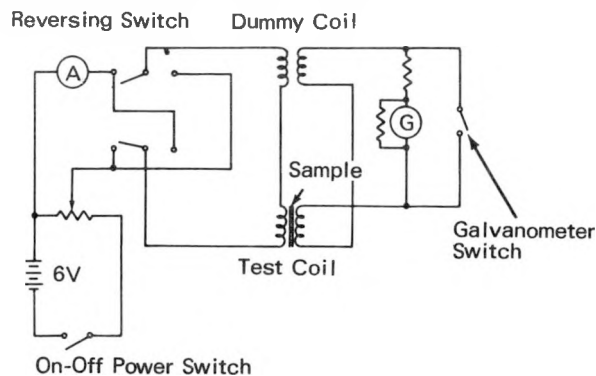

The method functions as follows: When a measured current through one side of a mutual inductor is reversed, an instantaneous but measurable voltage is induced in the other coil. When a magnetically permeable material is in the vicinity of the two coils, the secondary voltage is increased due to a more efficient coupling of the magnetic flux. The magnitude of the voltage increase is a function of the quantity, permeability, and geometry of the material inserted. In this case, the permeability and geometry of the material is held constant, and the effect of altering the quantity of material (braze alloy) is measured.

The sketch illustrates the test setup. Connecting the primary side of the test circuit to the common terminals of the switch reverses the

current in the test system without reversing the current through the ammeter. The test portion of the circuit is comprised of two identically wound mutual inductors and a microvolt detector circuit. The coil primaries are series connected with the power supply so that a current reversal produces twice the inductance of either coil (series aiding). The secondaries are series cross-connected so that equal inductance in both coils produces opposing voltages with a net of zero (series bucking). When a magnetic sample is inserted into one coil, the resulting voltages are still opposed but are of unequal magnitude, so that a net measurable voltage is

produced in the detector circuit. With this dummy coil method, readings can be obtained on all samples related to a zero reference. This method also results in greater magnification of differences between samples, because the mutual and self inductances of the coils are essentially negligible.

Source: R. D. McKown and D. B. Graves of  
North American Rockwell Corp.  
under contract to  
Marshall Space Flight Center  
(MFS-12795)

*Circle 8 on Reader Service Card.*

### EVALUATION OF BRAZE JOINT TESTING METHODS

A comparison of the three major nondestructive methods of testing brazed joints—X-ray radiography, neutron radiography, and ultrasonic testing—indicates that, because of the wide variety of base materials, brazing alloys, and brazing methods, no single method can supply all the desired inspection information.

The strength of a brazed joint depends upon such factors as defects inside the joint, the type of alloy formed between base metal and braze alloy, and the clearance of the brazed parts.

The most favorable clearance is 0.0254 mm for certain brazing alloys; less for others. This clearance setting is related to the alloy tensile strength. If the clearance is favorable for a particular alloy, the tensile strength can be several times higher than the brazing alloy strength itself under a three-dimensional force. Therefore, the comparison of nondestructive test effectiveness was made on samples having a 0.0254 mm clearance between the parts joined.

Brazing alloys containing thermal-neutron attenuating elements, such as boron, silver, and cadmium, were used for the evaluation. ASTM 304 stainless steel generally served as the base metal.

Artificial brazing faults were introduced by making holes of various specified diameters through brazing alloy foils, which were then sandwiched between the base metals. The radiographs of real brazed parts were compared with those of the artificial faults and also with photomicrographs of brazed samples.

The results of ultrasonic testing, either recorded on electrosensitive paper in two dimensions or pen recorded, were also compared with these radiographs and with photomicrographs. In general, the ultrasonic methods were found to be effective in the detection of nonbonds in diffusion bonded samples. However, defect resolution was a problem, particularly near edges of the samples. Radiography provided excellent resolutions of void- or inclusion defects, with the neutron radiographic technique showing particular advantage for brazing materials containing cadmium.

Source: A. Kanno  
Argonne National Laboratory  
(ARG-90175)

*Circle 9 on Reader Service Card.*

## Section 2. Leak Detection

### LEAK LOCATOR FOR VACUUM-JACKETED PIPELINES ELIMINATES NEED FOR REMOVING OUTER CASING

The illustrated leak locator, consisting of two Mylar disks, a source of nitrogen and helium gas, and a mass spectrometer, is capable of detecting leaks in a vacuum-jacketed liquid-hydrogen transfer line without removal of the entire outer jacket.

The leak locator consists of two Mylar disks cut to fit the inner diameter of the pipeline. A

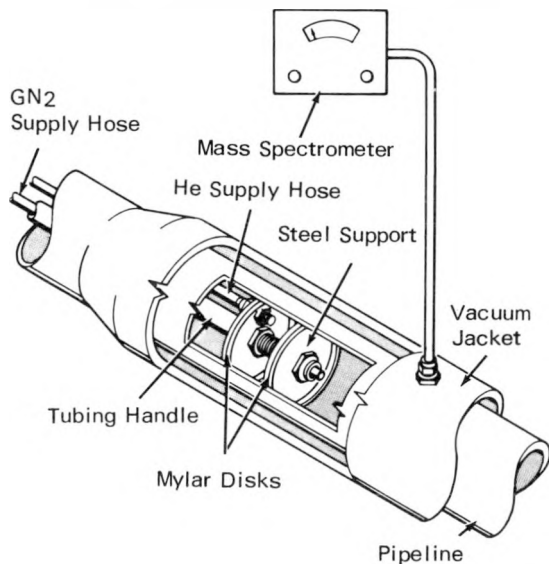

cavity is formed by the Mylar disks, which are spaced a small distance apart on a tubing handle and kept in place by two smaller steel supports. A mass spectrometer is used to monitor the area between the outer jacket and the pipeline. The pipe is first cut at a cone separator near the leak and the detector is inserted into that section of pipe. Low pressure gaseous nitrogen is fed through the tubing handle to fill the pipe in front of the detector. Helium is supplied to the cavity between the two Mylar disks and allowed to discharge back toward the opening. The leak locator is moved forward a distance equal to the spacing of the disks. With each move, the mass spectrometer is monitored. When the leaking section falls between the detector disks, the mass spectrometer will indicate helium. The jacket may then be cut at the proper place and the pipeline repaired.

Source: G. H. Wells of  
North American Rockwell Corp.  
under contract to  
Marshall Space Flight Center  
(MFS-00888)

*Circle 10 on Reader Service Card.*

### FLEXIBLE GAS LEAK DETECTOR PROBE

The illustrated leak detector probe can be hand-formed into any required shape, in order to reach otherwise inaccessible areas, without changing the cross section of either of the two tubes in the assembly. Made from two spiraled lengths of copper-braid-clad polyethylene tubing, the probe can be flexed without altering the

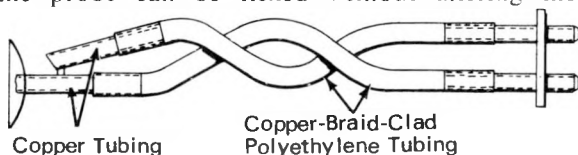

flow characteristics of one tube with respect to the other. The probe can also be restored to its original shape. Such properties are necessary for retaining the accuracy of the sensing device to which the probe is attached.

Source: G. E. Anderson of  
North American Rockwell Corp.  
under contract to  
Marshall Space Flight Center  
(MFS-91832)

*Circle 11 on Reader Service Card.*

## CHAMBER MONITORS GAS LEAKAGE THROUGH FLANGE SEAL

The figure shows a schematic diagram of a remotely monitored chamber that can accurately determine gas leakage rate through a flange seal. Under certain circumstances (e.g. flam-

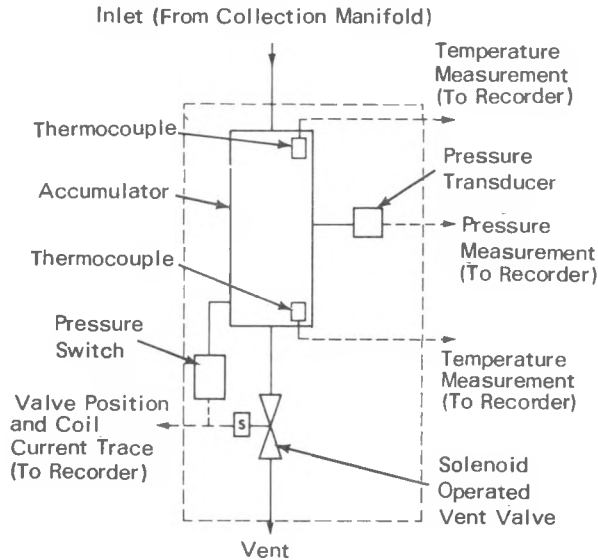

mable or explosive contents leaking through the seal), it is hazardous or impossible to measure leakage rates while in close proximity to the seal. In such cases, the flange may be enclosed, as shown, in a collection manifold; the data may then be collected electronically, transmitted, and interpreted from some remote point.

The solenoid vent valve, actuated by a pressure switch, prevents chamber pressure from exceeding a preset value and, once opened, will not reclose until the pressure has dropped to a lower value. With these two values known, a strip chart recording of the vent valve position, as a function of time, can be used to indicate gas leakage rate.

Source: S. K. Yoder of  
Aerojet General Corp.  
under contract to  
Space Nuclear Systems Office  
(NU-00064)

Circle 12 on Reader Service Card.

## LEAK DETECTION IN SEALED ELECTRICAL COMPONENTS

A new technique, involving the measurement of thermal conductivity, can detect leaks in hermetically sealed packages, leaks that are too small to permit easy detection by liquid immersion and too large for detection by such techniques as helium mass spectrometry. The technique involves placing the hermetically sealed package in a low pressure environment  $0.1$  to  $10^{-5}$  N/m<sup>2</sup> ( $10^{-3}$  to  $10^{-7}$  torr), heating an element within the sealed unit, and indirectly measuring the temperature rise of the element. Any leakage from the package will reduce the internal pressure and, simultaneously, the amount of convective heat transport. The associated increase in the temperature rise of the

heated element will reveal the presence of the leak. Many parameters, depending on the type of device within the sealed container, can be used to determine the temperature rise. Examples include the dc resistance of a wire-wound inductor or relay coil, the frequency of an oscillator crystal, and the leakage current across a semiconductor junction.

Source: R. J. Backe of  
Sperry Rand Corp.  
under contract to  
Goddard Space Flight Center  
(GSC-10892)

Circle 13 on Reader Service Card.

## FIXTURE FOR HELIUM-TRACER LEAK TESTING OF PIPE WELDS

The illustrated fixture, consisting of a split rubber torus fitted into a clamping ring with a vacuum hose fitting, is used in vacuum-testing

circumferential pipe welds, with a mass spectrometer to detect leaking helium gas.

The rubber torus is placed over the weld

and the clamping ring is tightened around the torus, producing a vacuum-tight seal. A vacuum line is then connected between the hose

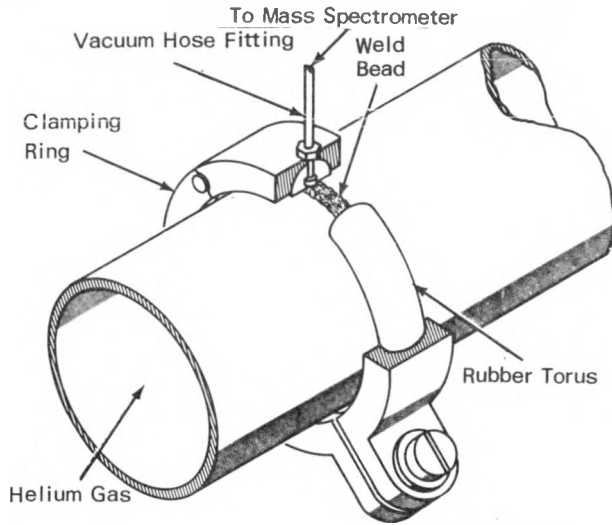

fitting and the mass spectrometer. Any helium that leaks through the weld accumulates in the annular space within the rubber torus and is conducted to the mass spectrometer.

The fixture enables quick, accurate helium-leak testing of welded pipe joints, since it can be connected (and disconnected) within several seconds. Only a few more seconds are required to establish equilibrium pressure within the rubber torus.

Source: R. G. Jones  
Marshall Space Flight Center, and  
J. A. Roney of  
Hayes International Corp.  
under contract to  
Marshall Space Flight Center  
(MFS-02167)

*Circle 14 on Reader Service Card.*

#### HELIUM LEAK TEST ENVELOPES FOR TUBE FITTINGS

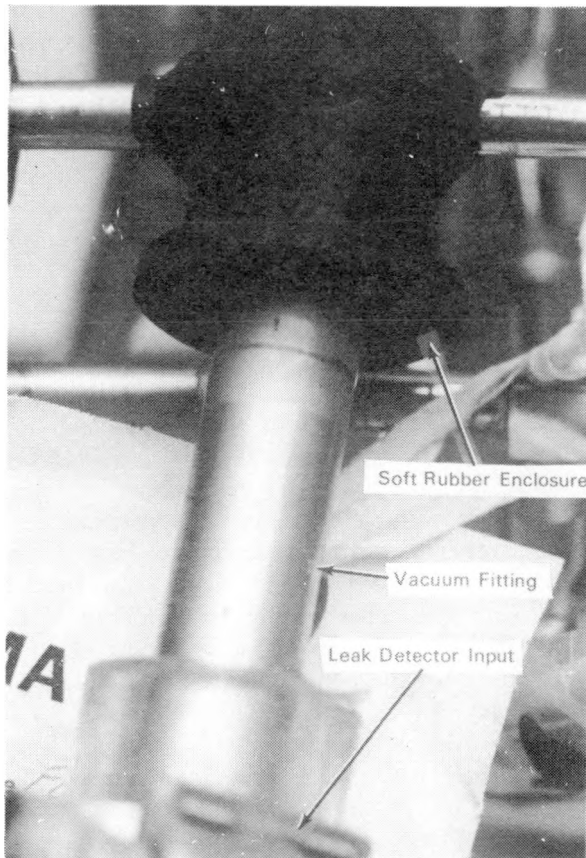

The use of another accessory intended to aid in helium leak testing is shown in the photograph. After standard "sniffer" leak detection procedures have indicated a leaking fitting, the accessory, a specially moulded, split, soft rubber enclosure, is slipped over the fitting. A vacuum fitting on the enclosure is then connected directly to the leak detector input. Use of the enclosure ensures collection of all escaping helium, and hence greatly increases the accuracy of leak-rate determination.

Source: L. L. Stennett of  
North American Rockwell Corp.  
under contract to  
Manned Spacecraft Center  
(MSC-15410)

*Circle 15 on Reader Service Card.*

**GAS LEAKAGE RATE DETERMINED FROM BUBBLE FORMATIONS**

Gas leaks from fittings joined to pipelines are commonly detected with various liquid leak-detection agents applied to the joints. Evidence of leaks is provided by the appearance of bubbles at the joints, but estimation of the leakage rate has been entirely subjective.

A series of measurements, using a commercial leak-detection agent on both threaded and flanged fittings, has yielded standards of bubble

appearance that allow quantitative estimation of leakage rate. Standards have been proposed for three classes of bubble formation on both threaded and flanged joints.

Source: J. E. Decastra and F. E. Wells  
Marshall Space Flight Center  
(MFS-14841)

*Circle 16 on Reader Service Card.*

**BURST-DIAPHRAGM LEAK DETECTOR**

An inexpensive, rapid method for simultaneously leak checking all flange seals in a complex assembly under actual operating conditions involves replacing the time consuming flowmeter system with a simple, easily constructed, burst-diaphragm leak-detector assembly mounted on each of the drain ports.

Each assembly consists of a standard plumbing reducer, two stainless-steel, ball-seat washers, and a B-nut or bushing. A metal diaphragm (nickel, silver, gold, or aluminum) is inserted between the ball-seat washers. The assembly is

then torqued to a predetermined value and tested for leaks. Any number of detectors can then be installed into flange seal leakage ports. During actual system operation, any leakage due to a defective seal or flange creates a pressure build-up, ultimately causing rupture of the diaphragm.

Source: J. A. Pascolla of  
North American Rockwell Corp.  
under contract to  
Marshall Space Flight Center  
(MFS-14500)

*Circle 17 on Reader Service Card*

**STUDY OF LEAK TRACER-GAS DIFFUSION**

In the location of leaks in a pneumatic system by injecting a small quantity of a tracer gas (usually either Freon-22 (CHClF<sub>2</sub>) or helium) and then detecting any escaping tracer, special precautions are necessary to ensure adequate diffusion of the tracer gas throughout the system to be tested. This conclusion was reached in a recent study of tracer-gas diffusion.

A concentration of 1 volume percent in air was used for the Freon experiments. This concentration is often used in leak detection. Two common methods of introducing Freon were tested: slug injection and premixing with air in a special Freon injector. The tests were made with a nonspecific system consisting of spherical containers and interconnecting tubing. Sampling ports were located at five points, and samples were analyzed with a mass spectrometer to

measure the Freon concentration at each location. The various slug injection modes tested did not produce the desired uniform mixture of Freon and air. Much of the system contained little or no Freon, while other portions had considerably more than the desired concentration. However, suitable diffusion was obtained with the Freon injector. Lower concentrations that did occur at the dead end of the system can be prevented by proper venting during fill.

A concentration of 10 volume percent in air was used for the helium tracer experiments. The common slug-injection technique was used, both with the nonspecific system described above and with a 350 m<sup>3</sup> tank with sampling ports at six locations. A helium mass spectrometer was used to measure the concentration of helium sampled from each port. The various

slug-injection modes for the nonspecific system did not produce the desired uniform mixture of helium and air. The slug injection modes tested in the large tank produced varying results. However, after a period of four hours, the helium had generally diffused uniformly throughout the entire tank volume.

The test results for both Freon and helium show that uniform mixing of the tracer gas does not always occur; some portions of the system

are likely to be completely devoid of tracer. It is therefore mandatory that the method of tracer-gas injection be established to ensure uniform distribution, and that the system under test be evaluated to determine optimum fill locations and required vent points.

Source: J. L. Brown  
Marshall Space Flight Center  
(MFS-20254)

*Circle 18 on Reader Service Card.*

### TIME-EXPOSURE PHOTOGRAPHY PINPOINTS LEAKAGE SITES

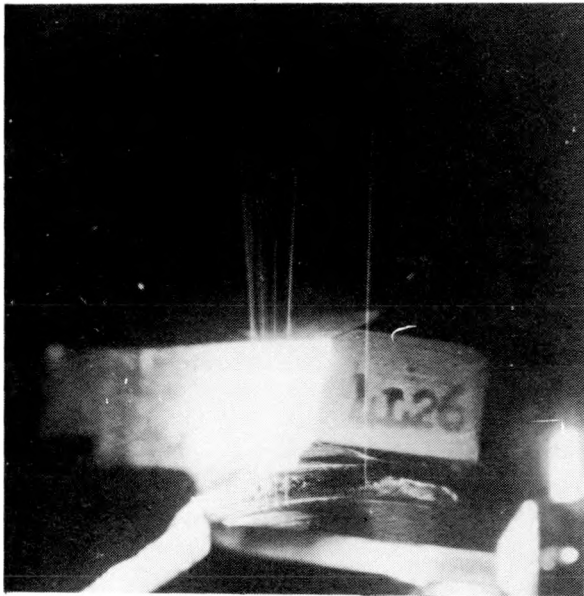

The photograph indicates the type of results obtainable with a modified fluid-immersion leak test. With the substitution of time-exposure photography for direct observation of a suspected leak, a solid trail is revealed, and the trail terminates abruptly at the source of the leak. The trail, in lieu of the chain of individual bubbles seen by direct observation, makes it very easy to pinpoint exact leakage sites, particularly when, as in the photo, several sites lie close together.

Source: R. W. Savage and J. R. Ranstrom of  
North American Rockwell Corp.  
under contract to  
Manned Spacecraft Center  
(MSC-15957)

*Circle 19 on Reader Service Card.*

### DISPENSER LEAK-TESTS AND STERILIZES RUBBER GLOVES: A CONCEPT

The illustrated portable apparatus will leak-test and sterilize a pair of rubber gloves, then permit the gloves to be fitted without external handling. As shown, two open sterilizer cups are fitted to a vacuum line and provided with multiple-nozzle spray heads that can cover the entire volume of the cups. The nozzles are connected to a reservoir of sterilizing agent. The opening of each cup is flared to hold the stretched cuff of a rubber glove.

The gloves to be sterilized are inserted into the sterilizer cups and held in place by stretch-

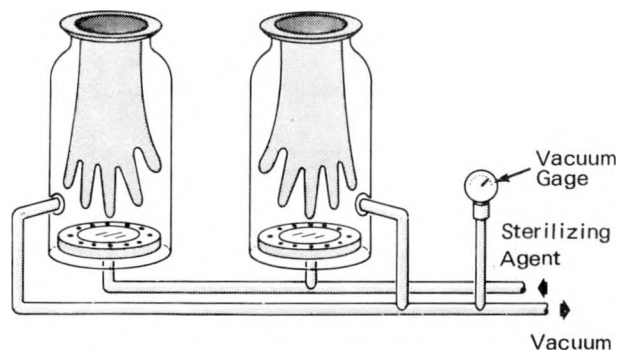

ing the cuffs over the rims. The vacuum system is then turned on to inflate the gloves in the sterilizer cups for leakage testing. If the vacuum gage indicates that the gloves are not porous, the vacuum pump is turned off (without removing the vacuum from the cups) and the sterilizer solution is sprayed over the external surfaces of the gloves. When washing is completed, the sterilizing spray is turned off and the hands are

inserted into the gloves, applying a slight downward pressure to release the cuffs from the rims of the cups.

Source: North American Rockwell Corp.  
 under contract to  
 Manned Spacecraft Center  
 (MSC-00285)

Circle 20 on Reader Service Card.

### DETECTING HOLES IN THIN POLYMERIC FILMS

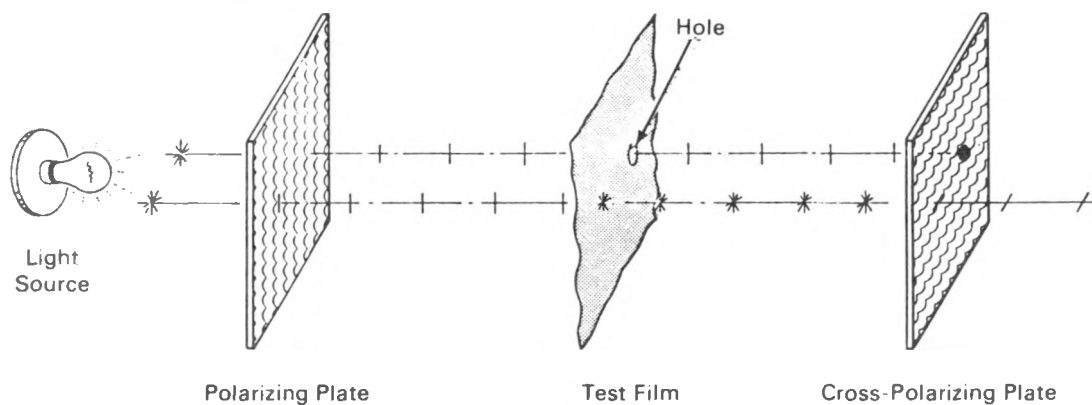

The increasing use of thin polymeric films for containing liquids and gases has necessitated the development of an optical inspection method for detecting and locating small holes and tears in the films. Polarized light is employed because thin films of common polymers (polyesters, polyimides, polyethylenes, fluorocarbons, etc.) are highly transparent to visible light. Such transparency makes the detection of a hole very difficult and time-consuming under standard lighting conditions. There is no contrast between the light which has passed through the film and that which has passed through the hole. Polarized light can provide the required visual contrast.

As shown in the figure, the section of film being inspected is back-lighted with light from a polarizing plate and viewed through a second polarizing plate, oriented perpendicular to the first. The dispersion, refraction, and stress-optic rotation of the polarized light as it passes through the film renders intact film areas visible when viewed through the cross-polarized plate. The polarized light which passes through

a hole in the film appears as a black area when viewed through the cross-polarized plate. (Polarized sunglasses are an effective substitute for the second polarizing plate when large film areas are to be inspected.)

The major optical effects which render different films visible vary with the base polymers and molecular orientations of the films. Stretch-oriented films such as polyester and polyimide show a high degree of birefringence effects and appear in rainbow hues, particularly when the films are wrinkled. Thermoplastic films such as polyethylene, polypropylene, and FEP fluorocarbon are visible as a uniform gray color. Holes always show as black areas in the colored background of the film.

Source: K.E. Wiedekamp  
 and A.D. Von Volkli of  
 The Boeing Co.  
 under contract to  
 Lewis Research Center  
 (LEW-10876)

No further documentation is available.

## WICK GIVES CONVENIENT LEAK MONITOR IN FOAM-INSULATED REGION

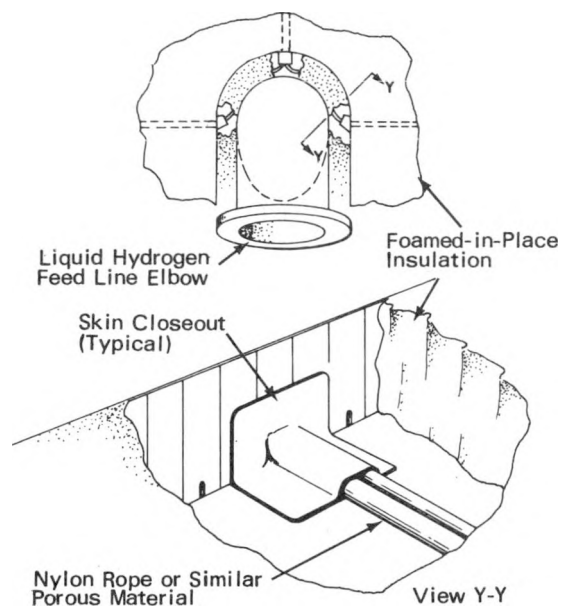

The figure illustrates a convenient technique for draining off gas leakage from foam-insulated piping, and at the same time providing a convenient leak detection test point. The technique involves installing a wick, made of nylon rope or a rolled-up length of loosely-woven nylon fabric, between the piping and the insulation surface. The installation is very easily performed before the foam is emplaced, using only the wicking and a length of pressure-sensitive tape.

Source: W. Merrihugh of North American Rockwell Corp. under contract to Marshall Space Flight Center (MFS-02598)

Circle 21 on Reader Service Card.

## DETERMINATION OF HYDROGEN LEAKAGE THROUGH LAMINATED HONEYCOMB MATERIAL

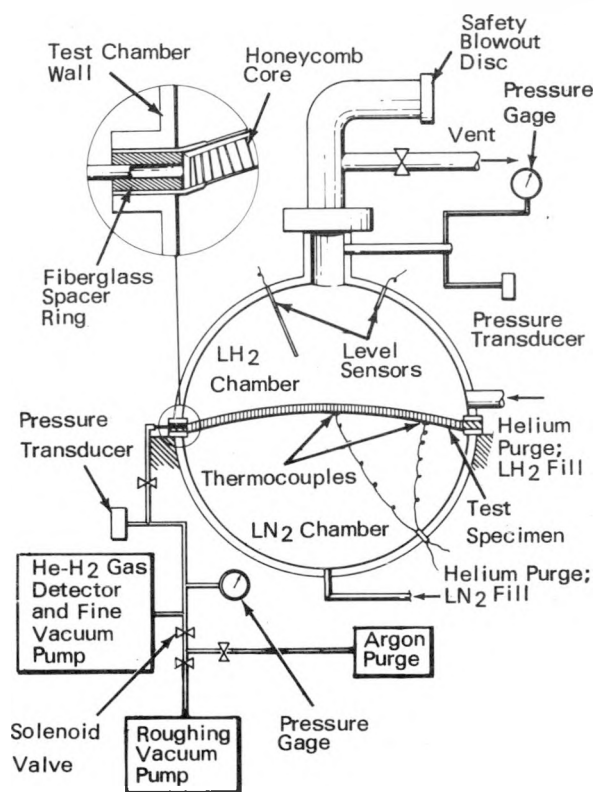

To determine the leakage rate of liquid hydrogen through bonded splices in honeycomb/fiberglass laminated bulkheads, the hydrogen gas can be removed from the honeycomb cores by machining narrow slots in the fiberglass core immediately beneath the splice centerline. The slots extend radially from the bulkhead's center to its perimeter and adjoin passages bored through a fiberglass spacer ring.

The figure is a cross-sectional view of a test specimen mounted in a spherical cryogenic test vessel. The passages through the spacer are connected to a manifold, which in turn is connected to a vacuum source and a leakage measuring system. During actual use, the illustrated system successfully detected hydrogen leakage rates as low as  $10^{-7}$  cc/sec.

Source: J. C. Freese of McDonnell Douglas Corp. under contract to Marshall Space Flight Center (MFS-12171)

Circle 22 on Reader Service Card.

## Section 3. Adhesive Bonding and Composite Materials Inspection

### INFRARED INSPECTION OF VENTED CORK-ON-FOAM INSULATION

An infrared thermographic technique for inspecting vented cork-on-foam insulation involves the introduction of cold gas into the grooved venting in the foam. The cold gas causes any existing cracks to widen, thus making them easier to detect, and also provides the source for a thermal gradient which can be observed thermographically.

This simple, inexpensive, and easily automated technique could be applied in testing

many commercial products such as factory-assembled housing modules, electronic panels, and kitchen appliances.

Source: F. H. Stuckenberg of North American Rockwell Corp. under contract to Manned Spacecraft Center (MSC-17269)

*No further documentation is available.*

---

### TOOL FOR VACUUM INSPECTION OF BONDED CORK INSULATION

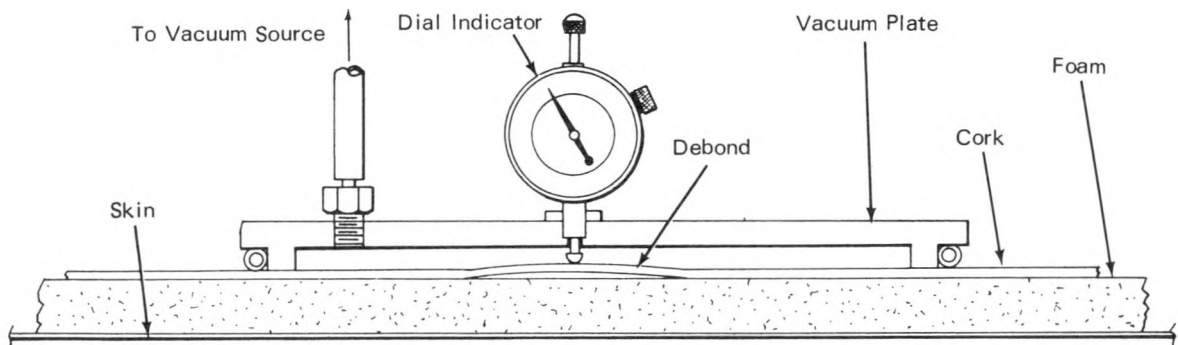

The vacuum-operated tool shown in the figure can easily detect unbonded regions in bonded cork or cork-on-foam insulation. The tool consists of a square plate of transparent plastic, with a square spacer and a rubber seal mounted on the plate perimeter. A quick-release vacuum fitting and a spring-loaded displacement gage with a dial indicator are installed through the square plate.

The plate is placed over an area of bonded

cork insulation, and a preset vacuum is applied. The amount of deflection on the gage indicates whether or not the surface is properly bonded.

Source: H. L. Pontious, H. S. Massey, and W. M. Zinsley of North American Rockwell Corp. under contract to Marshall Space Flight Center (MFS-24011)

*No further documentation is available.*

### ACOUSTIC INSPECTION OF CORK-ON-FOAM BONDED INSULATION

The illustrated inspection tool senses the resonant vibrational response from cork-on-foam insulation that is subjected to low-intensity shock pulses. The tool enables interpretation of the response amplitudes to reveal the presence of unbonded regions between cork and foam.

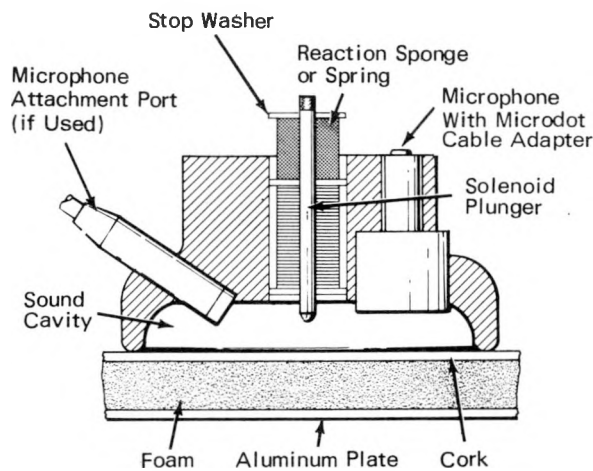

As shown, the shock exciter is a centrally mounted solenoid tapper; a microphone detects the vibrational response of the surface. The tapper impacts the surface at a predetermined rate, in the center of a cylindrical chamber that forms a Helmholtz resonator and enhances vibrations in the 300-1900 Hz range.

The microphone output is coupled through a linear amplifier to a 300-2000 Hz bandpass filter. The filtered output is amplified, rectified, and applied to the gate of a Schmitt trigger. When the dc level received at the gate exceeds a preset minimum, the trigger actuates a driver amplifier, which lights a debond-indicator lamp.

Source: M.J. Suppanz, C.E. Davis, J.D. Fageol, and F. Molinaro of North American Rockwell Corp. under contract to Marshall Space Flight Center (MFS-16936)

Circle 23 on Reader Service Card

### BALLPOINT PROBE FOR ULTRASONICALLY TESTING COMPOSITE STRUCTURE BOND INTEGRITY: A CONCEPT

The conceptual ballpoint-type ultrasonic probe assembly shown in the figure could scan in any direction, eliminate external couplant spray, and focus precisely on a bond line. The probe would combine the features of larger,

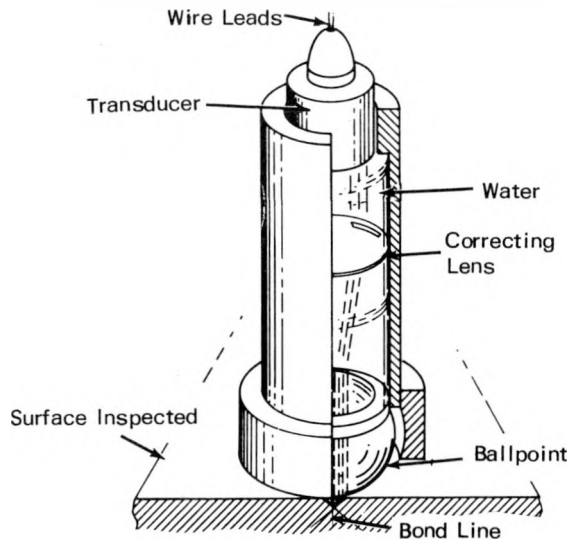

more complex probes into one small, easy-to-use unit.

The probe consists of a transducer with water as a couplant, a correcting lens, and a ballpoint contact.

During ultrasonic tests, the ballpoint is carefully placed on the bond line. The ultrasonic beam is then focused by varying the distance between the correcting lens and the transducer face (varying the focal point).

An external couplant spray is not required. The ball applies its own self-contained couplant, which flows around the edges of the ball. Scanning can be performed in any direction because of the rotatable ball.

Source: R.E. Melton of Spaco, Inc. under contract to Marshall Space Flight Center (MFS-13590)

Circle 24 on Reader Service Card

## ULTRASONIC EMISSION TESTING OF ADHESIVE BONDS

Preliminary tests on a number of adhesive bonds subjected to tensile stresses indicate that detection of the acoustic energy emitted by the bonds at frequencies above 16 kHz can be used

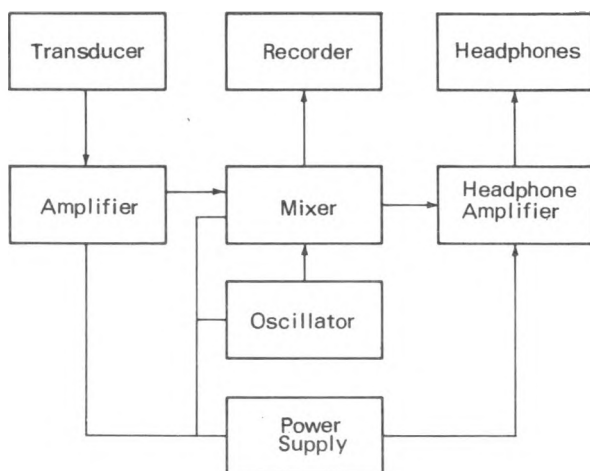

to determine bond strength. The tests are performed in the following manner: An adhesive to be tested is used to form a bond between two small aluminum blocks. A piezoelectric transducer is then secured to one of the blocks and the specimen is mounted in a tensile tester. The transducer, which detects the acoustic energy generated by the adhesive bond as it is

subjected to increasing tensile stress, is a disk of barium titanate-lead zirconate that has a frequency response up to 100 kHz or more.

The output of the transducer is amplified with a gain of 5000 at a center frequency of 31 kHz and a bandwidth of 5 kHz. The amplifier output is fed to a mixer, along with a signal from a 32 kHz oscillator. The difference frequency from the mixer is selected, and the output of the transducer is translated to a range of 0.1 to 4 kHz. This signal is detected and used to drive a recorder to plot average frequency as a function of applied stress (separately monitored). A set of headphones may also be connected to the mixer to enable an operator to listen to the acoustic signals generated by the system. These signals can easily be distinguished from the noise generated by the test stand or environment. The stressed adhesive bond produces high-pitched crackling sound pulses of very short duration.

Source: G. Schmitz and L. Frank of  
General American Transportation Corp.  
under contract to  
Marshall Space Flight Center  
(MFS-00799)

*Circle 25 on Reader Service Card*

ACOUSTIC DETERMINATION OF ADHESIVE BOND STRENGTH  
IN HONEYCOMB COMPOSITES

A novel method for nondestructively determining the bond strength of adhesive-bonded honeycomb composites is based on the fact that strength is a function of the vibration-damping properties of the bond. The circuit represented by the block diagram can be used to: (1) determine the fundamental and harmonic vibration responses and modes of honeycomb composites, both at ambient temperature and as a function of temperature; (2) correlate these responses with varying cohesive bond strength; (3) determine the effect of face-sheet thickness variations; (4) optimize the characteristics of the excitation transducer and evaluate self-

heating capabilities; and (5) design a system for measuring bond strength.

A study has led to the development of the Displacement-Oriented Transducer (DOT) System for measuring bond strength. The system (see fig.) is basically a vibration-analysis method which produces high-level, variable-frequency excitation forces in a metallic structure, detects microinch displacements produced in the structure, and provides output signals for recording.

The excitation circuit comprises an automatic swept-frequency source and power amplifier driving an electromagnetic transducer. Excitation levels reach up to 15 A at 30 V over the fre-

quency range from 0.01 to 10 kHz. An operational amplifier compares the input signal with a feedback signal that is proportional to the transducer current. This corrects coil-impedance changes and ensures constant-current drive over the range of operation.

The system for detecting vibration response uses a commercial, fiber-optic displacement instrument sensitive to displacements of  $1.27 \times 10^{-5}$  m (5  $\mu$  in.) over frequencies ranging from dc to 40 kHz. The fiber-optic probe is accurately positioned coaxially in the excitation transducer. The displacement instrument is modified to provide an amplified and demodulated ac output proportional to the measured

dynamic displacement amplitude. The displacement signals may be monitored on a cathode-ray spectrum analyzer or plotted on an x-y recorder as a function of the excitation frequency response of the structure.

Operation of the DOT System is based on an initial calibration from response measurements of composite materials whose strength properties are known. From these data, the system can be calibrated in terms of bond-strength deviation from a calibration standard, using resonance-response amplitude, frequency, or half-bandwidth. The displacement-oriented transducer can be operated either without direct contact or supported on the composite with variously sized rings or with three-point contacts. The material under test is swept-frequency driven at selected levels of excitation until a resonance response is indicated. Particular frequency resonances related to the geometry effects of the test system are ascertained, and only the resonances associated with the damping of the composite are measured.

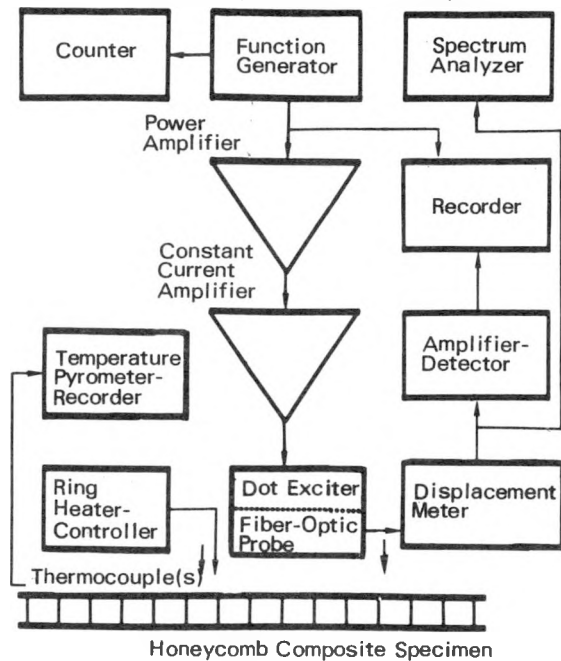

Documentation is available from:

National Technical Information Service  
Springfield, Virginia 22151  
Price \$3.00  
Reference: TSP69-10464

Source: D.E. Thompson of  
North American Rockwell Corp.  
under contract to  
Marshall Space Flight Center  
(MFS-20397)

## IMPROVED ULTRASONIC COUPLANT FOR INSPECTING POROUS MATERIALS

A recently formulated ultrasonic couplant has improved properties that permit contact inspection of porous materials without causing surface contamination. Previously available couplants were unsuitable for use on porous materials. Water based couplants tended to dry too rapidly, and did not have sufficient wetting capability for good wave propagation between the transducer and the material being

inspected. Other couplants could not be used because they would contaminate the porous material. The improved couplant is noncontaminating, noncorrosive, and nontoxic. It includes a fluorescent dye, which allows for verification of surface cleanliness after clean-up. The noncontaminating properties of the couplant, combined with adequate wave propagation capability, make this a novel product, superior

to any commercially available couplant for the inspection of porous materials such as styro-foam or concrete.

The composition of the couplant is as follows:

Hydroxyethyl cellulose	48.0 grams
Sodium benzoate	3.0 grams
Fluorescein	0.1 grams
Sodium dichromate	2.0 grams
Tap water	3.0 liters

Source: C.C. Kammerer of  
North American Rockwell Corp.  
under contract to  
Marshall Space Flight Center  
(MFS-16432)

*No further documentation is available.*

### LIQUID CRYSTALS DETECT VOIDS IN FIBERGLASS LAMINATES

A thin coating of liquid crystal solution applied to a fiberglass-laminate test article will, when heated, indicate the exact location of defects by differences in color. The surface to be tested is first painted with a dull black, water soluble, solvent-resistant paint. Over this a thin coating of liquid crystal solution is applied. After the solvent evaporates, the test panel is heated.

As heating takes place, the solution rapidly covers the color spectrum, changing first to red, then to yellow, green, blue, violet, and, as heating continues, back to colorless. On cooling,

the color sequence occurs in reverse order. Differences in heat transmission caused by defects within the material produce differences in surface temperature, causing differences in liquid crystal color. Color photographs may be taken for permanent records.

Source: W.T. Hollar of  
General Dynamics/Convair Division  
under contract to  
Lewis Research Center  
(LEW-10104)

*Circle 26 on Reader Service Card*

### POLARIZED LIGHT REVEALS STRESS IN MACHINED, LAMINATED PLASTICS

Exposing predrilled printed circuit boards to polarized light can reveal locked-in stresses that would cause later rejection of the board.

Improper drilling (drill speed, feed speed, or drill sharpness) can cause locked-in stresses in laminated plastic components such as terminal and printed circuit boards. These stresses cannot be detected under normal light until after exposure to the elevated temperatures of soldering

operations, at which time they become clearly visible as fractures and delaminations.

Source: J. Frankowski of  
General Dynamics/Convair Division  
under contract to  
Lewis Research Center  
(LEW-10018)

*Circle 27 on Reader Service Card*

### TESTING THE DEGREE OF CURING IN EPOXY-IMPREGNATED SHEETS

A rapid visual test and a simple quantitative test have been devised to give indications of the degree of cure of particular epoxy resin binders in prepreg stock (sheets of fabric impregnated with a resin in a partially cured condition, known as the B stage). Stacked layers of

prepreg stock are normally formed into laminates (such as for printed circuit boards) under controlled pressure, temperature, and time to ensure proper bonding between the individual prepreg sheets. If the prepreg material is overcured, it will not bond properly.

In the visual test, samples of the prepreg material are immersed in an aqueous morpholine solution at room temperature for 5 minutes. The samples are then rinsed in clear water and inspected visually.

Normal prepreg samples (representing particular epoxy compositions) exhibit a milky white appearance; highly overcured prepreg material remains almost clear. A definite gradation of cloudiness corresponding to the degree of overcure can be observed between these two extremes.

In the quantitative test, small weighed samples of the prepreg material (representing

specific epoxy compositions) are extracted with reagent grade acetone at room temperature, air dried at the same temperature, and reweighed. The weight loss, calculated on a resin content basis, decreases in a consistent and repeatable manner as the degree of cure increases.

Source: M. Ladaki and W.G. Nigh of  
North American Rockwell Corp.  
under contract to  
Marshall Space Flight Center  
(MFS-13131 and 13132)

*Circle 28 on Reader Service Card*

### INSPECTION OF OPEN-FACE HONEYCOMB SEALS USING LOW-VISCOSITY LIQUIDS

The following four techniques have been investigated for use in inspecting an open-face honeycomb turbine seal: (1) water-base dye penetrant, (2) Freon TF, using visible light; (3) Freon TF with fluorescent additive, using ultraviolet light; and (4) ultrasonic C-scan facsimile recording. The following results were noted: (1) Defective brazed cells that leak can be located using any of the above mentioned low-viscosity liquids; (2) the fluorescent additive improves the ability to distinguish acceptable cells from poorly brazed, defective cells; and (3) the low-viscosity liquid procedures are equal to the ultrasonic technique in locating defective cells.

The liquid inspections using Freon were performed by slowly immersing the part in the liquid and allowing it to dwell until all air bubbles were out of the cells. The part was then removed from the solution and tilted slightly. After draining for about 30 seconds, the cells were examined. In good quality cells, a meniscus formed across the top of the cell. In leaking

cells, the fluid level was lower, forming a shadow area within the cells.

The dye penetrant inspection was performed by applying liquid along the edges of the part and allowing it to penetrate into defective cells by capillary action. Defective cells were made clearly visible by this technique.

Ultrasonic testing was performed by immersing the part in water and scanning it with a short-focus 15 MHz transducer, using available equipment. Only one cell could be scanned at a time. Although the reliability of detection was as good as that obtained with the low-viscosity liquids, the cost was prohibitive. However, ultrasonic scanning may be necessary if a permanent record is desired.

Source: J.A. Meyer of  
North American Rockwell Corp.  
under contract to  
Marshall Space Flight Center  
(MFS-18976)

*Circle 29 on Reader Service Card*

### AUTOMATIC ULTRASONIC QUALITY INSPECTION OF BONDED HONEYCOMB ASSEMBLIES

An automated ultrasonic inspection system consists of inner and outer transducer-positioning assemblies with suitable motor controls a centerless turntable assembly to rotate the test

parts, water squirter assemblies to ensure the water-tightness of joined areas, and an inspection program, completely encoded on tape and suitable for use on a high speed computer. The

system can inspect bonded honeycomb assemblies quickly and accurately.

The assemblies to be inspected ranged up to 10 m in diameter, and consisted of cylindrical, truncated, hemispherical, and flat sections of varying lengths, with asymmetrical internal and external protrusions. The inspection record had to indicate clear, interpretable, and precisely situated test results, including the size and extent of all nonbonds.

Each assembly required careful preparation prior to its inspection, to ensure that water from the squirter assemblies could not enter through joined areas. The prepared assembly was then placed on the turntable with the applicable tooling. The position and relative clearance of the assembly surface, and the instrumentation, recording model, and all program controls, were readed for an automatic inspection as required by the specific test. All suspect areas were further evaluated by complementary ultrasonic techniques (e.g., contact, resonance, or frequency-shift.)

Eight-channel tape readers were utilized as the program control. Since the position and gimbals motions of both the inside and outside transducer assemblies required independent programs, six channels were designated for their

control. One channel was used to control the transducer positioning logic during an automatic inspection cycle, and the remaining channel controlled the turntable angular velocity to maintain uniform surface inspection speed and recorder writing density.

The program information was generated with the aid of a high speed computer, coded with the necessary mold-line equations for both the inner and outer surfaces of each specific panel assembly. A complete series of calculations was performed, and the data was stored on magnetic tape.

The programmed tape was indexed past the tape reader photocell head to initiate the operation of each controlled function. Since the tape reader was only required to initiate automatic programmed transducer indexing once per turntable revolution, a control was provided to permit the transducer-index increment to be adjusted by the operator.

Source: C.C. Kammerer of  
North American Rockwell Corp.  
under contract to  
Manned Spacecraft Center  
(MSC-00859)

*Circle 30 on Reader Service Card*