



**AN ULTRASONIC SYSTEM  
FOR TESTING ISOTOPE HEAT CAPSULES**

B. E. DOZER

MARCH, 1968



AEC RESEARCH &  
DEVELOPMENT REPORT

SENT TO	DATE	BY	RECEIVED DATE
<del>CE King</del>	<del>3-28-68</del>	<del>3701E</del>	<del>APR 9 1968</del>
PROD. REACT DIV	6-30-68	2nd	AUG 23 1968
for KA WRIGHT			
JL Rhoads	AEC	US3949 P80615	NOV 4 1968

63003

## LEGAL NOTICE

This report was prepared as an account of Government sponsored work. Neither the United States, nor the Commission, nor any person acting on behalf of the Commission:

A. Makes any warranty or representation, expressed or implied, with respect to the accuracy, completeness, or usefulness of the information contained in this report, or that the use of any information, apparatus, method, or process disclosed in this report may not infringe privately owned rights; or

B. Assumes any liabilities with respect to the use of, or for damages resulting from the use of any information, apparatus, method, or process disclosed in this report.

As used in the above, "person acting on behalf of the Commission" includes any employee or contractor of the Commission, or employee of such contractor, to the extent that such employee or contractor of the Commission, or employee of such contractor prepares, disseminates, or provides access to, any information pursuant to his employment or contract with the Commission, or his employment with such contractor.

### PACIFIC NORTHWEST LABORATORY

RICHLAND, WASHINGTON

operated by

BATTELLE MEMORIAL INSTITUTE

for the

UNITED STATES ATOMIC ENERGY COMMISSION UNDER CONTRACT AT(45-1)-1830

PRINTED BY/FOR THE U. S. ATOMIC ENERGY COMMISSION

3 3679 00060 7525

BNWL-649  
UC-23, Isotope-Industrial  
Technology

AN ULTRASONIC SYSTEM  
FOR TESTING ISOTOPE HEAT CAPSULES

By

B. E. Dozer

Nondestructive Testing Section  
Applied Physics and Electronics Department

March 1968

FIRST COPY  
DISC 100

PACIFIC NORTHWEST LABORATORY  
RICHLAND, WASHINGTON

Printed in the United States of America  
Available from  
Clearinghouse for Federal Scientific and Technical Information  
National Bureau of Standards, U.S. Department of Commerce  
Springfield, Virginia 22151  
Price: Printed Copy \$3.00; Microfiche \$0.65

TABLE OF CONTENTS

LIST OF FIGURES . . . . .	iv
INTRODUCTION . . . . .	1
SUMMARY . . . . .	1
PRINCIPLE OF OPERATION . . . . .	2
TESTER DESCRIPTION . . . . .	2
Pulse Generator. . . . .	2
Signal Processing . . . . .	2
Pulse Logic System. . . . .	10
Transducer Position Indicators. . . . .	12
X-Y Recording System . . . . .	14
Time Measurement System . . . . .	14
Power Supply. . . . .	15
Motor Control Panel . . . . .	15
The Lathe. . . . .	16
TESTER OPERATION PROCEDURES . . . . .	16
Porosity and Weld Penetration . . . . .	17
Longitudinal Cracks . . . . .	21
Wall Thickness . . . . .	21
DISTRIBUTION . . . . .	27

LIST OF FIGURES

1	Isotope Heat Source Tester	3
2	Isotope Heat Source Tester - Transducer Bridge	4
3	Isotope Heat Source Tester - Electronic Console	5
4	Circuit Diagram	7
5	Oscilloscope Waveforms	8
6	Oscilloscope Waveforms	9
7	Logic Diagram	11
8	Oscilloscope Waveforms	13
9	Test Arrangement, Crack and Weld Test	18
10	Simulated Snap 21 Fuel, Capsule 8, End 11, Weld Test	19
11	Simulated Snap 21 Fuel Capsule	20
12	Modified Arrangement, Weld Test	22
13	Simulated Snap 21 Fuel, Capsule 5, End 10, Weld Test	23
14	Crack Test, 2 inch Diameter x 1/4 inch Wall SST Tubing	24
15	Test Arrangement, Wall Thickness Measurement	25
16	Wall Thickness Test, 2 inch Diameter Eccentric, SST Tube	26

## AN ULTRASONIC ISOTOPE HEAT SOURCE TESTER

B. E. Dozer

INTRODUCTION

This report describes a program to develop a nondestructive (ultrasonic) tester and testing procedure to perform integrity tests on isotope heat source containers. The increased application of isotope heat sources has brought more attention to the engineering problems encountered during fabrication. One of the most important of these problems is insuring the isotope containment during the long unattended periods of use. To determine the integrity of the heat source container, a nondestructive testing procedure must be adopted to test each heat source after fabrication.

SUMMARY

An ultrasonic tester was developed to test cylindrical isotope heat sources for wall weld penetration and cracks, wall defects, and to measure the wall thickness. The tester consists of an electronic console and a mechanical device to rotate the sample. The electronic console is made up of electronic

pulse processing equipment, a transducer location system, an X-Y recorder, a pulse time measurement system, motor controllers, and miscellaneous electronic equipment. The mechanical rotating device is a 14-inch metal lathe with the tail stock and tool post removed and the motor changed to reduce the lathe's minimum speed. A water tank was added to allow the chuck to rotate the piece being tested under water, and a transducer drive mechanism was added to the tool post carriage. In addition to this, various devices were incorporated to drive the read-out circuitry. The tester was designed primarily to inspect end-cap welds on heat sources, but it will also measure wall thickness and locate cracks and defects. To do this, it utilizes a conventional ultrasonic pulse echo system. An oscilloscope is used to indicate the size and location of the ultrasonic echoes, while the wall thickness or wall defects and weld penetration may be plotted on an X-Y recorder. Relative transducer location is indicated in the longitudinal and transverse direction to the nearest thousandth of an inch.

## PRINCIPLE OF OPERATION

The system operates on the ultrasonic pulse echo principle. A lithium sulphate piezoelectric transducer is excited with a fast rise electrical pulse. The transducer then propagates this high energy pulse through a water coupling medium to the surface of the fuel element being tested, and after a short time, an echo is received. The presence or absence of an echo indicates the integrity of the weld being tested, or, in the case of a wall defect, the presence or absence of a crack. If the tester is being used to measure the fuel element wall thickness, the time difference between a front and back surface echo determines the thickness of the wall.

## TESTER DESCRIPTION

The isotope heat source tester shown in Figure 1 consists of the following components:

- Pulse generator
- Signal processing unit
- Pulse logic system
- Transducer position indicators
- X-Y recording system
- Time measurement system
- Power supply
- Motor control panel
- Lathe

Individual views of the transducer bridge and of the electronic console are shown in Figures 2 and 3 respectively.

## PULSE GENERATOR

The pulse generator is shown on the left side of Figure 4. The wave forms from the pulse generator are shown in Figure 5a. The positive sync signal received from the digital logic drives a 2N2219 emitter follower, which in turn drives a 2N3501. This latter transistor is operated in its avalanche mode with about 250 V on the collector. When the sync pulse is received, the 2N3501 is driven into avalanche and switches the 1000 pF capacitor to ground and produces a negative 150 V pulse with a 10 nsec risetime. This pulse is transmitted down the coaxial cable to the ultrasonic transducer, which then propagates the ultrasonic pulse towards the isotope heat source being tested.

## SIGNAL PROCESSING

### Amplifiers

The echoes received from the transducer are amplified by a wide-band preamplifier located on the lathe transducer drive mechanism. This amplifier, a C-COR No. 3582, has a gain of about 10 and is used to drive the cable between the lathe and the electronic console. The two Q6-100 diodes connected to ground at the input of the preamplifier are used to protect the input from the 150 V transmit pulse.

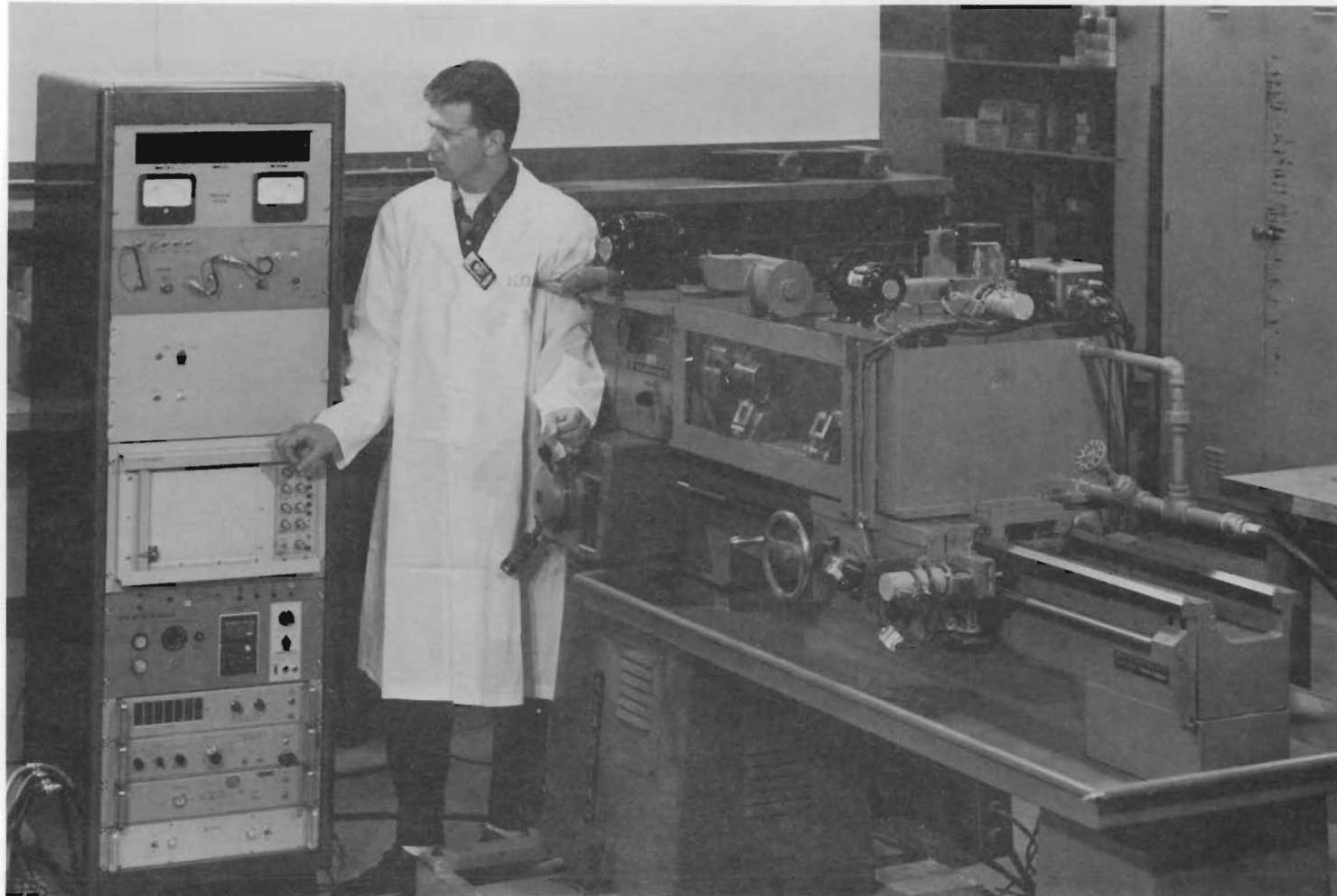

FIGURE 1. *Isotope Heat Source Tester*

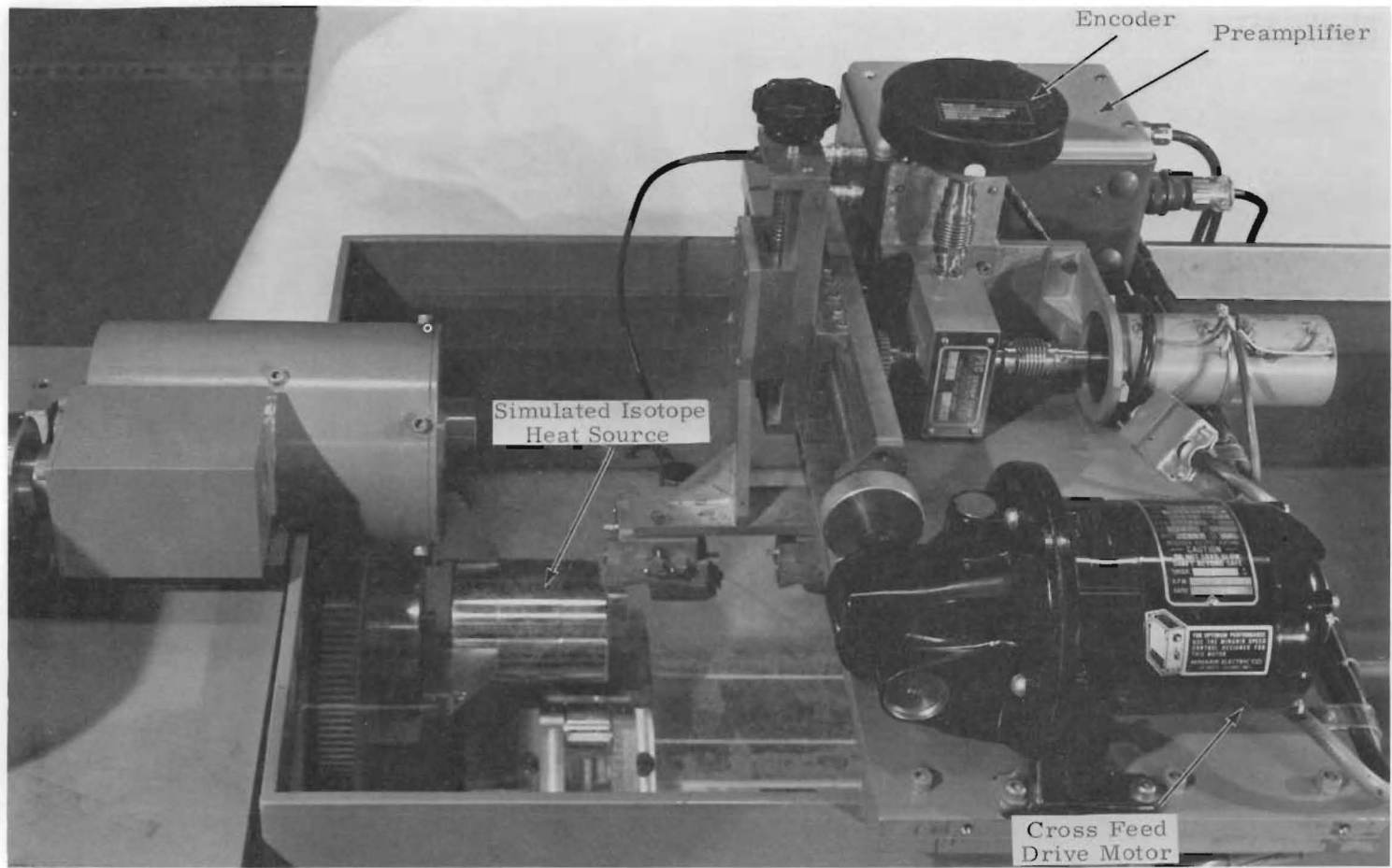

FIGURE 2. *Isotope Heat Source Tester - Transducer Bridge*

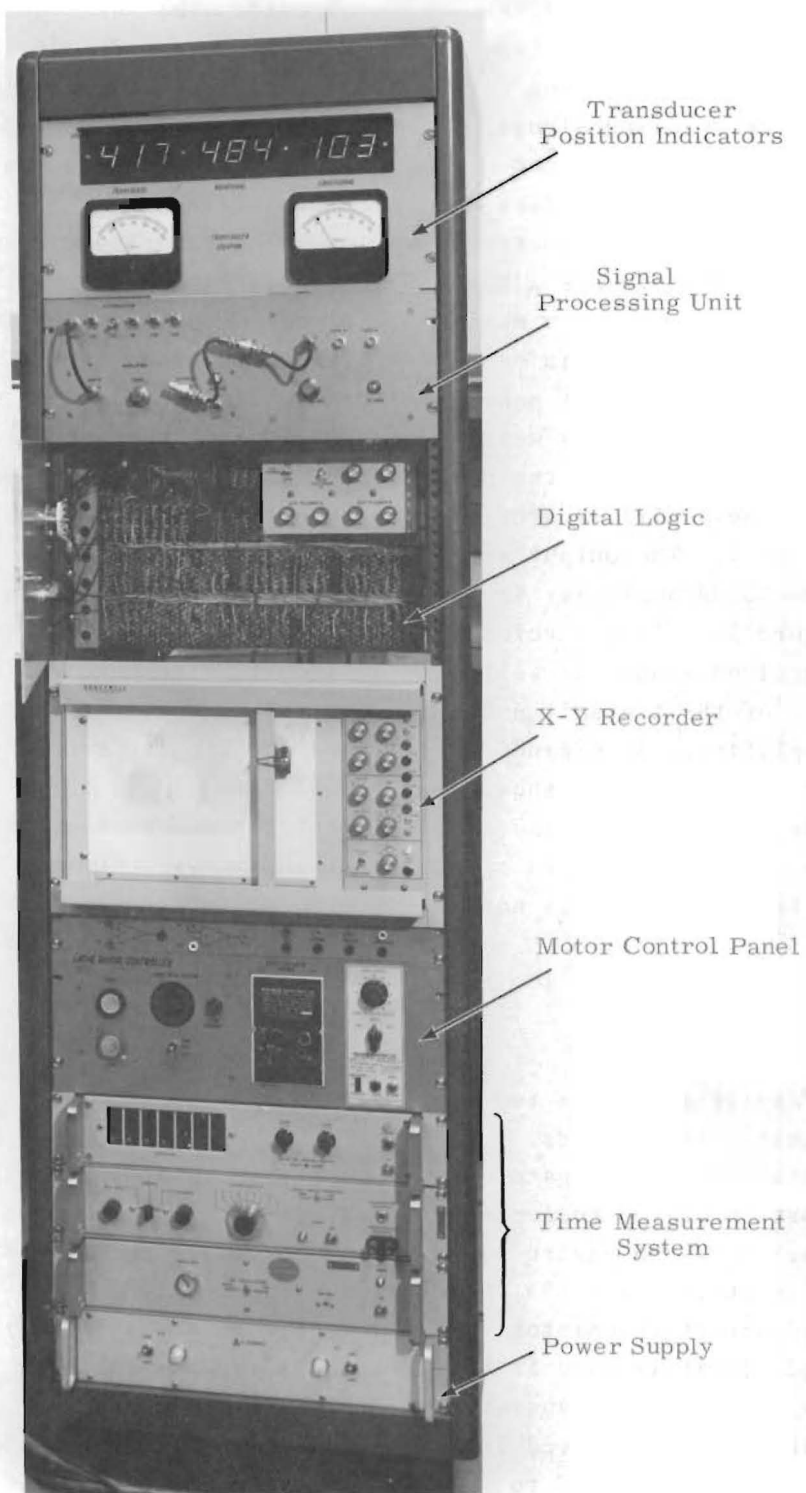

FIGURE 3. Isotope Heat Source Tester - Electronic Console

The signal cable from the preamplifier is connected to an attenuator which is used to vary the amplitude of the incoming signal. The attenuator, in turn, is connected to an RHG GT50B amplifier located in the top of the electronic console. This amplifier has a maximum gain of about 55 dB and a maximum output of  $\pm 3$  V. The gain can be varied 15 dB with a front panel control. The attenuator, as well as the interconnection from the preamplifier and the amplifier are shown on Figure 4. The output waveform from the 55 dB amplifier is shown in Figure 5c. This waveform shows the received echoes as well as the effect of the transmit pulse on the preamplifier. An expanded version of this waveform is shown in the top of Figure 6a. This figure shows only the received echoes--the transmit pulse is not visible.

#### Signal Gate

The main amplifier drives two separate signal gate circuits. These circuits are used to gate out a certain portion of the reflected echo signals. Shown on Figure 4, these circuits utilize a U-183, N-channel field effect transistor. The amplified signal is used as the drain supply to this FET transistor while the gate signal, derived from the logic circuitry, is used to drive the FET gate terminal. Since no other drain supply voltage is used, no pedestal is encountered on the output taken from the FET source

circuit. The FET requires a -15 V signal to turn it off, but only -3 V is available from the logic circuitry, so a 2N1132 PNP transistor is used to generate the -15 V to 0 V pedestal necessary to turn the FET on. The gate input waveforms can be seen in Figure 6a, while the gated signal output is seen in Figure 6b. The output from the FET goes to a 1N100 detector circuit, using a 100 k $\Omega$  resistor and a 130 pF capacitor as a filter. The small detected output from this circuit is amplified in a second C-COR 3582 amplifier (Figure 6d) and is used to drive the peak reader and alarm circuit. In addition to this, the output of the FET feeds a 2N709 avalanche pulse generator through a 2N1132 switch circuit. This generator produces the very fast rising pulse necessary to turn the time measurement scaler on and off. The output of this pulse generator is shown in Figure 6c.

#### Peak Reader and Alarm Circuit

The peak reader and alarm circuit, shown at the bottom of Figure 4, is used to produce a dc output proportional to the peak value of the input pulse. A Q6-100 diode rectifies the output of the 3582 amplifier and feeds it to a very high impedance voltage follower circuit with a voltage gain of 1. The output of this voltage follower circuit drives both the recorder circuit and an alarm circuit. This alarm circuit as well as the voltage follower both utilize Nexus



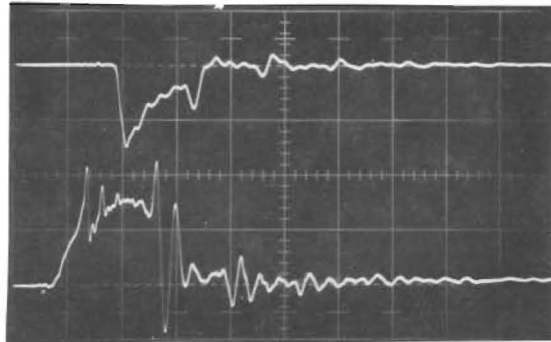

(a) Upper - Transmit Pulse at Preamp.  
 100 V/cm  
 Lower - Sync Pulse  
 2 V/cm  
 0.1  $\mu$ sec/cm

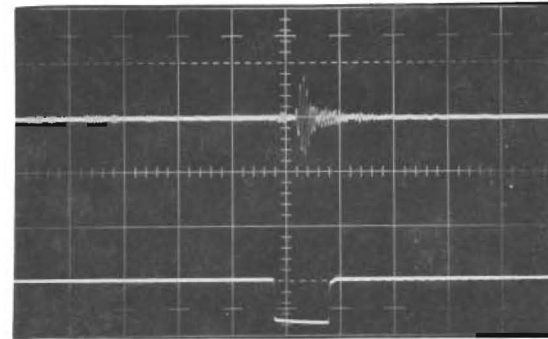

(b) Upper - Amplifier Output, Shear Crack  
 Test  
 2 V/cm  
 Lower - Normal Gate A  
 5 V/cm  
 1  $\mu$ sec/cm

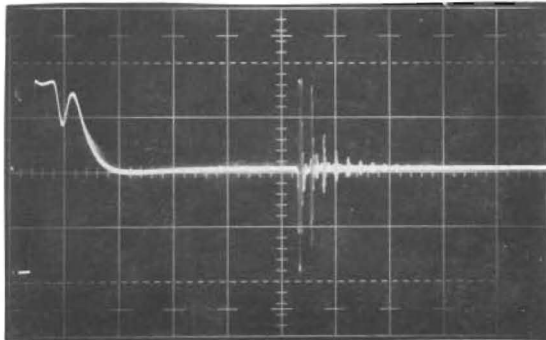

(c) Signal Output after Amplifier,  
 Conventional Pulse Echo  
 2 V/cm, 10  $\mu$ sec/cm

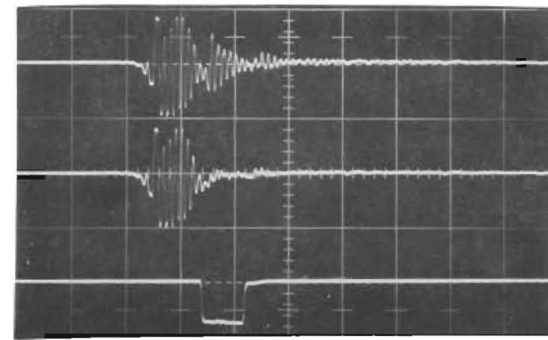

(d) Upper - Amplifier Output, Weld Test,  
 Poor and Good Penetration  
 Lower - Normal Gate A  
 5 V/cm, 1  $\mu$ sec/cm

FIGURE 5. Oscilloscope Waveforms

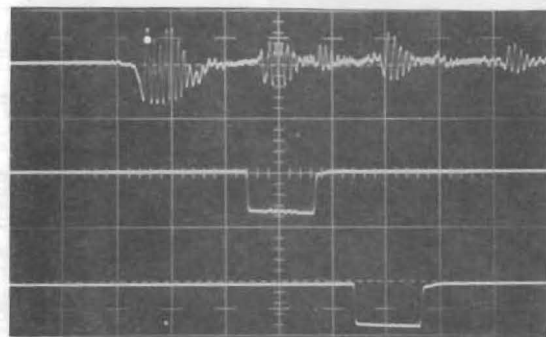

(a) Upper - Amplifier Output, Thickness Test  
 Lower - Gate A and Gate B  
 5 V/cm, 1  $\mu$ sec/cm

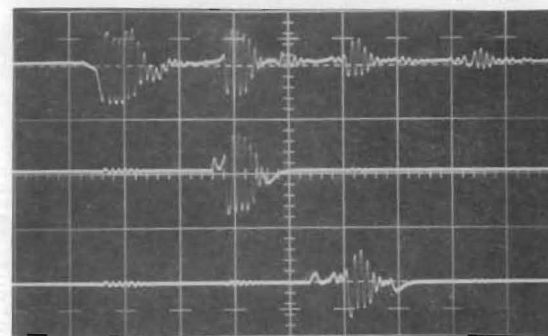

(b) Upper - Amplifier Output  
 5 V/cm  
 Lower - Gated Output A and B  
 1 V/cm, 1  $\mu$ sec/cm

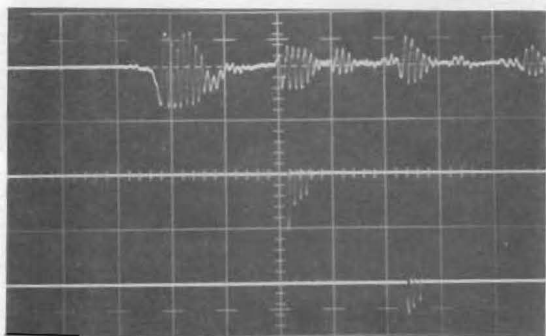

(c) Upper - Amplifier Output  
 Middle - Counter Start Pulse  
 Lower - Counter Stop Pulse  
 5 V/cm, 1  $\mu$ sec/cm

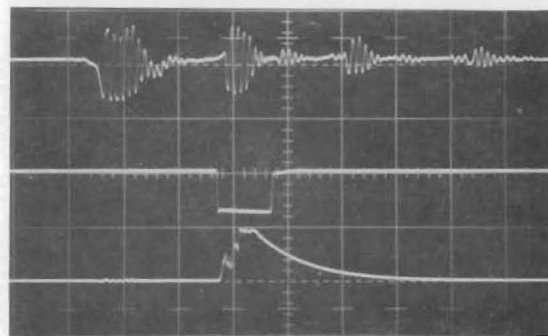

(d) Upper - Amplifier Output  
 Middle - Gate A  
 Lower - Detector (3582) Output  
 5 V/cm, 1  $\mu$ sec/cm

FIGURE 6. Oscilloscope Waveforms

SQ1 operational amplifiers. The alarm circuit operating as a level switch feeds a 2N3638 transistor switch which drives an alarm light. The switching level of the operational amplifier is set by a front panel potentiometer.

In the ideal case the dc peak output should be directly proportional to the peak value of the pulse. Because of the oscillatory nature of the pulse, however, this is only approximately true. The rectifying diodes are not perfect and will not charge the filter capacitors in only one cycle; consequently, the dc peak output is somewhat dependent on the number of oscillations applied to the detector. In addition to this, a small amount of the gate pulse may feed through to the detecting circuit preventing the circuit from operating properly on small signals.

#### Operational Amplifier Board

The operational amplifier board is used to combine signals for the X-Y recorder. It contains two operational amplifiers, both with a gain of 1. The output from both these amplifiers goes to the recorder panel where they may be patched into the recorder as desired. The inputs to these amplifiers also go to the recorder panel where they may be connected to the transducer location potentiometers when necessary. This board uses Nexus SQ1 operational amplifiers with 10 k $\Omega$  input and feedback resistors. Their maximum output voltage is 10 V at 1 mA.

The primary purpose of these amplifiers is to combine either the peak pulse output or the pulse time analog output with the transducer location signals.

#### PULSE LOGIC SYSTEM

The pulse logic circuitry for the tester performs the following functions:

1. Provides a clock pulse for the system.
2. Receives ultrasonic echoes and generates gates for the signal gate circuits.
3. Provides delay circuitry to adjust the width and location of the output gates.
4. Generates a signal to lift the X-Y recorder pen.

The circuitry for the pulse logic system is shown on Figure 7.

The logic circuitry is made up of digital modules located in plug-ins behind the front panel. Diode transistor logic is used with -3 and 0 V logic levels. The clock, shown on the left in Figure 7, generates a synchronizing pulse for the entire tester. A front panel switch controls the frequency of this clock. In the fast position, it generates approximately 3000 pulses per second used for viewing with the oscilloscope; while in the slow position, only 10 pulses per second are generated. This slow position is used when the time measuring system is in operation. In the single pulse position, only one pulse is generated when the accompanying button is depressed.

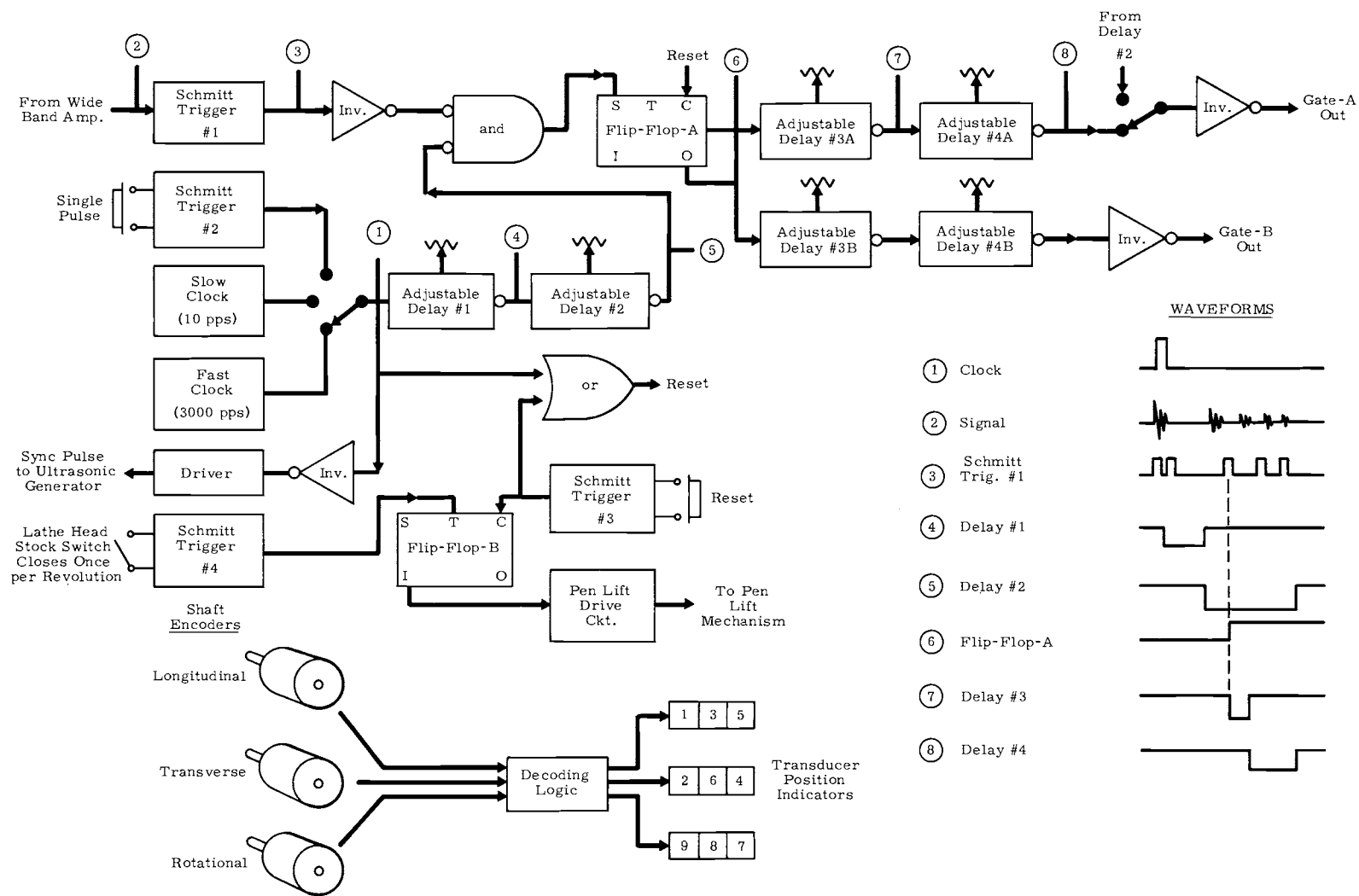

FIGURE 7. Logic Diagram

The output from this clock, shown in Figure 8d, is used to drive the ultrasonic pulse generator, and delay circuit No. 1. The delay circuit generates a delay lasting for approximately the length of the transmit pulse and the disturbance caused by this pulse. At the completion of this time, the circuit actuates delay No. 2, shown in Figure 8b, which allows the front surface echo to trigger flip-flop A (FF-A). This flip-flop drives delay circuit 3a and 3b which in turn actuate delay circuits 4a and 4b. Both these circuits generate a gate whose time is dependent on the arrival of the front surface echo. Delay No. 3 adjusts the time between the surface echo and the start of the gate, while delay No. 4 adjusts the width of the gate. They are shown, along with FF-A in Figure 8c. A switch permits switching to a normal gate, which is merely the output of delay No. 2, allowing this gate to be used for the front surface reflection if desired. All the delay and width adjustments as well as this switch are available immediately behind the front panel of the digital logic section.

In addition to this gate circuitry, a pen lift circuit is shown in the bottom section of the drawing. A microswitch located on the head stock of the lathe closes once per revolution of the part being tested. This switch, connected to the Schmitt trigger #4, drives flip-flop circuit B and the pen lift circuit. The pen drive circuit in turn lifts the pen during one revolution and actuates the pen during the succeeding revolu-

tion, permitting the pen to be driven back across the paper during this non-writing cycle.

#### TRANSDUCER POSITION INDICATORS

The transducer position indicators indicate the transducer location to the nearest thousandth of an inch in both the longitudinal and transverse directions. They also indicate the rotational position of the fuel element to the nearest thousandth of a turn. This is done by digital shaft encoders geared to the cross feed and to the longitudinal feed of the lathe as well as one driven from the head stock shaft. Since the transverse and longitudinal encoders produce one thousand counts for each inch of travel, an auxiliary system to indicate the number of inches from a zero reference point is needed. This secondary position indication is accomplished by utilizing potentiometers also geared to the longitudinal and transverse feed mechanism. These potentiometers drive voltmeter circuits located just under the encoder position indicators on the electronic console.

Because of the ambiguity involved in digital shaft encoder brush mechanisms, a special binary code is used in the encoders on this tester. These encoders have one thousand discreet positions indicated electrically through 12 output lines. Each output line is connected to a brush which rides on the encoder discs. This special code is converted to the seven line indicator code through a logic decoding system not detailed

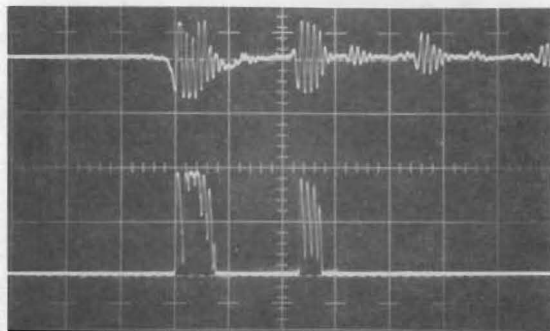

(a) Upper - Amplifier Output, Thickness Test  
 5 V/cm  
 Lower - Schmitt Trigger A10L Output  
 2 V/cm, 1  $\mu$ sec/cm

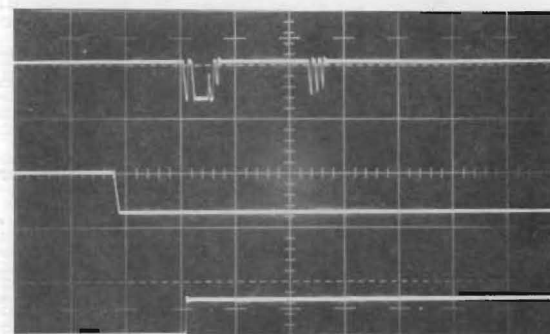

(b) Upper - Inverter A10U Output  
 Middle - Delay Number 2  
 Lower - Flip-Flop A  
 5 V/cm, 1  $\mu$ sec/cm

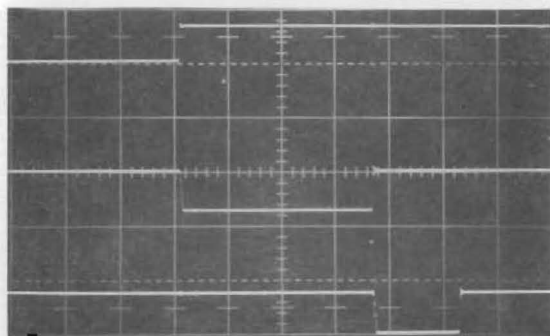

(c) Upper - Flip-Flop A Output  
 Middle - Gate Follower Delay  
 Lower - Gate Follower Width  
 5 V/cm, 1  $\mu$ sec/cm

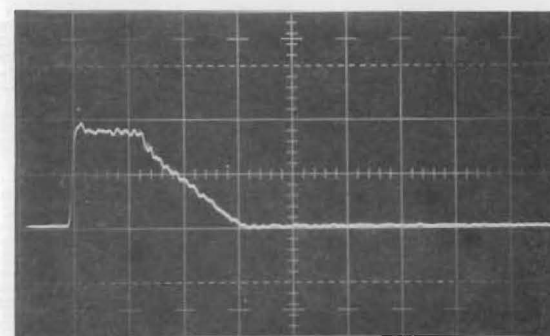

(d) Clock A3U, 2 V/cm  
 0.1  $\mu$ sec/cm

FIGURE 8. Oscilloscope Waveforms

here. The seven line indicators can be seen on the top of the console in Figure 3.

#### X-Y RECORDING SYSTEM

A conventional X-Y recorder system to map out the test results is provided with this tester. This recorder, a Honeywell Model 320 TM, is a dc type with a separate servo drive system for both the X and Y direction. Associated with this recorder is the recorder drive panel. This is a patch panel permitting connection of either the X or the Y pen drive to any one of a number of inputs. Signals from the longitudinal and transverse transducer location or the rotational position of the fuel element being tested are obtained from precision potentiometers mounted on the lathe. Any one of these location detectors can be connected to either pen servo of the recorder. In addition to the outputs from the potentiometers, both the inputs and outputs of two operational amplifiers are also available on the recorder panel. These amplifiers permit adding almost any combination of signal and transducer location information for the special recorder plots explained later. The primary purpose of this recorder panel is to permit versatile connection to the recorder inputs. It is possible, for example to plot longitudinal transducer position plus weld defect in the X direction, and fuel element rotational position in the Y direction. A variation of this plot resulting in a somewhat isometric representation may be obtained

by combining the longitudinal and rotational motions for the X recorder input.

#### TIME MEASUREMENT SYSTEM

The fuel element wall thickness may be determined by measuring the time difference between the front wall surface and back surface reflections. This is done by setting one of the signal gates on the first pulse, and the second one on the second pulse. The same measurement may also be obtained by using the first and second reflection of the back surface as shown in Figure 6a, b, c. As previously mentioned, the output of these two gates then drive two pulse generators. These pulse generators are made to turn on and turn off a 100 MHz counter. This counter receives the output from a 1 MHz oscillator, multiplies it to 100 MHz, and counts the number of cycles between the two pulses. The output from the counter is connected to a digital to analog converter, which permits analog plotting of this time difference on the X-Y recorder.

The counter, mounted in the lower section of the electronic console, is a Hewlett-Packard Model 5275A time interval counter. Since it counts 100 MHz oscillations, its time resolution is 10 nsec. The counter reads out directly in microseconds. Because of the 10 nsec resolution, the start-stop pulse requirements are rather stringent. For this reason, it was necessary to use a fast rise avalanche pulse circuit. While the ultrasonic information is probably not accurate

to 10 nsec, it is comforting to know that the counter will count with this resolution. The oscillator driving this counter is a Hewlett-Packard Model 101A, crystal controlled, 1 MHz oscillator. This 1 MHz signal is stepped up to 100 MHz through a series of frequency multipliers within the counter. The digital to analog converter, a Hewlett-Packard Model 580, converts any three adjacent digits from the counter to an analog output.

#### POWER SUPPLY

The power supplies required for this tester include two ac supplies and four separate dc supplies. One 15 A, 115 V ac supply is required for the lathe motors and the controller, while a second 15 A, 115 V ac supply is required for the electronic test equipment. This supply may be conventional ac power without special regulation, but must be free from transients and noise. The dc supplies include one 15 V, 1 A supply for the transducer location lights. This actually consists of two separate Lambda Model LM 206 modular supplies in parallel. In addition to this, two other Lambda supplies furnish  $\pm 15$  V at 1/2 A for general console circuit requirements. A special-built high voltage supply is required for the ultrasonic pulser. It is an unregulated adjustable 150 to 350 V positive supply. This adjustment feature is necessary since the avalanche point of any two 2N3501 pulser transistors is not the same.

#### MOTOR CONTROL PANEL

The motor control panel mounted on the lower section of the electronic console controls the three motors on the lathe.

1. The three-quarter horsepower lathe drive motor
2. The one-twelfth horsepower chuck drive motor
3. The one-fiftieth horsepower cross-feed drive motor

These motors are dc shunt wound motors with SCR variable speed controllers. The controllers for the two smaller motors are mounted directly behind the motor control panel on the console, while the controller for the large three-quarter horsepower lathe drive motor is mounted below the lathe head stock.

The cross-feed motor is controlled by its SCR controller and contains no special interconnection or circuitry. The one-twelfth horsepower lathe chuck motor controller, however, has been altered so that it is controlled by a spring return, push button switch. This prevents the motor from operating unless the push button is being actuated. In addition to this, a cross connection to the three-quarter horsepower controller prevents operating the chuck motor when the lathe is operating. Both these controllers contain their own forward-reverse switches. Because of the size of the lathe motor, however, reversing is done by external relays.

The speed of the lathe motor is variable between 60 and 1800 rpm.

This results in a spindle speed of about 1.5 to 46 rpm, with the lathe back gear engaged. Limit switches on the longitudinal travel of the lathe, stop the drive motor at the ends of the travel. Start-stop switches, a red running light, a forward-reverse switch, and a speed control potentiometer are located on the electronic console for the lathe drive motor. The controller itself is located under the lathe head stock.

#### THE LATHE

The mechanical heat source rotating device is a standard 14 in. Clausing Model 6913 lathe with the tail stock and tool post removed. A water tank was added to allow the chuck to rotate the fuel piece under water. A redesigned chuck utilizing an electric drive motor and a pneumatic cylinder engaging mechanism was added to permit remote chuck operation. In addition to this the drive motor was changed to permit slower spindle speed.

An ultrasonic transducer drive mechanism was attached to the tool carriage permitting the lathe longitudinal drive system to position the transducer as desired. A small cross feed drive motor was added to permit easy location of the transducer in the transverse direction. Dual potentiometers for the transducer position indicating system and the recorder X-Y drive mechanism were added to both the longitudinal and cross feed systems. A single turn potentiometer was coupled to the lathe spindle, also for recorder drive.

Three, single turn, shaft encoders were coupled to measure both transverse and longitudinal transducer motion and rotational spindle location.

Limit switches were added to the longitudinal feed and an interruption switch added to the chuck. This latter switch controlled the up and down position of the recorder pen. The potentiometer on the lathe spindle rotates once for each two rotations of the spindle. Thus, the recorder pen is down for one rotation and up for the next.

Figures 1 and 2 show the lathe water tank with plastic window to permit viewing. The tank equipped with both inlet and overflow outlet can be supplied continuously with cooling water to cool the isotope heat source being tested. Figure 2 shows the transducer locating bridge with the transducer attached immediately above the fuel element. On the far side of the bridge is also seen the preamplifier and switch box. This switch controls which transducer is the transmitter and which the receiver.

#### TESTER OPERATION PROCEDURES

The tester has been designed to produce several different types of readouts, but the results are not limited to those shown here. Examples and arrangements for four different tests are included in the following:

- Porosity and weld penetration on a SNAP-21 simulated capsule.
- Longitudinal cracks of varying dimensions on the outside of a cylindrical sample.

- Wall depth of a variable thickness cylindrical ring.

It should be noted that these tests are not easily performed. The utmost care was exercised in the initial adjustment of the equipment so that the optimum transducer signal could be obtained. In every case the transducer direction and orientation were adjusted and readjusted to insure optimum response. In addition to this, it was determined that a minimum amount of noise from both internal and external equipment was entering the system.

The sample to be tested was inserted into the specially designed lathe chuck. This was done by first actuating the pneumatic cylinder to engage the clutch gears. Then, with the lathe drive gears engaged, the chuck motor button actuated the chuck motor to either open or close the chuck. With the sample in the chuck, the air cylinder was deactuated and the lathe operated in its normal fashion. Support rollers on the bottom of the lathe water tank may be adjusted to aid in supporting a particularly long sample.

This tester was designed to perform a number of different tests, hence a certain degree of flexibility was built into it. For this reason a different interconnection was necessary for each test. Two transducer motions plus the sample rotation are converted to electrical signals. Any one or a combination of these plus the ultrasonic pulse amplitude are available for connection to the recorder. To combine these signals, two operational summing amplifiers

with a gain of one have been provided with connections available on the recorder panel. These must be patched in according to the test to be run.

#### POROSITY AND WELD PENETRATION

Figure 9 shows the test arrangement for both the weld quality and crack test. Figure 10 shows the results of a weld quality test on a simulated SNAP 21 isotope heat source. The tester was set up for conventional pulse echo signals with the transducer at right angles to the sample. Gate A was adjusted to bracket the area of suspected defect similar to that shown in Figure 5d. Any signal appearing within this gated area actuated the peak reader and was recorded on the recorder. Figure 11 shows a cross section of the SNAP 21 capsule weld. It will be noted that lack of weld penetration results in a machined surface as seen below the transducer in Figure 11. The presence of this surface is shown in the upper trace of Figure 5d while the middle trace shows no reflection in the area bracketed by gate A. If the weld penetrates to the shoulder area of the cap, no reflection will be seen. Porosity presents a similar but usually smaller signal. Also, if the porosity occurs to the left of the shoulder, a rear wall reflection will be seen and the gate must be adjusted to eliminate this unwanted signal.

Figure 9 shows the connection necessary to produce the isometric type recording seen in Figure 10. In order to produce this, a portion of the rotational signal must be applied

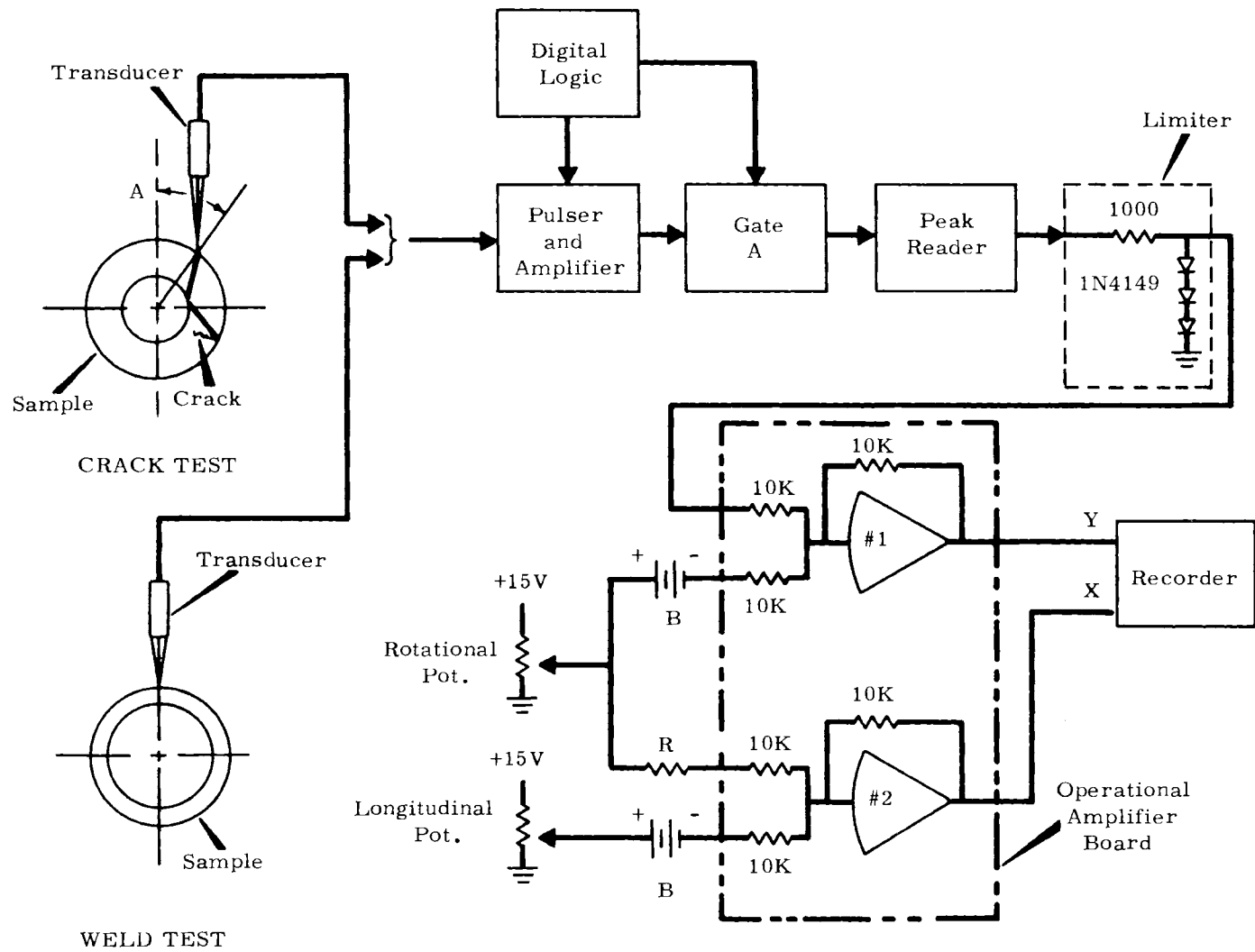

FIGURE 9. Test Arrangement, Crack and Weld Test

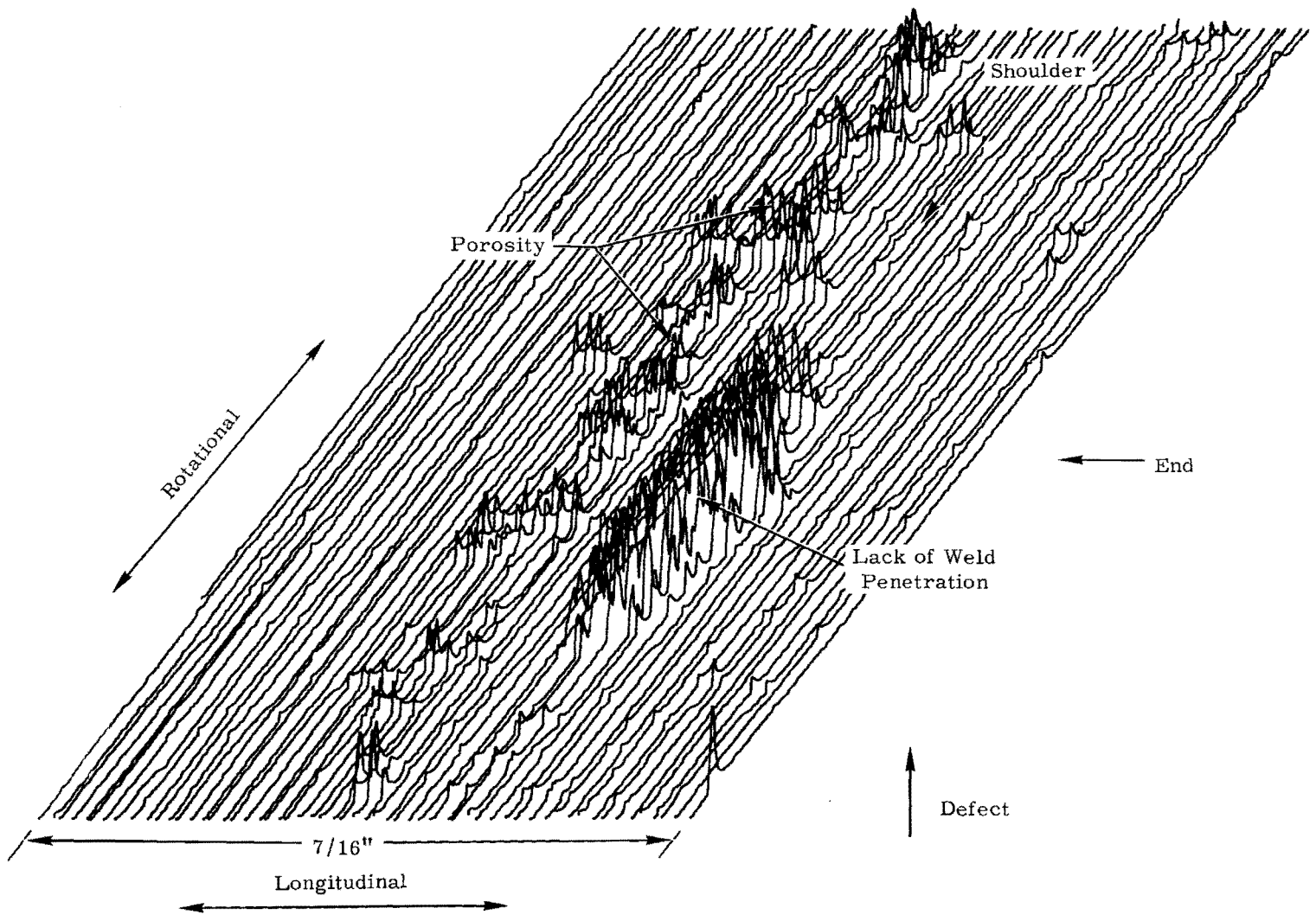

FIGURE 10. Simulated Snap 21 Fuel, Capsule 8, End 11, Weld Test

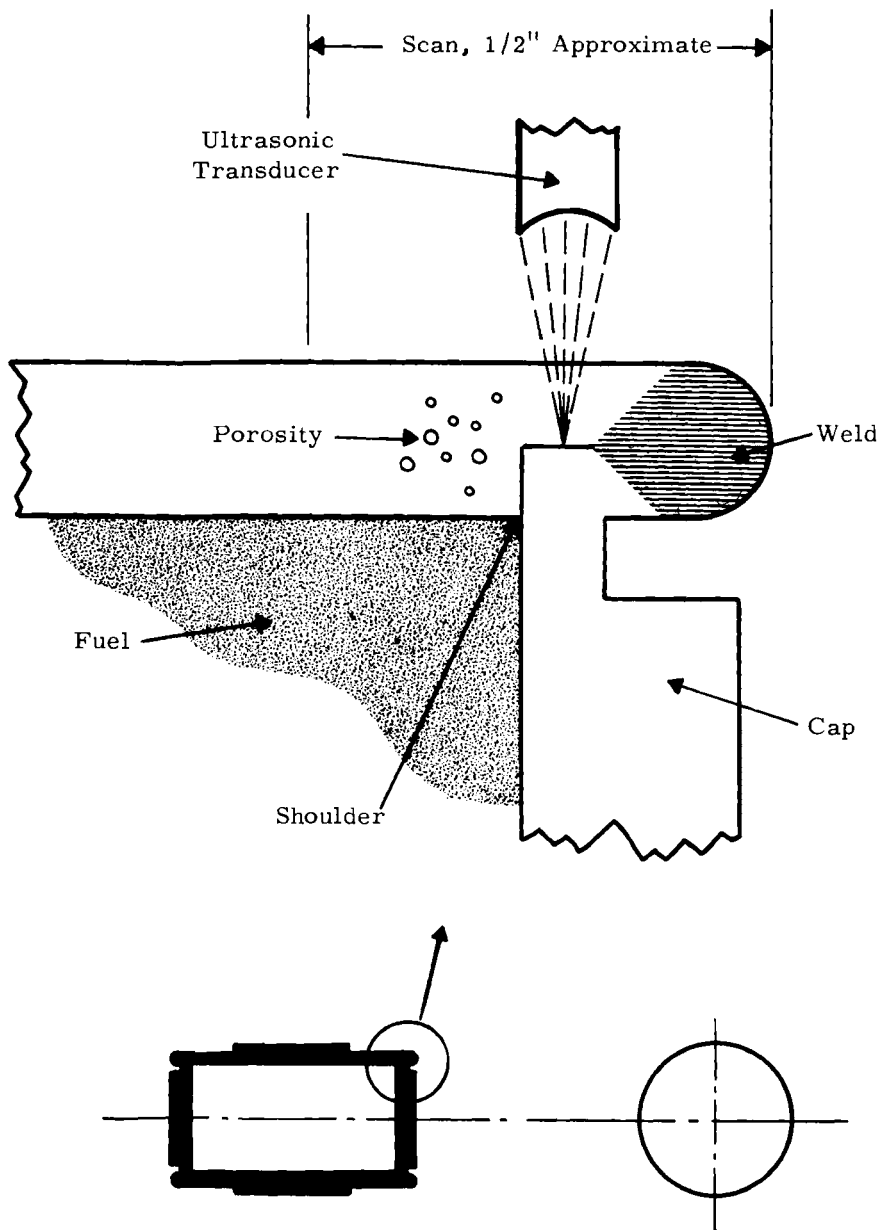

FIGURE 11. Simulated Snap 21 Fuel Capsule

to both the X and Y channels of the recorder. These must also be combined with the longitudinal signal and the peak reader output through the operational amplifiers before recording. This produces the results shown -- with the longitudinal in the X direction, the rotational in the oblique

direction, and the peak output or defect in the Y direction. The recorder gain is variable, but it is necessary to adjust the ratio of rotational to longitudinal signal transmitted to the recorder X axis. This was done by adding the series resistor, R shown in Figure 9. To obtain the graph of

Figure 10, R was 330,000  $\Omega$ . The limiter shown in Figure 9 was used to clip the peak amplitudes of the peak reader output and prevent large pen excursions in the Y direction.

Figure 12 shows the interconnection for the same weld quality test described in the previous section but with a conventional X-Y readout. This produces a more orthographic recording. The longitudinal displacement is plotted in the X direction while the rotational position is on the Y axis. The defect is then superimposed on the X displacement. The results of this type of test are shown in Figure 13. This is not the same fuel capsule shown in Figure 10 but is the same type test. Evidence of porosity and possibly cracking can be seen around the area of the shoulder.

#### LONGITUDINAL CRACKS

Figure 9 also shows the interconnection for locating longitudinal cracks in a cylindrical sample and Figure 14 shows the results of a crack test on a 2 in. diam by 1/4 in. wall tubing. Cracks were machined in the outside wall to a depth as indicated. The transducer was then set up as shown in the upper left of Figure 9 to produce an echo from the ultrasonic shear wave. In the case of stainless steel and water, angle A is approximately 20 degrees. With a crack sample in the lathe, the transducer position and angle were optimized to produce the best signal. As the sample is being rotated, the reflection will appear to increase and

decrease as the crack enters the region of maximum reflection. Figure 5b shows a crack reflection at its position of maximum amplitude.

Figure 14 shows a scan of 9 15/16 in. section of the crack sample. The crack depth is seen to be approximately proportional to signal amplitude. The limiter was not used in this case. The irregularity of the 0.062 in. deep crack was caused by machining problems resulting from a broken cutter.

#### WALL THICKNESS

The wall thickness of a tubular sample was measured with the arrangement shown in Figure 15. The transducer was set up in the conventional manner at right angles to the sample. The received thickness signal is shown in Figure 8a. Gate A and B were adjusted to bracket the signal as in Figure 6a. The gate board pulse generators then produced the necessary start and stop signal to operate the scaler. The recorder was then operated by the digital to analog converter which receives its signal from the scaler.

The results of this test are shown in Figure 16. This recording was obtained from two sections of an eccentrically bored tubing. The wall thickness of one section varies 0.030 in. while the other varies 0.014 in. It was somewhat difficult to maintain consistent results with this test. The absence of either signal resulted in an erroneous count and consequently drove the pen completely off of the chart. A slight misalignment of the

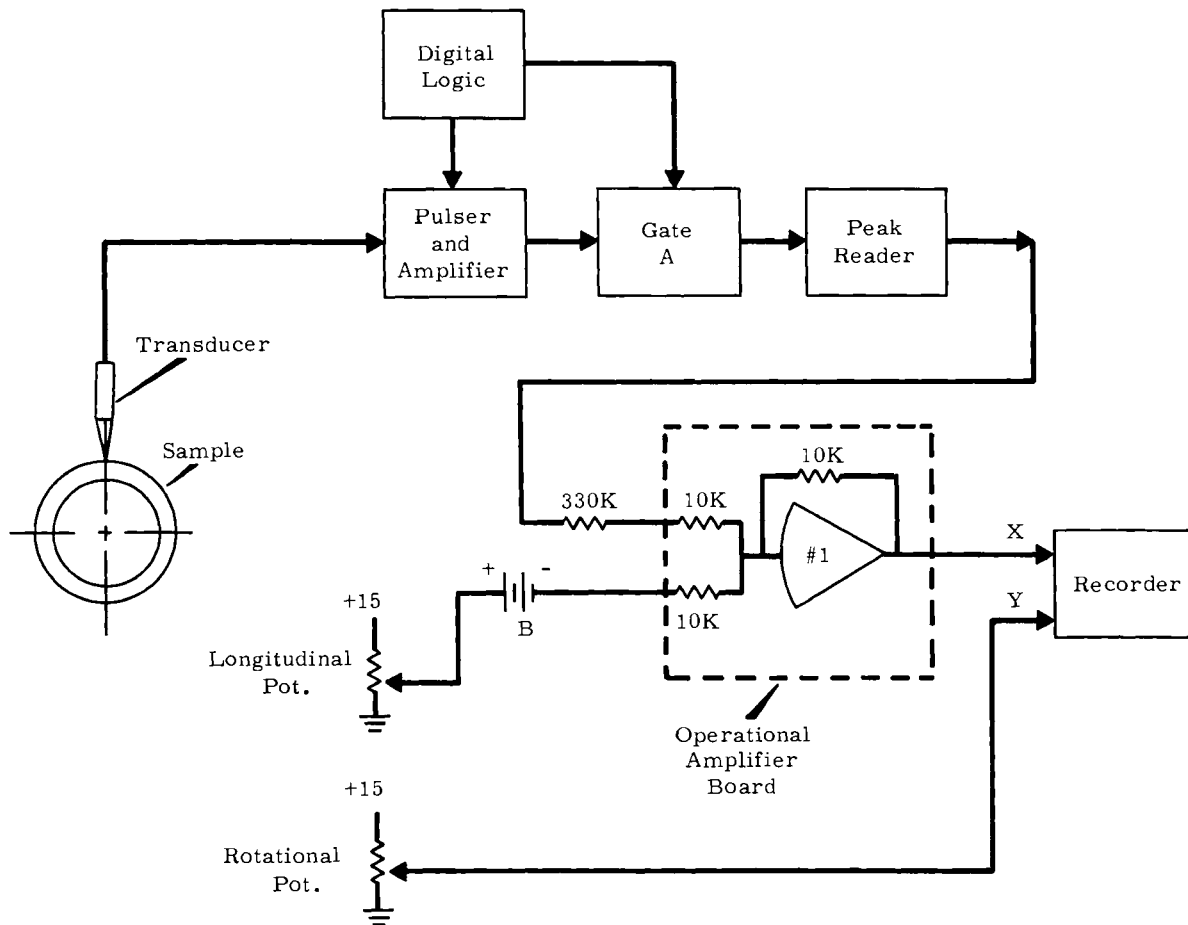

FIGURE 12. Modified Arrangement, Weld Test

transducer also caused a loss of signal. A maximum signal amplitude was necessary to drive the pulse generation circuitry. Frequently, to obtain both the start and stop pulses it was necessary to drive the ampli-

fier into saturation. This caused counter triggering on signal excursions other than the initial rise which of course caused an error in count. The correctly triggered pulse waveforms are shown in Figure 6c.

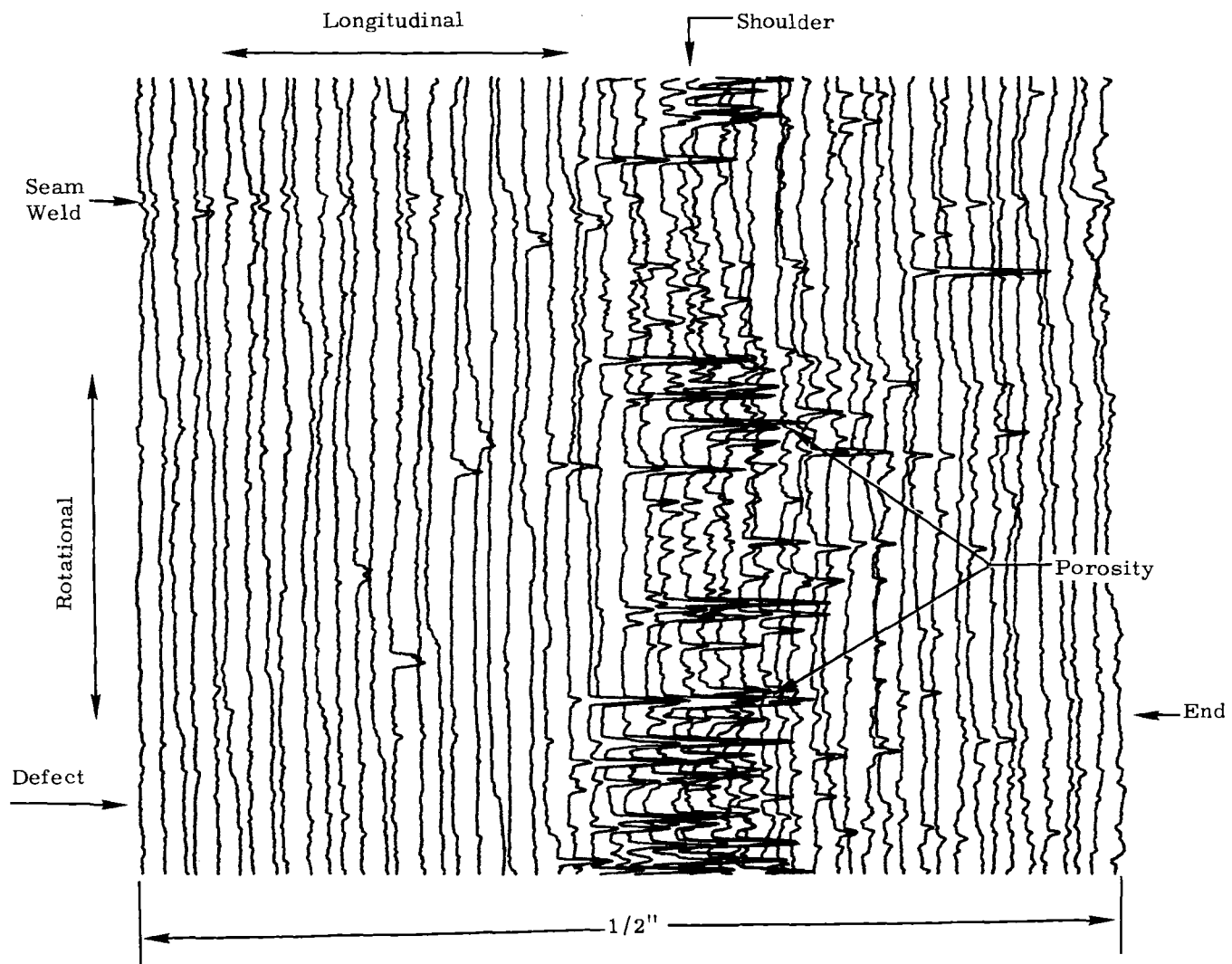

FIGURE 13. Simulated Snap 21 Fuel, Capsule 5, End 10, Weld Test

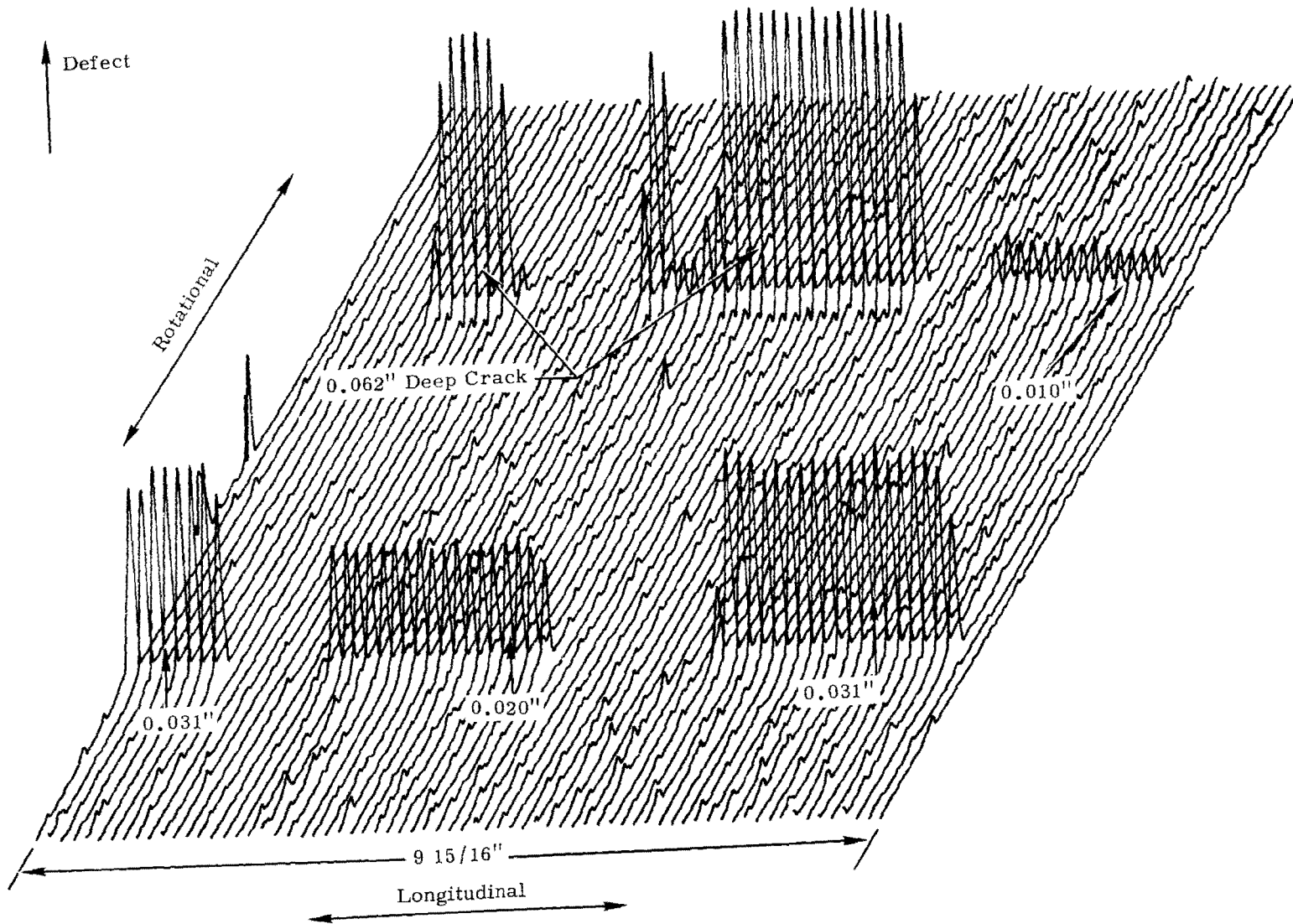

FIGURE 14. Crack Test, 2 inch Diameter x 1/4 inch Wall SST Tubing

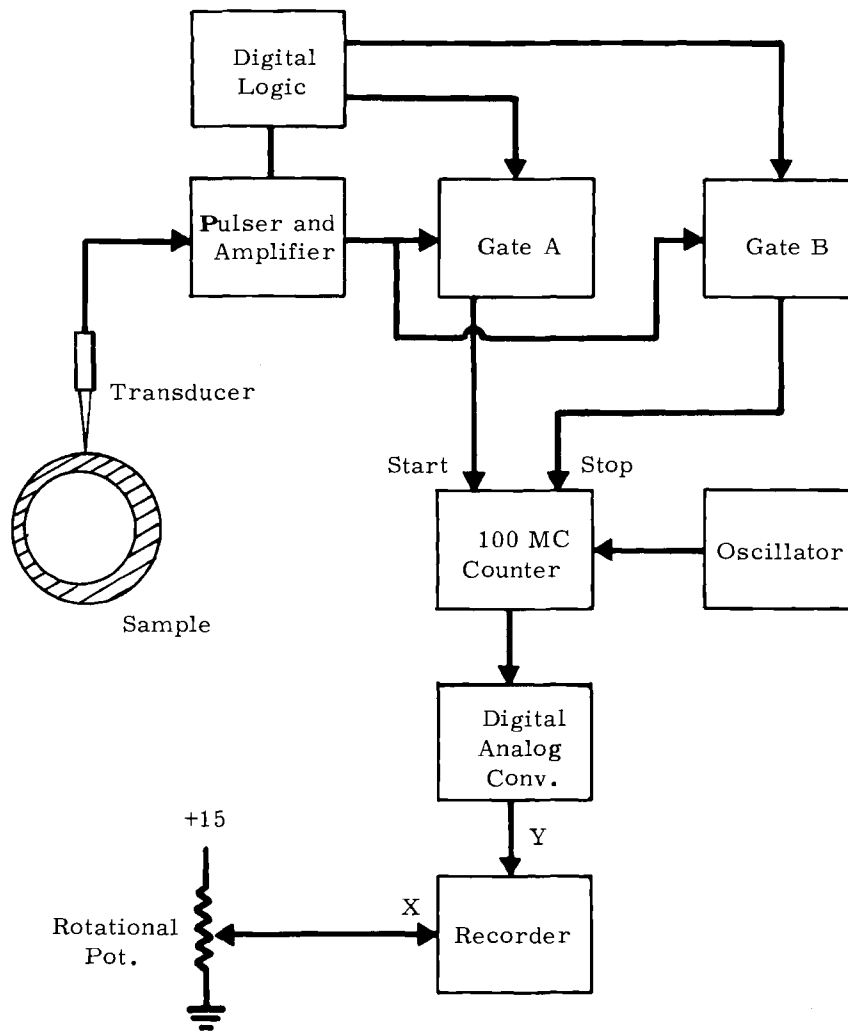

FIGURE 15. Test Arrangement, Wall Thickness Measurement

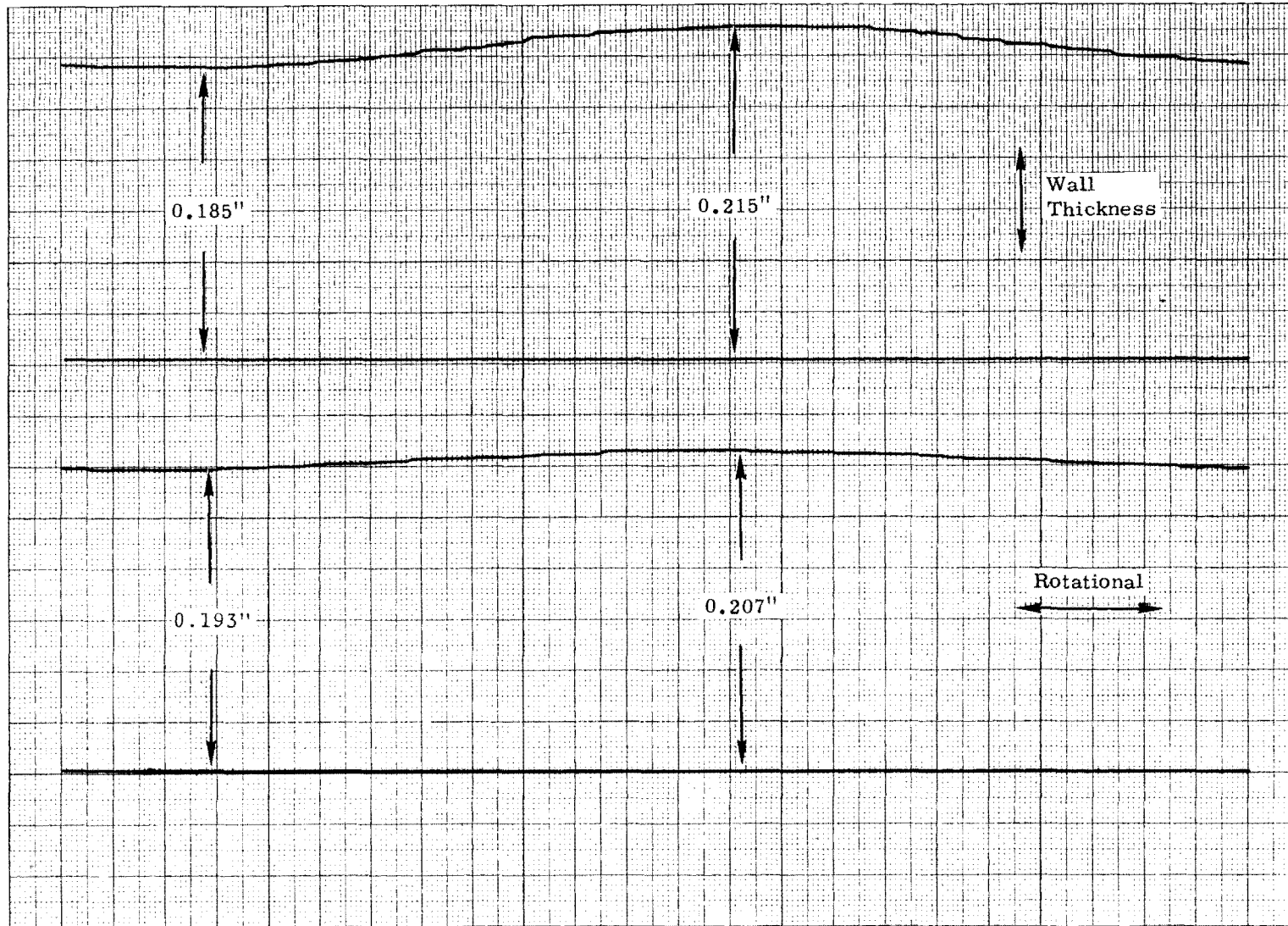

FIGURE 16. Wall Thickness Test, 2 inch Diameter Eccentric, SST Tube

DISTRIBUTION

<u>No. of Copies</u>		<u>No. of Copies</u>	
1	<u>Aerojet General Nucleonics</u> W. G. Ruehle	2	<u>Minnesota Mining and Manufac- turing Company</u> R. L. Panneman Y. Yanisch
237	<u>AEC Division of Technical Information Extension</u>	9	<u>Monsanto Research Corporation</u> Mound Laboratory Miamisburg, Ohio Marion Gray (5) C. M. Henderson (3) P. L. Johnson
9	<u>AEC Library, Washington</u> Division of Isotope Development W. K. Eister G. Y. Jordy J. N. Maddox	1	<u>Oak Ridge National Laboratory</u> R. R. Robinson
	Division of Reactor Development and Technology J. F. Dobson J. S. Griffo W. K. Kern J. A. Lieberman J. A. Powers S. J. Seiken	1	<u>Savannah River Laboratory</u> Savannah, Georgia W. P. Bebbington
2	<u>AEC RDT Site Rep., - PNL</u> P. G. Holsted	1	<u>Westinghouse Electric Corpora- tion (NASA)</u> S. Cerni
3	<u>AEC Richland Operations Office</u> C. L. Robinson Technical Information Library	35	<u>Battelle-Northwest</u> G. M. Dalen C. J. Denton B. E. Dozer (5) G. E. Driver K. Drumheller (2) G. F. Garlick R. J. Hock W. D. Jolly H. N. Pedersen J. C. Spanner (10) W. G. Spear R. W. Steffens E. E. Voiland D. C. Worlton Technical Files (5) Technical Publications (2)
2	<u>AEC Chicago Patent Group</u> G. H. Lee R. K. Sharp (Richland)		
2	<u>Atlantic Richfield Hanford Company</u> W. P. McCue		
1	<u>Brookhaven National Laboratory</u> J. H. Cusack		
2	<u>Douglas United Nuclear, Inc.</u> Files		
2	<u>Hittman Associates, Inc.</u> 9109 Red Branch Road Columbia, Maryland 21043 F. D. Altieri D. E. Goslee		

