

5
-28

2585

Atomic Energy of Canada Limited

URANIUM BOOSTER ROD EXPERIMENTS IN ZED-2

PART I: NEUTRON SPECTRUM PARAMETER MEASUREMENTS

by

P.M. French

Chalk River Nuclear Laboratories

Chalk River, Ontario

November 1972

MASTER

AECL-4260

DISTRIBUTION OF THIS DOCUMENT IS UNLIMITED

DISCLAIMER

Portions of this document may be illegible in electronic image products. Images are produced from the best available original document.

URANIUM BOOSTER ROD EXPERIMENTS IN ZED-2

PART I: NEUTRON SPECTRUM PARAMETER MEASUREMENTS

by

P.M. French

Chalk River Nuclear Laboratories
Chalk River, Ontario

November, 1972

AECL-4260

DISTRIBUTION OF THIS DOCUMENT IS UNLIMITED

yes

URANIUM BOOSTER ROD EXPERIMENTS IN ZED-2

PART I : NEUTRON SPECTRUM PARAMETER MEASUREMENTS

by

P.M. French

A B S T R A C T

Neutron spectrum parameter measurements were performed in the ZED-2 critical facility with four types of ^{235}U boosters. One type was nominally 20% enriched ^{235}U , 4.74 g $^{235}\text{U}/\text{cm}$ length; the other three were 93% enriched with ^{235}U loadings of 2.21 g/cm, 3.49 g/cm, and 4.88 g/cm. The boosters were located interstitially, parallel to reference fuel assemblies. In some experiments, three boosters were inserted in three symmetric configurations that varied the flux coupling between boosters. Measurements were also made with one or three booster assemblies perpendicular to the reference fuel assemblies.

Relative gold-copper, lutetium-copper, or indium-manganese, lutetium-manganese activity ratios were determined in the perturbed regions of the core and interpreted in terms of the Westcott spectral parameters r and T_n or $r\sqrt{T_n/T_0}$.

The results indicate that spectral perturbations are large near the boosters, but do not extend much more than two or three slowing down lengths from the booster sites.

Manuscript prepared June 1972

Chalk River Nuclear Laboratories
Chalk River, Ontario
November 1972

AECL-4260

Expériences effectuées, dans le ZED-2,
avec des barres de surréactivité en uranium

Première Partie: Mesure des paramètres de spectres de neutrons

par

P.M. French

Résumé

Des mesures de paramètres de spectres de neutrons ont été effectuées dans l'ensemble critique ZED-2 avec quatre types de barres de surréactivité en ^{235}U . L'un de ces types était constitué par ^{235}U enrichi à 20%: 4.74 g $^{235}\text{U}/\text{cm}$; les trois autres étaient enrichis à 93% avec des charges de ^{235}U de 2.21 g/cm, 3.49 g/cm, et 4.88 g/cm. Les barres de surréactivité étaient placées parallèlement aux ensembles combustibles de référence. Dans quelques expériences, trois barres de surréactivité ont été insérées dans trois configurations symétriques qui faisaient varier le couplage du flux entre les barres de surréactivité. Des mesures ont été également faites avec une ou trois barres de surréactivité placées perpendiculairement aux ensembles de combustible de référence.

On a déterminé les rapports relatifs d'activité or-cuivre, lutétium-cuivre ou indium-manganèse, lutétium-manganèse dans les régions perturbées du coeur et on les a interprétés en fonction des paramètres spectraux de Westcott r et T_n ou $r \sqrt{T_n/T_0}$.

Les résultats montrent que les perturbations spectrales sont importantes près des barres de surréactivité mais ne s'étendent pas à plus de deux ou trois longueurs de ralentissement des emplacements des barres de surréactivité.

L'Energie Atomique du Canada, Limitée
Laboratoires Nucléaires de Chalk River
Chalk River, Ontario

Novembre 1972

AECL-4260

INDEX

	<u>Page</u>
LIST OF FIGURES	iii
LIST OF TABLES	v
1. INTRODUCTION	1
2. FUEL AND REFERENCE LATTICE CONFIGURATIONS	3
2.1 Reference Lattices	3
2.2 Booster Rods and Suspension Systems	5
3. EXPERIMENTS	16
3.1 General Discussion of Method	16
3.2 Activation Measurements	18
3.2.1 Spectral Parameter Measurements	18
3.2.2 Determination of Activities	21
3.3 Experimental Configurations	22
3.3.1 61-element Booster Measurements	22
3.3.2 Measurements with Interacting Boosters	25
3.3.3 Reference Lattice Measurements	27
4. RESULTS AND DISCUSSION	29
4.1 61-element Booster Results	29
4.1.1 Boosters Parallel to Reference Fuel Assemblies	29
4.1.2 Booster Perpendicular to Reference Fuel Assemblies	41
4.2 Interacting Booster Results	45
4.2.1 Boosters Parallel to Reference Fuel Assemblies	45
4.2.2 Boosters Perpendicular to Reference Fuel Assemblies	47
4.3 Detector Normalization Experiment	51

	<u>Page</u>
5. SUMMARY AND CONCLUSIONS	53
ACKNOWLEDGMENTS	55
REFERENCES	56
APPENDIX A	57
Properties of Neutron Detector Foils	
APPENDIX B	58
Macroscopic Neutron Spectrum Results : 61-element Boosters Parallel to Reference Fuel Assemblies	
APPENDIX C	63
Spectral Perturbation Factor Results : 61-element Boosters Parallel to Reference Fuel Assemblies	
APPENDIX D	65
Neutron Spectrum Results : 33-element and 17-element Interacting Boosters Parallel to Reference Fuel Assemblies	
APPENDIX E	73
Comparison of Neutron Spectrum Detection Methods.	

LIST OF FIGURES

	<u>Page</u>
1. 28-element Natural UO ₂ Cluster	3
2. 52 Rod Square Reference Lattices and Co-ordinate Labelling	4
3. 55 Rod Hexagonal Reference Lattice and Co-ordinate Labelling	4
4. 61-element High Enrichment Booster Cluster	6
5. High Enrichment Booster Fuel Elements	7
6. High Enrichment Booster Suspension System	9
7. 61-element Low Enrichment Booster Cluster	10
8. Low Enrichment Booster Fuel Element	11
9. 61-element Low Enrichment Booster - Horizontal Suspension in ZED-2	13
10. 33-element High Enrichment Booster Cluster	14
11. 17-element High Enrichment Booster Cluster	14
12. Typical Lattice Arrangement with Detectors - 28.58 cm square (D ₂ O) Lattice and 61-element Low Enrichment Booster	19
13. Spectrum Detectors on Aluminum Framework in Moderator	20
14. Lattice Configurations with Three Interacting Boosters Parallel to Reference Fuel Assemblies	26
15. 3, 17-element Boosters - Horizontal Configuration in ZED-2	28
16. $r\sqrt{T_n/T_o}$ SE of Lattice Center : Case 28-10	30

	<u>Page</u>
17. $r\sqrt{T_n/T_o}$ SE of Lattice Center : Case 28-20	30
18. $r\sqrt{T_n/T_o}$ SE of Lattice Center : Case 28-30	31
19. $r\sqrt{T_n/T_o}$ SE of Lattice Center : Case 27-10	34
20. $r\sqrt{T_n/T_o}$ SE of Lattice Center : Case 27-20	34
21. Spectral Perturbation Factors SE of Lattice Center : Case 28-20	39
22. Spectral Perturbation Factors SE of Lattice Center : Case 28-30	39
23. Spectral Perturbation Factors SE of Lattice Center : Case 27-20	40
24. Axial $r\sqrt{T_n/T_o}$: Case 28-40	44
25. Axial $r\sqrt{T_n/T_o}$: Case 28-57	47

LIST OF TABLES

1.	Spectrum Measurement Experiments	23
2.	Measured Neutron Spectrum Parameters in a Lattice Cell - Case 28-10 : 28.58 cm (D ₂ O) Reference Lattice	31
3.	Measured Neutron Spectrum Parameters in a Perturbed Lattice Cell - Case 28-20: 28.58 cm (D ₂ O) Reference Lattice; 61-element 20% ²³⁵ U Booster at K0	32
4.	Measured Neutron Spectrum Parameters in a Lattice Cell - Case 28-30 : 28.58 cm (D ₂ O) Reference Lattice; 61-element 93% ²³⁵ U Booster at K0	33
5.	Measured Neutron Spectrum Parameters in a Lattice Cell - Case 27-10 : 27.94 cm (Air) Reference Lattice	35
6.	Measured Neutron Spectrum Parameters in a Perturbed Lattice Cell - Case 27-20: 27.94 cm (Air) Reference Lattice; 61-element 20% ²³⁵ U Booster at K0	36
7.	Measured Neutron Spectrum Parameters - Comparison of Square Lattice Vertical Booster Results	37
8.	Measured Neutron Spectrum Parameters in Lattice - Case 28-40 : 28.58 cm (D ₂ O) Reference Lattice; 61-element 20% ²³⁵ U Booster Perpendicular Along K at 80 cm Elevation	42
9.	Measured Neutron Spectrum Parameters at Booster Rod - Case 28-40 : 28.58 cm (D ₂ O) Reference Lattice; 61-element 20% ²³⁵ U Booster Perpendicular Along K at 80 cm Elevation	43

	<u>Page</u>
10. Axial Spectral Perturbations, $S(r,z)$ - Case 28-40 : 28.58 cm (D_2O) Reference Lattice; 61-element 20% ^{235}U Booster Perpendicular Along K at 80 cm Elevation	44
11. Measured Neutron Spectrum Parameters - Comparison of Hexagonal Lattice Results	46
12. Measured Neutron Spectrum Parameters in Lattice - Case 28-57 : 28.58 cm (D_2O) Reference Lattice; 3, 17-element Inter- action Boosters Perpendicular	48
13. Measured Neutron Spectrum Parameters at Booster Rod - Case 28-57 : 28.58 cm (D_2O) Reference Lattice; 3, 17-element Inter- action Boosters Perpendicular	49
14. Axial Spectral Perturbations, $S(r,z)$ - Case 28-57 : 28.58 cm (D_2O) Reference Lattice; 3, 17-element Interaction Boosters Perpendicular	49
APPENDIX A	
A-1 Detector Parameters	57
APPENDIX B	
B-1 Macroscopic Measured Neutron Spectrum to Parameters - Square Lattice Vertical B-5 Booster Results	58
APPENDIX C	
C-1 Detailed Spectral Perturbation Factors, to $S(r)$, SE of Lattice Center - 61-element C-3 Booster Results	63

APPENDIX D

D-1	Measured Neutron Spectrum Parameters --	65
to	Hexagonal Lattice Results	
D-8		

APPENDIX E

E-1	Comparison of Various Spectral Parameter Measurement Methods	73
E-2	$r\sqrt{T_n/T_o}$ Values - In/Mn Converted to Au/Cu. Case 28-10 : 28.58 cm (D ₂ O) Reference Lattice	74

1. INTRODUCTION

In an operating power reactor, the production of the neutron poison ^{135}Xe , and its removal through decay and absorption, are balanced at some equilibrium level determined by the neutron flux. When the reactor is shut down, however, the removal of ^{135}Xe through neutron absorption ceases immediately while production from decay of the precursor fission product chain ^{135}Te and ^{135}I decreases more slowly with the half-lives of these isotopes. Therefore, the ^{135}Xe concentration increases rapidly to a maximum in about 10 hours, then decays slowly to the equilibrium level about 30 or 40 hours after shutdown. Similar effects occur with reductions to lower reactor power.

As the fraction of nuclear to total power generated by a utility increases, it becomes more important that a substantial number of power stations have good load following characteristics. Localized, enriched ^{239}Pu or ^{235}U "booster" fuel assemblies are one method currently proposed, or in use in CANDU type power reactors, to provide sufficient excess reactivity for start-up following a short shutdown, or for some measure of load following capability. Boosters, however, are heavy thermal neutron absorbers and strong fast neutron sources, and introduce large flux perturbations in the core. Also, it is now clear that irradiated fuel element sheaths, of current design, will not tolerate significant increases in local power over normal levels, even if maximum allowed fuel rating is not exceeded. If enriched, localized driver fuel assemblies, or boosters, are to be used in future reactors, therefore, it is important that reactor design calculations predict

flux perturbations with a high degree of accuracy.

A number of experimental booster studies have been conducted at Chalk River to provide a standard set of results for comparison with calculation. Recently, Roshd⁽¹⁾ investigated single boosters of three different ^{235}U loading. The results indicated that neither reactivity or flux perturbation effects were proportional to ^{235}U loading due to booster self shielding effects.

This report is the first of a series describing experiments performed in ZED-2 to investigate other uranium booster effects. Recent interest in relatively low enrichment boosters has prompted a series of detailed reactivity and flux perturbation experiments to compare a 20% ^{235}U enriched 61-element booster assembly with a similar 93% enriched assembly investigated by Roshd. In addition, multiple booster interaction effects have been studied, with up to three boosters in the cores; two sets of boosters were used, with different ^{235}U loadings.

The experiments described here investigate neutron spectrum effects in the boosted cores. The results are interpreted in terms of the Westcott epithermal index, r , a measure of the epithermal neutron fraction, and the effective temperature, T_n , of the thermal neutron Maxwellian distribution. Future reports will deal with measurements of reactivity and flux perturbations, and conversion ratio measurements with the lower enrichment booster.

2. FUEL AND REFERENCE LATTICE CONFIGURATIONS

2.1 Reference Lattices

All reference lattices consisted of 28-element natural UO_2 fuel assemblies shown in Figure 1 and were either air or D_2O cooled. Three lattice configurations were used.

- (1) 28.58 cm (11.25") square pitch, D_2O cooled, 52 rod, open centre.
- (2) 27.94 cm (11.00") square pitch, air-cooled, 52 rod, open centre.
- (3) 30.00 cm hexagonal pitch, D_2O cooled 55 rod, closed centre.

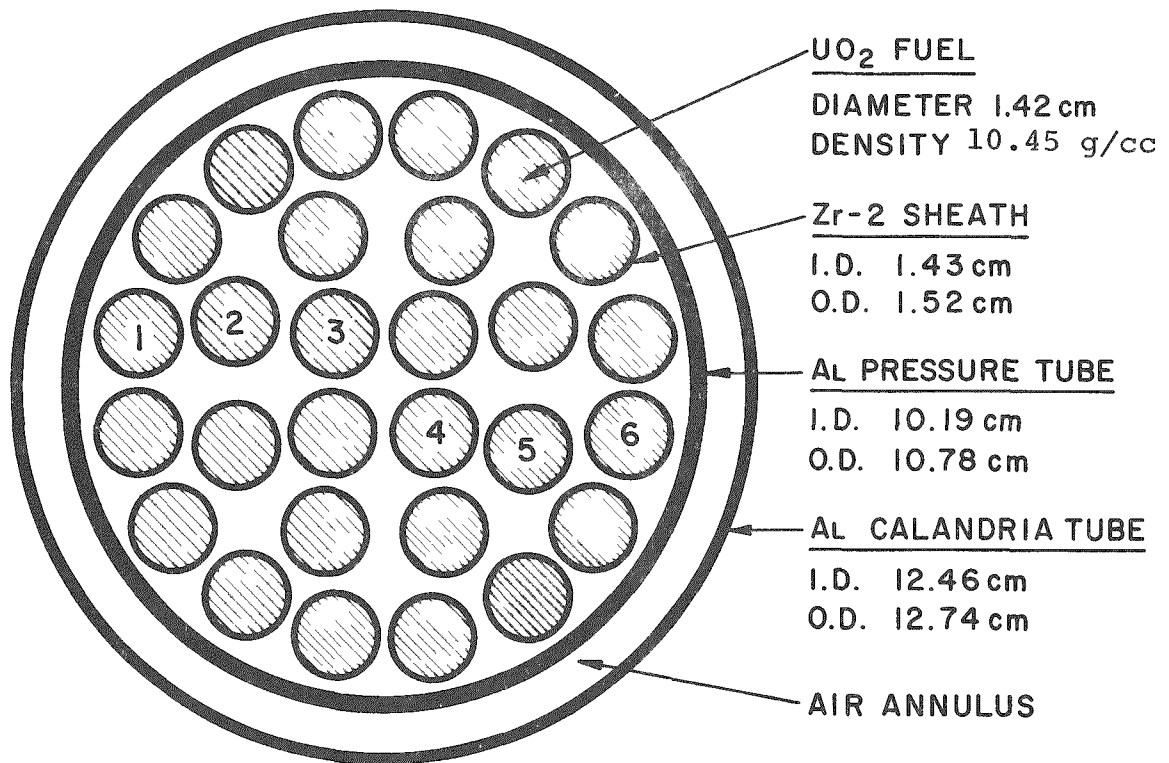

DEMOUNTABLE ELEMENTS NUMBERED 1 TO 6

Fig. 1 28-element natural UO_2 cluster

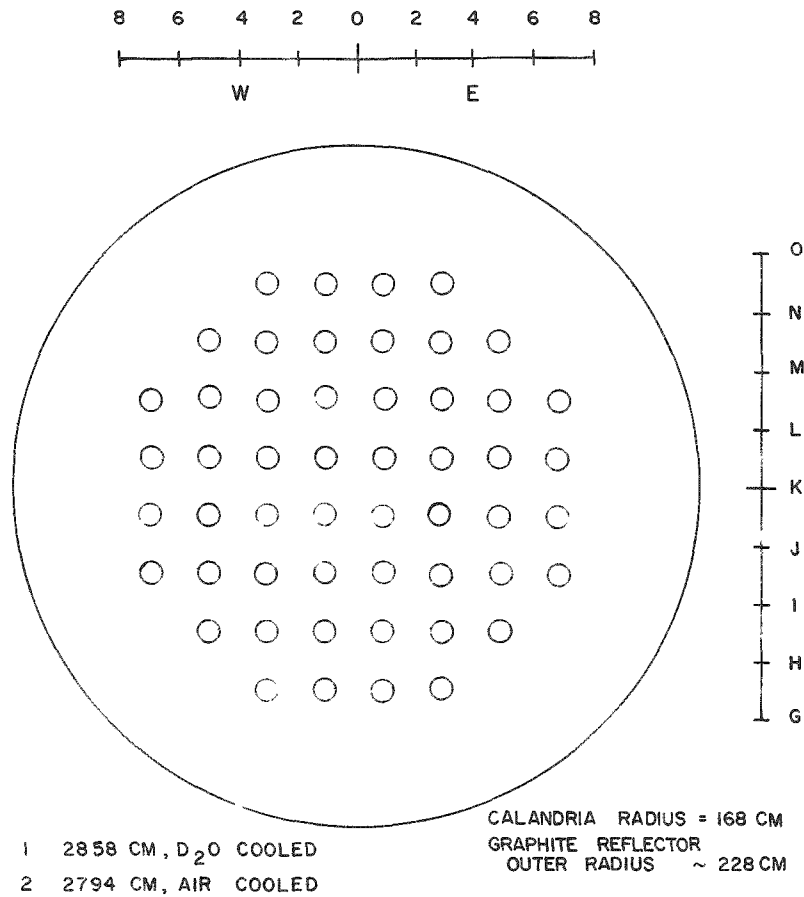

Fig. 2 52 rod square reference lattices
and co-ordinate labelling

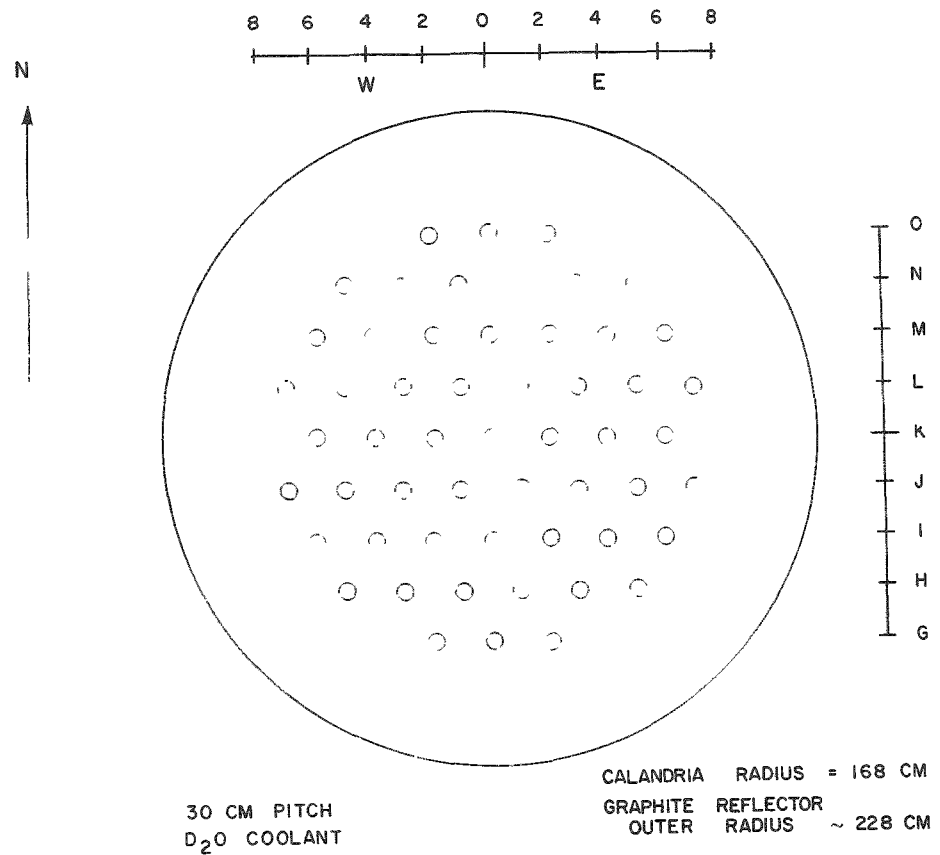

Fig. 3 55 rod hexagonal reference lattice
and co-ordinate labelling

The 30.00 cm hexagonal lattice fuel-to-moderator volume ratio approximated that of the 28.58 cm square lattice. Figures 2 and 3 show the reference lattice configurations and their respective co-ordinate labelling.

The 28-element fuel assemblies are described in detail in References 2 and 3. Each rod was composed of 5, 28-element bundles (49.67 cm in length) stacked inside a housing assembly consisting of an Al pressure tube surrounded by an Al calandria tube. One bundle was available for activation measurements inside the fuel. The end plates of this bundle were in two sections that could be easily split, thus facilitating rapid removal of the six elements that contained the detector foils (see Fig. 1).

The moderator purity and temperature varied during the experimental program, and are recorded in the tables of results.

2.2 Booster Rods and Suspension Systems

The 93.16% ^{235}U enriched (high enrichment) booster was composed of 61 fuel pencils arranged in five rings as shown in Figure 4. Each pencil measured 216.2 cm long (208.87 cm effective fuel length) and contained a core of U-Al alloy (22.5 wt% U^(a)), 0.386 cm in diameter bonded to an Al sheath (see Fig. 5). The booster loading was 4.88g ^{235}U /cm length. The clusters were assembled with two drilled end plates and four spacer plates so that individual elements could be withdrawn axially.

(a) The U-Al alloy content ratio was nominally 22.5 wt% but activation measurements interpreted by A. Okazaki⁽⁴⁾ yielded $23.1 \pm .2$ wt%.

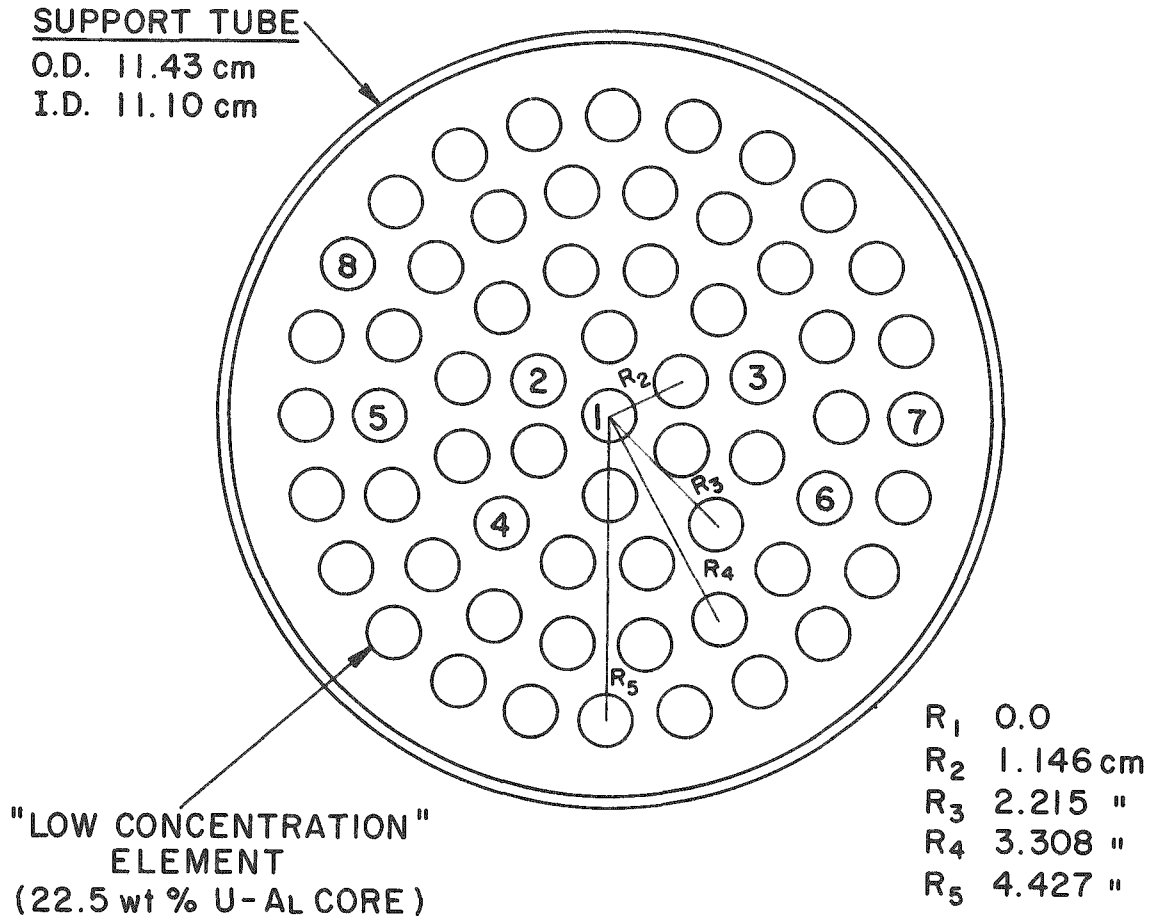

DEMOUNTABLE ELEMENTS NUMBERED 1 TO 8

Fig. 4 61-element high enrichment booster cluster

Eight elements were demountable and each was constructed so that activation detectors could be placed in a gap inside the fuel, or around the sheath, as shown in Figure 5.

The cluster was suspended in the reactor in an 11.43 cm O.D. support tube (0.165 cm wall), 231.1 cm long. The

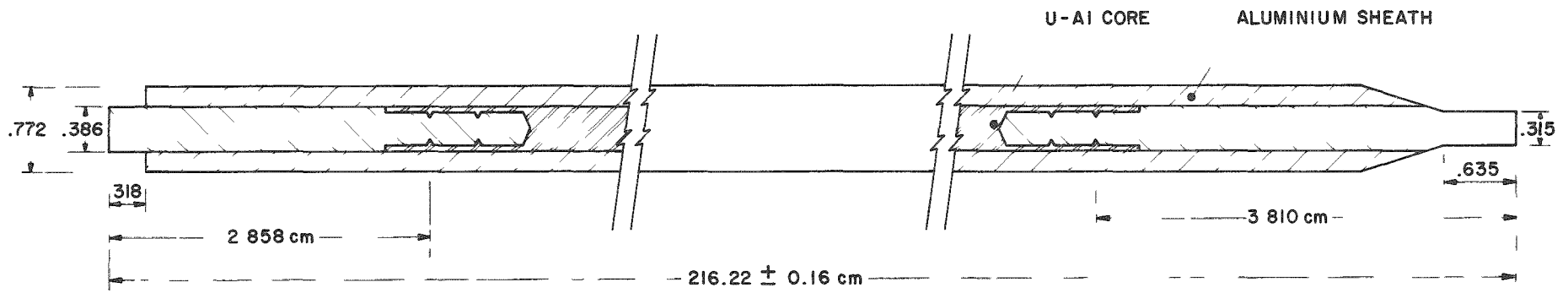

NORMAL BOOSTER ELEMENT

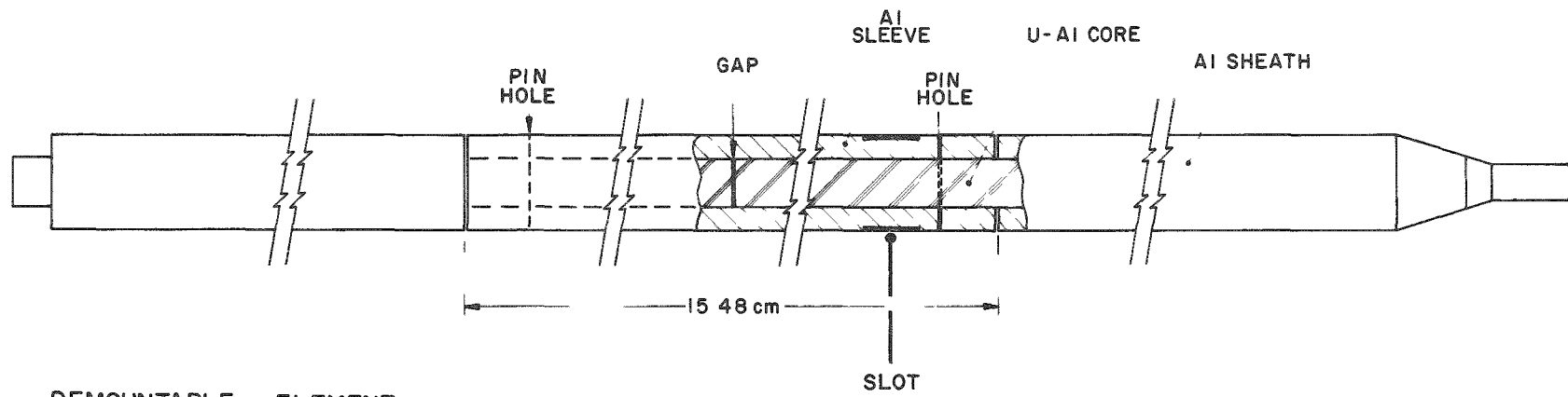

DEMOUNTABLE ELEMENT

Fig. 5 High enrichment booster fuel elements

top flange of this tube was bolted to the top of a second Al tube 166 cm long and the lower end was extended with a tube section 10.63 cm long. This booster assembly was suspended from an Al suspension bar bolted to the top of two Al clamps, which were in turn firmly attached to the two central lattice beams (see Figure 6). The bottom of the assembly was 0.3 cm from the floor of the reactor vessel to avoid any reactivity increase should the booster fall to the floor. A safety bracket was welded to the top of the booster assembly and was fitted around the two support clamps. This arrangement ensured that the booster would not tip over into the reactor if the suspension system were to fail, but allowed the assembly to hang "plumb" in the core. Slots in the support tube allowed the booster to be "cooled" by reactor D₂O moderator.

Further details of this booster are given in Reference 1.

The low enrichment booster consisted of 61 fuel pencils arranged in five rings as shown in Figure 7. Each pencil measured 188.28 cm in length (179.83 cm of fuel) and consisted of a core of U-Al alloy (24.5 wt% U^(a), density = 3.38 ± 0.05 g/cm³) 0.775 cm in diameter sheathed in Zircalloy⁽⁵⁾ (0.963 cm O.D.; 0.076 cm wall) as shown in Figure 8. The uranium was 19.91% ²³⁵U enriched and the 61-element ²³⁵U loading was 4.74 g/cm length. The pencils were assembled in a cluster with two drilled end plates and three spacer plates.

(a) The U-Al alloy concentration was nominally 24.7 wt%⁽⁵⁾ but activation measurements yielded 24.5 ± 0.05 wt%.

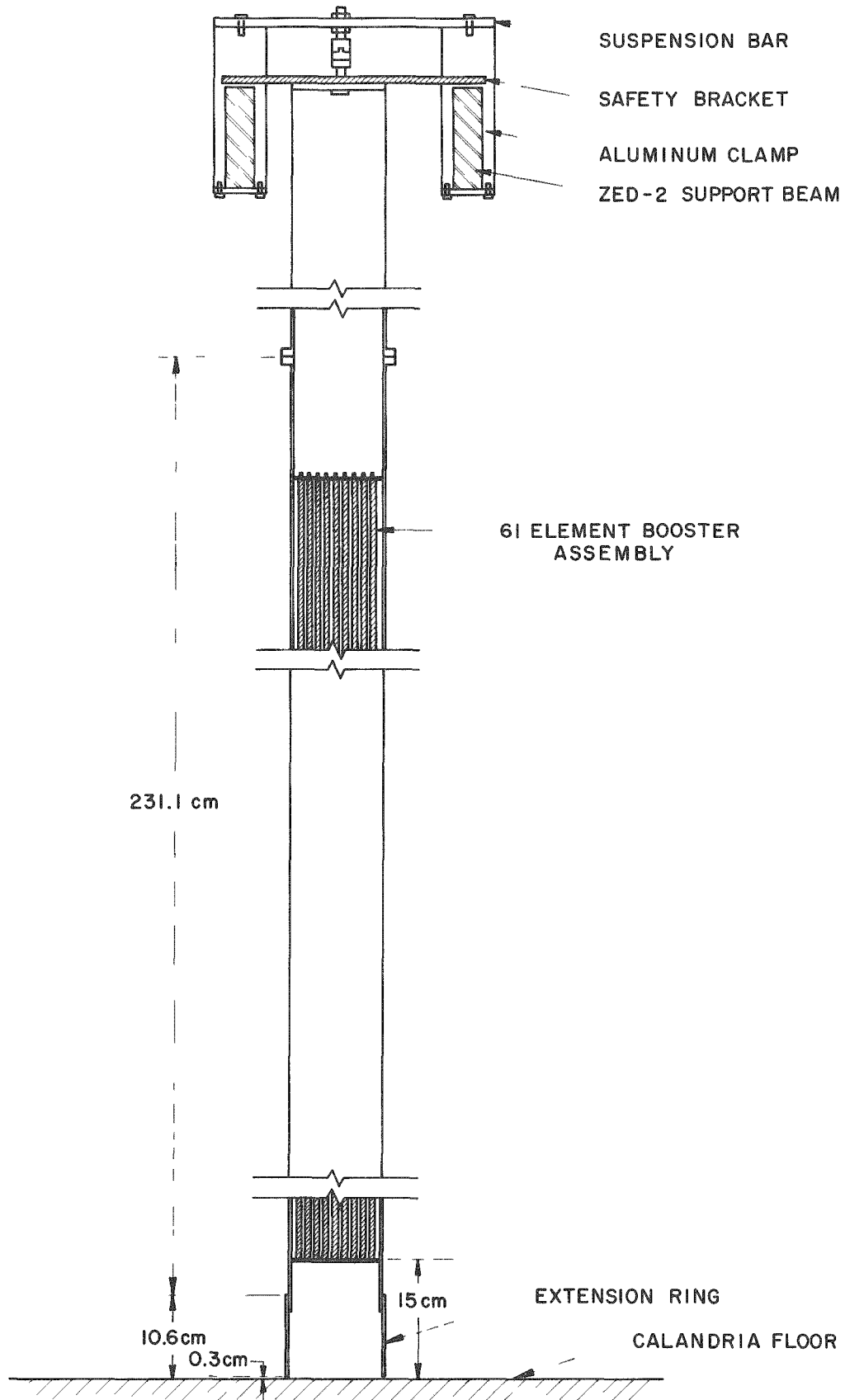

Fig. 6 High enrichment booster suspension system

SUPPORT TUBE

OD: 11.43 CM

ID: 11.10 CM

$R_1 = 0.0$ CM
 $R_2 = 1.270$ CM
 $R_3 = 2.457$ CM
 $R_4 = 3.854$ CM
 $R_5 = 4.908$ CM

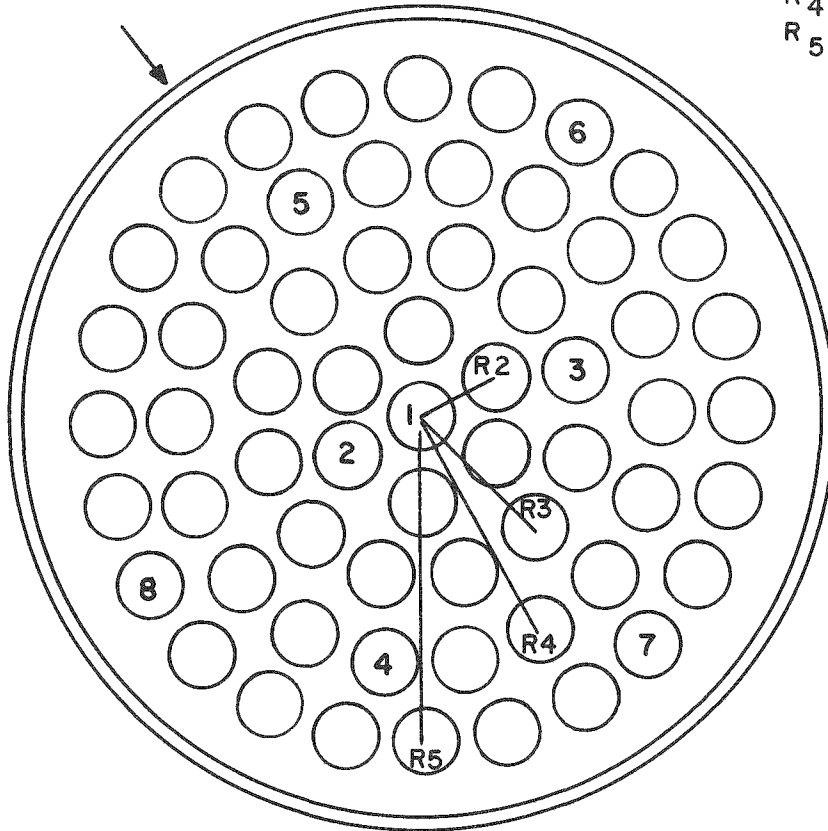

DEMOUNTABLE ELEMENTS NUMBERED 1 TO 8

Fig. 7 61-element low enrichment booster cluster

Eight elements were demountable and could be withdrawn axially. These elements consisted of U-Al alloy pellets 15.24 cm and 3.50 cm in length stacked inside the Zircaloy

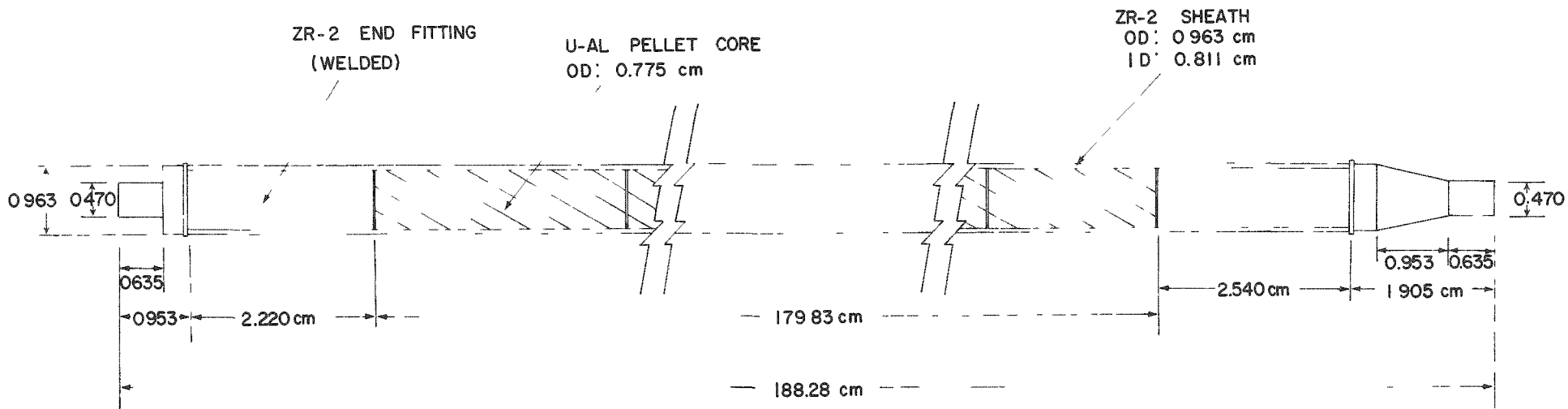

NORMAL BOOSTER FUEL ELEMENT

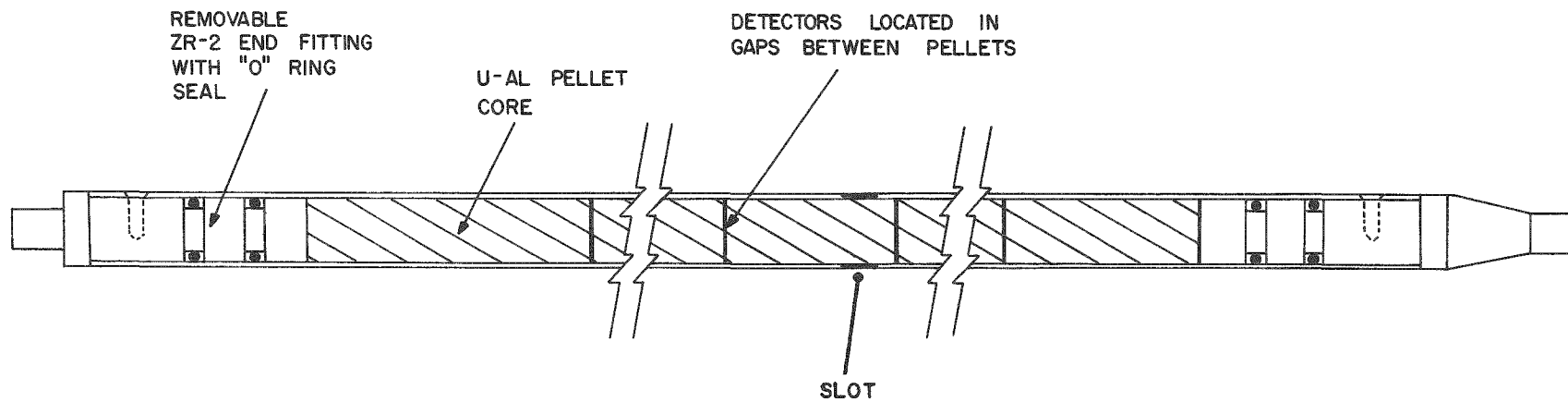

DEMOUNTABLE BOOSTER FUEL ELEMENT

Fig. 8 Low enrichment booster fuel elements

sheaths described above. The end fittings were removable for access to the fuel. As shown in Figure 8, each demountable element had grooves machined in the sheath (0.520 cm wide; 0.043 cm deep) to accommodate strip activation detectors, 49.45 cm from the base of each element (60.00 cm from the floor of the ZED-2 reactor, when the booster was suspended in the core).

The booster cluster was suspended in the reactor in an 11.43 cm O.D. Al support tube (0.165 cm wall), 231.1 cm long. The vertical suspension system was similar to that of the high enrichment booster. The horizontal suspension consisted on two Al clamps around the support tube, connected to 1.27 cm O.D., 0.089 cm wall Al tubes with Al universal joints, as shown in Figure 9. The suspension systems were secured to the beams supporting the fuel assemblies.

The 33-element boosters are shown in Figure 10. The pencils were identical, geometrically, to the high enrichment pencils, but two U-Al alloys were used: a high concentration of nominal 37.7 wt% U and a low concentration of nominal 22.5 wt% U. The pencils were arranged in four rings to form the clusters; the inner and third rings were high concentration elements. The booster loading was 3.49g $^{235}\text{U}/\text{cm}$ length. The clusters were housed in 8.89 cm O.D. (0.165 cm wall) Al support tubes and suspended in a similar manner to the 61-element boosters.

Six elements were demountable so that activation measurements could be made in the fuel pencils. They were the same as the BLW (boiling light water) demountable elements of Figure 5.

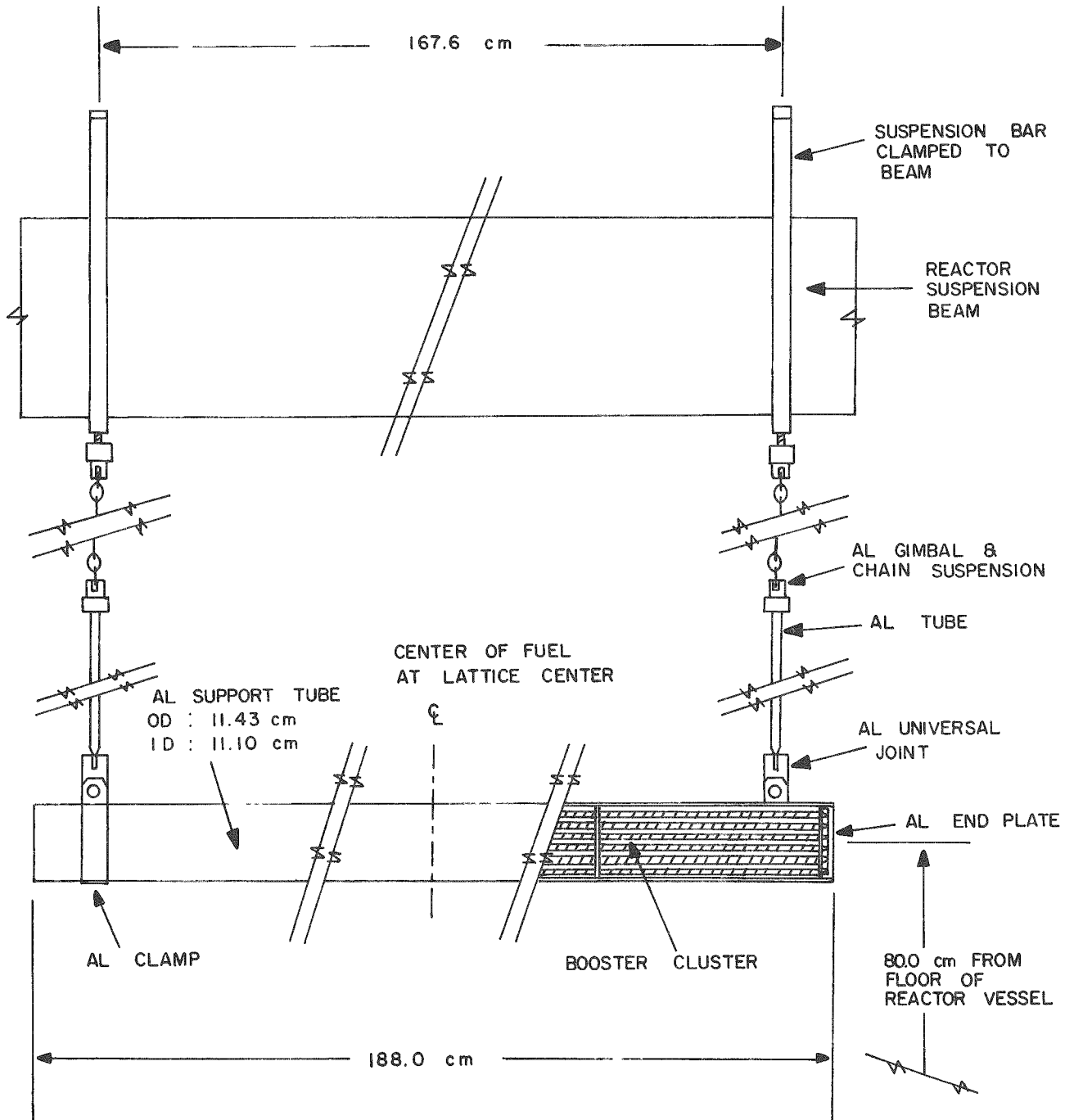
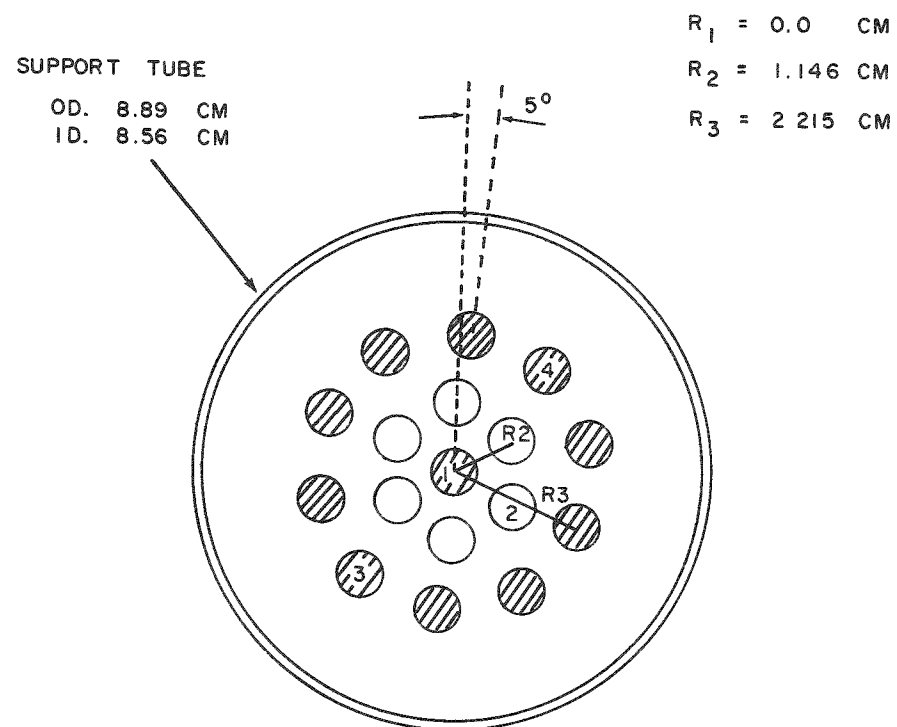
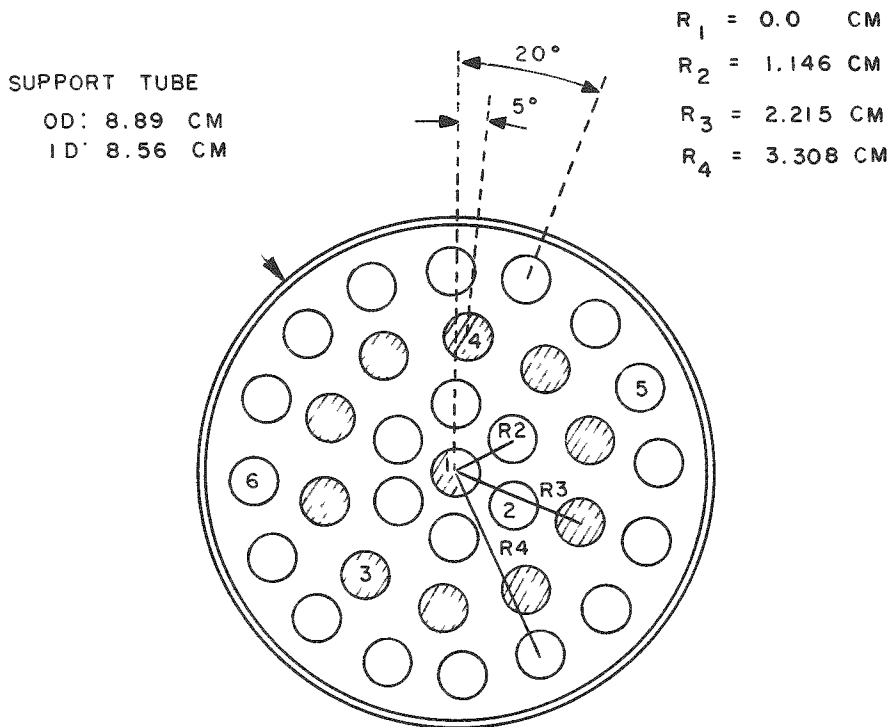

Fig. 9 61-element low enrichment booster - horizontal suspension in ZED-2



● HIGH CONC. (37.7 wt % U-Al)

○ LOW CONC. (22.5 wt % U-Al)

DEMOUNTABLE ELEMENTS NUMBERED 1 TO 6

● HIGH CONC. (37.7 wt % U-Al)

○ LOW CONC. (22.5 wt % U-Al)

DEMOUNTABLE ELEMENTS NUMBERED 1 TO 4

Fig. 10 33-element high enrichment booster cluster

Fig. 11 17-element high enrichment booster cluster

The 17-element boosters were obtained by removing the outer ring of 16 low concentration elements from the 33-element boosters as shown in Figure 11; the resulting ^{235}U loading was 2.21 g/cm length. Four elements were demountable. The suspension systems and support tubes were identical to the 33-element boosters and the horizontal suspensions were similar to that for the low enrichment 61-element booster.

3. EXPERIMENTS

3.1 General Discussion of Method

Spectral effects were interpreted using the Westcott formalism⁽⁶⁾. The parameter r , a measure of the epithermal neutron density, and T_n , the effective neutron temperature of a Maxwellian distribution of neutrons, were determined using the method described in detail by Bigham et al.⁽⁷⁾. Thin foils of Au-Al, Lu-Al and Cu were irradiated together in "packages" in the booster cells, at various locations in the core, and at a thermal reference location (thermal pit) in the D₂O moderator, outside the reactor core. At the reference site, the neutron spectrum was essentially a Maxwellian distribution with the temperature assumed equal to the physical moderator temperature.

The relative foil activity ratios are related to the neutron spectral parameters by the following expressions:

$$R_{Cu}^{Au} = \frac{(A_{Au}/A_{Cu})_x}{(A_{Au}/A_{Cu})_{th}} \quad \text{and} \quad R_{Cu}^{Lu} = \frac{(A_{Lu}/A_{Cu})_x}{(A_{Lu}/A_{Cu})_{th}}$$

where x refers to the measurement position in the lattice cell, t_h to the thermal reference locations, and where A , the foil activity is given in Westcott notation by:

$$A \propto G_t g(T_n) + G_r S_0 r \sqrt{T_n/T_0}$$

G_t and G_r are the thermal and resonance foil self shielding factors respectively. $g(T_n)$ denotes the temperature dependence of the Westcott g value for Au and Lu.

At the reference location, $r\sqrt{T_n/T_o}$ was determined from a Cd ratio measurement with thin In-Al foils. g values were taken from Westcott.⁽⁶⁾ Values of the self shielding factors were determined by S.L. Mehta⁽⁸⁾ (Appendix A): G_t was calculated using Hanna's method⁽⁹⁾ and $G_r S_o$ was determined from the Cd ratio measurement method described by Walker et al.⁽¹⁰⁾, using thin deposited Au foils as standards. The spectral parameters were obtained from the data using existing Chalk River codes, modified for Au instead of In, by S.L. Mehta.

The high radiation fields near the booster assemblies several hours after irradiation necessitated the use of Au and Cu detectors; the half-lives of In and Mn, the standard spectral detectors, were considered too short for accurate statistics during the counting of the activated detectors, due to the long waiting period before counting. Unfortunately, this meant that Westcott spectral parameters determined with Au detectors in the vicinity of ^{238}U rich fuels would be significantly lower than those measured with In. The Au activation at its major resonance (4.91 eV) would not be representative of the spectra due to the presence of the large ^{238}U resonance at 6.68 eV. Nevertheless, it was felt that the Au/Cu activation ratios could be usefully compared with cell codes such as HAMMER⁽¹¹⁾ where the spectrum is represented by a sufficiently large number of energy groups.

In addition to using Au-Al, Lu-Al and Cu detectors, Au and Cu strips were used for booster fuel pin sheath measurements, and spectral detector method normalization measurements were made with Lu-Mn-Al and In-Al alloy material.

3.2 Activation Measurements

3.2.1 Spectral Parameter Measurements

Activation measurements were made using packages of nominal 1% Au-Al alloy (0.025 cm thick), nominal 10% Lu-Al alloy (0.013 cm thick), and 0.013 cm thick Cu foils. Both 1.43 cm and 0.775 cm diameter detectors were employed. Other normalization measurements were made with 1.43 cm diameter packages of nominal 1% In-Al alloy (0.013 cm thick) and 0.025 cm thick nominal 10% Lu - 5% Mn-Al alloy foils. All foil packages were wrapped in 0.003 cm thick Al and irradiated between fuel pellets in the 28-element UO₂ reference assembly split bundle elements, between fuel pellets in the 61-element low enrichment booster elements, on booster pressure tube and reference assembly calandria tube surfaces, and at moderator sites, and at the reference location in Al thimbles. 0.5 cm wide, 0.001 cm thick Au and 0.013 cm thick Cu strips were wrapped together around the demountable booster elements in the slots machined in the sheaths, to measure the $r\sqrt{T_n/T_o}$ spectral indices at the sheath surfaces. Difficulty in accurately positioning foils within the high enriched booster elements precluded measurements of spectral parameters or fluxes in these fuel element cores.

Figure 12 shows representative foil locations in a typical ZED-2 lattice. In some experiments measurements were also made at various moderator sites near the centre of the core (booster site); detector packages were secured to a light Al framework extending from the booster and from a nearest neighbor reference fuel assembly (Figure 13).

- 28 - ELEMENT FUEL ROD
- ⊗ 61 - ELEMENT BOOSTER
- FOILS IN THIMBLES
- FOILS ON CALANDRIA TUBE
- FOILS ON AL FRAMEWORK
- × FOILS AT THERMAL REFERENCE

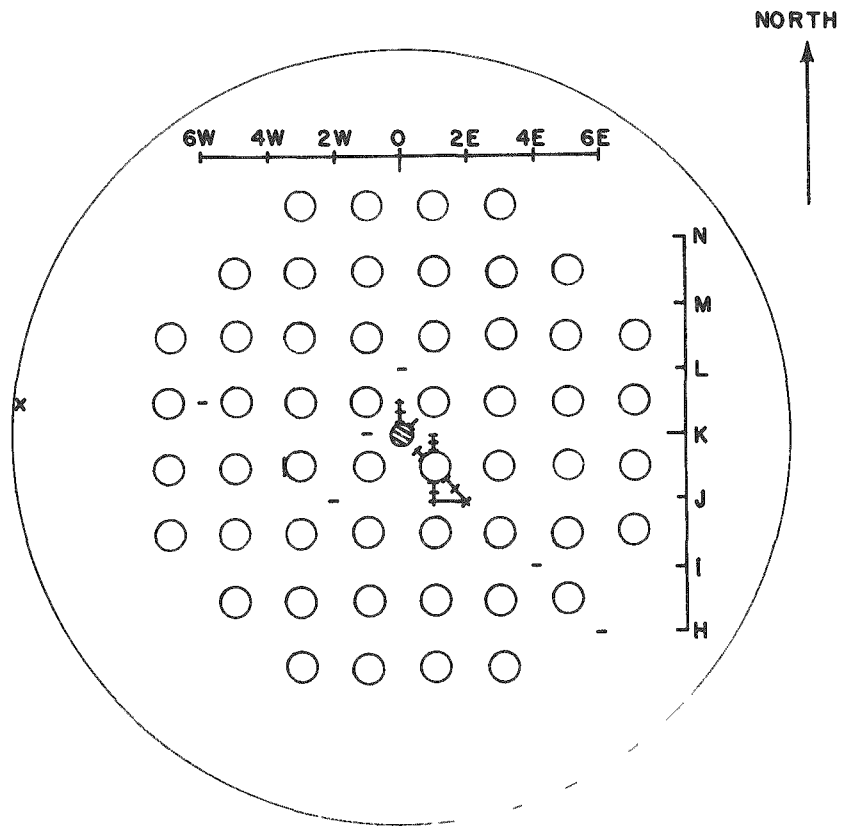
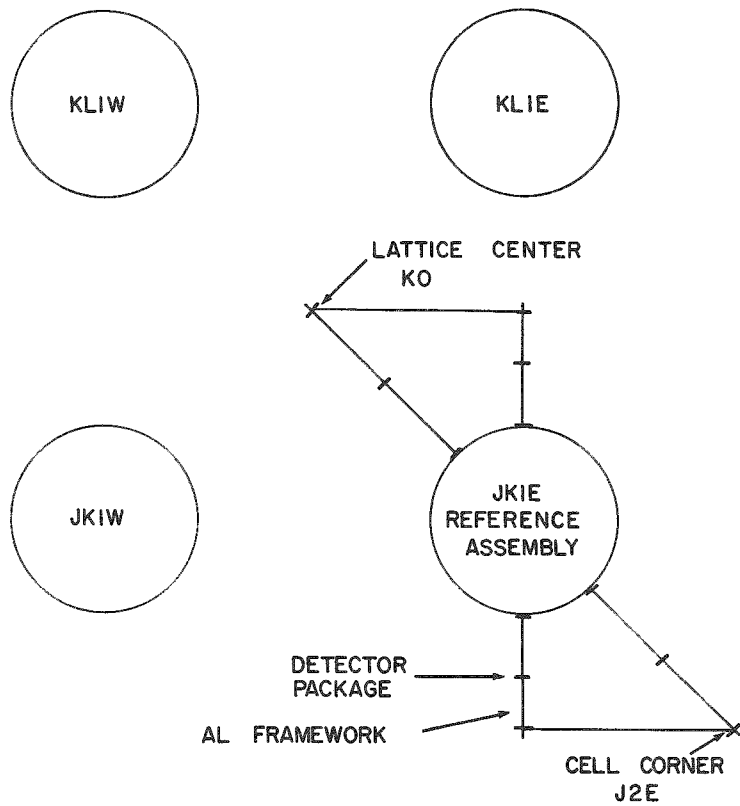
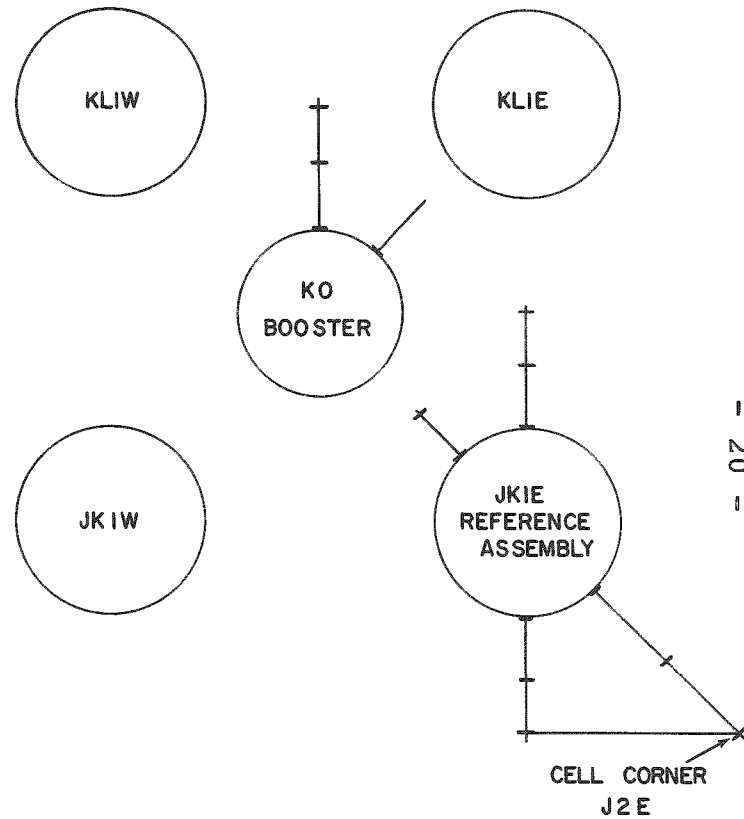

Fig. 12 Typical lattice arrangement with detectors - 28.58 cm square (D_2O) lattice and 61-element low enrichment booster²



UNPERTURBED REFERENCE LATTICE



PERTURBED BOOSTER LATTICE

Fig. 13 Spectrum detectors on Aluminum framework in moderator

In each experiment with boosters parallel to reference fuel assemblies, all detectors were at approximately the same elevation in the core, near the axial flux maximum.

At the thermal reference location (Figure 12), $r\sqrt{T_n/T_o}$ was measured with pairs of 1.13 cm diameter, 0.013 cm thick nominal 1% In-Al alloy foils, each foil in a box of Cd or Al (0.076 cm thick walls). The Cd boxes were positioned at least 20 cm above or below other detector materials, to avoid flux perturbation effects. Corrections for different axial flux values at the Cd and Al box locations were made using a set of Cu foil axial flux detectors in a nearby thimble.

3.2.2 Determination of Activities

The γ -ray activities of the irradiated foils were determined using a pair of 5.08 cm diameter (2.54 cm thick) NaI (Tl) scintillation detector systems in $\sim 4\pi$ geometry. An automatically restacking sample changer inserted "lucite" sample trays, each containing an active foil, in sequence in a small gap (< 2 cm) between the faces of two scintillators.

The output from each detector was digitalized on paper tape and computer analyzed to correct each foil for decay, counter dead-time losses, background, and isotopic content. Since the alloyed foils used were not uniform, the relative isotopic content of each detector was determined from relative activities after irradiation on a rotating wheel in the NRU thermal column.

The 12.75 h ^{64}Cu activity, 6.71 day ^{177}Lu isomeric activity, 2.70 day ^{198}Au activity and the 54 minute ^{116}In isomeric activity were determined by counting with an effective bias level of ~ 50 keV. The 2.58 h ^{56}Mn activity was determined at a bias level of ~ 500 keV to exclude all Lu activities in the Lu-Mn-Al composite foils.

The In foils were counted beginning \sim one hour after irradiation. The Mn component of the Lu-Mn-Al composite foils was counted \sim three hours after irradiation; the Lu component was counted two or three days after the irradiation to ensure that both the short lived Lu isomer activities and the Mn activity had fully decayed. The Cu and Au foils were counted one or two days following the irradiation. Reactor power, irradiation time, and length of time waited before specific foil counting were optimized to reduce counter deadtime losses associated with high count rate, but without sacrificing statistical accuracy. In each case, sufficient counts were accumulated to ensure a fractional standard error of less than 0.5%.

3.3 Experimental Configurations

A list of all experimental reactor configurations is outlined in Table 1 and case numbers are assigned for reference in the tables of results. Critical moderator levels, and moderator temperature and D_2O purity are also listed.

3.3.1 61-Element Booster Measurements

The D_2O cooled 61-element boosters were located interstitially, parallel to the reference fuel, at the center

TABLE 1
SPECTRUM MEASUREMENT EXPERIMENTS (a)

Case No.	EXPERIMENTAL CONFIGURATION (b)	Moderator		
		Critical Height (cm)	Temp. (°C)	Purity (atom % D ₂ O)
27-10	27.94 cm square (AIR) reference lattice	211.692	21.96	99.544
27-20	61-element 20% ²³⁵ U booster at K0 (in lattice 27-10)	183.858	21.71	99.544
28-10	28.58 cm square (D ₂ O) reference lattice	234.163	21.01	99.560
28-20	61-element 20% ²³⁵ U booster at K0 (in lattice 28-10)	194.148	20.95	99.554
28-30	61-element 93% ²³⁵ U booster at K0 (in lattice 28-10)	195.940	21.24	99.468
28-40	61-element 20% ²³⁵ U booster horizontal at 80.0 cm along K	192.632	21.40	99.537
28-57	3, 17-element 93% ²³⁵ U boosters horizontal: 2 at 30.5 cm along J and L and 1 at 80.0 cm along K	191.160	21.46	99.470
30-10	30.00 cm Hex (D ₂ O) reference lattice	231.321	21.46	99.536
30-24	3, 33-element 93% ²³⁵ U boosters at KL0, JK1E, JK1W (TIGHT)	159.032	21.16	99.536
30-32	3, 33-element 93% ²³⁵ U boosters at LM0, JK2E, JK2W (MED)	170.425	21.48	99.536
30-42	3, 33-element 93% ²³⁵ U boosters at MN0, IJ3E, IJ3W (LOOSE 1)	184.218	21.58	99.536
30-44	3, 33-element 93% ²³⁵ U boosters at MN0, IJ4E, IJ4W (LOOSE 2)	188.215	20.09	99.462
30-50E	Lattice 30-10 with central 19 rods voided	216.360	21.46	99.535
30-52D	Lattice 30-50E with 3, 33-element 93% ²³⁵ U boosters (MED)	166.050	21.35	99.535
30-65	3, 17-element 93% ²³⁵ U boosters at LM0, JK2E, JK2W	186.429	21.37	99.459
Detector Norm.	61-element 93% ²³⁵ U booster at K0 (in lattice 28-10)	203.974	20.95	99.341

(a) Simultaneous irradiation with fine structure detectors.

(b) All boosters D₂O cooled.

of the open center square lattices. The low enrichment booster was also located perpendicular to the fuel at an elevation of 80.0 cm along the reactor east-west diameter (K direction) in the 28.58 cm, D₂O cooled lattice (Figure 9).

In most of these experiments, both r and T_n were determined at the following representative locations throughout the core:

1. Inside booster fuel elements (Figure 7) between fuel pellets (low enrichment booster only).
2. Inside reference fuel elements (Figure 1) between fuel pellets at rod site JK1E.
3. At the surface of booster fuel elements (Figures 4 and 7).
4. At the booster pressure tube surface.
5. At the calandria tube surface of selected reference fuel assemblies.
6. At various moderator locations in the central cells of the core, on thin Al frame works (Figure 13).
7. At various moderator "cell edge" and "cell corner" locations.

The thermal reference position was located at the reactor calandria wall on the east-west reactor diameter, at least ~ 68 cm from the reactor core.

In the perpendicular booster case, measurements were also made along the length of the booster, and axial spectral measurements were made at neighboring reference fuel and moderator cell edge locations.

A spectral detector comparison experiment was done with

the high enrichment booster vertical at lattice site K0 in the 28.58 cm pitch, D₂O cooled lattice. Measurements were also made in the reference fuel elements, on the sheath of reference fuel elements and booster elements, on booster pressure tube and reference calandria tube surfaces, and at various thimble locations near the booster.

3.3.2 Measurements with Interacting Boosters

The booster interaction experiments consisted of measurements with three, 33-element, D₂O cooled, high enrichment boosters inserted interstitially (equidistant from three neighboring fuel assemblies) in a 30.00 cm hexagonal D₂O cooled reference lattice. Three booster separation configurations were studied, representing different degrees of booster coupling. The booster spacing associated with "tight" interactions was d , the reference lattice pitch (30.00 cm); the "medium" interaction separation distance was $2d$; the separation associated with "loose" interaction was $4d$. The boosters were situated symmetrically about the reactor center, as shown in Figure 14.

The boosters were inadvertently mispositioned in the loose configuration (two were at lattice sites IJ3E and IJ3W instead of IJ4E and IJ4W). This asymmetric configuration did not affect detailed measurements near the booster cell at lattice site MN0, but macroscopic effects in the core were remeasured with the boosters symmetric.

Lattice void effects with and without three 33-element D₂O cooled boosters at the medium, $2d$ separation, were investigated by voiding the central 19 reference fuel assemblies of the hexagonal reference lattice.

BOOSTER SEPARATION

30 CM

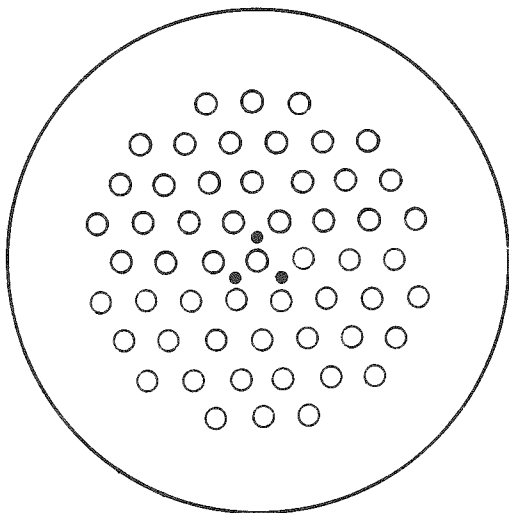

60 CM

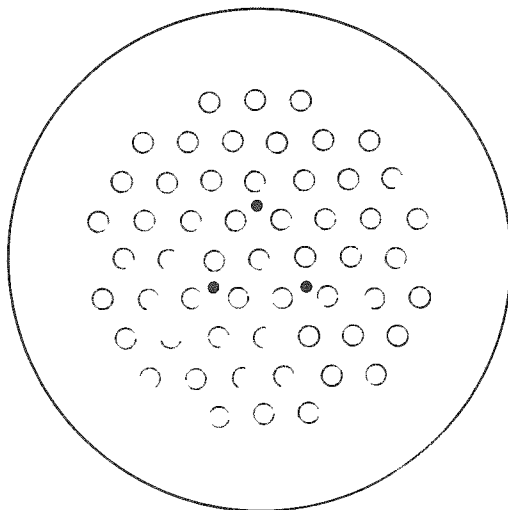

120 CM

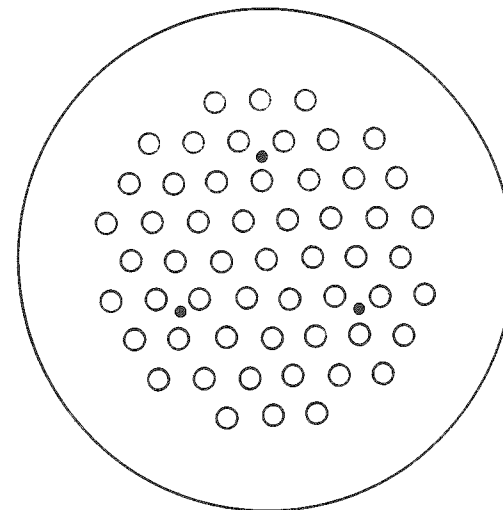

- 28 - ELEMENT, UO_2 (D_2O COOLED) REFERENCE ASSEMBLY
- 33 - ELEMENT INTERACTION BOOSTER ROD

Fig. 14 Lattice configurations with three interacting boosters parallel to reference fuel assemblies

Measurements were made with three, 17-element, D₂O cooled, high enrichment boosters at the medium (2d) separation configuration in the hexagonal lattice. Measurements were also made with these three boosters perpendicular to the fuel assemblies in the 28.58 cm square, D₂O cooled reference lattice, as shown in Figure 15. Reactor safety considerations precluded the use of the more reactive 33-element boosters. Two boosters were positioned east-west in the core, along lattice co-ordinates J and L, and were suspended 30.5 cm from the floor of the reactor calandria. The booster along the east-west diameter at lattice co-ordinate K was suspended 80.0 cm from the calandria floor. The resulting configuration was equilateral with booster separation equal to twice the lattice pitch (2d = 57.15 cm); the boosters were symmetric about the north-south diametral plane. For safety considerations, all boosters were suspended below the expected position of maximum axial importance.

The spectral parameter $r\sqrt{T_n/T_o}$ was measured at most of the various core locations described in Section 3.3.1; however, detailed booster cell moderator measurements (on the Al framework) were not done. The thermal reference position was located at the south reactor calandria wall, ~ 64 cm from the reactor core.

3.3.3 Reference Lattice Measurements

Spectral parameter measurements were made at representative locations in the three reference lattices to provide a set of reference results without the booster perturbations. Measurements were also made in the 30.00 cm pitch, hexagonal D₂O cooled reference lattice with the central 19 assemblies voided.

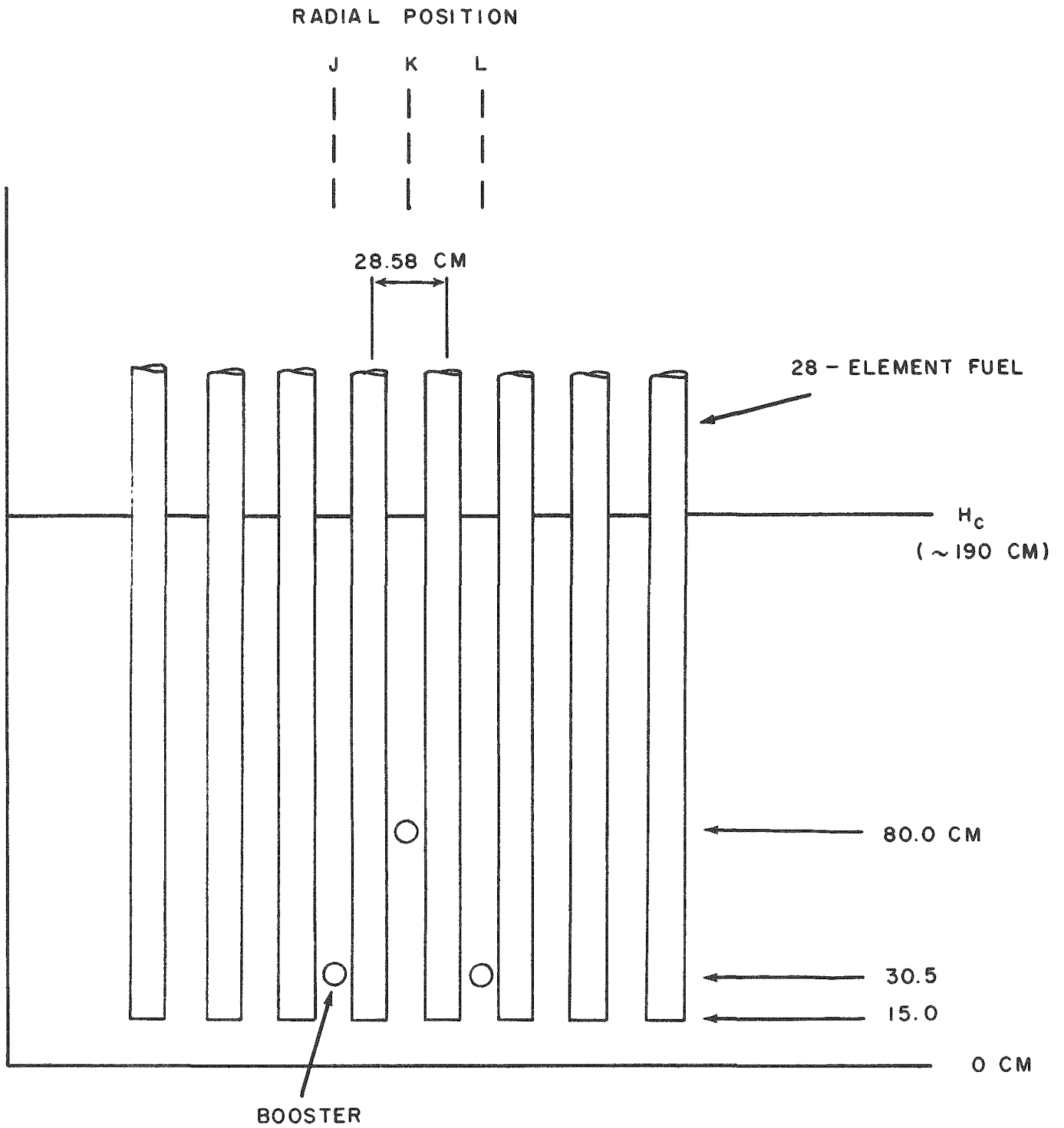

Fig. 15 3, 17-element boosters - horizontal configuration in ZED-2

4. RESULTS AND DISCUSSION

The Westcott spectral parameters $r\sqrt{T_n/T_o}$, r , and T_n were determined from detector activities as discussed in Section 3.1. The specific activity ratios, relative to the thermal reference location and the derived spectral parameters are listed in the detailed tables of results in this section and in the appendices. In most cases, the errors shown were determined by assuming a $\pm 0.5\%$ error in the determination of detector activities.

The alphameric labelling of detector locations in the core is based on the co-ordinate system shown in Figures 2 and 3.

4.1 61-Element Booster Results

4.1.1 Boosters Parallel to Reference Fuel Assemblies

Detailed spectral results in the central cells of the lattices from measurements on the Al frameworks, on booster and reference assembly pressure tube and calandria tube surfaces, and in thimbles are listed in Tables 2 to 6. The results in a direction south-east from the lattice centers are shown in Figures 16 to 20. Also shown are booster fuel pin sheath surface averages and reference fuel average values. Macroscopic spectral results are tabulated in Appendix B. Booster fuel pin mean, sheath surface mean, reference fuel pin mean, and spectral results at representative lattice sites are listed in Table 7 to facilitate direct comparison between the experimental configurations.

With the exception of Case 28-10, measurements in the 28-element reference fuel pins were made with Au detectors.

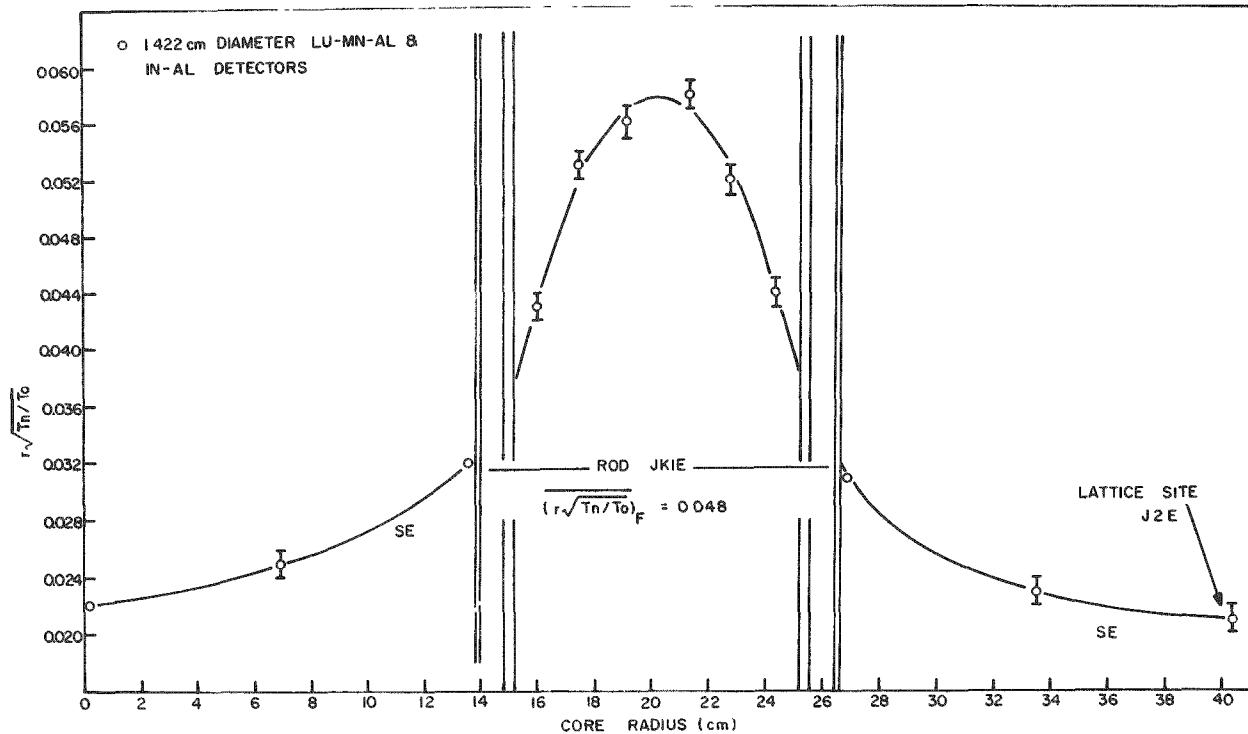

Fig. 16 $r\sqrt{T_n/T_o}$ SE of lattice center: Case 28-10

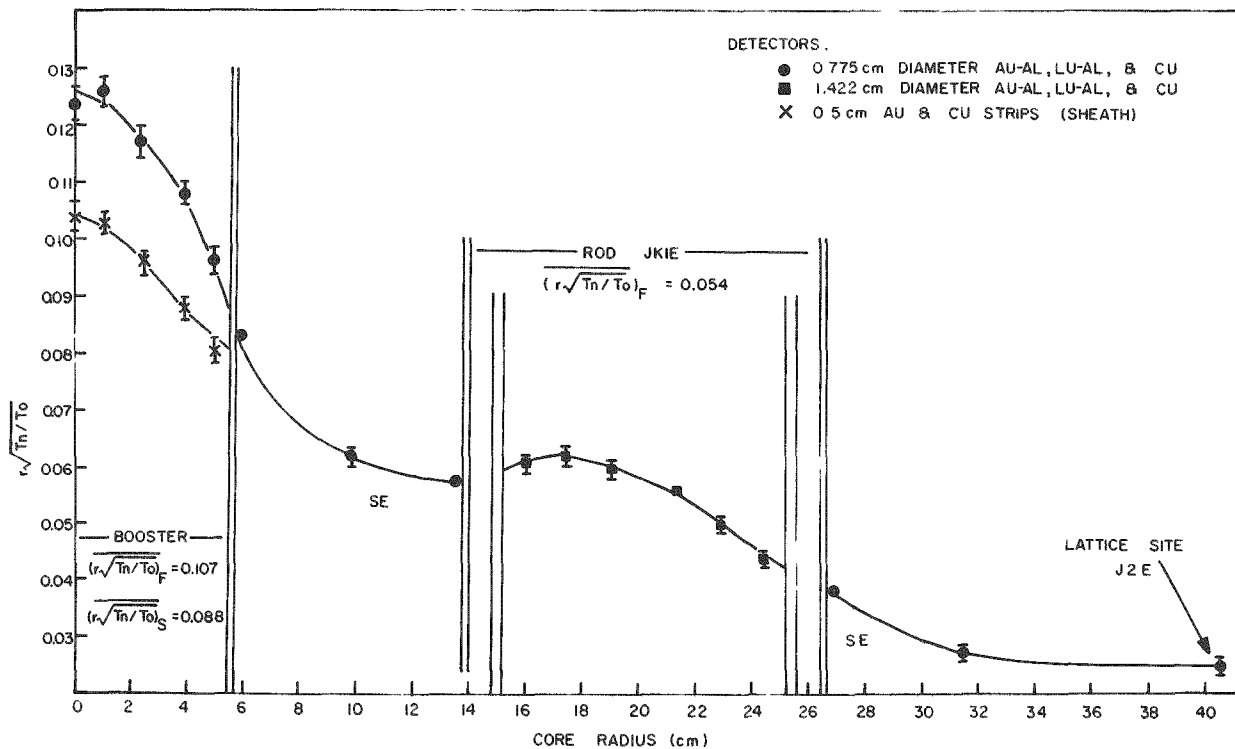

Fig. 17 $r\sqrt{T_n/T_o}$ SE of lattice center; Case 28-20

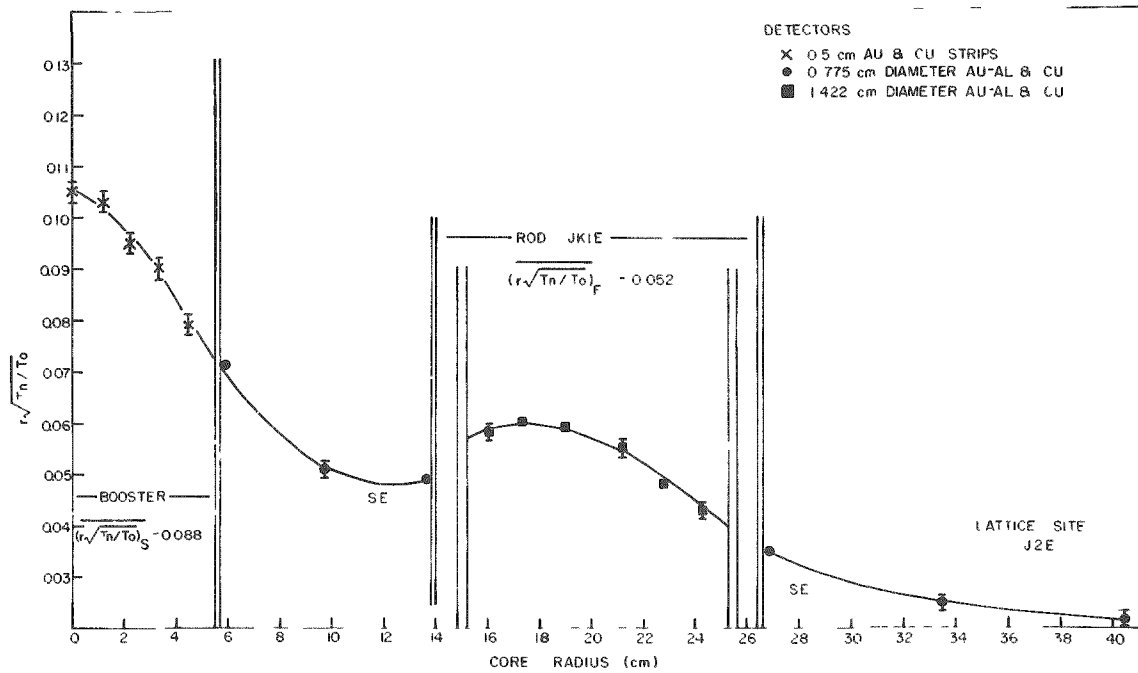

Fig. 18 $r\sqrt{T_n/T_o}$ SE of lattice center: Case 28-30

TABLE 2
MEASURED NEUTRON FLUX AND RATIOS IN A LATTICE CELL
CASE 28-10 28.59 cm (H_2O) effective lattice

Detector Location (a)	Measurement Position (cm)	Position Measured From	Direction	In/Mn (b) Act. Ratio	$r\sqrt{T_n/T_o}$ (c)	L/Mn (d) Act. Ratio	r	Tn (°C)	Method
Mod.	0.021	Lattice Center	Nw	1.339 ± .014	0.022 ± .001	1.046 ± .010	0.021	32 ± 3	(d)
Cal. S.	6.84	Lattice Center	SE	1.410 ± .014	0.025 ± .001	1.052 ± .011	0.024	34 ± 3	
Fuel (e)	13.84			1.526 ± .015	0.032 ± .001	1.078 ± .011	0.031	41 ± 3	
	16.00			1.705 ± .017	0.043 ± .001	1.180 ± .012	0.039	71 ± 4	
	17.56			1.875 ± .019	0.053 ± .001	1.273 ± .013	0.047	101 ± 5	
	19.05			1.922 ± .019	0.056 ± .001	1.264 ± .013	0.050	99 ± 5	
	21.37			1.949 ± .019	0.058 ± .001	1.280 ± .013	0.051	105 ± 5	
	22.86			1.855 ± .019	0.052 ± .001	1.250 ± .013	0.048	93 ± 5	
	24.42			1.728 ± .017	0.044 ± .001	1.189 ± .012	0.040	74 ± 4	
Cal. S.	26.58			1.511 ± .014	0.031 ± .001	1.083 ± .011	0.030	43 ± 3	
Mod.	33.53			1.384 ± .014	0.023 ± .001	1.029 ± .010	0.023	28 ± 3	
	40.48			1.376 ± .014	0.021 ± .001	1.029 ± .010	0.021	28 ± 3	
Mod.	9.99	Lattice Center	E	1.403 ± .014	0.024 ± .001	1.023 ± .010	0.024	26 ± 3	
Cal. S.	6.37	Center of Rod JKIE	N	1.572 ± .001	0.032 ± .001	1.090 ± .011	0.031	45 ± 3	
Mod.	10.52			1.436 ± .011	0.026 ± .001	1.047 ± .010	0.026	32 ± 3	
	14.47			1.427 ± .014	0.026 ± .001	1.045 ± .010	0.025	32 ± 3	
Cal. S.	6.37	Center of Rod JKIE	S	1.536 ± .015	0.032 ± .001	1.032 ± .011	0.031	45 ± 4	
Mod.	10.57			1.424 ± .014	0.026 ± .001	1.027 ± .010	0.025	27 ± 3	
	14.29			1.419 ± .014	0.025 ± .001	1.038 ± .010	0.025	30 ± 3	
Thermal Pit				1.000	0.181 ± 10 ⁻³	1.000		21.701	

(a) Mod., Cal. S., and Fuel refer to detector locations in the moderator, on a calandria tube surface, and in the fuel pin, respectively.
 (b) In/Mn or L/Mn ratios are ratios at the measurement position, relative to the same ratio at the thermal pit location. The $r\sqrt{T_n/T_o}$ value reported at the thermal pit is determined from a Cd ratio method with In foils.
 (c) $10 - 10D_2O - 21.01°C$.
 (d) 1.422 cm diameter Li-Mn-Al and Ir-Al foil packages.
 (e) Measurement position quoted for fuel are distances measured from the lattice center, SE to the appropriate fuel ring radius.

TABLE 3

MEASURED NEUTRON SPECTRUM PARAMETERS IN A PERTURBED LATTICE CELL

CASL 28-20: 28.58 cm (D₂O) Reference Lattice
61-element 20% ²³⁵U Booster at K0

Detector Location (a)	Measurement Position (cm)	Position Measured From	Equivalent Direction (b)	Au/Cu (e) Act. Ratio	$r\sqrt{T_N/T_0}$ (d)	Lu/Cu (c) Act. Ratio	r	T _N (°C)	Method		
Booster F. (e)	0.00	Lattice Center	SE	2.839 ± .038	0.124 ± .003	1.260 ± .017	0.108	115 ± 11	(f)		
	1.27			2.866 ± .038	0.126 ± .003	1.280 ± .017	0.108	124 ± 12			
	2.46			2.740 ± .036	0.117 ± .003	1.259 ± .017	0.102	112 ± 10			
	3.85			2.603 ± .034	0.107 ± .002	1.240 ± .016	0.095	102 ± 9			
	3.85			2.620 ± .035	0.108 ± .002	1.248 ± .017	0.095	106 ± 10			
	4.91			2.421 ± .032	0.094 ± .002	1.220 ± .016	0.085	92 ± 8			
	4.91			2.446 ± .032	0.096 ± .002	1.200 ± .016	0.087	85 ± 8			
	4.91			2.460 ± .033	0.097 ± .002	1.204 ± .016	0.087	87 ± 8			
	0.00			1.790 ± .018	0.104 ± .002						(g)
	1.27			1.778 ± .018	0.103 ± .002						
2.46	1.731 ± .017	0.096 ± .002									
3.85	1.656 ± .017	0.086 ± .002									
3.85	1.687 ± .017	0.090 ± .002									
4.91	1.659 ± .016	0.084 ± .002									
4.91	1.591 ± .016	0.078 ± .002									
4.91	1.601 ± .016	0.079 ± .002									
5.72	2.260 ± .030	0.083 ± .002	1.158 ± .015	0.077	68 ± 7	(f)					
9.78	1.943 ± .026	0.062 ± .002	1.104 ± .015	0.059	49 ± 5						
13.84	1.883 ± .025	0.058 ± .002	1.143 ± .015	0.054	60 ± 6						
16.00	1.939 ± .019	0.061 ± .001	1.228 ± .012	0.055	87 ± 5						
17.56	1.946 ± .019	0.062 ± .001	1.272 ± .013	0.055	101 ± 5						
19.05	1.916 ± .019	0.060 ± .001	1.312 ± .013	0.052	112 ± 5						
21.37	1.864 ± .019	0.056 ± .001	1.304 ± .013	0.049	109 ± 5						
22.86	1.774 ± .018	0.050 ± .001	1.264 ± .013	0.045	95 ± 5						
24.42	1.685 ± .017	0.044 ± .001	1.217 ± .012	0.040	81 ± 4						
26.58	1.604 ± .021	0.039 ± .001	1.124 ± .015	0.037	54 ± 5						
33.53	1.426 ± .019	0.028 ± .001	1.059 ± .014	0.027	35 ± 4	(f)					
40.47	1.383 ± .018	0.025 ± .001	1.069 ± .014	0.024	38 ± 4						
5.72	2.221 ± .029	0.081 ± .002	1.152 ± .015	0.075	66 ± 7						
9.97	1.870 ± .025	0.057 ± .002	1.101 ± .015	0.054	47 ± 5						
14.32	1.711 ± .023	0.046 ± .001	1.087 ± .014	0.045	43 ± 5						
6.37	1.792 ± .024	0.052 ± .002	1.135 ± .015	0.049	58 ± 5						
10.37	1.687 ± .022	0.045 ± .001	1.077 ± .014	0.043	40 ± 5						
14.29	1.686 ± .022	0.045 ± .001	1.092 ± .014	0.043	44 ± 5						
6.37	1.604 ± .021	0.039 ± .001	1.117 ± .015	0.037	52 ± 5						
10.57	1.496 ± .020	0.032 ± .001	1.067 ± .014	0.031	37 ± 4						
14.29	1.454 ± .019	0.030 ± .001	1.054 ± .014	0.029	34 ± 4						
Thermal Pit			1.000	0.450×10^{-3}	1.000		20.95				

- (a) Booster F., Booster S., Booster P.T., Mod., Cal. S., and Fuel refer to detector locations in the booster fuel pins, on booster fuel pin sheaths, on the booster pressure tube, in the moderator, on a reference assembly calandria surface, and in the reference assembly fuel pins, respectively.
- (b) Reported spectrum parameters in direction E and SE from the lattice center were obtained in part from measurements in equivalent directions N and NE.
- (c) Au/Cu or Lu/Cu ratios are ratios at the measurement position, relative to the same ratio at the thermal pit location. The $r\sqrt{T_N/T_0}$ value reported at the thermal pit was determined from a Cd ratio method with In foils.
- (d) $T_0 = T_{D_2O} = 20.95^\circ\text{C}$.
- (e) Measurement positions reported are distances measured from the lattice center, SE to the appropriate booster or fuel ring radii.
- (f) 0.775 cm diameter Au-Al, Lu-Al, and Cu foil packages.
- (g) 0.5 cm wide Au and Cu strips wrapped around sheath.
- (h) 1.422 cm diameter Au-Al, Lu-Al and Cu foil packages.

TABLE 1

MFA-BURLI NEUTRON SPECTRUM PARAMETERS IN A PERTURBED LATTICE CELL
CASE 28-30: 28.58 cm (D₂O) Reference Lattice
61-clement 9j_e ²³⁵U Booster at K0

Detector Location (a)	Measurement Position (cm)	Position Measured From	Equivalent Direction (b)	In, Mn or Au/Cu Act. Ratio (c)	$r\sqrt{T_n/T_0}$ (d)	Lu/Mn or Lu/Cu Act. Ratio (e)	r	T_n (°C)	Method			
Booster S. (e)	0.00	Lattice Center	SE	1.793 ± .018	0.105 ± .002				(f)			
	1.15			1.781 ± .018	0.103 ± .002							
	2.22			1.723 ± .017	0.095 ± .002							
	3.31			1.690 ± .017	0.091 ± .002							
	3.31			1.679 ± .017	0.089 ± .002							
	4.43			1.591 ± .016	0.078 ± .002							
	4.43			1.607 ± .016	0.080 ± .002							
	5.72			2.071 ± .027	0.071 ± .002							
	9.78			1.783 ± .024	0.251 ± .002							
	13.84			1.753 ± .023	0.049 ± .002							
Booster P.T. Mod. Cal. S. Fuel (e)	16.00	Lattice Center	L	1.886 ± .019	0.058 ± .001				(g)			
	17.56			1.911 ± .019	0.060 ± .001							
	19.05			1.886 ± .019	0.058 ± .001							
	19.05			1.902 ± .019	0.059 ± .001	1.280 ± .013	0.052	103 ± 5				
	19.05			2.269 ± .023	0.079 ± .002	1.300 ± .013	0.068	117 ± 6				
	21.37			1.835 ± .018	0.055 ± .001							
	21.37			1.822 ± .018	0.054 ± .001	1.293 ± .013	0.047	105 ± 5				
	21.37			2.181 ± .022	0.073 ± .002	1.289 ± .013	0.064	112 ± 6				
	22.86			1.739 ± .017	0.048 ± .001							
	24.42			1.655 ± .017	0.043 ± .001							
Cal. S. Mod.	26.58	Lattice Center	L	1.538 ± .020	0.035 ± .001				(g)			
	33.53			1.375 ± .018	0.025 ± .001							
Booster P.L. Mod. Cal. S.	40.47	Center of rod JKII	N	1.338 ± .018	0.022 ± .001				(h)			
	5.72			2.060 ± .027	0.070 ± .002							
	5.72			2.106 ± .021	0.073 ± .001	1.132 ± .011	0.009	58 ± 5				
	5.72			2.059 ± .021	0.065 ± .001	1.131 ± .011	0.061	60 ± 5				
	9.77			1.767 ± .023	0.050 ± .002							
	14.32			1.611 ± .021	0.040 ± .001							
	6.37			1.698 ± .022	0.046 ± .001							
	6.37			1.739 ± .017	0.048 ± .001	1.140 ± .011	0.045	59 ± 4				
	6.37			1.797 ± .018	0.049 ± .001	1.133 ± .011	0.046	58 ± 4				
	10.37			1.599 ± .021	0.039 ± .001							
Mod. Cal. S. Mod.	14.29	Center of rod JKII	S	1.613 ± .021	0.040 ± .001				(i)			
	14.29			1.645 ± .016	0.042 ± .001							
	14.29			1.647 ± .017	0.040 ± .001	1.070 ± .011	0.038	39 ± 4				
	14.29			1.552 ± .021	0.036 ± .001							
	6.37			1.435 ± .019	0.029 ± .001							
	10.57			1.405 ± .019	0.027 ± .001							
	14.29			1.405 ± .019	0.027 ± .001							
	Thermal Fit					1.000	0.127 × 10 ⁻³	1.000			21.24	

- (a) Booster S., Booster P.T., Mod, Cal. S., and Fuel refer to detector locations on booster fuel pin sheaths, on the booster pressure tube, in the moderator, or a reference assembly calandria surface, and in the reference assembly fuel pins, respectively.
- (b) Reported spectrum parameters in directions E and SE from the lattice center were obtained in part from measurements in equivalent direction N and NE.
- (c) Reported activity ratios at a measurement position were determined relative to the appropriate ratios at the thermal pit. The $r\sqrt{T_n/T_0}$ value reported at the thermal pit was determined from a Cd ratio method with In foils.
- (d) $T_0 - T_{D_2O} = 21.24$ °C.
- (e) Measurement positions reported are distances measured from the lattice center, SE to the appropriate booster or fuel ring radii.
- (f) 0.5 cm wide Au and Cu strips wrapped around sheath.
- (g) 0.775 cm diameter Au-Al and Cu foil packages.
- (h) 1.422 cm diameter Au-Al and Cu foil packages.
- (i) 1.422 cm diameter Au-Al, Lu-Al and Cu foil package.
- (j) 1.422 cm diameter Lu-Mn-Al and In-Al foil package.

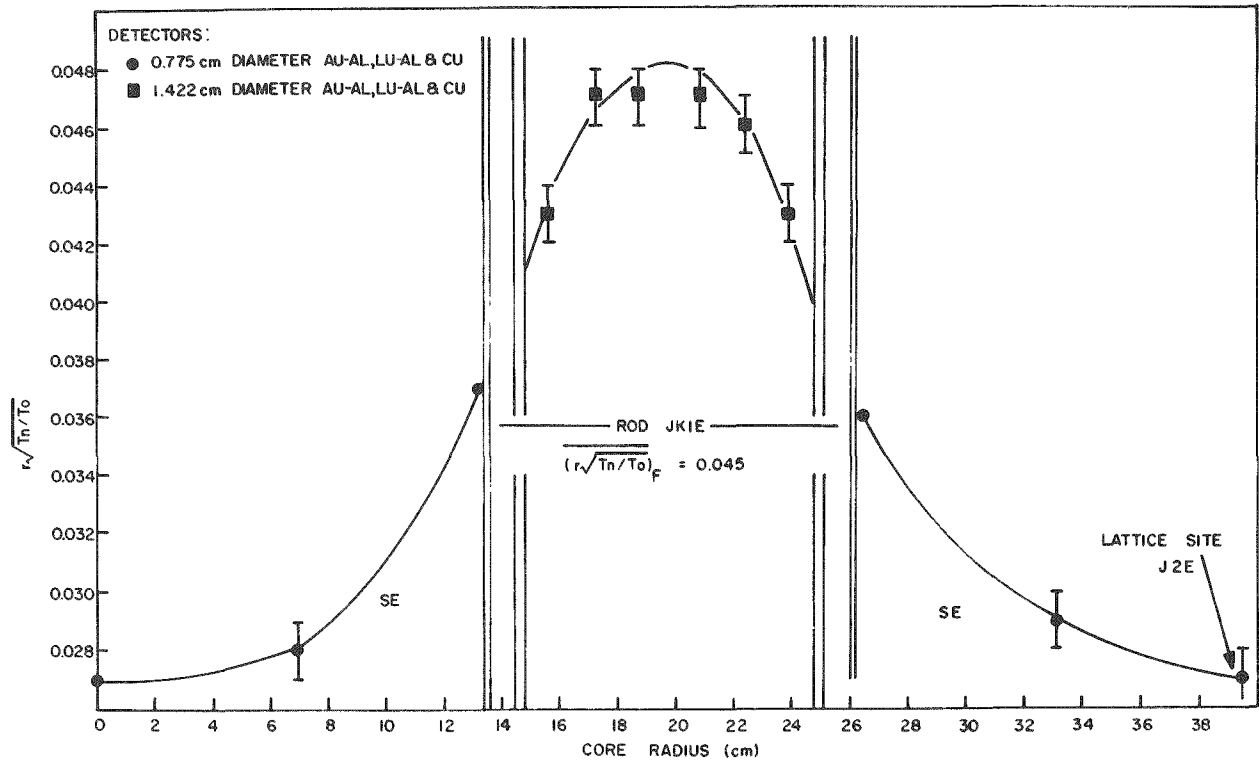

Fig. 19 $r\sqrt{T_n/T_o}$ SE of lattice center: Case 27-10

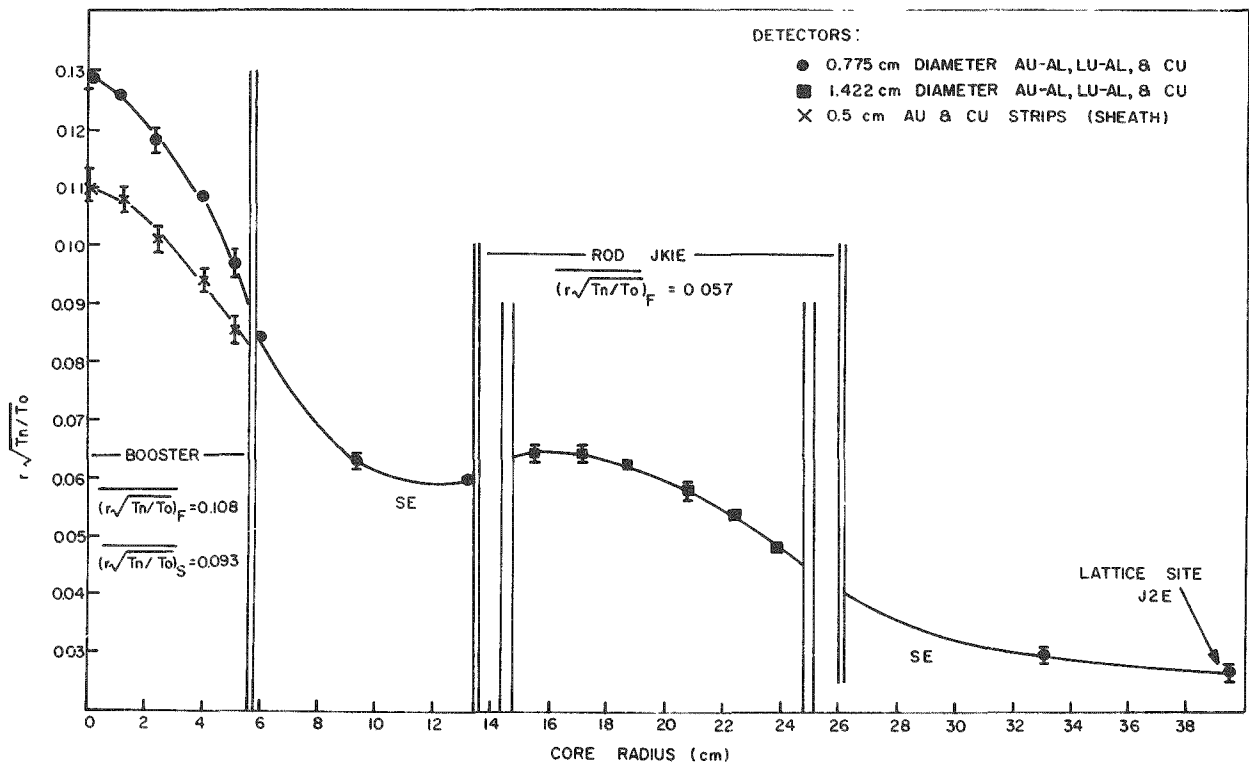

Fig. 20 $r\sqrt{T_n/T_o}$ SE of lattice center: Case 27-20

TABLL 5

MEASURED NEUTRON SPECTRUM PARAMETERS IN A LATTICE CELL

CASE 27-10: 27.94 cm (AIR) Reference Lattice

Detector (a) Location	Measurement Position (cm)	Position Measured From	Direction	Au/Cu (b) Act. Ratio	$r \frac{T_n}{T_0}$ (c)	Lu/Cu (b) Act. Ratio	r	T_n (°C)	Method
Mod.	0.01	Lattice Center	SE	1.407 ± .014	0.027 ± .001	1.060 ± .011	0.026	36 ± 3	(e)
	6.44			1.429 ± .014	0.028 ± .001	1.062 ± .011	0.027	37 ± 3	
Cal. S.	13.39			1.569 ± .016	0.037 ± .001	1.146 ± .011	0.035	61 ± 4	
Fuel (a)	15.55			1.656 ± .017	0.043 ± .001	1.218 ± .012	0.039	82 ± 4	(f)
	17.11			1.724 ± .017	0.047 ± .001	1.291 ± .029	0.042	104 ± 5	
	18.59			1.724 ± .017	0.047 ± .001	1.366 ± .013	0.041	108 ± 5	
	20.92			1.717 ± .017	0.047 ± .001	1.297 ± .013	0.041	106 ± 5	
	22.41			1.708 ± .017	0.046 ± .001	1.268 ± .013	0.041	97 ± 5	
	23.96			1.663 ± .017	0.043 ± .001	1.213 ± .021	0.039	81 ± 4	
Cal. S. Mod.	26.13			1.553 ± .016	0.036 ± .001	1.141 ± .011	0.034	60 ± 4	(e)
	33.08	1.436 ± .014	0.029 ± .001	1.060 ± .011	0.028	37 ± 3			
	39.47	1.405 ± .014	0.027 ± .001	1.052 ± .011	0.026	37 ± 3			
Cal. S. Mod.	6.37	Center of rod JK1E	N	1.579 ± .016	0.038 ± .001	1.141 ± .011	0.035	60 ± 4	
	10.52			1.484 ± .015	0.036 ± .001	1.078 ± .011	0.031	42 ± 3	
	13.92			1.463 ± .015	0.030 ± .001	1.065 ± .011	0.029	38 ± 3	
Cal. S. Mod.	6.37	Center of rod JK1E	S	1.579 ± .016	0.038 ± .001	1.140 ± .011	0.035	59 ± 4	
	10.57			1.477 ± .015	0.031 ± .001	1.075 ± .011	0.030	41 ± 3	
	13.97			1.452 ± .015	0.030 ± .001	1.068 ± .011	0.029	39 ± 3	
Thermal Pit				1.000	0.135×10^{-3}	1.000		21.96	

- (a) Mod., Cal. S., and Fuel refer to detector locations in the moderator, on a Calandria tube surface, and in the fuel pins respectively.
- (b) Au/Cu or Lu/Cu ratios are ratios at the measurement position, relative to the same ratio at the thermal pit location. The $r \frac{T_n}{T_0}$ value reported at the thermal pit was determined from a Cd ratio method with In foils.
- (c) $T_0 = T_{D_2O} = 21.96$
- (d) Measurement distances quoted for fuel are distances measured from the lattice center, SE to the appropriate fuel ring radii.
- (e) 0.775 cm diameter Au-Al, Lu-Al and Cu foil packages.
- (f) 1.422 cm diameter Au-Al, Lu-Al and Cu foil packages.

TABLE 6
MEASURED NEUTRON SPECTRUM PARAMETERS IN A PERTURBED LATTICE CELL

CASE 27-20: 27.94 cm (AIR) Reference Lattice
61-element 20% ²³⁵U Booster at K0

Detector (a) Location	Measurement Position (cm)	Position Measured From	(b) Equivalent Direction	Au/Cu (c) Act. Ratio	$r\sqrt{T_n/T_0}$ (d)	Lu/Cu (c) Act. Ratio	r	T _n (°C)	Method	
Booster F. (e)	0.00	Lattice Center	SE	2.909 ± .029	0.129 ± .002	1.281 ± .017	0.111	127 ± 12	(g)	
	1.27			2.864 ± .029	0.126 ± .002	1.279 ± .017	0.108	124 ± 11		
	2.46			2.754 ± .028	0.118 ± .002	1.269 ± .017	0.102	118 ± 10		
	3.85			2.606 ± .026	0.107 ± .002	1.240 ± .016	0.095	104 ± 9		
	3.85			2.646 ± .026	0.110 ± .002	1.264 ± .017	0.096	113 ± 10		
	4.91			2.465 ± .025	0.097 ± .002	1.201 ± .016	0.088	87 ± 8		
	4.91			2.464 ± .025	0.097 ± .002	1.222 ± .016	0.087	94 ± 8		
	4.91			2.471 ± .025	0.098 ± .002	1.198 ± .016	0.088	86 ± 8		
	0.00			1.836 ± .018	0.110 ± .002					
	1.27			1.816 ± .018	0.108 ± .002					
2.46	1.760 ± .018	0.101 ± .003								
3.85	1.713 ± .017	0.094 ± .002								
3.85	1.713 ± .017	0.094 ± .002								
4.91	1.648 ± .016	0.085 ± .002								
4.91	1.632 ± .016	0.083 ± .002								
4.91	1.651 ± .017	0.086 ± .002								
Booster P.T. Mod.	5.72	Lattice center	E	2.283 ± .023	0.084 ± .002	1.777 ± .016	0.078	76 ± 7	(g)	
Cal. S.	9.33			1.960 ± .020	0.063 ± .001	1.116 ± .015	0.060	53 ± 6		
Fuel (e)	13.39			1.915 ± .019	0.060 ± .001	1.186 ± .016	0.055	73 ± 6		
15.55	1.971 ± .020			0.064 ± .001	1.224 ± .012	0.057	88 ± 5			
17.11	1.979 ± .020			0.064 ± .001	1.261 ± .013	0.057	99 ± 5			
18.59	1.946 ± .020			0.062 ± .001	1.271 ± .013	0.055	102 ± 5			
20.92	1.891 ± .019			0.058 ± .001	1.269 ± .013	0.052	100 ± 5			
22.41	1.820 ± .018			0.054 ± .001	1.246 ± .012	0.048	92 ± 5			
23.96	1.735 ± .017			0.048 ± .001	1.201 ± .012	0.044	78 ± 4			
33.08	1.452 ± .015			0.030 ± .001	1.063 ± .014	0.029	37 ± 4			
39.47	1.409 ± .014	0.027 ± .001	1.069 ± .014	0.026	39 ± 4					
Booster P.T. Mod.	5.72	Center of rod JK1E	N	2.265 ± .023	0.084 ± .002	1.166 ± .015	0.077	72 ± 7	(g)	
Cal. S.	9.97			1.885 ± .019	0.058 ± .001	1.094 ± .014	0.056	46 ± 5		
Mod.	13.97			1.727 ± .017	0.047 ± .001	1.077 ± .014	0.046	41 ± 5		
13.97	1.848 ± .018			0.055 ± .001	1.170 ± .015	0.051	70 ± 6			
10.37	1.742 ± .017			0.048 ± .001	1.093 ± .014	0.046	46 ± 5			
13.97	1.729 ± .017			0.048 ± .001	1.084 ± .014	0.046	43 ± 5			
Cal. S.	6.37			1.679 ± .017	0.044 ± .001	1.163 ± .015	0.041	66 ± 5		
Mod.	10.57			1.510 ± .015	0.033 ± .001	1.080 ± .014	0.032	42 ± 5		
13.97	1.471 ± .015			0.031 ± .001	1.070 ± .014	0.030	39 ± 4			
Thermal Pit						1.000	0.104 × 10 ⁻³	1.000		

- (a) Booster F., Booster S., Booster P.T., Mod., Cal.S. and Fuel refer to detector locations in the booster fuel pins, on booster fuel pin sheaths, on the booster pressure tube, in the moderator, on a reference assembly calandria surface, and in the reference assembly fuel pins, respectively.
- (b) Reported spectrum parameters in directions E and SE from the lattice center were obtained in part from measurements in equivalent directions N and NE.
- (c) Au/Cu of Lu/Cu ratios are ratios at the measurement position, relative to the same ratio at the thermal pit location. The $r\sqrt{T_n/T_0}$ value reported at the thermal pit was determined from a Cd ratio method with In foils.
- (d) $T_0 = T_{D2O} = 21.71°C$.
- (e) Measurement positions reported on distances measured from the lattice center, SE to the appropriate booster or Fuel ring radii.
- (f) The parameters at this position are estimates based on the parameters measured inside the pin. The strips on the sheath were loose during irradiation.
- (g) 0.775 cm diameter Au-Al, Lu-Al and Cu foil packages.
- (h) 0.5 cm wide Au and Cu strips wrapped around sheath.
- (i) 1.422 cm diameter Au-Al, Lu-Al and Cu foil packages.

TABLE 7
MEASURED NEUTRON SPECTRUM PARAMETERS
COMPARISON OF SQUARE LATTICE VERTICAL BOOSTER RESULTS

Experiment and (a) Measurement	CORE LOCATION							Thermal Pit (b)
	Booster Fuel Pin Mean at K0	Booster Sheath Surface Mean at K0	Reference Fuel Pin Mean at JK1E	Booster Pres- sure Tube Sur- face Mean at K0	Ref. Calandria Surface Mean at JK1E	K1W Perturbed Cell Edge	J2W Unperturbed Cell Corner	
<u>Case 28-10</u> 28.58 cm (D ₂ O) Ref. Lattice 1. $r/\sqrt{T_n/T_o}$ 2. r 3. $T_n(OC)$			$0.048 \pm .001$ 0.043 84 ± 5		$0.032 \pm .001$ 0.031 44 ± 3	$0.026 \pm .001$ 0.025 35 ± 3	$0.024 \pm .001$ 0.023 34 ± 3	0.184×10^{-3}
<u>Case 28-20</u> 28.58 cm (D ₂ O) Ref. Lattice & 61-element 20% ²³⁵ U Booster at K0 1. $r/\sqrt{T_n/T_o}$ 2. r 3. $T_n(OC)$	$0.107 \pm .002$ 0.094 101 ± 6	$0.088 \pm .002$	$0.054 \pm .001$ 0.049 92 ± 5	$0.082 \pm .002$ 0.076 67 ± 7	$0.047 \pm .002$ 0.044 56 ± 5	$0.045 \pm .001$ 0.043 42 ± 5	$0.024 \pm .001$ 0.024 32 ± 4	0.950×10^{-3}
<u>Case 28-30</u> 28.58 cm (D ₂ O) Ref. Lattice & 61-element 93% ²³⁵ U Booster at K0 1. $r/\sqrt{T_n/T_o}$		$0.088 \pm .002$	$0.052 \pm .001$	$0.071 \pm .002$	$0.042 \pm .001$	$0.041 \pm .001$	$0.022 \pm .001$	0.127×10^{-3}
<u>Case 27-10</u> 27.94 cm (Air) Ref. Lattice 1. $r/\sqrt{T_n/T_o}$ 2. r 3. $T_n(OC)$			$0.045 \pm .001$ 0.040 91 ± 5		$0.037 \pm .001$ 0.035 60 ± 4	$0.029 \pm .001$ 0.028 38 ± 3	$0.027 \pm .001$ 0.026 38 ± 3	0.135×10^{-3}
<u>Case 27-20</u> 27.94 cm (Air) Ref. Lattice & 61-element 20% ²³⁵ U Booster at K0 1. $r/\sqrt{T_n/T_o}$ 2. r 3. $T_n(OC)$	$0.108 \pm .002$ 0.095 105 ± 6	$0.093 \pm .002$	$0.057 \pm .001$ 0.052 89 ± 5	$0.084 \pm .002$ 0.078 74 ± 7	$0.051 \pm .001$ 0.047 69 ± 6	$0.048 \pm .001$ 0.046 46 ± 5	$0.028 \pm .001$ 0.027 39 ± 4	0.104×10^{-3}

(a) Detectors used were Au, Lu and Cu except Case 28-10 (In, Lu and Mn); see text.

(b) Cd ratio measurement with In-Al foils.

The nearness of the major Au resonance (4.91 eV) to a large ^{238}U resonance (6.68 eV) significantly depressed the Au activation, and thus $(r\sqrt{T_n/T_o})$ Au values in the reference fuel are low relative to a similar measurement with In. The unperturbed, air cooled reference lattice (Case 27-10; Au detectors) shows considerable spectral flattening in the fuel when compared with the D_2O cooled lattice (Case 28-10; In detectors). Thus the measurements indicate a higher fuel average in the D_2O lattice but in fact the reverse was correct; results at other core locations show that the spectrum was harder in the air cooled core. This effect is discussed more fully in Section 4.3.

Spectral perturbation effects were represented more clearly by defining a "spectral perturbation factor", $S(r,z)$ similar to the flux perturbation factor⁽¹²⁾:

$$S(r,z) = \frac{\left[(r\sqrt{T_n/T_o})_{r,z} / (r\sqrt{T_n/T_o})_{R,Z} \right] \text{ Perturbed lattice}}{\left[(r\sqrt{T_n/T_o})_{r,z} / (r\sqrt{T_n/T_o})_{R,Z} \right] \text{ Unperturbed lattice}}$$

where r,z refers to a core location with co-ordinates (r,z) and R,Z is a core location removed from the spectral perturbation (lattice site J2E).

Spectral perturbation factors $S(r)$ are tabulated in Appendix C and shown in Figures 21 to 23. The axial dependence was not considered since $r\sqrt{T_n/T_o}$ values were constant over the central part of the core where the measurements were made. The reference lattice Case 28-10 $(r\sqrt{T_n/T_o})_{\text{In}}$ values were converted to $(r\sqrt{T_n/T_o})_{\text{Au}}$ as discussed in Section 4.3, to ensure a consistent set of $S(r)$ values in the 28.58 cm, D_2O cooled lattices. The results indicate that spectral perturbations introduced by the boosters do not

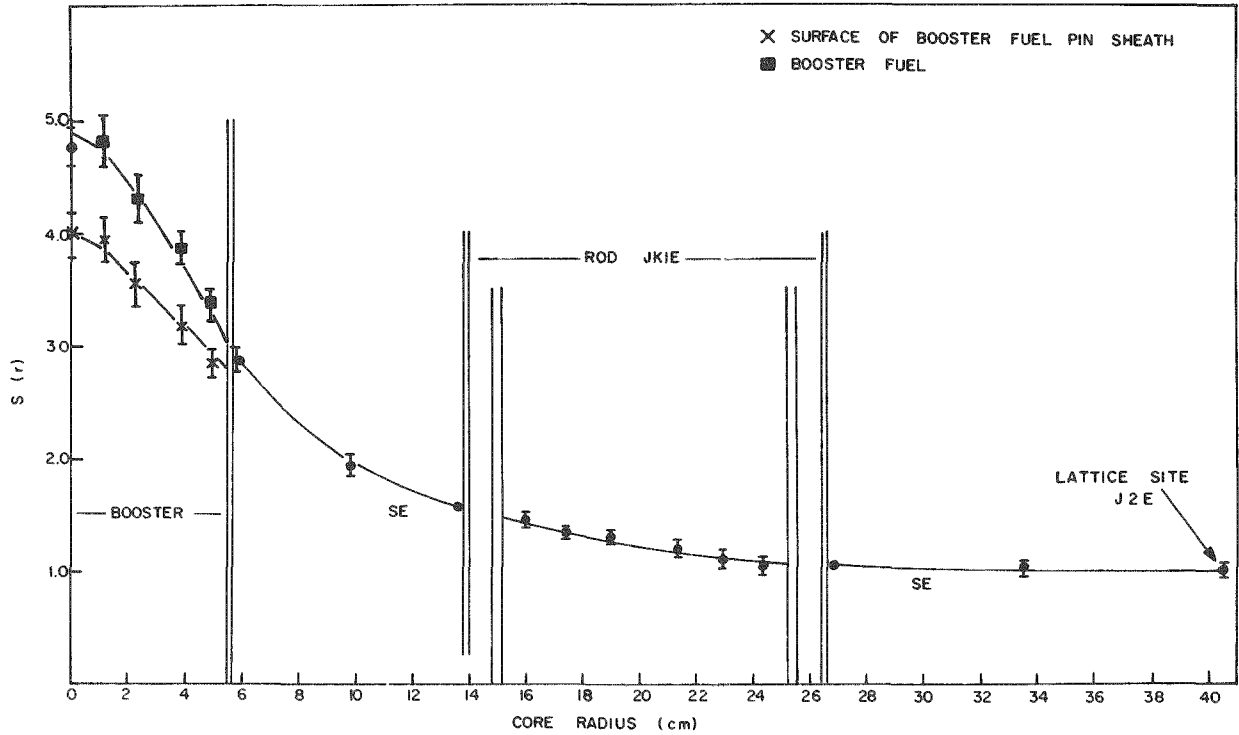

Fig. 21 Spectral perturbation factors SE of lattice center: Case 28-20

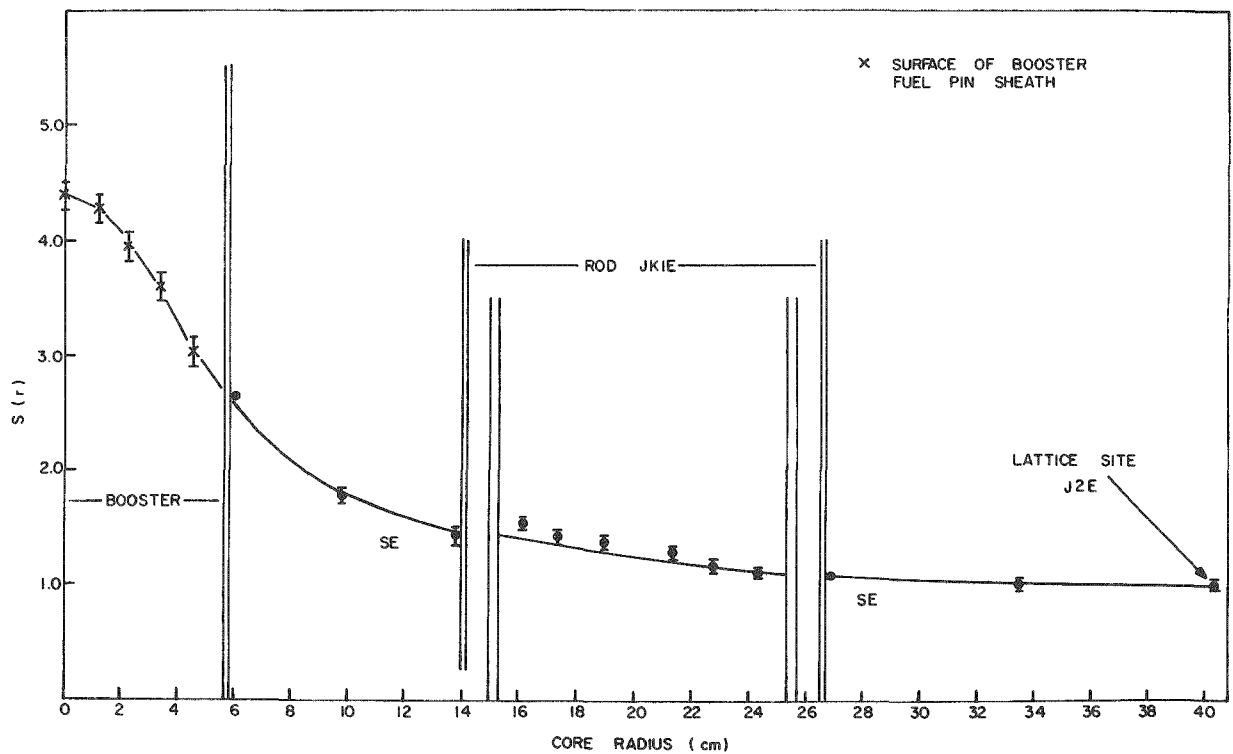

Fig. 22 Spectral perturbation factors SE of lattice center: Case 28-30

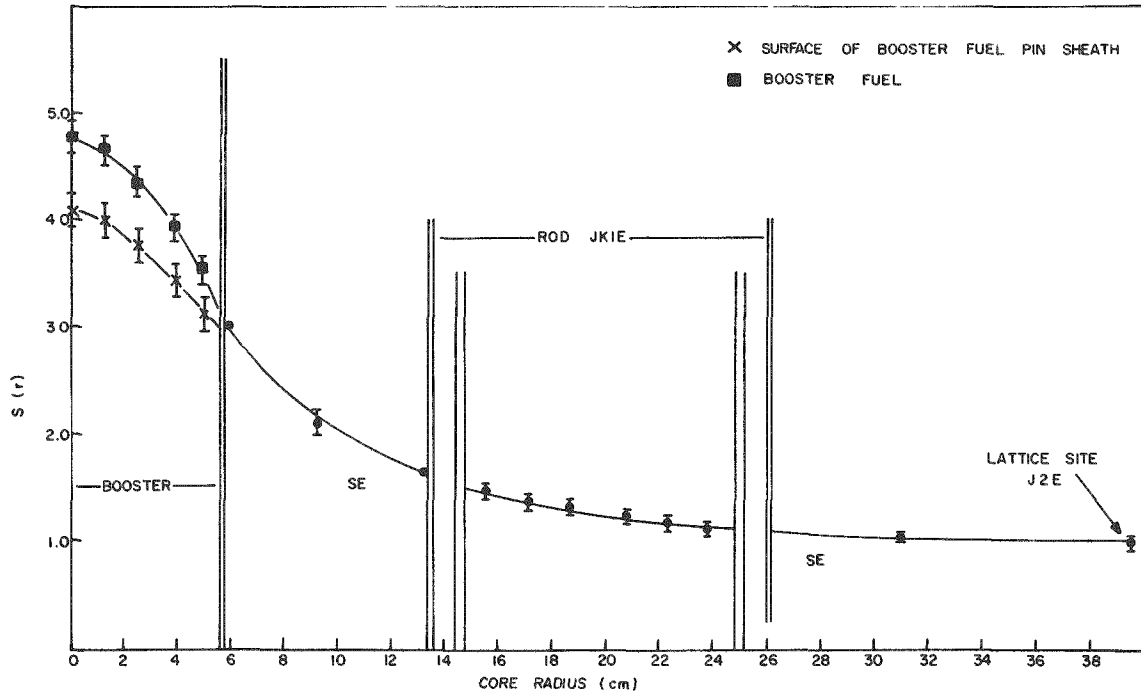

Fig. 23 Spectral perturbation factors SE of lattice center: Case 27-20

extend much more than one lattice pitch (~ two or three slowing down lengths) from the booster site; the spectral perturbation factor curves decrease smoothly toward 1.0 at lattice site J2E.

Examination of the results indicate that as expected, the spectrum with the low enrichment booster in the 27.94 cm, air cooled lattice was everywhere slightly harder than the spectrum with the same booster in the D₂O cooled lattice. The spectral perturbation factors, however, were identical within experimental error.

In the 28.58 cm, D₂O cooled lattices, $r\sqrt{T_n/T_o}$ values in the central cells immediately surrounding the 20% enriched booster were higher than corresponding values with the 93% enriched booster. Since the ²³⁵U loading was the same in each booster (within 3%) the additional spectral hardening with the low enrichment booster was likely due to thermal and resonance absorption, and fast fission effects in ²³⁸U. Within the 20% enriched booster, however, the $r\sqrt{T_n/T_o}$ values inferred from the Au activations have been depressed due to the presence of the ²³⁸U. Thus, at the booster fuel pin sheaths, the results are the same in both boosters.

4.1.2 Booster Perpendicular to Reference Fuel Assemblies

Macroscopic spectral effects in the 28.58 cm, D₂O cooled lattice with the low enrichment booster perpendicular to the reference fuel assemblies (Case 28-40) are listed in Table 8 and axial effects are shown in Figure 24. Results along the length of the booster, on the pressure tube surface, are shown in Table 9.

Axial spectral perturbations, represented by $S(r,z)$ values at radial locations JK1E and JK0, are shown in Table 10. The unperturbed normalization locations were at 175 cm and 165 cm at radial locations JK1E and JK0 respectively.

TABLE 8

MEASURED NEUTRON SPECTRUM PARAMETERS IN LATTICE

CASE 28-40: 28.58 cm (D₂O) Reference Lattice
 61-element 20% ²³⁵U Booster Perpendicular
 along K at 80 cm elevation.

Core Location		Au/Cu (a) Act. Ratio	$r\sqrt{T_n/T_o}$	Method
Location	Elevation (cm)			
JK1E Calandria Surface (West)	175	1.547 ± .015	0.036 ± .001	(b)
	155	1.536 ± .015	0.035 ± .001	
	135	1.551 ± .015	0.036 ± .001	
	115	1.545 ± .015	0.036 ± .001	
	95	1.657 ± .017	0.043 ± .001	
	75	1.765 ± .018	0.050 ± .001	
	55	1.595 ± .016	0.039 ± .001	
	35	1.518 ± .015	0.034 ± .001	
IJ3E Calandria Surface (NW)	115	1.530 ± .015	0.035 ± .001	
	75	1.528 ± .015	0.035 ± .001	
JK3W Calandria Surface (E)	115	1.531 ± .015	0.035 ± .001	
	75	1.795 ± .018	0.052 ± .001	
JK7W Calandria Surface (E)	115	1.511 ± .015	0.034 ± .001	
	75	1.648 ± .016	0.043 ± .001	
JKO	165	1.414 ± .014	0.027 ± .001	
	145	1.423 ± .014	0.028 ± .001	
	125	1.430 ± .014	0.028 ± .001	
	105	1.457 ± .015	0.030 ± .001	
	85	1.640 ± .016	0.042 ± .001	
	65	1.548 ± .016	0.036 ± .001	
JK4W	45	1.442 ± .014	0.029 ± .001	
	115	1.452 ± .015	0.030 ± .001	
I4E	75	1.665 ± .017	0.044 ± .001	
	115	1.380 ± .014	0.025 ± .001	
LO	75	1.369 ± .014	0.024 ± .001	
LMO	75	1.418 ± .014	0.028 ± .001	
MNO	75	1.434 ± .014	0.029 ± .001	
Thermal Pit		1.000	0.029 ± .001	
			0.256 × 10 ⁻³	

(a) The reported activity ratios are ratios at the measurement position relative to the same ratio at the thermal pit location. The $r\sqrt{T_n/T_o}$ value at the reference position was determined by a Cd ratio method with In foils.

(b) 0.775 cm diameter Au-Al and Cu foil packages.

TABLE 9

MEASURED NEUTRON SPECTRUM PARAMETERS AT BOOSTER ROD

CASE 28-40: 28.58 cm (D₂O) Reference Lattice
 61-element 20% ²³⁵U Booster Perpendicular
 along K at 80 cm elevation.

Distance From Center of Perpendicular Booster (cm)	Direction	Au/Cu (b) Act. Ratio	$r\sqrt{T_n/T_o}$
5.0	East	2.158 ± .022	0.077 ± .001
20.0		2.176 ± .022	0.078 ± .001
35.0		2.130 ± .021	0.072 ± .001
50.0		2.142 ± .021	0.076 ± .001
65.0		2.153 ± .022	0.076 ± .001
80.0		2.093 ± .021	0.072 ± .001
95.0		1.669 ± .017	0.044 ± .001

(a) Booster perpendicular along K direction at 85.0 cm elevation.
 Detectors located on top of booster pressure tube at 90.7 cm
 elevation.

(b) The reported activity ratios are ratios at the measurement
 position, relative to the same ratio at the thermal pit location.
 The $r\sqrt{T_n/T_o}$ value at the reference position was determined by a
 Cd ratio method with In foils. The detectors were 0.775 cm
 diameter Au-Al and Cu foil packages.

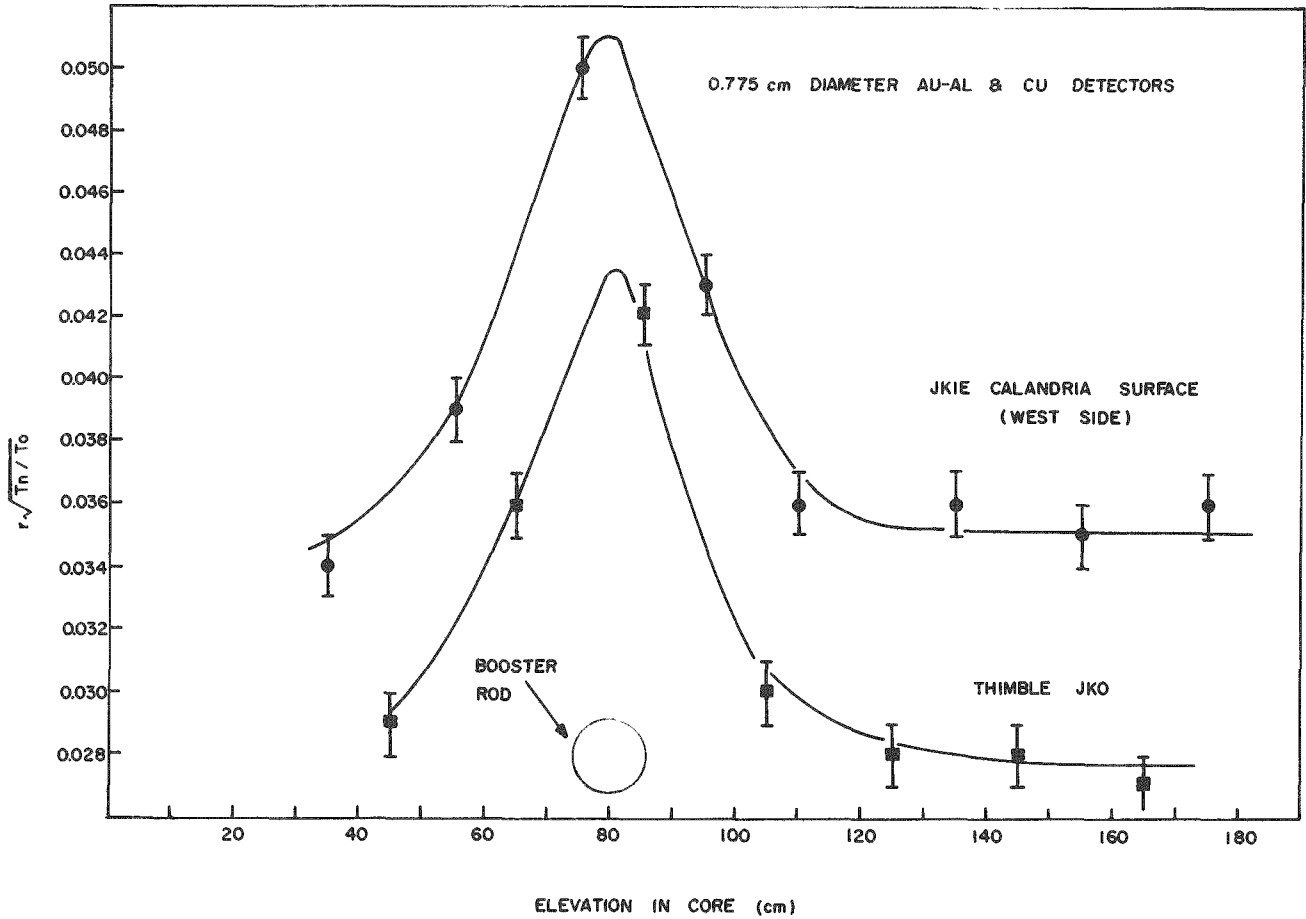

Fig. 24 $r\sqrt{T_n/T_0}$: Case 28-40

TABLE 10

AXIAL SPECTRAL PERTURBATIONS, $S(r,z)$

CASE 28-40: 28.58 cm (D₂O) Reference Lattice
 61-element 20% ²³⁵U Booster
 perpendicular along K at 80 cm elevation

Core Location	Elevation (cm)	$S(r,z)$ ± 5%	Core Location	Elevation (cm)	$S(r,z)$ ± 5%
JKIE Calandria Surface (west)	175	1.00	JKO	165	1.00
	155	1.00		145	1.00
	135	1.00		125	1.00
	115	1.00		105	1.07
	95	1.19		85	1.50
	75	1.39		65	1.29
	55	1.08		45	1.00
	35	1.00			

4.2 Interacting Booster Results

4.2.1 Boosters Parallel to Reference Fuel Assemblies

Detailed spectral results in the hexagonal 30.00 cm, D₂O cooled cores with and without three, 33-element interacting boosters parallel to the reference assemblies are tabulated in Appendix D. To facilitate direct comparison between the experiments, results in the booster and reference fuel bundles, and at representation lattice sites are shown in Table 11.

In a few cases, $r\sqrt{T_n/T_0}$ values at the booster fuel pin sheath surfaces, determined with Au and Cu strips, did not seem consistent with Au-Al and Cu foil measurements. Comparison of results between experiments suggested that the thermal reference Au-Cu strip activity determination was in error in Cases 30-24, 30-32, and 30-65 and the results have been modified. Inconsistencies were not resolved in Case 30-52D and no adjustments were made. Larger errors have been assigned to the strip $r\sqrt{T_n/T_0}$ values in these cases to reflect this uncertainty.

Here again, spectral perturbations did not extend much more than one lattice pitch from the booster sites. The central reference fuel assembly was essentially unperturbed for all configurations except the tightest booster spacing (booster pitch = 30.00 cm). In this case, the close coupling between the boosters resulted in a very large fuel average $(r\sqrt{T_n/T_0})_{Au}$ value (0.076).

TABLE 11

MEASURED NEUTRON SPECTRUM PARAMETERS
COMPARISON OF HEXAGONAL LATTICE RESULTS

EXPERIMENT	Equivalent Core Location and $r, T_N/T_O$ Measurement (a)										
	Booster Sheath Surface Mean		Reference Fuel Pin Mean		Booster Pressure Tube Surface		K0 Ref. Calandria Surface	M0 Ref. Calandria Surface	J0	NO	Thermal Pit (b)
	Location	$r, T_N/T_O$	Location	$r, T_N/T_O$	Location	$r, T_N/T_O$	$r, T_N/T_O$	$r, T_N/T_O$	$r, T_N/T_O$	$r, T_N/T_O$	$r, T_N/T_O$
<u>Case 30-10</u> 30.00 cm (D ₂ O) Ref. Lattice			K0	0.042 ± .001			0.036 ± .001	0.034 ± .001	0.027 ± .001	0.028 ± .001	0.325 × 10 ⁻³
<u>Case 30-24</u> 30.00 cm (D ₂ O) Ref. Lattice & 3, 33-element Boosters (KLO, JK1E, JK1W)	KLO	0.076 ± .003	K0	0.076 ± .002	KLO	0.068 ± .001	0.063 ± .001	0.036 ± .001	0.035 ± .001	0.028 ± .001	0.396 × 10 ⁻³
<u>Case 30-32</u> 30.00 cm (D ₂ O) Ref. Lattice & 3, 33-element Boosters (LM0, JK3E, JK2W)	LM0	0.077 ± .003	K0	0.044 ± .001	LM0	0.068 ± .001	0.038 ± .001	0.047 ± .001	0.030 ± .001	0.028 ± .001	0.386 × 10 ⁻³
<u>Case 30-42</u> (c) 30.00 cm (D ₂ O) Ref. Lattice & 3, 32-element Boosters (MN0, IJ3E, IJ3W)	MN0	0.071 ± .002	NIE	0.054 ± .001	MN0	0.067 ± .001	0.037 ± .001	0.041 ± .001	0.027 ± .001		0.359 × 10 ⁻³
<u>Case 30-50E</u> 30.00 cm (D ₂ O) Ref. Lattice with Central 19 rods voided			K0	0.044 ± .001			0.039 ± .001	0.040 ± .001	0.033 ± .001	0.031 ± .001	0.323 × 10 ⁻³
<u>Case 30-52D</u> 30.00 cm (D ₂ O) Ref. Lattice with Central 19 Rods voided & 3, 33-element Boosters (LM0, JK2E, JK2W)	LM0	0.085 ± .002 - .006	K0	0.047 ± .001	LM0	0.075 ± .001	0.042 ± .001	0.050 ± .001	0.032 ± .001	0.029 ± .001	0.359 × 10 ⁻³
<u>Case 30-65</u> 30.00 cm (D ₂ O) Ref. Lattice & 3, 17-element Boosters (LM0, JK2E, JK2W)	LM0	0.060 ± .006 - .002	K0	0.043 ± .001	LM0	0.053 ± .001	0.037 ± .001	0.043 ± .001	0.030 ± .001	0.028 ± .001	0.236 × 10 ⁻³

(a) Detectors used were Au & Cu.

(b) Cd ratio measurement with In-Al foils.

(c) The results at these measurement locations are identical within error to the symmetric booster case 30-44.

4.2.2 Boosters Perpendicular to Reference Fuel Assemblies

Spectral results in the square 28.58 cm, D₂O cooled lattice with three, 17-element boosters perpendicular to the reference fuel assemblies (Case 28.57) are listed in Table 12 and axial effects are shown in Figure 25. Results along the length of the central booster, on the pressure tube, are shown in Table 13.

Axial spectral perturbations represented by $S(r, z)$ values at radial locations JK1E and JK0, are shown in Table 14. The unperturbed, normalization locations were at 135 cm and 165 cm at radial locations JK1E and JK0 respectively.

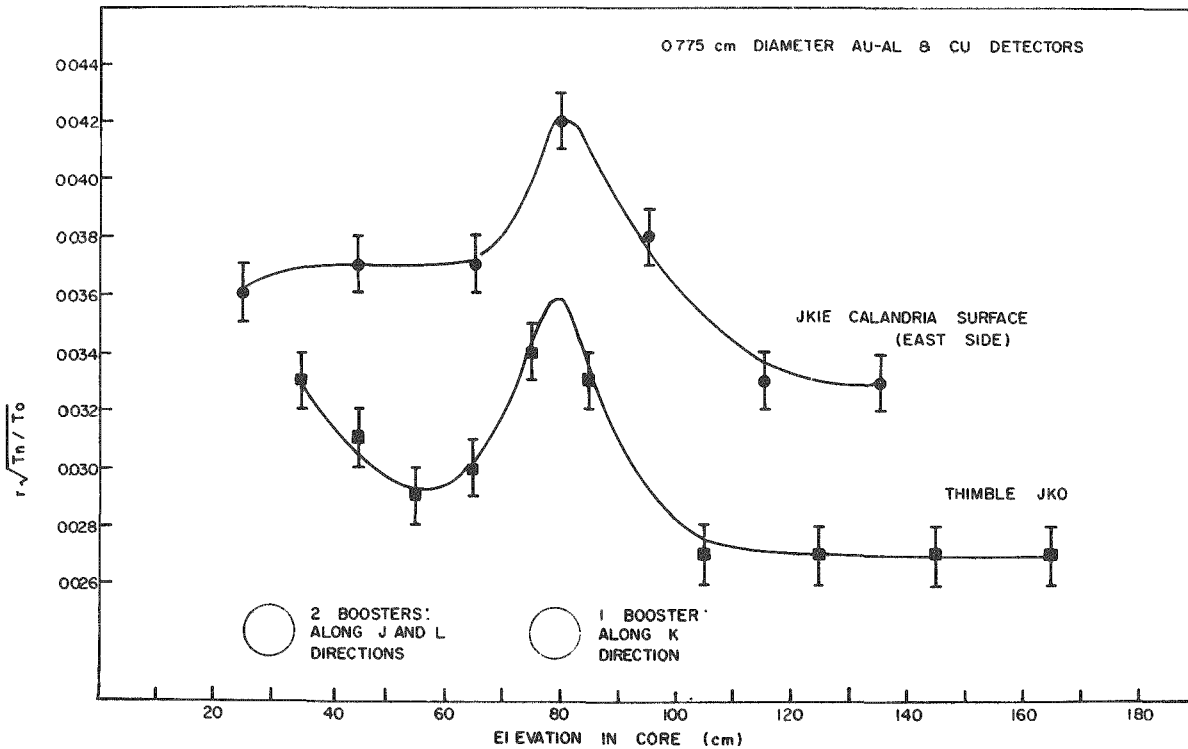

Fig. 25 Axial $r\sqrt{T_n/T_o}$: Case 28-57

TABLE 12

MEASURED NEUTRON SPECTRUM PARAMETERS IN LATTICE

CASE 28-57: 28.58 cm (D₂O) Reference Lattice
3, 17-element Interaction Boosters
Perpendicular (a).

Core Location		Elevation (cm)	Au/Cu (b) Act. Ratio	$r\sqrt{T_n/T_o}$	Method	
Location						
JK1E Fuel:	Outer Ring (W)	48.1	1.607 ± .016	0.040 ± .001	(c)	
	Middle Ring (W)		1.685 ± .017	0.045 ± .001		
	Inner Ring (W)		1.715 ± .017	0.047 ± .001		
	Inner Ring (E)		1.729 ± .017	0.048 ± .001		
	Middle Ring (E)		1.686 ± .017	0.045 ± .001		
	Outer Ring (E)		1.623 ± .016	0.041 ± .001		
	Fuel Average		1.650 ± .010	0.043 ± .001		
JK1E Calandria Surface (East)	135	135	1.509 ± .015	0.033 ± .001	(d)	
	115		1.512 ± .015	0.033 ± .001		
	95		1.579 ± .016	0.038 ± .001		
	80		1.639 ± .016	0.042 ± .001		
	65		1.562 ± .016	0.037 ± .001		
	45		1.568 ± .016	0.037 ± .001		
	25		1.554 ± .016	0.036 ± .001		
	H11E Calandria Surface (E)		80	1.505 ± .015		0.033 ± .001
	IJ1E Calandria Surface (N)		80	1.514 ± .015		0.034 ± .001
	JK3W Calandria Surface (E)		80	1.659 ± .017		0.043 ± .001
	JK5W Calandria Surface (E)		80	1.582 ± .016		0.038 ± .001
JK7W Calandria Surface (E)	80	1.604 ± .016	0.039 ± .001			
JK0	165	165	1.406 ± .014	0.027 ± .001		
	145		1.416 ± .014	0.027 ± .001		
	125		1.414 ± .014	0.027 ± .001		
	105		1.417 ± .014	0.027 ± .001		
	85		1.502 ± .015	0.033 ± .001		
	75		1.516 ± .015	0.034 ± .001		
	65		1.465 ± .015	0.030 ± .001		
	55		1.438 ± .014	0.029 ± .001		
	45		1.470 ± .015	0.031 ± .001		
	35		1.507 ± .015	0.033 ± .001		
H6E	65	1.114 ± .011	0.008 ± .001			
I4E	65	1.363 ± .014	0.024 ± .001			
M0	65	1.367 ± .014	0.024 ± .001			
MNO	65	1.406 ± .014	0.027 ± .001			
N0	65	1.362 ± .014	0.024 ± .001			
N00	65	1.406 ± .014	0.027 ± .001			
Thermal Pit			1.000	0.156 x 10 ⁻³		

- (a) 2 boosters along J and L at 30.5 cm elevation and 1 booster along K direction at 80.0 cm elevation.
- (b) The reported activity ratios are ratios at the measurement positions, relative to the same ratio at the thermal pit location. The $r\sqrt{T_n/T_o}$ value at the reference position was determined by a Cd ratio method with In foils.
- (c) 1.422 cm diameter Au-Al and Cu foil packages.
- (d) 0.775 cm diameter Au-Al and Cu foil packages.

TABLE 13

MEASURED NEUTRON SPECTRUM PARAMETERS AT BOOSTER ROD

CASE 28-57: 28.58 cm (D₂O) Reference Lattice
 3, 17-element Interaction Boosters
 Perpendicular ^(a)

Distance From Center (b) of Perpendicular Booster (cm)	Direction	Au/Cu (c) Act. Ratio	$r\sqrt{T_n/T_o}$
7.0	West	1.764 ± .018	0.050 ± .001
28.6		1.679 ± .017	0.044 ± .001
49.2		1.811 ± .018	0.053 ± .001
57.2		1.696 ± .017	0.046 ± .001
71.4		1.824 ± .018	0.054 ± .001
85.7		1.698 ± .017	0.046 ± .001
100.0		1.707 ± .017	0.046 ± .001

- (a) 2 boosters along J and L direction at 30.5 cm elevation and 1 booster along K at 80.0 cm elevation.
- (b) Booster perpendicular along K direction. Detectors located on north side of booster pressure tube at 80.0 cm elevation.
- (c) The reported activity ratios are ratios at the measurement position, relative to the same ratio at the thermal pit location. The $r\sqrt{T_n/T_o}$ value at the reference position was determined by a Cd ratio method with In foils. The detectors were 0.775 cm diameter Au-Al and Cu foil packages.

TABLE 14

AXIAL SPECTRAL PERTURBATIONS, S(r,z)

CASE 28-57: 28.58 cm (D₂O) Reference Lattice
 3, 17-element Interaction Boosters perpendicular^(a)

Core Location	Elevation	S(r,z) ± 5%	Core Location	Elevation	S(r,z) ± 5%
JK1E Calandria Surface (East)	135	1.00	JK0	165	1.00
	115	1.00		145	1.00
	95	1.15		125	1.00
	80	1.27		105	1.00
	65	1.12		85	1.22
	45	1.12		75	1.26
	25	1.09		65	1.11
				55	1.07
				45	1.15
				35	1.22

(a) 2 boosters along J and L at 30.5 cm elevation and 1 booster along K direction at 80.0 cm elevation.

4.3 Detector Normalization Experiment

The spectral results of the experiment in the 28.58 cm D₂O cooled square lattice, with the high enrichment booster parallel to the fuel assemblies at lattice site K0, are shown in Table E-1 in Appendix E. The 1.422 cm diameter In-Al, Lu-Mn-Al foil package results are compared with the results from 1.422 and 0.775 cm diameter Au-Al, Lu-Al and Cu and Au-Al, Cu detector packages at various cell and lattice sites near the center of the core.

At each location, the Au-Cu strips $r\sqrt{T_n/T_o}$ results were consistently about 10% higher than the corresponding Au-Al foil package results. There is some uncertainty in the determination of the resonance self shielding factor, G_r , and since the resonance self shielding for pure Au is high, it was concluded that the G_r value (0.483) was in error. Thus the Au-Cu strip results were normalized to agree with the Au-Al foil package results by adjusting G_r and these normalized values are shown in the table. The adjusted G_r for Au strips (0.524) was used in all determinations of $r\sqrt{T_n/T_o}$ in this report.

The results also show clearly the depression of the Au detector r and $r\sqrt{T_n/T_o}$ parameters, relative to In, in the vicinity of ²³⁸U. The effect is quite localized, however. Large discrepancies occur within a 28-element natural UO₂ fuel bundle but at the UO₂ assembly calandria tube surface, no difference between methods could be detected, within error.

At the booster fuel pin sheath surface, booster pressure tube surface, and lattice sites KlE or KlW near the booster, $(r\sqrt{T_n/T_o})_{Au}$ was higher than $(r\sqrt{T_n/T_o})_{In}$. The spectrum at the booster was very "hard" and the higher measured spectrum with Au was presumably due to the higher Au resonance energy (4.91 eV) compared with In (1.44 eV). At moderator locations removed from the booster, spectral parameters measured with Au or In were the same, within experimental error. The neutron temperature, T_n , determined by both methods agree within the large errors quoted.

The data from Table E-1 was used to convert the $r\sqrt{T_n/T_o}$ values determined with In (Table 2) to a set of values corresponding to a Au measurement, for the 28.58 cm D₂O cooled reference lattice experiment (Case 28-10). These adjusted values (Table E-2) were used to generate a consistent set of spectral perturbation factors $S(r)$ discussed in Section 4.1.

5. SUMMARY AND CONCLUSIONS

Measurements were made in ZED-2 with four types of ^{235}U boosters. One type was nominally 20% enriched ^{235}U (4.74 g ^{235}U /cm length); the other three were 93% enriched ^{235}U with ^{235}U loadings of 2.21, 3.49 and 4.88 g/cm length. The boosters were located interstitially, parallel to reference fuel assemblies; in some experiments, three boosters were inserted in three symmetric configurations that varied the flux coupling between boosters. Experiments were also done with one or three booster assemblies perpendicular to the reference assemblies. Three reference lattice configurations were used.

Relative gold-copper, lutetium-copper or indium-manganese, lutetium manganese activity ratios were experimentally determined in the regions surrounding the booster assemblies. In some cases, detailed fine structure measurements were made in the booster and neighboring reference fuel assembly cells. These activity ratios were interpreted in terms of Westcott spectrum parameters r and T_n or $r\sqrt{T_n/T_0}$.

The results show that spectral perturbation effects did not extend much beyond one lattice pitch (two or three lattice slowing down lengths) from a booster site, for all configurations of one or three boosters studied. However, the boosters were strong fast neutron sources and heavy thermal neutron sinks. In the immediate vicinity of the boosters, and in neighboring reference fuel assemblies, the spectrum was quite hard. The fuel pin average $r\sqrt{T_n/T_0}$ values of reference fuel assemblies nearest the boosters were typically ~ 30% higher than when unperturbed. In one case with three tightly spaced boosters around one reference fuel assembly, the fuel average $r\sqrt{T_n/T_0}$ was 80% higher.

The spectral perturbation introduced by the 20% enriched booster was somewhat larger than that of the 93% enriched assembly (equivalent ^{235}U content) due to additional absorption and fast fission effects in the ^{238}U .

These spectral parameter results, based on gold activations, are depressed in the immediate vicinity of fuels containing appreciable ^{238}U since the major gold resonance energy is close to a large ^{238}U resonance. Moreover, the results are not directly applicable to power reactors due to differences in reactor configuration, booster design, and operating conditions. Nevertheless, the results can provide useful information for development work with multi-group codes used to describe boosted cores.

ACKNOWLEDGEMENTS

The author wishes to thank the many people associated with the experiments and with the production of the report, in particular to P.D.J. Ferrigan, E. Pleau, and D. Roberts who helped perform the experiments, D.A. Kettner who counted the detectors, Mrs. A. Brum who prepared the diagrams and graphs, and helped with the analysis and typing of tables, Mrs. G.D. Clark and Mrs. N.G. Hulbert who typed the text and tables, G. Stratford and S.L. Mehta who assisted with the analysis, A.A. Pasanen and M.H.M. Roshd who suggested the experimental program, A. Okazaki and R.E. Kay who gave advice during the analysis, and E. Critoph who gave advice on the experimental program and criticised the manuscript.

REFERENCES *

1. M.H.M. Roshd, "Gentilly BLW Booster Rod Experiments in the ZED-2 Reactor", AECL-3258 (1969).
2. K.J. Serdula and R.E. Green, "Lattice Measurements with 28-element Natural UO₂ Fuel Assemblies - Part II : Relative Total Neutron Densities and Hyperfine Activity Distributions in a Lattice Cell", AECL-2772 (1967).
3. R.E. Green and C.B. Bigham, "Lattice Parameter Measurements in ZED-2", Proc. IAEA Symp. Experimental and Critical Experiments, Amsterdam (1963), II, 457-477 (1964).
4. A. Okazaki, private communication (1971).
5. P. Purvis and W.R. Leach, Private Communication (1970)
6. C.H. Westcott, "Effective Cross Section Values for Well-moderated Thermal Reactor Spectra", AECL-1101 (1964).
7. C.B. Bigham et al., "Experimental Effective Fission Cross Sections and Neutron Spectra in a Uranium Fuel Rod - Part II : CANDU-type Uranium Oxide Clusters", AECL-1350 (1961).
8. S.L. Mehta, private communication (1970).
9. G.C. Hanna, "The Neutron Flux Perturbation Due to an Absorbing Foil: A Comparison of Theories and Experiment", Nuc. Sci. Eng. 15, 325 (1963).
10. W.H. Walker et al., "Measurement of Radioactive Capture Resonance Integrals in a Thermal Reactor Spectrum, and the Thermal Cross Section of Pu²⁴⁰", Can. J. Phys. 38, 57 (1960).
11. J.E. Suich and H.C. Honeck, "The HAMMER System - Heterogeneous Analysis by Multigroup Methods of Exponentials and Reactors", USAEC Report DP-1064 (1967).
12. R.E. Kay and R.E. Green, "CANDU Booster Rod Experiment in ZED-2", AECL-2525 (1965).

* AECL-XXX: Published report by Atomic Energy of Canada Ltd.

TABLE A-1
DETECTOR PARAMETERS (a)

Foil Type	Diameter (cm)	Foil Thickness mg/cm ² (cm)	Activity Detected	Westcott Parameters		Self Shielding Factors		
				g	S _o	G _t	G _r	G _r S _o
Cu	0.775	114 (0.013)	Cu ⁶⁴	1.000		0.997		0.613
Cu	1.422	114 (0.013)	Cu ⁶⁴	1.000		0.992		0.613
Cu Strip	0.5 cm wide	114 (0.013)	Cu ⁶⁴	1.000		0.993		0.613
Au	1.422	24.6 (0.0013)	Au ¹⁹⁸	1.006	17.50	0.979	0.483 ^(d)	8.45
Au Strip	0.5 cm wide	24.6 (0.0013)	Au ¹⁹⁸	1.006	17.50	0.979	0.483 ^(d)	8.45
1% Au-Al	0.775 & 1.422	69 (0.025)	Au ¹⁹⁸	1.006	17.50	0.999	0.969	16.96
10% Lu-Al	0.775 & 1.422	39 (0.013)	Lu ¹⁷⁷	(b)	(b)	0.995	0.992 ^(c)	
5% Mn-10% Lu-Al	1.422	72 (0.025)	Mn ⁵⁶ Lu ¹⁷⁷	1.000 (b)	0.735 (b)	0.987 0.987	0.960 0.991 ^(c)	
1% In-Al	1.422	35.5 (0.013)	In ^{116m}	1.023	18.80	0.997	0.952	17.90

(a) Determined by S.L. Mehta.

(b) Parameters vary with neutron energy.

(c) Calculated for values of 0.143 eV resonance only.

(d) Preliminary value; detector normalizations yielded 0.524 which was used in all calculations in this report.

Properties of Neutron Detector Foils

APPENDIX A

APPENDIX B

Macroscopic Neutron Spectrum Results :
61-element Boosters Parallel to Reference Fuel Assemblies

TABLE B-1

MACROSCOPIC MEASURED NEUTRON SPECTRUM PARAMETERS

CASE 28-10: 28.58 cm (D₂O) Reference Lattice

Core Location	(a) In/Mn Act. Ratio	(b) $r\sqrt{T_n/T_o}$	(a) Lu/Mn Act. Ratio	r	T _n (°C)	Method
K1W	1.423 ± .014	0.026 ± .001	1.056 ± .011	0.025	35 ± 3	(c)
J2W	1.390 ± .014	0.024 ± .001	1.051 ± .011	0.023	34 ± 3	
L0	1.380 ± .014	0.023 ± .001	1.049 ± .010	0.022	33 ± 3	
I4E	1.369 ± .014	0.022 ± .001	1.040 ± .010	0.022	31 ± 3	
KL2W	1.440 ± .014	0.026 ± .001	1.069 ± .011	0.026	39 ± 3	
KL2W	1.416 ± .014	0.025 ± .001	1.059 ± .011	0.024	36 ± 3	
H6E	1.132 ± .011	0.008 ± .001	1.022 ± .010	0.008	26 ± 3	
Thermal Pit -KL12W	1.000	0.184 × 10 ⁻³	1.000		21.01	

(a) The reported activity ratios are ratios at the measurement position, relative to the same ratio at the thermal pit location. The $r\sqrt{T_n/T_o}$ value reported at the thermal pit was determined from a ¹⁰⁹Cd ratio method with In foils.

(b) T_o = T_{D₂O} = 21.01 °C.

(c) 1.422 cm diameter Lu-Mn-Al and In-Al foil package.

TABLE B-2

MACROSCOPIC MEASURED NEUTRON SPECTRUM PARAMETERS

CASE 28-20: 28.58 cm (D₂O) Reference Lattice

61-element 20% ²³⁵U Booster at K0

Core Location	Au/Cu or (a) In/Mn Act. Ratio	$r\sqrt{T_n/T_o}$ (b)	Lu/Cu or (a) Lu/Mn Act. Ratio	r	T _n (°C)	Method
K1W	1.688 ± .022	0.045 ± .001	1.085 ± .014	0.043	42 ± 5	(c)
J2W	1.370 ± .018	0.024 ± .001	1.048 ± .014	0.024	32 ± 4	
L0	1.404 ± .019	0.026 ± .001	1.063 ± .014	0.026	36 ± 4	
I4E	1.378 ± .018	0.025 ± .001	1.044 ± .014	0.024	31 ± 4	
KL6W	1.435 ± .019	0.028 ± .001	1.061 ± .014	0.028	36 ± 4	
	1.445 ± .019	0.029 ± .001	1.053 ± .014	0.028	33 ± 4	
	1.462 ± .019	0.030 ± .001	1.072 ± .014	0.029	39 ± 4	
	1.406 ± .019	0.027 ± .001	1.046 ± .014	0.029	31 ± 4	
	1.424 ± .014	0.028 ± .001	1.059 ± .011	0.027	35 ± 3	(d)
	1.428 ± .014	0.026 ± .001	1.046 ± .001	0.025	32 ± 3	(e)
	1.224 ± .012	0.031 ± .002				(f)
	1.523 ± .020	0.034 ± .001	1.109 ± .015	0.033	49 ± 5	(c)
JK3W (W) Cal. Surface	1.558 ± .021	0.036 ± .001	1.122 ± .015	0.034	53 ± 5	
	1.524 ± .014	0.034 ± .001	1.131 ± .011	0.032	55 ± 4	(d)
	1.544 ± .015	0.033 ± .001	1.085 ± .011	0.032	43 ± 3	(e)
	1.244 ± .012	0.034 ± .002				(f)
	1.128 ± .015	0.009 ± .001	1.032 ± .014	0.009	29 ± 4	(c)
H6E Thermal Pit ~KL12W	1.000	0.950 x 10 ⁻³	1.000		20.95	

(a) The reported activity ratios are ratios at the measurement position, relative to the same ratio at the thermal pit location. The $r\sqrt{T_n/T_o}$ value reported at the thermal pit was determined from a Cd ratio method with In foils.

(b) T_o = T_{D₂O} = 20.95°C.

(c) 0.775 cm diameter Au-Al, Lu-Al and Cu foil packages.

(d) 1.422 cm diameter Au-Al, Lu-Al and Cu foil packages.

(e) 1.422 cm diameter Lu-Mn-Al and In-Al foil packages.

(f) 0.5 cm wide Au and Cu strips.

TABLE B-3
MACROSCOPIC MEASURED NEUTRON SPECTRUM PARAMETERS

CASE 28-30: 28.58 cm (D₂O) Reference Lattice
 61-clement 93% ²³⁵U Booster at K0

Core Location	Au/Cu or (a) In/Mn Act. Ratio	$r \sqrt{T_n/T_o}$ (b)	Lu/Cu or (a) Lu/Mn Act. Ratio	r	T _n (°C)	Method
K1W	1.626 ± .022	0.041 ± .001				(c)
J2W	1.332 ± .018	0.022 ± .001				
I4E	1.329 ± .018	0.022 ± .001				
K4W	1.351 ± .014	0.023 ± .001				(d)
	1.383 ± .014	0.023 ± .001	1.047 ± .010	0.023	32 ± 3	(e)
JK2W	1.416 ± .014	0.027 ± .001				(d)
	1.429 ± .014	0.028 ± .001	1.052 ± .011	0.027	33 ± 3	(f)
	1.435 ± .014	0.026 ± .001	1.063 ± .011	0.026	37 ± 3	(e)
H6E	1.100 ± .015	0.007 ± .001				(c)
Thermal Pit ~ KL12W	1.000	0.127 x 10 ⁻³	1.000		21.24	

(a) The reported activity ratios are ratios at the measurement position, relative to the same ratio at the thermal pit location. The $r \sqrt{T_n/T_o}$ value reported at the thermal pit was determined from a Cd ratio method with In foils.

(b) $T_o = T_{D_2O} = 21.24^\circ\text{C}$.

(c) 0.775 cm diameter Au-Al and Cu foil packages.

(d) 1.422 cm diameter Au-Al and Cu foil packages.

(e) 1.422 cm diameter Lu-Mn-Al and In-Al foil packages.

(f) 1.422 cm diameter Au-Al, Lu-Al and Cu foil packages.

TABLE B-4
 MACROSCOPIC MEASURED NEUTRON SPECTRUM PARAMETERS

CASE 27-10: 27.94 cm (AIR) Reference Lattice

Core Location	Au/Cu or (a) In/Mn Act. Ratio	$r\sqrt{T_n/T_o}$ (b)	Lu/Cu or (a) Lu/Mn Act. Ratio	r	T_n (°C)	Method
K1W	1.449 ± .014	0.029 ± .001	1.066 ± .011	0.028	38 ± 3	(c)
J2W	1.409 ± .014	0.027 ± .001	1.066 ± .011	0.026	38 ± 3	
L0	1.408 ± .014	0.027 ± .001	1.068 ± .011	0.026	39 ± 3	
I4E	1.402 ± .014	0.026 ± .001	1.060 ± .011	0.026	37 ± 3	
KL2W	1.469 ± .015	0.031 ± .001	1.059 ± .011	0.030	36 ± 3	
	1.455 ± .015	0.030 ± .001	1.071 ± .011	0.029	40 ± 3	
JK3W Calandria Surface	1.497 ± .015	0.030 ± .001	1.064 ± .011	0.029	38 ± 3	(d)
	1.472 ± .015	0.031 ± .001	1.066 ± .011	0.030	38 ± 3	(e)
	1.564 ± .016	0.037 ± .001	1.145 ± .011	0.034	61 ± 4	(c)
Thermal Pit ~ KL12W	1.573 ± .016	0.037 ± .001	1.145 ± .011	0.035	61 ± 4	
	1.679 ± .017	0.041 ± .001	1.147 ± .011	0.038	63 ± 4	(d)
	1.615 ± .016	0.040 ± .001	1.160 ± .012	0.037	65 ± 4	(e)
	1.000	0.135×10^{-3}	1.000		21.96	

(a) The reported activity ratios are ratios at the measurement position, relative to the same ratio at the thermal pit location. The $r\sqrt{T_n/T_o}$ value reported at the thermal pit was determined from a Cd ratio method with In foils.

(b) $T_o = T_{D_2O} = 21.96^\circ\text{C}$.

(c) 0.775 cm diameter Au-Al, Lu-Al and Cu foil packages.

(d) 1.422 cm diameter Lu-Mn-Al and In-Al foil packages.

(e) 1.422 cm diameter Au-Al, Lu-Al and Cu foil packages.

TABLE B-5

MACROSCOPIC MEASURED NEUTRON SPECTRUM PARAMETERS

CASE 27-20: 27.94 cm (AIR) Reference Lattice
61-element 20% ²³⁵U Booster at K0

Core Location	Au/Cu or (a) In/Mn Act. Ratio	(b) $r\sqrt{T_n/T_o}$	Lu/Cu or (a) Lu/Mn Act. Ratio	r	T _n (°C)	Method
K1W	1.733 ± .017	0.048 ± .001	1.094 ± .014	0.046	46 ± 5	(c)
J2W	1.426 ± .014	0.028 ± .001	1.071 ± .014	0.027	39 ± 4	
L0	1.442 ± .014	0.029 ± .001	1.074 ± .014	0.028	40 ± 4	
I4E	1.388 ± .014	0.025 ± .001	1.066 ± .014	0.025	38 ± 4	
KL6W	1.448 ± .014	0.029 ± .001	1.064 ± .014	0.028	37 ± 4	
	1.461 ± .015	0.030 ± .001	1.074 ± .014	0.029	40 ± 4	
	1.456 ± .015	0.030 ± .001	1.072 ± .014	0.029	40 ± 4	
	1.469 ± .015	0.031 ± .001	1.047 ± .010	0.030	33 ± 3	(d)
	1.467 ± .015	0.028 ± .001	1.038 ± .010	0.028	31 ± 3	(e)
	1.235 ± .012	0.033 ± .002				(f)
JK3W Cal. Surface	1.577 ± .016	0.038 ± .001	1.159 ± .015	0.035	64 ± 5	(c)
	1.574 ± .016	0.037 ± .001	1.160 ± .015	0.035	65 ± 5	
	1.580 ± .016	0.038 ± .001	1.126 ± .011	0.036	55 ± 4	(d)
	1.684 ± .016	0.039 ± .001	1.115 ± .011	0.037	53 ± 4	(e)
	1.283 ± .013	0.039 ± .002				(f)
H6E	1.112 ± .011	0.008 ± .001	1.028 ± .014	0.008	29 ± 4	(c)
Thermal Pit ~KL12W	1.000	0.104 × 10 ⁻³	1.000		21.71	

- (a) The reported activity ratios are ratios at the measurement position, relative to the same ratio at the thermal pit location. The $r\sqrt{T_n/T_o}$ value reported at the thermal pit was determined by a Cd ratio method with In foils.
- (b) $T_o = T_{D_2O} = 21.71^\circ\text{C}$.
- (c) 0.775 cm diameter Au-Al, Lu-Al and Cu foil packages.
- (d) 1.422 cm diameter Au-Al, Lu-Al, and Cu foil packages.
- (e) 1.422 cm diameter Lu-Mn-Al and In-Al foil packages.
- (f) 0.5 cm wide Au and Cu strips.

APPENDIX C

Spectral Perturbation Factor Results :
61-element Boosters Parallel to Reference Fuel Assemblies

TABLE C-1

DETAILED SPECTRAL PERTURBATION FACTORS, S(r), SE OF LATTICE CENTER

CASE 28-20: 28.58 cm (D₂O) Reference Lattice
61-element 20% ²³⁵U Booster at K0

Distance From Lattice Center (cm)	Location	S(r) ± 5%	Distance From Lattice Center (cm)	Location	S(r) ± 5%
0.00	Booster F.	4.76	5.72	Booster P.T. Mod.	2.88
1.27		4.83	9.78		1.97
2.46		4.31	13.84	Cal. Surface	1.57
3.85		3.88	16.00	Fuel	1.48
4.19		3.39	17.56		1.36
0.00	Booster S.	3.99	19.05		1.32
1.27		3.95	21.37		1.20
2.46		3.54	22.86		1.12
3.85		3.16	24.42		1.04
4.19		2.82	26.58	Cal. Surface	1.09
			33.53	Mod.	1.03
			40.47		1.00

TABLE C-2

DETAILED SPECTRAL PERTURBATION FACTORS, S(r), SE OF LATTICE CENTER

CASE 28-30: 28.58 cm (D₂O) Reference Lattice
61-element 93% ²³⁵U Booster at K0

Distance From Lattice Center (cm)	Location	S(r) ± 5%	Distance From Lattice Center (cm)	Location	S(r) ± 5%
0.00	Booster S.	4.38	16.00	Fuel	1.53
1.15		4.29	17.56		1.43
2.22		3.96	19.05		1.38
3.31		3.60	21.37		1.28
4.43		3.04	22.86		1.17
5.72	Booster P.T. Mod	2.73	24.42		1.10
9.78		1.76	26.58	Cal. Surface	1.06
13.84	Cal. Surface	1.44	33.53	Mod.	1.00
			40.47		1.00

TABLE C-3

DETAILED SPECTRAL PERTURBATION FACTORS, S(r), SE OF LATTICE CENTER

CASE 27-20: 27.94 cm (AIR) Reference Lattice
 61-element 20% ²³⁵U Booster at K0

Distance From Lattice Center (cm)	Location	S(r) ± 5%	Distance From Lattice Center (cm)	Location	S(r) ± 5%
0.00	Booster F.	4.78	5.72	Booster P.T.	3.00
1.27		4.67	9.33	Mod.	2.10
2.46		4.37	13.39	Calandria Surface	1.62
3.85		3.95	15.55	Fuel	1.49
4.91		3.53	17.11		1.36
0.00	Booster S.	4.08	18.59		1.32
1.27		4.00	20.92		1.23
2.46		3.74	22.41		1.17
3.85		3.41	23.96		1.12
4.91		3.09	33.08	Mod.	1.03
			39.47		1.00

APPENDIX D

Neutron Spectrum Results :
33-element and 17-element Interacting Boosters Parallel
to Reference Fuel Assemblies

TABLE D-1

MEASURED NEUTRON SPECTRUM PARAMETERS

CASE 30-10 : 30.00 cm (D₂O) Hex Ref. Lattice

Core Location	Au/Cu ^(b) Act. Ratio	$r/T_n/T_o$ (c)	Method
KO: Fuel Pin 1	1.584 ± .016	0.039 ± .001	(d)
2	1.654 ± .017	0.043 ± .001	
3	1.692 ± .017	0.046 ± .001	
4	1.685 ± .017	0.045 ± .001	
5	1.666 ± .017	0.044 ± .001	
6	1.616 ± .016	0.041 ± .001	
KO (E) (a) Calandria Surface	1.546 ± .015	0.036 ± .001	(e)
L1E (S) " "	1.524 ± .015	0.035 ± .001	
MO (E) " "	1.519 ± .015	0.034 ± .001	
N1E (N) " "	1.529 ± .015	0.034 ± .001	
OO (E) " "	1.473 ± .015	0.031 ± .001	
LO	1.414 ± .014	0.027 ± .001	
M1E	1.401 ± .014	0.027 ± .001	
NO	1.426 ± .014	0.028 ± .001	
O1E	1.387 ± .014	0.026 ± .001	
K1W	1.400 ± .014	0.027 ± .001	
K1W	1.404 ± .014	0.027 ± .001	(d)
Thermal Pit (~EO)	1.000	0.335 × 10 ⁻³	

- (a) East side of fuel rod calandria surface at core location KO.
- (b) The reported activity ratios are ratios at the measurement position, relative to the same ratio at the thermal pit location. The $r/T_n/T_o$ value reported at the thermal pit was determined from a Cd ratio with In foils.
- (c) $T_o = T_{D_2O} = 21.46^\circ\text{C}$.
- (d) 1.422 cm diameter Au-Al, Lu-Al, and Cu foil packages.
- (e) 0.775 cm diameter Au-Al, Lu-Al, and Cu foil packages.

TABLE D-2

MEASURED NEUTRON SPECTRUM PARAMETERS

CASE 30-24: 30.00 cm (D₂O) Hex Ref. Lattice
3,33-element Boosters at KLO, JK1E, JK1W

Core Location	Au/Cu ^(b) Act. Ratio	$r\sqrt{T_n/T_o}$ ^(c)	Method
KLO: Booster Pin Sheath 1	1.613 ± .016	0.082 ± .003	(d)
2	1.571 ± .016	0.076 ± .003	
3	1.577 ± .016	0.077 ± .003	
4	1.559 ± .016	0.075 ± .003	
5	1.491 ± .015	0.066 ± .003	
6	1.478 ± .015	0.064 ± .003	
KO: Fuel Pin 1	2.109 ± .021	0.074 ± .001	(e)
2	2.184 ± .022	0.079 ± .002	
3	2.231 ± .022	0.082 ± .002	
4	2.217 ± .022	0.081 ± .002	
5	2.167 ± .022	0.078 ± .001	
6	2.099 ± .021	0.073 ± .001	
KO (E) ^(a) Calandria Surface	1.957 ± .020	0.063 ± .001	(f)
KLO (N) Booster Pressure Tube	2.013 ± .020	0.067 ± .001	
KLO (S) " " "	2.031 ± .020	0.068 ± .001	
L1E (S) Calandria Surface	1.730 ± .017	0.048 ± .001	
MO (E) " " "	1.544 ± .015	0.036 ± .001	
JO	1.533 ± .015	0.035 ± .001	
J2E	1.448 ± .014	0.030 ± .001	(d)
L2E	1.434 ± .014	0.029 ± .001	
M1E	1.429 ± .014	0.029 ± .001	
NO	1.415 ± .014	0.028 ± .001	
O1E	1.377 ± .014	0.025 ± .001	
H0	1.448 ± .014	0.030 ± .001	
H0	1.201 ± .012	0.029 ± .002	
H0	1.435 ± .014	0.029 ± .001	
Thermal Pit (~E0)	1.000	0.396 × 10 ⁻³	

- (a) East side of fuel rod calandria surface at core location KO.
- (b) The reported activity ratios are ratios at the measurement position, relative to the same ratio at the thermal pit location. The $r\sqrt{T_n/T_o}$ value reported at the thermal pit was determined from a Cd ratio with In foils.
- (c) $T_o = T_{D_2O} = 21.16^\circ\text{C}$.
- (d) 0.5 cm wide Au and Cu strips.
- (e) 1.422 cm diameter Au-Al, Lu-Al, and Cu foil packages.
- (f) 0.775 cm diameter Au-Al, Lu-Al, and Cu foil packages.

TABLE D-3

MEASURED NEUTRON SPECTRUM PARAMETERS

CASE 30-32: 30.00 cm (D₂O) Hex Ref. Lattice
3, 33-element Boosters at LMO, JK2E, JK2W

Core Location		Au/Cu (b) Act. Ratio	$r\sqrt{T_n/T_o}$ (c)	Method
LMO: Booster pin sheath	1	1.638 ± .016	0.085 ± .003	(d)
	2	1.611 ± .016	0.081 ± .003	
	3	1.561 ± .016	0.075 ± .003	
	4	1.559 ± .016	0.075 ± .003	
	5	1.503 ± .015	0.067 ± .003	
	6	1.480 ± .015	0.064 ± .003	
KO: Fuel Pin	1	1.628 ± .016	0.042 ± .001	(e)
	2	1.692 ± .017	0.046 ± .001	
	3	1.727 ± .017	0.048 ± .001	
	4	1.728 ± .017	0.048 ± .001	
	5	1.701 ± .017	0.046 ± .001	
	6	1.646 ± .016	0.043 ± .001	
K0(S) (a) Calandria Surface		1.581 ± .016	0.038 ± .001	(f)
LMO(N) Booster Pressure Tube		2.069 ± .021	0.071 ± .001	
LMO(S) Booster Pressure Tube		1.980 ± .020	0.065 ± .001	
L1E(E) Calandria Surface		1.585 ± .016	0.039 ± .001	
L1E(W) Calandria Surface		1.749 ± .017	0.050 ± .001	
MO(W) Calandria Surface		1.705 ± .017	0.047 ± .001	
N1E(W) Calandria Surface		1.518 ± .015	0.034 ± .001	
JO		1.458 ± .015	0.030 ± .001	
K1E		1.475 ± .015	0.032 ± .001	
LO		1.674 ± .017	0.045 ± .001	
M1E		1.484 ± .015	0.032 ± .001	
NO		1.418 ± .014	0.028 ± .001	
O1E		1.388 ± .014	0.026 ± .001	
H0		1.410 ± .014	0.027 ± .001	
H0		1.191 ± .012	0.028 ± .001	
H0		1.430 ± .014	0.029 ± .002	
Thermal Pit (~E0)		1.000	0.386 × 10 ⁻³	

- (a) South side of fuel rod calandria surface at core location K0.
- (b) The reported activity ratios are ratios at the measurement position, relative to the same ratio at the thermal pit location. The $r\sqrt{T_n/T_o}$ value reported at the thermal pit was determined from a Cd ratio method with In foils.
- (c) $T_o = T_{D_2O} = 21.48^\circ\text{C}$
- (d) 0.5 cm wide Au and Cu strips.
- (e) 1.422 cm diameter Au-Al, Lu-Al and Cu foil packages.
- (f) 0.775 cm diameter Au-Al, Lu-Al and Cu foil packages.

TABLE D-4

MEASURED NEUTRON SPECTRUM PARAMETERS

CASE 30-42: 30.00 cm (D₂O) Hex Ref. Lattice
3,33-element Boosters at MNO, IJ3E, IJ3W

Core Location	Au/Cu ^(b) Act. Ratio	$r\sqrt{T_n/T_o}$ (c)	Method
MNO: Booster Pin Sheath 1	1.591 ± .016	0.079 ± .002	(d)
2	1.548 ± .015	0.073 ± .002	
3	1.507 ± .015	0.068 ± .002	
4	1.528 ± .015	0.070 ± .002	
5	1.458 ± .015	0.061 ± .002	
6	1.456 ± .015	0.061 ± .002	
N1E: Fuel Pin 1	1.853 ± .019	0.056 ± .001	(e)
2	1.902 ± .019	0.060 ± .001	
3	1.917 ± .019	0.061 ± .001	
4	1.859 ± .019	0.057 ± .001	
5	1.794 ± .018	0.052 ± .001	
6	1.693 ± .017	0.046 ± .001	
KO(E) (a) Calandria Surface	1.540 ± .016	0.037 ± .001	(f)
L1E (W) " "	1.522 ± .015	0.035 ± .001	
M2E (S) " "	1.517 ± .015	0.034 ± .001	
MO (E) " "	1.619 ± .016	0.041 ± .001	
N1E (N) " "	1.639 ± .016	0.042 ± .001	
OO (E) " "	1.501 ± .015	0.033 ± .001	
MNO (N) Booster Pressure Tube	2.018 ± .020	0.068 ± .001	
MNO (S) " " "	2.001 ± .020	0.066 ± .001	
J0	1.400 ± .014	0.027 ± .001	
J4E	1.503 ± .015	0.033 ± .001	
K3E	1.438 ± .014	0.029 ± .001	
L0	1.418 ± .014	0.028 ± .001	
L2E	1.437 ± .014	0.029 ± .001	
M1E	1.473 ± .015	0.031 ± .001	
O1E	1.390 ± .014	0.026 ± .001	
K1W	1.421 ± .014	0.028 ± .001	
K1W	1.186 ± .012	0.027 ± .001	(d)
K1W	1.400 ± .014	0.027 ± .001	(e)
Thermal Pit (~E0)	1.000	0.359 × 10 ⁻³	

- (a) East side of fuel rod calandria surface at core location KO.
- (b) The reported activity ratios are ratios at the measurement position, relative to the same ratio at the thermal pit location. The $r\sqrt{T_n/T_o}$ value reported at the thermal pit was determined from a Cd ratio method with In foils.
- (c) $T_o = T_{D_2O} = 21.58^\circ\text{C}$.
- (d) 0.5 cm wide Au and Cu strips.
- (e) 1.422 cm diameter Au-Al, Lu-Al, and Cu foil packages.
- (f) 0.775 cm diameter Au-Al, Lu-Al, and Cu foil packages.

TABLE D-5

MEASURED NEUTRON SPECTRUM PARAMETERS

CASE 30-44: 30.00 cm (D₂O) Hex Ref. Lattice
3,33-element Boosters at MNO, IJ4E, IJ4W

Core Location	Au/Cu ^(b) Act. Ratio	$r/\overline{T}_n/\overline{T}_O$ (c)	Method
KO (E) ^(a) Calandria Surface	1.542 ± .015	0.036 ± .001	(d)
L1E (W) " "	1.544 ± .015	0.036 ± .001	
MO (E) " "	1.649 ± .016	0.043 ± .001	
M2E (S) " "	1.551 ± .016	0.036 ± .001	
MNO (N) Booster Pressure Tube	2.031 ± .020	0.068 ± .001	
MNO (S) " " "	1.996 ± .020	0.066 ± .001	
N1E (N) Calandria Surface	1.659 ± .017	0.043 ± .001	
OO (E) " "	1.506 ± .015	0.033 ± .001	
J0	1.432 ± .014	0.028 ± .001	
K3E	1.447 ± .014	0.029 ± .001	
L0	1.446 ± .014	0.029 ± .001	
L2E	1.418 ± .014	0.028 ± .001	
M1E	1.491 ± .015	0.032 ± .001	
O1E	1.420 ± .014	0.028 ± .001	
Thermal Pit (~E0)	1.000	0.209 × 10 ⁻³	

- (a) East side of fuel rod calandria surface at core location KO.
- (b) The reported activity ratios are ratios at the measurement position, relative to the same ratio at the thermal pit location. The $r/\overline{T}_n/\overline{T}_O$ value reported at the thermal pit was determined from a Cd ratio method with In foils.
- (c) $T_O = T_{D_2O} = 20.09^\circ\text{C}$.
- (d) 0.775 cm diameter Au-Al, Lu-Al, and Cu foil packages.

TABLE D-6

MEASURED NEUTRON SPECTRUM PARAMETERS

CASE 30-50E: 30.00 cm (D₂O) Hex Ref. Lattice
Central 19 Rods Voided

Core Location	Au/Cu ^(b) Act. Ratio	$r\sqrt{T_n/T_o}$ (c)	Method
KO: Fuel Pin 1	1.633 ± .016	0.042 ± .001	(d)
2	1.697 ± .017	0.046 ± .001	
3	1.698 ± .017	0.046 ± .001	
4	1.716 ± .017	0.047 ± .001	
5	1.696 ± .016	0.046 ± .001	
6	1.646 ± .016	0.043 ± .001	
KO (S) (a) Calandria Surface	1.596 ± .016	0.039 ± .001	(e)
L1E (W) "	1.620 ± .016	0.041 ± .001	
MO (N) " "	1.615 ± .016	0.041 ± .001	
MO (S) " "	1.603 ± .016	0.040 ± .001	
N1E (W) " "	1.571 ± .016	0.038 ± .001	
JO	1.493 ± .015	0.033 ± .001	
K1E	1.482 ± .015	0.032 ± .001	
LO	1.484 ± .015	0.032 ± .001	
M1E	1.493 ± .015	0.033 ± .001	
NO	1.470 ± .015	0.031 ± .001	
O1E	1.409 ± .014	0.027 ± .001	(d)
HO	1.457 ± .015	0.030 ± .001	
HO	1.444 ± .014	0.029 ± .001	
HO	1.226 ± .012	0.032 ± .002	
Thermal Pit (~E0)	1.000	0.323 × 10 ⁻³	(f)

- (a) South side of fuel rod calandria surface at core location KO.
- (b) The reported activity ratios are ratios at the measurement position, relative to the same ratio at the thermal pit location. The $r\sqrt{T_n/T_o}$ value reported at the thermal pit was determined from a Cd ratio method with In foils.
- (c) $T_o = T_{D_2O} = 21.46^\circ\text{C}$.
- (d) 1.422 cm diameter Au-Al, Lu-Al, and Cu foil packages.
- (e) 0.775 cm diameter Au-Al, Lu-Al, and Cu foil packages.
- (f) 0.5 cm wide Au and Cu strips.

TABLE D-7

MEASURED NEUTRON SPECTRUM PARAMETERS

CASE 30-52D: 30.00 cm (D₂O) Hex Ref. Lattice
 Central 19 Rods Voided
 3,33-element Boosters at LMO, JK2E, JK2W

Core Location	Au/Cu ^(b) Act. Ratio	$r/T_n/T_o$ ^(c)	Method
LMO: Booster Pin Sheath 1	1.687 ± .017	0.091	(d)
2	1.686 ± .017	0.091	
3	1.626 ± .016	0.083	
4	1.652 ± .017	0.087	
5	1.537 ± .016	0.072	
6	1.545 ± .015	0.073	
KO: Fuel Pin 1	1.677 ± .017	0.045 ± .001	(e)
2	1.720 ± .017	0.048 ± .001	
3	1.744 ± .017	0.049 ± .001	
4	1.762 ± .018	0.050 ± .001	
5	1.741 ± .017	0.049 ± .001	
6	1.681 ± .017	0.045 ± .001	
KO(S) ^(a) Calandria Surface	1.637 ± .022	0.042 ± .001	(f)
LMO (N) Booster Pressure Tube	2.130 ± .028	0.075 ± .002	
LMO (S)	2.004 ± .028	0.075 ± .002	
LLE (E) Calandria Surface	1.653 ± .022	0.043 ± .001	
LLE (W)	1.781 ± .024	0.052 ± .002	
MO (W)	1.761 ± .023	0.050 ± .002	
NLE (W)	1.575 ± .021	0.039 ± .001	(d)
JO	1.477 ± .019	0.032 ± .001	
KLE	1.509 ± .020	0.034 ± .001	
LO	1.684 ± .022	0.045 ± .001	
MLE	1.539 ± .020	0.036 ± .001	
NO	1.435 ± .019	0.029 ± .001	
OLE	1.377 ± .018	0.025 ± .001	
HO	1.429 ± .019	0.028 ± .001	
HO	1.230 ± .012	0.033 ± .001	
HO	1.429 ± .014	0.028 ± .001	
HO	1.429 ± .014	0.028 ± .001	
Thermal Pit (~EO)	1.000	0.359 × 10 ⁻³	

- (a) South side of fuel rod calandria surface at core location KO.
- (b) The reported activity ratios are ratios at the measurement position, relative to the same ratio at the thermal pit location. The $r/T_n/T_o$ value reported at the thermal pit was determined from a Cd ratio method with In foils.
- (c) $T_o = T_{D_2O} = 21.35^\circ\text{C}$.
- (d) 0.5 cm wide Au and Cu strips.
- (e) 1.422 cm diameter Au-Al, Lu-Al, and Cu foil packages.
- (f) 0.775 cm diameter Au-Al, Lu-Al, and Cu foil packages.

TABLE D-8

MEASURED NEUTRON SPECTRUM PARAMETERS

CASE 30-65: 30.00 cm (D₂O) Hex Ref. Lattice
3,17-element Boosters at LMO, JK2E, JK2W

Core Location	Au/Cu ^(b) Act. Ratio	$r/T_n/T_o$ (c)	Method
LMO: Booster Pin Sheath 1	1.489 ± .015	0.065	(d)
2	1.456 ± .015	0.061	
3	1.411 ± .014	0.055	
4	1.419 ± .014	0.056	
KO: Fuel Pin 1	1.620 ± .016	0.041 ± .001	(e)
2	1.674 ± .017	0.044 ± .001	
3	1.714 ± .017	0.047 ± .001	
4	1.713 ± .017	0.047 ± .001	
5	1.689 ± .017	0.045 ± .001	
6	1.621 ± .016	0.041 ± .001	
KO (S) ^(a) Calandria Surface	1.570 ± .016	0.037 ± .001	(f)
L1E (E) " "	1.581 ± .016	0.038 ± .001	
L1E (W) " "	1.686 ± .017	0.045 ± .001	
LMO (N) Booster Pressure Tube	1.821 ± .018	0.054 ± .001	
LMO (S) " "	1.771 ± .018	0.051 ± .001	
MO (W) Calandria Surface	1.651 ± .017	0.043 ± .001	
N1E (W) " "	1.555 ± .016	0.036 ± .001	
JO	1.455 ± .015	0.030 ± .001	
K1E	1.479 ± .015	0.031 ± .001	
LO	1.596 ± .016	0.039 ± .001	
M1E	1.481 ± .015	0.032 ± .001	
NO	1.429 ± .014	0.028 ± .001	
O1E	1.392 ± .014	0.026 ± .001	
HO	1.420 ± .014	0.028 ± .001	
HO	1.193 ± .012	0.028 ± .001	(d)
HO	1.414 ± .014	0.027 ± .001	(e)
Thermal Pit (~EO)	1.000	0.236 × 10 ⁻³	

- (a) South side of fuel rod calandria surface at core location KO.
- (b) The reported activity ratios are ratios at the measurement position, relative to the same ratio at the thermal pit location. The $r/T_n/T_o$ value reported at the thermal pit was determined from a Cd ratio method with In foils.
- (c) $T_o = T_{D_2O} = 21.37^\circ\text{C}$.
- (d) 0.5 cm wide Au and Cu strips.
- (e) 1.422 cm diameter Au-Al, Lu-Al, and Cu foil packages.
- (f) 0.775 cm diameter Au-Al, Lu-Al, and Cu foil packages.

APPENDIX E

Comparison of Neutron Spectrum Detection Methods

TABLE E-1

COMPARISON OF VARIOUS SPECTRAL PARAMETER MEASUREMENT METHODS
LATTICE: 28.58 cm (D₂O Cooled) with 61-element 93% ²³⁵U Booster at R.O.

Measurement Method (a)	Booster Pin Sheath Ring Radius = 3.31 cm		JKIE Fuel Pin Inner Ring		JKIE Fuel Sheath Middle Ring		Booster Pressure Tube Surface		Calandria Surface JKIE		Thimbles						
	1	2	1	2	1	2	North	South	North	West	PIE	PIW	PIE	PIW	P4E	P4W	
1.422 cm Diameter In-La-Mn																	
1. In/Mn Act. Ratio	2.402 ± .024	2.372 ± .024	2.265 ± .023	2.181 ± .020	2.007 ± .026	2.125 ± .021	2.055 ± .021	2.056 ± .022	1.797 ± .018	1.794 ± .018	1.666 ± .017	1.633 ± .016	1.451 ± .014	1.435 ± .014	1.372 ± .014	1.382 ± .014	1.382 ± .014
2. r_{EP}/T_0	0.088 ± .002	0.086 ± .002	0.079 ± .001	0.073 ± .001	0.062 ± .001	0.069 ± .001	0.065 ± .001	0.064 ± .001	0.049 ± .001	0.048 ± .001	0.041 ± .001	0.039 ± .001	0.027 ± .002	0.026 ± .002	0.022 ± .001	0.023 ± .001	0.023 ± .001
3. Lu/Mn Act. Ratio	1.188 ± .012	1.181 ± .012	1.130 ± .013	1.289 ± .019	1.243 ± .012	1.076 ± .013	1.132 ± .011	1.130 ± .011	1.133 ± .011	1.108 ± .011	1.071 ± .011	1.059 ± .011	1.052 ± .011	1.052 ± .011	1.051 ± .011	1.047 ± .010	1.047 ± .010
4. T_0 (°C)	82 ± 6	80 ± 6	17 ± 6	112 ± 5	74 ± 5	100 ± 6	60 ± 5	59 ± 5	59 ± 4	53 ± 4	39 ± 4	39 ± 4	37 ± 3	37 ± 3	34 ± 3	32 ± 3	32 ± 3
1.422 cm Diameter Au-La-Cu																	
1. Au/Cu Act. Ratio	1.362 ± .019	1.322 ± .016	1.258 ± .018	1.258 ± .018	1.258 ± .018	1.258 ± .018	1.258 ± .018	1.258 ± .018	1.799 ± .017	1.777 ± .018	1.616 ± .014	1.625 ± .014	1.425 ± .014	1.425 ± .014	1.360 ± .014	1.360 ± .014	1.360 ± .014
2. r_{EP}/T_0	0.059 ± .001	0.059 ± .001	0.054 ± .001	0.049 ± .001	0.048 ± .001	0.048 ± .001	0.048 ± .001	0.048 ± .001	0.048 ± .001	0.048 ± .001	0.048 ± .001	0.048 ± .001	0.027 ± .001	0.028 ± .001	0.028 ± .001	0.028 ± .001	0.028 ± .001
3. Lu/Cu Act. Ratio	1.280 ± .019	1.293 ± .013	1.243 ± .012	1.243 ± .012	1.243 ± .012	1.243 ± .012	1.243 ± .012	1.243 ± .012	1.140 ± .011	1.135 ± .011	1.052 ± .011	1.052 ± .011	1.043 ± .010	1.052 ± .011	1.052 ± .011	1.052 ± .011	1.052 ± .011
4. T_0 (°C)	142 ± 5	105 ± 5	89 ± 5	89 ± 5	89 ± 5	89 ± 5	89 ± 5	89 ± 5	59 ± 4	58 ± 4	30 ± 3	30 ± 3	30 ± 3	30 ± 3	30 ± 3	30 ± 3	30 ± 3
0.775 cm Diameter Au-La-Cu																	
1. Au/Cu Act. Ratio	2.469 ± .024	2.419 ± .024	1.836 ± .018	1.879 ± .019	2.121 ± .021	2.108 ± .021	2.108 ± .021	2.108 ± .021	1.787 ± .018	1.769 ± .018	1.449 ± .014	1.443 ± .014	1.443 ± .014	1.443 ± .014	1.443 ± .014	1.443 ± .014	1.443 ± .014
2. r_{EP}/T_0	0.094 ± .002	0.094 ± .002	0.055 ± .001	0.057 ± .001	0.074 ± .001	0.073 ± .001	0.073 ± .001	0.073 ± .001	0.050 ± .001	0.050 ± .001	0.029 ± .001	0.029 ± .001	0.029 ± .001	0.029 ± .001	0.029 ± .001	0.029 ± .001	0.029 ± .001
3. Lu/Cu Act. Ratio	1.087 ± .012	1.192 ± .012	1.283 ± .012	1.276 ± .013	1.154 ± .012	1.125 ± .011	1.125 ± .011	1.125 ± .011	1.157 ± .012	1.145 ± .011	1.062 ± .011	1.062 ± .011	1.062 ± .011	1.062 ± .011	1.062 ± .011	1.062 ± .011	1.062 ± .011
4. T_0 (°C)	80 ± 6	82 ± 6	74 ± 5	101 ± 5	68 ± 5	56 ± 5	56 ± 5	56 ± 5	64 ± 4	59 ± 4	36 ± 3	36 ± 3	36 ± 3	36 ± 3	36 ± 3	36 ± 3	36 ± 3
1.422 cm Diameter Au-La-Cu																	
1. Au/Cu Act. Ratio	2.388 ± .024	2.394 ± .024	1.886 ± .019	1.812 ± .018	1.741 ± .019	1.848 ± .018	1.895 ± .021	1.872 ± .021	1.736 ± .017	1.740 ± .017	1.649 ± .016	1.641 ± .016	1.418 ± .014	1.414 ± .014	1.360 ± .014	1.360 ± .014	1.360 ± .014
2. r_{EP}/T_0	0.092 ± .002	0.093 ± .002	0.058 ± .001	0.053 ± .001	0.048 ± .001	0.056 ± .001	0.072 ± .001	0.071 ± .001	0.048 ± .001	0.048 ± .001	0.042 ± .001	0.042 ± .001	0.027 ± .001	0.027 ± .001	0.027 ± .001	0.027 ± .001	0.027 ± .001
3. Lu/Cu Act. Ratio	2.436 ± .024	2.447 ± .025	1.768 ± .018	1.907 ± .019	2.149 ± .021	2.121 ± .021	2.121 ± .021	2.121 ± .021	1.773 ± .018	1.768 ± .018	1.498 ± .012	1.455 ± .017	1.430 ± .014	1.435 ± .014	1.397 ± .014	1.394 ± .014	1.394 ± .014
4. T_0 (°C)	0.094 ± .002	0.096 ± .002	0.050 ± .001	0.060 ± .001	0.076 ± .001	0.074 ± .001	0.074 ± .001	0.074 ± .001	0.051 ± .001	0.050 ± .001	0.046 ± .001	0.043 ± .001	0.029 ± .001	0.029 ± .001	0.029 ± .001	0.029 ± .001	0.029 ± .001
Mean of Au-La-Cu Methods																	
1. Au/Cu Act. Ratio	2.401 ± .012	2.420 ± .012	1.891 ± .010	1.817 ± .010	1.776 ± .010	1.868 ± .010	1.921 ± .010	1.899 ± .010	1.750 ± .010	1.764 ± .010	1.674 ± .010	1.648 ± .010	1.430 ± .010	1.431 ± .010	1.369 ± .010	1.373 ± .010	1.373 ± .010
2. r_{EP}/T_0	0.093 ± .001	0.094 ± .001	0.059 ± .001	0.051 ± .001	0.051 ± .001	0.057 ± .001	0.074 ± .001	0.073 ± .001	0.050 ± .001	0.050 ± .001	0.049 ± .001	0.049 ± .001	0.028 ± .001	0.028 ± .001	0.028 ± .001	0.028 ± .001	0.028 ± .001
3. Lu/Cu Act. Ratio	1.187 ± .010	1.192 ± .010	1.280 ± .010	1.293 ± .010	1.243 ± .010	1.259 ± .010	1.143 ± .010	1.129 ± .010	1.149 ± .010	1.138 ± .010	1.094 ± .010	1.043 ± .010	1.051 ± .010	1.052 ± .010	1.052 ± .010	1.052 ± .010	1.052 ± .010
4. T_0 (°C)	80 ± 4	82 ± 4	102 ± 4	105 ± 4	70 ± 4	95 ± 4	62 ± 4	57 ± 4	62 ± 3	59 ± 3	33 ± 3	33 ± 3	33 ± 3	33 ± 3	33 ± 3	33 ± 3	33 ± 3
0.5 cm wide Au-La Straps Normalized to Mean In-La-Cu Methods																	
1. Au/Cu Act. Ratio	1.719 ± .017	1.685 ± .017	1.594 ± .014	1.428 ± .014	1.558 ± .016	1.429 ± .015	1.371 ± .014	1.387 ± .014	1.390 ± .014	1.325 ± .014	1.220 ± .012	1.220 ± .012	1.210 ± .012	1.210 ± .012	1.189 ± .012	1.192 ± .012	1.192 ± .012
2. r_{EP}/T_0	0.095 ± .002	0.090 ± .002	0.051 ± .002	0.056 ± .002	0.074 ± .002	0.070 ± .002	0.050 ± .002	0.052 ± .002	0.047 ± .002	0.044 ± .002	0.031 ± .002	0.031 ± .002	0.031 ± .002	0.031 ± .002	0.027 ± .002	0.027 ± .002	0.027 ± .002
Ratio of results: Mean Au-La-Cu to In-La-Cu																	
1. r_{EP}/T_0	1.057	1.093	0.947	0.740	0.823	0.826	1.138	1.123	1.020	1.042	1.073	1.103	1.037	1.077	1.091	1.087	1.087
2. T_0 Ratio	0.976	1.025	0.872	0.938	0.957	0.950	1.033	0.966	1.069	1.157							

(a) The reported activity ratios are ratios at the measurement position, relative to the same ratio at the thermal pit location. At the thermal pit location, $r_{EP}/T_0 = 0.137 \times 10^{-3}$ was determined by a Cd ratio method with 16 foils.

(b) $T_0 = T_{D2O} = 28.9600$.

TABLE E-2

$r\sqrt{T_n/T_o}$ VALUES - In/Mn CONVERTED TO Au/Cu
CASE 28-10: 28.58 cm (D.O) REFERENCE LATTICE

Detector ^(a) Location	Measurement Position (cm)	Position Measured From	Direction	$r\sqrt{T_n/T_o}$ From In/Mn Ratio	$r\sqrt{T_n/T_o}$ (b) Converted to Au/Cu
Mod. Cal. S. Fuel	0.02	Lattice Center	NW	0.022 + .001	0.024 + .002
	6.84	Lattice Center	SE	0.025 + .001	0.027 + .002
	13.84			0.032 + .001	0.034 + .002
	16.00			0.043 + .001	0.038 + .002
	17.56			0.053 + .001	0.042 + .002
	19.05			0.056 + .001	0.042 + .002
	21.37			0.058 + .001	0.043 + .002
	22.86			0.052 + .001	0.041 + .002
	24.42			0.044 + .001	0.039 + .002
	26.58			0.031 + .001	0.033 + .002
Cal. S. Mod.	33.53			0.023 + .001	0.025 + .002
	40.48			0.021 + .001	0.023 + .002
Mod. Cal. S.	9.99	Lattice Center	E	0.024 + .001	0.026 + .002
	6.37	Center of Rod JK1E	N	0.032 + .001	0.034 + .002
Mod. Cal. S. Mod. Cal. S. Mod.	10.52			0.026 + .001	0.028 + .002
	14.47			0.026 + .001	0.028 + .002
	6.37	Center of Rod JK1E	S	0.032 + .001	0.034 + .002
	10.57			0.026 + .001	0.028 + .002
	14.29			0.025 + .001	0.027 + .002

(a) See foot notes Table 2.

(b) $(r\sqrt{T_n/T_o})$ In/Mn converted to $(r\sqrt{T_n/T_o})$ Au/Cu by extrapolation of results in Table E-1.