

CONF-9609325--1



**ERNEST ORLANDO LAWRENCE
BERKELEY NATIONAL LABORATORY**

**Electrochromic Lithium
Nickel Oxide by Pulsed Laser
Deposition and Sputtering**

RECEIVED

FEB 26 1997

OSTI

M. Rubin, S-J. Wen, T. Richardson, J. Kerr,
K. von Rottkay, and J. Slack

Energy and Environment Division

September 1996
Presented at the
*SPIE International
Symposium on Optical
Materials Technology
for Energy Efficiency
and Solar Energy
Conversion XV,*
Freiburg, Germany,
September 16-19 1996,
and to be published in
the Proceedings

MASTER

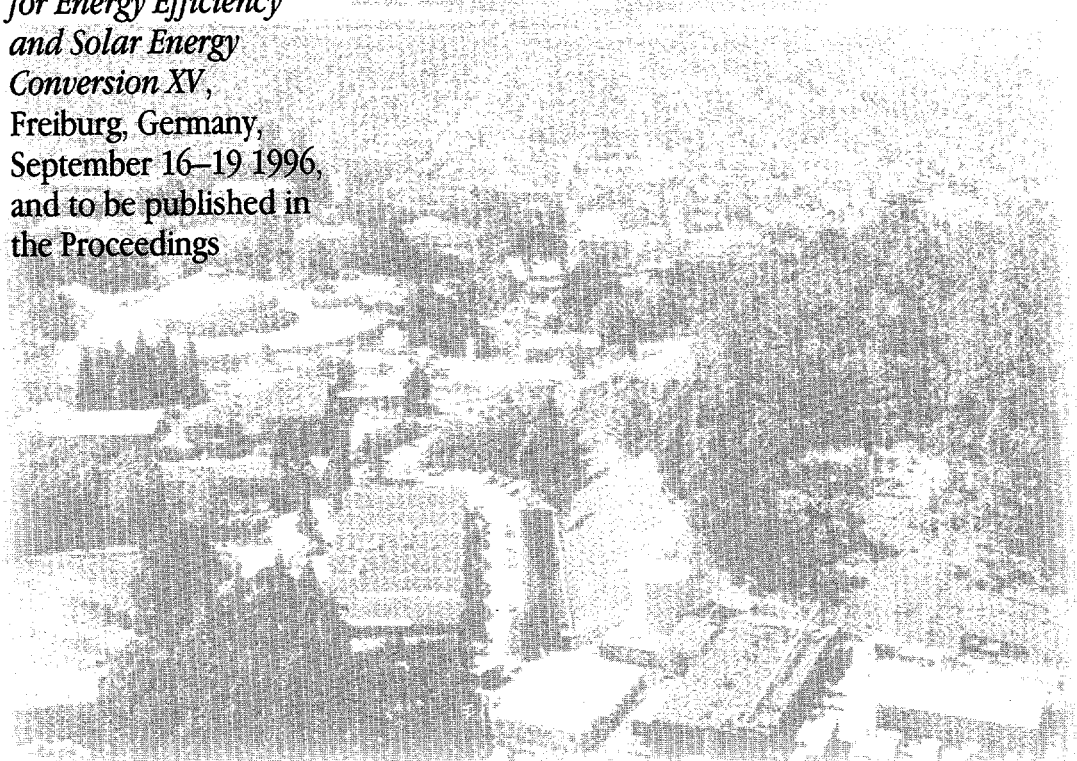

DISTRIBUTION OF THIS DOCUMENT IS UNLIMITED

J

DISCLAIMER

This document was prepared as an account of work sponsored by the United States Government. While this document is believed to contain correct information, neither the United States Government nor any agency thereof, nor The Regents of the University of California, nor any of their employees, makes any warranty, express or implied, or assumes any legal responsibility for the accuracy, completeness, or usefulness of any information, apparatus, product, or process disclosed, or represents that its use would not infringe privately owned rights. Reference herein to any specific commercial product, process, or service by its trade name, trademark, manufacturer, or otherwise, does not necessarily constitute or imply its endorsement, recommendation, or favoring by the United States Government or any agency thereof, or The Regents of the University of California. The views and opinions of authors expressed herein do not necessarily state or reflect those of the United States Government or any agency thereof, or The Regents of the University of California.

Ernest Orlando Lawrence Berkeley National Laboratory
is an equal opportunity employer.

Presented at SPIE's International Symposium on Optical Materials Technology for Energy Efficiency and Solar Energy Conversion XV, Freiburg, Germany (September 1996) and to be published in the proceedings.

Electrochromic Lithium Nickel Oxide by Pulsed Laser Deposition and Sputtering

M. Rubin, S-J. Wen, T. Richardson, J. Kerr, K. von Rottkay, and J. Slack

Building Technologies Program
Energy and Environment Division
Lawrence Berkeley National Laboratory
University of California
Berkeley, CA 94720

September 1996

This work was supported by the Assistant Secretary for Energy Efficiency and Renewable Energy, Office of Building Technology, State and Community Programs (BTS), Office of Building Systems of the U.S. Department of Energy under Contract No. DE-AC03-76SF00098.

DISCLAIMER

**Portions of this document may be illegible
in electronic image products. Images are
produced from the best available original
document.**

Electrochromic Lithium Nickel Oxide by Pulsed Laser Deposition and Sputtering

M. Rubin, S-J. Wen, T. Richardson, J. Kerr, K. von Rottkay, J. Slack

Lawrence Berkeley National Laboratory
University of California, Berkeley, CA 94720 USA
Tel: 510 486 7124, Fax: 510 486 6099, E-Mail: MDRubin@lbl.gov.

ABSTRACT

Thin films of lithium nickel oxide were deposited by sputtering and pulsed laser deposition (PLD) from targets of pressed LiNiO_2 powder. The composition and structure of these films were analyzed using a variety of techniques, such as nuclear-reaction analysis, Rutherford backscattering spectrometry (RBS), x-ray diffraction, infrared spectroscopy, and atomic force microscopy. Crystalline structure, surface morphology and chemical composition of $\text{Li}_x\text{Ni}_{1-x}\text{O}$ thin films depend strongly on deposition oxygen pressure, temperature as well as substrate-target distance. The films produced at temperatures lower than 600 °C spontaneously absorb CO_2 and H_2O at their surface once they are exposed to the air. The films deposited at 600 °C proved to be stable in air over a long period. Even at room temperature the PLD films are denser and more stable than sputtered films. RBS determined the composition of the best films to be $\text{Li}_{0.5}\text{Ni}_{0.5}\text{O}$ deposited by PLD at 60 mTorr O_2 pressure. Electrochemical tests show that the films exhibit excellent reversibility in the range 1.0 V to 3.4 V versus lithium. Electrochemical formatting which is used to develop electrochromism in other films is not needed for the stoichiometric films. The optical transmission range is almost 70% at 550 nm for 150-nm thick films. Devices made from these films were analyzed using novel reference electrodes and by disassembly after cycling.

1. INTRODUCTION

The layered form of lithium nickel oxide LiNiO_2 is used as a battery electrode while the cubic form of lithium nickel oxide written as $\text{Li}_x\text{Ni}_{1-x}\text{O}$ may have promising electrochromic performance. $\text{Li}_x\text{Ni}_{1-x}\text{O}$ can have a wide optical range and more neutral color than tungsten oxide as well as better stability. Furthermore $\text{Li}_x\text{Ni}_{1-x}\text{O}$ is anodically coloring so it has the advantage of being complementary to cathodic tungsten oxide. The main disadvantage of $\text{Li}_x\text{Ni}_{1-x}\text{O}$ is that it is difficult to deposit in the desired composition and phase.

The best results were obtained by pulsed laser deposition (PLD) which has not often been used to deposit electrochromic films. The PLD technique is not well suited for large-area deposition, but it has a number of practical advantages for laboratory development of new materials: speed, small easily fabricated targets, tendency to preserve composition. These factors allow us to generate new materials very quickly. When optimum conditions have been established using PLD, it is then usually possible to duplicate the film by sputtering.

In this paper, we describe our method to deposit films of the desired properties by PLD. We then describe the optimized electrochemical and optical properties of optimized films. Finally, some novel aspects of analysis on devices incorporating these materials are demonstrated.

2. METHODS

Starting from hexagonal layered-structure LiNiO_2 powder targets were isostatically pressed and sintered at a temperature $T = 700\text{ }^\circ\text{C}$ for 48 hours under pure oxygen flow to a final density of $\rho = 4.3\text{ g/cm}^3$. After sintering, the target was analyzed by XRD; It retains the same layered structure as that of starting powder. Unsintered targets produced the same types of films, but the targets were more fragile and difficult to handle. Other targets were made starting with Li_2O and NiO powders or longer higher-temperature sintering. These targets had the cubic NaCl structure and a higher density of 5.4 g/cm^3 . The resultant films, again were very similar. So, for the best balance of mechanical strength and ease of processing we used the targets sintered at the lower temperature.

For all the films made by PLD, the deposition conditions are the same except the oxygen pressure. The KrF excimer laser was operated at 10 pulses/sec, and 600 mJ per pulse for 8 minutes. The substrate was not heated and remained near room temperature and the distance between target and substrate was 7 cm. The base pressure was 1×10^{-6} Torr and the oxygen pressure varied from 20 to 200 mTorr. The best r.f. sputtered films were made at 30 mTorr total pressure with a mixture of 80% Ar and 20% O₂ in a cryopumped chamber with a base pressure of 1.3×10^{-7} Torr. The source-to-substrate distance was about 6 cm.

Primary optical measurements were made with a variable-angle spectroscopic ellipsometer (VASE) from 250 nm to 1000 nm using an instrument from the J.A. Woollam Co. In order to cover the whole solar spectrum, transmittance and reflectance measurements from 250 nm to 2500 nm were added; these measurements were taken at near-normal incidence on a Perkin-Elmer Lambda 19 spectrophotometer.

Rutherford Backscattering Spectrometry (RBS) and Nuclear Reaction Analysis (NRA) was used to determine the film composition. Ellipsometry was used not only as part of the optical analysis but also to measure film thickness. Other types of structural analysis were performed with x-ray diffraction (XRD), infrared spectroscopy and atomic force microscopy (AFM).

Devices were constructed primarily as test packages for the Li_xNi_{1-x}O material using otherwise well known components. The opposite electrode was sputtered WO₃. The solid polymer electrolyte is a capped amorphous PEO/LiTFSI layer with a thickness of 200-250 microns. The devices, however, were noteworthy for their incorporation of integrated reference electrodes to allow monitoring of internal device potentials. A small area of either electrode and transparent conductor, located at the corner of the device, was isolated electrically from the active area by scribing the film. This isolated electrode serves as a pseudoreference because it remains in contact with the same electrolyte layer as the active electrodes. The area of the reference is approximately $0.1 \times 0.1 \text{ cm}^2$ while the active area of the device is a much larger $2 \times 2 \text{ cm}^2$. The isolation gaps are typically 150-200 microns; on the order of the thickness of the polymer. We are working on improving our patterning so that the width of the reference is also on the order of the electrolyte thickness. This would ensure that the electrochemical state of the electrolyte everywhere opposite the reference electrodes is similar to that of the electrolyte opposite the active area.

Electrochemical measurements were performed with an Arbin multichannel potentiostat/galvanostat. This instrument was configured with an auxiliary input/output for each channel to allow for the recording of optical transmittance data. Measurements on films were made inside a dry box at less than 1 ppm of O₂. For standard two-terminal devices, one channel with two output/input connections was used to control the experiments, either by fixing the applied voltage between the two electrodes ($V_1 - V_2$) or by controlling $V_1 - V_2$ using optical transmission feedback. For devices with built-in reference electrodes (see below), two additional channels were used to simultaneously record the voltage signals $V_3 - V_1$, $V_3 - V_2$, $V_4 - V_2$ and $V_4 - V_1$ between the four electrodes.

Some devices were cut apart and the polymers are dissolved off with methylene chloride. We also place the films in water to hydrolyze any insoluble salts and then extract any products into methylene chloride. Usually we then combine the methylene chloride extracts for analysis by gas chromatography. We can keep the aqueous extracts separate from the non-aqueous polymer solutions to see if there are differences due to insoluble layers on the films.

3. RESULTS

Most of our films for making devices were deposited at room temperature by either PLD or sputtering. All such films were found to be amorphous by x-ray diffraction (XRD). Nevertheless, we can get some local structural information from XRD on films deposited at higher temperatures and then comparing to supplementary FTIR data at both high and low temperatures. XRD of PLD films deposited at 400 C° or 600 C° shows a cubic structure corresponding to Li_xNi_{1-x}O. FTIR spectra of PLD films deposited at room temperature have the same Ni-O (or Li-O) absorption bands as those of the PLD film deposited at elevated temperatures of 400 C° or 600 C°. The low-temperature films, however, are sensitive to the atmosphere, showing absorption bands of H₂O and CO₂ not present in the high-temperature films. This phenomenon is very similar to the case of NiO.^{1,2} The films deposited at 600 C° proved to be stable in air over a long period. FTIR spectra of room-temperature sputtered films with different composition show similar absorption bands as those of PLD films but slightly shifted. Sputtered films also show surface sensitivity to the air but with higher activity. The greatly different composition of the sputtered films and appearance of a double peak possibly indicate the formation of a second phase.

Higher particle energies associated with lower O₂ pressures might be expected to damage and roughen the surface or perhaps the opposite trend could occur and the higher energies would increase surface mobility to produce smoother films. We observe that Li_xNi_{1-x}O films deposited by PLD are generally quite smooth with lower O₂ pressures resulting in the smoothest films (see Figure 1). The same trend is also observed in a number of other lithium metal oxides.³ As discussed below, the exceptionally smooth film of Figure 1a deposited at 60 mTorr is far better in its electrochromic properties than the rougher film deposited at 200 mTorr. This result runs counter to the frequent supposition that rougher, more open films will intercalate charge more readily.

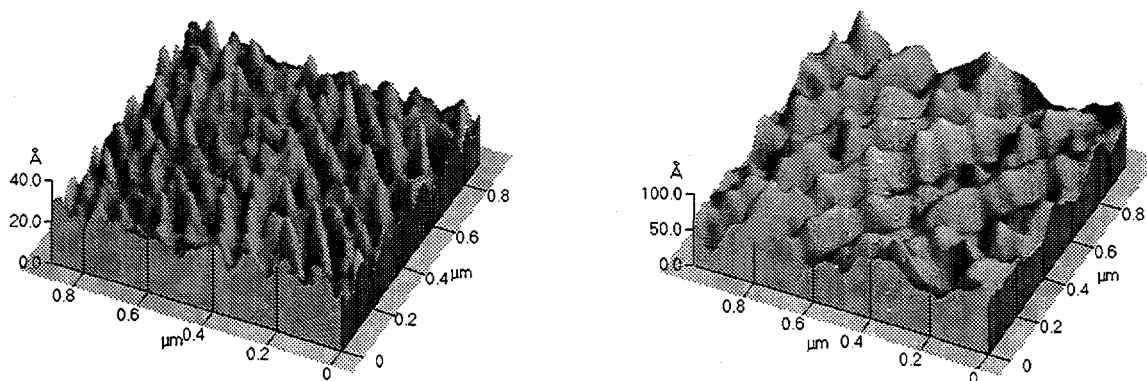

Figure 1. Surface of Li_xNi_{1-x}O at a) 60 mTorr oxygen pressure with rms roughness 4 Å and b) 200 mTorr oxygen pressure with rms roughness 14 Å

The deposition rate or film thickness increases linearly over the entire range of deposition O₂ pressure (Figure 2a). This effect is somewhat surprising because increasing chamber pressure in this regime often slows the deposition rate strongly due to increasing collision cross sections. The ejected particles in the plume, consisting predominately of atomic species, may be limited from reacting on the surface by the availability of oxygen. The Li/Ni and Li/O ratios also increase with O₂ pressure as shown in Figure 1a and Figure 2b. The stoichiometric composition Li_{0.5}Ni_{0.5}O is achieved at a pressure of 60 mTorr. As we shall see below, this composition corresponds to the best electrochromic properties. At pressures higher than 60 mTorr, the formation of an unidentified second phase is observed by XRD. Sputtered films deposited over a similar range of pressure tend to have a much lower lithium content as deposited.

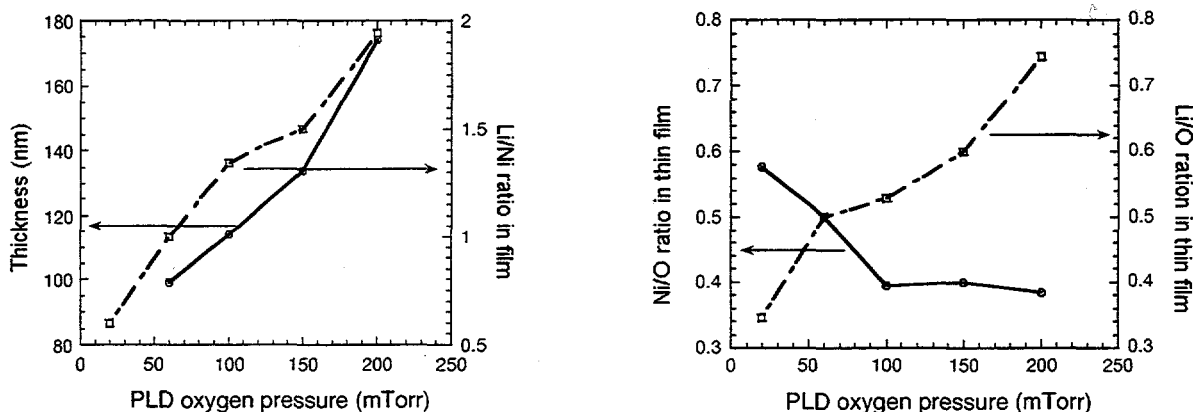

Figure 2: Film composition and deposition rate as function of O₂ PLD deposition pressure: a) thickness and Li/Ni ratio; and b) Li/O and Ni/O ratios.

Nickel oxide thin films deposited by sputtering are face-centered cubic with the NaCl structure near the stoichiometric composition NiO. Electrochemical cycling was found to result in an irreversible uptake of lithium on vacant nickel sites.⁴ A transparent compound of the type Li_yNiO_x is formed. This stable lithium compound then can reversibly intercalate a further quantity of lithium accompanied by an electrochromic coloration effect. It was later observed that superior films could be obtained by directly incorporating Li into the film structure during the sputter deposition.⁵ Such films required less formatting, had a wider optical range and better stability. Those films, however, were still not fully stoichiometric $\text{Li}_{0.5}\text{Ni}_{0.5}\text{O}$ as deposited.

Cyclic voltammograms were obtained from fresh PLD and sputtered LiNiO films. The films were cycled in 1M LiPF_6 in 1:1 ethylene carbonate/propylene carbonate over the range 1.0 to 4.5 V vs. Li/Li^+ using lithium foil counter and reference electrodes. While the initial open circuit potentials of the two films were nearly the same, their electrochemical behavior was quite different. The stoichiometric $\text{Li}_{0.5}\text{Ni}_{0.5}\text{O}$ PLD film (Figure 3a) was very stable over eight cycles and achieved its full optical range on the first cycle. Both the optical and electrochemical behavior are very similar to that achieved with slightly substoichiometric sputtered films after 123 cycles.⁵ We also tested a sputtered film that was far from stoichiometric composition at $\text{Li}_{0.09}\text{Ni}_{0.25}\text{O}_{0.66}$ (Figure 3b). The behavior of this sputtered film strongly resembles that of Li_xNiO_2 powder⁶. The optical range is much narrower and unstable. It shows the bimodal transmittance characteristic discovered by Passerini and Scrosati⁷ for formatted NiO films, i.e., the transmittance eventually turns down as more charge is injected. After a full cycle the transmittance recovers its maximum level. In a separate study, we determined the optical indices of $\text{Li}_{0.5}\text{Ni}_{0.5}\text{O}$ over the entire solar spectrum in a range of electrochromic states.³

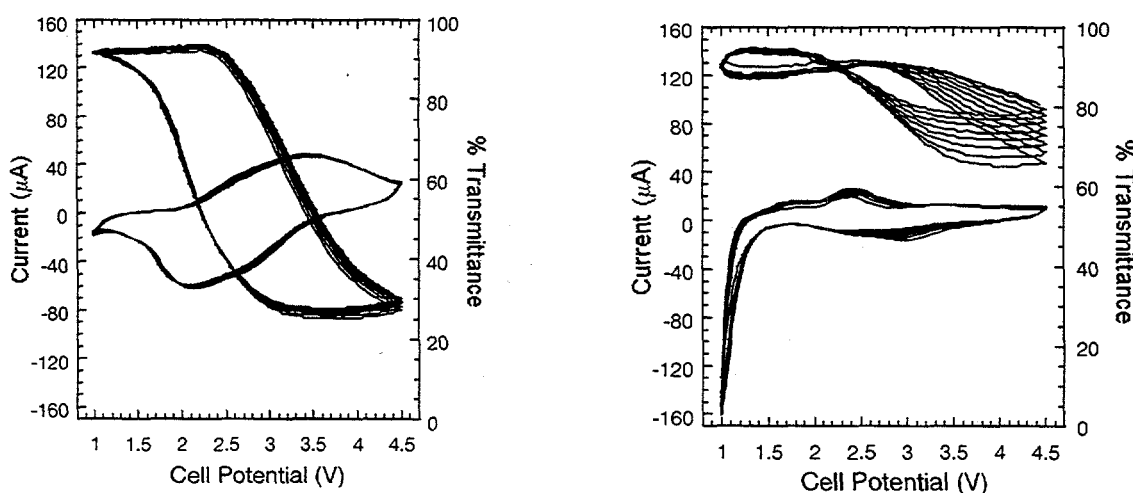

Figure 3. Cyclic voltammograms and transmittance/voltage of: a) PLD $\text{Li}_{0.5}\text{Ni}_{0.5}\text{O}$ and b) sputtered $\text{Li}_x\text{Ni}_{1-x}\text{O}$.

In situ diagnostics of devices built to test these electrodes is greatly aided by the use of devices containing a reference or pseudo-reference electrode (as described in Methods). In a 2-terminal device only the voltage applied across the full device is known. The time-dependent voltages that develop within the device are unknown unless the potentials of the various components can somehow be accessed. Two devices were tested under conditions that resulted in significant degradation of electrochemical and optical properties over thousands of cycles. Deterioration occurs in both bleach/coloration capacity as well as optical transmission. Devices A and B both contain WO_3 and $\text{Li}_x\text{Ni}_{1-x}\text{O}$ electrodes, but in device B the WO_3 layer is thicker and is made under optimal conditions. For device A, coloration capacity is always slightly larger than bleach capacity while the reverse is true for device B. Figure 4a shows that for device A, the polarization (V4-V2) at the WO_3 /polymer interface increased with cycling while V4-V1 decreased. For device B in Figure 4b, the opposite trend occurred, i.e. V4-V1 increased with cycling and V4-V2 stayed roughly constant. So, in this case, polarization was increasing at the $\text{Li}_x\text{Ni}_{1-x}\text{O}$ interface. Some recovery of devices was later possible using feedback control methods.

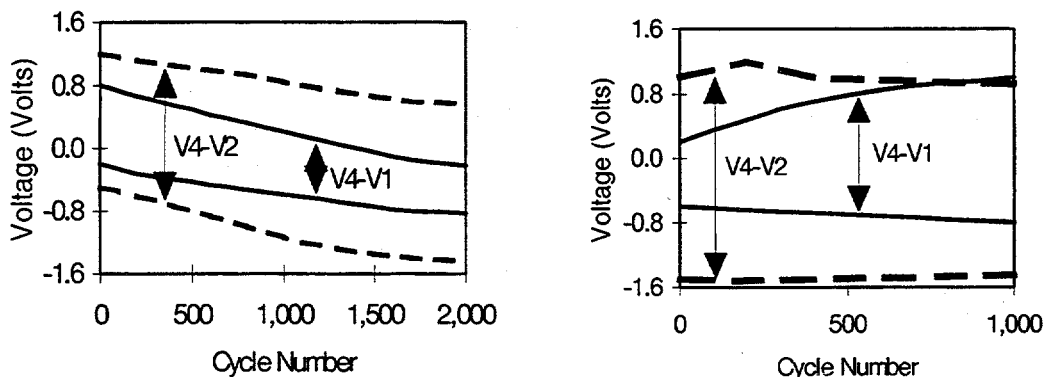

Figure 4. Cycling of devices with reference electrodes: a) device A; b) device B

After examination of the internal potentials during cycling, the devices can be dismantled to see, among other things, what has happened to the polymer. The purpose of the methylene link in amorphous PEO polymer is to disrupt the symmetry of the polymer structure and thereby prevent the formation of crystals which impede conductivity. The oxymethylene link, however, may be more vulnerable to cleavage due to UV light or oxidation. One therefore might expect to see a product distribution from degradation that reflects the suspected weakness of this structure.

Figure 5a. shows the chromatogram of capped PEO/LiTFSI with building blocks of 8 or 9 ethylene oxide units taken from a $\text{WO}_3/\text{Li}_x\text{Ni}_{1-x}\text{O}$ device after cycling. The largest ethylene oxide product is E_8 which is $\text{MeO}-(\text{CH}_2\text{CH}_2\text{O})_8\text{H}$ with a molecular weight of 368 and E_9 with a molecular weight of 412. The product distribution observed here does reflect a breakage at the oxymethylene linkage. However, the amount of E_3 formed is anomalous. This device was made with reference electrodes and showed an increasing resistance at the WO_3 interface as described above. A symmetric device with matching $\text{Li}_x\text{Ni}_{1-x}\text{O}$ electrodes was tested to eliminate the effect of the WO_3 . In this case, the results are very similar to the previous asymmetric device, but E_3 is now of the same magnitude as the surrounding peaks (Figure 5b). The increased level of E_3 may therefore result from an interaction with the WO_3 . Analysis of a cycled symmetrical WO_3 device would now be interesting, but the first devices of this type failed early in testing.

A polymer made with building blocks of 5 ethylene oxide units, rather than 8 units, as in the first two examples, was used for the next device experiment. The chromatogram of this device was taken after only a few initial cycles followed by storage at room temperature for six months. shows high incidence of E_1 and E_2 , less strong E_3 , E_4 and E_5 peaks, and essentially nothing above E_5 except for small fragments which resulted from coblanding. This is practically the reverse trend from the previous cases. The polymer is clearly being broken down thermally and in a very different way from the cycled devices.

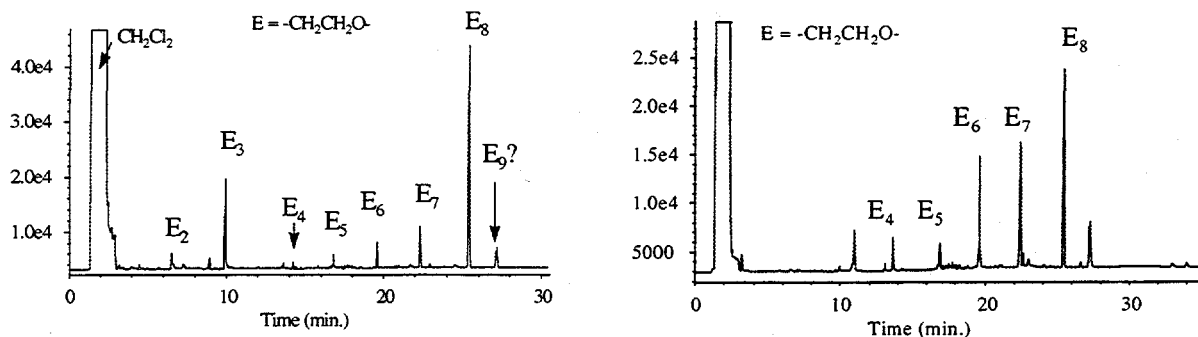

Figure 5. Gas Chromatograms of CH_2Cl_2 extracts from two cycled devices: a) $\text{LiNiO}_x/\text{caPEO-LiTFSI}/\text{WO}_3$ and b) $\text{LiNiO}_x/\text{caPEO-LiTFSI}/\text{NiO}_x$ cycled symmetrical device.

4. CONCLUSIONS

PLD is a highly useful technique to produce thin film $\text{Li}_{0.5}\text{Ni}_{0.5}\text{O}$ with optimal electrochromic properties. Modification of sputtering conditions or target stoichiometry should enable us to produce similar films by conventional large-area deposition. Films having the stoichiometric composition switch over a wide optical range, in the class of primary coloring electrodes like WO_3 , without the need for initial electrochemical formatting. The films seem also to have good long-term stability. A novel technique for incorporating reference electrodes into thin-film devices helped us to identify interfacial problems that at least were not consistently due to the $\text{Li}_x\text{Ni}_{1-x}\text{O}$ electrode. Destructive analysis of the polymer electrolytes also indicated problems that point more to the WO_3 electrode as the source of polymer degradation.

5. ACKNOWLEDGMENT

This work was supported by the Assistant Secretary for Energy Efficiency and Renewable Energy, Office of Building Technology, State and Community Programs (BTS), Office of Building Systems of the U.S. Department of Energy under Contract No. DE-AC03-76SF00098.

6. REFERENCES

- ¹ Courtois set S.J. Teichner, *J. Catal.*, **1** (1962) 121.
- ² Nakamoto, *Infrared and Raman Spectra of Inorganic and Coordination Compounds*, third edition, New York, Wiley (1978), pp. 243.
- ³ M. Rubin, K. von Rottkay, S.-J. Wen, N. Ozer, and J. Slack, presented at the Int. Symp on Opt. Mater. Technol. (Freiburg, Germany, Sept 1996) and published in Proc. SPIE.
- ⁴ F. Decker, S. Passerini, R. Pileggi, and B. Scrosati, *Electrochimica Acta* **37** (1992) 1033.
- ⁵ J.-C. Giron, Ph.D. Thesis, l'Universite Paris (1994).
- ⁶ M. Broussely, F. Perton, J. Labat, R. J. Staniewicz and A Romero, *J. Power Sources*, **43-44**, 217 (1993).
- ⁷ S. Passerini and B. Scrosati, *Solid State Ionics*, **53-56** (1992) 520.