

CONF-9611138--1

BNL - 63864  
CAP-156-MUON-96C



# HIGH LUMINOSITY $\mu + \mu^-$ COLLIDER: REPORT OF A FEASIBILITY STUDY

Robert B. Palmer, Juan C. Gallardo

*Brookhaven National Laboratory  
Upton, New York, 11973, U.S.A.*

Alvin Tollestrup

*Fermi National Accelerator Laboratory  
Batavia, IL, 60510, U.S.A.*

Andrew Sessler

*Lawrence Berkeley National Laboratory  
Berkeley, CA, 94720, U.S.A.*

RECEIVED  
FEB 06 1997  
O.S.I.

December 1996

**CENTER FOR ACCELERATOR PHYSICS**

**MASTER**

DISTRIBUTION OF THIS DOCUMENT IS UNLIMITED

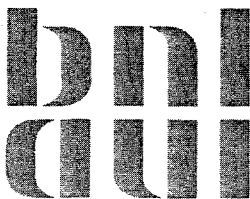

**BROOKHAVEN NATIONAL LABORATORY  
ASSOCIATED UNIVERSITIES, INC.**

Under Contract No. DE-AC02-76CH00016 with the

**UNITED STATES DEPARTMENT OF ENERGY**

#### DISCLAIMER

This report was prepared as an account of work sponsored by an agency of the United States Government. Neither the United States Government nor any agency thereof, nor any of their employees, nor any of their contractors, subcontractors, or their employees, makes any warranty, express or implied, or assumes any legal liability or responsibility for the accuracy, completeness, or usefulness of any information, apparatus, product, or process disclosed, or represents that its use would not infringe privately owned rights. Reference herein to any specific commercial product, process, or service by trade name, trademark, manufacturer, or otherwise, does not necessarily constitute or imply its endorsement, recommendation, or favoring by the United States Government or any agency, contractor or subcontractor thereof. The views and opinions of authors expressed herein do not necessarily state or reflect those of the United States Government or any agency, contractor or subcontractor thereof.

**DISCLAIMER**

**Portions of this document may be illegible in electronic image products. Images are produced from the best available original document.**

# HIGH LUMINOSITY $\mu^+\mu^-$ COLLIDER: REPORT OF A FEASIBILITY STUDY

ROBERT B. PALMER, JUAN C. GALLARDO  
*Brookhaven National Laboratory, Upton, NY 11973*

ALVIN TOLLESTRUP  
*Fermi National Accelerator Laboratory, Batavia, IL 60510*

ANDREW SESSLER  
*Lawrence Berkeley National Laboratory, Berkeley, CA 94720*

Parameters are given of 4 TeV and 0.5 TeV (c-of-m) high luminosity  $\mu^+\mu^-$  colliders, and of a 0.5 TeV lower luminosity demonstration machine. We discuss the various systems in such muon colliders, starting from the proton accelerator needed to generate the muons and proceeding through muon cooling, acceleration and storage in a collider ring. Detector background, polarization, and nonstandard operating conditions are analyzed. Muon Colliders have unique technical and physics advantages and disadvantages when compared with both hadron and electron machines. They should thus be regarded as complementary. We briefly mention the luminosity requirements of hadrons and lepton machines and their high-energy-physics advantages and disadvantages in reference to their effective center of mass energy. Finally, we present an R & D plan to determine whether such machines are practical.

## 1 Introduction

This report summarizes briefly the work reported in  $\mu^+\mu^-$  Collider: A Feasibility Study,<sup>1</sup> prepared for Snowmass and also will include some of the results and conclusions reached at the workshop. The possibility of muon colliders was introduced by Skrinsky et al.<sup>2</sup> and Neuffer<sup>3</sup> and has been aggressively developed over the past two years in a series of collaboration meetings and workshops.<sup>4-7</sup> These studies have concentrated on a 4 TeV version of a muon collider with characteristics that are displayed in Tb.1. Parameters are also given of a 0.5 TeV machine. It is obvious that machines with these characteristics can address the outstanding physics questions that we now face.

Before going into a complete description of the machine, we discuss the general question of **why study a muon collider?** There are several components to the answer.

- Synchrotron radiation from a charged particle varies inversely as the fourth power of the mass. Thus, it is possible to use a conventional

Table 1: Parameters of Collider Rings

c-of-m Energy	TeV	4	.5
Beam energy	TeV	2	.25
Beam $\gamma$		19,000	2,400
Repetition rate	Hz	15	2.5
Proton driver energy	GeV	30	24
Protons per pulse		$10^{14}$	$10^{14}$
Muons per bunch	$10^{12}$	2	4
Bunches of each sign		2	1
Beam power	MW	38	.7
Norm. rms emit. $\epsilon_N$	$\pi$ mm mrad	50	90
Bending Field	T	9	9
Circumference	Km	8	1.3
Ave. ring field $B$	T	6	5
Effective turns		900	800
$\beta^*$ at intersection	mm	3	8
rms I.P. beam size	$\mu m$	2.8	17
Chromaticity		2000-4000	40-80
$\beta_{max}$	km	200-400	10-20
Luminosity	$cm^{-2}s^{-1}$	$10^{35}$	$10^{33}$

circular accelerator for the collider ring. The high luminosity is obtained through the use of the same particles for more than 1,000 bunch crossings before the muon lifetime reduces the luminosity significantly.

- The full energy of the projectile is available for exploring the production of new particles. This is in contrast to a proton collider where only a small fraction of the proton's momentum is available in the quark subsystems at integral collision. A 2 x 2 TeV muon collider is a well matched complement to the LHC.
- Both beams may be partially polarized albeit at the cost of some reduction in the luminosity. This is an important feature for studying and classifying new particles.
- The machine has many attractive features, it is fairly compact and can fit on existing sites. A scale drawing of a possible 4 TeV collider is shown in Fig.1 which gives one a feeling for the size of the machine. After the source is developed, one envisages a collider operating at low energy such as 250 x 250 GeV. As one understands the problems and gains experience,

### 0.25 - 1.3 TeV & 1.3 - 2 TeV Accelerators

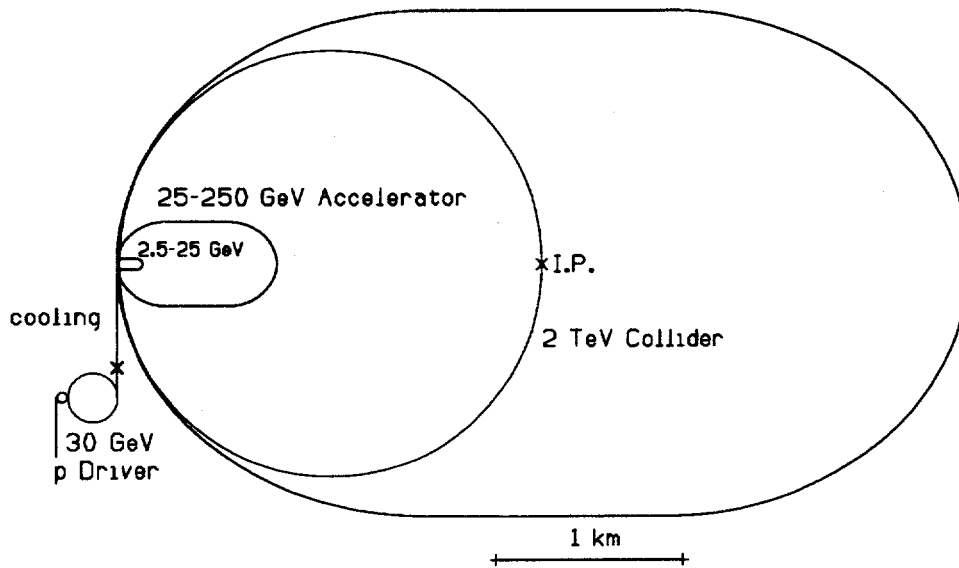

Figure 1: Possible layout of accelerators

the energy of the collider would be increased. A major portion of the cost of a 2 TeV machine is in the final acceleration and collider and would be spread out in time as the machine energy evolves. Each stage would open up a new energy region. The beams of muons, neutrinos, and kaons in the complex are very intense and offer many opportunities for new physics. In particular, neutrino physics, rare muon decay experiments, and rare K decay experiments would be ideally suited for such a facility. Rare decays such as  $\mu \rightarrow e + \gamma$  may be one of our few handles on unraveling physics at the very high mass scale.

- The machine complex can have a very long lifetime as its energy is gradually extended and its facilities are fully exploited. This type of progressive exploitation of a facility may be a much better match to the funding scenarios that high energy physics can expect in the future.

### 1.1 Technical Difficulties

The above advantages do not come without an accompanying set of difficulties that are still not completely understood. The feasibility study<sup>1</sup> has made strides toward answering some of these questions but much work remains to be done. So far no insurmountable difficulties have appeared to challenge the concept of a successful muon collider. However, there are technical problems that still must be solved. Since muons only last for about  $2\mu\text{s}$  in their rest coordinate system, it becomes a challenge to produce and cool the required  $2 \times 10^{12}$  muons of each sign before a significant loss through decay has occurred. Once they are at 2 TeV, their lifetime is a little over 40 milliseconds which is enough to allow over 1,000 turns in a colliding ring. A major problem occurs from the decay electrons which arise from the decay of the muons. These electrons heat the superconducting magnets both through the direct showers that they produce as well as the synchrotron radiation that they emit in the magnetic field, and in the interaction region they cause serious backgrounds for the detector. Finally, we note that the muons are created into a rather diffused phase space; it becomes a tremendous technological challenge to collect these muons into two bunches of  $2 \times 10^{12}$  each, accelerate them, and inject them into a collider ring with a small, well-defined emittance.

We think the feasibility study has addressed many of these problems and suggested preliminary solutions. Over the next year or so we expect that additional simulation studies will define the experimental hardware development effort needed to complement these theoretical studies.

### 1.2 Comparison with Hadron Colliders

We briefly digress here to discuss the concept of *effective* energy in hadron colliders and its relation with luminosity.

#### General

Hadron-hadron colliders ( $pp$  or  $p\bar{p}$ ) generate interactions between the many constituents of the hadrons (gluons, quarks and antiquarks); the initial states are not defined and most interactions occur at relatively low energy generating a very large background of uninteresting events. The rate of the highest energy events is higher for antiproton-proton machines, but this is a small effect for colliders above a few TeV. In either case the effective individual interaction energies are a relatively small fraction of the total center of mass energy. Nevertheless, because high energy hadron machines have been relatively easier and

cheaper to build, and because all final states are accessible, many initial discoveries in Elementary Particle Physics have been made with these machines.

In contrast, lepton-antilepton and photon-photon colliders generate interactions between the fundamental point-like constituents in their beams, the reactions generated are relatively simple to understand and there is no background of low energy events. If the center of mass energy is set equal to the mass of a suitable state of interest, then there can be a large cross section in the *s*-channel, in which a single state is generated by the interaction. In this case, the mass and quantum numbers of the state are constrained by the initial beams. If the energy spread of the beams is sufficiently narrow, then precision determination of masses and widths are possible.

A gamma-gamma collider also has well defined initial states, complementing those attainable with lepton colliders.

For most purposes (technical considerations aside)  $e^+e^-$  and  $\mu^+\mu^-$  colliders would be equivalent. But in the particular case of *s*-channel Higgs boson production, the cross section, being proportional to the mass squared, is more than 40,000 times greater for muons than electrons. When technical considerations are included, the situation is more complicated. Muon beams are harder to polarize and muon colliders will have much higher backgrounds from decay products of the muons. On the other hand muon collider interactions will require less radiative correction and will have less energy spread from beamstrahlung.

Each type of collider has its own advantages and disadvantages for High Energy Physics: they are complementary.

### Required Luminosity for Lepton Colliders

In lepton machines the full center of mass of the leptons is available for the final state of interest and the *effective energy* is equal to the total center of mass energy.

$$E_{\text{eff}} = E_{\text{c of m}} \quad (1)$$

Since fundamental cross sections fall as the square of the center of mass energies involved, so, for a given rate of events, the luminosity of a collider must rise as the square of its energy. A reasonable target luminosity is one that would give 10,000 events per unit of *R* per year:

$$\mathcal{L}_{\text{minimal}} \approx 10^{34} \text{ (cm}^{-2}\text{s}^{-1}\text{)} \left( \frac{E_{\text{eff}}(\text{TeV})}{1 \text{ (TeV)}} \right)^2 \quad (2)$$

where  $1R = \frac{4\pi\alpha^2}{3s} \equiv \frac{86.8 \text{ fb}}{(E_{\text{c of m}}(\text{TeV}))^2}$  for  $e^+e^-$  annihilation. Fig. 2 shows this required luminosity, together with crosses at the approximate achieved lumi-

nosities of some lepton colliders. Target luminosities of possible future colliders are also given as circles.

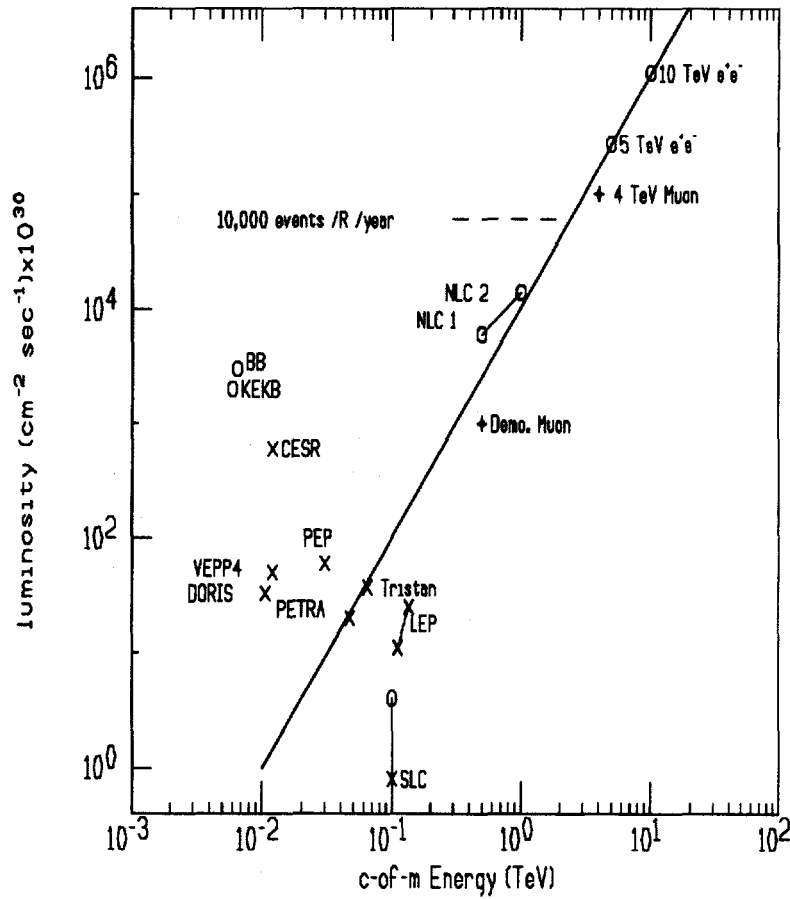

Figure 2: Luminosity of lepton colliders as a function of energy

### The Effective Energies of Hadron Colliders

Hadrons, being composite, have their energy divided between their several constituents. A typical collision of constituents will thus have significantly less energy than that of the initial hadrons. Studies done in Snowmass 82 and 96 suggest that given the required luminosity (as defined in Eq. 2) the hadron

machine's *effective energy* is about 1/10 th of its total:

$$E_{\text{eff}}(\mathcal{L} = \mathcal{L}_{\text{minimal}}) \approx \frac{E_{\text{c of m}}}{10} \quad (3)$$

The same studies have also concluded that a factor of 10 in luminosity is worth about a factor of 2 in effective energy, this being approximately equivalent to:

$$\frac{E_{\text{eff}}}{E_{\text{eff}}(\mathcal{L} = \mathcal{L}_{\text{minimal}})} \approx (\mathcal{L}/\mathcal{L}_{\text{minimal}})^{0.3} \quad (4)$$

Substituting in Eq.4,  $E_{\text{eff}}(\mathcal{L} = \mathcal{L}_{\text{minimal}})$  and Eq. 2 and solving for  $E_{\text{eff}}$ , one obtains:

$$E_{\text{eff}}(\text{TeV}) \approx \left( \frac{E_{\text{c of m}}(\text{TeV})}{10(\text{TeV})} \right)^{\frac{10}{18}} \left( \frac{\mathcal{L}(\text{cm}^{-2}\text{s}^{-1})}{10^{34}(\text{cm}^{-2}\text{s}^{-1})} \right)^{\frac{3}{18}} \quad (5)$$

Fig.3 show the effective energy of colliders as a function of their length.

## 2 Physics Considerations

The physics opportunities and possibilities of the muon collider have been well documented in the Feasibility Study<sup>1</sup> and by additional papers presented at this and previous conferences.<sup>8</sup> The physics reach overlaps that of electron colliders but has some complementary features that we will list here briefly and refer the interested reader to the more complete documentation mentioned above.

A feature that has attracted considerable theoretical interest is the fact that s-channel studies of Higgs production is possible. This is due to the strong coupling of muons to the Higgs channel due to the large mass of the muon. If the Higgs sector is more complex than just a simple SM Higgs, it will be necessary to measure the widths and quantum numbers of any newly discovered particles in order to ascertain the structure of the theory. In addition to the increased coupling strength of the muons, the beamstrahlung, bremsstrahlung and synchrotron radiation is much reduced for muons which allow in principle for much better definition of the beam energy.

A second feature of the muon collider is that the energy of the beam is completely available for the sub-channel process unlike a hadron collider where only a third to a tenth of the proton energy is available. In addition, the energy of a muon collider can be pushed well above the energy reach that has been studied for electron colliders. The advantage is that if SUSY does not exist except as a *theorist's dream* and we are forced to a much higher mass scale to

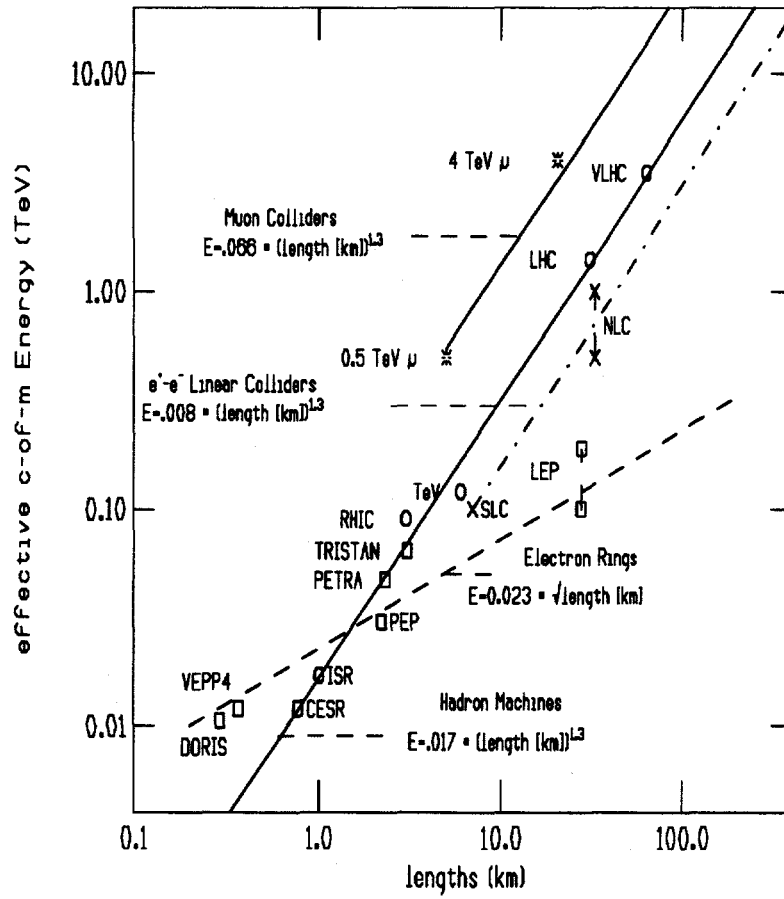

Figure 3: Effective energies of colliders as a function of their total length.

study the symmetry breaking process then the muon collider is still a viable choice as the 1 TeV scale for WW scattering is well within range of the machine being studied.

There are several hardware questions that must be carefully studied. The first is the question of the luminosity available when the beam momentum spread is decreased. Chapter 2 of the Feasibility Study<sup>1</sup> indicates that for some cases a beam momentum spread of the order of 0.01 % is desirable. In addition there will have to be good control of the injected beam energy as

there is not time to make large adjustments in the collider ring. Finally, the question of luminosity vs. percent polarization needs additional study; unlike the electron collider, both beams can be polarized but as shown later in this report the luminosity decreases as the polarization increases.

### 3 Components

The basic components of the  $\mu^+\mu^-$  collider are shown schematically in Fig.4. Tb.1 shows parameters for the candidate designs. The normalized emittance  $\epsilon^N$  is defined as the *rms* transverse phase space divided by  $\pi$ . Notice that more precisely a factor of  $\pi$  must appear in the dimensions of emittance (i.e.  $\pi$  mm mrad).

A high intensity proton source is bunch compressed and focused on a heavy metal target. The pions generated are captured by a high field solenoid and transferred to a solenoidal decay channel within a low frequency linac. The linac serves to reduce, by phase rotation, the momentum spread of the pions, and of the muons into which they decay. Subsequently, the muons are cooled by a sequence of ionization cooling stages. Each stage consists of energy loss, acceleration, and emittance exchange by energy absorbing wedges in the presence of dispersion. Once they are cooled the muons must be rapidly accelerated to avoid decay. This can be done in recirculating accelerators (à la CEBAF) or in fast pulsed synchrotrons. Collisions occur in a separate high field collider storage ring with a single very low beta insertion.

#### 3.1 Proton Driver

The proton driver is a high-intensity (four bunches of  $2.5 \times 10^{13}$  protons per pulse) 30 GeV proton synchrotron, operating at a repetition rate of 15 Hz. Two of the bunches are used to make  $\mu^+$ 's and two to make  $\mu^-$ 's. Prior to targeting the bunches are compressed to an rms length of 1 ns.

For a demonstration machine using the AGS,<sup>9</sup> two bunches of  $5 \times 10^{13}$  at a repetition rate of 2.5 Hz at 24 GeV could be used. Continuing studies are being carried out to optimize the driver for the final machine.<sup>10-12</sup>

#### 3.2 Target

Predictions of nuclear Monte-Carlo(MC) programs<sup>13-16</sup> suggest that  $\pi$  production is maximized by the use of heavy target materials, and that the production is large at a relatively low pion energy, substantially independent of the initial proton energy. An experiment E910,<sup>17</sup> currently running at the AGS, should calibrate the MC programs, and settle at which energy the capture

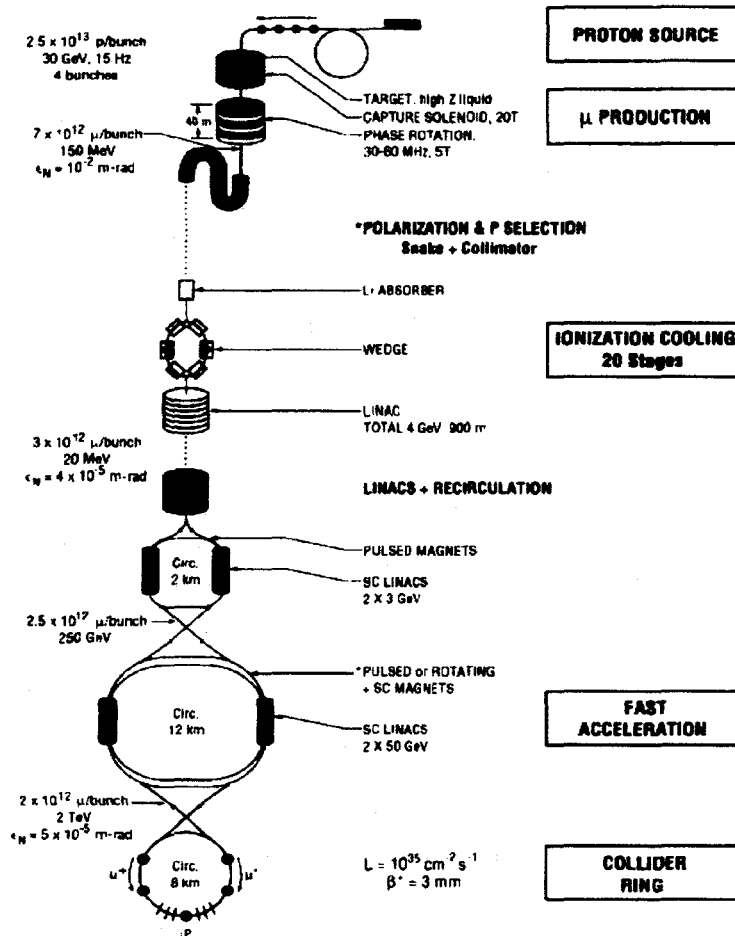

Figure 4: Schematic of a Muon Collider.

should be optimized. Some results from this experiment were presented at this Workshop.<sup>18</sup>

Thermal cooling requirements dictate that the target be liquid: liquid lead and gallium are under consideration. In order to avoid shock damage to a container, the liquid may be in the form of a jet.

## Pion Capture

Pions are captured from the target by a high-field (20 T, 15 cm inside diameter) hybrid magnet: superconducting on the outside, and a water cooled Bitter solenoid on the inside. A preliminary design<sup>19</sup> has an inner Bitter magnet with an inside diameter of 24 cm (space is allowed for a 4 cm heavy metal shield inside the coil) and an outside diameter of 60 cm; it provides half (would consume approximately 8 MW. The superconducting magnet has a set of three coils, all with inside diameters of 70 cm and is designed to give 10 T at the target and provide the required tapered field<sup>20</sup> to match into the decay channel.

## Decay Channel and Phase Rotation Linac

The decay channel consists of a periodic system of superconducting solenoids (5 T and radius = 15 cm). If a simple channel is used then the pions, and the muons into which they decay, will have an energy spread with an rms/mean of  $\approx 100\%$ , and a peak at about a few hundred MeV. It would be difficult to handle such a wide spread in any subsequent system. A linac is thus introduced along the decay channel, with frequencies and phases chosen to deaccelerate the fast particles and accelerate the slow ones; i.e. to phase rotate the muon bunch. Tb.2 gives an example of parameters of such a linac.

Table 2: Parameters of Phase Rotation Linacs

Linac	Length m	Frequency MHz	Gradient MeV/m
1	3	60	5
2	29	30	4
3	5	60	4
4	5	37	4

After this phase rotation, a bunches are selected with mean energy 150 MeV, rms bunch length 1.7 m, and rms momentum spread 20% (95%,  $\epsilon_L = 3.2$  eVs). The number of muons per initial proton in this selected bunch is  $\approx 0.3$ .

## Polarization Selection

In the center of mass of a decaying pion, the outgoing muon is fully polarized (-1 for  $\mu^+$  and +1 for  $\mu^-$ ). In the lab system the polarization depends<sup>21</sup> on the decay angle  $\theta_d$  and initial pion energy. For pion kinetic energy larger than

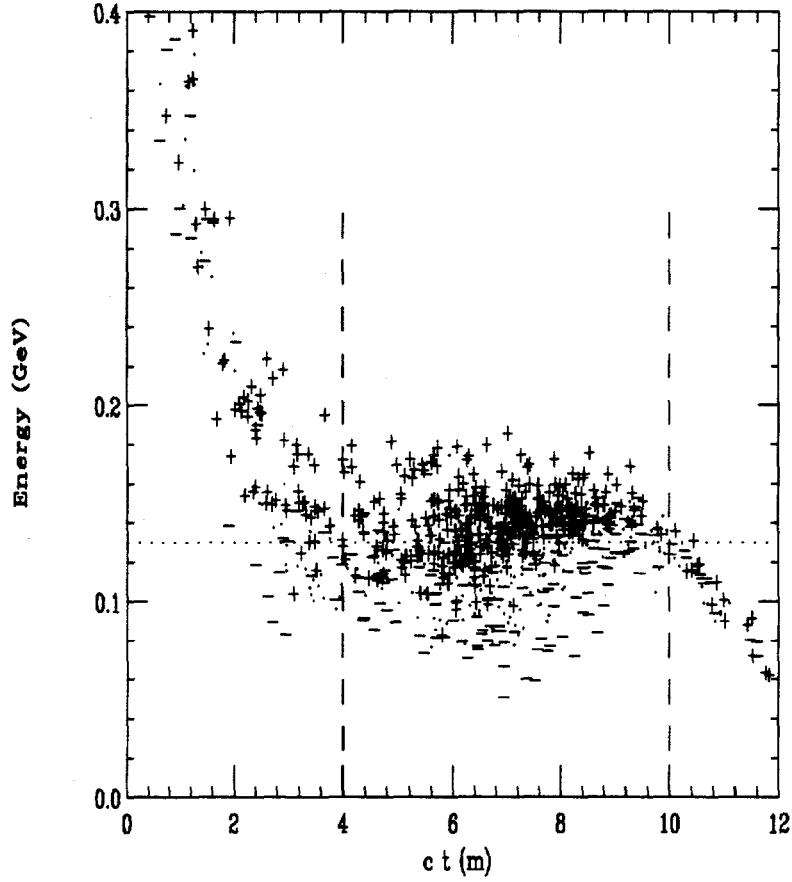

Figure 5: Energy vs  $ct$  of muons at end of decay channel with phase rotation. muons with polarization  $P > \frac{1}{3}$ ,  $-\frac{1}{3} < P < \frac{1}{3}$  and  $P < -\frac{1}{3}$  are marked by the symbols '+', '.' and '-' respectively.

the pion mass, the dependence on pion energy becomes negligible and the polarization is given approximately by:

$$P_{\mu^-} \approx \cos \theta_d + 0.28(1 - \cos^2 \theta_d) \quad (6)$$

The average value of  $P_{\mu^-}$  is about 0.19. If higher polarization is required, some selection of muons from forward pion decays ( $\cos \theta_d \rightarrow 1$ ) is required (see Fig. 5).

This can be done by momentum selecting the muons at the end of the decay and phase rotation channel. A snake<sup>22</sup> could be used to generate the required dispersion. Varying the selected minimum momentum of the muons yields polarization as a function of luminosity loss as shown in Fig.6.

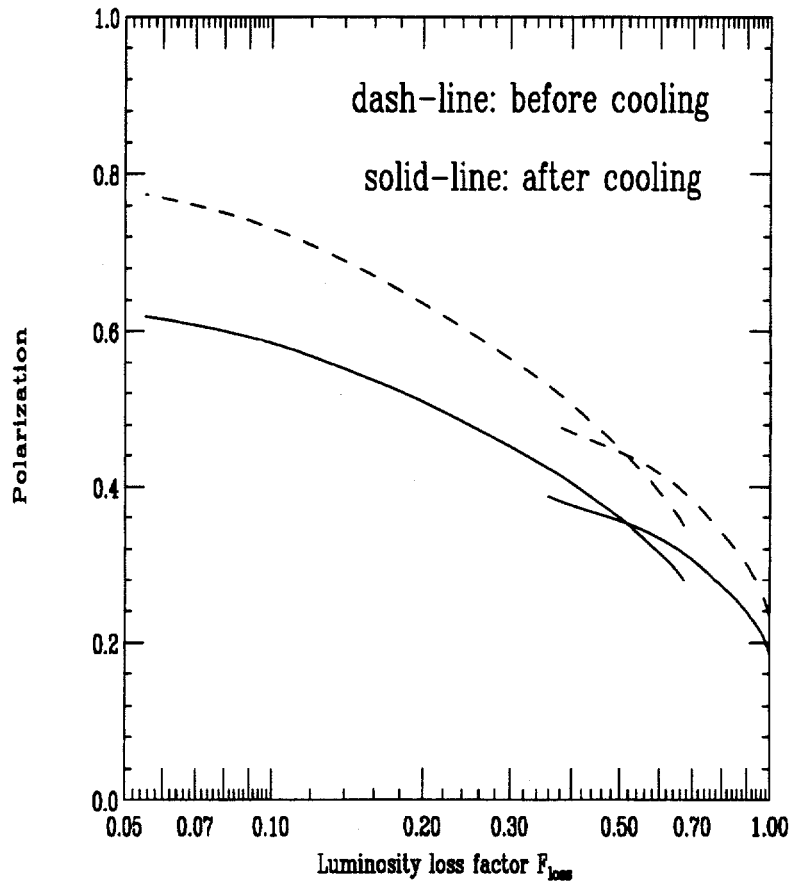

Figure 6: Polarization vs  $F_{\mu}$  of muons accepted; the dashed line shows polarization as selected before cooling; the solid line gives the polarization after cooling.

### 3.3 Ionization Cooling

For the required collider luminosity, the phase-space volume must be greatly reduced; and this must be done within the  $\mu$  lifetime. Ionization cooling<sup>23</sup>

of muons seems relatively straightforward in theory but will require extensive simulation studies and hardware development for its optimization.

### Ionization Cooling Theory

In ionization cooling, the beam loses both transverse and longitudinal momentum as it passes through a material medium. Subsequently, the longitudinal momentum can be restored by coherent reacceleration, leaving a net loss of transverse momentum.

The equation for transverse cooling (with energies in GeV) is:

$$\frac{d\epsilon_n}{ds} = -\frac{dE_\mu}{ds} \frac{\epsilon_n}{E_\mu} + \frac{\beta_\perp(0.014)^2}{2 E_\mu m_\mu L_R}, \quad (7)$$

where  $\epsilon_n$  is the normalized emittance,  $\beta_\perp$  is the betatron function at the absorber,  $dE_\mu/ds$  is the energy loss, and  $L_R$  is the radiation length of the material. The first term in this equation is the coherent cooling term, and the second is the heating due to multiple scattering. This heating term is minimized if  $\beta_\perp$  is small (strong-focusing) and  $L_R$  is large (a low-Z absorber).

The equation for energy spread (longitudinal emittance) is:

$$\frac{d(\Delta E)^2}{ds} = -2 \frac{d\left(\frac{dE_\mu}{ds}\right)}{dE_\mu} <(\Delta E_\mu)^2> + \frac{d(\Delta E_\mu)_{\text{straggling}}^2}{ds} \quad (8)$$

where the first term is the cooling (or heating) due to energy loss, and the second term is the heating due to straggling and the heating term (energy straggling) is given by<sup>24</sup>

$$\frac{d(\Delta E_\mu)_{\text{straggling}}^2}{ds} = 4\pi (r_e m_e c^2)^2 N_o \frac{Z}{A} \rho \gamma^2 \left(1 - \frac{\beta^2}{2}\right), \quad (9)$$

where  $N_o$  is Avogadro's number and  $\rho$  is the density.

Energy spread is reduced by artificially increasing  $\frac{d(dE_\mu/ds)}{dE_\mu}$  by placing a transverse variation in absorber density or thickness at a location where position is energy dependent, i.e. where there is dispersion. The use of such wedges can reduce energy spread, but it simultaneously increases transverse emittance in the direction of the dispersion. It thus allows the exchange of emittance between the longitudinal and transverse directions.

### Cooling System

We require a reduction of the normalized transverse emittance by almost three orders of magnitude (from  $1 \times 10^{-2}$  to  $5 \times 10^{-5}$  m-rad), and a reduction of the

longitudinal emittance by one order of magnitude. This cooling is obtained in a series of cooling stages. In general, each stage consists of three components with matching sections between them:

1. a FOFO lattice consisting of spaced axial solenoids with alternating field directions and lithium hydride absorbers placed at the centers of the spaces between them, where the  $\beta_{\perp}$ 's are minimum.
2. a lattice consisting of more widely separated alternating solenoids, and bending magnets between them to generate dispersion. At the location of maximum dispersion, wedges of lithium hydride are introduced to interchange longitudinal and transverse emittance.
3. a linac to restore the energy lost in the absorbers.

In a few of the later stages, current carrying lithium rods might replace item (1) above. In this case the rod serves simultaneously to maintain the low  $\beta_{\perp}$ , and attenuate the beam momenta. Similar lithium rods, with surface fields of 10 T, were developed at Novosibirsk and have been used as focusing elements at FNAL and CERN.<sup>25</sup> It is hoped<sup>26</sup> that liquid lithium columns, can be used to raise the surface field to 20 T and improve the resultant cooling.

The emittances, transverse and longitudinal, as a function of stage number, are shown in Fig.7, together with the beam energy. In the first 15 stages, relatively strong wedges are used to rapidly reduce the longitudinal emittance, while the transverse emittance is reduced relatively slowly. The object is to reduce the bunch length, thus allowing the use of higher frequency and higher gradient rf in the reacceleration linacs. In the next 10 stages, the emittances are reduced close to their asymptotic limits. In the last stages, the emittance is further reduced in current carrying lithium rods. In order to obtain the required very low equilibrium transverse emittance, the energy is allowed to fall to 15 MeV, thus increasing the focussing strength and lowering the  $\beta$ . The use of such a low energy results in a blow up of the longitudinal emittance and, at this stage, no attempt is made to correct it by the use of dispersion and wedges. The result is an effective exchange of longitudinal and transverse emittances, with little change in the overall six dimensional phase space.

The total length of the system is 750 m, and the total acceleration used is 4.7 GeV. The fraction of muons that have not decayed and are available for acceleration is calculated to be 55 %.

### 3.4 Acceleration

Following cooling and initial bunch compression the beams must be rapidly accelerated to full energy (2 TeV, or 250 GeV).<sup>27</sup> A sequence of linacs would work,

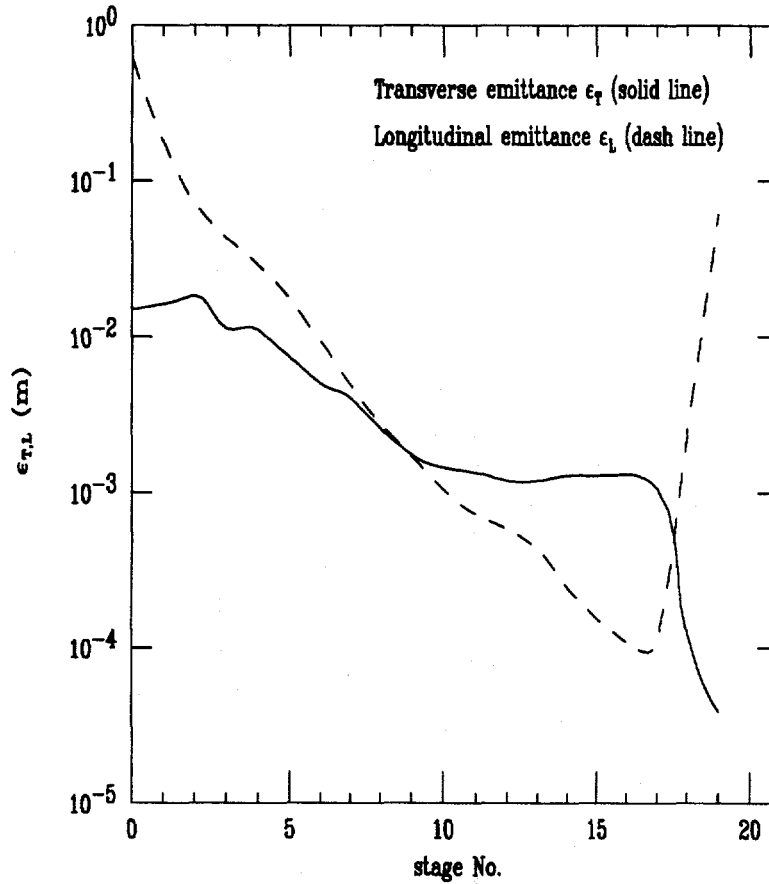

Figure 7:  $\epsilon_L$  and  $\epsilon_T$  vs stage number in the cooling sequence.

but would be expensive. A sequence of recirculating accelerators (similar to that used at CEBAF) could be used, but would also be relatively expensive. A more economical solution would be to use fast pulsed magnets in synchrotrons with rf systems consisting of significant lengths of superconducting linac. This prospect is being studied.

For the final acceleration to 2 TeV in the high energy machine, the power consumed by a ring using only pulsed magnets would be excessive, but if rings of alternating pulsed and superconducting magnets<sup>28,29</sup> are used, then the power consumption can be made reasonable.

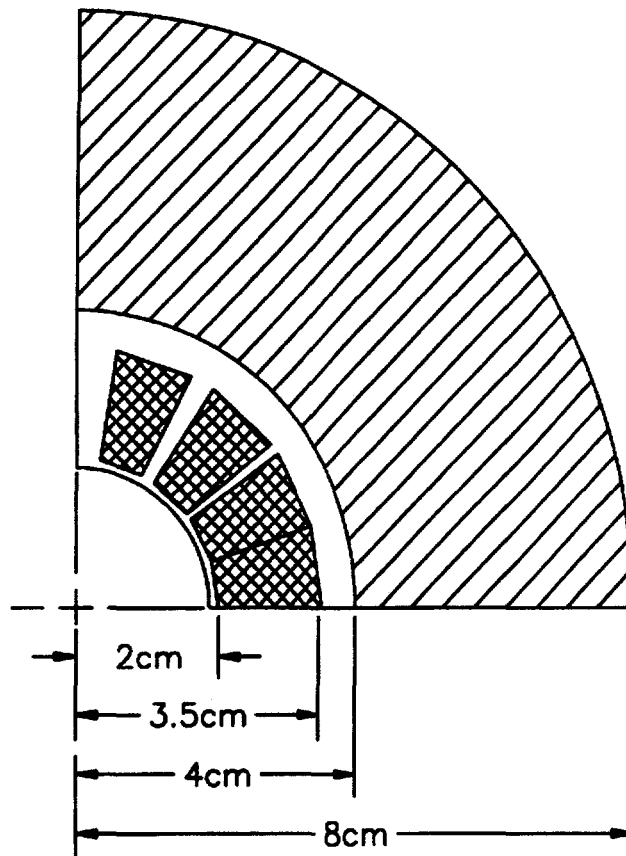

Figure 8: Cross section of pulsed magnet for use in the acceleration to 250 GeV.

Tb.3 gives an example of a possible sequence of such accelerators. Fig. 1 also shows the layout of this sequence. The first two rings use pulsed cosine theta magnets with peak fields of 3 and fixed magnets alternating with  $\pm 2$  T iron yoke pulsed magnets. The latter two rings share the same tunnel, and might share the same linac too. The survival from decay after all four rings is 67%. A recent study<sup>27</sup> tracked particles through a similar sequence of recir-

culating accelerators and found a dilution of longitudinal phase space of the order of 15% and negligible particle loss.

Table 3: Parameters of Pulsed Accelerators

	Ring	1	2	3	4
$E_{init}$	(GeV)	2.5	25	250	1350
$E_{final}$	(GeV)	25	250	1350	2000
fract pulsed	%	100	100	73	44
$B_{pulsed}$	(T)	3	4	$\pm 2$	$\pm 2$
Acc/turn	(GeV)	1	7	40	40
Acc Grad	(MV/m)	10	12	20	20
RF Freq	(MHz)	100	400	1300	1300
circumference	(km)	0.4	2.5	12.8	12.8
turns		22	32	27	16
acc. time	( $\mu s$ )	26	263	1174	691
ramp freq	(kHz)	12.5	1.3	0.3	0.5
loss	(%)	13.4	13.2	9.0	2.2

### 3.5 Collider Storage Ring

After acceleration, the  $\mu^+$  and  $\mu^-$  bunches are injected into a separate storage ring. The highest possible average bending field is desirable to maximize the number of revolutions before decay, and thus maximize the luminosity. Collisions would occur in one, or perhaps two, very low- $\beta^*$  interaction areas.<sup>30,31,32</sup> Parameters of the ring were given earlier in Tb 1.

#### Bending Magnet Design

The magnet design is complicated by the fact that the  $\mu$ 's decay within the rings ( $\mu^- \rightarrow e^- \bar{\nu}_e \nu_\mu$ ), producing electrons whose mean energy is approximately 0.35 that of the muons. These electrons travel toward the inside of the ring dipoles, radiating a fraction of their energy as synchrotron radiation towards the outside of the ring, and depositing the rest on the inside. The total average power deposited, in the ring, in the 4 TeV machine is 13 MW, yet the maximum power that can reasonably be taken from the magnet coils at 4 K is only of the order of 40 KW.

The beam must thus be surrounded by a  $\approx 6$  cm thick warm shield, which is located inside a large aperture conventional superconducting magnet.<sup>32</sup> The quadrupoles can use warm iron poles placed as close to the beam as practical, with coils either superconducting or warm, as dictated by cost considerations.

## Lattice

In order to maintain a bunch with rms length 3 mm, without excessive rf, an isochronous lattice, of the dispersion wave type<sup>30</sup> is used. For the 3 mm beta at the intersection point, and limiting the quadrupole tip field to 6 Tesla, the maximum beta's in both x and y are of the order of 400 km (14 km in the 0.5 TeV machine). Local chromatic correction<sup>31,32</sup> is essential.

Two lattices have been generated<sup>32,33</sup> one of which with the application of octupole and decapole correctors,<sup>33</sup> has an adequate calculated dynamic aperture. As a result of work at this workshop, it was possible to generate a new lattice and IR section with much more desirable properties than were in the previously reported versions. It was discovered how to shield the quadrupoles in the IR from the intense radiation produced by muon decay electrons and simultaneously reduce the background in the detector.<sup>35</sup>

Studies<sup>34</sup> of the resistive wall impedance instabilities indicate that the required muon bunches would be unstable in a conventional ring if uncorrected. In any case, the rf requirements to maintain such bunches would be excessive. BNS<sup>36</sup> damping, applied by rf quadrupoles, is one possible solution, but needs more careful study.

### 3.6 Muon Decay Background

A first Monte Carlo study<sup>37</sup> of the muon decay background was done with the MARS95 code,<sup>14</sup> based on a preliminary insertion lattice. More recent work using both MARS95 and GEANT<sup>29,38</sup> have studied backgrounds with a number of different shielding configurations and lattices.

The early studies indicated the serious nature of the background problem. It became clear that the beam pipe must be surrounded by a tungsten shield that is extended, as a cone, down towards the vertex. Designs have been studied in which this cone had a half angle of between 10 and 20 degrees, and extended to within 6 to 15 cm of the vertex. Different dimensions and shapes have been tried, and the optimum design is yet to be determined. In addition, careful design of beam collimators approaching the intersection point is required, and boron or other neutron absorbing materials must be used.

With such shields, the backgrounds estimated from Monte Carlo studies, indicate that a suitable detector should be able to operate, and physics be analyzed. The situation appears not significantly worse than that encountered in an LHC detector, and further shielding optimization is expected to improve the situation.

The choice of detectors must take into account the requirements of the physics and their ability to operate in the background environment. The high-

est possible granularity will be needed. The fact of relatively long ( $10 \mu s$ ) pauses between bunch crossings can allow the use of drift devices such as Time Projection Chambers (TPC's) and silicon drift chambers, both of which would allow high granularity without excessive cost.

Tb. 4 gives the fluxes of different particles at a radius of 10 cm from the vertex, obtained by one of the Monte Carlo studies,<sup>29</sup> together with their mean energies, hits per  $cm^2$  and occupancies for two possible detectors: a) a silicon drift chamber with 0.3 by 0.3 mm pixels, and b) a micro strip Time Projection Chamber (TPC) with pixel size 0.2 by 1 mm (in z).

Table 4: Background rates at a 10 cm radius

			Silicon Drift		Micro TPC	
	flux $cm^{-2}$	$\langle E \rangle$ MeV	hits $cm^{-2}$	Occup. %	hits $cm^{-2}$	Occup. %
$\gamma$	10000	1	20	2	.5	10*
n	3000	10	3	0.3	.06	.01
$e^{\pm}$	20	1	20	2	20	4
$\pi^{\pm}$	10	240	10	1	10	2
p	2	30	2	0.2	2	0.4
$\mu^{\pm}$	1	24000	1	0.1	1	0.2
total			56	6	34	17*

The two entries with relatively high occupancy, indicated with a \*, reflect the fact that a gamma if stopped in the TPC gas will generate a low momentum electron that spirals down the full length of the TPC (taken to be 100 mm in this example). Such occupancy is less serious than a normal background, since its presence is clearly identified. At larger radii, the gamma background falls rapidly and a more conventional TPC could be used. Background tracks, coming mostly parallel to the axis, would not be confused with tracks coming from the vertex.

Near the vertex, silicon drift chambers, or even more finely divided pixel detectors are preferred, but for the problem of radiation damage. Only about 1/3 of the neutrons have energies above 100 KeV and contribute to this damage, but the integrated flux per year for this example would still be  $3 \cdot 10^{14} \text{ n/s cm}^{-2} \text{ year}^{-1}$  which might render such detectors inoperable after about one year. It is for this reason that the example of the micro TPC, which would not suffer such damage, is included.

The effect of these backgrounds in the electromagnetic calorimeter, assumed to have 2 x 2 cm towers, would be to introduce pedestals of about 100 MeV and fluctuations of about 50 MeV: neither serious. In the hadron

calorimeter, the effect of all backgrounds, except the muons, would be to introduce a 2 GeV pedestals with 300 MeV fluctuations: also acceptable. But the muons, arising from Bethe-Heitler pair production in EM showers or from a halo in the machine, though modest in number, have high average energies. They would not be a problem in the tracking detectors. But in the calorimeters, they would occasionally induce deeply inelastic interactions, depositing clumps of energy deep in the absorbers. If a calorimeter is not able to recognize the direction of such interactions (they will be pointing along the beam axis) then they would produce unacceptable fluctuations in hadron energy determination. It has been suggested that segmenting the calorimetry in depth would allow these interactions to be subtracted. We are studying various solutions, but ultimately there will have to be some hardware tests to verify the MC study.

There could be a very serious background from the presence of even a very small halo of near full energy muons in the circulating beam.<sup>39</sup> The beam will need careful preparation before injection into the collider, and a collimation system will have to be designed to be located on the opposite side of the ring from the detector.

Background reduction is one of the most important areas to be studied in the future. The coupling between the machine design and the detector is very tight, and as has been the case with synchrotron radiation shielding for e+e-rings can be reduced through careful design. This process has just started and we are developing programs that will enable us to calculate the flux of various species of particles more efficiently.

During the conference, as mentioned, new ideas for shielding,<sup>35</sup> including the introduction of additional bending magnets near the intersection point, have resulted in reduced backgrounds in the detector region. These gains are not reflected in the numbers given above. Studies are still in progress using GEANT and MARS to model these backgrounds and we do not yet have detailed results for the new IR configuration.

There is also a small background from incoherent (i.e.  $\mu^+\mu^- \rightarrow e^+e^-$ ) pair production in the 4 TeV Collider case.<sup>40</sup> The cross section is estimated<sup>41</sup> to be 10 mb, which would give rise to a background of  $\approx 3 \cdot 10^4$  electron pairs per bunch crossing. Approximately 90% of these, will be trapped inside the tungsten nose cone, but those with energy between 30 and 100 MeV will enter the detector region. They do not seem to be a serious problem.

## 4 Research and Development Plan

In this section we discuss a Research and Development plan aimed at the operation of a 0.5 TeV demonstration machine by the year 2010, and of the 4 TeV machine by year 2020. It assumes 5 years of theoretical study, component modeling and critical subsystem demonstration; followed by 4 years of component development and demonstration machine design. Construction of the demonstration machine would follow and take about 4 years. The high energy machine would come a decade later.

### 4.1 Theoretical Studies

Much progress has been made during the last year. New problems continue to be uncovered, but new solutions have been found. Much work remains to be done: The first object will be to define a single self consistent set of parameters for the 4 TeV collider. Items needing study include:

1. Define parameters for the p source, target, capture and phase rotation systems.
2. Incorporate operating parameters for the optional operation with polarized, or very low energy spread, beams.
3. Define and simulate a complete cooling scenario.
4. Define a preferred acceleration scenario and perform complete simulations. Study the required shielding of the superconducting cavities from muon decay electrons.
5. Design a halo scraping system for the collider ring.
6. Continue work on the collider lattice, including a study of the effect of lattice errors, and an investigation of the use of higher order multipole correctors. Continue the study of the stability of the proposed beams and design an rf system for BNS damping.
7. Continue optimization of the shielding of the detector.
8. Design a 'straw man' detector with all components capable of withstanding the backgrounds, and simulate some representative physics observations.
9. Study safety and radiation exposures both on and off site, including the hazards from neutrino fluxes.

#### *4.2 Component Development and Demonstrations*

Theoretical studies alone will not be sufficient to determine the practicality of a muon collider. Experimental studies are essential. Some such studies can be undertaken without new funding, but the major efforts will require specific support.

#### **Proton Driver Experimental R & D**

Beam dynamic experiments at the BNL AGS will be needed, but should not be expensive. A modification of the AGS to avoid transition in that machine, and study the resulting improvements in phase space density would be very desirable, but the cost should probably be justified as an AGS improvement, rather than as a muon collider experiment.

#### **Target, Capture and Decay Channel Experimental R & D**

An experiment<sup>17,18</sup> has taken data and is currently being analyzed, to determine pion production at its low energy maximum. This data, together with assumptions on pion reabsorption should allow more realistic Monte-Carlo calculations of total pion yield and capture in a solenoid. Never the less there are several reasons why a demonstration of such capture is desirable:

- Thermal cooling requirements dictate that the target be liquid: liquid lead and gallium are under consideration. In order to avoid shock damage to a container, the liquid may need to be in the form of a jet. Since the magnetic field over the target will effect both the heat distribution in, and forces on, such a jet, an experiment is required.
- The simulation must make assumptions on the cross sections for secondary pion production by products of the primary interaction. This information is needed at low final energies and large angles where data is inadequate. A Conventional experiment to determine all such cross sections would be expensive. It will be more practical and reliable to measure the resulting yield in a demonstration experiment using the proposed target and capture magnetic field.
- We need to know the total radiation directed towards the capture and focusing solenoids. Shielding will have to be provided to protect the insulation of the inner resistive solenoid, and limit heating of the outer superconducting magnets. Monte Carlo simulations indicate that such shielding is reasonable, but only direct measurement of such radiation provide a reliable determination.

- In the current preferred design of phase rotation, the first rf cavity is placed 3 m from the target. If unshielded, the radiation level at this point will be very high. Shielding will be needed, but we have little data on the performance of a cavity under such conditions and thus have difficulty calculating the shielding requirements. Experimental studies are needed, and the most direct and reliable experiment would be to model the actual target, capture, and first cavity and expose it to pulses of the specified proton intensity.

For all these reasons we will propose a demonstration capture experiment. The most appropriate beam for such an experiment would be at the BNL AGS, since pulses at near 30 GeV and  $10^{14}$  protons should be available.

The liquid target development would be undertaken in collaboration with the similar work being undertaken for spallation source target development. It is expected that a target area for that work will be made available, and this experiment would share the same area.

The cost of the 20 Tesla solenoid can be reduced by making it a nitrogen cooled pulsed resistive solenoid with no superconducting outer coil. It would be hoped to use the existing MPS power supply. A suitable 100 MHz cavity may be available, but a high power tetrode to pulse it would be needed.

### **Ionization Cooling Experimental R & D**

Although the principals of ionization cooling are relatively simple, there are practical problems in designing lattices that can transport, and focus the large emittances without exciting betatron resonances that blow up the emittance and attenuate the beam. There will also be problems with space charge and wake field effects.

After a design has been defined and simulated, demonstrations will be required. These will not be trivial experiments: they will require significant rf acceleration ( $\approx 100$  MeV) and several meters of high field solenoids interspersed with bending magnets and, for a final stage demonstration, current carrying lithium rods.

An R & D program would also be required to develop the current carrying rods. This could be undertaken in a collaboration between BINP, Novosibirsk, and FNAL.

### **Magnet Design and Acceleration Experimental R & D**

R & D programs are required both for the high field pulsed cosine theta magnets and for the lower pulsed field iron dominated magnets. The R and D on

the former would be somewhat more urgent since they are less conventional.

Some R & D work is also needed to determine the performance of the required superconducting cavities when excited for the relatively short pulse durations required. Studies of their sensitivity to muon decay electrons may also be needed. It is hoped that such studies will be undertaken within the context of more general superconducting cavity development.

#### **Collider Ring Experimental R & D**

The insertion quadrupoles need urgent R & D because the lattice design work depends on the gradients that are achieved.  $Nb_3Sn$ , or other higher field conductor will be preferred. Since the magnets operate at a constant field, metallic insulation is probably acceptable, which would obviate the need for impregnation and thus provide better cooling. High  $T_c$  materials should be considered.

The dipole magnets, if of cosine theta design, would probably develop excessive mid plane compression in their coils. Block conductor arrangements will need to be developed. The use of  $Nb_3Sn$  will again be preferred for its high field capability.

#### **Detector Experimental R & D**

Detector R & D is required to develop the required detectors and confirm that they can both withstand the expected radiation and separate the tracks of interest from the background.

### **5 Demonstration Collider**

Parameters of a 0.5 TeV demonstration collider are given in Tb.1 together with those for the 4 TeV machine. The parameters shown are those for a machine based on the AGS as an injector, but it may be assumed that a demonstration version based on upgrades of the FERMILAB machines would also be possible.

It may be noted that this machine has easier parameters for emittance, chromaticity, spot size etc. It is also relatively small: no bigger than RHIC, or the FNAL Main Injector. It would require significantly less extrapolation of our current technologies. At the same time it would be a significant step towards demonstrating the technologies needed for the higher energy machine. It is interesting to ask if the demonstration machine should be capable of upgrade to the higher energy. Clearly this could be considered, but experience with the SLC would suggest that so much would be learned from the demonstration that one would want to start from scratch, incorporating the lessons learned. This

realization could allow acceptance of compromises to keep the demonstration machine as low in cost as possible.

## 6 Conclusion

A great deal of progress has been made on a scenario for a 4 TeV high luminosity muon collider. However many questions remain that will require both theoretical studies as well as R & D on hardware. If the machine design is to be brought to fruition additional funds will have to be made available for these studies.

There are two areas that are especially critical for understanding whether a muon collider is a useful tool for attacking Electro Weak Symmetry Breaking (EWSB).

- The first is to demonstrate muon cooling. This is not a question of physics as the laws governing the interaction of muons with matter are well established; rather it is a question of combining these laws with hardware in a fashion that will be rugged and stable in its operation. Beam losses are especially important to understand as there are many stages in the cooling process and a small inefficiency at each stage can have a serious effect on the luminosity.
- The second critical area concerns the backgrounds in the detector. These must be reduced to acceptable levels. These studies are still at the Monte Carlo stage, but at some point in the future an experimental detector R & D program will have to be supported. We note that for many detector components we can piggy back of the developments for the LHC where many similar problems are being studied. Even so, there are detector problems that are unique to the muon collider that must be studied.

In addition, there are many components that require technical development,

- a large high field solenoid for capture
- low frequency rf linacs
- accelerator magnets, radiation shielding for magnets, and SCRF cavities that operate in a radiation field

None of these components can be described as exotic; many have been built and operated in less stringent conditions. There is a large engineering effort required to bring these components together in a successful collider.

If the components can be developed and the theoretical studies are successful, then the muon collider may play a role in HEP that is complementary to both hadron and electron colliders. *The question is too important to leave unanswered!*

### Acknowledgments

We acknowledge important contributions from many colleagues, especially those that contributed to the feasibility study submitted to the Snowmass 96 Workshop Proceedings and most in particular the Editors of each one of the chapters of the  $\mu^+\mu^-$  Collider: A Feasibility Study report: V. Barger, J. Norem, R. Noble, H. Kirk, R. Fernow, D. Neuffer, J. Wurtele, D. Lissauer, M. Murtagh, S. Geer, N. Mokhov and D. Cline. This work supported by the US Department of Energy under contract DE-ACO2-76-CH00016, DE-AC02-76-CH03000 and DE-AC03-76-SF00098.

1.  $\mu^+\mu^-$  Collider: A Feasibility Study, BNL-52503 Fermi Lab-Conf.-96/092 LBNL-38946; also Proceedings of the Snowmass Workshop 96, to be published.
2. E. A. Perevedentsev and A. N. Skrinsky, Proc. 12th Int. Conf. on High Energy Accelerators, F. T. Cole and R. Donaldson, Eds., (1983) 485; A. N. Skrinsky and V.V. Parkhomchuk, Sov. J. of Nucl. Physics **12**, (1981) 3; *Early Concepts for  $\mu^+\mu^-$  Colliders and High Energy  $\mu$  Storage Rings, Physics Potential & Development of  $\mu^+\mu^-$  Colliders. 2<sup>nd</sup> Workshop*, Sausalito, CA, Ed. D. Cline, AIP Press, Woodbury, New York, (1995).
3. D. Neuffer, IEEE Trans. **NS-28**, (1981) 2034.
4. *Proceedings of the Mini-Workshop on  $\mu^+\mu^-$  Colliders: Particle Physics and Design*, Napa CA, Nucl Inst. and Meth., **A350** (1994) ; Proceedings of the Muon Collider Workshop, February 22, 1993, Los Alamos National Laboratory Report LA- UR-93-866 (1993) and *Physics Potential & Development of  $\mu^+\mu^-$  Colliders 2<sup>nd</sup> Workshop*, Sausalito, CA, Ed. D. Cline, AIP Press, Woodbury, New York, (1995).
5. *Transparencies at the 2 + 2 TeV  $\mu^+\mu^-$  Collider Collaboration Meeting*, Feb 6-8, 1995, BNL, compiled by Juan C. Gallardo; transparencies at the 2 + 2 TeV  $\mu^+\mu^-$  Collider Collaboration Meeting, July 11-13, 1995, FERMILAB, compiled by Robert Noble; Proceedings of the 9th Advanced ICFA Beam Dynamics Workshop, Ed. J. C. Gallardo, AIP Press, Conference Proceedings 372 (1996).
6. D. V. Neuffer and R. B. Palmer, Proc. European Particle Acc. Conf., London (1994); M. Tigner, in *Advanced Accelerator Concepts*, Port Jefferson, NY 1992, AIP Conf. Proc. **279**, 1 (1993).

7. R. B. Palmer et al., *Monte Carlo Simulations of Muon Production, Physics Potential & Development of  $\mu^+\mu^-$  Colliders 2<sup>nd</sup> Workshop*, Sausalito, CA, Ed. D. Cline, AIP Press, Woodbury, New York, pp. 108 (1995); R. B. Palmer, et al., *Muon Collider Design*, in Proceedings of the Symposium on Physics Potential & Development of  $\mu^+\mu^-$  Colliders, Nucl. Phys. B (Proc. Suppl.) 51A (1996) 61.
8. V. Barger, et al. and J. Gunion et al., this proceedings. V. Barger, *New Physics Potential of Muon-Muon Collider*, Proceedings of the 9th Advanced ICFA Beam Dynamics Workshop, Ed. J. C. Gallardo, AIP Press, Conference Proceedings 372 (1996).
9. T. Roser, *AGS Performance and Upgrades: A Possible Proton Driver for a Muon Collider*, Proceedings of the 9th Advanced ICFA Beam Dynamics Workshop, Ed. J. C. Gallardo, AIP Press, Conference Proceedings 372 (1996).
10. Y. Cho, et al., *A 10-GeV, 5-MeV Proton Source for a Pulsed Spallation Source*, Proc. of the 13th Meeting of the Int'l Collaboration on Advanced Neutron Sources, PSI Villigen, Oct. 11-14 (1995); Y. Cho, et al., *A 10-GeV, 5-MeV Proton Source for a Muon-Muon Collider*, Proceedings of the 9th Advanced ICFA Beam Dynamics Workshop, Ed. J. C. Gallardo, AIP Press, Conference Proceedings 372 (1996).
11. F. Mills, et al., presentation at the 9th Advanced ICFA Beam Dynamics Workshop, unpublished; see also second reference in ref. 5.
12. T. Roser and J. Norem, private communication.
13. D. Kahana, et al., *Proceedings of Heavy Ion Physics at the AGS-HIPAGS '93*, Ed. G. S. Stephans, S. G. Steadman and W. E. Kehoe (1993); D. Kahana and Y. Torun, *Analysis of Pion Production Data from E-802 at 14.6 GeV/c using ARC*, BNL Report # 61983 (1995).
14. N. V. Mokhov, *The MARS Code System User's Guide*, version 13(95), Fermilab-FN-628 (1995).
15. J. Ranft, DPMJET Code System (1995).
16. N. Mokhov, R. Noble and A. Van Ginneken, *Target and Collection Optimization for Muon Colliders*, Proceedings of the 9th Advanced ICFA Beam Dynamics Workshop, Ed. J. C. Gallardo, AIP Press, Conference Proceedings 372 (1996).
17. See, <http://www.nevis1.nevis.columbia.edu/heavyion/e910>
18. H. Kirk, presentation at the Snowmass96 Workshop, unpublished.
19. R. Weggel, *Collector Magnets for  $\mu^+\mu^-$  Colliders*, unpublished report; R. Weggel, presentation at the Snowmass96 Workshop, unpublished.
20. R. Chehab, J. Math. Phys. 5, (1978) 19.

21. K. Assamagan, et al., Phys Lett. B335, 231 (1994); E. P. Wigner, Ann. Math. 40, 194 (1939) and Rev. Mod. Phys., 29, 255 (1957).
22. F. Chen, *Introduction to Plasma Physics*, Plenum, New York, pp. 23-26 (1974); T. Tajima, *Computational Plasma Physics: With Applications to Fusion and Astrophysics*, Addison-Wesley Publishing Co., New York, pp. 281-282 (1989).
23. Initial speculations on ionization cooling have been variously attributed to G. O'Neill and/or G. Budker see D. Neuffer, Particle Accelerators, 14, (1983) 75; D. Neuffer, Proc. 12th Int. Conf. on High Energy Accelerators, F. T. Cole and R. Donaldson, Eds., 481 (1983); D. Neuffer, in Advanced Accelerator Concepts, AIP Conf. Proc. 156, 201 (1987); see also ref. 2.
24. U. Fano, Ann. Rev. Nucl. Sci. 13, 1 (1963).
25. G. Silvestrov, Proceedings of the Muon Collider Workshop, February 22, 1993, Los Alamos National Laboratory Report LA-UR-93-866 (1993); B. Bayanov, J. Petrov, G. Silvestrov, J. MacLachlan, and G. Nicholls, Nucl. Inst. and Meth. 190, (1981) 9; Colin D. Johnson, Hyperfine Interactions, 44 (1988) 21; M. D. Church and J. P. Marriner, Annu. Rev. Nucl. Sci. 43 (1993) 253.
26. G. Silvestrov, *Lithium Lenses for Muon Colliders*, Proceedings of the 9th Advanced ICFA Beam Dynamics Workshop, Ed. J. C. Gallardo, AIP Press, Conference Proceedings 372 (1996).
27. D. Neuffer, *Acceleration to Collisions for the  $\mu^+\mu^-$  Collider*, Proceedings of the 9th Advanced ICFA Beam Dynamics Workshop, Ed. J. C. Gallardo, AIP Press, Conference Proceedings 372 (1996).
28. D. Summers, presentation at the 9th Advanced ICFA Beam Dynamics Workshop, unpublished.
29. I. Stumer, presentation at the BNL-LBL-FNAL Collaboration Meeting, Feb 1996, BNL, unpublished; see also Chap. 9 in ref. 1.
30. S.Y. Lee, K.-Y. Ng and D. Trbojevic, FNAL Report FN595 (1992); Phys. Rev. E48, (1993) 3040; D. Trbojevic, et al., *Design of the Muon Collider Isochronous Storage Ring Lattice, Micro-Bunches Workshop*, BNL Oct. (1995), AIP Press, Conference Proceedings 367 (1996).
31. K. L. Brown and J. Spencer, SLAC-PUB-2678 (1981) presented at the Particle Accelerator Conf., Washington, (1981) and K.L. Brown, SLAC-PUB-4811 (1988), Proc. Capri Workshop, June 1988 and J.J. Murray, K. L. Brown and T.H. Fieguth, Particle Accelerator Conf., Washington, 1987; Bruce Dunham and Olivier Napoly, *FFADA, Final Focus. Automatic Design and Analysis*, CERN Report CLIC Note 222, (1994); Olivier Napoly, *it CLIC Final Focus System: Upgraded Version with In-*

- creased Bandwidth and Error Analysis, CERN Report CLIC Note 227, (1994).
32. A. Garren, et al., *Design of the Muon Collider Lattice: Present Status*, in *Physics Potential & Development of  $\mu^+\mu^-$  Colliders*, Nucl. Phys. B (Proc. Suppl.) 51A (1996) 148.
  33. K. Oide, private communication.
  34. M. Syphers, private communication; K.-Y. Ng, *Beam Stability Issues in a Quasi-Isochronous Muon Collider*, Proceedings of the 9th Advanced ICFA Beam Dynamics Workshop, Ed. J. C. Gallardo, AIP Press, Conference Proceedings 372 (1996); K.Y. Ng, *Beam Stability Issues in a Quasi-Isochronous Muon Collider*, *ibid.*; W.-H. Cheng, A.M. Sessler, and J.S. Wurtele, *Studies of Collective Instabilities, in Muon Collider Rings*, *ibid.*.
  35. C. Johnstone and A. Garren, Proceedings of the Snowmass Workshop 96 to be published; C. Johnstone and N. Mokhov, *ibid.*.
  36. V. Balakin, A. Novokhatski and V. Smirnov, Proc. 12th Int. Conf. on High Energy Accel., Batavia, IL, 1983, ed. F.T. Cole, Batavia: Fermi Natl. Accel. Lab. (1983), p. 119.
  37. G. W. Foster and N. V. Mokhov, *Backgrounds and Detector Performance at 2 + 2 TeV  $\mu^+\mu^-$  Collider*, *Physics Potential & Development of  $\mu^+\mu^-$  Colliders 2<sup>nd</sup> Workshop*, Sausalito, CA, Ed. D. Cline, AIP Press, Woodbury, New York, pp. 178 (1995).
  38. Geant Manual, Cern Program Library V. 3.21, Geneva, Switzerland, 1993.
  39. N. V. Mokhov and S. I. Striganov, *Simulation of Background in Detectors and Energy Deposition in Superconducting Magnets at  $\mu^+\mu^-$  Colliders*, Fermilab-Conf-96/011, Proceedings of the 9th Advanced ICFA Beam Dynamics Workshop, Ed. J. C. Gallardo, AIP Press, Conference Proceedings 372 (1996).
  40. P. Chen, presentations at the 9th Advanced ICFA Beam Dynamics Workshop and at the 3rd International Conference, *Physics Potential & Development of  $\mu^+\mu^-$  Colliders*.
  41. L. D. Landau and E. M. Lifshitz, Phys. Zs. Sowjetunion 6, 244 (1934); V. M. Budnev, I. F. Ginzburg, G. V. Medelin and V. G. Serbo, Phys Rep., 15C, 181 (1975).