

UN LASSIFIED

ISC-654

I

Subject Category: CHEMISTRY

UNITED STATES ATOMIC ENERGY COMMISSION

MEASUREMENT AND SIGNIFICANCE OF
TRANSPORT NUMBER IN FUSED SALTS

By
Richard W. Laity
Frederick R. Duke

June 1955

Ames Laboratory
Iowa State College
Ames, Iowa

Technical Information Service Extension, Oak Ridge, Tenn.

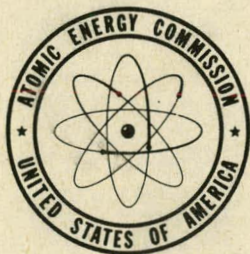

UNCLASSIFIED

DISCLAIMER

This report was prepared as an account of work sponsored by an agency of the United States Government. Neither the United States Government nor any agency Thereof, nor any of their employees, makes any warranty, express or implied, or assumes any legal liability or responsibility for the accuracy, completeness, or usefulness of any information, apparatus, product, or process disclosed, or represents that its use would not infringe privately owned rights. Reference herein to any specific commercial product, process, or service by trade name, trademark, manufacturer, or otherwise does not necessarily constitute or imply its endorsement, recommendation, or favoring by the United States Government or any agency thereof. The views and opinions of authors expressed herein do not necessarily state or reflect those of the United States Government or any agency thereof.

DISCLAIMER

Portions of this document may be illegible in electronic image products. Images are produced from the best available original document.

II

Work performed under Contract No. W-7405-Eng-82.

F. H. Spedding, Director, Ames Laboratory.

LEGAL NOTICE

This report was prepared as an account of Government sponsored work. Neither the United States, nor the Commission, nor any person acting on behalf of the Commission:

A. Makes any warranty or representation, express or implied, with respect to the accuracy, completeness, or usefulness of the information contained in this report, or that the use of any information, apparatus, method, or process disclosed in this report may not infringe privately owned rights; or

B. Assumes any liabilities with respect to the use of, or for damages resulting from the use of any information, apparatus, method, or process disclosed in this report.

As used in the above, "person acting on behalf of the Commission" includes any employee or contractor of the Commission to the extent that such employee or contractor prepares, handles or distributes, or provides access to, any information pursuant to his employment or contract with the Commission.

This report has been reproduced directly from the best available copy.

Printed in USA, Price 40 cents. Available from the Office of Technical Services, Department of Commerce, Washington 25, D. C.

TABLE OF CONTENTS

	Page
I. INTRODUCTION	1
II. A DEFINITION OF TRANSPORT NUMBERS IN FUSED SALTS	2
III. REVIEW OF PREVIOUS WORK	4
IV. DESCRIPTION AND JUSTIFICATION OF A NEW CELL FOR MEASURING TRANSPORT NUMBERS IN PURE FUSED SALTS	16
A. Objectives in Designing the Cell	16
B. The Cell and Accompanying Apparatus	17
C. Experimental Procedure	19
D. Calculation of Transport Numbers from Experimental Data	20
E. Effects of Experimental Variations	22
1. Quantity of added salt	22
2. Cell dimensions	22
3. Temperature	23
4. Porosity and material of the membrane	24
5. Strength of current	24
F. Validity of Transport Numbers Measured by This Method	26
V. A CELL FOR MEASURING THE TRANSPORT NUMBERS OF THE IONS IN MIXTURES OF FUSED SALTS	33
VI. SOME SPECIFIC TRANSPORT NUMBER DETERMINATIONS	37
A. Lead Chloride	38
1. Materials	38
2. Procedure and Observations	38
B. Lead Bromide	38
1. Materials	38
2. Procedure and observations	38
C. Thallous Chloride	39
1. Materials	39
2. Procedure and observations	39
D. Silver Nitrate	43
1. Materials	43
2. Procedure and Observations	43

	Page
E. Equimolar Mixture of Silver Nitrate and Sodium Nitrate	48
1. Materials	48
2. Procedure and results	48
VII. DISCUSSION	51
VIII. SUMMARY	60
IX. LITERATURE CITED	61

MEASUREMENT AND SIGNIFICANCE OF TRANSPORT NUMBERS IN FUSED SALTS*

by

Richard W. Laity and Frederick R. Duke

ABSTRACT

The concept of transport numbers in fused salts is discussed in the light of the inapplicability of the usual definition applied to electrolytic solutions. The lack of a solvent reference frame, with respect to which the mobilities of the ions are normally compared, necessitates employment of a microscopic definition, if the conductance of a molten electrolyte is to be divided into a sum of meaningful ionic conductances. Thus, the reference frame selected here consists of the large bulk of ions not involved in the conductivity process at any given instant, i.e., those ions which lack the necessary energy of activation for migration. The transport numbers are therefore the fractions of current carried by the migrating ions during electrolysis as measured with respect to this frame.

Attempts to previous workers to measure transport numbers in fused salts are reviewed with respect to their validity and significance. It is shown that, while a few of the papers present significant data, the failure of any previous investigators adequately to consider the nature of the quantities they were measuring has led in other cases to publication of completely useless or uninterpretable experimental results.

* This report is based on a Ph.D. Thesis by Richard W. Laity submitted June, 1955, to Iowa State College, Ames, Iowa. This work was done under contract with the Atomic Energy Commission.

A cell for measuring the transport numbers of the ions in pure molten salts is described. It has two vertical electrode compartments separated by a porous glass membrane. The displacement during electrolysis of an air bubble in a capillary tube connecting the two compartments yields data which can be combined with known density data to calculate the transport numbers, assuming the simplest formulas for the current-carrying ions. The validity of the use of this cell is verified for PbCl_2 by showing the lack of dependence of the measured transport numbers on the chemical nature of the membrane, as well as by other experiments and theoretical considerations. A criterion for indicating the applicability of the method to other pure salts, based on the possible influence of the membrane on the experimental activation energy of conductivity, is proposed and its use demonstrated.

A cell for measuring transport numbers in mixtures of fused salts is described. The electrode compartments are again separated by a porous glass membrane. Results with this cell are found by using a suitable analytical procedure to determine the actual quantity of each ion transferred from one compartment to the other on electrolysis.

Application of the former cell to a number of pure fused salts is shown to yield the following experimental transport numbers for the negative ions: PbCl_2 - 0.76 at 565 and at 635°C.; PbBr_2 - 0.65 at 500 and 0.67 at 600°C.; TlCl - 0.49+ at 475, at 505 and at 525°C.; AgNO_3 - about 0.24 at 225 and at 275°C. In a nearly equimolar AgNO_3 - NaNO_3 mixture use of the latter cell is shown to indicate that the nitrate ion carries a negligible fraction of the current, while the maximum transport number of the silver ion is less than 0.67.

An experiment is proposed by which the latter cell might also be used to determine the extent to which complex ions carry current in molten salts. The procedure would involve placing labeled cation or anion in the appropriate compartment and measuring the quantity of labeled ion that moves in the opposite direction from the corresponding electrode. It is shown how such information, combined with that of the type assembled in the present work, may be of considerable use in the development of a theory of the liquid state.

I. INTRODUCTION

Considerable progress toward an understanding of the behavior of solutions of electrolytes has been achieved by considering the equivalent conductivity, Λ , of such solutions to be the sum of the conductivities, λ_i , of the individual ionic species present. The fraction of the total current carried by a given species, i , is thus given by λ_i / Λ . This quantity is known as the transport number, t_i , (also called "transference number") of the ion under consideration. It is clear that a determination of the transport numbers of the ions in a solution, as well as its conductance, is necessary in order to infer the values of λ_i to be ascribed to the various ions.

An understanding of the way in which such factors as temperature, concentration, presence of other ions and dielectric constant of the medium affect the values of λ_i , should make it possible to predict the actual conductivity and transport numbers that will be found for any solution under a specific set of conditions. Although the application of current views on the natures of ions, solvent molecules and their interactions to the problem of predicting the behavior of λ_i is in most cases too complex for theoretical treatment, very successful approximations have been made for certain limiting cases in the well known modern theories on the physical chemistry of electrolytic solutions (1).

It seems not unlikely, therefore, that the study of molten electrolytes, which lack the complicating presence of solvent molecules, should lend itself to a corresponding theoretical approach. An adequate theory of this type should contribute much to the building of a more comprehensive picture of the nature of liquids in general.

The first step in developing such a theory is to collect data on specific fused salts which will give some insight into the general behavior of molten electrolytes. Although a great deal of conductivity data has already been reported, very little information on transport numbers was available at the time the present work was undertaken. A brief reflection on the nature of the problem of measuring transport numbers in fused salts quickly brings to light the reason for this lack of information. The absence of a solvent, serving as a frame of reference with respect to

which the mobilities of the ions are normally compared, renders meaningless for molten salts the definition of transport numbers as applied to aqueous electrolytes. This becomes clear when it is recognized that λ_i can only be a relative quantity, and hence remains undefined in the absence of a suitable reference frame. Since the previous workers who attempted transport number measurement have apparently ignored this fact, attributing their difficulties to experimental problems, their work frequently suffers from a failure to comprehend the nature of the problem. Those who did see the real problem, on the other hand, have felt it to be a hopeless one, and have generally dismissed the concept of transport numbers in pure fused salts as meaningless.

The problem have undertaken thus resolved itself into two parts. First, a definition of transport numbers was sought which would divide the conductivity of a molten salt into individual ionic conductances in such a way that the values of λ_i thus defined would be unique properties of the salt, depending specifically on the natures of the ions and their interactions. Second, methods of measuring transport number both in pure salts and in mixtures were sought which would be consistent with this definition. Although a general theory to explain the results obtained could not possibly be evolved from a limited study of this kind, it was nevertheless hoped that the data might be subjected to some degree of microscopic interpretation.

II. A DEFINITION OF TRANSPORT NUMBERS IN FUSED SALTS

Before a critical review of the available literature on the subject is possible, it is important to introduce the definition of transport numbers in fused salts that was finally decided upon. This will make it possible to determine to what extent the work to be reviewed is consistent with the present work.

Considering the transport process from a macroscopic point of view, it would appear that the positive ions move in the direction of the cathode with a continuous uniform velocity at any given current density, while the negative ions approach the anode in the same manner. It is this viewpoint that makes the search for a reference frame within the liquid itself appear to be a hopeless one. For, if the negative ions are chosen as the reference, the positive ions must carry all the current, while relative

to the positive ions the negative ions have unit transport number. Thus neither of the constituents of a pure binary salt makes a satisfactory reference frame. In order to find a suitable definition consistent with this macroscopic picture of ionic migration it is therefore necessary to go outside the liquid and seek an external reference.

Perhaps the first such point one might select is the electrode surface. Suppose, for example, molten lead chloride is electrolyzed between lead electrodes. As the anode dissolves in the salt, an equivalent amount of lead is deposited at the cathode, so that the surfaces remain the same distance apart, provided they have equal areas. If the transport numbers are taken as the fractions of current carried by the ions relative to these surfaces, it is apparent that the chloride ions carry no current at all. For the number of chloride ions in a volume of liquid adjacent to the electrode surface remains constant due to the requirement of electrical neutrality throughout all parts of the liquid. The lead ions, on the other hand, enter the liquid at the surface of the anode and are removed at the other side, so that they must carry all the current. If chlorine electrodes are used, however, a similar reasoning leads to the conclusion that the transport number of the chloride ions must be unity, the lead ions carrying no current whatever. Clearly the electrode surfaces do not provide a suitable reference frame, since they define transport numbers which depend only on the electrode processes.

An ideal situation might be visualized which would allow the defining of significant transport numbers consistent with the approach presented thus far. Consider an ionic liquid subject to neither gravitational nor atmospheric restoring forces, so that its surface is not constrained to lie flat and horizontal. The electrolyte between the electrodes is contained in a tube, but has no tendency to flow through the tube as the quantity of salt builds up or decreases around the electrodes. The transport numbers could now be defined as the fractions of current carried by the ions relative to a stationary cross-section of the tube. Although the quantities thus defined depend to some extent on the nature of the interactions between the ions and the surface of the tube, they would at least be more meaningful properties of the liquid than any of the "transport numbers" thus far defined.

The experimental impossibility of the above definition necessitates the search for a more practical one. It should

be obvious at this point that the macroscopic picture of ionic migration presented above does not lead to a suitable working definition of transport numbers in fused salts. One might justifiably conclude that if the transport process involved only the uniform motion of all the cations in the opposite direction from the uniformly moving anions, it would be impossible unequivocally to ascribe a certain fraction of the total current to a particular ionic species. A more realistic view of the mechanism of the conductivity process is therefore required.

The usual picture of ionic migration in accord with modern theories of rate processes (2) presents the ions as moving in short jumps and in a very erratic way. According to this microscopic picture, only a very small fraction of the ions in the liquid are moving at any given instant, these being the ions which have the necessary free energy of activation for migration. The actual number of such current carriers is a function of the temperature and of the potential gradient, but is always a small fraction of the total at normal working temperatures and voltages. It is thus possible to distinguish two types of ions in the liquid, besides the obvious distinction between positive and negative; those ions which are jumping, and those ions which cannot jump because they lack the necessary energy. If the former are called the current-carrying ions, then the latter become the long sought reference frame. For it is surely the way in which the ions move relative to this great inert bulk of the liquid that is required in order to express the conductivity of the salt in terms of meaningful individual ionic conductances.

The transport number of an ionic species, t_i , in a fused salt will therefore be defined as the fraction of the current carried by those ions of i which are jumping measured with respect to that large group of ions of all species present which are at rest relative to each other. Strictly speaking, of course, the transport numbers will subsequently be defined in terms of the experiment by which they are measured, but the experiment will be set up in such a way that the measured quantities should be consistent with definition presented here.

III. REVIEW OF PREVIOUS WORK

Although the literature in the field of transport numbers in fused salts is scant, it extends over a great many

years and includes some papers of unquestionable significance. As mentioned earlier, however, some of the work suffers from a failure of the authors to comprehend the problems introduced by the removal of the solvent reference frame. Although in none of the previous papers has the question of a suitable definition been adequately discussed, the authors' intuitive notions of what was wanted led them in some cases to measure quantities consistent with the transport numbers here defined. These cases will be the chief concern of the present discussion.

The earliest quantitative determination of transport numbers in fused salts was carried out by Lorenz and his co-workers (3) in 1907. These workers studied various mixtures of PbCl_2 and KCl by electrolyzing the melts between carbon electrodes in a specially designed cell. The important feature of this cell is that the anode and cathode compartments are separated by means of a porous clay membrane. This permitted Lorenz to weigh and analyze each compartment separately both before and after electrolysis with a known quantity of electricity. Making careful allowance for the changes in weight of the salt due to absorption into the membrane pores, absorption into the electrodes, and evaporation from the surface, Lorenz presented his corrected data in the form of the following table (3, p. 47):

Table 1.

Transport data of Lorenz

PbCl_2 (weight %)	a-Quantity of Pb deposited in g.	m_1 -Quantity of Pb in catholyte before experiment	m_2 -Quantity of Pb in catholyte after experiment	v-Decrease in Pb in cathodic chamber	v:a
95.72	1.3005	36.4561	35.5145	0.9416	0.7240
88.04	1.2495	28.0543	26.9431	1.1113	0.8893
78.89	1.2998	17.5062	16.1660	1.3402	1.0311
78.64	1.2840	16.3221	14.9801	1.3419	1.0451
64.83	1.2978	15.6483	14.1745	1.4668	1.1279
47.83	1.2629	12.5315	10.5109	2.0206	1.5999

Lorenz pointed out that when the ratio $v:a$ given in the last column exceeds unity, this means that the number of lead ions lost from the cathode chamber during electrolysis exceeds the number of lead ions deposited at the cathode. The implication is, of course, that some of the lead ions have migrated into the anode compartment. This could only be possible if some of the lead were tied up with chloride in such a way as to form complex anions. Since the exact concentrations and formulas for these ions could not be known, the authors were unable to calculate transport numbers for them, and therefore presented their data in the manner indicated.

It is clear that the experiments described measure the way in which the ions move relative to a porous membrane saturated with the salt. It now becomes important to decide whether the transport numbers defined by such an experiment are consistent with the definition presented in the previous section. It is instructive to consider first how a pure salt, such as $PbCl_2$, would behave in an electrolytic cell that had no porous membrane separating the compartments. For the sake of simplicity assume both electrodes to be of lead metal. Every z faradays of electricity passed during the course of electrolysis causes z equivalents of lead ions to be discharged at the cathode, and an equal number to be added to the anolyte. The charge is carried through the liquid by the migration of t_+ equivalents of Pb^{++} into the catholyte, and t_- equivalents of Cl^- into the anolyte. Since $1 - t_+ = t_-$, the net result is thus a transfer of t_- equivalents of $PbCl_2$ from catholyte to anolyte. Recalling that the reference frame selected here is actually a part of the liquid itself, it is clear that this frame will not remain fixed with respect to an observer as the salt is depleted from one side and accumulates on the other. It must move under gravity by the process known as viscous flow in such a way that no change of levels is observed. The importance of the membrane used by Lorenz now becomes apparent. It is designed to prevent viscous flow, while permitting the electrolytic migration of the ions. Its use will therefore permit the measurement of the transport numbers, provided two conditions are fulfilled: (a) the rate at which the accumulating salt flows back through the membrane is negligibly small compared with the rate of its accumulation; and (b) the rates at which the ions jump relative to the liquid within the membrane are the same as in the bulk of the liquid, far from any possible influence of surface properties. Other than the qualitative observation that the membrane seemed to support a difference in

levels without appreciable flow taking place, Lorenz made no attempt to justify its use in terms of these criteria. It was therefore impossible to evaluate the validity of this method on the basis of the data presented. The significance of the work, as well as that of the other papers to be reviewed, will be discussed later in the light of the work to be presented here.

Tverdovskii's method (4) of measuring transport numbers in carnallite, $KClMgCl_2$, made use of a similar principle. Instead of being separated by a porous partition, however, the electrode compartments consisted of glass tubes drawn out to fine capillaries at the bottom, where they dipped into the melt. Again the purpose of the constrictions was to prevent viscous flow, while permitting ionic migration. This author also failed to justify the use of such a procedure. He reported, nevertheless, that magnesium apparently carries current in the form of a complex anion. Assuming the formulas for the current-carrying species to be K^+ , Cl^- , and $MgCl_3^-$, Tverdovskii's data yielded transport numbers for these ions of 0.2, 0.6, and 0.3, respectively.

A modification of the above method was employed by Shcherbakov (5) in studying the same melt. The tubes which formed the electrode compartments were pressed tightly against a glass plate immersed in the salt. This was again designed to prevent backflow, while permitting the passage of current between the ends of the tubes and the surface of the plate. Shcherbakov's results, although very erratic, were apparently in disagreement with those of Tverdovskii (4). Shcherbakov reported that the magnesium behaves as a cation, carrying anywhere from 2 to 50% of the current.

The first attempts to measure the transport numbers of the ions in pure fused salts were carried out by Karpachev and Pal'guev (6) on molten lead chloride. These workers separated the electrode compartments by means of a plug of tightly packed shredded asbestos. Making allowances for the weight of salt soaked up by the membrane, they measured the changes in weight of the compartments before and after electrolysis. They also tried putting some radioactive Pb^{++} in the anolyte and measuring the rate of appearance of activity on the other side of the membrane. Transport numbers calculated from the two types of measurements showed fair agreement, the indicated value of t_- being 0.8. Here again the authors failed to justify the use of the membrane in terms of the possible errors discussed earlier. They did consider the possibility of such errors, nevertheless, and carried out experiments designed to show that the

membrane was not influencing the measured transport numbers. This part of the work unfortunately showed a lack of understanding of the nature of transport numbers in fused salts. It will be discussed shortly, along with some similar papers.

Recent work by Wetmore and his co-workers (7) describes attempts to measure the transport numbers of the ions in mixtures of molten salts by means of a Hittorf-type experiment. The well known Hittorf method (8) for determining the transport numbers of the ions in aqueous electrolytes involves, of course, analysis of the concentration changes occurring around the electrodes during electrolysis. These workers electrolyzed molten mixtures of AgNO_3 and NaNO_3 between Ag electrodes in a cell consisting of two compartments joined by large capillary tube. The purpose of the tube was not to prevent backflow, but merely to reduce mixing of the anolyte and catholyte by diffusion and convection. The anode compartment was drained after electrolysis and its contents analyzed. These data, together with the results of the analysis to determine the composition of the original mixture, were subjected to the following interpretation.

Starting with the equations

$$n_1 = n_1^\circ + z(1 - t_1)$$

$$n_2 = n_2^\circ - zt_2$$

$$t_1 + t_2 + t_3 = 1$$

$$n_2^\circ = N_2^\circ n_1^\circ / N_1^\circ$$

where n_1° and n_2° are the initial numbers of equivalents of AgNO_3 and NaNO_3 , respectively, in the anolyte before electrolysis, n_1 and n_2 the same quantities after electrolysis with z faradays of electricity, t_1 , t_2 and t_3 the transport numbers of the silver, sodium and nitrate ions, respectively, and N_1° and N_2° the initial equivalent (mole) fractions of the two salts in the homogeneous mixture, Wetmore derived the equation

$$t_1 = 1 - \phi - N_1^\circ t_3 \quad (1)$$

where

$$\phi = (N_2^\circ n_1 - N_1^\circ n_2) / z.$$

Equation (1) can also be written in the form

$$t_3 = (\phi - t_2)/N_2^{\circ} \quad (2)$$

by making appropriate substitutions and rearranging.

The important step made in the development of equation (1) was the elimination of the quantities n_1° and n_2° . This made it possible to obtain experimentally an equation in the transport numbers without using a sharply defined anode compartment, by merely draining off sufficient anolyte to include the total concentration change around the anode. Although the equation does not give the exact values of the transport numbers, limiting approximations can be made by assuming that the transport number of each ion lies between zero and one. Thus, it is apparent from equation (2) that $0 \leq t_3 \leq \phi/N_2^{\circ}$, since t_3 has its maximum value when $t_2 = 0$. Substituting these limiting values for t_3 into equation (1), gives $(1 - \phi/N_2^{\circ}) \leq t_1 \leq (1 - \phi)$. It turned out experimentally that for the concentration range studied, $0 < N_1^{\circ} < 0.25$, this expression defined values for t_1 within rather narrow limits. This enabled Wetmore to report that the transport number of the silver ion is very nearly a linear function of its equivalent fraction up to $N_1^{\circ} = 0.244$, at which concentration $0.81 \leq t_1 \leq 0.86$. It should be pointed out that these mixtures represent a particularly fortunate choice, the narrow limits depending on the relatively high value of t_1 at low concentration of AgNO_3 .

Wetmore subsequently applied the same approach to mixtures of AgNO_3 and AgCl (9) again electrolyzed between Ag electrodes. The results obtained did not appear consistent with the assumption that the current is carried only by simple ions, since in order to assign a positive transport number to the chloride ion it was necessary to assume that the nitrate ion carries at least half the current. In view of his results with the AgNO_3 - NaNO_3 system, Wetmore felt the latter assumption to be unreasonable. He therefore suggested that some complex cationic species such as Ag_2Cl^+ takes part in conducting the current.

In reviewing this excellent work of Wetmore, in which one of the chief experimental obstacles to the measurement of transport numbers in mixtures was eliminated, the question naturally arises as to whether the "transport fractions" referred to by Wetmore are consistent with the transport

numbers defined in the previous section. It will be noted that in Wetmore's derivation of equation (1) no mention is made of a reference frame. Careful consideration of equation (1) itself reveals, however, that no reference frame is necessary. That is to say, no matter what frame the transport numbers are referred to, the equation is still valid. If the t 's are referred to some particular reference, changing this frame to some other one merely transforms the equation back into itself. This fact is perhaps most clearly understood when one considers what the result would have been had Wetmore inserted a porous membrane between the compartments to prevent backflow. Since all concentration changes occur at the electrodes, and not at the membrane, any analysis of the anolyte which includes all the change is not affected by the presence of the membrane, unless the concentration change has actually extended back past that point. Thus, provided the nature of the conductivity process is unaffected by the presence of the large liquid-solid interface within the membrane, the experimental analysis will be identical to that obtained in cells without membranes.

The reference frame is, of course, partially fixed when the assumption is made that none of the transport numbers are less than zero. For a simple ionic melt such as the $\text{AgNO}_3\text{-NaNO}_3$ system this assumption seems justified. It is important to keep in mind, nevertheless, that the assumption of simple ionic species is inherent in any calculation of transport numbers which does not include specific allowance for current being carried by complex species, and hence that the results may be misleading when subjected to microscopic interpretation.

The work reviewed thus far consists of papers in which the transport numbers measured may be related, or even identical, to the meaningful transport numbers defined in the present work. Mention should also be made of some of the less constructive approaches to the problem. The purpose is not only to show how confusing the meaning of transport numbers in fused salts has been to some workers, but also to save future reviewers from the task of analyzing these papers.

A series of measurements on molten bromides was carried out by Isbekow (10) in 1926. He electrolyzed mixtures of AlBr_3 with other bromides in a tubular cell which had no partition between compartments. The cathode was a platinum coil in each experiment, the nature of the anode depending on the mixture being studied. For the mixture of AlBr_3

and KBr the anode was an aluminum plate; for the $\text{AlBr}_3\text{-AgBr}$ mixture of silver anode was used; for $\text{AlBr}_3\text{-SbBr}_3$ an antimony plate served as anode. The metal deposited at the cathode in each case was the same as that of the anode material. Isbekow calculated transport numbers by assuming in each case that the AlBr_3 acts as an inert solvent with respect to which the foreign ions carry current. His treatment was thus analogous in every respect to the conventional Hittorf method (8) for determining transport numbers in aqueous solutions, the only difference being the change of solvent. Pure aluminum bromide is known to be a very poor conductor. Although this fact may seem to justify Isbekow's assumption, it seems most likely that solvation of the electrolyte being introduced will give rise to complex species such as AlBr_4^- . This prediction is apparently born out by the results on a mixture containing 12% by weight KBr (equivalent fraction $\text{KBr} = 0.0922$) for which the transport number of the K^+ ion is reported to be 1.14. Application of the treatment developed by Wetmore (7) to Isbekow's data gives $\phi = 1.12$, which shows that the aluminum ion must have a negative transport number. It is interesting to note that the transport numbers calculated by Isbekow come quite close to those calculated from his data by Wetmore's method, provided the assumption is made in the latter treatment that the transport number of the bromide ion is zero. Thus in the case already mentioned, Isbekow's value of 1.14 for t_{K} may be compared with $t_{\text{K}}(\text{max.}) = 1.12$ obtained by the other method, making the indicated assumption. Similarly, for a solution of equivalent fraction 0.0734 AgBr in AlBr_3 , t_{Ag} is reported to be 0.84, while the latter method gives $t_{\text{Ag}}(\text{max.}) = 0.85$. The equivalent fraction of SbBr_3 in the mixture studied was 0.250. Here the value of t_{Sb} reported is 0.95, which can be compared with $t_{\text{Sb}}(\text{max.}) = 0.96$ calculated by Wetmore's method. It should be pointed out that the slight discrepancies are nevertheless real ones, depending not on errors in the calculations, but on the natures of the methods of calculation used.

Although the assumption that AlBr_3 acts as an inert solvent may be at least partially justified, this work of Isbekow seems to have established an unfortunate precedent. For in subsequent studies on NaCl-PbCl_2 and on KCl-PbCl_2 mixtures Antipin (11) and Baimakov and Samusenko (12) used similar cells to calculate even less significant transport numbers. Realizing that lead chloride is too good a conductor to be considered inert, these workers chose such arbitrary frames as the walls of the electrode compartments themselves for reference. Thus, Antipin took great pains to weight the compartments before and after electrolysis,

while Baimakov and Samusenko inferred the initial weights of catholyte and anolyte from a combination of their final weights with the known density of the original mixture. Although the former paper was not available for study and possible analysis of the data by the method described earlier, it appears unlikely that such an analysis would have been fruitful, since the values quoted from this work show irreconcilable deviations (12). The latter study not only showed similar deviations, but reported the data in a way that showed either an inexcusable method of analysis, or a lack of comprehension of the first principles of chemistry. For the figures indicate, in most cases, an excess of the number of cations over the number of anions in the same compartment. Attempts to discover any sort of systematic error proved fruitless, the data apparently contributing nothing whatever to an understanding of transport numbers in fused salts.

The problem of the meaning of transport numbers in pure fused salts was considered by Schwarz (13). He reasoned that the transport numbers of the ions in pure salts must depend on the nature of the electrode processes occurring, the "transport numbers" to which he referred being tacitly defined with respect to the electrode surfaces. Schwarz therefore concluded that the concept of transport numbers in pure fused salts is meaningless. His argument, which is identical to the consideration in the previous section (pages 2 and 3) of the case where transport numbers are defined with respect to the electrode surfaces, was apparently sufficiently convincing that Körtüm and Bockris (14, p. 210) make reference to it in agreeing that transport numbers in pure salts are meaningless.

The work of Karpachev and Pal'guev (6) discussed earlier contains a similar misconception. It was shown that the transport numbers they measured in a cell containing a porous asbestos membrane may be consistent with the quantities defined here. In their attempt to justify the method, however, they measured quantities which bear no relation to these transport numbers. For this experiment they employed a cell in which the compartments were joined during electrolysis by removing a stopper which originally separated them. At the start of the experiment only the anolyte contained radioactive Pb^{++} . By comparing the loss of activity from the anode compartment with that due to convection and diffusion in a similar cell through which no current was passed, the authors calculated the quantity of electricity carried out of the anolyte by Pb^{++} . It is clear that their results, which showed large fluctuations, could have been

calculated more accurately without bothering to carry out the experiments. For, since flow between the compartments was permitted, the transport numbers were defined by the particular electrode processes taking place. In this case the processes involved liberation of chlorine at the anode and of lead at the cathode, so that the transport numbers were 0.5 for each ion with respect to the electrodes. The accumulating lead at the cathode forces some of the liquid to flow back into the anode compartment, however, so that the transport number of the lead ion with respect to the boundary of that compartment is somewhat smaller, depending on the relative sizes of the compartments. The values of t_{Pb} reported by the authors for three such experiments were 0.09, 0.22 and 0.34.

Some confusion as to the reference frame involved is encountered in evaluating the E.M.F. method used by Van Artsdalen and his co-workers (15) to measure the transport numbers of the ions in mixtures of fused salts. It is based on the well known concentration cell method used in aqueous solutions (14, pp. 267-70) wherein the potential is determined with and without a liquid junction between two solutions of the salt having different concentrations, the former potential depending on the transport numbers of the ions crossing the junction. The author's reasoning in this case apparently was as follows. Consider a cell containing two solutions in contact of silver nitrate in sodium nitrate, the silver ion concentration being greater on side A than on side B. The E.M.F. of the cell is measured using silver electrodes in each compartment. This potential is taken to be a measure of the free energy change accompanying (1) the discharge of one equivalent of silver ions at the electrode on side A, (2) the dissolution of one equivalent of silver ions at the electrode on side B, (3) the transport of t_{Ag} equivalents of silver ions across the junction from solution B into solution A, (4) the transport of t_{Na} equivalents of sodium ions from B into A, and (5) the transport of t_{NO_3} equivalents of nitrate ions from A into B. The net result is thus taken to be the transfer of $(1 - t_{Ag})$ equivalents of $AgNO_3$ from a solution in which its mole fraction is N_{1A} to one in which the $AgNO_3$ concentration is N_{1B} , where N_{1A} is greater than N_{1B} , accompanied by the transfer of t_{Na} equivalents of $NaNO_3$ from N_{2B} to N_{2A} , where $N_{2B} = (1 - N_{1B})$ and $N_{2A} = (1 - N_{1A})$. This corresponds to a free energy change of $-(1 - t_{Ag}) RT \ln (N_{1A}/N_{1B}) - t_{Na} RT \ln (N_{2B}/N_{2A})$, provided the solutions are sufficiently ideal that the activities can be taken equal to the mole fractions. If the

process is carried out reversibly, a situation which is very nearly approximated by measuring the reversible potential, this free energy can be equated to the electrical work done in passing one faraday of electricity at the potential of the cell at an infinitesimal rate. This gives

$$E = (1 - t_{Ag}) RT/F \ln (N_{1A}/N_{1B}) + t_{Na} RT/F \ln (N_{2B}/N_{2A})$$

which can be written

$$E = t_{Na} RT/F \ln (N_{1A}N_{2B}/N_{2A}N_{1B}) + t_{NO_3} RT/F \ln (N_{1A}/N_{1B}) \quad (3)$$

by making the substitution $1 - t_{Ag} = t_{Na} + t_{NO_3}$. Since equation (3) contains two unknowns, Van Artsdalen here made the assumption that $t_{NO_3} = 0$, an approximation he felt to have been justified by Wetmore's results (7). The values of t_{Na} thus given by the first part of equation (3) were reported (15) by Van Artsdalen for the same concentration range as that investigated by Wetmore, the "concentration" being taken in each case as the mean of the two concentrations used. The agreement was noted to be poor, since the values of t_{Ag} were substantially smaller than Wetmore's in every case.

Perhaps the most obvious shortcoming of the approach just discussed is the assumption that the transport numbers of the ions do not depend on concentration. In an aqueous solution of a single binary electrolyte this is not too bad an approximation over a limited concentration range, since the concentrations of the two current-carrying species are always identical. A much different situation prevails in the mixture of molten salts under consideration here. For the only way that the concentration of the silver ion can be increased is by decreasing the concentration of its competitor, the sodium ion. The fractions of the current carried by the two ions are therefore almost certain to change, a prediction that is confirmed by Wetmore's data (7).

Assuming that the transport numbers in equation (3) represent some sort of mean value for the two solutions, it again becomes important to decide what reference frame they are being measured with respect to. From the fact that transport from one solution into the other is the only ionic migration considered in the derivation, it is apparent that the reference is the junction between the two solutions. It should be clear that the position of this junction is

defined by the two cations, since the only thing that changes in going from one solution to the other is the ratio of silver to sodium ions. If these two ions have different mobilities, the passage of current will cause one ion to get ahead of the other, so that the position of the boundary will no longer be clearly defined. Thus it is not clear in this case just what the reference is. For the case where both cations have equal mobilities, so that the boundary remains sharply defined, it is easily shown that the transport numbers measured by this method are trivial. For since the cations define the junction between the solutions, the only ions that can cross this boundary are the anions. The reference has thus been chosen in such a way that anions are bound to have unit transport number regardless of their ability to move, the cations carrying no current whatever with respect to themselves. Substituting $t_{Na} = 0$ and $t_{NO_3} = 1$ into equation (3) gives

$$E = RT/F \ln(N_{1A}/N_{1B}). \quad (4)$$

Equation (4) obviously gives the potential that would be found for such a cell under these circumstances, since the net result of reversibly passing one faraday would be the transfer of one equivalent of $AgNO_3$ from solution A to solution B. The above transport numbers are clearly not consistent with those defined in the present work.

Some mention should be made of attempts to infer transport numbers from the values of related experimental quantities. The conductivities of molten salts, for example, were taken as an indication of the transport numbers of the component ions by Bloom and Heymann (16). These workers compared the conductivities of a number of salts at the arbitrarily chosen temperature of 10% above the absolute melting point. In comparing the alkali halides under such conditions, they noted that the equivalent conductivities show a strong dependence on the nature of the cation, but very little dependence on the anion. From this they inferred that the cations probably carry most of the current in these salts. The same considerations applied to a number of di-univalent salts indicated that the singly charged anions take a much more important part in carrying the current. While such inferences are at best qualitative in nature, and a satisfactory justification for the arbitrary choice of temperature has never been advanced, these studies suggest further evidence that the conductivities of

molten electrolytes can be subdivided into ionic components. Such work also helps provide a stimulus for additional research on transport numbers.

A different method of inferring transport numbers has been suggested by Van Artsdalen (15). An equation relating the self-diffusion coefficient of an ion to its conductivity known as the Nernst-Einstein equation (2, p. 556; 17) has been applied successfully both to solid salts and to aqueous electrolytes at infinite dilution. It was felt by Van Artsdalen that the equation should also be applicable to fused salts. On the basis of Berne and Klemm's data (18) for the diffusion of labeled Tl^+ into normal $TlCl$, Van Artsdalen calculated the transport number of the thallium ion in this salt to be 0.94. The applicability of Nernst-Einstein equation to fused salts seems unlikely, however, since its derivation is based on the assumption that the motion of each ion is independent of the motion of other ions, an assumption that can only be valid when the current carriers are relatively far apart. Self-diffusion data for aqueous solutions of $NaCl$ (19), indicate that the Nernst-Einstein equation is not applicable to solutions of electrolytes at concentrations greater than about 0.5 M. This would seem to rule out its use as a method of determining transport numbers in fused salts.

IV. DESCRIPTION AND JUSTIFICATION OF A NEW CELL FOR MEASURING TRANSPORT NUMBERS IN PURE FUSED SALTS

A. Objectives in Designing the Cell

In the light of the discussion in the preceding section it is clear that any direct method for measuring the transport numbers of the ions in pure molten salts must include some provision for preventing viscous flow of the reference frame, i.e., the ions which are not carrying current at any given instant, under a gravitational head. While the use of porous membranes would appear to be most effective for this purpose, such membranes are also most likely to have an effect on the transport numbers, due to the large liquid-solid interface concentrated at the point relative to which the transport numbers are being measured. The approach decided upon for the present research was therefore (a) to develop a practical cell incorporating the use of a porous membrane, and (b) to determine to what extent the use of such a membrane can be justified.

One of the principal experimental difficulties encountered by previous workers was the accurate measurement of the changes taking place within the cell. In weighing the initial and final quantities of salt in each compartment, it was necessary to break open each cell after a single run. Then, allowance had to be made not only for loss due to evaporation from the surface of the liquid, but also for the quantity of salt soaked up by the membrane. These difficulties suggested the use of a cell in which volume changes, rather than weight changes could be measured without removing the cell from the furnace, and in which the surface areas of the two compartments would be equal, so that evaporation errors would be negligible.

It would be impossible to design a cell which would be ideally suited to the measurement of transport numbers in all fused salts, since individual problems are associated with the study of each salt. Thus, for example, it is important to consider such factors as the temperature range to be employed, the nature of the electrodes to be used, the conductivity of the salt, and the stability of the molten salt toward air and moisture. The cell to be described was therefore developed specifically for the study of one salt, lead chloride, $PbCl_2$, being the salt that was selected. The choice was based not only on the highly ionic character of this relatively low melting halide, but also on the fact that the data obtained could be compared with that from the already discussed work of Karpachev and Pal'guev (6). It appeared also that the use of a cell which permitted the measurement of transport numbers in lead chloride could be extended to a number of other salts without serious modification.

B. The Cell and Accompanying Apparatus

The cell shown in Figure 1 proved to be the most practical of a number of modifications tested, all based on the same principle. It is constructed of Pyrex glass and stands about 5 inches high. Of the two horizontal tubes joining the vertical electrode compartments the upper is a uniform capillary of about 2.5 mm. inside diameter, while the lower is about 10 mm. in diameter and contains the membrane which is to separate the compartments. The membrane itself is a Corning fritted glass disk of "ultrafine" porosity.*

*Grading used by manufacturer to indicate relative pore size.

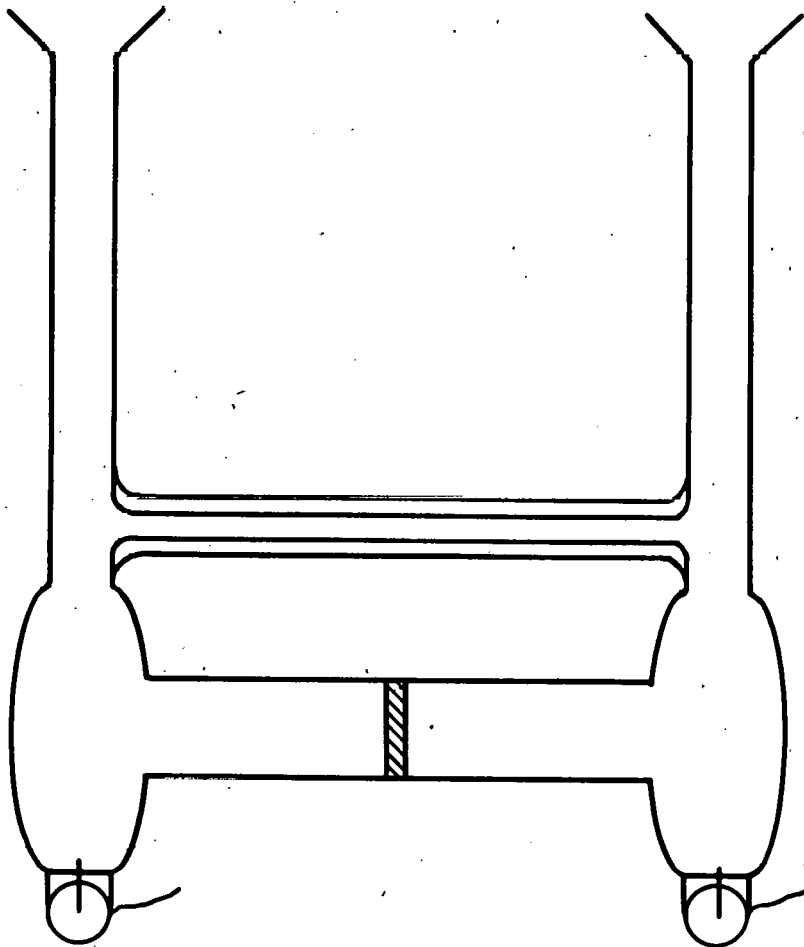

Fig. 1 - Cell for determination of transport numbers
in pure fused salts.

While the over-all dimensions of the cell are not critical it is important that the section of each vertical compartment which extends above the level of the capillary be uniform tubing, except for the flare at the top, of about 6 mm. inside diameter, the two sides being as nearly alike as possible in this region. A piece of tungsten wire is sealed through the bottom of each vertical compartment, from which it emerges into the hollow glass foot underneath. Here the tungsten is fused to a more flexible piece of nickel wire which projects from the cell where it can be connected to a power source. The front of each glass foot is pinched around the emerging nickel wire to help prevent the brittle nickel-tungsten joint from breaking.

The power to operate the cell was supplied in these experiments by a pair of six-volt storage batteries connected in parallel. Currents determined by noting the scale deflection on an accurately calibrated Leeds and Northrup galvanometer connected with known resistors in such a way as to form a reliable ammeter.

A Hoskins electric furnace was used to maintain the cell and salt at the desired temperature. The model employed had small holes through the front and back which permitted the capillary of the cell to be illuminated by a light from behind, and observed from in front with a cathetometer. Temperatures were determined by means of a chromel-alumel thermocouple, the tip on which was located near the center of the cell.

C. Experimental Procedure

Sufficient molten lead was added to each compartment of the cell to form pools which covered the tungsten wires and thereby served as lead electrodes. Care was taken to prevent atmospheric oxidation of the lead, either by melting it under nitrogen, or by dropping solid pieces of lead into molten lead chloride. The remainder of the cell was filled to a point just above the level of the capillary with fused lead chloride. This was done in such a way that an air bubble about 0.5 cm. long was trapped in the horizontal capillary. The appearance of the bounding surfaces of this bubble, when viewed through the telescope, indicated that there would be no tendency for any liquid to flow around the bubble, and hence that the bubble would move along with the column of liquid in the capillary.

On passing a current of about 0.5 amp through the cell, the bubble was observed to move slowly in the direction of the cathode compartment. The rate of this motion was measured in the following way. As the trailing edge of the bubble passed the vertical crosshair of the cathetometer, a timer was started and the exact current noted. About 0.5 g. of powdered lead chloride was then weighed out onto a deflagrating spoon. This was inserted into the oven and emptied into the flared top of the cathode compartment, causing the bubble to move rapidly back to the other side of the crosshair. As the trailing edge of the bubble arrived once more at the crosshair, the timer was stopped. The current was again observed and the exact time of the run noted. Such an experiment took about 700 seconds.

During each run the temperature was also noted. After two or three such runs the direction of current flow was reversed. This procedure could be continued as long as the level of the liquid in each vertical compartment remained within the uniform section of the column.

D. Calculation of Transport Numbers from Experimental Data

The equation relating transport numbers to measured experimental quantities is derived as follows. The assumption is first made that the only current-carrying species in the melt are Pb^{++} and Cl^{-} . The passage of z faradays of electricity thus brings about the transfer of zt equivalents of $PbCl_2$ from catholyte to anolyte accompanied by the transfer of z equivalents of lead from anode to cathode, as shown in the discussion on pages 6 and 7. Letting d_{PbCl_2} and d_{Pb} be the respective densities of the two liquids, this amounts to a transfer of $\left[(zt \times \text{eq. wt. } PbCl_2 / d_{PbCl_2}) - (z \times \text{eq. wt. } Pb / d_{Pb}) \right]$ cc. of liquid from cathode to anode compartment, so the bubble must be displaced by an equal volume in the direction of the cathode. Since the bubble is in the same place at the beginning and end of one experiment, the salt added to the cathode compartment during the run must have exactly nullified this displacement. And since both compartments are of the same diameter and uniform at the surface of the liquid, one half the volume of the added liquid must flow through the capillary from the cathode toward the anode compartment in causing this counter-displacement of the bubble. The former volume may therefore be equated with one half the latter:

$$\frac{z t \times \text{eq. wt. PbCl}_2}{d_{\text{PbCl}_2}} \quad \frac{z \times \text{eq. wt. Pb}}{d_{\text{Pb}}} \quad \frac{1/2 \text{ wt. PbCl}_2 \text{ added}}{d_{\text{PbCl}_2}}$$

Solving for the transport number gives

$$t_- = \frac{\frac{\text{wt. PbCl}_2 \text{ added}}{2z} + \frac{\text{eq. wt. Pb} \times d_{\text{PbCl}_2}}{d_{\text{Pb}}}}{\text{eq. wt. PbCl}_2} \quad (5)$$

Experimentally it was found that the current remained very nearly constant during the course of a run, usually showing a slight drift in one direction. In view of this, an accurate measure of the number of coulombs passed was obtained by merely taking the product of the time and the average current. The ratio R_{PbCl_2} of (wt. PbCl_2 added)/(coulombs passed) determined in each experiment should be a constant. Multiplication of R_{PbCl_2} by $96,500/2$ gives the first term of the numerator in equation (5).

In principle it should be possible to measure the ratio of densities required in the second term using the same cell. Thus, if lead were added to the cathode compartment instead of lead chloride, a new ratio R_{Pb} would be obtained. The desired density ratio would then, of course, be given by

$$\frac{d_{\text{PbCl}_2}}{d_{\text{Pb}}} = \frac{R_{\text{PbCl}_2}}{R_{\text{Pb}}}$$

It was found, however, that addition of lead gave results of poor reproducibility, due to the tendency of the metal to cling to the glass and oxidize there, rather than run freely into the melt. Comparison of the density ratio obtained in this way nevertheless showed good agreement

with literature values, but considerably poorer accuracy. Density figures in the literature were therefore used in calculating the transport numbers of lead chloride to be reported here (20,21).

The transport number of the chloride ion in PbCl_2 calculated by the above method from data obtained with the cell described is 0.758 ± 0.014 at 565°C . It should be pointed out that if it could be shown that the current is actually carried by complex ions of known formulas, the data could readily be reinterpreted in terms of the entities involved. If, for example, the anions were PbCl_3^- , the same reasoning as used above would lead to the conclusion that t_- equivalents of $\text{Pb}(\text{PbCl}_3)_2$ are transferred from catholyte to anolyte for each faraday passed. The only change in equation (5) would be the substitution of eq. wt. $\text{Pb}(\text{PbCl}_3)_2$ for eq. wt. PbCl_2 , so that the actual value of t_- would be one-third of the value calculated on the assumption of a simple anion.

E. Effects of Experimental Variations

1. Quantity of added salt

The quantity of salt added during the course of a single run was varied from less than 0.1 to more than 2 g. Since these experiments were all run at about the same current, this meant that the time of the run also varied over more than a twenty-fold range. The data showed no change in R_{PbCl_2} with these variations, all the values obtained lying within the experimental error.

2. Cell dimensions

The dimensions of only two parts of the cell appeared to be important. These are the diameter of the horizontal capillary and the diameters of the vertical compartments above the level of the level of the capillary. The latter must be small enough so that a small increase in the volume of liquid in one compartment causes the level to rise appreciably, since the hydrostatic pressure difference between the compartments depends only the difference in levels. It was found that tubes as large as 13 mm. in diameter did not permit sufficient head to form for accurate results. If the tubes are too small, on the other hand, surface effects may hinder rapid equilibration of the levels. The 6 mm. tubing finally selected was small enough so that the

bubble would move on addition of a few milligrams of salt, but large enough so that no appreciable capillary rise of the molten salt could be observed in the tube.

The importance of uniformity of these tubes was shown in the discussion of the method of calculating results. In practice it was found that reversal of the direction of current flow sometimes gave appreciable differences in the value of R_{PbCl_2} . Changing the direction frequently and averaging the results, however, always gave values in good agreement with previous work, so that absolute symmetry of the cell of this part of the cell is not essential.

The horizontal capillary must be large enough so that the column of liquid containing the bubble moves easily and smoothly under a small pressure gradient. When a 2.0 mm. capillary was used, the movement of the bubble was observed to be jerky and irregular. The measured values of R_{PbCl_2} for the cell containing this capillary were found to be quite erratic. The bubble movement with the 2.5 mm. capillary, on the other hand, appeared much smoother, the measured results being considerably more reproducible. Changing to a 2.7 mm. capillary brought about no further improvement in the results.

3. Temperature

Most of the experiments on lead chloride were carried out at a temperature of about 565°C. Changing the temperature changes the density ratio of lead chloride to lead, so that a different value of R_{PbCl_2} is to be expected even if the transport numbers remain unchanged. This change of density ratio was the only apparent effect when the temperature was raised to 635°C. The value of t_- measured at the higher temperature was 0.757 ± 0.009 for seven experiments, which can be compared with 0.758 ± 0.014 for twenty-two experiments at 565°C.

The use of Pyrex for a cell of this type is not practical at temperatures above 600°C, since the glass becomes so softened that the cell begins to deform. Attempts to adapt Vycor or quartz to this use bring in additional experimental problems, such as the difficulty of sealing tungsten wires through these materials and the difficulty of obtaining fritted disks of the proper porosity. For this reason the present work was not extended to higher temperatures.

4. Porosity and material of the membrane

Six different membranes were tested to determine the effect of changing the pore size and the material of which the membrane is constructed. The results indicated a dependence on pore size for pores of greater than a certain minimum diameter. Provided the pores were small enough, however, no dependence on the chemical nature of the membrane material could be detected. The specific data are shown in Table 2.

The coarse, medium, and fine porosity membranes were already available in the form of Pyrex sealing tubes. The center section of the cells containing the other three membranes had to be made especially for this purpose. Thus a Pyrex Buchner type funnel containing an ultrafine porosity fritted disk was converted into such a tube. The average pore diameters quoted by the manufacturer (22) for these four disks are 40-60 microns, 10-15 microns, 4-5.5 microns and 0.9-1.4 microns, respectively. The asbestos plug was made by packing finely shredded wet asbestos against a coarse porosity disk in a tube, drying, and sealing another disk on the other side. A circular piece was cut from an unglazed plate and sealed into a tube to form the procelain membrane.

It will be seen from Table 2 that the results obtained with the latter three membranes show excellent agreement among themselves, all lying within the same range of experimental error. The values for the first three membranes are all smaller, progressing downward as the pore size becomes larger. Cases in which the bubble failed to move even when a "fine" porosity disk was used are discussed in the section immediately following.

5. Strength of current

In the investigation of the cell containing the coarse porosity membrane it was noted that addition of a small quantity of salt to one side of the cell caused the bubble to move rapidly in the opposite direction. Passage of current through the cell nevertheless caused no detectable movement of the bubble. It thus appeared that movement of the liquid in the capillary was more rapid than flow through the membrane under a large hydrostatic head, while the latter process was more rapid under a small one. Since the rate of flow of a liquid through a constriction should always be directly proportional to the head, this apparently paradoxical result could only be explained by assuming that the liquid containing the air bubble in the capillary had a

Table 2

Summary of results of transport number experiments on fused PbCl_2 at 565°C using various membranes

Membrane	No. of expts.	$R_{\text{PbCl}_2} \times 10^3$ (avg.)	Avg. deviation of R_{PbCl_2}	t_- (avg.)
"Coarse" porosity ^a fritted glass disk	1	0 ^b	-----	0.336
"Medium" porosity ^a fritted glass disk	11	0.958	+0.045	0.669±0.016
"Fine" porosity ^a fritted glass disk	26	1.079	+0.048	0.711±0.017
"Ultrafine" porosity ^a fritted glass disk	22	1.213	±0.039	0.758±0.014
Asbestos packed between two "coarse" porosity ^a disks	20	1.165	+0.060	0.742±0.020
Porcelain disk cut from unglazed plate	25	1.190	±0.064	0.750±0.022

^a Grading used by manufacturer to indicate relative pore size.

^b Bubble did not move.

certain inertial resistance to flow which was greater than that for the liquid in the membrane. In view of the failure of the bubble to move in transport experiments using the coarse membrane, backflow through the membrane seemed a likely explanation for the low results obtained with the medium and fine porosity disks as compared with the other three results. The above reasoning therefore suggested that at low enough currents, for which the rate of accumulation of liquid in one side is very slow, the bubble might also fail to move in cells containing the latter two membranes.

This prediction was verified when it was found that the bubble failed to move in the cell containing the fine porosity disk at currents below about 0.075 amp. At currents slightly above this level, nevertheless, the value of R_{PbCl_2} was not appreciably different from the value obtained using a current ten times as strong. It was also observed that no such lower limit could be found for the cell containing the ultrafine porosity disk.

F. Validity of Transport Numbers Measured by This Method

The data presented in Table 2 show that the average deviation of R_{PbCl_2} is generally around $\pm 5\%$. At first glance this may not appear to be very good reproducibility for experiments in which the quantities actually measured, the current, the time, and the weight of salt added, can be determined with considerably greater accuracy. When it is realized, however, that the addition of 100 mg. of salt to one compartment changes the difference in levels by less than 1 mm., the experimental precision is seen to be remarkably good. A possible source of error might be the tendency of some of the added salt to cling to the walls of the cell above the melt. The precision of the results would seem to indicate, however, that the quantity of salt thus retained by the walls does not vary significantly from one run to the next.

Precise control of the temperature was not a major factor in these experiments. It is likely that appreciable temperature gradients existed within the cell itself, since such gradients are almost certain to be present in a muffle furnace with a large cavity at such elevated temperatures. The demonstration of the lack of dependence of the transport numbers on temperature over a 70° range indicates that

such thermal gradients cannot be considered a source of error in these experiments.

It was pointed out in the literature review that the use of membranes in the measurement of transport numbers has never been justified by previous workers. The important sources of error to be considered are the possibility of backflow and the influence of the liquid-solid interface in redefining the transport numbers. It is instructive to consider how each of these might be expected to affect the data in changing from one membrane to another.

If some of the accumulating liquid flows back through the membrane, it is clear that the measured value of R_{PbCl_2} will be low. That this is indeed the cause of the first three low results in Table 2 was demonstrated by the failure of the bubble to move even with the fine porosity fritted disk at sufficiently low current. The extent of such backflow, should depend not only on the diameters of the pores, but also on their shape and length. Although the latter factors must certainly have been very different in the ultrafine fritted glass, the asbestos, and the porcelain membranes, the results in all three cases were identical within the experimental error. Coupling this fact with the lack of current dependence demonstrated for the ultrafine porosity membrane seems to justify the conclusion that backflow did not cause appreciable errors in these experiments.

A similar argument seems to rule out the presence of interfering surface effects. Such effects would be expected to show a strong dependence not only on the size and shape of the pores, but also on the chemical nature of the inside surfaces of these pores. For example, a surface that adsorbs positive ions more readily than negative would facilitate the passage of negative ions, thus increasing the apparent transport number of the negative ion. It is well known in the study of related electrokinetic phenomena that quantitative measurements are so sensitive to the chemical nature of the surface that they are difficult to reproduce from one glass capillary to another. The complete lack of dependence of R_{PbCl_2} on the chemical nature of the membrane demonstrated by the data in Table 2 thus seems to prove that surface effects do not play a major part in defining the transport numbers measured by this method.

Additional support for these conclusions comes from two of the papers considered earlier. The membrane used by

Karpachev and Pal'guev (6) was an asbestos plug considerably larger than the one used in these experiments. Thus the channels within the former membrane were undoubtedly of different size, shape and length than those in the latter. These workers nevertheless reported a value of about 0.78 ± 0.03 for t_- , which is well within the experimental error of the value obtained in the present work. The work of Lorenz and Ruckstuhl (3) indicates an indirect confirmation of this value in the following way. The data of Lorenz given in Table 1 (p. 10) can be used to calculate "transport numbers" for Pb^{++} by assuming that only simple ions carry current in the mixtures, regardless of the validity of the assumption. While such transport numbers may not express the actual fraction of current carried by Pb^{++} , they are an indication of what happens to the lead ions during electrolysis. A plot of these transport numbers vs. equivalent fraction $PbCl_2$, is shown in Figure 2, all the data for the mixtures being taken directly from the work of Lorenz and Ruckstuhl (3). It is immediately noted that all but one of the points fall very nearly on a straight line. Adequate justification for the extrapolation of such a line cannot be presented at this time. It does seem significant, nevertheless, that the extrapolated value of t_{pb}

is identical with the value measured in the present work, as is shown in the figure. This would seem to add Lorenz' clay partition to the list of membranes for which the measured value of t_{pb} in $PbCl_2$ is invariant.

The lack of interfering surface effects is indicated by the results of still another experiment. This was the measurement of the temperature dependence of the resistance of a transport cell containing pure $PbCl_2$. Considering electrolytic conductance as a rate process, the temperature dependence of the conductivity of an electrolyte is a measure of the "activation energy of ionic migration" (16). The value of this quantity, denoted here by E^\ddagger , is readily obtained from the following consideration. Let the specific conductivity be expressed in the exponential form that is customarily used to represent the temperature dependence of any rate process (2):

$$K = A_e^{-E^\ddagger/RT}$$

A plot of $\ln K$ vs. $1/T$ should thus give a straight line of slope E^\ddagger/R . Nearly straight lines have been found experimentally for many fused salts (16). This has been taken to

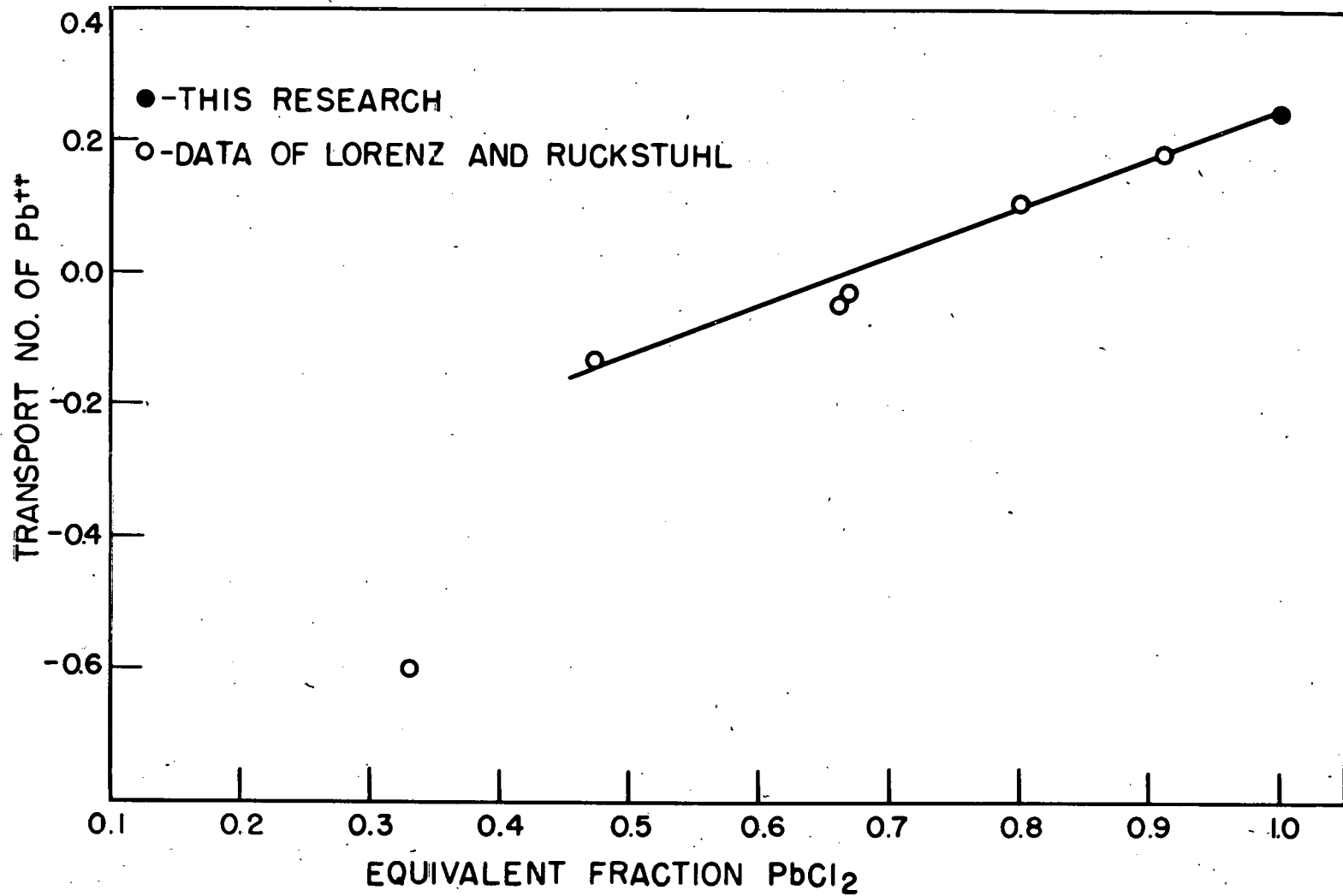

Fig. 2 - Dependence of t_{Pb} on concentration in mixtures of $PbCl_2$ and KCl .

mean that the process of ionic migration in a molten salt can be characterized by an experimental activation energy which is closely related to the heat of activation defined in the theory of rate processes (2). Since the heat of activation is postulated to be dependent on the microscopic mechanism of the process, the experimental activation energy should reflect changes in that mechanism. Thus, if the insertion of the membrane affected the rates of motion of the ions relative to the bulk of the liquid, a change in the activation energy of conductivity might well be expected to accompany this change of mechanism. This would be especially likely if the individual ionic species actually have independent activation energies, so that conductivity can be expressed as a sum of exponential terms:

$$K = \sum_1 A_1 e^{-E_1^\ddagger/RT}. \quad (6)$$

Mathematical analysis of equation (6) for the case where $i = 2$ reveals an interesting consequence which evidently was not suspected by previous workers. The assumption in the past (16) has been that obtaining a straight line from a plot of $\log K$ vs. $1/T$ indicates one of two things about the relative values of E_1^\ddagger and E_2^\ddagger : either they both have the same value, or one is so much greater than the other that the corresponding ion contributes negligibly to the conductivity. It can be shown, however, that there are actually a wide variety of values of the E_1^\ddagger and A_1 for which a plot of $\log K$ vs. $1/T$ gives a curve which is not distinguishable from an experimental straight line over a temperature range of several hundred degrees. The "activation energy" calculated from the slope of such a curve always lies somewhere between the two values of E_1^\ddagger selected, depending on the magnitude of each term as determined by both A_1 and E_1^\ddagger . Since the transport numbers in a pure binary salt should be a measure of the relative weights of the two terms, any alteration of the transport numbers should cause a corresponding change in the experimental activation energy of conductivity.

The results of activation energy determinations on pure PbCl_2 in cells with and without membranes are compared in Figure 2, the data for the latter being taken directly from the work of Bloom and Heymann (16, p. 410). Only the slopes of these lines are to be compared, the absolute magnitude of the former conductivity depending on the unknown cell constant. It should be noted that the experimental procedure

used in the present work was extremely crude compared with the careful work of Bloom and Heymann, who employed an elaborate system of temperature control (16). The data for the cell with the ultrafine disk were taken by merely measuring with a 1000 cycle conductivity bridge the resistance of a typical transport cell (Figure 1, p. 10) filled to a level below the capillary with pure PbCl_2 and standing in the muffle furnace. The temperature measured by the thermocouple was thus that of the air in a region immediately outside the cell, the assumption being made that this was also the temperature of the salt within the disk.* Readings were taken as the oven was allowed to cool slowly, so that thermal equilibrium was not really established. The slopes of the two lines shown in Figure 3 nevertheless show good agreement, the calculated activation energies lying within 0.5 kcal. Since this sort of precision is seldom exceeded for such measurements, except in the most carefully controlled experiments, it can be stated that the presence of the membrane leaves the activation energy of ionic migration unchanged within the experimental error.

Still another factor remains to be taken into consideration in justifying the use of the cell described for measurement of transport numbers in fused salts. This is the possible influence on the measured transport numbers of metal from the electrodes dissolved in the salt. While the exact nature of the solutions formed is not yet well understood, the qualitative observation is that the color of normally yellow molten PbCl_2 , for example, is changed almost to black at temperatures above 600°C by the addition of the metal. Reports of quantitative determinations of the extent of this solubility vary, but the most recent work of Corbett and von Winbush (23) indicates that the dissolved metal constitutes less than 0.1 mole per cent of the melt in this case.

To determine the possible effect of dissolved lead metal on the nature of ionic migration in fused PbCl_2 the following experiment was carried out. A transport cell containing a fine porosity fritted disk was filled with pure

*Almost the entire IR drop across the cell occurs within the membrane, the actual resistance of a cell containing PbCl_2 being about 10 ohms.

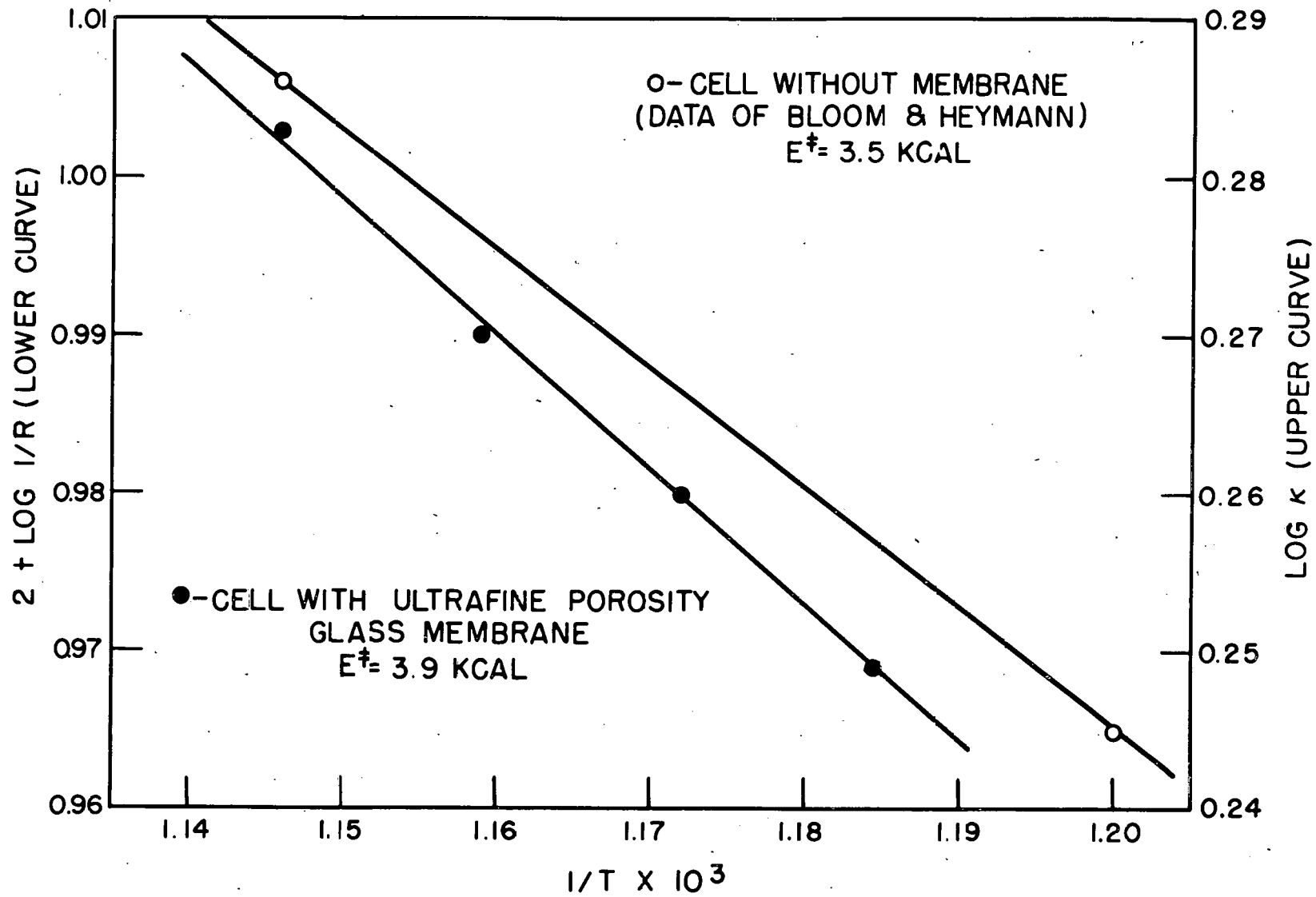

Fig. 3 - Dependence of experimental activation energy of conductivity of pure PbCl_2 on nature of cell.

molten PbCl_2 , so that the tungsten wires served as electrodes. The temperature dependence of the conductivity of this cell was now measured, readings being taken with an accuracy of about one part in three hundred. Following this, the salt was decanted into a beaker containing lead metal. The liquids were allowed to stand in contact at 600°C . until the very dark color of the salt phase indicated probably saturation with the metal. The salt was then decanted back into the cell and its conductivity again measured as a function of temperature. The resistance readings taken at every temperature over more than a seventy degree range were observed to be identical with the values previously obtained for the pure salt within the accuracy of the instrument. The fact that the presence of dissolved metal affects neither the magnitude nor the activation energy of the conductivity of the salt would appear to justify the conclusion that the transport numbers also remain unaffected.

Strictly speaking, the absence of surface effects due to the membrane and the absence of any influence of dissolved metal on the transport numbers should be justified for each particular salt investigated. The above discussion suggests a simple experiment which may be used as a general criterion to indicate the validity of the method for any particular salt under consideration. By comparing the temperature dependence of the conductivity measured in a transport cell containing the electrodes to be used with corresponding data for the pure salt obtained using inert electrodes, it should be possible to decide whether these factors have any influence on the mechanism of the conductivity process. A significant change in the slope of the $\log(1/R)$ vs. $1/T$ curve would probably indicate the inapplicability of the method for the salt being studied.

V. A CELL FOR MEASURING THE TRANSPORT NUMBERS OF THE IONS IN MIXTURES OF FUSED SALTS

The cell described in the preceding section cannot be used for the exact determination of the transport numbers of the ions in a melt containing more than two current-carrying species. Under certain conditions, however, its use should yield an equation in two unknowns which could be solved simultaneously with the equation obtained from experiments of the type carried out by Wetmore (7) to give the exact transport numbers of all three ions in a mixture. The conditions referred to require that the densities of catholyte

and anolyte remain equal above the level of the capillary during the course of electrolysis. Attempts to circumvent this requirement by the use of a modified version of the cell will be described along with the experimental results of transport number measurements on a mixture of AgNO_3 and NaNO_3 , presented in the following section. The present section³ will describe a cell which was developed for the purpose of obtaining in a single experiment the transport numbers of all ions in any experimentally feasible homogeneous mixture of salts.

The transport cell is illustrated in Figure 4. It is considerably smaller than the other cell standing only about 2 inches high. Again the cell is made of Pyrex glass and consists of two compartments separated by an ultrafine porosity fritted glass disk. Tungsten wires sealed through the bottom of each compartment and joined to nickel wires provide contact with the metal electrodes to be used. No feet are necessary, since the cell stands in a sand bath which can be placed directly into the furnace.

The procedure for operating the cell is as follows. Samples of the homogeneous mixture of salts to be studied already ground into a powder are weighed accurately into each of the two sides of the cell, using enough salt to fill it nearly to the top.* The cell is now buried in the sand bath so that sand comes almost to the top of the outside. After placing the bath in the furnace with the tip of a thermocouple buried next to the cell, the temperature is raised to the desired level and the whole system allowed to stand until the temperature inside the bath agrees with the furnace temperature. It should be noted that better temperature control is desirable in these experiments in order to cut down mixing of the electrolyte by convection and diffusion under a temperature gradient. If the activation energy of conductivity criterion for the validity of the method discussed in the preceding section is to be used, the measurements should be carried out at this point. To carry out the actual run a known quantity of electricity is passed through the cell. An upper limit on the strength of current that can be used is established by the fact that the fritted disk tends to overheat and fuse together when the electrical energy being expended exceeds about two watts.

*On melting, the liquid levels should not quite reach the top of the center section.

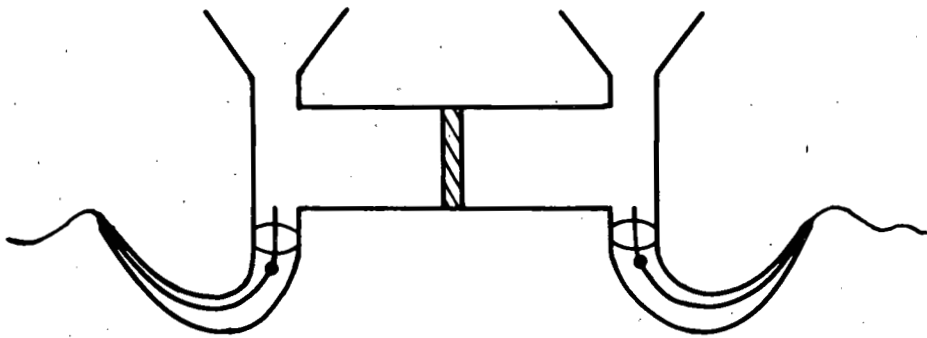

Fig. 4 - Cell for measuring transport numbers in mixtures of fused salts.

When the run is complete, the bath is removed from the furnace and the cell quickly withdrawn from the sand. After cooling the cell is carefully broken at the disk. This is not difficult, since the glass is strained and may already be cracked at this point. The disk is now broken away from the salt on the other side, any adhering salt being carefully scraped into the appropriate compartment. The contents of each compartment are now analyzed for the exact number of equivalents of each ionic species present by a suitable procedure.

The transport numbers are readily calculated from the data as follows. Except for the species changed at the electrodes, the number of equivalents of each ion transferred from one side to the other during the passage of z faradays is given by zt_1 , the direction of the transfer being determined, of course, by the charge on the ion. The corresponding transfer for the ion formed at one electrode and removed at the other is $z(1 - t_1)$ in the direction opposite to that of its migration. To find the actual amounts transferred from the experimental data the total number of equivalents of each ion in the cell, n_{iT} , is first obtained by adding the numbers of equivalents of i in the cathode and anode compartments, n_{iC} and n_{iA} . Division of n_{iT} by the sum of all such terms gives the initial equivalent fraction of i , N_i , in the original homogeneous mixture. The original number of equivalents of i in each compartment, n_{iC}^0 or n_{iA}^0 , is thus given by multiplication of N_i by the total number of equivalents of all ions present initially in that compartment, n_{TC}^0 or n_{TA}^0 . The latter quantities are found by assuming that equal amounts of salt were lost from each compartment by absorption into the membrane and by evaporation before the run was started. The total initial quantity of salt is taken to be the same as the final number of equivalents found in both compartments. The fraction in each compartment initially is given by the ratio of the weight of solid salt put into that compartment originally to the total weight of salt put into the cell. Multiplication of this fraction by the final total of equivalents of all species analyzed thus gives the initial number of equivalents to be taken for each compartment. The transport number of a cation, k , not reduced at the cathode, for example, is given by $t_k = (n_{kC} - n_{kC}^0)/z$, where the quantities on the right are determined by the method just described.

The possibility that errors due to backflow of the liquid through the membrane may be introduced is obviously increased with this cell, since a small difference in levels

will probably exist from the time the salt melts. The qualitative observation that all the salts studied appear to show very little tendency to flow through ultrafine porosity disks seems at least partially to justify the method. For example, a difference in levels of about 1 cm. of AgNO_3 , the least viscous salt studied, showed no apparent decrease on being left in a transport cell at 250°C . (40° above the melting point) for almost a week. If the assumption can be made that the rate of flow with a D.C. current flowing is the same as that with no current, rough calculations based on this observation indicate that the contribution of backflow will be negligible when this cell is used in transport number experiments.

VI. SOME SPECIFIC TRANSPORT NUMBER DETERMINATIONS

The experimental applications of the methods developed that were actually carried out will now be described. The results obtained for four pure fused salts are summarized in Table 3, the details of these experiments being presented on the pages immediately following. Results of a determination on a mixture of salts will also be considered in this section.

Table 3

Results of transport number determinations on four pure fused salts

Salt	Temp. ($^\circ\text{C}$)	No. of expts.	t_- (avg.)
PbCl_2	565	22	0.758 ± 0.014
	635	7	0.757 ± 0.009
PbBr_2	500	11	0.653 ± 0.013
	600	5	0.674 ± 0.003
TlCl	475	3	0.496 ± 0.004
	505	2	0.492 ± 0.001
	525	2	0.493 ± 0.000
AgNO_3	225	2	0.24 ± 0.02
	275	2	0.24 ± 0.02

A. Lead Chloride

1. Materials

Fisher certified reagent lead chloride was used. Further purification did not seem necessary, since small amounts of impurities had no apparent effect on the results. The lead metal used for the electrodes was "Baker Analyzed" reagent grade.

2. Procedure and observations

All pertinent information relating to the study of this salt was presented in the description of the cell, its use and its justification. Papers describing the work have also been published in the literature (24,25).

B. Lead Bromide

1. Materials

Fisher purified lead bromide was recrystallized from 0.1 N HBr. The crystals showed a melting point of 370°C., which identifies them with pure PbBr_2 rather than the substance melting at 480°C. which has often been mistaken for this compound in the past (26). The lead metal again was "Baker Analyzed" reagent grade.

2. Procedure and observations

Pure PbBr_2 melts to a red liquid. Based on the degree of darkening produced by addition of the metal, the qualitative estimate is that the solubility of lead in this salt is somewhat smaller at the temperatures employed than in PbCl_2 . In order to test the validity of using lead electrodes and an ultrafine fritted disk the resistance of the transport cell was measured as a function of temperature. The activation energy found in this way is compared in Figure 5 with that calculated from specific conductivity data for the pure salt given in International Critical Tables (27, Vol. VI, p. 148). The agreement is even better than might be expected, considering the possible magnitude of experimental error.

In spite of the low melting point of this salt, it was not found possible to carry out accurate transport number

measurements at a temperature of about 430°C., since the viscous and surface properties in this region are such that the bubble does not respond readily to a small difference in levels. Warming the salt to 500°C. eliminates this problem, however, so that reproducible results could be obtained at the latter temperature. The average value of R_{PbBr_2} at 500°C. was found to be $(1.395 \pm 0.050) \times 10^{-3}$ for a series of eleven experiments. Combination of this figure with density data in the literature for the salt (28, p. 74) and the metal (21) gives $t_{\text{Br}} = 0.653 \pm 0.013$.

At 600°C. the reproducibility was found to be even better, the average value of R_{PbBr_2} being $(1.498 \pm 0.010) \times 10^{-3}$. This gives a value of 0.674 ± 0.003 for the transport number of the bromide ion at the higher temperature.

C. Thallous Chloride

1. Materials

Fisher purified thallium (ous) chloride was recrystallized from 0.01 N HCl. Spectrographic analysis of the salt revealed no appreciable metal impurities. The metal for the electrodes was Sargent CP thallium metal.

2. Procedure and observations

The solubility of the metal in the salt is reported (23) to be 0.09 mole per cent at 550°C. Figure 6 shows a comparison of the temperature dependence of the conductivity of TlCl saturated with the thallium, measured in a transport cell, with that reported in Drossbach's Elektrochemie geschmolzener Salze (28, p. 73). It will be noted that the former curve showed a very significant time dependence, the activation energy showing an increase of about 7 kcal. after the salt had stood in the furnace for 48 hours. The magnitude of the conductivity showed a corresponding decrease for this period. Analysis of salt taken from the cell at the end this time showed that an appreciable fraction had been transformed into the oxide Tl_2O . Since either hydrolysis with water vapor or exchange of chloride with atmospheric oxygen could account for this change, an attempt was made to reduce both of these factors by passing dry nitrogen through the furnace.

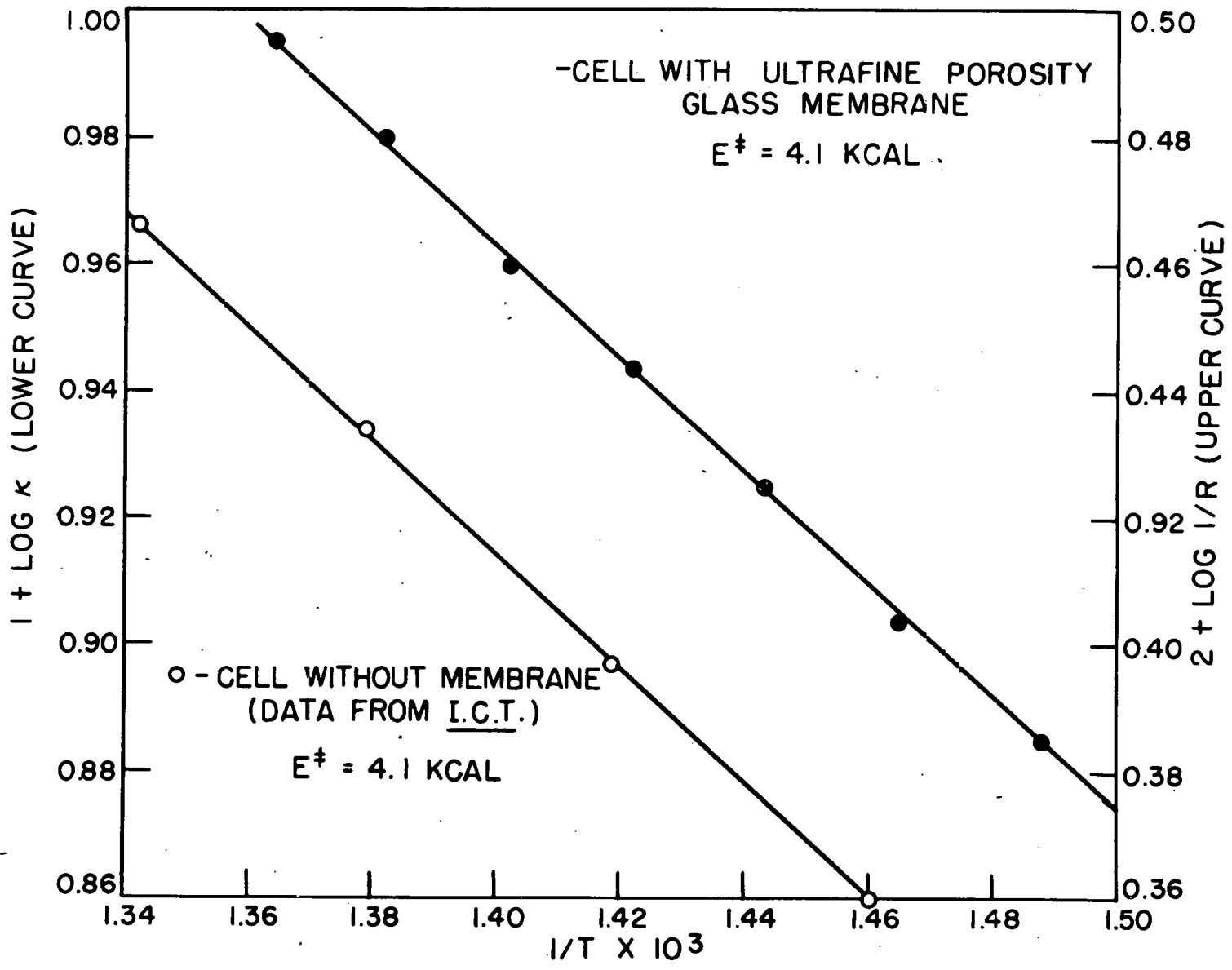

Fig. 5 - Dependence of experimental activation energy of conductivity of pure PrBr₂ on nature of cell.

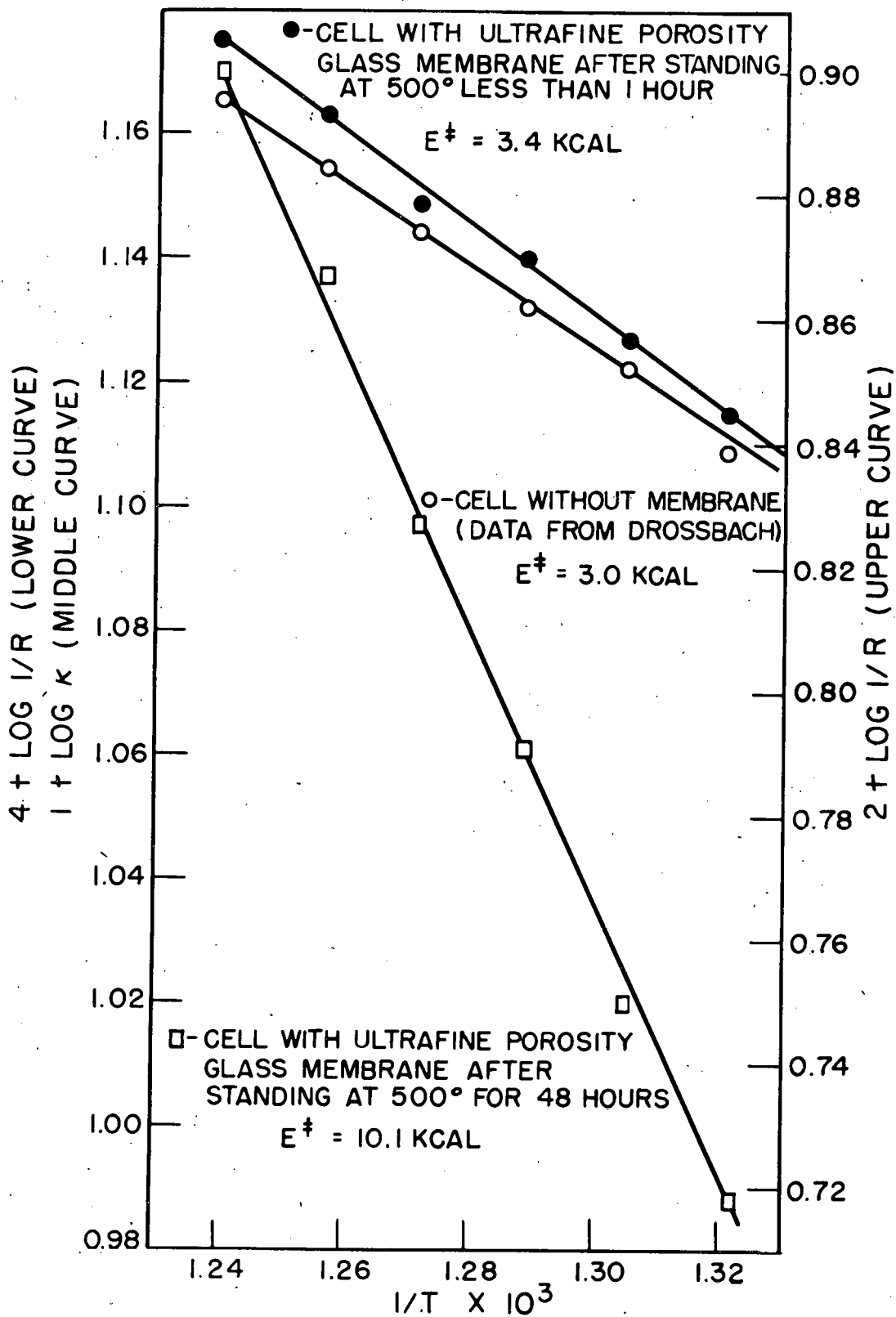

Fig. 6 - Dependence of experimental activation energy of conductivity of pure TlCl on nature of cell and on effects due to standing in air at 500°C . for 48 hours.

In spite of the effort to slow down oxide formation, the measured values of the transport numbers showed a similar time dependence, which was obviously connected with the contamination of the melt. The runs on first filling the cell with freshly purified salt three separate times, however, showed excellent agreement among themselves. Movement of the bubble is very slow for this salt, so that only about two runs could be made each time before the effect of oxide formation on the results began to become noticeable. The latter effect always produced a downward trend in the value of R_{TlCl} eventually reversing the direction of motion of the bubble. Over the 48 hour period for which the change in activation energy is shown in Figure 6 the value of R_{TlCl} at 525°C. fell from $(0.283 \pm 0.001) \times 10^{-3}$ to $-(1.33 \pm 0.07) \times 10^{-3}$. If any significance could be attached to transport numbers calculated from the latter value, this change would correspond to a decrease of 0.33 in the transport number of the anion. It seems reasonably certain, however, that the correct transport numbers for $TlCl$ correspond to the values of R_{TlCl} obtained with the fresh salt, for which the measured activation energy showed good agreement with that calculated from the literature data as is shown in Figure 6.

The calculation of actual values of the transport numbers depends, of course, on an accurate knowledge of the densities of both salt and metal. While the former density figures were available in Conway's tables of electrochemical data (29, p. 281), the latter had to be inferred by linear extrapolation of the data given in International Critical Tables (27, Vol. II, p. 463) for the density of liquid thallium in the temperature range 302 to 353°C. This is perhaps not a bad approximation in view of the relatively small thermal expansion of liquid metals, but it should be pointed out that it is probably this figure which determines the accuracy of the calculated transport numbers. The reason for this is that in the equation relating the transport numbers to experimental quantities (see equation 5, p. 37, for example) the density term turns out to be weighted much more heavily than the term calculated from R_{TlCl} , due to the relatively small value of this experimental number. For measurements on freshly purified $TlCl$ the average values of R_{TlCl} found were as follows: for three experiments at 475°C., $R = (0.284 \pm 0.025) \times 10^{-3}$; for two experiments at 505°C., $R = (0.275 \pm 0.002) \times 10^{-3}$; for two experiments at 525°C., $R = (0.283 \pm 0.001) \times 10^{-3}$. The corresponding average values of t_{Cl} for this salt are 0.496 ± 0.004 , 0.492 ± 0.001 and 0.493 ± 0.000 , respectively, where the indicated error in each case refers only to that part of the measurement carried out in this work.

D. Silver Nitrate

1. Materials

"Baker Analyzed" silver nitrate was recrystallized from water, dried one hour at 110°C., fused at 230°C. for 15 minutes, cooled rapidly, ground to a powder and stored in a desiccator. Silver metal electrodes were plated onto the tungsten wires in the cell from an aqueous bath of the following composition: AgNO_3 - 34 g/l., KCN - 58 g/l., Na_2CO_3 - 5 g/l., KCNS - 20 g/l. The anodes used in this electrolysis were made from Fisher certified reagent silver metal, the process being carried out at room temperature using a current density of about 6 ma/sq. cm.

2. Procedure and observations

The greatest experimental difficulties in the present work were encountered in the study of pure AgNO_3 . A number of innovations were necessary which may be found useful in the application of the method to other salts.

Although pure AgNO_3 melts at about 210°C., the temperature range that can be studied is limited by the rate of thermal decomposition of the salt, which proceeds with fairly rapid formation of bubbles at temperatures much above 300°C. Slow decomposition occurs even below the melting point, but the activation energy of conductivity measured after allowing the molten salt to stand below 300°C. several hours nevertheless showed excellent agreement with careful work reported in recent literature. Specific data are plotted in Figure 7, the literature values being taken from the work of Byrne, Fleming and Wetmore (30). The results in Figure 7 also seem to justify the use of the membrane and of silver electrodes. Here the metal shows no apparently tendency to dissolve in the salt.

The plating procedure for forming the electrodes was found necessary in order to insure that tungsten at the anode is completely coated. If any of the wire is exposed, evolution of gas from the anode is observed during electrolysis. Sealing of silver wires through the glass to circumvent this difficulty was shown to be possible, but very difficult.

Still more trouble was found at the cathode. Electrolysis of molten silver salts produces deposits of the metal which grow out rapidly from the surface of the cathode

414

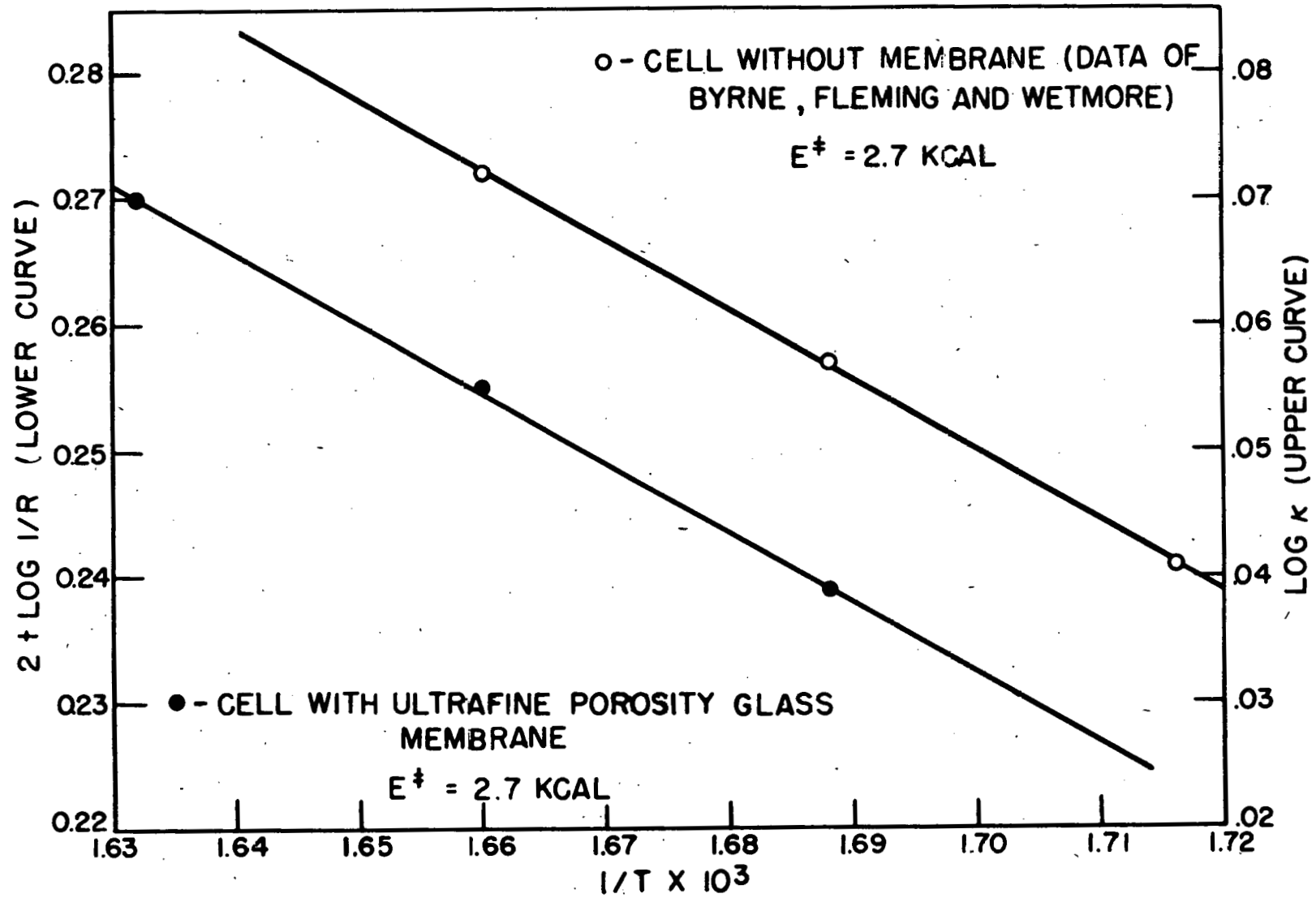

44
ISC-654

Fig. 7 - Dependence of experimental activation energy of conductivity of pure AgNO_3 on nature of cell.

in the form of dendrites, or "trees," as they are commonly called. This presented a serious problem, for by the time a few coulombs of electricity were passed through the cell the trees would have grown right through the membrane and into the anode compartment. It was found possible, however, to greatly alter the nature of the deposit by superimposing a relatively large alternating current on a small pulsating direct current. The circuit with which this was accomplished is shown in Figure 8. The actual currents observed on the ammeter and galvanometer are 360 ma AC and 24 ma DC, respectively, the latter being about one-half that calculated by Ohm's Law (14, p. 9) due to its pulsating nature. The current may be represented by a distorted sine wave, the area under the peaks being slightly greater than that above the troughs. Silver is thus alternately deposited and dissolved at the "cathode" during each of the 60 cycles per second, a little more of the former taking place each time than the latter. The experimental result of this arrangement is that dendrites are much denser and shorter for a given quantity of electricity. It was found that a current of this magnitude could be passed for several hours before the growth reached the membrane.

Even when the arrangement described is employed, the method is subject to further limitations. It is unsatisfactory, for example, below about 820°C., the deposit again growing too rapidly to permit significant experiments to be run. Since the nature of the deposit actually depends on the current density, the size of the electrodes used is also an important consideration. The indicated arrangement is satisfactory for electrodes at least 1 sq. cm. in surface area, provided a sufficiently high temperature is maintained.

Addition of about 10 mg. of the powdered salt to one compartment of a transport cell containing pure AgNO_3 does not create sufficient head to move the bubble. This is apparently due to stronger surface forces maintaining the level of liquid in these tubes, since the viscosity of AgNO_3 is actually less than that of PbCl_2 (31, pp. 1624-5). A modification of the cell was therefore constructed, designed to magnify the effective head produced by a small increase in volume. The new cell was identical to the one shown in Figure 1 (p. 33) in every respect, except that the top of one electrode compartment was fitted with a ground glass stopper. This stopper serves to seal off the compartment, so that no liquid can accumulate or be depleted from that side without movement of the bubble. Assuming the air trapped in the space between the stopper and the liquid to

behave ideally, a simple calculation shows that the effective head produced by adding a given volume of salt to the stoppered compartment is about $500/dh$ times as great as the corresponding head in an unstoppered cell, where d is the density of the salt and h the height of the trapped column of air. It is clear that by filling the cell nearly to the bottom of the taper and inserting the stopper it can thus be made more than 1000 times as sensitive in this respect.

Employment of the modified cell sacrifices two important advantages of the original version. First, the cell can no longer be used as a null instrument, so that accurate calibration of the volume of capillary per unit length and accurate measurement of the distance moved by the bubble become necessary. Second, and more important, the restriction of one compartment to a constant volume means that changes in density due to thermal fluctuations no longer affect both compartments equally. For example, a slight rise in the temperature of the furnace, which would have caused both sides to expand upward about equally in the first cell, now causes the bubble to move in the direction of the unstoppered side. Unless the temperature can be rigorously controlled, the bubble thus acquires a thermal background motion which, of course, is indistinguishable from its motion due to the passage of current. In the case of AgNO_3 still another background motion is superimposed, due to the slow thermal decomposition of the salt releasing bubbles of gas in the sealed compartment. The latter motion is, of course, unidirectional, and is usually sufficiently small and uniform that it can be corrected for in the calculations.

The actual experiments were carried out as follows. After stoppering the cell containing the bubble, the system was allowed to come to thermal equilibrium in the furnace with only the symmetrical AC current flowing. The pulsating DC current was then added, so that only a small heating effect was thereby produced. The position of the bubble at various intervals was noted to the nearest 0.01 cm. with a measuring cathetometer. It was observed that the bubble always moved away from the stoppered side when the current was first started, regardless of the direction of the DC. This was apparently due to the additional heating amounting to about 0.2 watts at the membrane. It took about 1000 seconds for a new equilibrium position to be reached, after which any motion of the bubble that occurred could not be distinguished from the normal background described above. This behavior was the same both at 225 and at 275°C., regardless of the direction of DC current flow. The transport numbers of the ions in pure AgNO_3 thus appear to have

47

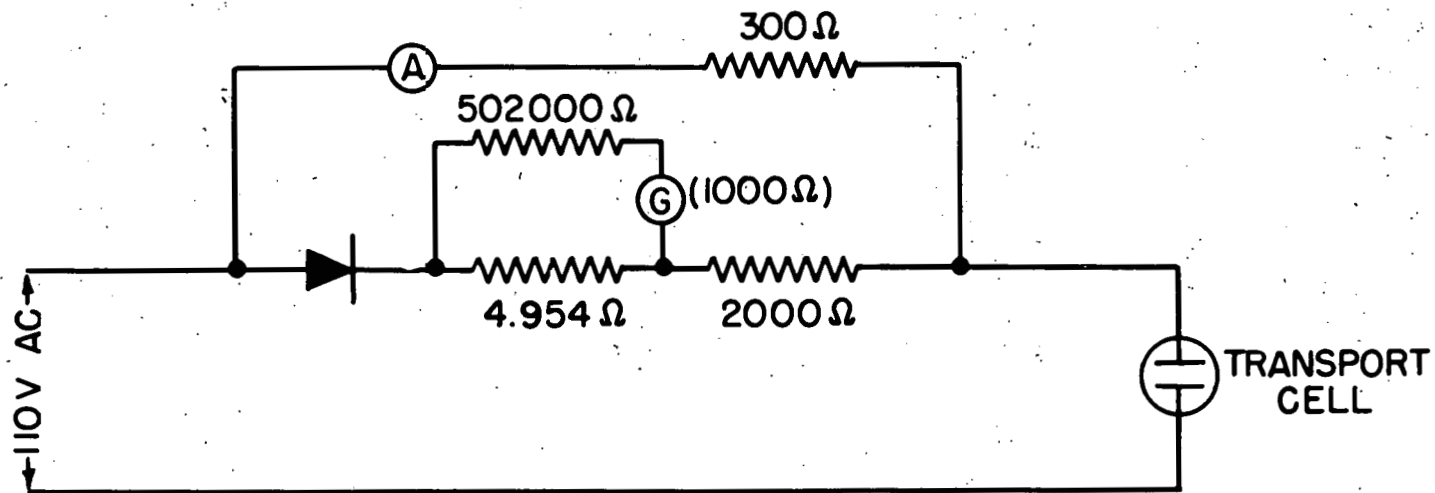

Fig. 8 - Circuit used to reduce tree growth at cathode during electrolysis of fused AgNO_3 .

ISC-654

47

values such that the volume of salt transferred from catholyte to anolyte on electrolysis is equal to the volume of silver metal transferred from anode to cathode. On the basis of density figures in the literature for the salt (30) and the metal (27, Vol. I, p. 103), the transport number of the nitrate ion that would cause such a result is 0.24. In view of the errors discussed, however, the accuracy of this figure is probably not better than ± 0.02 .

E. Equimolar Mixture of Silver Nitrate and Sodium Nitrate

1. Materials

"Baker Analyzed" sodium nitrate was dried for several days at 110°C . Other reagents were the same as those used for the study of AgNO_3 , silver electrodes being plated into the smaller cell shown in Figure 4 (p. 60) in the same manner.

A standard solution of 0.3 N AgNO_3 was made by weighing a sample of the salt, purified as described in the previous section, into a 1000 ml. volumetric flask and diluting to the mark.

"Baker Analyzed" potassium thiocyanate was used to make up a solution about 0.4 N. This solution was standardized against the AgNO_3 solution using ferric ammonium sulfate as indicator.

A 1.1 N solution of NaOH was standardized against primary standard potassium acid phthalate.

"Nalcite" cation exchange resin was charged with 3 N HNO_3 made by diluting Baker and Adamson C.P. nitric acid.

2. Procedure and results

The modified cell developed for use with AgNO_3 was first tested to determine its practicability for use on AgNO_3 - NaNO_3 mixtures. Electrolysis of such mixtures in this cell should cause a transfer of $\left[(1 - t_{\text{Ag}})\bar{V}_{\text{AgNO}_3} - t_{\text{Na}}\bar{V}_{\text{NaNO}_3} \right]$ cc. of

salt from catholyte to anolyte accompanied by a transfer of \bar{V}_{Ag} cc. of silver from anode to cathode for each faraday passed, where the \bar{V}_i refer to the partial equivalent volumes of these substances. From density data for this system (30) it is known that the equivalent volumes are additive over the

whole concentration range, so that these quantities could be used in conjunction with experimental data obtained from the cell to give an equation in two unknowns. This equation could then be solved simultaneously with the one obtained by Wetmore (7) to give the exact values of all three transport numbers. It was found experimentally, however, that thermal fluctuations of the bubble in these dilute solutions of AgNO_3 were much greater than for the pure salt, the resulting background being too large to allow collecting of any significant data. The method was thus inapplicable to the present case, but may yet be found useful for a similar one, e.g., PbCl_2 and KCl . It should be emphasized that it is necessary to use the stoppered cell for such mixtures, since the density changes in the compartments during electrolysis would otherwise give rise to a difference in the levels of the two sides.

Only one attempt was made to apply the method for determining transport numbers in mixtures described in Part V. While this experiment was a partial failure due to inadequate control of tree growth, the results obtained nevertheless seem to demonstrate the usefulness of the method. The following details of the experiment are noteworthy.

The mixture was made up by melting together the two salts in a beaker in the furnace, stirring the liquid thoroughly, and cooling rapidly. The salt was then ground up and three samples taken for analysis. Each sample was dissolved in water which was then passed through the ion exchange column. Titration of the acid liberated with standard base thus gave the total equivalents of cations. The column was then regenerated with acid, and the liberated salt solution titrated with thiocyanate. The number of equivalents of AgNO_3 thus formed permitted exact calculation of its equivalent fraction in the melt. The three samples tested showed the mixture to be homogeneous, the equivalent fraction of AgNO_3 being 0.45.

After filling the cell with the mixture and warming in the furnace, the temperature dependence of the conductivity was measured. The data are plotted in Figure 9, where they may be compared with those of Byrne, Fleming and Wetmore (30) for a mixture of almost the same composition.* The experimental activation energies so obtained are seen to show good agreement.

* Experimental activation energies show little dependence on concentration in this region.

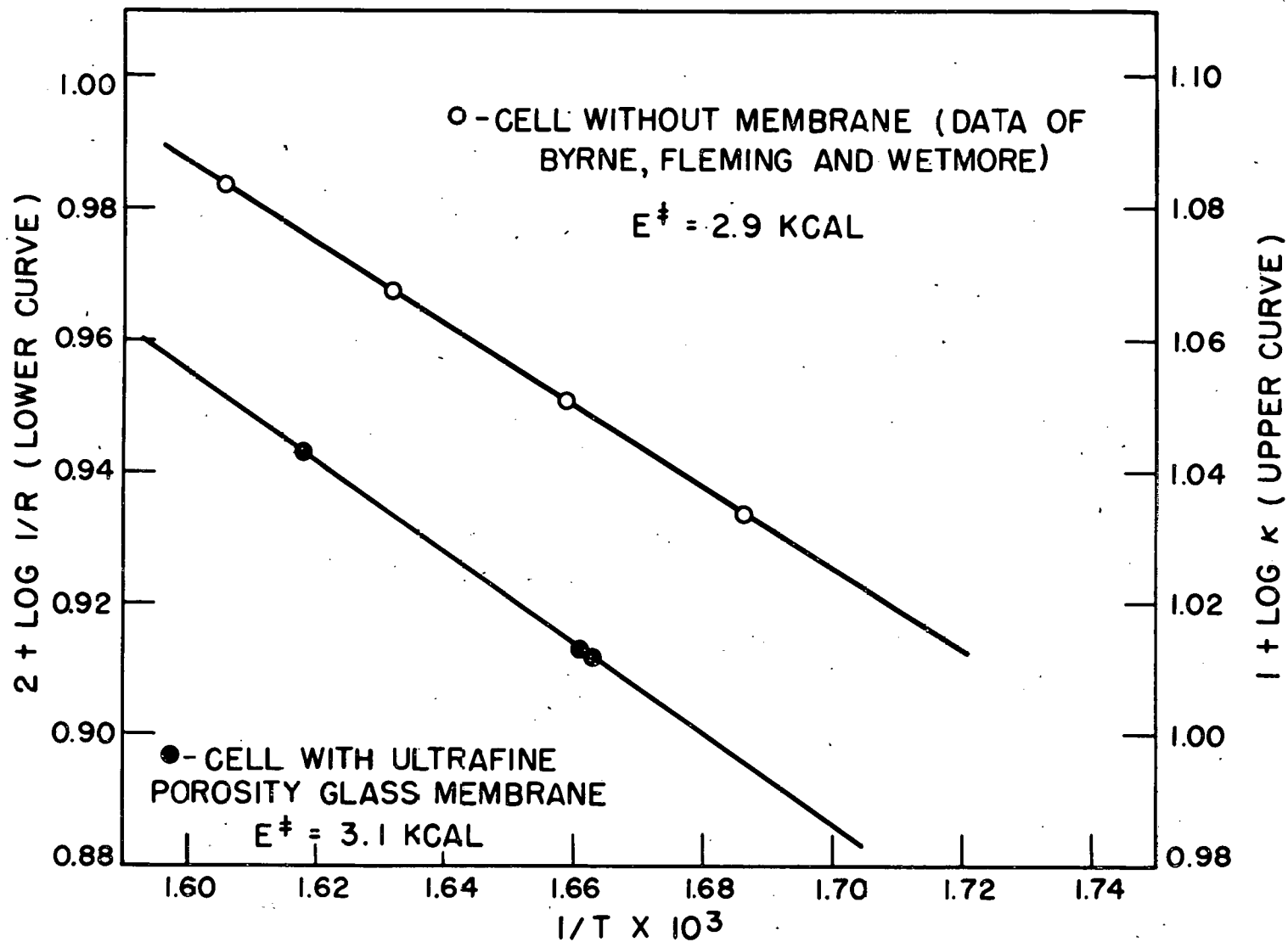

Fig. 9 - Dependence of experimental activation energy of conductivity of equimolar $\text{AgNO}_3\text{-NaNO}_3$ mixture on nature of cell.

In carrying out the electrolysis the DC current used was, unfortunately, too high, so that trees were found to have grown through the membrane. The DC used in this case was about 50 ma. Later tests showed that 25 ma would have been satisfactory.

The growth of trees through the membrane brings the two electrodes together into the same compartment. It is clear that no further concentration changes take place after this happens, since the net result of electrolysis, until the electrodes become short-circuited together, is merely the transfer of silver from one point to another within the same compartment. It can therefore be stated the actual number of coulombs which caused the measured changes to occur was some fraction of the measured number. The quantity of trees remaining in the cathode compartment after breaking the cell indicated that this fraction was probably at least $1/2$. Some limits on z , the number of faradays passed, have thus been established.

Analysis of the data obtained shows some interesting results. The upper limit on z establishes an upper limit on the transport number of the silver ion of 0.67, while a lower limit for t_{Ag} is similarly established to be 0.34. The values of t_{Na} corresponding to the same limits on z are 0.37 and 0.75, respectively. In each of these cases, as for all intermediate values of z selected, the sum of the cation transport numbers is a little greater than unity. Taking the possible experimental error into consideration, the following conclusions about this system thus appear to be justified: (a) the transport number of the nitrate ion is zero, or slightly negative; (b) the transport number of the silver ion is less than the value of at least 0.82 found by Wetmore (7) for a mixture in which the equivalent fraction of $AgNO_3$ is 0.24, i.e., t_{Ag} decreases with increasing concentration of silver ion in this region. The run should, of course, be repeated, not only in order to determine the exact values of the transport numbers, but also to ascertain the degree of precision that can be expected.

VII. DISCUSSION

The attempts of some previous workers to measure transport numbers that were reviewed earlier can be evaluated more fully in the light of data given in the present work. Thus, it has already been shown that the work of Lorenz (3)

and of Karpachev and Pal'guev (6) can probably be considered valid within the accuracy of the measurements. In both these cases the compartments were separated by membranes of relatively low porosity, such as those that have been shown here to give the most consistent results. It was also shown here, however, that membranes of slightly greater porosity may permit appreciable backflow. This observation makes the methods of Tverdovskii (4) and Shcherbakov (5) appear rather questionable. The constrictions by which their compartments were separated must have been large compared with a fine porosity fritted glass disk, so that backflow would be a considerable factor for liquids with viscosities comparable to that of PbCl_2 such as they studied. The probability of such error appears especially likely when it is recalled that these workers offered the accumulating liquid no alternative path by which to equalize hydrostatic pressure differences, as was done in the present work.

It has already been shown that a knowledge of the exact chemical formulas of the ionic species that carry the current in the melt is required before the transport data can be subjected to microscopic interpretation. No suitable methods have yet been established for determining the degree of complexing of the ions in a molten salt. For a medium in which all the ions are so close together it is even difficult to say just what is meant by the term "complex ion." The concept as used here, of course, refers to those aggregates of ions that move as a unit in transporting current through the salt.

An experiment which might be used to test for the presence of such complexes is the following. A cell of the type shown in Figure 4 (p. 60) is filled with a pure salt, some labeled cation being put into the cathode compartment only. After electrolysis the anode compartment is analyzed for the labeled ion. Correction for possible diffusion and convection is found by comparing the result with that for a similar run in which only AC current was passed. The experiment would thus show the extent to which complex anions may be involved in the migration process. A similar experiment starting with labeled anions in the anode compartment could indicate the presence of complex cations.

Very crude experiments purporting to be of the type just described were reported by Wirths (32) in 1937. Using a three-chambered cell in which the compartments were separated by fritted glass partitions, he attempted to measure the relative rates at which radioactive lead ions from the center

compartment appeared in the cathode and anode compartments during electrolysis of PbCl_2 and of PbCl_2 -KCl mixtures. The results on the pure salt showed inexcusably large deviations in the quantity of activity found in the catholyte, but demonstrated that the activity thus transported to the anolyte was in every case smaller than that found for the average blank run, a number of which were carried out to determine the extent of diffusion and convection. The magnitude of the former deviations is too great to be explained by diffusion and convection errors. Apparently it must be attributed to the author's method of analysis for radioactivity, which is not sufficiently described to permit evaluation. The absence of any complex lead-containing anions in pure PbCl_2 nevertheless appears to be established by Wirths' results.

The data presented by this worker for PbCl_2 -KCl mixtures show still poorer reproducibility. Other than the observation that the results are not inconsistent with the assumption that lead-containing anions carry some of the current, no further conclusions can be drawn from this work. It was pointed out earlier that Lorenz' experiments on the same system (3) give evidence that some of the lead ions are so complexed. This is best shown by the plot of t_{pb} vs. concentration based on his data shown in Figure 2 (p. 50). It will be noted that for equivalent fractions of PbCl_2 less than 0.67 the calculated transport numbers for the lead ion are negative, the composition of the melt at that point corresponding to the compound $\text{KCl} \cdot \text{PbCl}_2$.* Further evidence of complex ion formation in this system is shown by the work of Bloom and Heymann (16, p. 410) who noted that the equivalent conductivity of pure PbCl_2 is reduced by the addition of KCl, the equivalent conductance vs. composition curve passing through a minimum at equivalent fraction $\text{PbCl}_2 = 0.6$. It is clear that studies such as those just described help give an insight into the nature of ionic aggregation in mixtures of fused salts.

Assuming the lack of complex ions in pure PbCl_2 indicated by the experiments of Wirths (32) to be a fact, the likelihood that such ions play an important part in carrying the current in pure PbBr_2 and in TlCl appears small in view of the chemical similarities, particularly the conductivities, of these salts. Some idea of the factors affecting ionic mobility in molten salts can thus be gained from a consideration of the measured transport numbers.

*The theoretical significance of the linear relation shown, if any, is not readily apparent.

It is immediately noted in comparing the figures (Table 3, p. 64) for PbCl_2 and PbBr_2 , salts which differ principally in the size and mass of the anion, that an increase in size and mass of an ion apparently reduces its ability to carry current. That the mass of an ion is an important factor in its ability to migrate has already been shown by Klemm (33), who has used electrolysis of molten salts as a method for separating isotopes.* Considering the transport numbers found for TlCl , in which both ions are singly charged, it thus appears that the larger mass of the thallium ion is compensated by its smaller size, so that both these factors are important. This view is consistent with that presented earlier of Bloom and Heymann (16), who suggested that the smaller cations in the alkali halides carry nearly all the current. It should be noted that the salts they chose for comparison all had cations much lighter than Tl^+ .

The principal difference between PbCl_2 and TlCl is in the size and charge of the cation, the mass of each being about the same. Here the figures indicate that the smaller size of the lead ion apparently fails to compensate for a retarding effect due to its double charge. Thus, what might have been thought to be an advantage for the lead ion is really a handicap, the stronger forces of electrostatic attraction apparently making it more difficult for the ion to leave its immediate environment. A similar behavior has long been known to exist for ionic migration in solid electrolytes. Transport numbers around unity are usually found for the cations of uni-univalent salts, while the anion generally carries most of the current in di-univalent salts (34).

The observations just considered for the three molten halides also appear consistent with the results found for pure AgNO_3 . In this salt the cation is heavier than the anion, but much smaller, the charges being the same. It is therefore not surprising to find the silver ion carrying three-fourths of the current. In the case of the $\text{AgNO}_3\text{-NaNO}_3$ mixtures, however, it is apparent that other factors must be taken into consideration. Here the results show the silver ion carrying most of the current when present to a smaller extent, but apparently giving way to sodium ion conductance as the concentration of silver ion is increased. It should be pointed out that this conclusion is not based

*The experiments are set up in such a way that the separation depends on the rate of ionic migration, not on the rate of the electrode process.

solely on the result of the single experiment described, but on additional data of Duke and Ida (35) using experiments similar to the type employed by Wetmore (7). The work indicated that at still higher concentrations of silver ion the sodium carries an even larger fraction of the current, so that it is apparently the cation present to the smaller extent that is the more mobile in such mixtures.

Much more data must be gathered before it will be possible to form a comprehensive picture of the microscopic nature of the conductivity process in fused salts. An important step in the development of such an understanding would be to find a relation between ionic transport by diffusion through the salt and ionic migration under an applied potential. It was shown earlier that the use of the Nernst-Einstein equation is probably not valid for molten electrolytes. This equation relates the conductivity of an ion to its self-diffusion coefficient, D_1 , by the expression

$$\lambda_i = \frac{D_1 F^2 z_i}{RT},$$

where F is the faraday and z_i the charge on the ion. It was pointed out that the derivation of the equation involves the assumption that the two processes have the same mechanism. Reflection on the end result of these two processes brings to light their fundamental difference. Considering the "self-diffusion" of labeled thallium ions into $TlCl$, for example, it is clear that the net result observed is the interchange of cations, i.e., the labeled thallium ions take the place of normal thallium ions in the liquid and vice versa. In electrical conductance, on the other hand, the exchange of position is between thallium ions and chloride ions. It is clear that in order for the mechanisms of the two processes to be considered the same, it is necessary that the exchanges mentioned here each consist of two independent steps taking place in opposite directions. The Nernst-Einstein equation is thus valid only for those limiting cases where the motions of ions are few and far between. In the fused salt, however, it is not unlikely that the diffusion of some of the chloride ions may be coupled with the diffusion of some of the thallium ions. This would effectively amount to a transport of $TlCl$ "molecules," which would show up as movement of the thallium ion in self-diffusion experiments, but would contribute nothing to the conductivity of the thallium ion.

Thus it is not surprising that the transport number of 0.95 calculated for the thallium ion by Van Artsdalen (15) from self-diffusion data of Klemm (18) is almost twice the actual value of 0.51 found in the present work.

In considering the relation between diffusion and conductance, it is instructive to compare the activation energies of the two processes. The experimental activation energies should not be compared, however, since theoretical treatment shows that the experimental activation energy of diffusion differs from the heat of activation by the quantity RT (2, p. 197), while the experimental activation energy in the latter case is the same as the heat of activation. Thus, even in the limiting case the Nernst-Einstein equation shows that the temperature dependence of the conductivity of an ion should correspond to the temperature dependence of the quantity (D_1/T) . Since the transport number of the thallium ion has been shown in the present work to be independent of temperature within the experimental error, the conductivity of the whole salt should show very nearly the same temperature dependence as the conductivity of the cation, i.e., the chloride ion must have the same activation energy of conductance as the thallium ion if the fraction of the current carried by each is to remain unchanged with changing temperature. A comparison of the heat of activation of self-diffusion of the thallium ion in $TlCl$ with the heat of activation of conductivity of the salt is shown in Figure 10, the data for the former curve being taken from the work of A. Klemm (18) and that for the latter from conductivity measurements of Tubandt and Lorenz (36) combined with density data of W. Klemm (37). It should be noted that since the density of a salt is a function of temperature, it is important to use equivalent rather than specific conductance in such comparisons. The agreement between the slopes of the two curves shown in Figure 10 suggests that there may well be some correlation between the two processes which would make a more inclusive theoretical approach to the problem worthy of further investigation.

As just noted for the case of $TlCl$, the lack of dependence on temperature of the measured transport numbers indicates that if the conductivity of a molten electrolyte can be expressed as a sum of exponential terms (equation (6), p. 52), the activation energies of each of the ions must be very nearly equal. Of the salts listed in Table 3 (p. 64) only in $PbBr_2$ do the transport numbers show any significant dependence on temperature. Even for this case the dependence

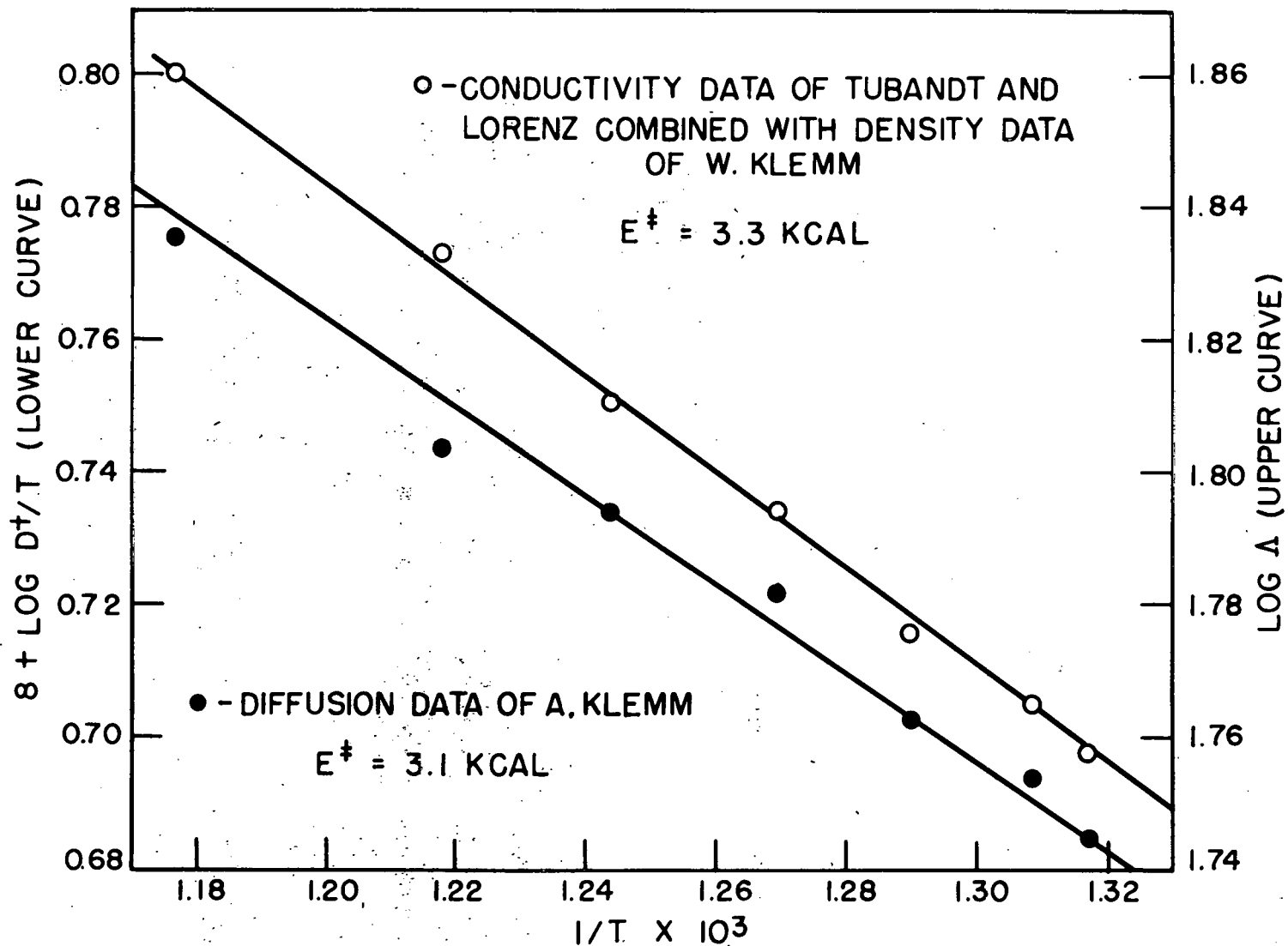

Fig. 10 - Heat of activation of self-diffusion of thallium ion in TlCl compared with heat of activation of conductivity of TlCl.

is small enough that it might possibly be explained by experimental error. If it should be found for fused salts generally that the transport numbers show no dependence on temperature, then the conclusion might be justified that the rate determining step of the migration process involves the simultaneous motion of both cations and anions, so that the exchange referred to above could not be further subdivided into individual jumps. The transport number data presented here, however, are not sufficiently accurate to justify the conclusion that the individual ionic activation energies are the same for a given salt. Over the limited variations of temperature for which they were measured, a change in the transport numbers which lay within the experimental error of these figures could correspond to a difference in activation energies for the two ions of as much as 0.5 kcal. In the one case where a significant change was actually noted, that of PbBr_2 , the indicated difference between the activation energies calculated for the two ions is about 1.2 kcal, the experimental error of this figure clearly being quite large.

The type of significance which might be attached to such measurements of the temperature dependence of the transport numbers will now be illustrated briefly by considering the data in the present work to be sufficiently accurate to warrant such interpretation. Considering first the figures for PbCl_2 , it will be noted that no temperature dependence of the transport numbers was observed. This suggests that the E_1 of equation (6) are the same for both ions. Looking at the values of the transport numbers themselves, however, it is clear that the chloride ion carries the larger fraction of the current. Thus it must be that A_{Cl} of equation (6) is considerably larger than A_{Pb} . According to the theory of reaction rates (2) this indicates that the entropy of activation is more favorable for the singly charged ion. The results on PbBr_2 would seem to be consistent with this interpretation. For in this case the data indicate that the bromide ion carries the larger fraction of the current in spite of having the larger activation energy of migration. Thus, it again appears that the doubly charged ion undergoes the larger entropy decrease in attaining the activated state. In TlCl , where both ions have the same charge, the activation energies again appear to be the same for each ion. This time, however, both ions carry equal fractions of the current, indicating once more that it is the relative charges of the ions that most strongly influence the relative values of A_1 . The experimental error in the AgNO_3 measurements was too great to bring this salt into the present discussion. On the basis of the picture

presented here, however, one might expect to find a larger activation energy for nitrate than for the silver ion.

One view of the microscopic nature of the liquid state suggests that some regions are to be found in which there exists a high degree of order, as in a solid crystal, while other regions have a considerably more random structure (38). If such a picture has some degree of validity, the question arises as to which type of regions are more favorable for ionic migration. The very low conductivity and high activation energy of conductance observed in solid salts suggest that highly ordered regions are not too conducive to the movement of ions. The relatively high conductance and low activation energy in liquid salts may thus be due to the relative ease with which the ions can move in disordered regions of the liquid, migration in the more ordered regions contributing little to the conductivity of the melt.

Such a picture might be used to help explain the interesting results obtained in the measurement of transport numbers in the AgNO_3 - NaNO_3 mixtures. It was pointed out that as AgNO_3 is added to NaNO_3 the transport number of the silver ion increases rapidly until at an equivalent fraction of 0.24 the silver ion is carrying more than 80% of the current. As more of the silver salt is added, t_{Ag} then begins to drop off, the sodium ion carrying a larger and larger fraction of the current. A corresponding behavior for the other cation seems to hold when NaNO_3 is added to AgNO_3 , the transport numbers of the two cations probably being nearly equal for an equimolar mixture as was indicated by the experiment carried out in this work. It should be pointed out that the equivalent conductivities of the two salts are not far apart, that of AgNO_3 being slightly larger, and that the variation of equivalent conductance with concentration is very nearly linear in going from one pure salt to the other (30). The experimental energies of activation, on the other hand, seem to show irregular variations over the concentration range (30), which might be expected in view of the behavior of the transport numbers. The structure of the liquid suggested above might help account for these observations in the following way.

In a pure salt, NaNO_3 , for example, the fraction of the liquid that might be considered disordered is principally a function of temperature, and contains the same ionic species as are present in the ordered regions. When a small amount of AgNO_3 is added, the latter salt may be considered as an impurity in the former. The silver ions are too far apart to collect into any sort of ordered lattice with

respect to each other, and do not fit neatly into NaNO_3 lattices. The silver ions thus become centers of disorder in the melt, the net result being that the disordered fraction of the liquid is concentrated in the neighborhood of the silver ions. Since, as was indicated above, these are probably the regions in which electrical conductivity takes place, the silver ion has a much higher mobility when present to a minor extent. The same argument may be used, of course, to explain the behavior of AgNO_3 containing a small fraction of NaNO_3 . The intermediate concentrations probably have appreciable fractions of each cation in disordered regions.

It should be emphasized that the above discussion is entirely within the realm of speculation, and is not to be considered a comprehensive explanation of the observed transport numbers. It serves to indicate, however, the way in which the study of transport numbers in fused salts may contribute to the development of a general theory on the nature of the liquid state. A great deal of information from many different sources must be taken into consideration in the constructing of such a theory, and it is hoped that the present work may stimulate further investigation in a relatively unexplored and challenging field.

VIII. SUMMARY

1. The meaning of transport numbers in fused salts has been discussed in the light of the inapplicability of the usual definition applied to electrolytic solutions. A microscopic definition has been proposed which permits division of the conductance of molten electrolytes into a sum of meaningful ionic conductances which depend on the ability of each ion to move through the bulk of the liquid.

2. Attempts of previous workers to measure transport numbers in fused salts have been reviewed with respect to their validity and significance. It has been shown that, while a few of the papers present significant data, the failure of any previous investigators adequately to consider the nature of the quantities they were measuring has led in other cases to the publication of completely useless or uninterpretable experimental results.

3. A cell has been developed for measuring the transport numbers of the ions in pure molten salts. It has two vertical electrode compartments separated by a porous glass

membrane. The displacement during electrolysis of an air bubble in a capillary tube connecting the two compartments yields data which can be combined with known density data to calculate the transport numbers, assuming the simplest formulas for the current-carrying ions. The validity of the use of this cell for transport number measurements in fused PbCl_2 has been verified by a number of different experiments and theoretical considerations. A criterion for indicating its applicability in other cases has also been proposed.

4. A cell for measuring transport numbers in mixtures of fused salts has been described. The electrode compartments are again separated by a porous glass membrane. Results with this cell are found by determining the actual quantity of each ion transferred from one compartment to the other on electrolysis.

5. Application of the former cell to a number of pure fused salts has yielded the following experimental transport numbers for the negative ions: PbCl_2 - 0.76 at 565 and at 635°C.; PbBr_2 - 0.65 at 500 and 0.67 at 600°C.; TlCl - 0.49+ at 475, at 505 and at 525°C.; AgNO_3 - about 0.24 at 225 and at 275°C. In an equimolar AgNO_3 - NaNO_3 mixture use of the latter cell has indicated that the nitrate ion carries a negligible fraction of the current, while the maximum transport number of the silver ion is less than 0.67.

6. An experiment has been proposed which would permit evaluation of the extent to which complex ions carry current in molten salts. It has been shown how such information, combined with that of the type assembled in the present work, may be of considerable use in the development of a theory of the liquid state.

IX. LITERATURE CITED

1. H. S. Harned and B. B. Owen, "The Physical Chemistry of Electrolytic Solutions," 2nd ed., Reinhold Publishing Corporation, New York, 1950.
2. S. Glasstone, K. J. Laidler and H. Eyring, "The Theory of Rate Processes," McGraw-Hill Book Company, Inc., New York, 1941.
3. R. Lorenz and W. Ruckstuhl, Z. anorg. Chem. 52, 41-7 (1907).

4. I. P. Tverdovskii, "The Measurement of Transference Numbers in Magnesium Chloride and Potassium Chloride" (in Russian), Bibl. VAMI (1934). (Original not available for examination; cited by Baimakov and Samusenko (12, p. 15)).
5. I. G. Shcherbakov, "The Measurement of Transference Numbers in the Electrolysis of Carnallite" (in Russian), Bibl. VAMI (1934). (Original not available for examination; cited by Baimakov and Samusenko (12, p. 16)).
6. S. Karpachev and S. Pal'guev, Zhur. Fiz. Khim. 23, 942-52 (1949). (Translated from the Russian by L.A. King, Ames Laboratory, Ames, Iowa, 1953).
7. P. M. Azziz and F. E. W. Wetmore, Can. J. Chem. 30, 779-82 (1952).
8. J. R. Partington and H. S. Taylor, "A Treatise on Physical Chemistry," Vol. I, pp. 678-83, D. Van Nostrand Co., New York, 1931.
9. S. Hill and F. E. W. Wetmore, Can. J. Chem. 32, 864-6 (1954).
10. W. Isbekow, Z. anorg. u. allgem. Chem. 158, 87-93 (1926).
11. P. F. Antipin, "Studies of the Transference Numbers of Ions in Fused Salts" (in Russian), State Institute of Applied Chemistry, 1935. (Original not available for examination; cited by Baimakov and Samusenko (12, p. 24)).
12. Y. V. Baimakov and S. P. Samusenko, Trans. Leningrad Ind. Inst. 1938 No. 1, 3-26. (In Russian; available as U. S. Atomic Energy Commission Translation No. 1670).
13. K. G. Schwarz, Z. Electrochem. 45, 740-3 (1939).
14. G. Kortum and J. O'M. Bockris, "Textbook of Electrochemistry, Elsevier Publishing Company, New York, 1951.
15. E. R. Van Artsdalen, I. S. Yaffe and F. J. Miller, Paper No. 140 presented at 107th meeting of the Electrochemical Society, Cincinnati, May 4, 1955. (Unpublished).

16. H. Bloom and E. Heymann, Proc. Roy. Soc. (London) A188, 392-414 (1947).
17. W. Shockley, "Electrons and Holes in Semiconductors," pp. 299-302, D. Van Nostrand Company, Inc., New York, 1950.
18. E. Berne and A. Klemm, Z. Naturforsch. 8a, 400-3 (1953).
19. J. H. Wang and S. Miller, J. Am. Chem. Soc. 74, 1611-5 (1952).
20. R. Lorenz, H. Frei and A. Jabs, Z. physik Chem. 61, 468 (1907).
21. P. Pascal and A. Jouniaux, Compt. rend. 158, 414 (1914).
22. Laboratory Glassware Catalog No. LP34, Corning Glass Works, Corning, New York, 1954.
23. J. D. Corbett and S. von Winbush, J. Am. Chem. Soc. 77 (in press).
24. F. R. Duke and R. Laity, J. Am. Chem. Soc. 76, 4046 (1954).
25. F. R. Duke and R. W. Laity, J. Phys. Chem. 59 (in press).
26. J. L. Hyde, J. Am. Chem. Soc. 73, 1861-2 (1951).
27. "International Critical Tables," McGraw-Hill Book Company, Inc., New York, 1926.
28. P. Drossbach, "Electrochemie geschmolzener Salze," Julius Springer, Berlin, 1938.
29. B. E. Conway, "Electrochemical Data," Elsevier Publishing Company, New York, 1952.
30. J. Byrne, H. Fleming and F. E. Wetmore, Can. J. Chem. 30, 922-3 (1952).
31. N. A. Lange, "Handbook of Chemistry," 7th ed., Handbook Publishers, Inc., Sandusky, Ohio, 1949.
32. G. Wirths, Z. Electrochem. 43, 486-9 (1937).
33. A. Klemm, Z. Naturforsch. 6a, 487-8 (1951).

34. P. W. M. Jacobs and F. C. Tompkins, Quart. Rev. 6, 238-61 (1952).
35. F. R. Duke and N. Ida, Ames Laboratory, Ames, Iowa (Unpublished research), 1955.
36. C. Tubandt and E. Lorenz, Z. physik. Chem. 87, 527 (1914).
37. W. Klemm, Z. anorg. u. allgem. Chem. 152, 243 (1926).
38. W. J. Moore, "Physical Chemistry," p. 407, Prentice-Hall, Inc., New York, 1950.