

**Materials Design Considerations and Selection for a Large  
Rad Waste Incinerator (U)**

CONF-970332--6

by

P. R. Vormelker

Westinghouse Savannah River Company

Savannah River Site

Aiken, South Carolina 29808

C. F. Jenkins

H. Holmes-Burns

**MASTER**

**DISTRIBUTION OF THIS DOCUMENT IS UNLIMITED** *df*

A document prepared for CORROSION 1997 at New Orleans, LA, USA from 3/9/97 - 3/14/97.

DOE Contract No. DE-AC09-89SR18035

This paper was prepared in connection with work done under the above contract number with the U. S. Department of Energy. By acceptance of this paper, the publisher and/or recipient acknowledges the U. S. Government's right to retain a nonexclusive, royalty-free license in and to any copyright covering this paper, along with the right to reproduce and to authorize others to reproduce all or part of the copyrighted paper.

**DISCLAIMER**

**Portions of this document may be illegible in electronic image products. Images are produced from the best available original document.**

## DISCLAIMER

This report was prepared as an account of work sponsored by an agency of the United States Government. Neither the United States Government nor any agency thereof, nor any of their employees, makes any warranty, express or implied, or assumes any legal liability or responsibility for the accuracy, completeness, or usefulness of any information, apparatus, product, or process disclosed, or represents that its use would not infringe privately owned rights. Reference herein to any specific commercial product, process, or service by trade name, trademark, manufacturer, or otherwise does not necessarily constitute or imply its endorsement, recommendation, or favoring by the United States Government or any agency thereof. The views and opinions of authors expressed herein do not necessarily state or reflect those of the United States Government or any agency thereof.

This report has been reproduced directly from the best available copy.

Available to DOE and DOE contractors from the Office of Scientific and Technical Information, P.O. Box 62, Oak Ridge, TN 37831; prices available from (615) 576-8401.

Available to the public from the National Technical Information Service, U.S. Department of Commerce, 5285 Port Royal Road, Springfield, VA 22161.

**Materials Design Considerations and Selection for a Large Rad Waste Incinerator**

by

P. R. Vormelker, C. F. Jenkins, and H. Holmes Burns  
Westinghouse Savannah River Company  
Aiken, South Carolina 29802

A paper proposed for presentation at the  
NACE Corrosion '97 Conference  
New Orleans, LA  
March 9-14, 1997

and for publication.

---

The information contained in this article was developed during the course of work under contract No. DE-AC09-89SR18035 with the Department of Energy. By acceptance of this paper, the publisher and/or recipient acknowledges the U.S. Government's right to retain a non-exclusive, royalty-free license in and to any copyright covering this paper along with the right to reproduce, and to authorize all or part of this document.

## MATERIALS DESIGN CONSIDERATIONS AND SELECTION FOR A LARGE RAD WASTE INCINERATOR

P. R. Vormelker, C. F. Jenkins, and H. Holmes Burns  
Westinghouse Savannah River Company  
Aiken, South Carolina 29808

### ABSTRACT

A new incinerator has been built to process self-generated, low level radioactive wastes at the Department of Energy's Savannah River Site. Wastes include protective clothing and other solid materials used during the handling of radioactive materials, and liquid chemical wastes resulting from chemical and waste management operations. The basic design and materials of construction selected to solve the anticipated corrosion problems from hot acidic gases are reviewed. Problems surfacing during trial runs prior to radioactive operations are discussed.

Keywords: incinerator, corrosion, erosion, high temperature, chloride, nickel alloys, saturated gases, radioactive wastes, hazardous wastes

### INTRODUCTION

The Consolidated Incinerator Facility (CIF) at the Department of Energy's Savannah River Site is a Resource Conservation and Recovery Act (RCRA) permitted hazardous, mixed, and low-level radioactive waste incinerator. As required by the RCRA permit, the unit is currently undergoing testing to demonstrate acceptable performance prior to full scale start up. The CIF includes a rotary kiln with an afterburner, an exhaust gas cleanup system consisting of a quench tower, steam-hydro scrubber, cyclone separator, demister, reheater, HEPA (high efficiency particulate air) filters, and storage tanks to hold liquid radioactive wastes prior to incineration. The CIF is designed to: 1) reduce the total volume of low-level radioactive waste; 2) reduce shipments of burnable hazardous waste for off-site treatment and disposal; and 3) treat hazardous and mixed wastes prior to land disposal. The radioactive wastes scheduled for destruction are generated during normal Savannah River Site operations and include fuel oils, paints, hazardous chemicals, low level radionuclide contaminated materials (e.g., worker clothing and cleanup materials), organic and aqueous process liquids, laboratory wastes, and decontamination materials. These wastes contain many corrosive impurities such as Cl, S, P, F, Zn, Pb, and Na that under combustion will produce corrosive, gaseous components such as HCl, SO<sub>2</sub>, and HF, etc. The acidic gases are cooled in the off gas system and neutralized with NaOH. Most of the corrodents are retained with the coolant, the principal carry over in the gas stream being chloride salts. As a result, some chloride induced corrosion is anticipated in the CIF off gas system.

## DESIGN

The incinerator is designed to operate at 1100°C (2012°F) with a heat generation capacity of  $21.1 \times 10^9$  Joules/hour ( $20 \times 10^6$  BTU/hr) and a flue gas design rate of 935 m<sup>3</sup>/minute (33,000 cfm). A conceptual drawing illustrating the layout of the facility is shown in Figure 1. Average chloride discharge to the offgas from the incoming boxed solid wastes is expected to reach a maximum of 210 kg/hr (460 lb/hr), with normal operating levels of 16 kg/hr (35 lb/hr). Preliminary design parameters and materials selection were presented in 1989 and 1991.<sup>(1,2)</sup>

The off gases from the fuel-fired rotary kiln are quenched by a wet spray, with subsequent flow through a steam-jet scrubber, a cyclone separator and mist eliminator for liquid-gas separation, and a reheater prior to the downstream dry high efficiency particulate air (HEPA) filters. The CIF flowsheet is shown in Figure 2. The spray-quench cooler is used to saturate and cool the flue gas stream. Next, a scrubber is used for initial particle capture and acid gas removal. Initial particle removal is required to take out the bulk of the particulate matter so that downstream devices are not fouled, poisoned, or overburdened with particulate matter. Entrained water droplets are then removed by the cyclone separator and mist eliminator. The flue gas is then heated to a temperature above the dewpoint and passed through HEPA filters which are able to capture very fine particles.

The predominant operational parameter that facilitates corrosion in the CIF is the high saturation temperature, 88°C (191°F), maintained throughout the off-gas system. Even though the off-gas section is equipped with a reheater to maintain conditions sufficiently above the saturation temperature, downstream condensation of moisture still occurs due to localized air in-leakage. The condensed moisture droplets provide nuclei for air-borne chloride salt particulate condensation, thereby increasing the corrosion potential.

It is critical that the gas temperature remain above the dewpoint and that all the water droplets completely evaporate. Otherwise, corrosion in the piping and filter vaults may be expected, and plugging will occur in the HEPA filters from condensed moisture and other gases.

## COMPONENT MATERIALS SELECTION

### Rotary Kiln

The kiln, lined with firebrick, is fueled by an oil burner and a ram operated box feed system for supplying solid wastes. These wastes include items such as PVC plastic suits, gloves, and used cleaning materials, typical of a nuclear installation. An aqueous liquid waste injection nozzle is positioned near the fuel oil injector for incineration of liquid wastes that will make up less than 10% of the feed. The kiln assembly and connecting ducts are constructed of carbon steel faced with 23 cm (9 in.) of 90% alumina refractory firebrick plus 2.5 cm (1 in.) of high temperature insulating blanket. Combustion ash is directed to an underwater collection tank by an alloy 600 (UNS N06600) discharge chute. The flue gas exit temperature near the discharge chute is approximately 980°C (1800°F). The function of this chute is to guide the ash into a water pool which acts to prevent the hot discharge gases from escaping. The water seal also maintains a small pressure differential between the kiln and the outer housing. Alloy 600 was chosen because of its strength and fatigue properties at high temperatures, and its good oxidation resistance.

## Secondary Combustion Chamber (SCC)

The hot gases from the rotary kiln are further consumed in the SCC. The SCC is firebrick lined carbon steel with an insulating blanket similar to the rotary kiln. Radioactive waste oil is fed to the SCC through a nozzle to assist in complete combustion of the hot gases.

## Off Gas Duct

The temperature of the exhaust gas stream from the SCC is approximately 1093°C (2000°F). The discharge is to an off gas duct having the same make up as the kiln and the SCC.

## Expansion Joint

Expansion joints are located at both ends of the off-gas duct, i.e. at the SCC discharge and at the entry to the quench vessel. These will see the high temperature flue gases and allow for thermal expansion of the duct versus the fixed SCC and quench vessels. The outer skin is 304L stainless steel, with a telescoping inner liner of alloy 600. The inner wall is lined with 23 cm (9 in.) of firebrick, so that no metal is directly exposed to the gases.

## Quench Inlet Nozzle

The quench contains four separate rings of spray nozzles that reduce the off gas temperature to approximately 120°C (250°F) and the quench liquid to 82°C (180°F). The quench inlet structure and nozzles are fabricated from alloy C-276 (UNS N10276) or alloy C-22 (UNS N06022), selected primarily for chloride resistance.

The spray portion of the vessel is constructed of carbon steel. This is coated with a copolymer of ethylene/chlorotrifluoroethylene and lined with carbon brick insulation. Though the quench solution is controlled at low pH to avoid sodium bicarbonate formation from carbon dioxide, high pH excursions are expected. Carbon brick was chosen in lieu of acid brick for this reason. An alloy C-276 connection joins the quench vessel to the quench separation tank, which is located at a lower elevation.

## Quench Separation Tank and Off Gas Transition Ductwork

The tank (at the bottom of the quench vessel) and the ductwork which connects the quench vessel and the scrubber are constructed of steel with a PVDF liner, for exposure to saturated gases below 93°C (200°F). The steel structure is used in lieu of FRP to insure containment of radioactive gases in the event of a high temperature excursion resulting from a quench system failure. FRP has a high temperature limitation of approximately 232°C (450°F).

## Scrubber Housing and Mixing Tube

Gases in the transition duct are at approximately 82°C (180°F) prior to injection of high pressure steam (225 psig). At the injection point, the scrubber and the mixing tube are constructed of alloy C-276 in order to provide resistance to the wet chlorides at this location (2 to 10% NaCl at pH 7-9).

### Cyclone Separator

After expansion, the scrubber fluid is at 87°C (189°F) and metal ducting is no longer required. A 10.7 m (35 ft) length of structural fiberglass reinforced laminate (FRP) duct is used. An internal vinyl ester liner has been applied for corrosion resistance. There is a wear plate (alloy C-276) at the cyclone inlet to provide wear resistance to the high velocity gases and liquid. The gas is discharged through the duct to a mist eliminator (C-276). Another 1.2 m (4 ft) of FRP duct joins the mist eliminator to a reheater, which is fabricated from alloy Al6XN (UNS N08367).

### Remainder of System

The rest of the duct system downstream from the reheater is constructed of carbon steel with a vinyl ester liner. Approximately 107 m (350 ft) of 0.8 m (30 in.) and 0.9 m (36 in.) duct are located between the reheater and stack. Stainless steel HEPA housings, containing the high efficiency particulate air filtration media, are centered along the length of the ducting. A 0.9 m (36 in.) steel collector duct discharges the gases to the FRP stack. Gases exit at 65°C (150°F).

### Liquid Storage Tanks

Four holding tanks are used for storage and blending of incoming waste liquids prior to injecting them into the incinerator. The tanks are constructed of carbon steel (ASME SA-516 Gr. 70) with capacities of 16-47 m<sup>3</sup> (4,300 to 12,500 gallons). They will contain radioactive organic and aqueous wastes, and #2 fuel oil for burning. The corrosion control strategy for these tanks includes corrosion coupons, electrical resistance probes, and periodic ultrasonic thickness inspections. Exposure time to corrosive wastes will be limited and monitored.

## OPERATING EXPERIENCE DURING TRIAL RUNS

The RCRA permit requires the facility to demonstrate acceptable performance under design conditions such that stack emissions are within the permitted guidelines. During a trial burn to evaluate CIF performance for the maximum solid waste feed chemistry conditions, several problems arose. These included an aqueous waste feed system failure, filter failures and HEPA filter housing corrosion, erosion in a feed injection nozzle, and wet steam erosion. These situations will be described individually.

### Aqueous waste system

The aqueous waste feed system (AQW) is designed to deliver a liquid waste stream to the rotary kiln for incineration. This system is constructed of 1.3 to 2.5 cm (0.5 to 1.0 in.) schedule 80 carbon steel pipe. The trial burn liquid feed consists of a mixture of a base simulated waste modified with either or both of two metal spiking solutions (Tables 1, 2 and 3). The mixtures were introduced into the rotary kiln through the AQW injection gun.

The injector gun at the kiln is constructed of a cast steel manifold, two concentric steel pipes, and a Type 303 stainless steel nozzle, Figure 3. The center pipe contains

the waste stream, and the outer pipe and annular space contains low pressure (120 psig) steam for nozzle cooling and for waste stream atomization. Spray atomization occurs as the streams are mixed at the tip of the injection gun during discharge.

Two kinds of failure were experienced at the injector during early trial runs. These were due to corrosion and steam erosion. Steam erosion occurred within the manifold as a consequence of wet steam and a 90° change in direction, Figure 4. In the figure, impingement was at position B on the OD of the inner pipe and a leak did occur. At the time of this failure, waste liquid pump pressure exceeded the steam pressure and acids were forced into the annular space, i.e. into the steam system. This led to corrosion in the condensate piping and failure at a nearby steam trap.

During downtimes, the internal steel pipe of the injection gun became plugged due to evaporation and precipitation at the hot end. Note that the end is actually within the kiln space, which is at 800 -1000°C. Corrosion developed rapidly within the pipe and failure was the result of exposure to the hot HNO<sub>3</sub> and HCl acids. Examination showed significant wall thinning (Figure 5) and pitting. The corrosion rate is estimated to be greater than  $1.3 \times 10^4$  μm/y (500 mpy) based on linear polarization testing at ambient temperature.

Another leak, due to corrosion, occurred after the inner pipe was replaced with a stainless steel pipe. Chloride stress corrosion cracking and pitting were observed. Steam ingress into the waste side resulted in upstream failure of PVC feed pipe which had been temporarily installed as part of the spiking system.

When the simulated waste solution was being fed through the AQW, the upstream carbon steel system piping also experienced some degradation. However, the time of exposure was short and replacement of the piping was not necessary.

#### HEPA Filter Corrosion

From the time the kiln was fired up the efficiency of the HEPA filters was low. During the trial burn throughput dropped rapidly and pluggage was suspected. Previous work by Holmes and Burns indicated that this might occur.<sup>(3)</sup> The pre-filter and the HEPA filter components developed large holes. The pre-filter is a non-woven pad of fine 304 stainless steel wire, approximately 0.1 mm (0.004 in) in diameter supported by a woven fiberglass cord material. The HEPA filter is a non woven paper material. Extensive wire loss and degradation was evident in the pre-filter, whereas the HEPA filter was discolored and had a single hole centered on the face.

Pieces of the pre-filter wire were examined optically and in the scanning electron microscope. Wire lengths ranged from 0.32 to 5 cm (0.125 to 2 in.). Figure 6 shows an individual fiber with substantial pitting corrosion. Large round bottomed pits grew completely across the wire (Figure 7), or fracture occurred through the reduced cross sections. Deposits on the wire were primarily NaCl, KCl, and small quantities of iron oxide. The pitting is related to the high chloride environment.

Deposits on the HEPA included sodium and potassium chlorides, sulfides, and about 5% iron oxide. As the thick deposit piled up on the entry surface, pore pluggage occurred. Thus air flow decreased and air pressure increased, ultimately leading to breakage and penetration at the center of the paper membrane .

On the basis of the filter media failures, corrosion to the stainless steel HEPA housing was suspected. The wet, offgas condensate was determined to contain 6000 ppm chloride and 3000 ppm sulfate ions, and inspection was deemed necessary. Large cracks were found on the pre-filter access door seal frame, Figure 8. The cracks showed extensive branching, suggesting chloride stress corrosion cracking. Metallurgical evaluation was not performed. Other cracks were found in the heat affected zones of tack welds joining an interior duct wall to the floor, Figure 9. Their appearance was not typical of chloride stress corrosion cracking.

The carbon steel ductwork was uniformly corroded under the wet offgas conditions. Ultrasonic thickness measurements confirmed that corrosion had been minimal. However, the particulates plugging the HEPAs were fine iron oxides. Also, mild oxidation, in the form of a flaky rust, could be easily delaminated from the interior surface of the duct. It was obvious that this was the source of the fine particulate oxides at the filters. The corrosion rate was estimated at greater than 2.5 cm (1 in.) per year.

#### Quench Nozzle Erosion

As previously mentioned, the quench tower contains several spray nozzles for reducing gas and quench liquid temperatures from 1095°C (2000°F) to less than 120°C (250°F). Several of these alloy C-276 nozzles were plugged with a black substance after the trial, and holes appeared on the outer surface of the nozzles. Sectioning revealed that severe erosion had taken place (Figure 10). There was no indication of stress corrosion cracking. Analysis of the black product by energy dispersive x-ray spectroscopy indicated high quantities of silicon and lesser amounts of potassium, calcium, chlorine and iron (Table 4). A limited amount of fly ash is contained in the recycled cooling water. Most of the elements can be accounted for based on the feed material. The iron is the result of corrosion in the system but silicon had to be part of the solid feed (clay absorbant) to the incinerator. High silicon values were also found in the blowdown system.

#### Tank Farm Corrosion Monitoring

The problems encountered during the trial run raised concern about the storage tanks. Because the on-line corrosion probe was not working, one tank coupon was removed for inspection and no corrosion was observed. Nevertheless, laboratory coupon testing was initiated in solutions taken from the blend tanks because sump water had been added to the tanks after a rainstorm. The solutions contain 90 % fuel oil and 10 % solvents. The solvents include trichloroethane (~2100 ppm), toluene (~30,000 ppm), and xylene (~6000 ppm). Tank #1 showed two phases, one primarily oil plus these solvents, and the other, an aqueous phase containing 260 ppm toluene, 210 ppm xylene, and 2100 ppm methyl ethyl ketone. This was the tank with the added water. In Table 5, the aqueous phase (lower phase) showed the highest corrosion rates: 114  $\mu\text{m}/\text{yr}$  (4.5 mpy) after 60 days. The corrosion rate for the first 10 days was almost double the latter rate. The reduction is attributed to passivation, or the development of a protective layer of deposited corrosion compounds during the initial exposure period. The other corrosion rates are significantly lower, approximately 3.1  $\mu\text{m}/\text{yr}$  (0.124 mpy) or less. Corrosion is significantly enhanced by the presence of water.

#### SUMMARY

The early trial runs in a new mixed waste incinerator revealed some problem areas that demanded correction before radioactive operation could begin. In particular, the saturated off-gas resulted in numerous unanticipated problems. Alloy C-276 quench nozzles suffered severe erosion and rapid loss of efficiency during use. Replacement nozzles have not been chosen but cobalt alloys and ceramics are being considered. Also, the addition of filters to the recirculation cooling water system is being considered to mitigate nozzle erosion. HEPA filter failures were related to acid attack in the steel ducts, leading to the generation of fine rust particulates which, together with condensate loaded the filter media. The acid water condensate also caused rapid degradation of the wire prefilters, and cracking in the HEPA filter housings. Prefilter wire material was changed to alloy C-276, and new housings were ordered. The steel exhaust duct and the interior of the new HEPA bodies were coated with a vinyl-ester material for corrosion protection. The injection nozzle material was changed to alloy C-276 to avoid further corrosion by the test solutions, and the spiking arrangement was modified to avoid upstream damage in the liquid feed system. The CIF is proceeding with trial runs and anticipates radioactive start-up in early 1997.

#### ACKNOWLEDGEMENTS

The authors would like to thank Dr. W. L. Daugherty for the failure analysis of the AQM injection nozzle and to Dr. J. Mickalonis for corrosion measurements of the tank liquids. Thanks are also due to B. Bordon, J. E. Wilderman, P. DeMaere, T. B. Curtis, and N. R. Carpenter of the MTS Metallurgical Laboratory for their assistance in sample preparation and photography.

#### REFERENCES

- 1.) Sanders, L. and Kelly, P. N., "Selection of Materials for Savannah River Site Consolidated Incineration Facility (CIF)", International Conference on Incineration of Hazardous Radioactive Wastes, Knoxville, TN, May, 1989.
- 2.) Sorell, G., "Materials Problems and Requirements for Low Level Radioactive Waste Incinerators", 1991 Incineration Conference, Knoxville, TN, May 13-17, 1991.
- 3.) Holmes, H. H. and Burns, D. B., "Testing to Reduce Salt Loading Via Wet Scrubbing", 1990 Incineration Conference, San Diego, CA, May, 1990.

TABLE 1. AQUEOUS WASTE BASE SIMULANT FOR CIF TRIALS

<u>Compound</u>	<u>Weight Percent</u>
K <sub>2</sub> CO <sub>3</sub>	5.0
H <sub>2</sub> O	95.0

TABLE 2. METAL NITRATE SPIKING SOLUTION #1

<u>Compound Additive</u>	<u>Weight Percent</u>
Be(NO <sub>3</sub> ) <sub>2</sub> ·3H <sub>2</sub> O	0.26
Cd(NO <sub>3</sub> ) <sub>2</sub> ·4H <sub>2</sub> O	0.09
Cr(NO <sub>3</sub> ) <sub>3</sub> ·9H <sub>2</sub> O	8.82
Pb(NO <sub>3</sub> ) <sub>2</sub>	1.41
Hg <sub>2</sub> (NO <sub>3</sub> ) <sub>2</sub> ·2H <sub>2</sub> O	0.14
Ni(NO <sub>2</sub> ) <sub>2</sub> ·6H <sub>2</sub> O	26.06
AgNO <sub>3</sub>	0.01
TiNO <sub>3</sub>	0.01
H <sub>2</sub> O	61.24
HNO <sub>3</sub> (conc.)	1.96

TABLE 3. METAL CHLORIDE SPIKING SOLUTION #2

<u>Compound Additive</u>	<u>Weight Percent</u>
SbCl <sub>3</sub>	38.74
As <sub>2</sub> O <sub>5</sub>	1.29
BaCl <sub>2</sub> ·2H <sub>2</sub> O	0.24
CuCl <sub>2</sub> ·2H <sub>2</sub> O	3.13
SeO <sub>3</sub>	0.19
H <sub>2</sub> O	31.34
HCl (conc.)	25.07

TABLE 4. ANALYSIS: PLUGGAGE MATERIAL FROM QUENCH TOWER NOZZLES

<u>Element</u>	<u>Weight Percent</u>
Si	77.65
K	9.05
Ca	6.28
Fe	4.15
Na	1.02

Note: Analysis by energy dispersive x-ray spectroscopy

TABLE 5. LABORATORY CORROSION TEST RESULTS FROM BLEND TANK SOLUTIONS

	Corrosion Rate after 10 days $\mu\text{m}/\text{y}$ (mpy)	Corrosion Rate after 31 days $\mu\text{m}/\text{y}$ (mpy)	Corrosion Rate after 60 days $\mu\text{m}/\text{y}$ (mpy)
Tank #1 (sample A) upper phase	1.4-1.8 (0.054-0.070)	2.8-3.1 (0.111-0.124)	1.4-1.6 (0.055-0.063)
lower phase	226 (8.90)	149 (5.85)	114 (4.51)
Tank #1 (sample B) (< 0.1 % water, pH ~3)	*	0.2 (0.008)	0.5 (0.02)
Tank #2 (< 0.1 % water, pH ~3)	0.02 (0.0006)	0.3 (0.011)	*
Tank #3	0.3 - 0.7 (0.011-0.027)	0.4 - 0.6 (0.016-0.024)	0.3 (0.011)

Note: \* samples gained weight. All coupons were ASTM A-36 steel. ASTM A-516 steel, used in tank construction, was not obtainable at the start of tests.

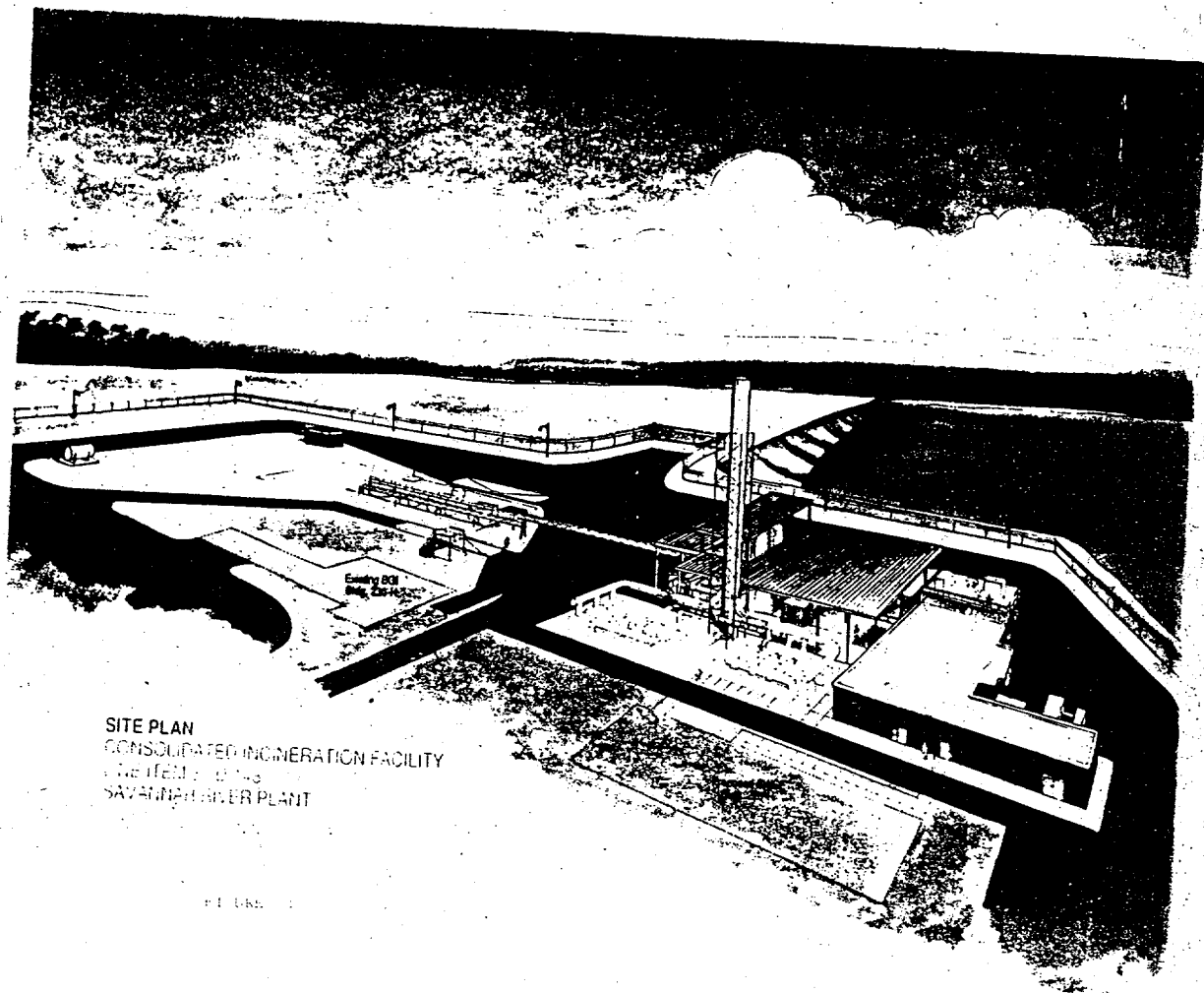

SITE PLAN  
CONSOLIDATED INCINERATION FACILITY  
INTEGRATING  
SAVANNAH WATER PLANT

SEE L&E

Figure 1. Conceptual Plan for the Consolidated Incinerator Facility

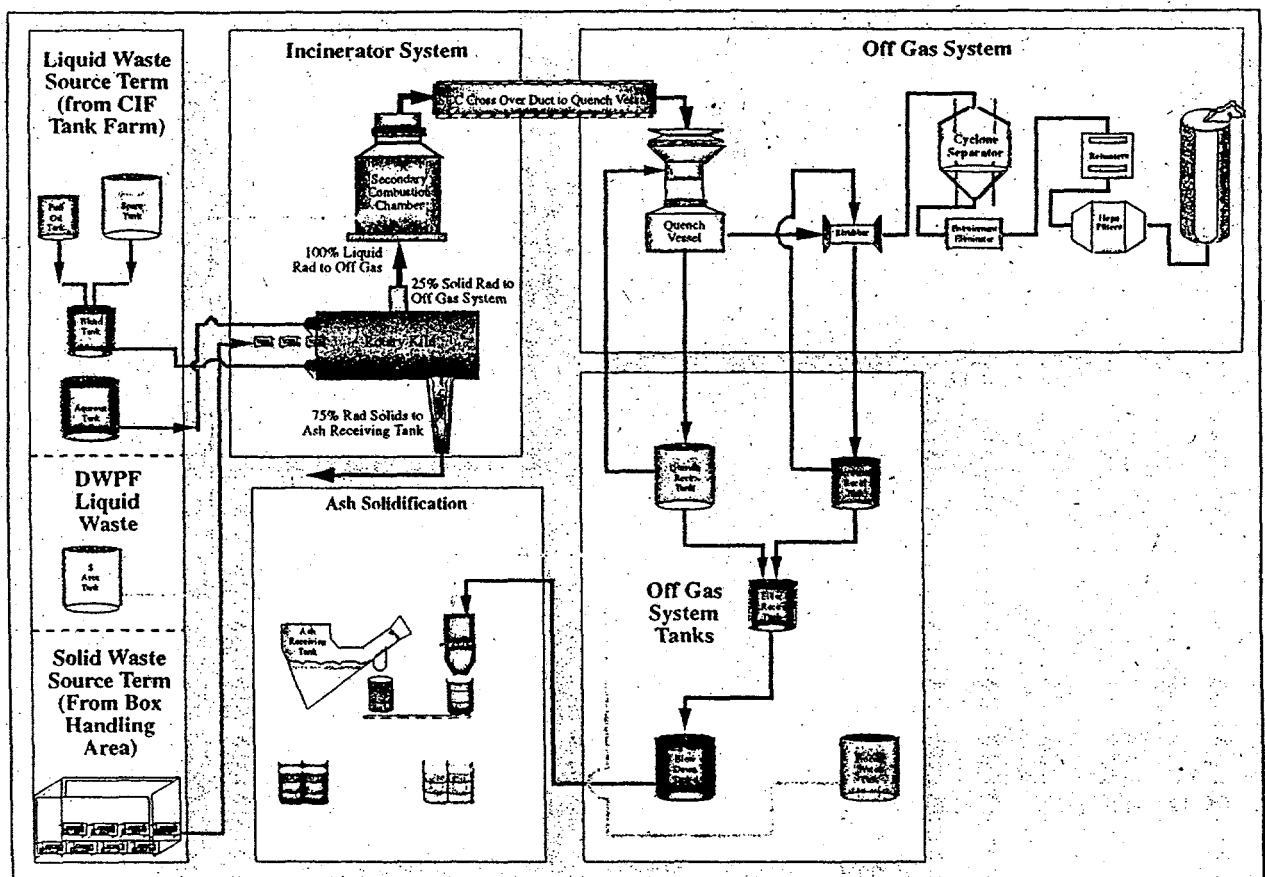

Figure 2. Process flow diagram for the Consolidated Incinerator Facility

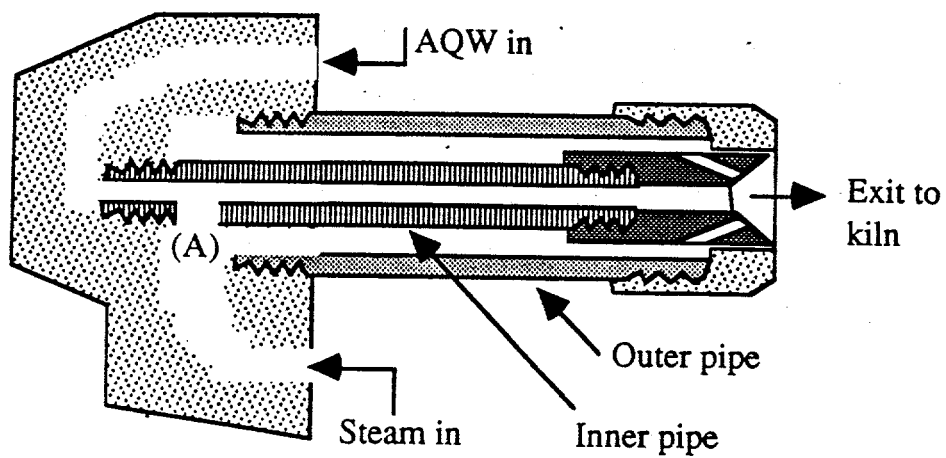

Figure 3. Injection gun arrangement. Location (A) identifies the area of steam impingement and location of the failure in the carbon steel pipe. Not to scale.

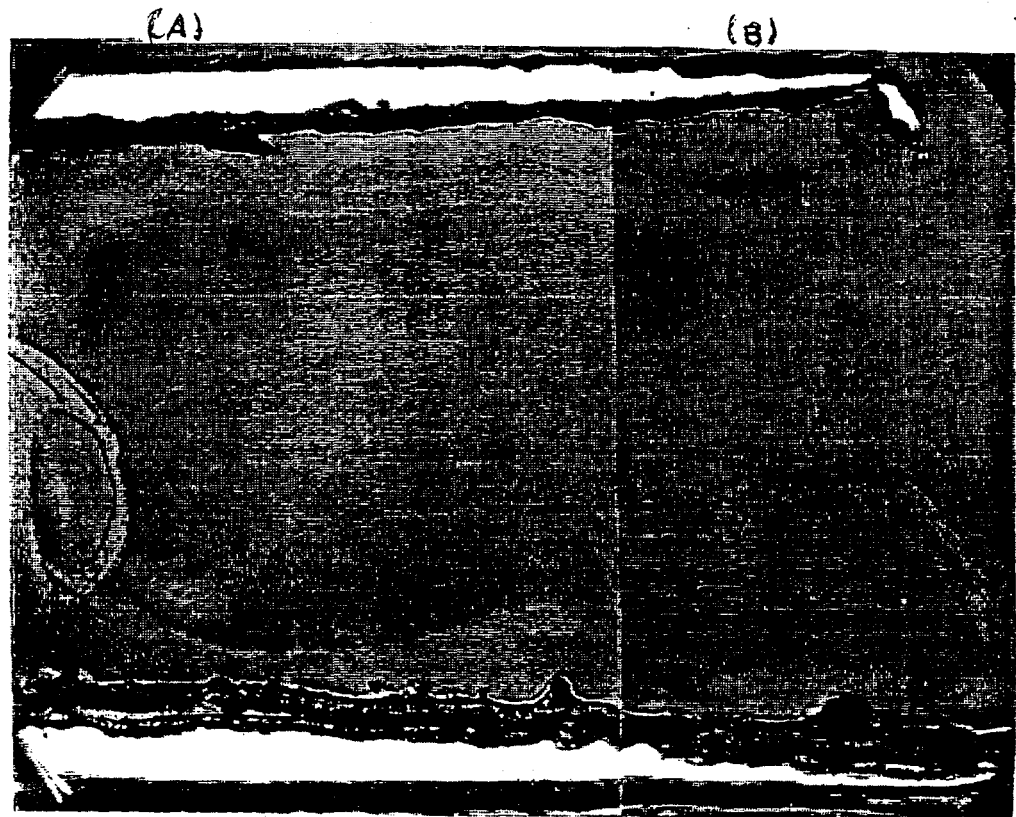
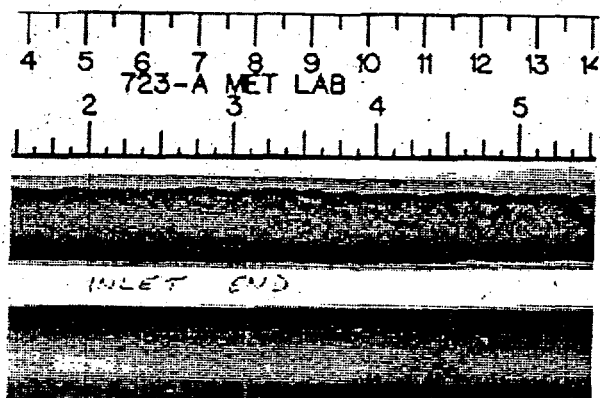
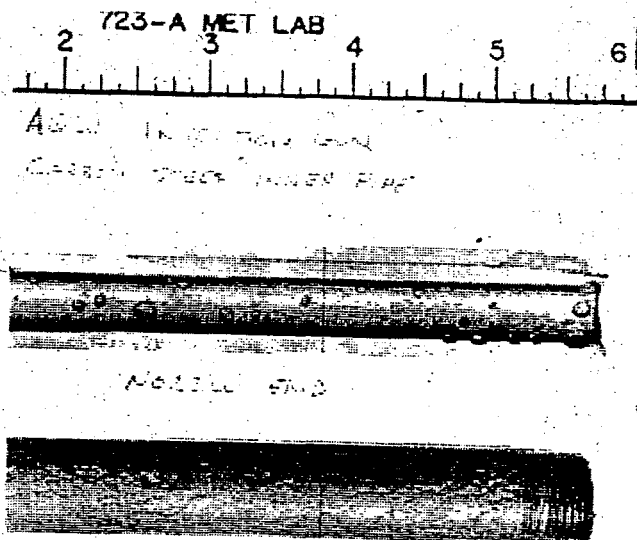

Figure 4. Axial cross section through the carbon steel inner pipe, 1.3 cm (0.8 in. OD), of the AQW injection gun. The edge of the leak location is at the upper right corner (B). Note the wall thinning on the OD in this area (B) compared with the original smooth surface at (A). Also note ID thinning due to corrosion elsewhere.



AQW INJECTION GUN  
CARBON STEEL INNER PIPE



(a) inlet end

(b) nozzle end

Figure 5. Cross sections of the carbon steel inner pipe of the AQW injection nozzle taken near the inlet end (a) and from the nozzle (b). Each photo shows the ID and OD surfaces. All deposits and corrosion products have been removed. Wall thinning and pitting are evident on the ID surfaces.

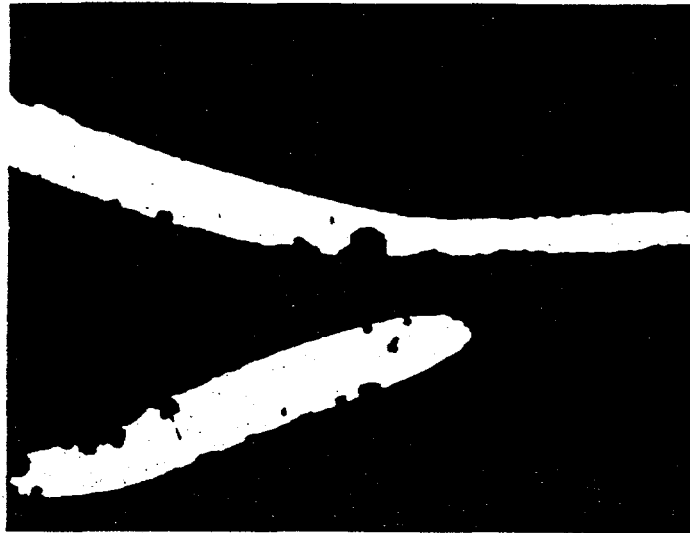

Figure 6 Pitting corrosion in HEPA pre-filter wire. (0.1 mm wire, stainless steel)



Figure 7 HEPA pre-filter wire. Note that corrosion pitting extends across the thickness of the stainless wire (0.1 mm).

WSRC-MS-96-0754



15

Figure 8. View of the pre-filter manway on HEPA housing. Major cracks occur on the shielding (arrows).

1. (SPR-MS-96-0754



Figure <sup>9</sup>~~7~~. Crack (arrow) in tack weld used to fasten interior baffle wall to the floor in the HEPA housing.

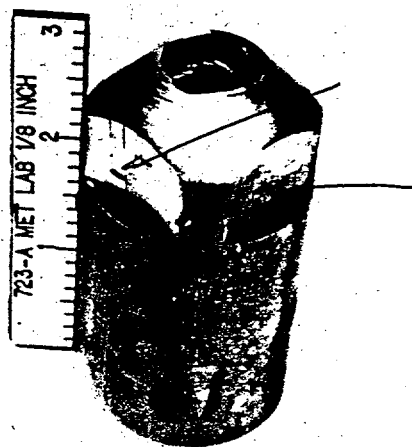

a.)

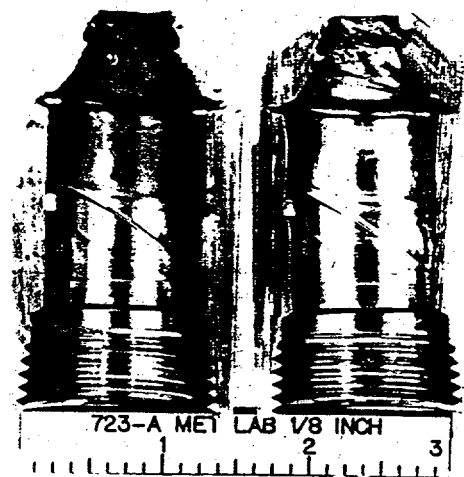

b.)

(a)

(b)

Figure 10. Quench spray nozzles showing through wall holes in (a). Inside appearance (b) shows channels eroded on the wall. Thinning in the channels led to the penetrations in (a)

115 SRC-MS-96-0754

Listing of Tables and Figures

TABLE 1. AQUEOUS WASTE BASE SIMULANT FOR CIF TRIALS

TABLE 2. METAL NITRATE SPIKING SOLUTION #1

TABLE 3. METAL CHLORIDE SPIKING SOLUTION #2

TABLE 4. ANALYSIS: PLUGGAGE MATERIAL FROM QUENCH TOWER NOZZLES

TABLE 5. LABORATORY CORROSION TEST RESULTS FROM BLEND TANK SOLUTIONS

FIGURE 1. Conceptual Plan for the Consolidated Incinerator Facility

FIGURE 2. Process flow diagram for the Consolidated Incinerator Facility

FIGURE 3. Injection gun arrangement. (A) identifies the area of steam impingement and location of the failure in the inner carbon steel pipe. Not to scale.

FIGURE 4. Axial cross section through the failed carbon steel inner pipe, 1.3 cm OD (0.8 in.), of the AQW injection gun. The edge of the leak location is at the upper right (B). Note wall thinning on the OD at (B) compared with the original smooth outer surface at A). Also note general ID thinning due to corrosion by the feed solutions.

FIGURE 5. Cross sections of the carbon steel inner pipe of the AQW injection nozzle from the inlet end (a) and from the nozzle end (b). Each photo shows the ID and OD surfaces. All deposits and corrosion products have been removed. Wall thinning and pitting are evident on the ID surfaces.

FIGURE 6. Pitting corrosion in HEPA pre-filter wire. (0.1 mm wire, stainless steel)

FIGURE 7. HEPA pre-filter wire. Note that corrosion pitting extends across the thickness of the stainless wire (0.1 mm).

FIGURE 8. View of the pre-filter manway on HEPA housing. Major cracks occur on the shielding (arrows).

FIGURE 9. Crack (arrow) in tack weld used to fasten interior baffle wall to the floor in the HEPA housing.

FIGURE 10. Quench spray nozzles showing through-wall holes in (a). Inside appearance (b) shows channels eroded on the wall. Thinning in the channels led to the penetrations in (a).