

UNCLASSIFIED

NAA-SR-283

REACTORS-POWER

LEGAL NOTICE

This report was prepared as an account of Government sponsored work. Neither the United States, nor the Commission, nor any person acting on behalf of the Commission:

A. Makes any warranty or representation, express or implied, with respect to the accuracy, completeness, or usefulness of the information contained in this report, or that the use of any information, apparatus, method, or process disclosed in this report may not infringe privately owned rights; or

B. Assumes any liabilities with respect to the use of, or for damages resulting from the use of any information, apparatus, method, or process disclosed in this report.

As used in the above, "person acting on behalf of the Commission" includes any employee or contractor of the Commission to the extent that such employee or contractor prepares, handles or distributes, or provides access to, any information pursuant to his employment or contract with the Commission.



UNCLASSIFIED

UNITED STATES ATOMIC ENERGY COMMISSION

A CONCEPTUAL DESIGN OF A THORIUM - URANIUM (233) POWER BREEDER REACTOR

By
J. O. Henrie
E. F. Weisner

February 1, 1954

North American Aviation, Inc.
Downey, California

Technical Information Service Extension, Oak Ridge, Tenn.

Price \$ 1.20

Available from the
Office of Technical Services
Department of Commerce
Washington 25, D. C.

DISCLAIMER

This report was prepared as an account of work sponsored by an agency of the United States Government. Neither the United States Government nor any agency thereof, nor any of their employees, makes any warranty, express or implied, or assumes any legal liability or responsibility for the accuracy, completeness, or usefulness of any information, apparatus, product, or process disclosed, or represents that its use would not infringe privately owned rights. Reference herein to any specific commercial product, process, or service by trade name, trademark, manufacturer, or otherwise does not necessarily constitute or imply its endorsement, recommendation, or favoring by the United States Government or any agency thereof. The views and opinions of authors expressed herein do not necessarily state or reflect those of the United States Government or any agency thereof.

DISCLAIMER

Portions of this document may be illegible in electronic image products. Images are produced from the best available original document.

~~SECRET~~

UNCLASSIFIED

NAA-SR-283



NO. 41211

A CONCEPTUAL DESIGN OF A
THORIUM-URANIUM (233) POWER
BREEDER REACTOR

WRITTEN BY:

J. O. HENRIE
E. F. WEISNER

WORK DONE BY:

J. O. HENRIE
M. A. MADISON
M. F. MOORE
E. F. WEISNER

CLASSIFICATION CANCELLED

DATE MAR 1 1957

For The Atomic Energy Commission

H. F. Canale
Chief, Declassification Branch TC

ATOMIC ENERGY RESEARCH DEPARTMENT
NORTH AMERICAN AVIATION, INC.
P. O. BOX 309 DOWNEY, CALIFORNIA

SUBMITTED: NOVEMBER 2, 1953

ISSUE DATE

FEBRUARY 1, 1954

CONTRACT AT 11-1-GEN-8

UNCLASSIFIED

DECLASSIFIED

~~SECRET~~

4817



REPORT APPROVED BY:

R. L. OLSON, Group Leader, Design

W. E. ABBOTT, Group Leader, Engineering Analysis

W. E. PARKINS, Group Leader, Reactor Engineering

S. SIEGEL, Associate Director

C. STARR, Director

DISTREACTORS-RESEARCH
AND POWER

Standard Distribution	Copy No.
AF Plant Representative, Burbank	1
AF Plant Representative, Seattle	2
AF Plant Representative, Wood-Ridge	3
ANP Project Office, Fort Worth	4
Argonne National Laboratory	5-15
Armed Forces Special Weapons Project (Sa	16
Armed Forces Special Weapons Project, W	17
Atomic Energy Commission, Washington	18-22
Battelle Memorial Institute	23
Brookhaven National Laboratory	24-26
Bureau of Ships	27
California Patent Group	28
California Research and Development Company	29-30
Carbide and Carbon Chemicals Company (ORNL)	31-38
Carbide and Carbon Chemicals Company (Y-12 Pl	39-44
Chicago Patent Group	45
Chief of Naval Research	46
Commonwealth Edison Company	47
Department of the Navy - Op-362	48
Detroit Edison Company	49
duPont Company, Augusta	50-54
duPont Company, Wilmington	55
Foster Wheeler Corporation	56
General Electric Company (ANPP)	57-59
General Electric Company, Richland	60-63
Hanford Operations Office	64
Iowa State College	65
Knolls Atomic Power Laboratory	66-69
Los Alamos Scientific Laboratory	70-71
Massachusetts Institute of Technology (Kaufmann)	
Monsanto Chemical Company	
Mound Laboratory	
National Advisory Committee for Aeronautics, Cleveland	
National Advisory Committee for Aeronautics, Washington	
Naval Research Laboratory	
New York Operations Office	
Nuclear Development Associates, Inc.	
Patent Branch, Washington	
Phillips Petroleum Company	
Powerplant Laboratory (WADC)	
Pratt & Whitney Aircraft Division (Fox Project)	
Rand Corporation	
San Francisco Field Office	9
Sylvania Electric Products, Inc.	93
USAF Headquarters	94
U. S. Naval Radiological Defense Laboratory	95
University of California Radiation Laboratory, Berkeley	96-9
University of California Radiation Laboratory, Livermore	98-9
Walter Kidde Nuclear Laboratories, Inc.	100
Westinghouse Electric Corporation	101-106
Technical Information Service, Oak Ridge	107-121
File	122-150

← TAPE



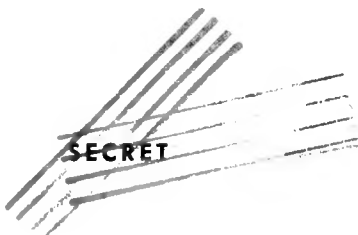

TABLE OF CONTENTS

	Page No.
Abstract	5
I. Introduction	7
II. Discussion	8
A. General Arrangement	8
B. Moderator and Reflector Elements	9
C. Fuel Elements	10
D. Core Tank	11
E. Core Cooling System	11
F. Control Rods	12
G. Safety Rods	13
H. Thermal Shield and Insulation	13
I. Foundation, Shielding, and Shield Cooling	15
J. Building and Plant Layout	16
III. Conclusion	17
References	41

LIST OF TABLES

I. Physical and Nuclear Characteristics	18
II. Heat Transfer Characteristics (Rated Power)	19





LIST OF FIGURES

	Page No.
1. Conversion Ratio <u>vs</u> Rated Power.	20
2. Conversion Ratio <u>vs</u> Fraction U^{233} in Thorium	21
3. General Arrangement.	23
4. Plant Layout	25
5. Core Element	27
6. Fuel Element	29
7. Control and Safety Rod Drive System	31
8. Control Rod	33
9. Safety Rod	35
10. Upper Biological Shield, Beam Type.	37
11. Building Arrangement	39

03728030



ABSTRACT

A conceptual design study has been performed for a sodium cooled, graphite moderated, thermal power-breeder reactor utilizing the Th-U²³³ breeding cycle. Several aspects of the design of the system are considered but no attempt has been made to supply all the details. It appears that the design presented is feasible and will allow the production of economic power as well as full utilization of thorium resources.

This report is based upon studies conducted for the Atomic Energy Commission under Contract AT-11-1-GEN-8.

Blank Page



I. INTRODUCTION

A previous report¹ described a general survey study conducted on Th-U²³³ power breeder reactors. In that report the economic advantages of such a reactor were established as well as its ability to utilize essentially 100 per cent of the thorium supply. An underlying assumption was made that the study consider only those designs which are within the scope of engineering feasibility at the present time. It is the intent of this report to describe a conceptual design based on one of the cases studied in Ref. 1.

The case selected is a 1000 megawatt unit employing a square lattice with 8 inches between adjacent elements. The fuel elements consisted of seven 3/4-inch diameter Th-U²³³ rods clad in zirconium of 0.020-inch wall thickness. There may need to be a thin (0.005 inch) bonding layer of either sodium or NaK between the thorium and the zirconium tube. If a satisfactory metallurgical bond can be obtained between the thorium and zirconium, the sodium or NaK bonding layer can be omitted. Since this depends upon future developments, the use of a bonding layer has been used in this study. The seven rod element is hung vertically within a 0.035 inch wall zirconium coolant channel. Each cell of the moderator is also contained within a thin walled (approximately 0.035 inch) zirconium can so that any sodium penetration of the graphite due to a coolant channel failure will be localized to one cell.

The pertinent physical and nuclear data for this reactor are listed in Table I while Table II lists the heat transfer characteristics. Figures 1 and 2 are reproduced from Ref. 1 with the selected design point indicated.

There is, of course, a start-up problem with any Th-U²³³ reactor since U²³³ does not occur naturally. Reference 1 discusses this problem in considerable detail. Four possible methods are discussed. They are as follows:

1. Produce the required amount of U²³³ in a special U²³³ production facility.
2. Produce the U²³³ in the breeder itself using slightly enriched uranium and thorium, stockpiling the U²³³ until enough has been produced.



steel thermal shield and about 7 feet of heavy concrete biological shield. The slabs contain vertical holes on 8 inch centers through which the fuel is loaded and unloaded. The 24 control and 12 safety rods operate in regular fuel channels (which, of course, contain no fuel). The control and safety rods are driven from units located below the upper surface and near the ends of the shielding slabs. The rods operate within thimbles which extend down inside the coolant channels so as to exclude sodium and sodium vapor from the drive mechanism. The safety rods fall by gravity and are stopped by a sealed shock absorbing mechanism.

The core cooling system consists of 16 parallel primary coolant (sodium) loops and 8 individual secondary coolant (sodium or NaK) loops each having two pumps and heat exchangers in parallel. Eight separate 125 megawatt steam generator units are used to drive two 150 electrical megawatt turbo-generators. A preliminary plant layout is shown in Fig. 4.

B. Moderator and Reflector Elements

A typical canned moderator element is shown in Fig. 5. The canned reflector elements are similar except they do not have a fuel tube or a guide tube at the upper end.

The elements are graphite contained within a zirconium can. The can wall and coolant tube wall thickness is 35 mils. There is a 15 mil gap between the graphite and can wall and a 5 mil radial gap between the coolant tube and the graphite. The gaps allow for thermal expansion, radiation growth and necessary clearance for assembly.

The coolant tube is swaged to 3-1/4 inches inside diameter at the upper end to fit a sleeve which connects to a perforated stainless steel guide tube which has been annealed or normalized to minimize warping. The sleeve should be made of a material which will not self weld or gall when in contact with the guide tube and sodium at temperatures up to 1200° F. Pilot plant experience may indicate that guide tubes are not needed and therefore any problems associated with guide tube warping and galling will be eliminated.

A stainless steel indexing and supporting fixture fits into the lower end of the moderator elements. Orifice holes are provided in the fixture to allow the appropriate amount of coolant to flow up along the outside of the canned



elements. If the space between the cans become plugged with oxides or foreign material, or by the cans expanding and closing the coolant passages between them, the pressure on the bottom of the can would cause it to float. However, if the space between cans is maintained at $3/32$ inch, the can will not float but will exert a 250 pound downward force on its support when operating at the design power level. If the space between cans were increased to $1/8$ inch, the net downward force would be 315 pounds. However, if a higher factor of safety against the can floating were desired, it would probably be better to add more weight to the can then to increase the spacing above $3/32$ inch. By installing properly designed filters and cold traps in the primary cooling systems, the problem of the space between the cans being plugged with oxides or foreign materials will be minimized. If the gas pressure inside the can is below atmospheric, the can walls will remain collapsed against the graphite blocks. Therefore, before sealing the cans, they should be outgassed by evacuating at a high temperature, and an inert gas bled in until desired pressure is reached. This pressure would be low enough so that the final pressure due to temperature rise and irradiation for the expected life of the reactor would not exceed 1 atmosphere absolute.

C. Fuel Elements

The fuel elements are made in 7 rod clusters 10 feet long. Each fuel rod is 0.800 inch OD, including a 20 mil tubular shell of zirconium and a 5 mil sodium bond around the $3/4$ -inch diameter thorium-uranium rod. The rods are firmly pinned together at the upper end and are guided at the lower end by a spider. The spider is fastened only to the central rod and allows independent vertical movement of the lower end of each rod. The rods are laterally supported by an arrangement of short deformed tubes, wire and bands at three places along the element. A conical flow restricting device and fuel guide is mounted below the spider at the lower end of the fuel element. The flow restricting device is required to control the flow in a particular channel in accordance with the power produced in the channel.

A typical fuel element is shown in Fig. 6. Each fuel element is suspended from the hanger rod and shield plug by the quick disconnect and short hanger rod shown.



D. Core Tank

A core tank is required to index and support the core elements and to confine the core coolant. The tank is supported on the lower thermal shield which is vertically supported on carbon blocks and laterally supported by steel rings as shown in Fig. 3.

The tank is made from 1-inch thick austenitic stainless steel plate. The lower tubesheet is made from the same material and is attached to the tank bottom by welding to pins which extend from the tank bottom up through holes in the tubesheet. The tubesheet is also welded to the tank wall. These welds need not be leak tight since some of the coolant is bypassed across the tubesheet to cool the outside surface of the canned elements and the tank wall. A number of small leaks would not add significantly to the amount of coolant bypassed.

The upper end of the tank is sealed to a steel liner at the lower side of the beam type shield slabs by a flexible seal. This seal is made up of specially rolled rings approximately 24 feet diameter welded to form a large bellows. The seal is flexible to allow for thermal expansion in the tank.

The coolant pipes are welded to the tank wall at a level about 16 feet above the tank bottom. When the system is heated up, the coolant pipes apply a compression load to the tank. The bends in the piping reduce the loads and stresses, but counter weights and spring supports will also be required to reduce the loads on the tank. If necessary, the tank could be laterally supported at its upper end by hinge arrangements which allow radial and vertical movement but resist lateral movement.

E. Core Cooling System

To contain the radioactive coolant in as small an area as possible and away from the steam generator units, the core cooling system is divided into primary and secondary cooling systems which are coupled by intermediate heat exchangers. There are 16 parallel primary loops. The coolant in each loop leaves the core tank through a 14-inch pipe, which has appropriately located bends to reduce stresses, and enters the lower end of a vertically mounted centrifugal pump. It leaves the pump through a 12-inch pipe and enters a



vertically mounted (KAPL hockey stick type) intermediate heat exchanger at the lower end. It flows from the upper end of the exchanger in a 12-inch pipe back to the reactor core tank at a level just above the top of the canned core elements. The 12-inch pipe is reduced to an 8-inch pipe which runs down the inside of the tank, through the lower tubesheet and ends. The coolant flows through the core and into the reservoir above the core to complete the circuit. To reduce thermal stresses and heat loss, a 10-inch cover pipe shields the 8-inch pipe from the high temperature coolant. The pipe is reduced in size so that it will not interfere with the reflector any more than is necessary. The coolant velocity in most of the system is between 10 and 15 feet per second. In the 8-inch downcomer it is 30 feet per second. This increases the total flow resistance of the loop and therefore the pumping power approximately 15 per cent above what it would be if the downcomer were made of 12-inch pipe.

The secondary cooling system transfers the heat from the primary coolant to the steam generators. The 16 horizontally mounted centrifugal pumps are located in the cold legs of the loops. There are eight steam generators each having a capacity of 125 megawatts and each receiving coolant from two pumps and primary heat exchangers placed in parallel. The superheated steam from the generators drives two 150 electrical megawatt turbogenerator units.

F. Control Rods

The reactor has 24 vertical control rods located as shown in Fig. 7. A detail of the rod is shown in Fig. 8.

Constant speed drive units located near one end and slightly below the surface of the beam type shield slab turn horizontal shafts and worms which actuate worm gears attached to vertical Saginaw type screws. In the central beam slab each drive unit operates three control rods and in adjacent slabs each unit operates two control rods. As the vertical screw turns, it raises or lowers a ball nut. The nut is restrained from turning with the shaft by guide pins and grooves in the guide tube. A pull tube connects the ball nut to the control rod.

The control rod is made up of a stainless steel tube with boron steel rings surrounding it. The rod operates in a thimble which extends down through the reactor core inside a regular coolant channel. The rod is cooled by



conduction and radiation across a 20 mil helium annulus between the boron steel rings and the thimble. The thimble wall is cooled by the sodium coolant flowing up the annulus between the thimble and the coolant tube. The major purpose of the thimble is to exclude sodium and sodium vapors from the drive mechanisms.

The position of a control rod in the reactor is indicated by a counting device attached to the drive motor. The position of the control rod can be indicated by measuring the number of revolutions the drive motor has made since the motor is connected to the rod through gears.

G. Safety Rods

The safety rod drive system is similar to that of the control rods except (1) the drive units are located at the opposite end of the beam slabs; (2) the horizontal drive shafts are 4 inches below those of the control rods; (3) each drive unit and shaft actuates only one safety rod; (4) a latch mechanism is incorporated in the Saginaw nut to release the safety rod and allow it to fall by gravity into a thimble extending down through the reactor core. See Fig. 9.

The safety rods are made of boron steel. Since the reactor shuts down when the safety rods go in, the cooling requirement for the safety rods is not as severe as it is for the control rods. Therefore, the helium annulus between the safety rod and the sodium cooled thimble is considerably larger than for the control rods.

A bellows sealed liquid metal shock absorber is located in the lower end of the thimble to decelerate and absorb the energy of the falling safety rod. This is also shown in Fig. 9.

H. Thermal Shield and Insulation

The thermal shield adjacent to the tank wall is made of mild steel slabs 3 inches thick, 12 inches wide and 25 feet long. They are vertically supported at their lower end by a pad which rests on carbon blocks. They are laterally supported at their ends and centers by rods extending into the concrete foundation. The rods extend through slotted holes in the slabs which allow for thermal expansion upward. The slabs overlap resulting in a 6-inch thermal shield thickness. The 6-inch thermal shield below the bottom of the tank rests



directly on carbon blocks. The outer portion consists of blocks 3 inches thick which overlap and are loosely pinned in place. The central section consists of two circular plates each 3 inches thick. The lower one is larger in diameter than the upper one and has beveled blocks welded to it which form a ring to index and laterally support the upper plate. The upper plate is bolted and pinned to the tank bottom and the lower one is laterally supported from the foundation by two concentric steel rings; thus, the central portion of the lower thermal shield locates and provides lateral support to the core tank.

The upper thermal shield is supported from the beam type shield slabs above it. It consists of mild steel blocks 8 inches square by 4 inches thick. The blocks above fuel channels have holes cut through them into which the lower ends of the hole plugs fit.

Thermal insulation is placed between the thermal shield and biological shield or foundation wall to keep the heat losses to a minimum. Therefore, most of the heat generated in the thermal shield is radiated or conducted back to the core tank and liquid metal coolant. The estimated temperature of the thermal shield at different locations ranges from 500° F below the reactor to 1210° F in the central portion of the upper thermal shield. The thickness and type of insulation material selected allows an average of approximately 400 Btu/hr ft² to flow across it. This is less than 15 per cent of the estimated heat produced in the thermal shield and amounts to a total of 390 kilowatts or 0.04 per cent of the total heat produced.

The insulation material tentatively selected for the area below the lower thermal shield is carbon block. Carbon block was chosen because of its compatibility with sodium (in case of an accident) at the temperatures involved, its load bearing characteristics and low cost. The insulation material selected for the area between the side thermal shield and the foundation wall is Johns Manville Type LK-61 or an equivalent sodium and radiation resistant, rigid insulation material.

Since the area above the upper thermal shield is exposed to sodium vapor, radiation type insulation consisting of stainless steel sheets was selected. The sheets are spaced approximately 1 inch apart to reduce the convection currents in the inert atmosphere between them. Sodium condensing on the sheets will drip back into the sodium pool. To prevent sodium from



freezing on the lower surface of the beam type shielding slabs, a gas tight layer of inert gas is enclosed by a thin stainless steel sheet welded to the lower surface of each beam.

I. Foundation, Shielding, and Shield Cooling

The foundation concrete is lined with a mild steel plate. Cooling tubes containing an organic coolant are welded to the steel liner to remove the heat conducted across the insulation and generated in the foundation concrete and steel liner. Since the reactor is entirely below ground, the earth and foundation concrete around the bottom and lower sides of the reactor provide adequate biological shielding. The foundation material is regular reinforced Portland concrete. The thickness and reinforcing requirements will depend on the subgrade conditions at the site and the concrete temperatures. An allowable design temperature of 150° F has been selected as a reasonable maximum.

The beam type shielding slabs above the reactor are shown in Fig. 10. There are seven beams, the central ones being 28 feet long, 4 feet wide, 7 feet deep and weighing approximately 125 tons each. Each beam consists of a dense concrete filled steel shell with vertical tubes above each fuel tube in the reactor. Because of its depth, it is very rigid and the stresses in the steel and concrete are low. The maximum deflection at the center of a beam is 0.20 inches. A 150 ton load (fuel transfer cask) at the center of the beam causes it to deflect 0.05 inch. The weight of the beam results in a deflection of 0.03 inch and a temperature differential of 75° F across the beam causes it to deflect 0.12 inch.

The stepped spaces between beams are filled with steel shim plates to reduce radiation leakage. They are sealed at the upper face by thin, flexible, U-shaped steel strips welded to the beams. The flexible seal allows the beams to deflect individually.

The smaller rectangular shielding plugs located at one end of each beam cover the shield coolant piping system. The coolant will become radioactive and should therefore be passed through an intermediate heat exchanger. The heat from the secondary coolant could be used for heating the buildings or dissipated in a cooling tower.



J. Building and Plant Layout

The reactor building is shown in Fig. 11. It houses the reactor, new fuel storage, control rooms, primary coolant system, the pumps and surge tanks of the secondary coolant system, and other gas and coolant storage and handling equipment.

The reactor room is 70 feet long, 30 feet wide and 50 feet high. This high bay area extends another 30 feet to a 50 foot long reactor facilities building where the spent fuel cleaning and storing is done. The high bay area is therefore 150 feet long. If necessary, it could be divided by special doors large enough to allow the traveling crane and fuel transfer cask to move freely from one area to the other.

The control rooms are located at one end of the reactor building. There are three rooms, each approximately 30 feet square by 15 feet high and located one above the other with a service elevator connecting them. Each room overlooks the reactor on one side and the outdoor turbine-generator units on the opposite side. The adjacent side of the two lower rooms overlook part of the primary and secondary sodium equipment.

Located on each side of the reactor room are the rooms containing the primary and secondary coolant equipment. Each of the two rooms is equipped with a 25 ton traveling crane used for installing, handling and repairing the equipment. The rooms are each 50 feet by 100 feet, making the entire reactor building approximately 100 feet by 130 feet.

The plant layout shown in Fig. 4 indicates that the basic area required for the plant is approximately 1000 feet square. The steam generator buildings are shown located 100 feet away from other structures because of the possible danger of explosion and fire. Each steam generator building houses four 125 megawatt steam generators. Only a minimum of equipment would be located in these buildings. The pumps, deaerators, feedwater heaters, exchangers, condensers, etc., would be located adjacent to the turbine-generator units. The turbine-generator units are located together for convenience and ease in installing and operating them. Their steam systems would be interconnected so that either turbine could be run from either group of steam generators. The major controlling units would be located in the control rooms in



the reactor building. A traveling crane would be mounted over them for installing and maintaining the turbine generators and equipment.

The condensers could be cooled with ocean or lake water, or by water passing through cooling towers. The ground area required for a sufficient number of 25 foot high, induced draft cooling towers is approximately 60,000 square feet. The towers would require approximately 5,000 gallons per minute makeup water when dissipating 700 megawatts.

III. CONCLUSION

It is believed that a feasible design has been described in this report which, when used with the Th-U²³³ cycle, can make possible economical production of useful electric power as well as the complete utilization of the thorium supply. The design has been carried through the conceptual stages only; it is recognized that a large number of details remain to be worked out.



TABLE I
PHYSICAL AND NUCLEAR CHARACTERISTICS

Diameter of active core	17 ft
Active length of fuel elements	10 ft
Number of fuel elements	508
Number of rods per element	7
Diameter of fuel rods	0.750 inch
Fuel rod cladding	0.020 inch zirconium
Coolant channel dimensions	3.000 inch ID by 0.035 inch wall zirconium
Lattice spacing	8.0 inches
Reflector thickness	approximately 30 inches
Thorium in core	35800 kg
U^{235} required for core for initial loading	1074 kg
U^{233} needed in core (1% K excess)	802 kg
Fraction U^{233} in thorium	0.0224
Initial conversion ratio (with U^{233})	1.10
Initial conversion ratio (with U^{235})	0.88
Estimated attainable burnup	20,000 to 30,000 mwd/t
Number of control rods	24
Number of safety rods	12
Average to peak cell power	0.56
Average thermal flux	$5 \times 10^{13} \frac{\text{neutrons}}{\text{cm}^2 \text{ sec}}$
Electrical power	300 megawatts
Electrical output at 80% plant factor	2.1×10^9 kWh/yr



TABLE II
HEAT TRANSFER CHARACTERISTICS (RATED POWER)

<u>Central Cell</u>	
Sodium inlet temperature	500° F
Sodium outlet temperature	850° F
Sodium velocity	15 ft/sec
Maximum thorium temperature	1800° F
Sodium flow rate	118,000 lbs/hr
Heat removal rate	3720 kw
<u>Reactor</u>	
Inlet temperature	500° F
Maximum outlet temperature	1000° F
Mixed mean sodium temperature	936° F
Sodium flow rate	25×10^6 lbs/hr
Total rated power	1000 megawatts
Throttle steam pressure	800 psig
Throttle steam temperature	825° F
Net power conversion efficiency	32.2%

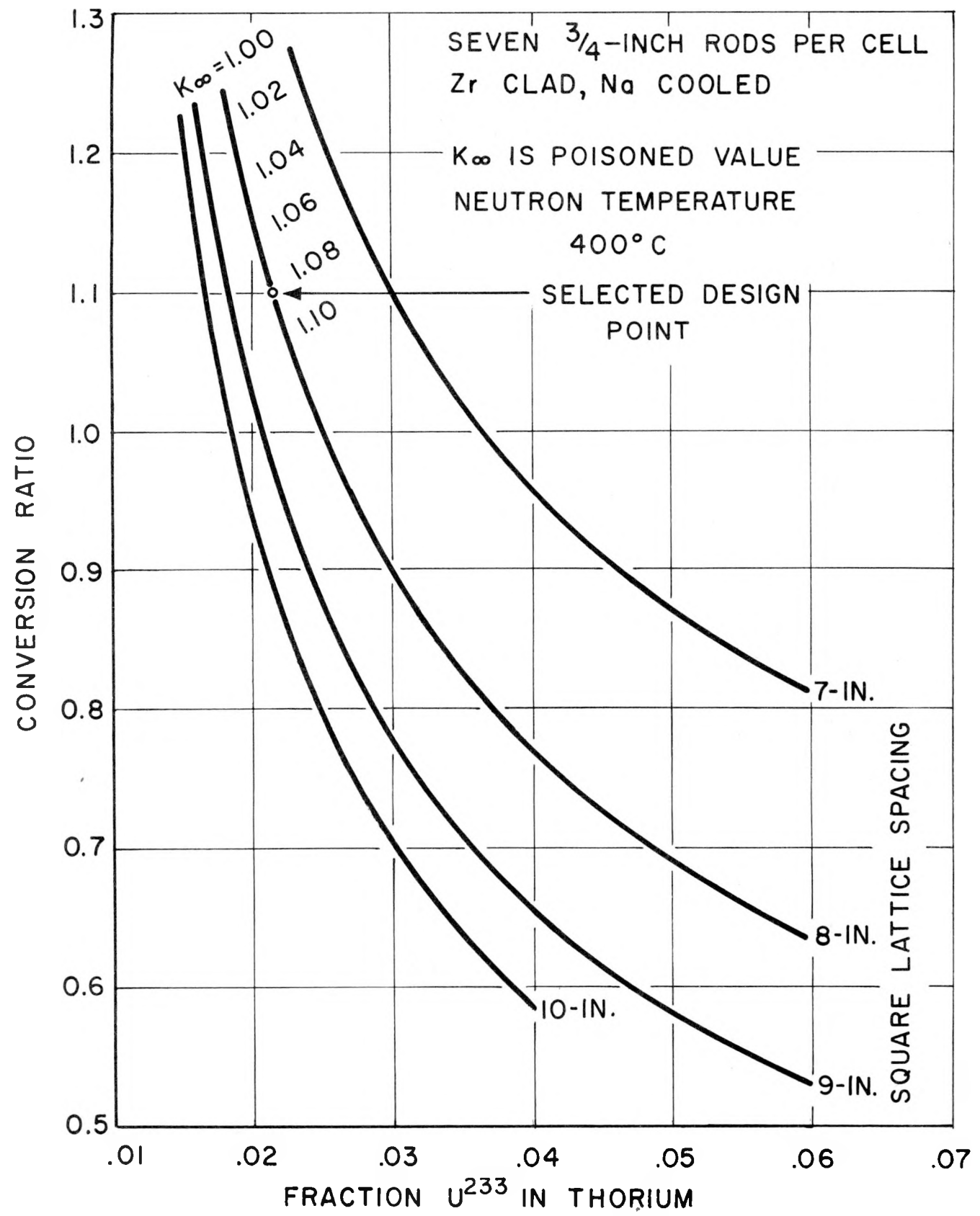

Fig. 2. Conversion Ratio vs Fraction U^{233} in Thorium

CONFIDENTIAL

22

23

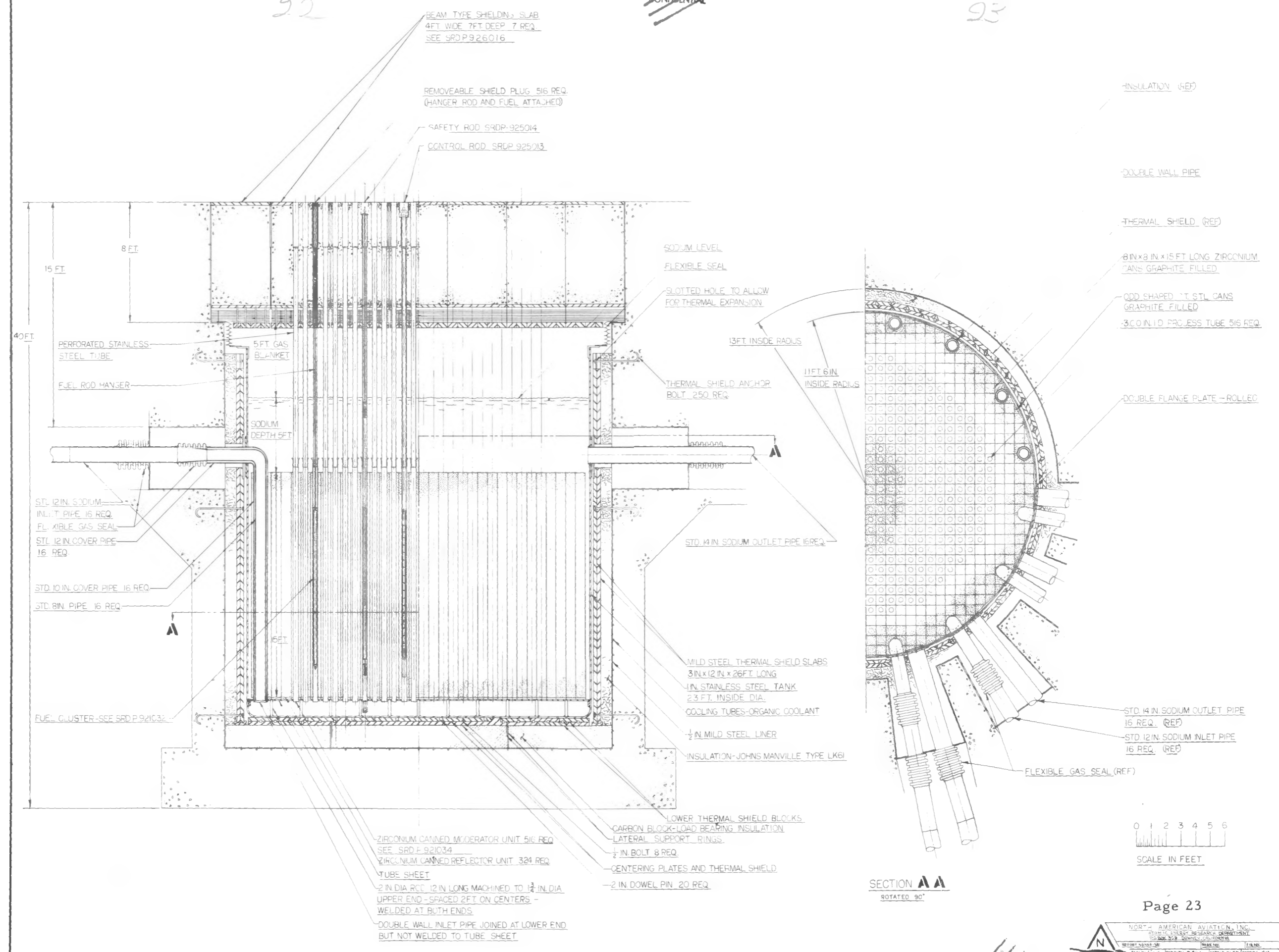

Fig. 3. General Arrangement

NORTH AMERICAN AVIATION, INC.
PLASTIC ENGINE RESEARCH DEPARTMENT
3000 BAY AVENUE, OAKLAND, CALIF. 94612

PROJECT NUMBER: SRDP 920025
DRAWING NUMBER: P-17 - GENERAL ARRANGEMENT
DATE: 11/23/65
BY: [Signature]
CHECKED: [Signature]

SRDP 920025

CONFIDENTIAL

CONFIDENTIAL

24

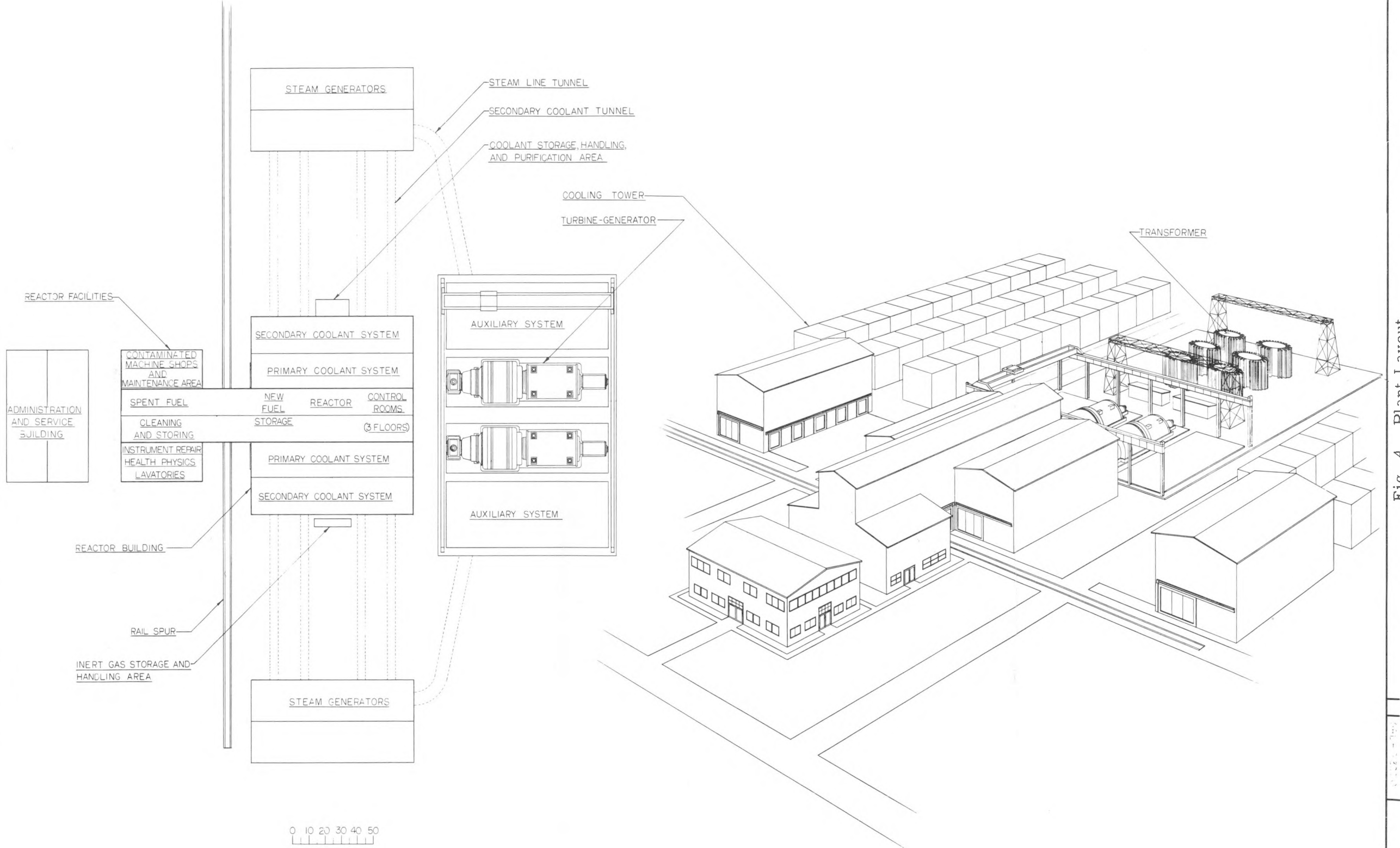

0 10 20 30 40 50
SCALE IN FEET

Fig. 4. Plant Layout

UNCLASSIFIED

UNCLASSIFIED



~~CONFIDENTIAL~~

28

29

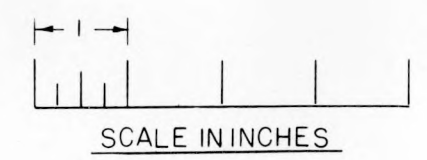
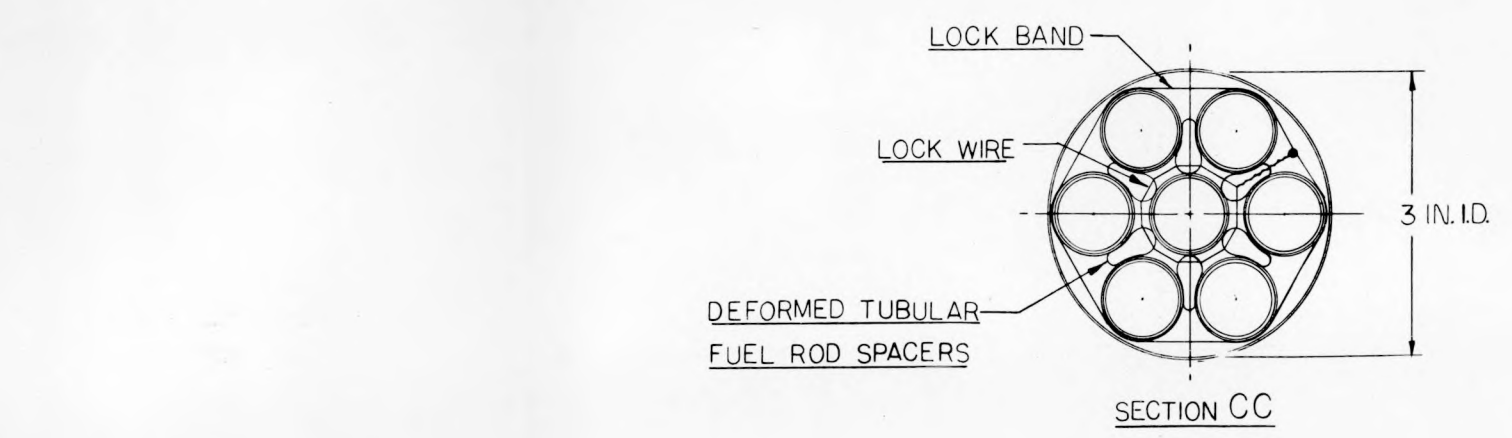
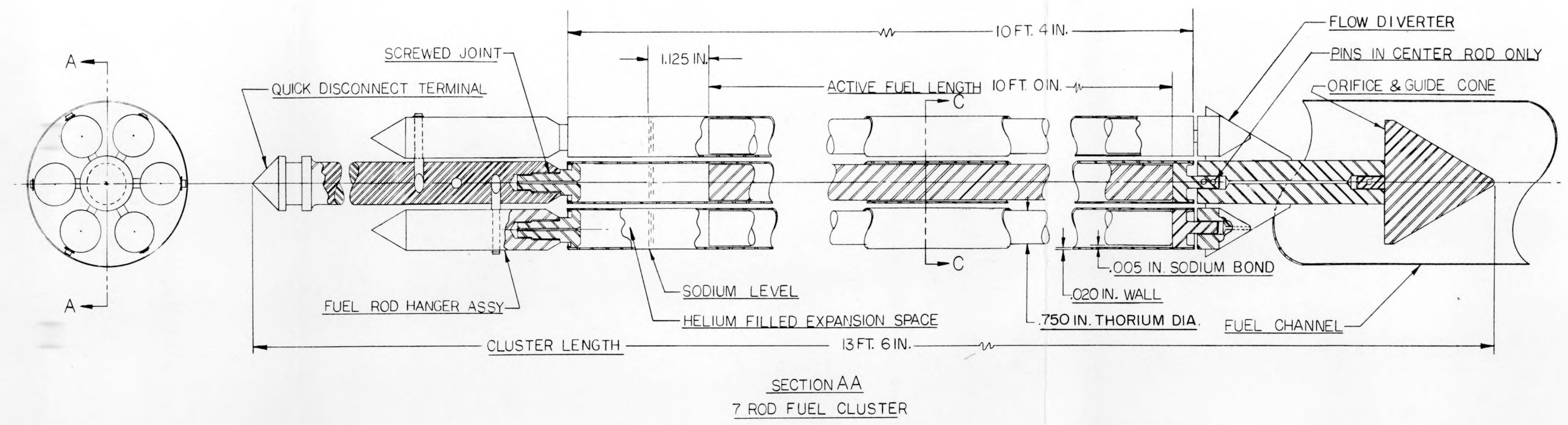

Fig. 6. Fuel Element

~~CONFIDENTIAL~~

NORTH AMERICAN AVIATION, INC.
 ATOMIC ENERGY RESEARCH DEPARTMENT
 P.O. BOX 308 DOWNY, CALIFORNIA

REPORT NO. NAA	MEMO	PAGE NO.	FIG. NO.
SCALE: FULL	DRAWN BY: HALTERS	DATE: 3/25/53	APPROV: [Signature]
P-17 FUEL ELEMENT			SRDP 921032

UNCLASSIFIED

UNCLASSIFIED

UNCLASSIFIED

30

UNCLASSIFIED

31

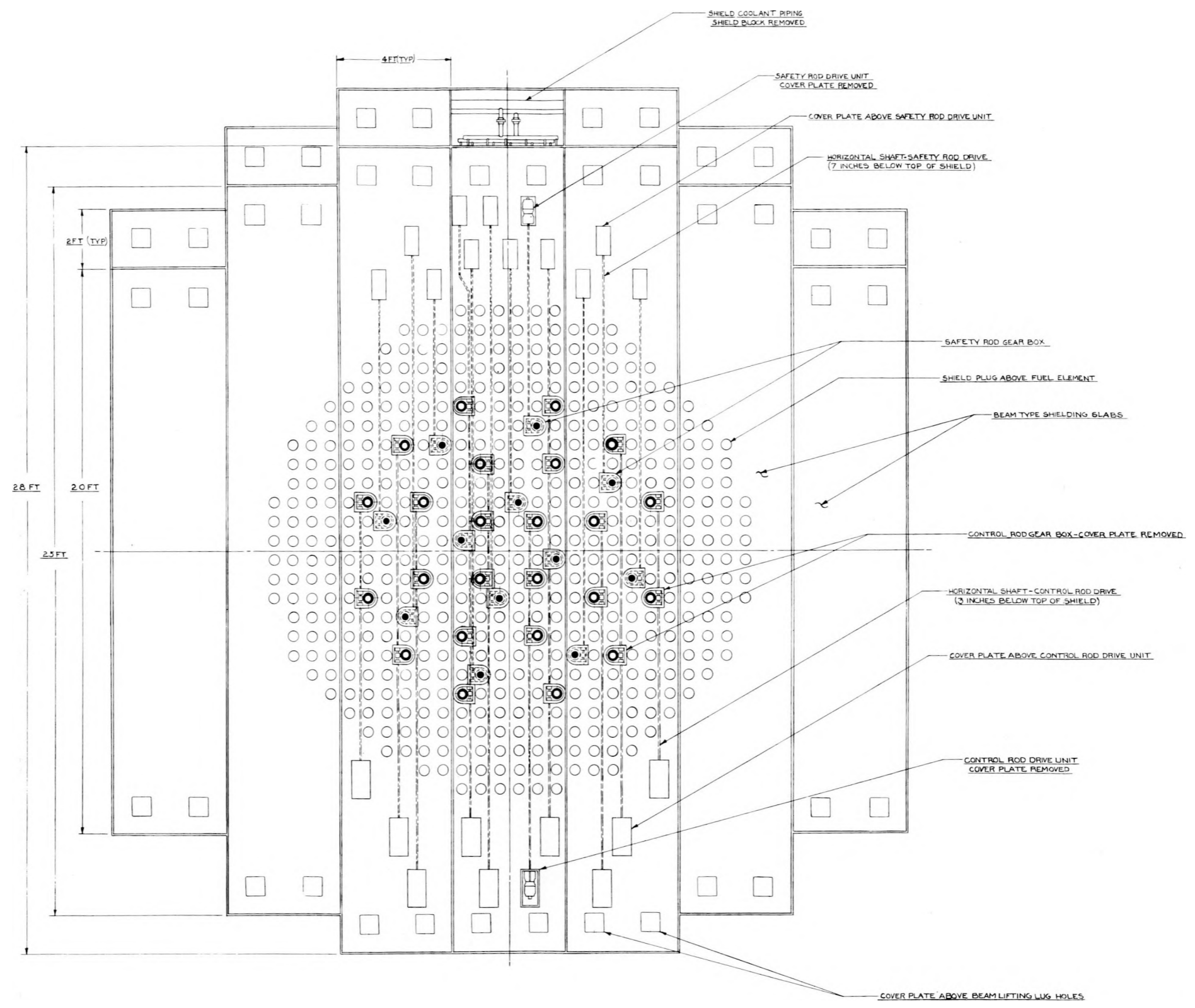

SCALE IN FEET

NORTH AMERICAN AVIATION, INC.
 ATOMIC ENERGY RESEARCH DEPARTMENT
 5000 BOULDER BLVD., CALIFORNIA

REPORT NO. NA-400-1000
 DRAWING NO. SRD-925015

SCALE: 3/4" = 1'-0"
 DATE: 11-19-53

P-17 CONTROL AND SAFETY
 ROD DRIVE SYSTEM

UNCLASSIFIED

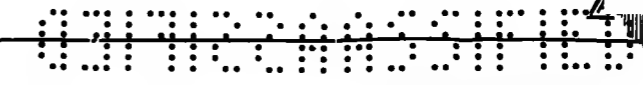
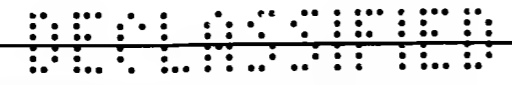
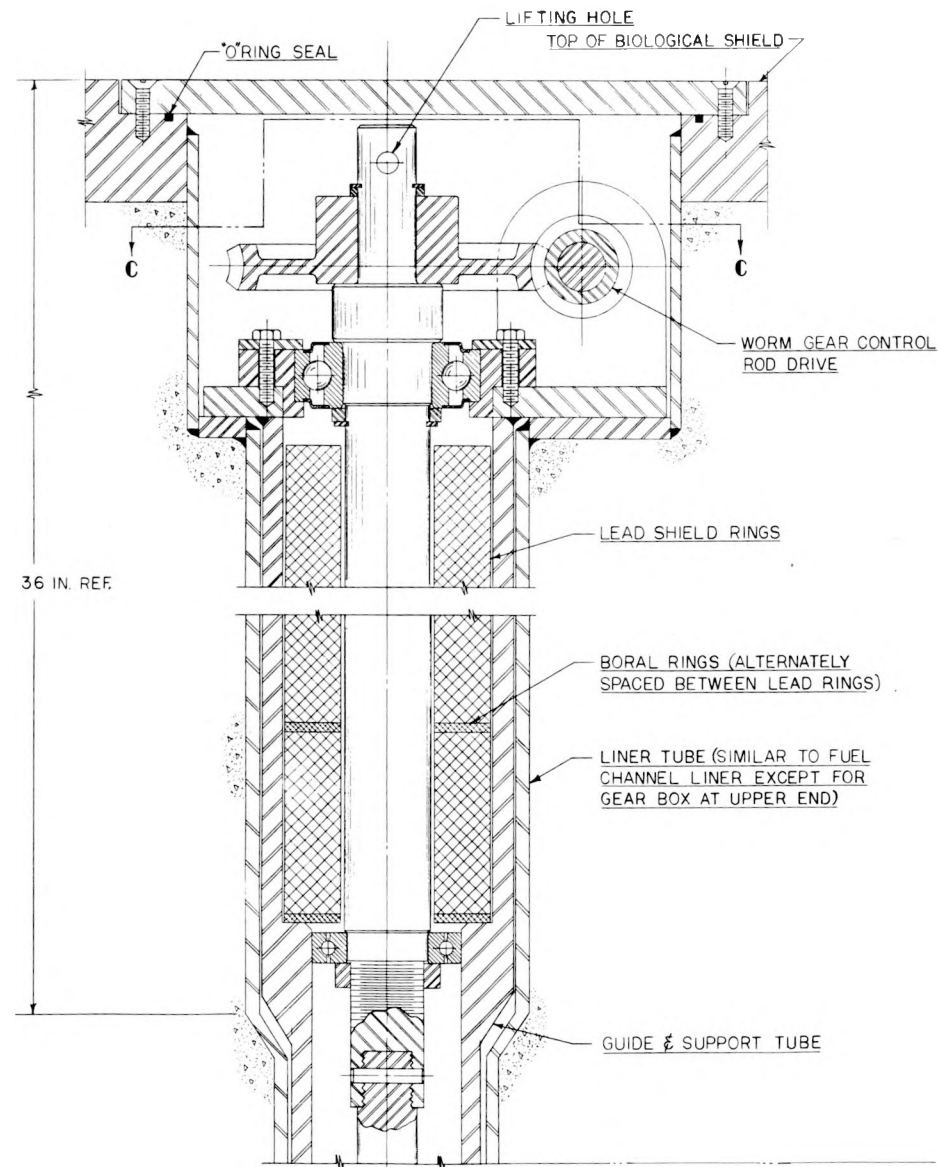
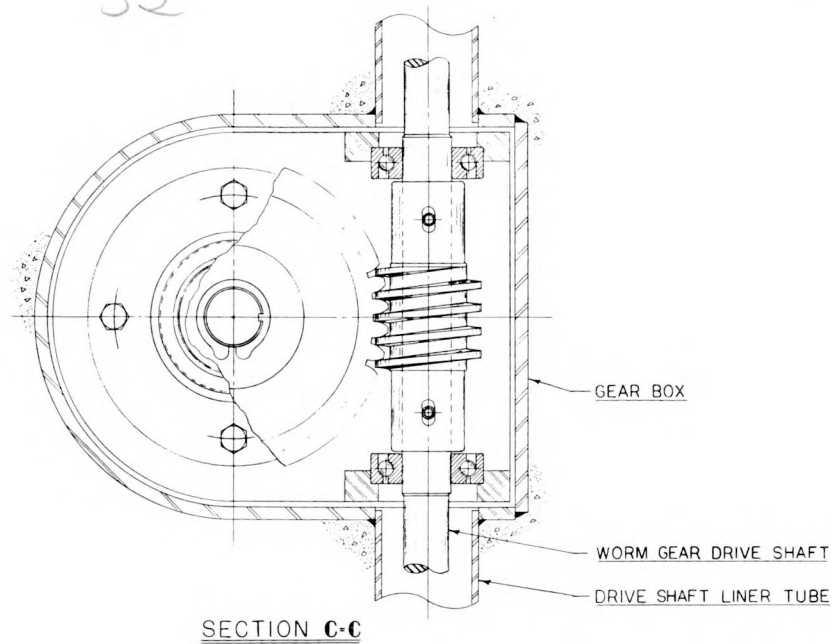

Fig. 7. Control and Safety Rod Drive System

510576-00710

32



DETAIL A

CONFIDENTIAL

33

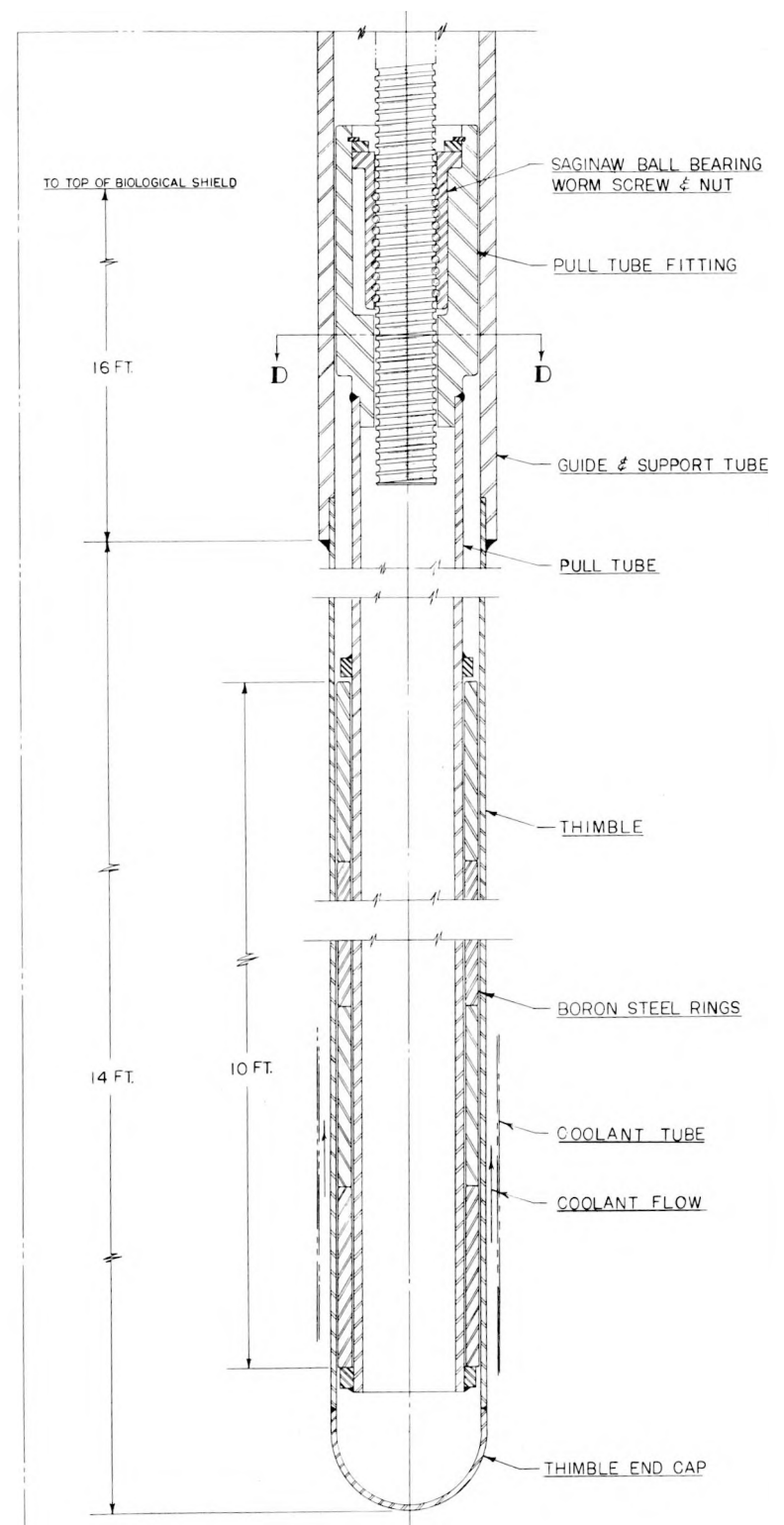

DETAIL B

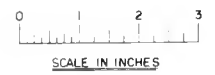
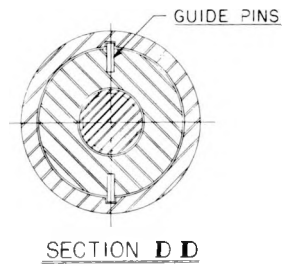

NORTH AMERICAN AVIATION, INC.
 10000 PARKWAY AVENUE
 FORT WORTH, TEXAS 76116
 P-17 CONTROL ROD SRDP-925013

Fig. 8. Control Rod

34

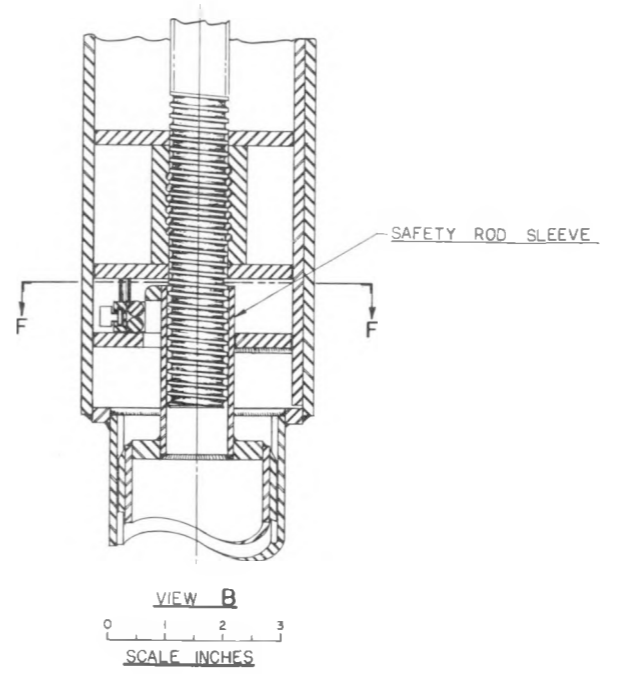
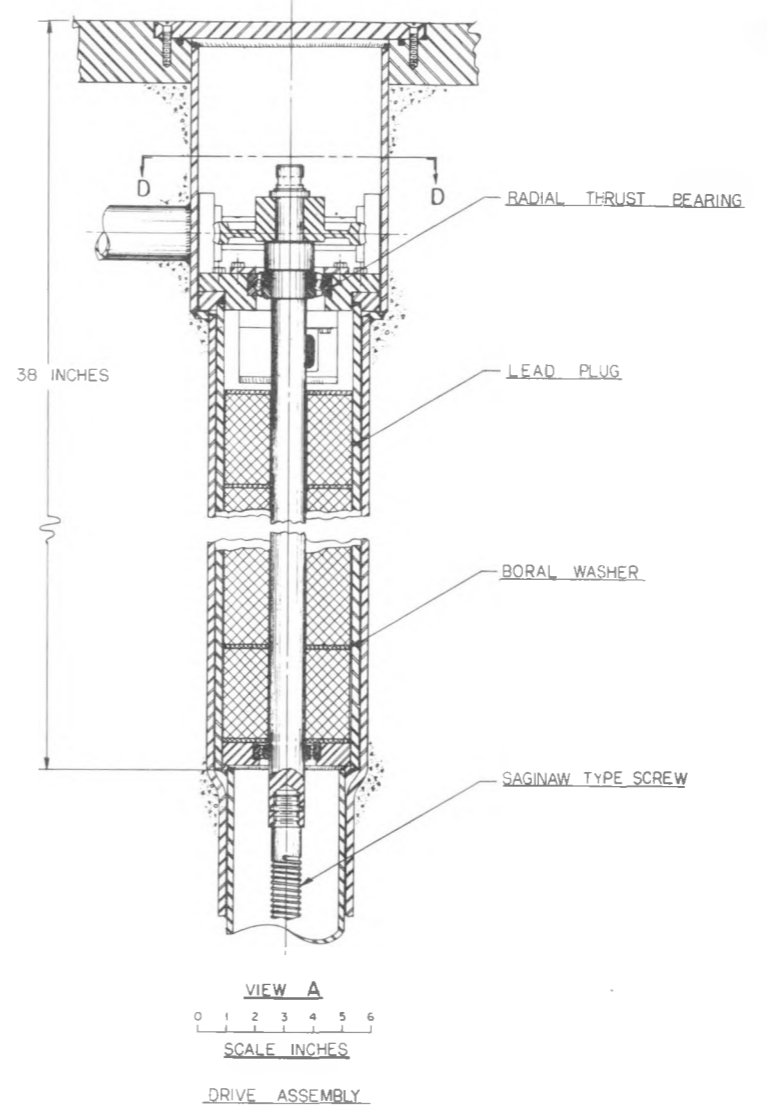
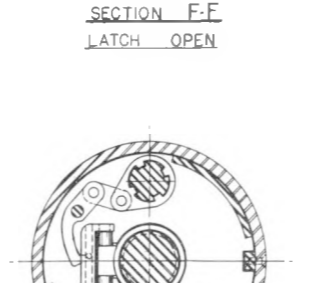
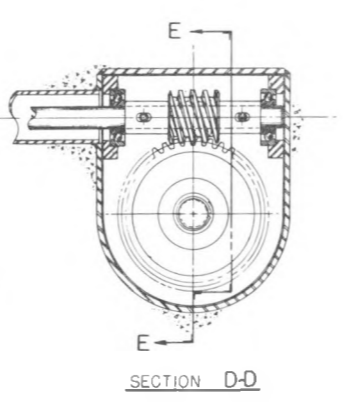
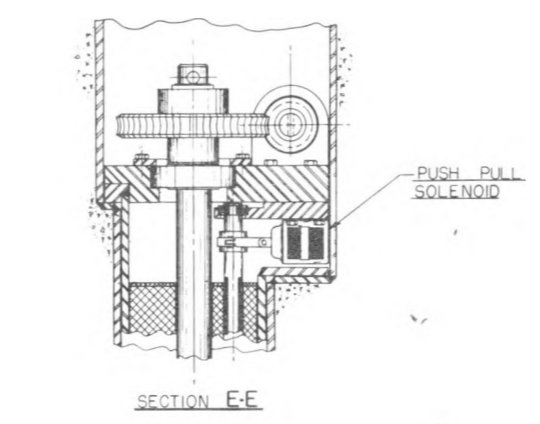
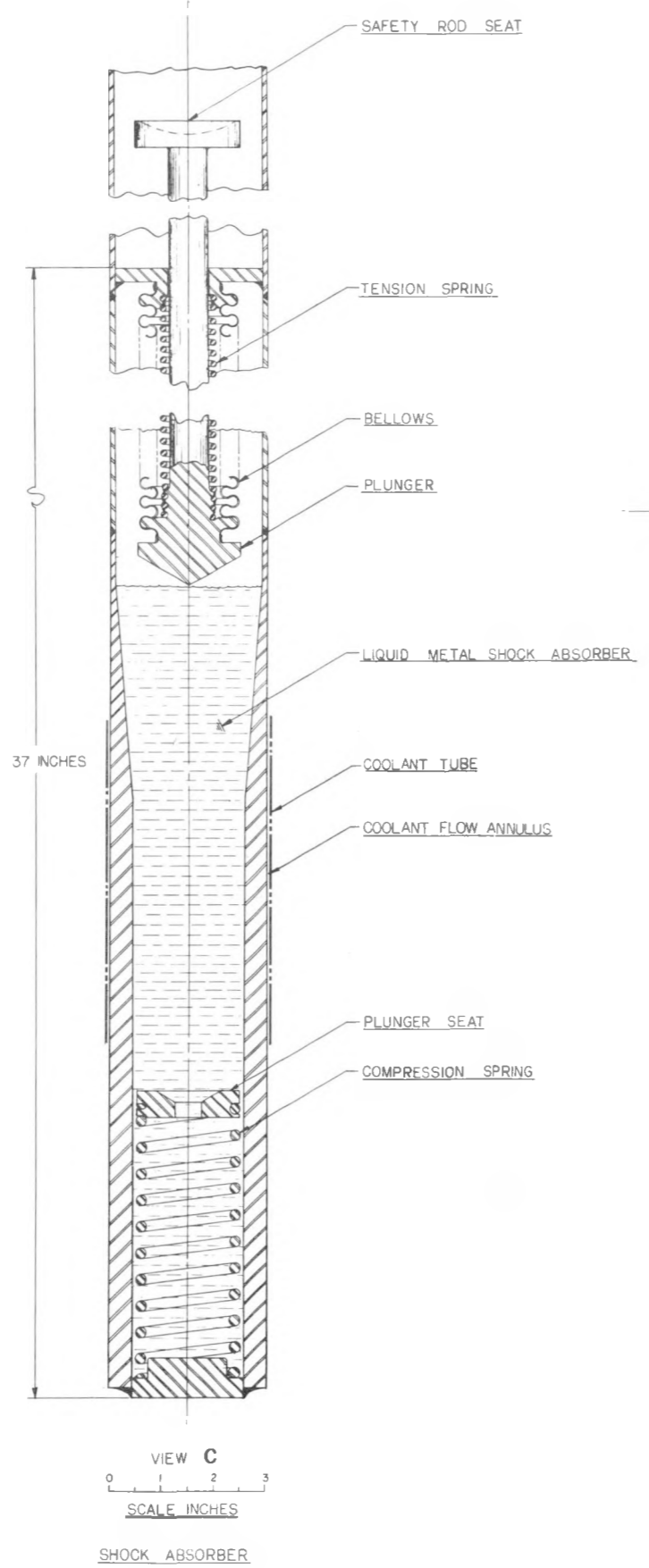

35

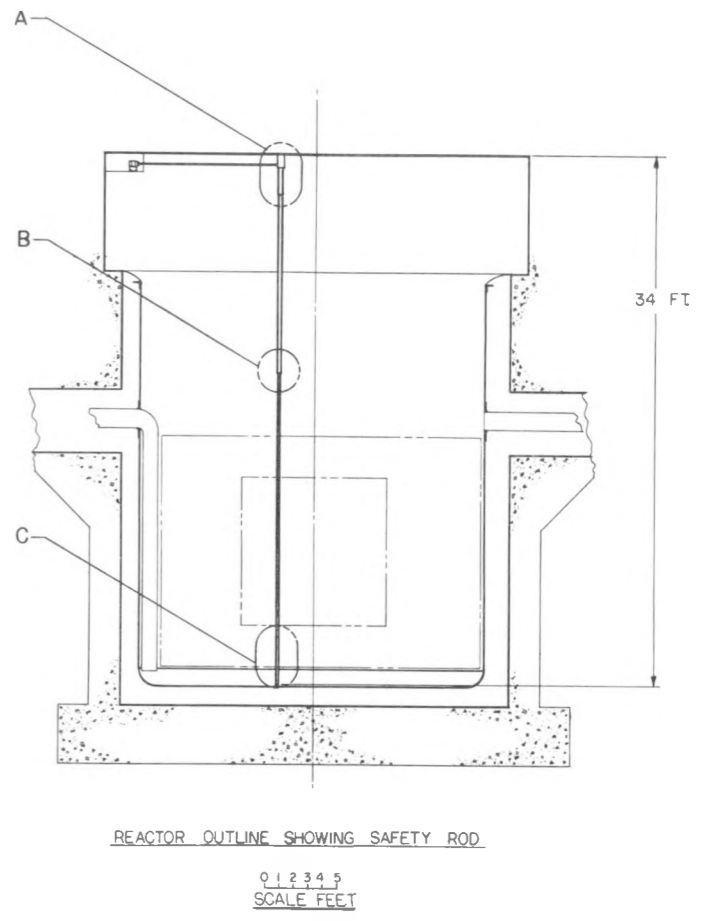

Fig. 9. Safety Rod

UNCLASSIFIED

CONFIDENTIAL

UNCLASSIFIED

36

37

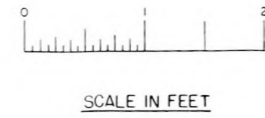
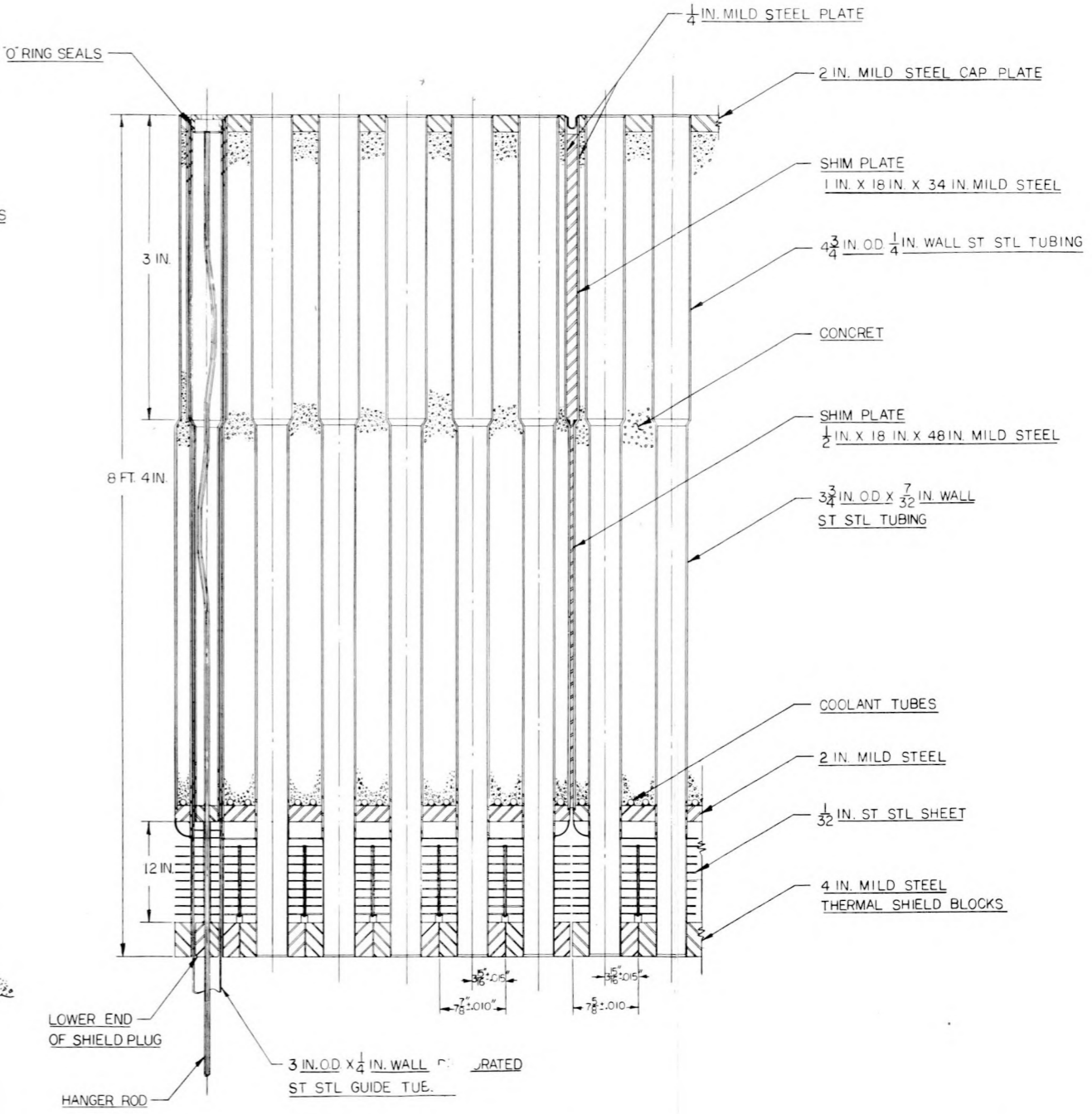
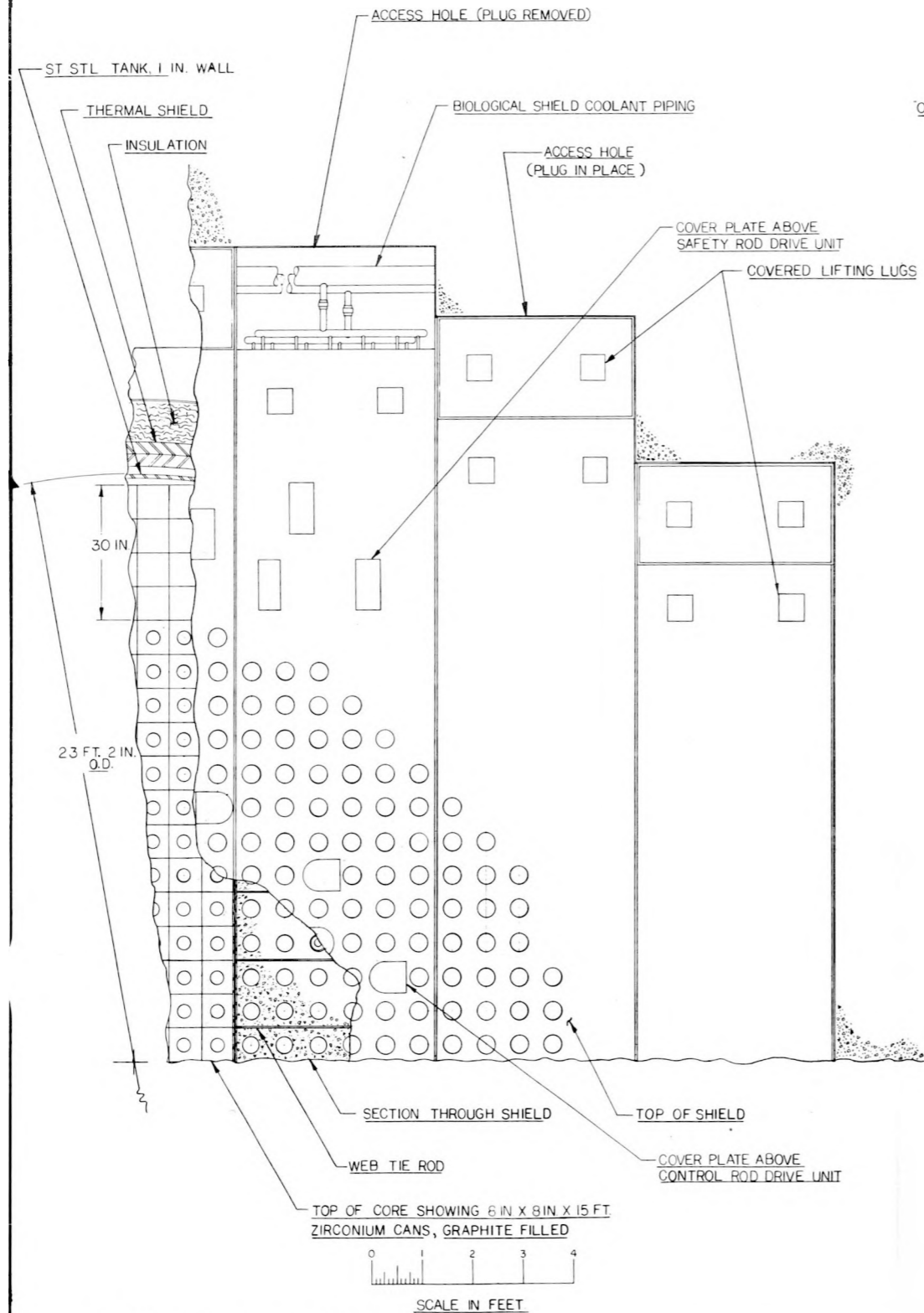

NORTH AMERICAN AVIATION INC
NUCLEAR ENERGY RESEARCH DEPARTMENT
P.O. BOX 308 CORVALLIS, OREGON

REPORT NO. WAA	MEMO	DATE: 7-20-58	FIG. NO.
SCALE: UNIFIED	DRAWN BY: WALTERS	APPROVED: [Signature]	
P-17 BEAM TYPE UPPER BIOLOGICAL SHIELD			SRDP-926016

Fig. 10. Upper Biological Shield, Beam Type

SRDP-926016

CONFIDENTIAL

CONFIDENTIAL

38

~~CONFIDENTIAL~~

39

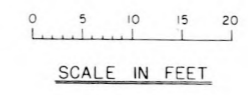
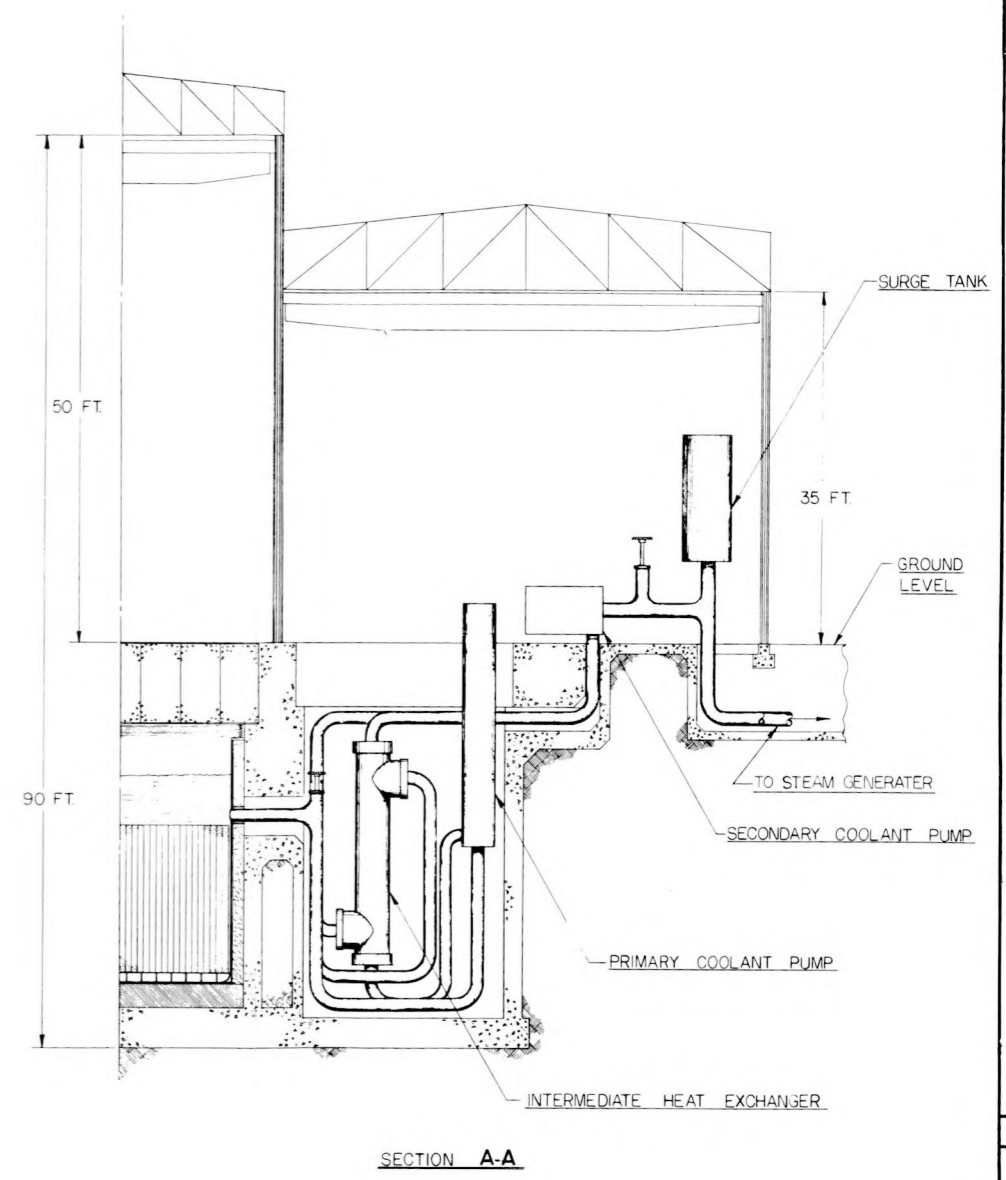
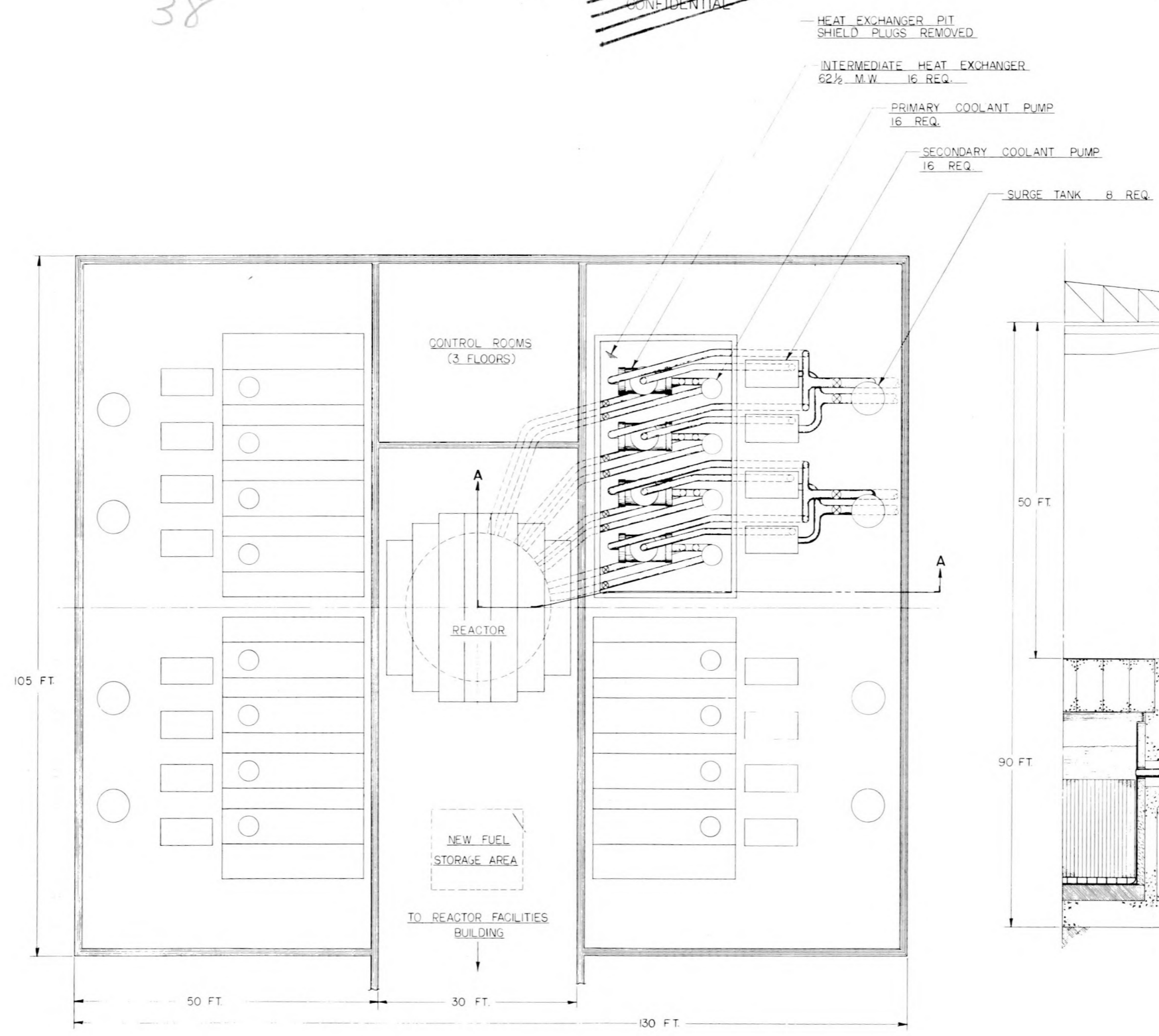

~~CONFIDENTIAL~~

NORTH AMERICAN AVIATION, INC.			
ATOMIC ENERGY RESEARCH DEPT.			
2550 COLLEGE AVE. BERKELEY, CALIF.			
REPORT NO. NAA-50	PAGE NO.	DATE	APPROVED BY
SCALE: NOTED	DESIGN BY: <i>[Signature]</i>	DATE: 9-23-58	APPROVED: <i>[Signature]</i>
P-17 BUILDING ARRANGEMENT			SRDP-932011

Fig. 11. Building Arrangement

SRDP-932011

DECLASSIFIED

DECLASSIFIED



48

REFERENCES

1. Weisner, E. F., "Thorium Uranium-233 Power Breeder Reactor," NAA-SR-266, January 1, 1954.
2. Balent, R., W. C. Cooley, R. L. Stoker, "Thorium-Uranium Converter Reactor Design Study," NAA-SR-207, April 15, 1953.