

**COMPUTER PROGRAMS FOR DESCRIBING  
THE DYNAMIC BEHAVIOR OF EBR-II**

by

**H. A. Larson, I. A. Engen, M. R. Tuck, and R. W. Hyndman**

**EBR-II Project  
Argonne National Laboratory  
Argonne, Illinois - Idaho Falls, Idaho**

**September 1973**

**NOTICE**  
This report was prepared as an account of work sponsored by the United States Government. Neither the United States nor the United States Atomic Energy Commission, nor any of their employees, nor any of their contractors, subcontractors, or their employees, makes any warranty, express or implied, or assumes any legal liability or responsibility for the accuracy, completeness or usefulness of any information, apparatus, product or process disclosed, or represents that its use would not infringe privately owned rights.

TABLE OF CONTENTS

	<u>Page</u>
ABSTRACT . . . . .	7
I. INTRODUCTION . . . . .	7
II. DESCRIPTION OF COMPUTER AND METHOD OF DATA COLLECTION. . .	9
III. DYNAMICS PROGRAMS FOR ROD-DROP EXPERIMENTS. . . . .	11
A. Mathematical Discussion of Inverse Kinetics and of Feedback-reactivity-fitting Procedures . . . . .	11
B. Description of Codes . . . . .	14
1. Rod-drop Calibration Code (RCL). . . . .	16
2. Feedback-reactivity Calculation Code (FBCK). . . . .	17
3. Power and Feedback-reactivity Plotting Code (RPL). . . . .	21
4. Feedback-reactivity Modeling Code (MODEL F) . . . . .	24
IV. DYNAMICS PROGRAMS FOR ROD-OSCILLATOR EXPERIMENTS . . . . .	25
APPENDIXES	
A. Mathematical Analysis for Inverse-kinetics Calculations . . . . .	31
B. Mathematical Analysis of Rod-drop Curve Fit. . . . .	35
C. Code Listing of Programs . . . . .	37
REFERENCES . . . . .	89

LIST OF FIGURES

<u>No.</u>	<u>Title</u>	<u>Page</u>
1.	EBR-II Data Collection with DAS . . . . .	10
2.	Sequence and Inputs for Codes for Processing Data from Rod-drop Experiments. . . . .	15
3.	Example of Drop-rod Calibration Curve (Run 49C, 500 kWt).	18
4.	Example of Output of RPL Code (Start of Run 49C, 58 MWt).	23
5.	Example of Feedback Data Points and Fitted Curve (Run 49C, 58 MWt). . . . .	26
6.	Flowchart Describing Operation of ROSCIL (Rod-oscillator) Program . . . . .	28

COMPUTER PROGRAMS FOR DESCRIBING  
THE DYNAMIC BEHAVIOR OF EBR-II

by

H. A. Larson, I. A. Engen, M. R. Tuck, and R. W. Hyndman

ABSTRACT

Kinetic studies are performed at EBR-II to ensure that the dynamic characteristics of the reactor indicate integrity of the system and surrounding environment. These studies are done by analysis of power perturbations caused by a drop rod and a rod oscillator. The power perturbation following a rod drop is first analyzed by inverse-kinetics procedures to obtain a time-dependent reactivity. This reactivity is further fitted to a feedback transfer function characteristic of linear differential equations. The power perturbation caused by the oscillator is Fourier-analyzed to obtain a series of Fourier coefficients representing the reactor transfer function directly. The feedback transfer function is then obtained from this and the zero-power transfer function.

I. INTRODUCTION

Kinetic studies are performed on nuclear reactors to ensure that the dynamic characteristics indicate integrity of the system and surrounding environment in the event of an undesired power perturbation. These kinetic studies may be done using either an analytical approach with computer programs that simulate the dynamic behavior of the reactor or an experimental approach performed directly on the reactor. The former approach makes use of various types of time-dependent diffusion-theory and/or transport-theory computer codes together with an intimate knowledge of the core structure and materials. The latter approach may use either noise analysis of data or one of several types of perturbations of the reactor with subsequent mathematical analysis.

The experimental procedures lend themselves easily to the determination of the reactor transfer function. This function, defined as the ratio of the Laplace transform of the output function to the Laplace transform of the input function, is determined for the purpose of studying dynamic behavior of the reactor. Essentially, the transfer function provides an evaluation of the frequency-dependent reactivity-feedback function. It describes the characteristic behavior of the system, and by doing so, allows development of a mathematical model that can be used to determine stability of the reactor system, verify predicted physical behavior of the system, and determine the control-system characteristics necessary for automatic control.

Studies of the dynamic behavior and system stability of Experimental Breeder Reactor No. 2 (EBR-II) have been performed for several years. Several publications<sup>1-6</sup> that document and discuss the behavior of the reactor are based on a series of computer programs for analysis of data.

In the past, data were reduced and analyzed using IBM systems 1620 and 360/75 for various stages of data analysis.<sup>3</sup> Now, a digital data acquisition system (DAS)<sup>7</sup> based on a Xerox Data Systems Sigma-5 computer is used on-line with EBR-II.<sup>8</sup> It serves as an operational aid, a data-reporting tool, and an analysis device. This report will be descriptive of the computer programs used on the DAS only.

Rod-drop experiments are generally performed for each EBR-II run. The reactor is brought to the desired steady-state power level, and then reactivity is removed from the core by ejecting the drop rod. The resulting power trace is analyzed. Feedback reactivity, a dynamic characteristic of the core, is determined through an inverse-kinetics procedure applied to rod-drop power traces both at the desired power level and at a 500-kWt reference level where feedback is negligible. The point-by-point difference of these traces determines the feedback reactivity.

A mathematical model has been developed to interpret feedback effects.<sup>3</sup> The computational procedure involves separation of measured feedback reactivity into individual time-dependent components by empirically fitting transfer-function-calculated data to the measured data; a series of trial-and-error iterations forces the assumed frequency-dependent transfer function to fit the measured data.

Rod-oscillator experiments have been performed for selected runs. Data reduction is performed as described in Ref. 2, except that for present

operations with the Sigma-5 DAS system the calculations are performed on-line.

Experience thus far shows that the package of programs described herein for the Sigma-5 DAS computer system allows a significant savings in time when compared with the previous system.<sup>3,5</sup> This is due primarily to the fact that data are recorded directly into the computer core for immediate execution. Furthermore, since only one computer system is used, the package of programs used may be executed contiguously.

## II. DESCRIPTION OF COMPUTER AND METHOD OF DATA COLLECTION

The EBR-II digital data acquisition system (DAS) consists of a Xerox Data Systems (XDS) Sigma-5 digital-computer system with an associated analog-to-digital (A/D) front end and peripheral equipment. For simplicity, the system may be considered to consist of three major groups: (1) the A/D front end, (2) the Sigma-5 computer, and (3) peripheral input/output (I/O) equipment.

The reactor-parameter-sampling hardware consists of 522 analog input channels, which are routed through a large digital patch panel to permit flexibility in switching analog input signals. These signals are then routed to their respective multiplexers.

Figure 1 shows the data-collection process in block-diagram form. The XDS multiplexers transform raw data to an analog signal in the range  $\pm 10$  V, which is transmitted to a controller/digitizer. Converted to 16-bit digital output, 1 bit of which is used for parity, the output is presented to an analog input controller, which controls the signal sampling and core storage of digitized data. The signal sampling rate is controlled by a frequency-control unit, a subsystem of the analog input controller.

The signals, when digitized, are put directly into the core. The central processing unit (CPU) contains 32 k ( $k = 1024$ ) words of magnetic core memory interfaced with a semi-independent external multiplexing input/output processor (MIOP). The CPU controls program execution, performs arithmetic and logic functions, addresses core and private memory, retrieves and stores instructions and data, controls data flow

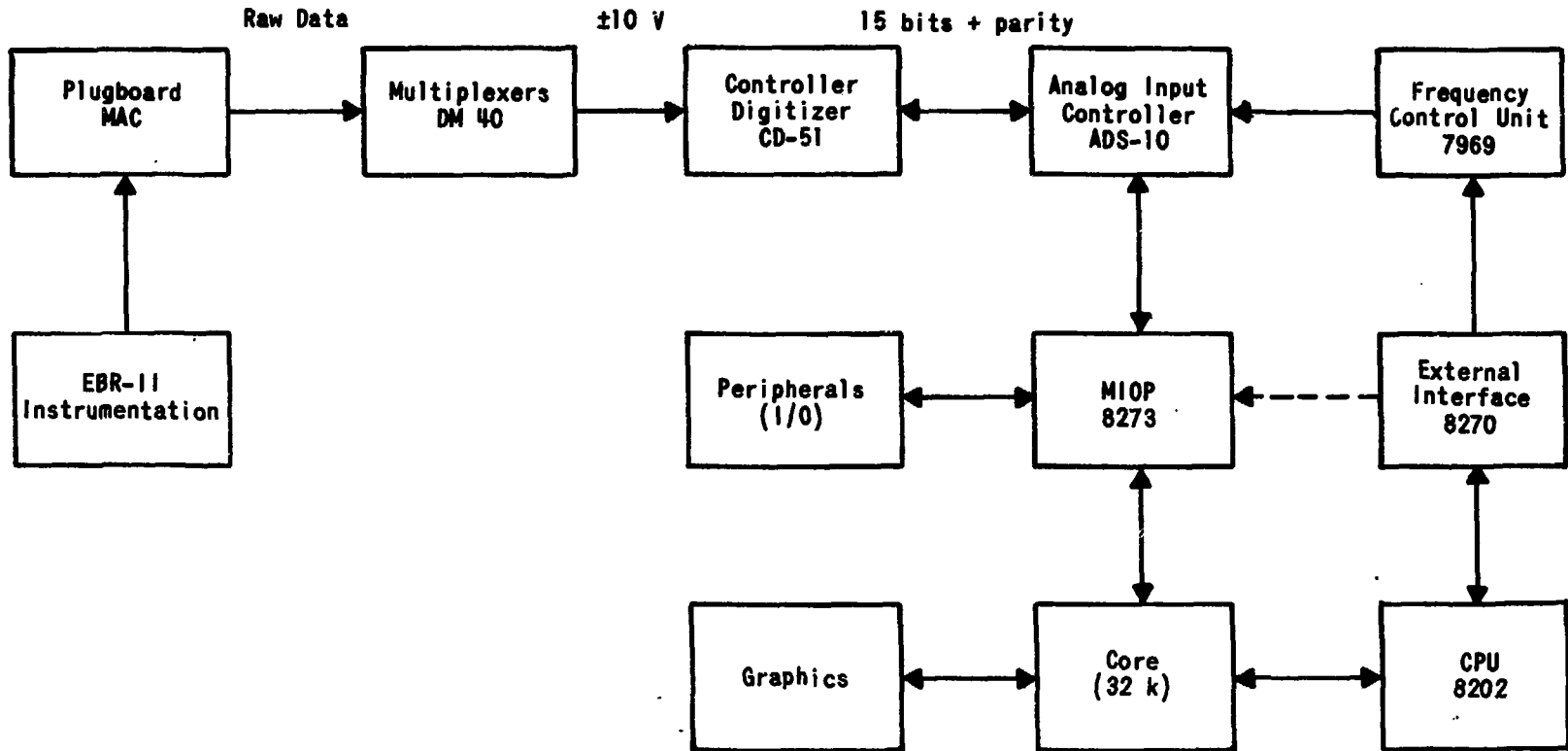

Fig. 1. EBR-II Data Collection with DAS

between core memory and other units in the system, and provides CPU timing.

Peripherals include a card reader, card punch, line printer, and Teletypewriter. Other input/output devices are three magnetic-tape drives, two high-speed disk storage units, a Calcomp plotter, and an interactive graphics display. Four alphanumeric (A/N) displays with keyboards have been implemented for reactor-operator communication; these allow the operator to request a display of data from any sensor connected to the system, automatically updated at intervals with fresh data and the time of day.

### III. DYNAMICS PROGRAMS FOR ROD-DROP EXPERIMENTS

The perturbation mechanism used in the rod-drop method at EBR-II is a stainless steel rod dropped from the reactor core and subsequent replacement of the rod volume by sodium. This results in a reactivity loss of about 0.02\$ over a period of about 120 msec. The signal from an ion chamber is processed as described in the previous section and fed directly into core memory for mathematical processing.<sup>5,6,8</sup>

#### A. Mathematical Discussion of Inverse Kinetics and of Feedback-reactivity-fitting Procedures

About 40 sec of digitized data are analyzed by an inverse-kinetics code using 5-msec time steps. The inverse-kinetics equations, after reduction, are:<sup>3,9</sup>

$$k_{ex}(t+h) = \frac{1}{1 - \beta(1 - \frac{h}{2} \sum \lambda_i a_i)}$$

$$\left\{ \frac{\beta}{2h} [n(t+2h) - n(t)] - \sum \lambda_i e^{-\lambda_i h} \left[ \beta c_i^*(t) + \frac{k_{ex}(t) + 1}{2} \beta a_i h n(t) \right] \right\} \frac{1}{n(t+h)} + 1 \quad (1)$$

and

$$c_1(t+h) = e^{-\lambda_1 h} \left\{ c_1(t) + \frac{h}{2} \frac{k_{ex}(t) + 1}{\ell^*} \beta a_1 n(t) \right\} + \frac{h}{2} \frac{k_{ex}(t+h) + 1}{\ell^*} \beta a_1 n(t+h), \quad (2)$$

where  $h$  is the time step chosen, and the other symbols are defined at the end of Sec. IV. In these equations, the time step is considered short enough to allow approximating the integral expression by a simple trapezoidal rule. Further, because the derivative of the neutron density is multiplied by the lifetime, the contribution to the reactivity by this term may be ignored. (The prompt neutron lifetime of EBR-II is of the order  $10^{-7}$  sec.) Equations (1) and (2) are derived from the kinetics equations (the system of equations describing time-dependent neutron behavior in a point kinetics sense) in Appendix A.

Before rod-drop experiments are performed, the rod is calibrated by dropping it several times with the reactor at a low power level, say 500 kWt, where feedback is insignificant. For each of these drops, the inverse-kinetics procedure is applied to the digitized power data, and the data are then arithmetically averaged. The resulting average is used as the calibration data; if feedback is neglected, the asymptotic value of the reactivity so determined can be used as a measure of the rod worth. The worth of the stainless steel drop rod now being used is on the order of 0.02\$.

To determine a time-dependent feedback reactivity, the rod is again dropped several times at the desired power level. The reactivities determined are again averaged arithmetically and then subtracted from the 500-kWt calibration data at corresponding values of time after the rod drop.

A requirement for valid rod-drop results is that the reactor be at delayed critical condition just before the drop. (Computer studies showed that for an error of 0.20  $Ih$  in the critical state of the reactor, the error in feedback reactivity is approximately 4.5%.) This requirement for delayed critical condition is satisfied by using the real-time inverse-kinetics code RAVE to make calculations based on reactor-power sampling at ten times a second. The value of the reactivity averaged over these

10 samples is shown on an alphanumeric display screen at 1-sec intervals. If the average value remains sufficiently small ( $<|0.1|I_h$ ) for 3 sec, a rod drop is allowed. Some of the data-acquisition and -reduction codes and procedures used by RAVE are peculiar to EBR-II. They are dictated by the configuration of the EBR-II system and may or may not be readily converted to other computing systems.

The data from a rod drop are acquired under control of the RDRP code,<sup>10</sup> which, beginning 0.5 sec before the drop, collects 8000 points of power data and 500 points of rod-position data at a sampling rate of 200 samples/sec. The data are stored on magnetic tape and can be operated on immediately (between samples in real-time) or retained for further off-line processing. To check experimental validity, inverse-kinetics calculations are performed on the first 500 points of power data, and the results are displayed on both the line printer and the interactive graphics of the data system. If poor data are indicated, the drop can be repeated immediately. RDRP has the same restrictions as RAVE with respect to conversion for or use with other computing systems.

The method proposed by Hyndman and Nicholson<sup>3</sup> can be used to interpret the feedback curves mathematically. A relatively simple mathematical model of the feedback function, in the complex domain, is assumed and forced to fit experimental data. This model assumes a feedback transfer function of the form

$$H(s) = \sum_{i=1}^I \frac{A_i \exp(-sT_i)}{1 + s\tau_i}, \quad (3)$$

where

$H(s)$  is the Laplace transform of the time-dependent feedback transfer function,  $h(t)$ ;

$A_i$  represents arbitrary weighting constants;

$\tau_i$  represents the time constants for the system;

$s$  is the Laplace transform variable; and

$T_i$  represents the corresponding delay constants.

Equation (3) is characteristic of linearized kinetics equations and linear feedback processes; consequently, it will not accurately represent

nonlinear processes in the reactor. Using an assumed set of initial conditions for the arbitrary constants,  $A_1$ , in Eq. (3), the convolution integral is calculated as

$$FB(t) = \int_0^t h(t - \tau)P(\tau)d\tau, \quad (4)$$

where  $P$  is relative power change from time zero, the start of the drop. The time-dependent feedback,  $FB(t)$ , is then visually compared with the feedback-reactivity curve, and the constants,  $A_1$ , are adjusted until a proper fit is attained. The numerical solution of Eq. (4) is given in Appendix B.

The time constants are generally fixed at 0.2, 0.4, 2.0, and 4.0 sec. The first two were attributed by Hyndman and Nicholson<sup>3</sup> to fuel expansion and coolant expansion. The other two represent, in part, subassembly-bowing effects and control-rod-extension effects; thus, nonlinear feedbacks are represented approximately by Eq. (3). Experience has shown that the constants,  $A_1$ , of Eq. (3) are relatively sensitive to small changes in the structure of the feedback-reactivity curve. Although many combinations of  $A_1$  may possibly fit the curve satisfactorily, it is believed that the small-time-constant terms do reflect the prompt behavior of the reactor.

## B. Description of Codes

Four codes are used to process the power and reactivity data from rod-drop experiments. They are to be used contiguously. The four codes and their purposes are:

RCL	Drop-rod calibration code
FBCK	Feedback-reactivity calculation code
RPL	Power and feedback-reactivity plotting code
MODEL	Feedback-reactivity modeling code

Figure 2 is a block diagram showing the input and output of each of these codes and the manner in which the codes relate to each other.

Following is a detailed description and enumeration of input requirements for each code.

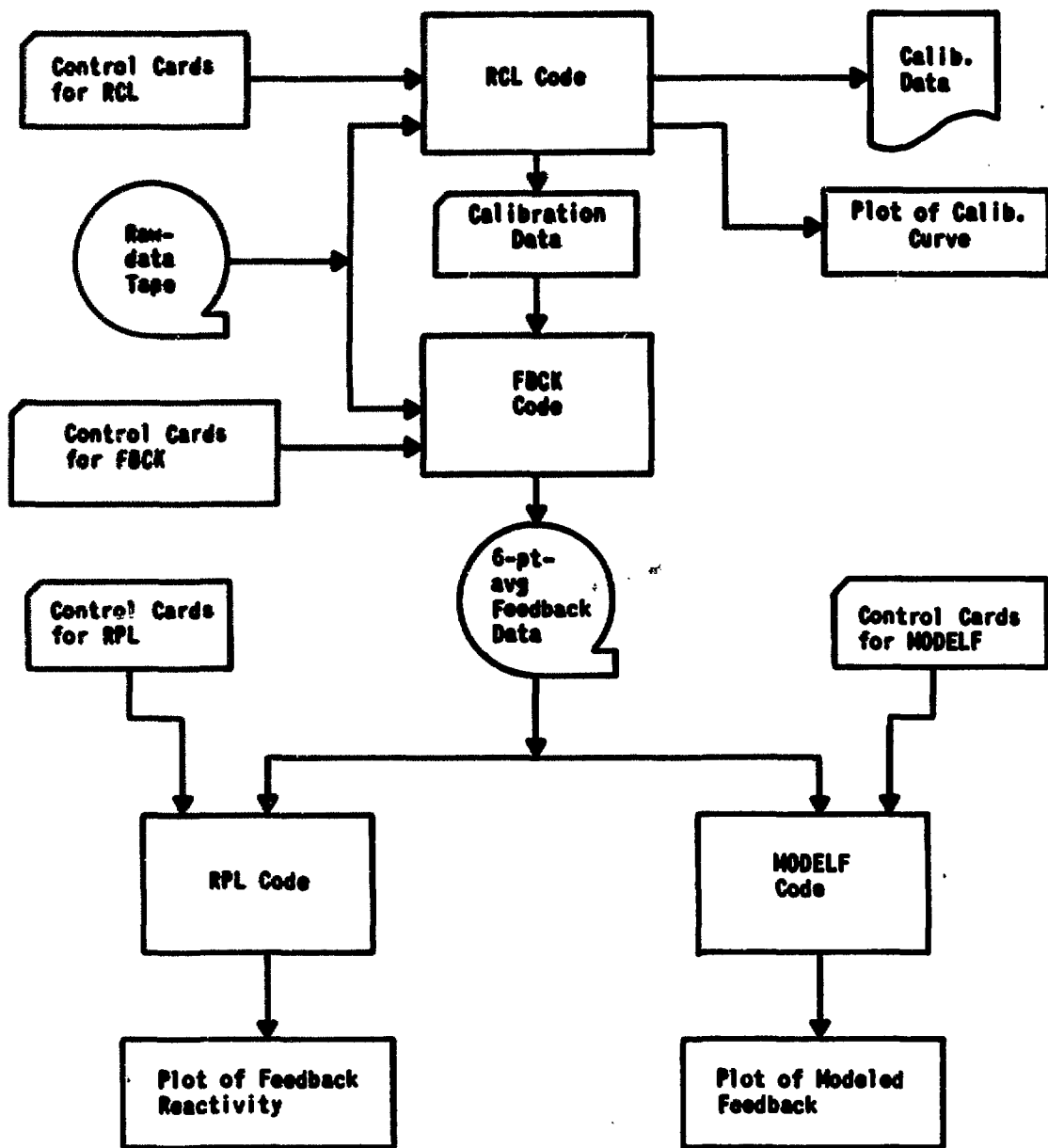

Fig. 2. Sequence and Inputs for Codes for Processing Data from Rod-drop Experiments

1. Rod-drop Calibration Code (RCL)

The RCL program is designed to produce position-dependent calibration data for the feedback-reactivity calculation code FBCK. These data are then converted to time-dependent reactivity, which is subsequently subtracted from the time-dependent reactivity at power by FBCK to produce feedback reactivity. These data also provide a reactivity calibration curve, which in turn provides the reactivity worth of the drop rod.

Data input to this code are control cards and a raw-data tape of the power trace at very low power level (say 500 kWt). Inverse-kinetics procedures convert these data to position-dependent reactivity data.

The input data are:

1 FORMAT (316)

<u>Parameter</u>	<u>Value</u>
NPC	Number of rod drops to be processed
NWCS	Number of position steps desired in calibration
IRBETA	<0: Read new normalized delayed-neutron fractions and corresponding decay constants >0: Built-in parameters are to be used

1' FORMAT (6E12.5)

Omit this card if IRBETA  $\geq$  0.

A(1)	Normalized beta fraction, $\beta_1/\beta$
A(2)	Normalized beta fraction, $\beta_2/\beta$
.	.
.	.
.	.
A(6)	Normalized beta fraction, $\beta_6/\beta$

1'' FORMAT (6E12.5)

Omit this card if IRBETA  $\geq$  0.

DC(1)	Decay constant for A(1), $\lambda_1$
DC(2)	Decay constant for A(2), $\lambda_2$
.	.
.	.
.	.
DC(6)	Decay constant for A(6), $\lambda_6$

2 FORMAT [4(4X,A4), 4E12.5]

Parameters: Reactor run number, rod-drop number, reactor power level, coolant flow (for identification)

OSV	} Normalizing factors for power data
GAIN	
DT	Time step between sample points
WCON	Calibration multiplier (usually 1.0)

3 Binary Tape

Contains alternating power and rod-position data records (non-normalized); at least 500 data points in each record.

Output from this code is a set of punched cards describing rod worth as a function of position in format 6E12.5. These cards are used as an input deck for FBCK. Output on the line printer consists of a listing of rod position and the worths obtained from each rod drop, along with the point-wise average of all drops processed. Further output of RCL is a Calcomp plot of the worth of the drop rod as a function of position during rod motion. Figure 3 is an example of this plot.

2. Feedback-reactivity Calculation Code (FBCK)

This code provides reactivity data for the drop tests at low power levels, where feedback may be ignored, and feedback reactivity at higher power levels. Data input to this code is the raw-data tape of digitized data and the card calibration data obtained from RCL.

The raw taped data are normalized by two methods, one each for the rod-position data and the reactor-power data. Overall drop-rod motion

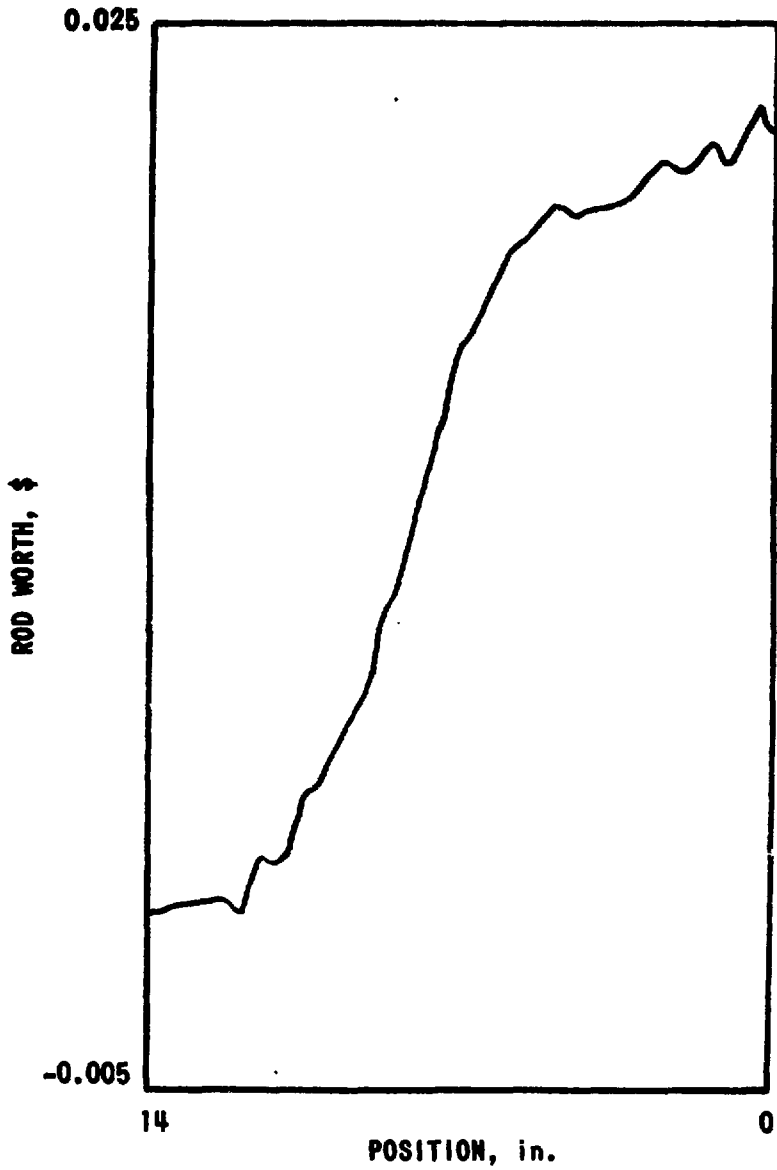

Fig. 3. Example of Drop-rod Calibration Curve (Run 49C, 500 kWt)



A(1)	Normalized beta fraction, $\beta_1/\beta$
A(2)	Normalized beta fraction, $\beta_2/\beta$
.	.
.	.
.	.
A(6)	Normalized beta fraction, $\beta_6/\beta$

Card No. 3'' FORMAT (6E12.5)

Omit this card if NOBETA > 0.

DC(1)	Decay constant for A(1), $\lambda_1$
DC(2)	Decay constant for A(2), $\lambda_2$
.	.
.	.
.	.
DC(6)	Decay constant for A(6), $\lambda_6$

Card No. 4 FORMAT (6E12.5)

ALIF	Prompt neutron lifetime (approximately $10^{-7}$ sec)
BETA	Total delayed-neutron fraction (approximately 0.0071)
CONW	Rod-calibration multiplier (usually 1.0); CONW = 0.0 produces excess reactivity instead of reactivity feedback as output
DT	Time step between power data points
RMOV	Minimum normalized drop-rod position to initiate feedback computation (0.999)

Cards No. 5-13 FORMAT (6E12.5)

WC <sub>i</sub> i=2,...,41	Calibration data, 6 points per card and usually 40 points (WC <sub>1</sub> = 0.0)
----------------------------	--

Card No. 14 (14 + NP - 1) FORMAT (2E12.5, I6)

OSV	Offset voltage	} power normalizing parameters
GAIN	Gain	
ID	Drop identification; if ID < 0, data for drop will not be processed	

Output from this code on the line printer consists of (1) a listing of the input parameters and parameters used in the computation (i.e., problem identification, delayed-neutron constants, time step, normalizing constants, rod-drop identification, drop-rod calibration, and 200 points of drop-rod position with the index of the point at which rod motion was 0.1% of total motion) and (2) a listing of integrated reactivity, reactivity feedback, and change in power, along with lists of the ratio of reactivity to integrated power change and of integrated reactivity to integrated power change.

An option allows printout of all normalized power points and reactivity-feedback points without averaging. Final line-printer listings are of the six-point-averaged feedback for each rod drop. After all drops have been processed, a listing of average power and average feedback reactivity is produced on the line printer.

Further output on magnetic tape is an array of six-point-averaged feedback and power data for plotting (by RPL code) and curve fitting (by MODEL F code).

3. Power and Feedback-reactivity Plotting Code (RPL)

This code accepts the tape of the six-point-averaged power and feedback-reactivity data from FBCK and produces a Calcomp plot. The plotter produces an individual plot of each rod-drop input and a plot of the average.

The control-card inputs to this code are:

Card No. 1 FORMAT (4I6)

NG	Number of grids to be drawn (one for each drop + one for average)
----	---



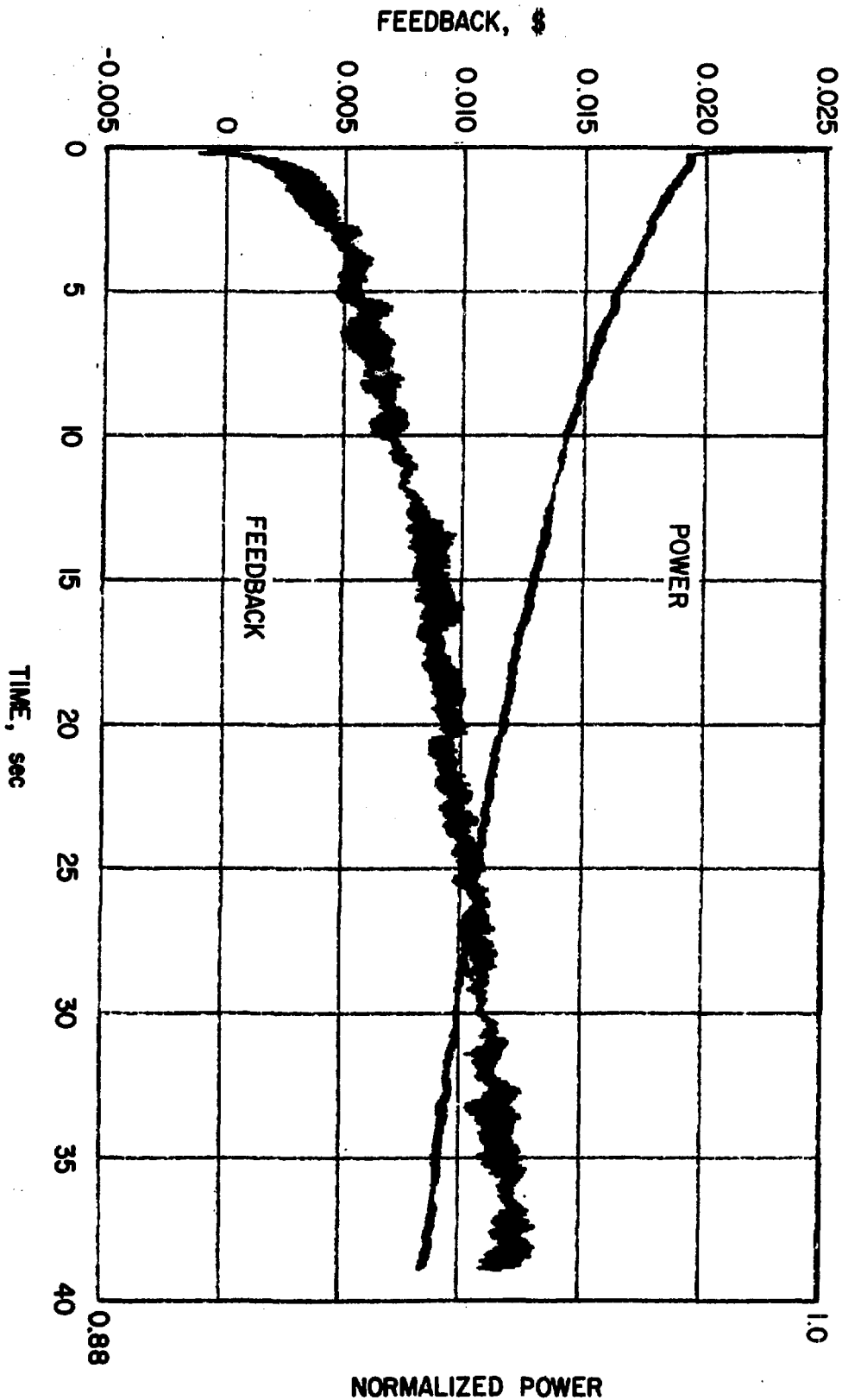

Fig. 4. Example of Output of RPL Code (Start of Run 49C, 58 MWt)

#### 4. Feedback-reactivity Modeling Code (MODEL F)

This code accepts the tape of the six-point-averaged power and feedback-reactivity data from FBCK and performs the convolution integral [Eq. (4)] using parameters of Eq. (3) input by the user. Output of the code is a plot of the feedback reactivity with the fitted curve superimposed upon the measured data. Rerunning of the code with altered parameters permits the user to obtain the "best" fit to the measured data.

The control-card input to the code is as follows:

##### Card No. 1 FORMAT (I6, 5E12.5)

N            Number of data points  
DT          Time step between points

##### Card No. 2 FORMAT (10F8.0) (plot scaling parameters)

XMIN        Minimum value, x axis  
XMAX        Maximum value, x axis  
XL          Length, x axis (in.)  
XD          Increment for cross-hatching grid  
YMIN        Minimum value, y axis  
YMAX        Maximum value, y axis  
YL          Length, y axis (in.)  
YD          Increment for cross-hatching grid

##### Card No. 3 FORMAT (10F8.0)

T1          Time delay of first model term  
T2          Time delay of second model term  
T3          Time delay of third model term  
FBPL        <0: Draw plot grid and compute scale factors, then  
            plot tape input values (measured feedback)  
            >0: Input normalized power, compute and plot model  
FMUL        Multiplies values prior to plotting (for linear  
            extrapolation to other power levels)

Card No. 4 FORMAT (I6)

NTC            Number of terms in model (<7)

Card No. 5 FORMAT (10F8.0)

A<sub>1</sub>            Weighting constant of first term  
A<sub>2</sub>            Weighting constant of second term  
·              ·              ·              ·              ·  
·              ·              ·              ·              ·  
·              ·              ·              ·              ·  
A<sub>NTC</sub>          Weighting constant of NTC term

Card No. 6 FORMAT (10F8.0)

RD<sub>1</sub>          Time constant of first term  
RD<sub>2</sub>          Time constant of second term  
·              ·              ·              ·              ·  
·              ·              ·              ·              ·  
·              ·              ·              ·              ·  
RD<sub>NTC</sub>        Time constant of NTC term

Figure 5 is an example of a fitted curve.

IV.    DYNAMICS PROGRAMS FOR ROD-OSCILLATOR EXPERIMENTS

The purpose of the rod-oscillator program (ROSCIL) now in use at EBR-II is to determine the transfer function of the reactor at a desired power level while the power is oscillated sinusoidally over a frequency range of approximately 0.005 to 8 Hz. The inputs required for the Fourier analysis used to determine the points of the transfer function are sine and cosine signals plus the ion-chamber current. There are two portions to the program: (1) gain calibration of the input channels, and (2) calculation of the transfer function.

Calibration is accomplished by injecting constant voltages into the system and averaging the values of digitized output for each channel. The average values are then divided by known input to determine the channel

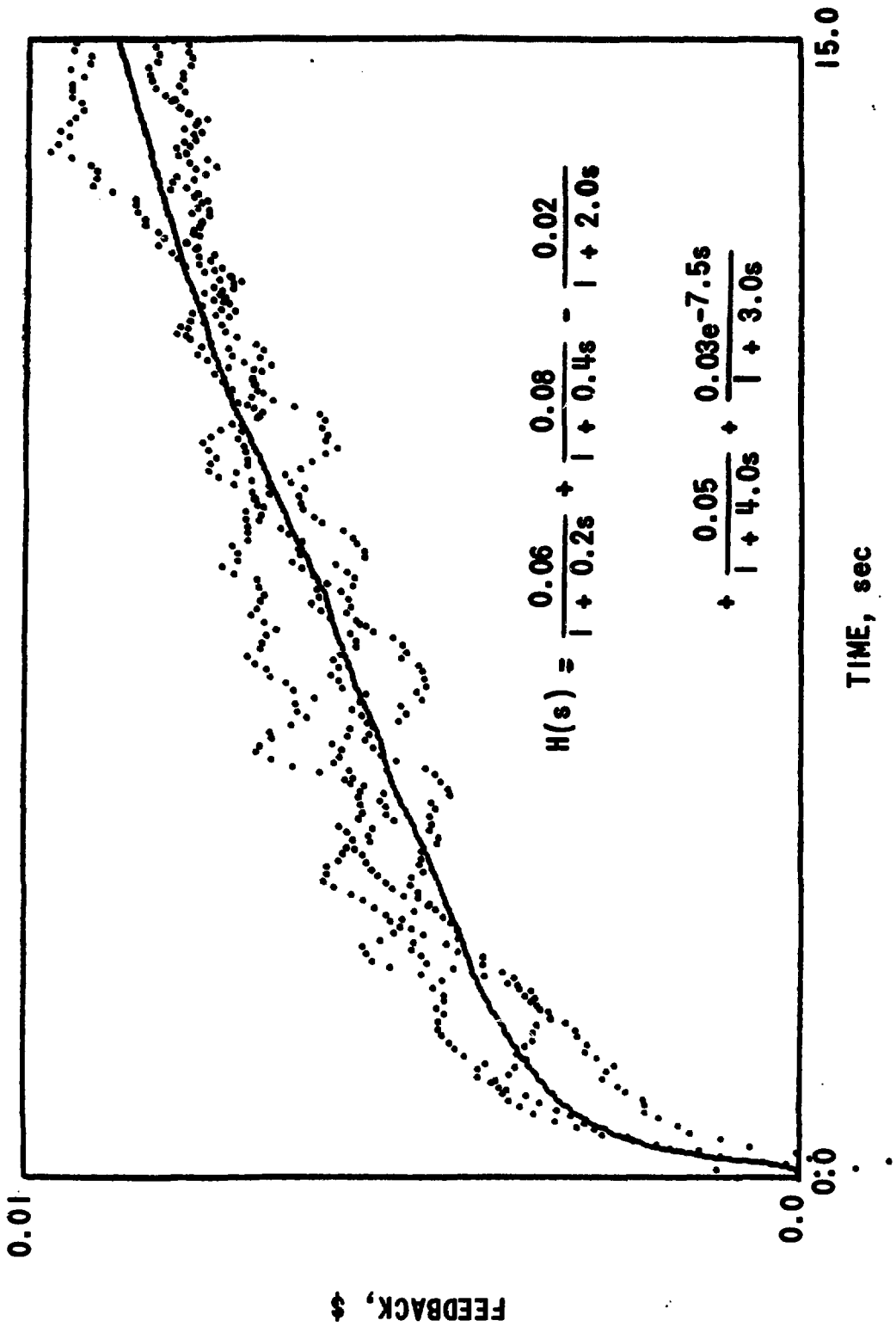

Fig. 5. Example of Feedback Data Points and Fitted Curve (Run 49C, 58 MWt)

gain. These values are used in the transfer-function calculation to normalize the gain found in the real and imaginary parts of the transfer function.

The transfer function is then calculated, first at a frequency where feedback is assumed to be negligible so corrections for gain and phase may be determined, and then at all frequencies necessary to give a representative picture of the transfer function. The zero-power transfer function is calculated at each frequency, and this value is used in conjunction with the calculated transfer-function value to determine the feedback.

To run the program, a magnetic tape must be mounted on unit 2 of the Sigma-5, and the rod-oscillator program must be loaded. All input is entered through an alphanumeric scope, and all output is written on magnetic tape and printed on the line printer.

The portions of the program are flow-charted in Fig. 6. The necessary parameters are as follows:

AA	Known input voltage, channel 1
$a_i$	Normalized beta fraction of type $i$ ( $= \beta_i/\beta$ )
BB	Known input voltage, channel 2
CC	Known input voltage, channel 3
CS	Samples per second
$c_i$	Delayed neutron precursors of type $i$
E0	Voltage proportional to reactor power
$\Delta E0_i$	Varying component (approximately average value of E0)
I	Imaginary component
j	$\sqrt{-1}$
KK1	Gain normalization factor
KK2	Phase normalization factor
$k_{ex}$	Excess reactivity
$\ell^*$	Effective neutron lifetime
M	(Number of cycles desired for integration) x 2
N	Number of sample points
n	Normalized power level
R	Real component
s	$j 2\pi f$
t	Time in sec

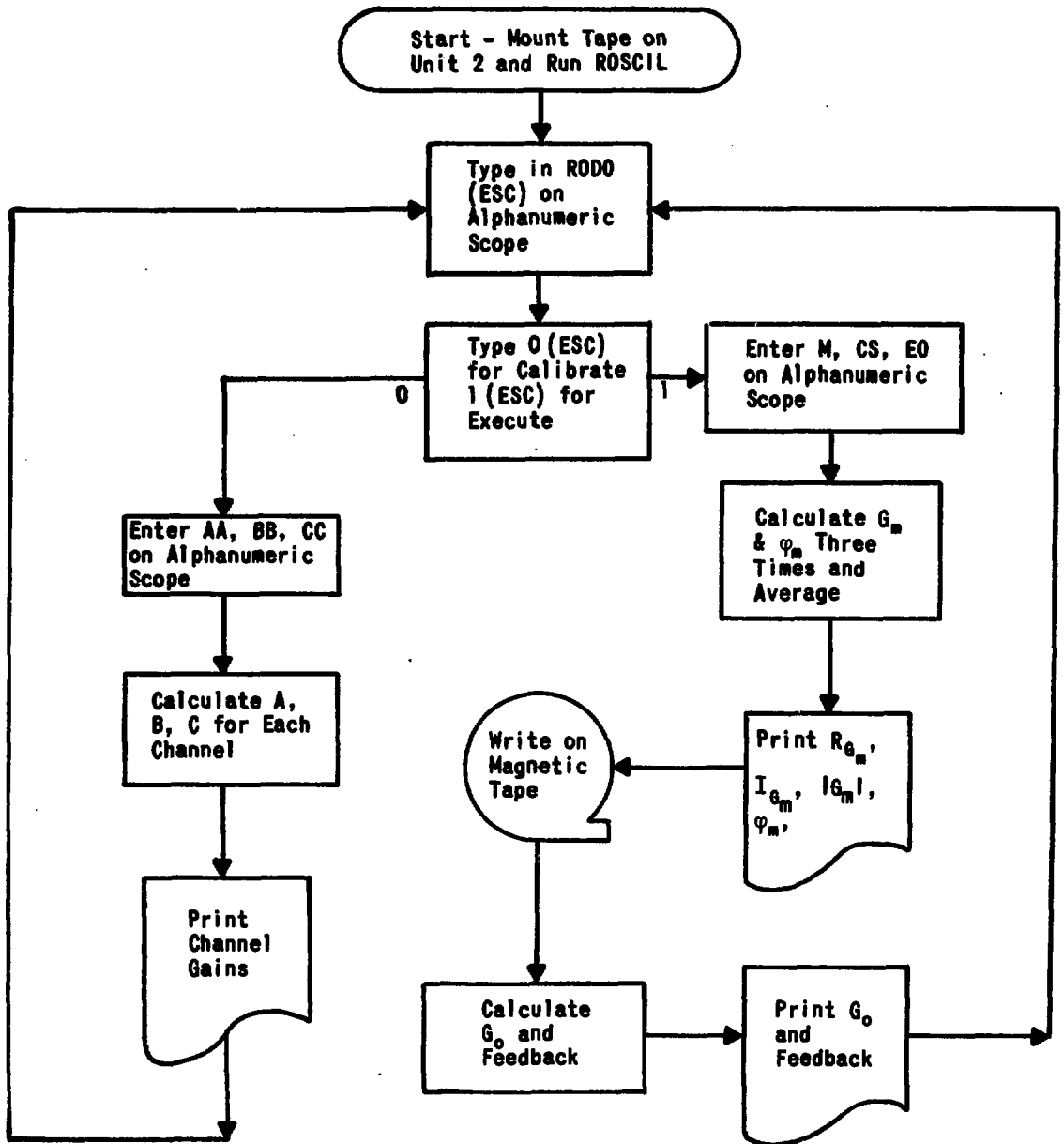

Fig. 6. Flowchart Describing Operation of ROSCIL (Rod-oscillator) Program

w	Frequency of oscillator in radians/sec
X <sub>m</sub>	Measured value
X <sub>0</sub>	Zero-power value
β	$\sum_{i=1}^6 \beta_i$
β <sub>i</sub>	i <sup>th</sup> precursor group delayed-neutron fraction
λ <sub>i</sub>	i <sup>th</sup> group decay constant
φ	Phase angle

The equations for the channel gains are:

$$A = \text{gain of ion-chamber channel} = \frac{1}{AA \cdot 2000} \sum_{i=1}^{2000} (\text{channel 1})t$$

$$B = \text{gain of cosine channel} = \frac{1}{BB \cdot 2000} \sum_{i=1}^{2000} (\text{channel 2})t$$

$$C = \text{gain of sine channel} = \frac{1}{CC \cdot 2000} \sum_{i=1}^{2000} (\text{channel 3})t$$

The equations for the zero-power transfer function (G<sub>0</sub>) are:

$$G_0 = \left[ s(\ell^* + \sum_{i=1}^6 \frac{\beta_i}{s + \lambda_i}) \right]^{-1};$$

$$R\left(\frac{1}{G_0}\right) = s \left( \sum_{i=1}^6 \frac{\beta_i}{s + \lambda_i} \sin\left(\frac{s}{\lambda_i}\right) \right); \quad I\left(\frac{1}{G_0}\right) = s \left( \ell^* + \sum_{i=1}^6 \frac{\beta_i}{s + \lambda_i} \cos\left(\frac{s}{\lambda_i}\right) \right);$$

$$|G_0| = \frac{1}{\sqrt{R\left(\frac{1}{G_0}\right) \cdot R\left(\frac{1}{G_0}\right) + I\left(\frac{1}{G_0}\right) \cdot I\left(\frac{1}{G_0}\right)}};$$

$$\phi_{G_0} = - \left\{ \text{ARCTAN} \left[ \frac{I\left(\frac{1}{G_0}\right)}{R\left(\frac{1}{G_0}\right)} \right] + \frac{\pi}{2} \right\}.$$

The equations for the transfer function at power ( $G_m$ ) are:

$$R_{G_m} = \frac{\sum_{i=1}^N \Delta E O_i \cos wt_i}{N \cdot A \cdot B \cdot E O} ; \quad I_{G_m} = \frac{\sum_{i=1}^N \Delta E O_i \sin wt_i}{N \cdot A \cdot C \cdot E O} ;$$

$$|G_m| = \left( \overline{R_{G_m}^2} + \overline{I_{G_m}^2} \right)^{0.5} ; \quad \phi_m = \text{ARCTAN} \left( I_{G_m} / R_{G_m} \right) .$$

The gain- and phase-normalizing factors are calculated by:

$$KK1 = G_o / G_m \quad \text{and} \quad KK2 = \phi_o - \phi_m .$$

The feedback component H is calculated by:

$$R_H = R \left( \frac{1}{G_m} \right) - R \left( \frac{1}{G_o} \right) ; \quad I_H = I \left( \frac{1}{G_m} \right) - I \left( \frac{1}{G_o} \right) ;$$

$$|H| = \left( \overline{R_H^2} + \overline{I_H^2} \right)^{0.5} ; \quad \phi_H = \text{ARCTAN} (I_H / R_H) .$$

APPENDIX A

Mathematical Analysis for Inverse-kinetics Calculations

Let

$$\frac{dn(t)}{dt} = \frac{k_{ex}(t)(1 - \beta) - \beta}{l^*} n(t) + \sum_{i=1}^6 \lambda_i c_i^*(t), \quad (A-1)$$

$$\frac{dc_i^*(t)}{dt} = \frac{k_{ex}(t) + 1}{l^*} \beta a_i n(t) - \lambda_i c_i^*(t), \quad i=1,2,\dots,6 \quad (A-2)$$

and, initially,

$$c_i^*(0) = \frac{\beta a_i}{\lambda_i} n_o. \quad (A-3)$$

Define:

$$\begin{aligned} c_i(t) &\equiv c_i^*(t) - c_i^*(0) \\ &= c_i^*(t) - c_{io}^* \end{aligned}$$

then,

$$c_i(0) = 0.$$

First work with Eq. (A-2) and substitute Eq. (A-3):

$$\frac{dc_i(t)}{dt} = \frac{k_{ex}(t) + 1}{l^*} \beta a_i n(t) - \lambda_i c_i(t) - \frac{\beta a_i n_o}{l^*}.$$

Integrate from  $t_o$  to  $t$ , evaluate at  $t = t + h$ , and use two-point trapezoidal integration:

$$\begin{aligned} c_i(t + h) &= e^{-\lambda_i h} \left[ c_i(t) + \frac{\beta a_i}{l^*} \cdot \frac{h}{2} \left\{ [k_{ex}(t) + 1]n(t) - n_o \right\} \right] \\ &\quad + \frac{\beta a_i}{l^*} \left\{ [k_{ex}(t + h) + 1] n(t + h) - n_o \right\} \frac{h}{2}. \end{aligned} \quad (A-4)$$

Application of Eq. (A-4) to Eq. (A-1) now gives

$$\begin{aligned} \frac{dn(t)}{dt} &= \frac{k_{ex}(t)(1-\beta) - \beta}{\ell^*} n(t) + \frac{\beta}{\ell^*} n_o + \sum_{i=1}^6 \lambda_i c_i(t) \\ &= -\frac{\beta}{\ell^*} [k_{ex}(t) + 1] n(t) + n_o \frac{\beta}{\ell^*} + \frac{k_{ex}(t)}{\ell^*} n(t) \\ &\quad + \sum_{i=1}^6 \lambda_i c_i(t). \end{aligned} \tag{A-5}$$

Now, apply to Eq. (A-5) a three-point derivative formula to produce the equation

$$\begin{aligned} \frac{n(t+2h) - n(t)}{2h} &= \frac{k_{ex}(t+h)}{\ell^*} n(t+h) \left[ 1 - \beta + \frac{h}{2} \sum_{i=1}^6 \lambda_i \beta a_i \right] \\ &\quad + \frac{[n(t+h) - n_o]}{\ell^*} \left[ 1 - \beta + \frac{h}{2} \sum_{i=1}^6 \lambda_i \beta a_i \right] \\ &\quad - \frac{n(t+h) - n_o}{\ell^*} + \sum_{i=1}^6 \lambda_i e^{-\lambda_i h} \\ &\quad \left[ c_i(t) + \frac{\beta a_i}{\ell^*} \frac{h}{2} \left\{ [k_{ex}(t) + 1]n(t) - n_o \right\} \right]. \end{aligned}$$

Define

$$\phi^{-1} = \left[ 1 - \beta \left( 1 - \frac{h}{2} \sum_{i=1}^6 \lambda_i a_i \right) \right].$$

Multiply through by  $\ell^*$  and collect terms:

$$\begin{aligned} k_{ex}(t+h) n(t+h) \phi^{-1} &= -[n(t+h) - n_o][\phi^{-1} - 1] \\ &\quad + \ell^* \frac{n(t+2h) - n(t)}{2h} - \sum_{i=1}^6 \lambda_i e^{-\lambda_i h} \end{aligned}$$

$$\left[ \lambda^* c_i(t) + \beta a_i \frac{h}{2} \left\{ [k_{\text{ex}}(t) + 1]n(t) - n_o \right\} \right].$$

Divide by  $n(t + h)$  and multiply by  $\phi$ :

$$k_{\text{ex}}(t + h) = \phi \left\{ \frac{\lambda^* \frac{n(t + 2h) - n(t)}{2h} - \sum_{i=1}^6 \lambda_i e^{-\lambda_i h} \left[ \lambda^* c_i(t) \right]}{n(t + h)} \dots \right. \\ \left. \dots \frac{+ \frac{h}{2} \left( \frac{[k_{\text{ex}}(t) + 1]n(t) - n_o}{n(t + h)} \beta a_i \right)}{n(t + h)} \right\} + \frac{n(t + h) - n_o}{n(t + h)} (\phi - 1).$$

(A-6)

Equations (A-4) and (A-6) are those programmed in the Sigma-5 version of the inverse-kinetics code.

APPENDIX B

Mathematical Analysis of Rod-drop Curve Fit

To program Eq. (4) for the computer, the inverse transform of Eq. (3) is taken:

$$h(\theta) = \sum_{i=1}^I \frac{A_i}{\tau_i} e^{-(\theta - T_i)/\tau_i} U(\theta - T_i), \quad (B-1)$$

where

$U(\theta - T_i)$  is the Heaviside unit step function

$$U(\beta) = \begin{cases} 0; & \beta < 0 \\ 1; & \beta \geq 0 \end{cases}$$

The time interval  $(0, t)$  of Eq. (4) is divided into  $N$  parts of width  $h$  such that  $t = Nh$ . Further, each delay operator  $T_i$  is assumed to be of magnitude  $\ell_i h$ , with  $\ell_i$  an integer, so that Eq. (4) becomes

$$\begin{aligned} FB(t) &= \sum_{i=1}^I \frac{A_i}{\tau_i} \int_0^{(N - \ell_i)h} e^{-[(N - \ell_i)h - \tau]/\tau_i} P(\tau) d\tau \\ &\approx \sum_{i=1}^I \frac{A_i}{\tau_i} \sum_{j=1}^{N - \ell_i} P(jh) \int_{(j-1)h}^{jh} e^{-[(N - \ell_i)h - \tau]/\tau_i} d\tau, \end{aligned} \quad (B-2)$$

where  $P(\tau) \approx P(jh)$  over  $(j-1)h < \tau < jh$ . Hence the integral of (B-2) may now be integrated:

$$FB(t) = \sum_{i=1}^I A_i \left[ 1 - e^{-h/\tau_i} \right] \sum_{j=1}^{N - \ell_i} P(jh) e^{-(N - \ell_i - j)h/\tau_i}. \quad (B-3)$$

APPENDIX C

Code Listing of Programs

<u>Program</u>	<u>Page No.</u>
RCL	39
FBCK	45
RPL	59
MODEL	63
ROSCIL	67

**PROGRAM RCL**

VERSION C00

```
C      PROGRAM RCAL FOR 200 SAMPLES/SEC          500 POINTS
DIMENSION P( 500),SS( 500),DK( 500),AW(6,81),RPS( 81),A(6),DC(6
X  SJ(6),EPM(6),R(6),EN(6),RI(6),TI(6),PT(9)
DATA  A/.032804,.19812,.18298,.40196,.14782,.036309/
DATA DC/.0127,.0317,.115,.311,1.4,3.87/
6001  CONTINUE
      READ 1, NPC,NWCS,IRBETA
      READ 4001,(PT(I),I=1,9)
C
C      NPC = # DROPS,    NWCS = # WORTH CURVE POSITION STEPS (.LE.80)
C      IRBETA NEGATIVE TO READ IN BETA(I),LAMBDA(I)....A(I),DC(I).....
C
      IF(IRBETA.GE.0) GO TO 2
      READ 4000,( A(I),I=1,6)
      READ 4000,(DC(I),I=1,6)
2     IDR=0
      N=NWCS+1
      DO 3 I=1,N
3     SS(I)=0.
      AWCS=NWCS
      PRINT 4, (A(I),I=1,6)
      PRINT 5, (DC(I),I=1,6)
      PRINT 3999
      DO 3000 JKL = 1,NPC
      READ 6,RUN,DRBP,POWER,FLOW,BSV,GAIN,DT,WCON
      IF(DT.LT.0) GO TO 1900
      IDR=IDR+1
      PRINT 6,RUN,DRBP,POWER,FLOW,BSV,GAIN,DT,WCON
      BSG=10.0/GAIN*BSV*3276.7
      DO 7 I=1,6
      X=-DT*DC(I)/2.
      EPM(I)= EXP(X)
      X=-2.*X
      R(I)= EXP(X)
      RI(I)=1./R(I)
      EN(I)=1.
7     SJ(I)=0.
C.....POWER INPUT
      CALL BUFFER IN(2,1,P(1), 500,INP,NPP)
      Z=P(1)+BSG
      DO 8 I=1,500
8     P(I)=(P(I)+BSG)/Z
      DK(1)=0.
      DO 11 J=1,499
      SI=0.
      DO 10 I=1,6
      EPM(I)=EPM(I)*R(I)
      SJ(I)=SJ(I)+(2.-P(J)=P(J+1))*EPM(I)*DT/2.
      EN(I)=EN(I)*RI(I)
10    SI=SI+A(I)*DC(I)*EN(I)*SJ(I)
```

11 DK(J+1)=(1.-P(J+1)-SI)/P(J+1)

C.....POSITION INPUT

```
CALL BUFFER IN(2,1,P(1), 500,INP,NPP)
S1=0.
S2=0.
DO 15 I=1,75
15 S1=S1+P(I)
DO 16 I= 471,500
16 S2=S2+P(I)
A2=S2/30.
DEL=S1/5. -A2
DO 17 I=1,500
17 P(I)=(P(I)-A2)/DEL
L1=1
DO 60 I=1,NWCS
W=I-1
A1=W/AWCS
AI=1.-A1
DO 50 J=L1,500
IF(J.GT.1) GO TO 47
CW=C.
L1=2
GO TO 59
47 L1=J
IF(AI=P(J))50,48,48
48 D=P(J-1)-P(J)
IF(D.LE.(.0009))GO TO 51
CW=DK(J-1)+(DK(J)-DK(J-1))/(P(J)-P(J-1))*(AI-P(J-1))
GO TO 59
51 CW=(DK(J-1)+DK(J))/2.
GO TO 59
50 CONTINUE
59 CONTINUE
S5(I)=S5(I)+CW
AW(IDR,I)=CW*WCON
60 CONTINUE
S2=0.
A1=1.
DO 70 J= 471,500
70 S2=S2+DK(J)
CW=S2/30.
AW(IDR,N)=S2/30.*WCON
S5(N)=S5(N)+CW
TI(IDR)=DRDP
GO TO 3000
1900 DO 1902 I=1,2
1902 CALL BUFFER IN(2,1,DUMM, 1,INP,NPP)
```

```
3000 CONTINUE
      IEND=IDR
      ANPC=IDR
      IDR=IDR+1
      DO 66 I=1,N
        B1=I-1
        B2=NWCS
        AK=B1/B2
        RPS(I)=AK
        AW(IDR,I)= S5(I)/ANPC*WCEN
66    CONTINUE
      PRINT 14
      PRINT 3998,(TI(I),I=1,IDR)
      DO 2500 I=1,N
2500  PRINT 3997,(RPS(I),AW(IDR,I),(AW(J,I),J=1,IEND))
      PRINT 71
C
C..... CARD OUTPUT FOR FBCK CODE
C
      PUNCH 4000,(AW(IDR,I),I=2,N)
C
C      PLOT RED CALIBRATION CURVES
C
      Y0=-.005
      YS= .005
C      XS=1.0/3.5
      XS=1.0/3.3
      X0=0.0
      CALL OFFSET(X0,XS,Y0,YS)
      DO 600 IK=1,2
C        CALL PLOT (0.0,6.,2)
C        CALL PLOT(3.5,6.,2)
C        CALL PLOT(3.3,6.,2)
C        CALL PLOT (3.5,0.,2)
C        CALL PLOT (3.3,0.,2)
C        CALL PLOT (0.0,0.,2)
        CALL PLOT(1.4,-0.5,3)
        CALL SYMBOL(1.4,-0.5,0.1,'POSITION (IN)',0.0,13)
        CALL PLOT( .5,-1.,3)
        CALL SYMBOL(0.5,-1.,0.12,'DROP RED CALIBRATION',0.0,20)
        CALL PLOT(0.5,-1.5,3)
        CALL SYMBOL(0.5,-1.5,0.125,PT ,0.0,32)
        CALL PLOT(=.63,2.8,3)
        CALL SYMBOL(=.63,2.8,0.1,'RED WORTH ($)',90.,13)
        CALL PLOT(0.0,0.,3)
      IK=0
      B2=N-1
      T=0.
      DO 520 I=1,N
        CALL PLOT(T,AW(IDR,I),12)
        B1=I
        T=B1/B2
520  CONTINUE
```

```
CALL PLBT(0.0,0.0,3)
CALL PLBT(0.0,0.0,3)
CALL NUPAGE(4.5)
600 CONTINUE
GO TO 6001
1  FORMAT(6I6)
4  FORMAT(1H1'BETA(I)/BETA... '6E14.5)
5  FORMAT(1H 'LAMBDA..... '6E14.5)
6  FORMAT(4(4X,A4),4E12.5)
14  FORMAT('0',' 75  PTS. AVERAGED AND SUBTRACTED',/)
71  FORMAT('0',' 30  POINTS AVERAGED FOR FINAL WORTH',/)
3997  FORMAT(1H ,F8.5,F11.5,6F12.5)
3998  FORMAT(1H , 'POSITION',6X'AVE',6(4X,A8),/)
3999  FORMAT(1H0, 3X,'RUN',5X'DROP',4X'POWER',3X'FLOW',5X'OSV',8X'GA
X ,10X'DT',6X'WORTH *',/)
4000  FORMAT(6E12.5)
4001  FORMAT(9A4)
      END
```

**PROGRAM FBCK**

```
C   PROGRAM FBCK=3 ( COMPUTES REACTIVITY FEEDBACK )
      DIMENSION FB(1320),POW(1320),POS(510),RAW(10),WC(41),
1     TI(18),RI(6),SJ(6),BET(6),DC(6),A(6),E(6)
      REAL*8 ALIF,ATM,AWC,BETA,DEN,DK,FZN,SI,TIM,TKEX1,WCV,      ZN0,ZN1
      COMMON ALIF,ATM,AWC,BETA,DEN,DK,FZN,SI,TIM,TKEX1,WCV,ZN0,ZN1,
1     CONW,      A,AK,BET,DC,DT, DT2,E,FB,FSUM,CSG,POS,POW,POWINT,PSUM,
2     R,R1S,R2S,R3S,RMBV,R3,RSUM,RAW,  SJ,TI,TKEX0,WC,IB,IBLK,ID,IHAM,
3     JJJ,K,NN,NNN,NOBETA,NOPOW,NP,NSTIN,NWC,NWCS
1     CONTINUE
      READ 4,NS
      NS = * OF SETS WHICH USE SAME CALIBRATION
      DO 10 JJJ=1,NS
      REWIND 1
      CALL SEGL00 (1)
      CALL INIB
      DO 5 LLL=1,NP
      REWIND 0
      CALL SEGL00 (2)
      CALL INPRNT
      CALL SEGL00 (3)
      CALL INITC
      DO 3 IB=1,IBLK
      CALL SEGL00 (4)
      CALL SM00
      IF(ID.LT.0) GO TO 3
      CALL SEGL00 (5)
      CALL FEED
3     CONTINUE
      IF(ID.LT.0)GO TO 5
      CALL SEGL00 (6)
      CALL FOOT1
5     CONTINUE
      CALL SEGL00 (7)
      CALL FOOT2
10    CONTINUE
      GO TO 1
4     FORMAT(16)
      END
```

```
. SUBROUTINE FOUT1
  DIMENSION FB(1320), POW(1320), POS(510), RAW(10), WC(41),
1 TI(18), R(6), SJ(6), BET(6), DC(6), A(6), E(6)
  REAL*8 ALIF, ATM, AWC, BETA, DEN, DK, FZN, SI, TIM, TKEX1, WCV, ZN0, ZN1,
  COMMON ALIF, ATM, AWC, BETA, DEN, DK, FZN, SI, TIM, TKEX1, WCV, ZN0, ZN1,
1 C0NW, A, AK, BET, DC, DT, DT2, E, FB, FSUM, GSG, POS, POW, POWINT, PSUM,
2 R, R1S, R2S, R3S, RM0V, RS, RSUM, RAW, SJ, TI, TKEX0, WC, IB, IBLK, ID, IHAM
3 JJJ, K, NN, NNN, N0BETA, N0P0W, NP, NSTIN, NWC, NWCS
  DO 100 NM=1,2
  REWIND 0
  SUM=0.0
  NST=NSTIN=5
  NI=1
  NB=6
  DO 80 J=1, IBLK
  GO TO(30,20), NM
20 CALL BUFFER IN(0,1,DUM,1,IST,ICN)
  CALL BUFFER IN(0,1,DUM,1,IST,ICN)
30 CALL BUFFER IN(0,1,FB, 500,IST,ICN)
  CALL BUFFER IN(0,1,FB(501),500,IST,ICN)
  GO TO(40,50), NM
40 CALL BUFFER IN(0,1,DUM,1,IST,ICN)
  CALL BUFFER IN(0,1,DUM,1,IST,ICN)
50 IF(NNN.EQ.0)GO TO 54
  GO TO (51,52), NM
51 PRINT 9
  GO TO 53
52 PRINT 11
53 PRINT 8, (FB(I), I=NST,1000)
54 IF(NB.EQ.6)GO TO 60
  DO 55 I=1, NB
55 SUM=SUM+FB(I)
  NST= 1+NB
  NB=6
  POW(NI)=SUM/6.
  SUM=0.0
  NI=NI+1
60 DO 70 I=NST,1000,6
  NK=I
  IF( I.GT.995)GO TO 71
  DO 65 KN=1,6
65 SUM=SUM+FB(KN=1+I)
  POW(NI)=SUM/6.
  SUM=0.0
  NI=NI+1
  NB=6
70 CONTINUE
71 IF(NK.EQ.995)GO TO 76
  DO 75 KN=NK,1000
  SUM=SUM+FB(KN)
```

```
75 CONTINUE
76 NB=NK-995
   IF(NB.EQ.0)NB=6
   NST=1
80 CONTINUE
   CALL BUFFER OUT(1,1,POW(1), 500,IST,ICN)
   CALL BUFFER OUT(1,1,POW(501), 500,IST,ICN)
   CALL BUFFER OUT(1,1,POW(1001), 300,IST,ICN)
   CALL BUFFER OUT(4,1,POW(1),1300,IST,ICN)
100 CONTINUE
   DDD=DT*6.
   NI=NI-1
   PRINT 1014      ,ID,DDD
   PRINT 8,(POW(I),I=1,NI)
   RETURN
8  FORMAT(10F12.5)
9  FORMAT('1  POWER',/)
11 FORMAT('1  FEEDBACK',/)
1014 FORMAT('1  THE  SIX-POINT AVERAGED FEEDBACK FOR DRBP NO',I6,
1  '  DT='F7.4,'X',1300  POINTS',/)
END
```

```

SUBROUTINE FOUT2
DIMENSION FB(1320),POW(1320),POS(510),RAW(10),WC(41),
1TI(18),R(6),SJ(6),BET(6),DC(6),A(6),E(6)
  REAL*8 ALIF,ATM,AWC,BETA,DEN,DK,FZN,SI,TIM,TKEX1,WCV,ZN0,ZN1,
COMMON ALIF,ATM,AWC,BETA,DEN,DK,FZN,SI,TIM,TKEX1,WCV,ZN0,ZN1,
1CONW,A,AK,BET,DC,DT,DT2,E,FB,FSUM,OSG,POS,POW,POWINT,PSUM,
2 R,R1S,R2S,R3S,ROV,RS,RSUM,RAW,SJ,TI,TKEX0,WC,IB,IBLK,ID,IHAM,
3 JJJ,K,NN,NNN,NOBETA,NOPOW,NP,NSTIN,NWC,NWCS
  AP0W=NOP0W
  PRINT 1024,NOP0W
  DO 100 NM=1,2
  REWIND 1
  DO 10 I=1,1320
10  POW(I)=0.0
  DO 80 J=1,NOP0W
  GO TO(30,20),NM
20  CALL BUFFER IN(1,1,DUM,1,IST,NST)
  CALL BUFFER IN(1,1,DUM,1,IST,ICN)
  CALL BUFFER IN(1,1,DUM,1,IST,ICN)
30  CALL BUFFER IN(1,1,FB,500,IST,ICN)
  CALL BUFFER IN(1,1,FB(501),500,IST,ICN)
  CALL BUFFER IN(1,1,FB(1001),300,IST,ICN)
  GO TO(40,50),NM
40  CALL BUFFER IN(1,1,DUM,1,IST,ICN)
  CALL BUFFER IN(1,1,DUM,1,IST,ICN)
  CALL BUFFER IN(1,1,DUM,1,IST,ICN)
50  DO 60 I=1,1300
60  POW(I)=POW(I)+FB(I)/AP0W
80  CONTINUE
  CALL BUFFER OUT(3,1,POW(1),500,IST,ICN)
  CALL BUFFER OUT(3,1,POW(501),500,IST,ICN)
  CALL BUFFER OUT(3,1,POW(1001),300,IST,ICN)
  CALL BUFFER OUT(4,1,POW(1),1300,IST,ICN)
  PRINT 8,(POW(I),I=1,1300)
  PRINT 1013,NOP0W
100  CONTINUE
  RETURN
  8  FORMAT(10F12.5)
1013  FORMAT('1 THE SIX- POINT AVERAGED FEEDBACK OVER ',I3,' DROPS A
? THIS POWER LEVEL IS',//)
1024  FORMAT('1 THE SIX-POINT AVERAGED POWER OVER ',I3,' DROPS IS',/
END
```

```
SUBROUTINE FEED
DIMENSION FB(1320),POW(1320),POS(510),RAW(10),WC(41),
1TI(18),R(6),SJ(6),BET(6),DC(6),A(6),E(6)
  REAL*8 ALIF,ATM,AWC,BETA,DEN,DK,FZN,SI,TIM,TKEX1,WCV,      ZN0,ZN1
COMMON ALIF,ATM,AWC,BETA,DEN,DK,FZN,SI,TIM,TKEX1,WCV,ZN0,ZN1,
1CONW,      A,AK,BET,DC,DT,DT2,E,FB,FSUM,OSG,POS,POW,POWINT,PSUM,
2 R,R1S,R2S,R3S,RMOV,RS,RSUM,RAW,  SJ,TI,TKEX0,WC,IB,IBLK,ID,IHAM,
3 JJJ,K,NN,NNN,NOBETA,NOPCW,NP,NSTIN,NWC,NWCS
  NST=NSTIN
  IF(IB.GT.1)NST=6
  INPOS=510
  IOPCW=1005
  DAK=AK
  DO 50 I= NST,IOPCW
  SI=0.
  DO 36 J=1,NOBETA
36 SI=E(J)*(ALIF*SJ(J)+(TKEX0+1.0)*BET(J)*ZN0*DT2-DT2*BET(J)*FZN)+SI
  TKEX1=DEN*SI/ZN1+(ZN1-FZN)*(DEN-1.0)/ZN1
  DK=-TKEX1/BETA
  DO 38 J=1,NOBETA
38 SJ(J)=R(J)*(SJ(J)+DT2*((TKEX0+1.0)*ZN0-FZN)*BET(J)/ALIF)+DT2*((
1 TKEX1+1.0)*ZN1-FZN)*BET(J)/ALIF
  TKEX0=TKEX1
  ZN0=ZN1
  ZN1=FB(I+1)
  IF(IB.GT.1)GO TO 47
  IF(1.GT.INPOS)GO TO 47
40 IF(1.0.LE.POS(I)) GO TO 47
  IF(POS(I).LE.AK) GO TO 44
  AK=AK+DAK
  K=K+1
  GO TO 40
44 WCV=WC(K-1)+(WC(K)-WC(K-1))*(DAK-AK+POS(I))/DAK
  GO TO 48
47 WCV=WC(NWC)
48 FB(I)=WCV-DK
49 CONTINUE
  IF(ATM.GT.5.5)GO TO 50
  R3S=R2S
  R2S=R1S
  R1S=DK
  IF(I/NN.NE.1)GO TO 50
  NN=NN+2
  IF(I.LT.(NST+2).AND.IB.EQ.1)GO TO 50
  TIM=TIM+2.*DT
  FSUM=FSUM+DT *.33333*(FB(I-2)+4.0*FB(I-1)+FB(I))
  PSUM=PSUM+ DT *.33333*(POW(I-2)+4.*POW(I-1)+POW(I) -6.0*POWINT)
  RSUM=RSUM+DT *.33333*(R3S+4.*R2S+R1S)
  IF(TIM.LT.ATM)GO TO 50
  BRAT=+DK/PSUM
```

```
BR0T=RSUM/PSUM
ATM=ATM+0.5
PRINT 1020,TIM,RSUM,PSUM,FSUM,BRAT,BROT
C PUNCH 2,TIM,RSUM,PSUM,FSUM,BRAT,BROT
IDUM=I+1
50 CONTINUE
CALL BUFFER OUT(0,1,FB(5),500,IST,ICN)
CALL BUFFER OUT(0,1,FB(506),500,IST,ICN)
NN=7
IF (IDUM.EQ.1005)NN=6
RETURN
2 FORMAT(6E12.5)
1020 FORMAT(F12.4,5E16.5)
END
```

```

SUBROUTINE SM00
DIMENSION FB(1320),P0W(1320),P0S(510),RAW(10),WC(41),
1TI(18),R(6),SJ(6),BET(6),DC(6),A(6),E(6)
REAL*8 ALIF,ATM,AWC,BETA,DEN,DK,FZN,SI,TIM,TKEX1,WCV,X,X1,ZN0,ZN1,
COMMON ALIF,ATM,AWC,BETA,DEN,DK,FZN,SI,TIM,TKEX1,WCV,ZN0,ZN1,
1CONW, A,AK,BET,DC,DT,DT2,E,FB,FSUM,0SG,P0S,P0W,P0WINT,PSUM,
2 R,R1S,R2S,R3S,RM0V,RS,RSUM,RAW, SJ,TI,TKEX0,WC,IB,IBLK,ID,IHAM
3 JJJ,K,NN,NNN,N0BETA,N0P0W,NP,NSTIN,NWC,NWCS

```

```
INP0W=1010
```

```
I0P0W=1009
```

```
DO 5 I=,10
```

```
5 FB(I)=RAW(I)
```

```
IF ID NEGATIVE SKIP COMP OF FEEDBACK
```

```
POWER INPUT .....
```

```
CALL BUFFER IN(2,1,FB(11), 1000,IS,LL)
```

```
IF(ID.LT.0)RETURN
```

```
DO 18 I=11,INP0W
```

```
18 FB(I)=FB(I)+0SG
```

```
IF(IB.G1.1)GO TO 29
```

```
ZN0=1.0
```

```
RS=0.
```

```
DO 19 I=11,60
```

```
19 RS=RS+FB(I)
```

```
RS=RS*.02
```

```
29 CONTINUE
```

```
DO 30 I=11,INP0W
```

```
30 FB(I)=FB(I)/RS
```

```
DO 31 I=1,10
```

```
31 RAW(I)=FB(I+1000)
```

```
IF(IHAM.EQ.0) GO TO 34
```

```
DO 33 J=1,IHAM
```

```
X1=FB(2)
```

```
X=FB(1)
```

```
DO 32 I= 2,I0P0W
```

```
FB(I)=.54*X1+.23*(X+FB(I+1))
```

```
X=X1
```

```
32 X1=FB(I+1)
```

```
FB(INP0W)=(FB(INP0W)+FB(I0P0W))*0.5
```

```
33 FB( I )=(FB( I )+FB( 2 ))*0.5
```

```
FB(5)=ZN0
```

```
34 IF(IB.G1.1)GO TO 36
```

```
P0WINT= .0
```

```
DIVI=10.
```

```
DO 35 I=11,20
```

```
35 P0WINT=P0WINT+FB(I)
```

```
P0WINT=P0WINT/DIVI
```

```
C      OUTPUT POWER TO UNIT 0
36     CALL BUFFER OUT(0,1,FB(6), 500,IST,ICN)
      CALL BUFFER OUT(0,1,FB(506), 500,IST,ICN)
C
      DO 37 I=1,1010
37     POW(I)=FB(I)
      ZN1=FB(6)
      RETURN
      END
```

```
SUBROUTINE INITC
DIMENSION FB(1320),POW(1320),POS(510),RAW(10),WC(41),
1 TI(18),R(6),SJ(6),BET(6),DC(6),A(6),E(6)
REAL*8 ALIF,ATM,AWC,BETA,DEN,DK,FZN,SI,TIM,TKEX1,WCV,      ZN0,ZN1
COMMON ALIF,ATM,AWC,BETA,DEN,DK,FZN,SI,TIM,TKEX1,WCV,ZN0,ZN1,
1CONW,      A,AK,BET,DC,DT,DT2,E,FB,FSUM,OSG,POS,POW,POWINT,PSUM,
2 R,R1S,R2S,R3S,RMOV,RS,RSUM,RAW, SJ,TI,TKEX0,WC,IB,IBLK,ID,IHAM,
3 JJJ,K,NN,NNN,N0BETA,N0POW,NP,NSTIN,NWC,NWCS
TKEX0=0.0
DO 3 I=1,10
3 RAW(I)=.0
FZN=1.
K=2
AWC=NWC-1
AK =1./AWC
R1S=0.0
R2S=0.0
R3S=0.0
PSUM=0.0
RSUM=0.0
FSUM=0.0
TIM=0.0
TU=0.
ATM=0.4999
```

POSITION INPUT .....

CALL BUFFER IN(2,1,POS(11), 500,IS,LL)

```
IF(ID.LT.0)RETURN
INPOS=510
N0POW=N0POW+1
DO 5 I=1,N0BETA
5 CONTINUE
SJ(I)=0.0
DO 10 I=11,60
10 TU=TU+POS(I)
VU=0.
ISEN=INPOS-29
DO 11 I=ISEN,INPOS
11 VU=VU+POS(I)
FAC3=VU/30.+2.
FAC1=TU*.02 +2.-FAC3
NST=61
DO 14 I=11,INPOS
POS(I)=((POS(I))+2.-FAC3)/FAC1
IF(POS(I).GE.RMOV)NST=I
14 CONTINUE
NN=NST
NSTIN=NST
```

```
NST=NST-10
PRINT 4, NST
NST=NST+10
ISEN=NST+199
PRINT 8, (PDS(I), I= NST, ISEN)
PRINT 1019
DO 26 I=11, INPDS
26 PDS(I)=1.-PDS(I)
DO 27 I=1, 10
27 PDS(I)=PDS(11)
RETURN
4 FORMAT(2I6)
8 FORMAT(10F12.5)
1019 FORMAT('1 REACTIVITY, POWER-CHANGE, FEEDBACK INTEGRALS', //7X' TIME',
* 6X'INT OF RHO INT OF DELTA=P INT OF FEEDBACK RHO/(INT DP)
*INT RHO/(INT DP)')
END
```

```
SUBROUTINE INPRNT
DIMENSION FB(1320),POW(1320),POS(510),RAW(10),WC(41),
1TI(18),R(6),SJ(6),BET(6),DC(6),A(6),E(6)
  REAL*8 ALIF,ATM,AWC,BETA,DEN,DK,FZN,SI,TIM,TKEX1,WCV,      ZN0,ZN1
  COMMON ALIF,ATM,AWC,BETA,DEN,DK,FZN,SI,TIM,TKEX1,WCV,ZN0,ZN1,
1CONW,      A,AK,BET,DC,DT, DT2,E,FB,FSUM,OSG,POS,POW,POWINT,PSUM,
2 R,R1S,R2S,R3S,RMOV,RS,RSUM,RAW,  SJ,TI,TKEX0,WC,IB,IBLK,ID,IHAM,
3 JJJ,K,NN,NNN,NOBETA,NOPOW,NP,NSTIN,NWC,NWCS
  READ 13,OSV,GAIN,ID
  IF(ID.LT.0)RETURN
  OSG=10.0/GAIN * OSV * 3276.7
  PRINT 21,(TI(I),I=1,18)
  PRINT 71,(A(I),I=1,NOBETA)
  PRINT 72,(DC(I),I=1,NOBETA)
  PRINT 73,BETA,ALIF
  PRINT 22,CONW
  PRINT 23,DT,OSV,GAIN,ID
  PRINT 24
  PRINT 8,(WC(I),I=1,NWC)
  PRINT 25
  RETURN
 8  FORMAT(10F12.5)
13  FORMAT(.E12.5,I6)
21  FORMAT('1',1X,18A4)
22  FORMAT('0 WORTH = ',F12.6,/)
23  FORMAT('0 DT(SEC) = ',F12.5,' OSV = ',F12.5,' GAIN = ',F12.5,
1' R0D DR0P N0. ',I6,/)
24  FORMAT('0 R0D CALIBRATION IS',/)
25  FORMAT('0 NORMALIZED POSITION IS',/)
71  FORMAT(1H 'BETA(I)/BETA...',6E14.5)
72  FORMAT(1H 'LAMBDA.....',6E14.5)
73  FORMAT(1H 'BETA.....',E14.5,14X,'LIFETIME.....',E14.5)
  END
```

```

SUBROUTINE IN18
DIMENSION F(1320),P(1320),POS(1320),RAM(10),MC(4)
11(18),R(6),SU(6),BET(6),DC(6),A(6),E(6)
REAL*8 ALF,ATM,AWC,BETA,DEN,DK,FZN,SI,TIM,TKEX1,WCV,ZN0,ZN1
COMMON ALF,ATM,AWC,BETA,DEN,DK,FZN,SI,TIM,TKEX1,WCV,ZN0,ZN1,
ICNM, A,K,BET,DC,DT,DI2,E,FB,FSUM,OSG,POS,PM,PMINT,PSUM,
2 R,RIS,R2S,R3S,RMV,RS,RSUM,RAW, SJ,TI,TKEXD,WC,IB,IBLK,ID,IHAM,
3 JUC,K,NN,NNN,NOBETA,NP,NM,NSIN,WC,NMCS
A(1)=.032804
A(2)=.19812
A(3)=.18298
A(4)=.40196
A(5)=.14782
A(6)=.036309
DC(1)=.0127
DC(2)=.0317
DC(3)=.115
DC(4)=.311
DC(5)=1.40
DC(6)=3.87
MC(1)=0.0
NBPW=0
READ 1,(TI(I),I=1,18)
READ 4,MC, IHAM,NN,NP,NOBETA, IBLK
MWC = * WORTH POINTS .....
IHAM = 0 .. NO HAMMING
NNN NONZERO TO PRINT POWER,FEEDBA
NP = * DROP RECORDS TO CONSIDER .....
IF NOBETA NEGATIVE READ NEW BETA(I)/BETA, AND DECAY CONSTANTS
IBLK = * BLOCKS OF POWER/ DROP
IF(NOBETA.GT.0) GO TO 5
NOBETA=-NOBETA
READ 2,(A(I),I=1,NOBETA)
READ 2,(DC(I),I=1,NOBETA)
READ 2,ALF,BETA,CNM,DT,RMV
CNM = WORTH MULTIPLIER
RMV = MIN RDP POS TO INITIATE FEEDBACK CALCULATION
DEN=0.0
DO 10 I=1,NOBETA
BET(I)=A(I)*BETA
DEN=DEN+DC(I)*BET(I)
R(I) = EXP(-DC(I)*DT)
E(I)=-DC(I)*R(I)
DI2=0.5*DI
DEN=1.0/(1.0-BETA+DI2*DEN)
IF(JJ.GT.1) GO TO 18
READ 2,(MC(I),I=2,NM)
DO 17 I=2,NM
MC(I)=MC(I)*CNM
17 MC(I)=MC(I)*CNM
18 NMCS=MC - 1
RETURN
1 FORMAT(8A+)
2 FORMAT(6E12.5)
4 FORMAT(2I6)
END

```

**PROGRAM RPL**

VERSION COO

REAL\*8 XTI,XTF,YLI,YLF,YRI,YRF  
DIMENSION P(1400),PT(18)  
CALL LIMITS(-2.5,7.5)

C

C..... PROGRAM PLOTS REACTIVITY FEEDBACK, POWER FROM BINARY TAPE

C

C.....NG = # GRAPH GRIDS , NPG = # PLOTS/GRID  
C.....NP = # OF POINTS TO PLOT NI = # OF POINTS INPUT( BUFFERED IN )

```
1 READ 100, NG,NPG,NP,NI
  READ 99,(PT(I),I=1,18)
  IF(NG.EQ.0)GO TO 5000
  READ 98,DX
  READ 98,TMN,TMX,TD,PMN,PMX,PD,RMN,RMX,RD
  READ 297,XTI,XTF,YLI,YLF,YRI,YRF
  X0=TMN
  XS=(TMX-TMN)/8.
  DO 200 IK=1,NG
    CALL PLOT(8.,0.0,2)
    CALL PLOT(8.0,5.,2)
    CALL PLOT(0.0,5.,2)
    CALL PLOT(0.0,0.,2)
    CALL SYMBOL(-0.12,-0.20,0.1,XTI,0.0,6)
    CALL SYMBOL(-0.6,-0.05,0.1,YLI,0.0,6)
    CALL SYMBOL(-1.0,1.8,0.1,'FEEDBACK(*)',90.,11)
    CALL SYMBOL(-0.6,4.95,0.1,YLF,0.0,6)
    CALL SYMBOL(2.8,4.0,0.1,'POWER',0.0,5)
    CALL SYMBOL(2.8,1.00,0.1,'FEEDBACK',0.0,8)
    CALL SYMBOL(2.8,-0.5,0.1,' TIME (SEC)',0.0,11)
    CALL SYMBOL(1.4,-0.8,0.1,'POWER,NEGATIVE FEEDBACK',0.0,23)
    CALL SYMBOL(1.4,-1.1,0.12,PT(1),0.0,48)
    CALL SYMBOL(7.85,-0.20,0.1,XTF,0.0,6)
    CALL SYMBOL(8.1,-0.05,0.1,YRI,0.0,6)
    CALL SYMBOL(8.0,1.7,0.1,'NORMALIZED POWER',90.,16)
    CALL SYMBOL(8.1,4.95,0.1,YRF,0.0,6)
    CALL PLOT(0.0,0.,3)
    X=0.0
    Y=5.
    NM=(TMX-TMN)/TD+0.1
    AM=NM
    DD=8./AM
    IF(NM.EQ.1)GO TO 1311
    DO 1305 I=1,NM
      X=X+DD
      Y=5.-Y
      CALL PLOT(X,Y,2)
      Y=5.-Y
      CALL PLOT(X,Y,2)
      Y=5.-Y
      CALL PLOT(0.0,0.0,3)
      X=8.
```

1305

```
Y=0.0
NM= (RMX-RMN)/RD+0.1
AM=NM
DD=5./AM
DO 1310 I=1,NM
X=8.*X
Y=Y+DD
CALL PLOT(X,Y,2)
X=8.*X
CALL PLOT(X,Y,2)
1310 X=8.*X
1311 CALL PLOT(0.0,0.0,3)
DO 199 JK=1,2
CALL BUFFER IN(2,1,P,NI,IS,LL)
133 F0RMA1( 0E12.5)
IF(JK.EQ.2)GO TO 160
Y0=PMN
YS=(PMX-PMN)/5.
GO TO 161
160 Y0=RMN
YS=(RMX-RMN)/5.
161 CONTINUE
DT=DX
CALL OFFSET(X0,XS,Y0,YS)
T=0.
CALL PLOT(T,P(1),3)
DO 166 I=1,NP
CALL PLOT(T,P(I),12)
T=T+DT
166 CONTINUE
CALL PLOT(0.,0.,3)
199 CONTINUE
CALL PLOT(0.,0.,3)
CALL NUPAGE(3.5)
200 CONTINUE
GO TO 1
5000 CONTINUE
98 F0RMA1(10F8.0)
99 F0RMA1( .8A4)
100 F0RMA1(10I6)
297 F0RMA1(6A8)
END
```

**PROGRAM MODEL**

VERSION C00

```
C   FEEDBACK MODEL = 7 TERMS UP TO 3 TRANSPORTS   NOV 10, 1970
C
  DIMENSION A(7),X(400),Y(400),Z(400),B(7),C(7),R(666),RD(7),AM(7)
  XAB(7),P(666)
1000 READ 1, N,DT
      READ 4,XMIN,XMAX,XL,XD,YMIN,YMAX,YL,YD
      X0=XMIN
      XS=(XMAX-XMIN)/XL
      Y0=YMIN
      YX=(YMAX-YMIN)/YL
      CALL OFFSET(X0,XS,Y0,YX)
      CALL BUFFER IN(2,1,P,N,IS,IL)
      CALL BUFFER IN(2,1,R,N,IS,IL)

C
C   FBPL .LE. 0. TO INITIATE NEW GRID, .LE. 0 TO PLOT INPUT,
C   .GT. 0. TO PLOT MODEL
C   N = # POINTS ,   DT = TIME STEP       T1,2,3 = DELAY TIMES
C   FMUL = MULTIPLIER FOR PLOT DATA
C
100 READ 4,T1,T2,T3,FBPL,FMUL
    T = YMAX
    IF(FBPL .GT. 0. )GO TO 3
    CALL PLOT(XL,0.0,2)
    CALL PLOT(XL,YL,2)
    CALL PLOT(0.0,YL,2)
    CALL PLOT(0.0,0.0,2)
    3  CALL PLOT(XMIN,YMAX,13)
      IF(FBPL.LT.0.)GO TO 5
      READ 1,NTC
      READ 4,(A(I),I=1,NTC)
      READ 4,(RD(I),I=1,NTC)
      GO TO 15
    5  DO 10 J=1,N
10  R(J)=R(J)*FMUL
      CALL PLOT(R(1),T,13)
      DO 11 J=1,N
      CALL PLOT(R(J),T,13)
      CALL PLOT(R(J),T,12)
11  T=T-DT
      CALL PLOT(R(N),T,13)
      CALL PLOT(XMIN,YMIN,13)
      IF(FBPL.GT.10.) GO TO 1000
      GO TO 100

C
C   PLOT MODEL
C
15  T4=0.0
    EE=2.7182818
    DO 16 I=1,NTC
```

```
RD(I)=-1.0/RD(I)
AM(I)=EE*(DT*RD(I))
AB(I)=1.0-AM(I)
B(I)=0.0
16 C(I)=0.0
   C(4)=0.0
   C(5)=0.0
   C(6)=0.0
   C(7)=0.0
   J=1
   K=1
   L=1
   DO 50 I=1,N
     R(I)=P(I)
     R(I)=(1.0-R(I))*FMUL
     DO 18 MN=1,NTC
18  B(MN)=B(MN)+AM(MN)+R(I)*AB(MN)*A(MN)
     DO 19 MN=1,NTC
19  C(MN)=B(MN)
     S=C(4)+C(5)+C(6)+C(7)
     IF(T1 .NE. 0)GO TO 20
     S=S+C(1)
     GO TO 24
20  IF(T4 .GE. T1)GO TO 22
     X(J)=C(1)
     J=J+1
     GO TO 24
22  S=S+X(1)
     X(J)=C(1)
     N=J-1
     DO 23 MN=1,M
23  X(MN)=X(MN+1)
24  IF(T2 .NE. 0)GO TO 25
     S=S+C(2)
     GO TO 28
25  IF(T2 .LE. T4)GO TO 26
     Y(K)=C(2)
     K=K+1
     GO TO 28
26  S=S+Y(1)
     Y(K)=C(2)
     M=K-1
     DO 27 MN=1,M
27  Y(MN)=Y(MN+1)
28  IF(T3 .NE. 0)GO TO 29
     S=S+C(3)
     GO TO 32
29  IF(T3 .LE. T4)GO TO 30
     Z(L)=C(3)
     L=L+1
     GO TO 32
30  S=S+Z(1)
     M=L-1
```

```
Z(L)=C(S)
DO 31 MN=1,M
31 Z(MN)=Z(MN+1)
32 CALL PLBT(S,T,12)
   T4=T4+DT
50 T=T-DT
   CALL PLBT(S,T,13)
   CALL PLBT(0.0,0.0,3)
   CALL NUFACE(4.0)
   IF(FBPL.GT.10.) GO TO 1000
GO TO 100
6  FORMAT(12F6.4)
4  FORMAT(8E10.4)
2  FORMAT(6E12.5)
1  FORMAT(10,5E12.5)
END
```

**PROGRAM ROSCIL**

\*  
\* TRANSFER FUNCTION ANALYSIS USING ROD OSCILLATOR  
\*

	REF	9SIN,9COS,9ATAN2,9SQRT,CONEB	
	SREF	FP:MBOX,MAIN,MSET	
T11	RES	26	
T2	RES	26	
T3	RES	26	
T4	RES	26	
T5	RES	26	
CC1	DATA	X'04000059'	
	GEN,4,28	12,T11	
	DATA	CAL	
	DATA	10	
CC2	DATA	X'0400005A'	
	GEN,4,28	12,T2	
	DATA	ROD0	
	DATA	1	
CC3	DATA	X'04000070'	
	GEN,1,31	1,T3	
	DATA	ENTRY	
CC4	DATA	X'04000071'	
	GEN,1,31	1,T4	
	DATA	G0	
CC5	DATA	X'04000072'	
	GEN,1,31	1,T5	
	DATA	GONE	
ENTER	LI,14	4	
	BAL,15	MSET	
	DATA	NN	
	DATA	IHDL	
	DATA	ICNTR	
	DATA	IDATA	
	CAL1,5	CC3	CONNECTS TO 70 FOR INITIATE FROM SCOP
	CAL1,5	CC4	REENTER PORTION OF CALIBRATION
	CAL1,5	CC5	REENTER PORTION OF ROD0
	LI,3	0	
	STW,3	INFLAG	USED TO INDICATE WHETHER CONS ARE CAL
	LI,1	119	
	STB,1	PP2	
	LI,1	59	
	STB,1	PP5	
	CAL1,9	1	
INFLAG	RES	1	
ENTRY	LW,4	FP:MBOX+100	
	BEZ	G02	
	LW,6	=X'72'	
	STW,6	IL0C+1	
	LW,6	FP:MBOX+101	

TRANSFER FUNCTION ANALYSIS USING ROD OSCILLATOR

```
REF          9SIN,9COS,9ATAN2,9SQRT,CONEB
SREF        FP:MBOX,MAIN,MSET
RES         26
RES         26
RES         26
RES         26
RES         26
DATA        X'04000059'
GEN,4,28    12,T11
DATA        CAL
DATA        10
DATA        X'0400005A'
GEN,4,28    12,T2
DATA        ROD0
DATA        1
DATA        X'04000070'
GEN,1,31    1,T3
DATA        ENTRY
DATA        X'04000071'
GEN,1,31    1,T4
DATA        00
DATA        X'04000072'
GEN,1,31    1,T5
DATA        GONE
LI,14       4
BAL,15      MSET
DATA        NN
DATA        IHDL
DATA        ICNTR
DATA        IDATA
CAL1,5      CC3
CAL1,5      CC4
CAL1,5      CC5
LI,3        0
STW,3       INFLAG
LI,1        119
STB,1       PP2
LI,1        59
STB,1       PP5
CAL1,9      1
RES         1
LW,4        FP:MBOX+100
BEZ         002
LW,6        =X'72'
STW,6       IL0C+1
LW,6        FP:MBOX+101
```

CONNECTS TO 70 FOR INITIATE FROM SCOPE  
REENTER PORTION OF CALIBRATION  
REENTER PORTION OF ROD0

USED TO INDICATE WHETHER CONS ARE CALC.

2

LW,7 FP:MB0X+102  
LW,8 FP:MB0X+103  
LW,9 FP:MB0X+104  
LW,10 FP:MB0X+105  
LW,11 6  
FDS,11 =FS'2.1'  
STW,11 AM  
FAS,6 =FS'.5'  
LW,11 6  
AND,11 =X'0F000000'  
SLS,11 =24  
AND,6 =X'00FFFFFF'  
LI,2 6  
SW,2 11  
BEZ \*+3  
SLS,6 =4  
BDR,2 \*-1  
STW,6 TEMPM  
STW,7 CS  
STW,8 WC  
STW,9 F0  
STW,10 E0  
LI,6 0  
STW,6 ARS  
STW,6 AIS  
STW,6 AFS  
LI,6 3  
STW,6 NUM  
CAL1,2 PR3  
CAL1,2 PR6  
LW,7 INFLAG  
BNEZ \*+5  
LW,6 =FS'1.1'  
STW,6 KK1  
LI,6 0  
STW,6 KK2  
LW,7 TEMPM  
STW,7 M  
LI,1 INIT  
STW,1 RETURN  
STW,6 FR  
STW,6 FI  
STW,6 CONST  
STW,6 RMS  
STW,6 N  
CAL1,5 CC2  
CAL1,9 1  
RES 1  
RES 1

AGAIN

M  
AM

CONNECTS TO SA FOR DATA ACQUISITION

TEMPM RES 1  
NUM RES 1  
AIS RES 1  
ARS RES 1  
AFS RES 1  
DSA DATA X'0100005A'  
D59 DATA X'01000059'

\*  
\* CALIBRATION  
\*

G02 LW,6 FP:MB0X+101  
LW,7 FP:MB0X+102  
LW,8 FP:MB0X+103  
STW,6 AA  
STW,7 BB  
STW,8 CC  
LI,4 2000  
STW,4 COUNT  
LI,6 0  
STW,6 S1  
STW,6 S2  
STW,6 S3  
LW,6 =X'71'  
STW,6 ILEC+1  
CAL1,5 CC1  
CAL1,9 1

CONNECTS TO 59 FOR CALIBRATION

COUNT RES 1  
S1 RES 1  
S2 RES 1  
S3 RES 1  
AA RES 1  
BB RES 1  
CC RES 1  
A RES 1  
B RES 1  
C RES 1  
E0 RES 1  
N RES 1  
AN RES 1  
FR RES 1  
FI RES 1  
AMP RES 1  
ANG RES 1  
CONST RES 1  
FREQ RES 1  
KK1 RES 1  
KK2 RES 1  
GZAMP RES 1  
GZANG RES 1

WC	RES	1
F0	RES	1
CS	RES	1
CAL	B	GDAT
GB	LI,1	1
	LH,6	IDATA,1
	LH,7	IDATA+1
	LH,8	IDATA+1,1
	SAS,6	-1
	SAS,7	-1
	SAS,8	-1
	AWM,8	S3
	AWM,7	S2
	AWM,6	S1
	LW,6	COUNT
	BDR,6	*+2
	B	*+3
	STW,6	COUNT
	CAL1,9	1
	CAL1,5	D59
	LW,5	S1
	BAL,7	FL0T
	FDS,4	V0LT
	STW,4	8
	LW,5	S2
	BAL,7	FL0T
	FDS,4	V0LT
	STW,4	9
	LW,5	S3
	BAL,7	FL0T
	FDS,4	V0LT
	STW,4	10
	FDS,8	=FS'2000.'
	FDS,9	=FS'2000.'
	FDS,10	=FS'2000.'
	FDS,8	AA
	FDS,9	BB
	FDS,10	CC
	STW,8	A
	STW,9	B
	STW,10	C
	STW,8	7
	BAL,15	CONEB
	STW,12	M2+2
	STW,13	M2+3
	STW,14	M2+4
	STW,9	7
	BAL,15	CONEB
	STW,12	M2+6

DISABLES 59

STW,13 M2+7  
STW,14 M2+8  
STW,10 7  
BAL,15 CUNEB  
STW,12 M2+10  
STW,13 M2+11  
STW,14 M2+12  
CAL1,2 PR1  
CAL1,2 PR6  
CAL1,2 PR2  
CAL1,2 PR6  
CAL1,9 1  
VOLT DATA FS'1638.3'  
PR1 DATA X'01000000'  
GEN,1,26,1,4 1,0,1,0  
DATA PP1  
PP1 TEXTC 'CAL CHANNEL #1 CHANNEL #2 CHANNEL #3'

PR2 DATA X'01000000'  
GEN,1,26,1,4 1,0,1,0  
DATA M2  
M2 TEXTC '

RMS RES 1  
RMS1 RES 1  
RETURN RES 1  
R000 B GDAT

GOBE	LW,7	RETURN	
	B	+7	
STORE	LI,1	1	INDEX FOR GETTING HALFWORDS OF
	LH,6	IDATA,1	ION CHAMBER SIGNAL
	LH,7	IDATA+1	COSINE POT
	LH,8	IDATA+1,1	SIN POT
	LH,10	IDATA+2,1	INLET TEMP
	SAS,6	-1	
	SAS,7	-1	
	SAS,9	-1	
	SAS,10	-1	
	LW,3	N	
	STH,6	D,3	
	STH,7	D+1500,3	
	STH,9	D+3000,3	
	STH,10	D+4500,3	
	MW,7	6	
	MW,9	6	
	ANM,6	CONST	ION CHAMBER
	LW,10	FR	
	LW,5	7	
	BAL,1	FLOT	
	FAS,10	4	
	STW,10	FR	
	LW,10	FI	
	LW,5	9	
	BAL,7	FLOT	
	FAS,10	4	
	STW,10	FI	
	ANM,1	N	NUMBER OF SAMPLES
INII	CAL1,9	1	
	LH,6	IDATA+2	
	BGZ	*+3	
	LI,1	C1	FIRST POINT IS NEGATIVE
	B	*+2	
	LI,1	C2	
	STW,1	RETURN	
C1	CAL1,9	1	LOOKING FOR FIRST POSITIVE CROSS
	LH,6	IDATA+2	
	BGZ	*+2	STILL IN NEGATIVE HALF CYCLE
	CAL1,9	1	NOW IN POSITIVE HALF CYCLE
	LI,1	P1	
	STW,1	RETURN	
	B	STORE	LOOKING FOR NEGATIVE CROSSOVER
C2	LH,6	IDATA+2	
	BGZ	*+4	
	LI,1	N1	NOW IN NEGATIVE HALF CYCLE
	STW,1	RETURN	
	B	STORE	

7	RETURN	
	+7	
1	1	INDEX FOR GETTING HALFWORDS OUT OF TABLE
6	IDATA,1	ION CHAMBER SIGNAL
7	IDATA+1	COSINE POT
9	IDATA+1,1	SIN POT
10	IDATA+2,1	INLET TEMP
6	-1	
7	-1	
9	-1	
10	-1	
3	N	
6	D,3	
7	D+1500,3	
9	D+3000,3	
10	D+4500,3	
7	6	
9	6	
6	CONST	ION CHAMBER
10	FR	
5	7	
7	FLOT	
10	4	
10	FR	
10	FI	
5	9	
7	FLOT	
10	4	
10	FI	
11	N	NUMBER OF SAMPLES
1,9	1	
6	IDATA+2	
	*+3	
1	C1	FIRST POINT IS NEGATIVE
	*+2	
1	C2	
11	RETURN	
1,9	1	
6	IDATA+2	LOOKING FOR FIRST POSITIVE CROSSOVER
	*+2	
1,9	1	STILL IN NEGATIVE HALF CYCLE
1	P1	
1	RETURN	NOW IN POSITIVE HALF CYCLE
	STORE	
6	IDATA+2	LOOKING FOR NEGATIVE CROSSOVER
	*+4	
1	N1	
1	RETURN	NOW IN NEGATIVE HALF CYCLE
	STORE	

N1	CAL1,9	1	STILL IN POSITIVE HALF CYCLE
	LH,6	IDATA+2	CHECKING FOR NEXT POSITIVE CROSSOVER
	BGZ	P1P	
	B	STORE	STILL IN NEGATIVE HALF CYCLE
P1	LH,6	IDATA+2	CHECKING FOR NEGATIVE CROSSOVER
	BGZ	STORE	STILL IN POSITIVE HALF CYCLE
	LW,6	M	
	BDR,6	*+2	DECREMENT HALF CYCLE COUNT
	B	T1	IF ZERO WE'RE FINISHED
	STW,6	M	
	LI,1	N1	
	STW,1	RETURN	NOW IN NEGATIVE HALF CYCLE
	B	STORE	
P1P	LW,6	M	
	BDR,6	*+2	DECREMENT HALF CYCLE COUNT
	B	T1	IF ZERO WE'RE FINISHED
	STW,6	M	
	LI,1	P1	
	STW,1	RETURN	NOW IN POSITIVE HALF CYCLE
	B	STORE	
P1	CAL1,5	D5A	
	LW,5	CONST	
	BAL,7	FL0T	
	FDS,4	V0LT	
	STW,4	CONST	
	LW,5	N	
	BAL,7	FL0T	
	STW,4	AN	
	LW,7	CONST	
	FDS,7	AN	
	STW,7	CONST	
	LI,8	0	
	LI,1	0	
	LW,2	N	
	LH,5	D,1	
	BAL,7	FL0T	
	FDS,4	V0LT	
	FSS,4	CONST	
	FMS,4	4	
	FAS,8	4	
	AI,1	1	
	BDR,2	*-7	
	FDS,8	AN	
	FDS,8	A	
	LW,9	E0	
	FAS,9	CONST	
	FDS,8	9	
	FDS,8	A	
	FDS,8	9	

FMS,8	KK1		
FMS,8	KK1		
STW,8	RMS1		
LW,7	CONST		
FDS,7	A		
STW,7	CONST		
LW,6	E0		
FAS,6	7		
LW,8	FR		
LW,9	FI		
FDS,8	=FS'1.3+2014E+06'	1./(1638.3**2)	* 2.
FDS,9	=FS'1.3+2014E+06'		
FDS,9	6		
FDS,7	6		
FDS,8	A		
FDS,9	A		
FDS,8	AN		
FDS,9	AN		
FDS,8	B		
FDS,9	C		
STW,8	FR	REAL PART	
STW,9	FI	IMAG PART	
XW,8	9		
BAL,6	9ATAN2		
FMS,8	CON2		
FAS,8	KK2		
STW,8	ANG	PHASE	
LW,8	FI		
LW,7	FR		
FMS,7	FR		
FMS,8	FI		
FAS,8	7		
BAL,6	9SQRT		
STW,8	AMP	AMPLITUDE	
LW,6	AM		
FMS,6	CS		
FDS,6	AN		
STW,6	FREQ	FREQUENCY	
LW,8	FR		
LW,9	FI		
LW,10	AMP		
FMS,8	KK1	FR IN 8	
FMS,9	KK1	FI IN 9	
FMS,10	KK1	AMP IN 10	
LW,11	ARS		
LW,12	AIS		
LW,13	AFS		
FAS,11	8		
FAS,12	9		

FAS,13	6
STW,11	ARS
STW,12	AIS
STW,13	AFS
STW,8	FR
STW,9	FI
STW,10	AMP
LW,9	RMS1
LW,8	AMP
FMS,8	AMP
FSS,9	8
FDS,9	8
LAW,8	9
BAL,6	9SQRT
FMS,8	=FS'100'
STW,8	RMS
BAL,7	PRINT
LI,1	119
STB,1	P
CAL1,2	PR4
CAL1,1	8P
LI,3	152
LI,4	A
STH,3	DCB+3
STW,4	DCB+2
CAL1,1	WR
LI,4	-4
LI,2	0
LW,3	N
MI,3	4
STH,1	DCB+3
STW,2	DCB+2
CAL1,1	WR
AI,2	1500
BIR,4	9-3
CAL1,1	CL
B	H1

WRITE

\*  
\* SECOND HARMONIC ANALYSIS  
\*

P0W	RES	3	
H1	LI,1	0	INDEX
	LW,2	N	# OF POINTS
	LI,12	0	REAL
	LI,13	0	IMAG
H2	LI,3	-3	
	LW,6	1	
	LW,8	E0	
	FAS,8	CONST	

H3

LH,5 D,6  
BAL,7 FLOAT  
FDS,4 =FS'1638.3'  
FDS,4 A+3,3  
FDS,4 8  
STW,4 POW+3,3  
AI,6 1500  
BIR,3 H3  
LW,6 =FS'2.1  
FMS,6 POW  
FMS,6 POW+1  
FMS,6 POW+2  
FAS,13 6  
LW,7 =FS'1.1  
LW,6 =FS'2.1  
FMS,6 POW+2  
FMS,6 POW+2  
FSS,7 6  
FMS,7 POW  
FAS,12 7  
AI,1 1  
BDR,2 H2  
FDS,12 AN  
FDS,13 AN  
FMS,12 =FS'2.1  
FMS,13 =FS'2.1  
FMS,12 KK1  
FMS,13 KK1  
STW,12 FR  
STW,13 FI  
LW,8 12  
LW,9 13  
FMS,8 12  
FMS,9 13  
FAS,8 9  
BAL,6 9SQRT  
STW,8 AMP  
LW,8 13  
LW,9 12  
BAL,6 9ATAN2  
FMS,8 CON2  
STW,8 ANG  
BAL,7 PRINT  
LI,1 65  
STB,1 P  
CAL1,2 PR6  
CAL1,2 PR4  
CAL1,2 PR6  
LW,6 NUM

GET DATA  
FLOAT IT  
CONVERT TO VOLTS  
DIVIDE BY GAIN  
DIVIDE BY E0

POW,COS, AND SIN ARE NOW NORM

2 \* P \* COS \* SIN  
IMAG

1 = 2 \* SIN \*\* 2

REAL

BDR,6	*+2
B	*+3
STW,6	NUM
B	AGAIN
CAL1,1	OP
CAL1,1	WEOF
CAL1,1	CL
CAL1,2	PR6
CAL1,2	PR5
CAL1,2	PR6
CAL1,2	PR3
CAL1,2	PR6
LW,8	ARS
LW,9	AIS
LW,10	AFS
FDS,8	=FS'3.1
FDS,9	=FS'3.1
FDS,10	=FS'3.1
STW,8	ARS
STW,9	AIS
STW,10	AFS
STW,10	FREQ
FMS,8	ARS
FMS,9	AIS
FAS,8	9
BAL,6	9SQRT
STW,8	AMP
LW,8	AFS
FMS,8	AFS
LW,6	F0
FMS,6	F0
FDS,8	6
FAS,8	=FS'1.1
BAL,6	9SQRT
LW,7	AMP
FMS,7	8
STW,7	AMP
LW,9	ARS
LW,8	AIS
BAL,6	9ATAN2
STW,8	ANG
LW,9	AFS
LW,8	WC
BAL,6	9ATAN2
LW,7	ANG
FAS,7	8
FMS,7	CON2
FAS,7	KK2
STW,7	ANG

FREQUENCY

AMPLITUDE

PHASE

ANGLE IN DEGREES

FDS,7	C0N2
STW,7	8
BAL,6	9SIN
STW,8	12
STW,7	8
BAL,6	9C0S
STW,8	13
FMS,13	AMP
FMS,12	AMP
STW,12	FI
STW,13	FR
LI,1	119
STB,1	P
BAL,7	PRINT
CAL,1,2	PR4
CAL,1,2	PR6
LW,6	AFS
FMS,6	PI2
STW,6	AA
FMS,6	AA
STW,6	AFS
LW,12	LSTR
LI,13	0
LI,1	-6
LW,8	AA
LW,9	LAM+6,1
BAL,6	9ATAN2
FMS,8	=FS'-1.'
STW,8	14
LW,3	LAM+6,1
FMS,8	8
FAS,8	AFS
BAL,6	9SQRT
STW,8	9
LW,8	BETA+6,1
FDS,8	9
STW,8	15
LW,8	14
BAL,6	9C0S
STW,8	7
LW,8	14
BAL,6	9SIN
FMS,7	15
FMS,8	15
FAS,12	7
FAS,13	8
BIR,1	LP1
STW,12	RT
STW,13	IT

LP1

LW,8 13  
LW,9 12  
BAL,6 9ATAN2  
FAS,8 PI4  
FMS,8 CON2  
FMS,8 =FS'1.1'  
STW,8 GZANG  
FMS,12 12  
FMS,13 13  
FAS,12 13  
LW,8 12  
BAL,6 9SQRT  
FMS,8 AA  
LW,6 =FS'1.1'  
FDS,6 8  
STW,6 GZAMP  
LW,7 GZANG  
BAL,15 CONEB  
STW,12 PP6+9  
STW,13 PP6+10  
STW,14 PP6+11  
LW,7 GZAMP  
BAL,15 CONEB  
STW,12 PP6+2  
STW,13 PP6+3  
STW,14 PP6+4  
CAL1,2 PR6  
CAL1,2 PR8  
CAL1,2 PR6  
LW,6 ANG  
LW,7 GZANG  
FDS,6 CON2  
FDS,7 CON2  
STW,6 ANG  
STW,7 GZANG  
LW,8 INFLAG  
BNEZ LP2  
LI,8 1  
STW,8 INFLAG  
LW,8 GZAMP  
FDS,8 AMP  
STW,8 KK1  
LW,8 GZANG  
FSS,8 ANG  
FMS,8 CON2  
STW,8 KK2  
LW,7 KK2  
BAL,15 CONEB  
STW,12 PP5+12

REAL IN 12, IMAG IN 13

RT  
IT  
PRU

RES 1  
RES 1  
DATA X:01000000  
GEN,1,26,1,4 1,0,1,0  
PP7 DATA

PRR  
PPS

DATA X:01000000  
GEN,1,26,1,4 1,0,1,0  
PP6 DATA  
TEXT '00 AMP =

00 PHASE =

TEXT 'PHASE CONSTANT =

PRV  
PPS

STW,13 PPS+13  
STW,14 PPS+14  
LM,7 KK1  
BAL,15 C0N8B  
STW,12 PPS+4  
STW,13 PPS+5  
STW,14 PPS+6  
CAL,1,2 PR7  
CAL,1,2 PR6  
LP2  
DATA X:01000000  
GEN,1,26,1,4 1,0,1,0  
PP5 DATA  
TEXT 'GAIN CONSTANT =

PP/            TEXT:            'FEEDBACK COMPONENTS'

LP2            LW,4            IT  
                LW,5            RT  
                FMS,4            AA  
                FMS,5            AA  
                FMS,4            =FS'1.1'  
                LW,12            =FS'1.1'  
                FDS,12            AMP  
                LW,7            ANG  
                FMS,7            =FS'1.1'  
                STW,7            8  
                BAL,6            9COS  
                LW,13            12  
                FMS,12            8  
                FSS,12            4  
                STW,12            FR  
                LW,8            7  
                BAL,6            9SIN  
                FMS,13            8  
                FSS,13            5  
                STW,13            FI  
                LW,8            FR  
                FMS,8            FR  
                LW,9            FI  
                FMS,9            FI  
                FAS,8            9  
                BAL,6            9SQRT  
                STW,8            AMP  
                LW,8            FI  
                LW,9            FR  
                BAL,6            9ATAN2  
                FMS,8            CON2  
                STW,8            ANG  
                BAL,7            PRINT  
                LI,1            65  
                STB,1            P  
                CAL1,2            PR10  
                CAL1,2            PR4  
                CAL1,2            PR6  
                CAL1,2            PR6  
                CAL1,9            1

\*  
\*            BAL,7            FL0T  
\*  
FL0T            LW,4            PS

	CI,5	0
	BEZ	*+5
	BGZ	*+2
	LW,4	NEG
	SFL,4	1+
	B	*+2
	LI,4	0
	B	*7
PS	DATA	X'E000000'
NEG	DATA	X'B1FFFFFF'
*		
*	BAL,7	GDATA
*		
NN	DATA	1
IHDL	RES	7
ICUNTR	DATA	0
	DATA	3
IDEV	DATA	12
IWAIT	DATA	0
ILOC	DATA	2
	RES	1
ISTAT	RES	1
IDATA	GEN,4,28	8,0
	RES	2
GDAT	LI,14	6
	BAL,15	MAIN
	DATA	NN
	DATA	IHDL
	DATA	IDEV
	DATA	IWAIT
	DATA	ILOC
	DATA	ISTAT
	CAL,9	1
*		
*	PRINT ROUTINE	
*		
TEMP	RES	1
PRINT	STW,7	TEMP
	LW,7	FR
	BAL,15	CONEB
	STW,12	P+1
	STW,13	P+2
	STW,14	P+3
	LW,7	FI
	BAL,15	CONEB
	STW,12	P+5
	STW,13	P+6
	STW,14	P+7
	LW,7	ANG

INTERRUPT #

BAL,15 CONEB  
STW,12 P+9  
STW,13 P+10  
STW,14 P+11  
LW,7 AMP  
BAL,15 CONEB  
STW,12 P+13  
STW,13 P+14  
STW,14 P+15  
LW,7 FREQ  
BAL,15 CONEB  
STW,12 P+17  
STW,13 P+18  
STW,14 P+19  
LI,2 -4  
LI,3 3  
LW,7 N  
LW,6 =X'FOFOFOFO'  
STW,6 P+21  
LI,6 0  
DW,6 =X'A'  
LB,10 PR9,6  
STB,10 P+21,3  
AI,3 -1  
HIR,2 \*-5  
LW,7 CONST  
BAL,15 CONEB  
STW,12 P+23  
STW,13 P+24  
STW,14 P+25  
LW,7 RMS  
BAL,15 CONEB  
STW,12 P+27  
STW,13 P+28  
STW,14 P+29  
LW,7 TEMP  
B \*7

PR3 DATA X'01000000'  
GEN,1,26,1,4 1,0,1,0

PP2 DATA PP2  
TEXTC ' REAL IMAG PHASE'



```
PR5      DATA      X'01000000'  
          GEN,1,26,1,4 1,0,1,0  
          DATA      PP3  
PP3      TEXTC      'AVERAGES'  
  
PR6      DATA      X'01000000'  
          GEN,1,26,1,4 1,0,1,0  
          DATA      PP4  
PP4      TEXTC      ' '  
PR9      DATA,1     X'F0',X'F1',X'F2',X'F3',X'F4',X'F5',X'F6',X'F7'  
  
          DATA,1     X'F8',X'F9'  
  
BOUND    4  
LSTR     DATA      FS'.110026E-06'  
BETA     DATA      FS'.2329035E-03'  
          DATA      FS'.1406622E-02'  
          DATA      FS'.129913E-02'  
          DATA      FS'.2853856E-02'  
          DATA      FS'.104950E-02'  
          DATA      FS'.2577885E-03'  
LAM      DATA      FS'.0127'  
          DATA      FS'.0317'  
          DATA      FS'.115'  
          DATA      FS'.311'  
          DATA      FS'1.4'  
          DATA      FS'3.87'  
CON2     DATA      FS'57.2958'  
PI2      DATA      FS'6.2831853'  
PI4      DATA      FS'1.5707963'  
OP       GEN,8,24    X'14',DCB  
          DATA      0  
CL       GEN,8,24    X'15',DCB  
          DATA      0  
WR       GEN,8,24    X'11',DCB  
          GEN,10,22   1,X'10'
```

0	RES	6000	ENTER
ERP	TEXT		
	DATA		
	GEN,1,26,1,4	1,0,1,0	
EM	DATA	X:02000000	
	B	WRITE	
ERR	CALL,2	EM	
	GEN,15,17	0,ERR	
	DATA	0	
	GEN,8,9,7,8	4,1,8,10	
DCB	GEN,8,24	5,3	
MEBF	GEN,8,24	X:02,DCB	
	DATA	0	

REFERENCES

1. R. W. Hyndman, M. R. Tuck, and F. S. Kirn, *On-line Transfer Function Analysis of EBR-II*, Trans. Am. Nucl. Soc., 10(2), 696 (November 1967).
2. R. W. Hyndman and M. R. Tuck, *An On-line Method of Transfer Function Analysis in EBR-II*, Nucl. Appl. 6, 137-141 (February 1969).
3. R. W. Hyndman and R. B. Nicholson, *The EBR-II Feedback Function*, ANL-7476 (July 1968).
4. R. R. Smith, et al., *The Effects of an Over-cooled Stainless Steel Reflector on the EBR-II Power Coefficient*, ANL-7544 (May 1969).
5. I. A. Engen, *A New Technique for Investigating Feedback and Stability of a Nuclear Reactor*, ANL-7686 (June 1970).
6. I. A. Engen and R. W. Hyndman, *A Catalog of Rod-drop and Transfer-function Data from EBR-II Runs 25 through 30A*, ANL-7542 (May 1970).
7. J. M. Allen, et al., *Functional Description of the EBR-II Digital Data Acquisition System*, ANL/EBR-029 (November 1970).
8. H. A. Larson, R. W. Hyndman, and I. A. Engen, *On-line Feedback Analysis at EBR-II*, Trans. Am. Nucl. Soc., 14(1), 311 (June 1971).
9. R. O. Brittan, *Some Problems in the Safety of Fast Reactors*, ANL-5577 (May 1956).
10. M. R. Tuck, I. A. Engen, and R. W. Hyndman, *Computer-Aided Experimental Support*, Trans. Am. Nucl. Soc., 14 (Suppl. 2), 34 (August 1971).
11. R. B. Blackman and J. W. Tukey, *The Measurement of Power Spectra*, Dover Publications, Inc., New York (1958).