

2. To: (Receiving Organization) Distribution		3. From: (Originating Organization)		4. Related EDT No.: NA	
5. Proj./Prog./Dept./Div.: TWRS		6. Design Authority/ Design Agent/Cog. Engr.: P. M. Daling		7. Purchase Order No.: NA	
8. Originator Remarks: The Decision Document, Low-Level Waste Feed Staging Strategy, originally issued in May 1996 as an unnumbered report, is now issued as a supporting document.				9. Equip./Component No.: NA	
				10. System/Bldg./Facility: NA	
11. Receiver Remarks: 11A. Design Baseline Document? <input type="checkbox"/> Yes <input checked="" type="checkbox"/> No				12. Major Asm. Dwg. No.: NA	
				13. Permit/Permit Application No.: NA	
				14. Required Response Date: NA	

15. DATA TRANSMITTED					(F)	(G)	(H)	(I)
(A) Item No.	(B) Document/Drawing No.	(C) Sheet No.	(D) Rev. No.	(E) Title or Description of Data Transmitted	Approval Designator	Reason for Transmittal	Originator Disposition	Receiver Disposition
1	WHC-SD-WM-TI-788	-	0	Decision Document, Low-Level Waste Feed Staging Strategy	NA	1, 2	1	1

16. KEY					
Approval Designator (F)		Reason for Transmittal (G)		Disposition (H) & (I)	
E, S, Q, D or N/A (see WHC-CM-3-5, Sec.12.7)		1. Approval	4. Review	1. Approved	4. Reviewed no/comment
		2. Release	5. Post-Review	2. Approved w/comment	5. Reviewed w/comment
		3. Information	6. Dist. (Receipt Acknow. Required)	3. Disapproved w/comment	6. Receipt acknowledged

17. SIGNATURE/DISTRIBUTION (See Approval Designator for required signatures)											
(G) Reason	(H) Disp.	(J) Name	(K) Signature	(L) Date	(M) MSIN	(G) Reason	(H) Disp.	(J) Name	(K) Signature	(L) Date	(M) MSIN
		Design Authority									
		Design Agent									
1	1	Cog. Eng. P. J. Certa	<i>PJ Certa</i>	10/4/96	H5-61						
1	1	Cog. Mgr. R. P. Marshall	<i>RPM</i>	10/4/96	H5-61						
		QA									
		Safety									
		Env.									

18. <i>PJ Certa</i> 10/4/96 P. J. Certa Signature of EDT Originator Date		19. <i>PJ Certa</i> 10/4/96 Authorized Representative Date for Receiving Organization		20. R. P. Marshall 10/4/96 <i>RPM</i> Design Authority/ Cognizant Manager Date		21. DOE APPROVAL (if required) Ctrl. No. <i>na</i> <input type="checkbox"/> Approved <input type="checkbox"/> Approved w/comments <input type="checkbox"/> Disapproved w/comments	
---	--	--	--	--	--	---	--

Decision Document, Low-Level Waste Feed Staging Strategy

P. M. Daling

Prepared for Westinghouse Hanford Company, Richland, WA 99352
U.S. Department of Energy Contract DE-AC06-87RL10930

EDT/ECN: 617632 UC: 2020
Org Code: 73730 Charge Code: D6129
B&R Code: EW3130010 Total Pages: 53

Key Words: Tank Waste Remediation System (TWRS), Phase I, Privatization, Low-Level Waste, Low-Activity Waste, Feed Staging Strategy, Indirect Feed Staging, Intermediate Feed Staging, Double-Shell Tank (DST)

Abstract: This report documents the decision to use the *Indirect Staging- As Soon As Possible* feed staging strategy to deliver supernate feed to the private low-activity waste contractors during Phase I of TWRS Privatization. Two double-shell tanks are needed for intermediate feed staging tanks in addition to the two double-shell tanks that will be turned over to the private contractors as feed tanks.

This report was originally issued on May 7, 1996, by Phil M. Daling of Pacific Northwest National Laboratory as an unnumbered report. It is being released as a supporting document so that others can search for and find this report. Its original citation was: WHC, 1996, *Decision Document, Low-Level Waste Feed Staging Strategy*, May 7, 1996.

TRADEMARK DISCLAIMER. Reference herein to any specific commercial product, process, or service by trade name, trademark, manufacturer, or otherwise, does not necessarily constitute or imply its endorsement, recommendation, or favoring by the United States Government or any agency thereof or its contractors or subcontractors.

Printed in the United States of America. To obtain copies of this document, contact: WHC/BCS Document Control Services, P.O. Box 1970, Mailstop H6-08, Richland WA 99352, Phone (509) 372-2420; Fax (509) 376-4989.

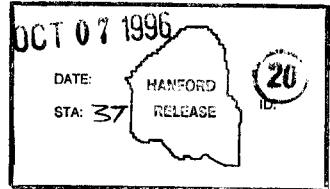

James B. Bishop 10-7-96
Release Approval Date

Release Stamp

Approved for Public Release

WHC-SD-WM-TI-788
Revision 0

**DECISION DOCUMENT,
LOW-LEVEL WASTE
FEED STAGING STRATEGY**

September 1996

P. M. Daling

Prepared for
Westinghouse Hanford Company
Richland, Washington

This page intentionally left blank.

**DECISION DOCUMENT, LOW-LEVEL WASTE
FEED STAGING STRATEGY**

INTRODUCTION AND BACKGROUND

The U.S. Department of Energy is pursuing a strategy referred to as "privatization" to support remediation of Hanford Site tank wastes. This strategy involves hiring private contractors to perform Tank Waste Remediation System (TWRS) functions on a pay-for-product basis. A portion of the wastes stored in double-shell tanks will be processed in Phase I of this strategy to demonstrate the technical, financial, and regulatory viability of the privatization concept. In order to do so, the TWRS program will be required to deliver double-shell tank supernate feed to the privatization contractor(s) in accordance with the feed delivery requirements and specifications contained in the privatization Request for Proposal issued in February 1996 and, subsequently, in the contracts negotiated with the private vendors.

The purpose of this activity is to determine the preferred low-level waste (LLW) feed staging strategy for providing double-shell tank supernate to the privatization contractor(s) to support the Phase I demonstrations. The selected feed staging strategy will form the basis for development of a detailed feed staging plan. The feed staging plan will expand the strategy to provide additional information regarding LLW feed staging, including selection of the feed staging tanks to be used by the Project Hanford Management Contractors, development of a feed staging schedule, recommend any necessary tank farm upgrades, and other information relevant to providing LLW feed that complies with required feed specifications and schedules.

A TWRS Decision Board was convened to evaluate the attributes of various potential LLW feed staging strategies. This report was prepared to document the activities conducted by the Decision Board and the technical staff assigned to explore LLW feed staging alternatives. This assessment was conducted in accordance with TWRS system engineering procedures (see *TWRS System Engineering Manual*, Chapter 7, "Decision Management," WHC-IP-1231).

The original, unnumbered report, *Decision Document, Low-Level Waste Feed Staging Strategy*, is attached as Appendix A.

This page intentionally left blank.

APPENDIX A

**DECISION DOCUMENT, LOW-LEVEL WASTE
FEED STAGING STRATEGY**

This page intentionally left blank.

DECISION DOCUMENT
LOW-LEVEL WASTE FEED STAGING STRATEGY

May 1996

Westinghouse Hanford Company
Richland, Washington

CONTENTS

APPROVALS iii

DECISION PLAN

1.0 Statement of The Decision 1
2.0 Decision Class 1
3.0 Responsibilities 1
4.0 Decision Strategy 2
5.0 Decision Criteria 2
6.0 Required Information 2
7.0 Decision Time Frame 2
8.0 Anticipated Interactions With Other Decisions 2
9.0 External Influences/considerations 2
10.0 Current Planning Basis/assumptions 3

DECISION SUMMARY

1.0 Statement of the Decision 4
2.0 Generation of Alternatives 4
3.0 Screening of Alternatives 4
4.0 Decision Criteria 4
5.0 Analysis of Alternatives 4

RECORD OF DECISION

1.0 Statement of The Decision 5
2.0 Decision Maker 5
3.0 Decision Action Officer 5
4.0 Alternative Selected 5
5.0 Date of Selection 5
6.0 Decision Criteria 5
7.0 Rationale For The Selection 6
8.0 External Assumptions 7
9.0 Alternatives Considered 7
10.0 References 8

ATTACHMENT 1 DECISION BOARD MEETING MINUTES

March 26, 1996 Meeting Minutes 10
April 9, 1996 Meeting Minutes 16

APPROVALS



John E. Truax, Chairman, Decision Board

5/7/96

Date



Gary A. Meyer, Member, Decision Board

5/7/96

Date

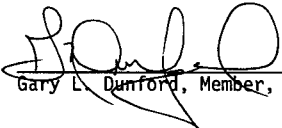

Gary L. Dunford, Member, Decision Board

5/7/96

Date



James D. Thomson, Member, Decision Board

5/7/96

Date

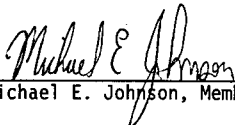

Michael E. Johnson, Member, Decision Board

5/7/96

Date

DECISION PLAN

LOW LEVEL WASTE FEED STAGING STRATEGY

1.0 STATEMENT OF THE DECISION

What is the preferred method for providing low-level waste (LLW) feed to the privatization contractors? The preliminary LLW feed staging plan identified three options:

- *Direct Staging* to privatization contractors' tanks.
- *Indirect Staging When Notified* to privatization contractors' tanks.
- *Indirect Staging As Soon As Possible* to privatization contractors' tanks.

2.0 DECISION CLASS

Decision Class: Class III

3.0 RESPONSIBILITIES

3.1 Decision Maker

J. E. Truax, Deputy Director, Tank Farm Transition Projects
J. O. Honeyman, Director, Disposal Programs

3.2 Decision Action Officer

D. J. Washenfelder, Manager, Disposal Engineering

3.3 Decision Support Board

The Decision Support Board will have the following representatives:

- J. E. Truax (Chairman), Tank Farm Transition Projects
- G. A. Meyer, Retrieval Program
- G. L. Dunford, TWRS Safety Project
- J. D. Thomson, Technical Integration
- M. E. Johnson, Process Technology

Personnel from the Disposal Engineering organization will provide technical expertise to the Decision Support Board.

4.0 DECISION STRATEGY

The decision provides an initial planning case for the confirmation of the current LLW feed staging analysis. The current analysis shows significant benefits for indirect staging of LLW to the privatization contractors' tanks. In addition, a preliminary Operational Waste Volume Projection (OWVP) shows the current tank space can support all three LLW feed staging alternatives.

5.0 DECISION CRITERIA

The decision will be based upon cost, schedule, and flexibility (including minimizing M&I contractor liability relative to providing feed to the private LLW vitrification contractor).

6.0 REQUIRED INFORMATION

1. Revision 22 of the *Operational Waste Volume Projection* (Draft in progress).
2. *Preliminary Low-Level Waste Feed Staging Plan*, WHC-SD-WM-RPT-210, Rev. 0 (Certa et al. 1996).

7.0 DECISION TIME FRAME

The LLW feed staging confirmation study requires a decision by March 29, 1996 to allow the analysis of feed staging to occur without unnecessary re-evaluation of LLW feed compositions in the feed staging plan. The LLW feed staging plan must be reissued in August 1996 to support issuance of the Phase 1A TWRS privatization contracts.

8.0 ANTICIPATED INTERACTIONS WITH OTHER DECISIONS

The HLW feed staging decision and other decisions within operation of the tank farms (e.g., jumper versus manifolds).

9.0 EXTERNAL INFLUENCES/CONSIDERATIONS

The external considerations for this decision include contractual arrangements between the DOE and privatization contractors and the sampling strategy and specifications for feed to the vendor.

10.0 CURRENT PLANNING BASIS/ASSUMPTIONS

The current planning assumes the direct feeding to the privatization contractors' feed tanks.

DECISION SUMMARY

1.0 Statement of Decision

What is the preferred method for providing LLW feed to the privatization contractors?

2.0 Generation of Alternatives

The preliminary LLW feed staging plan, WHC-SD-WM-RPT-210, Rev. 0, identified three options:

- *Direct Staging* to privatization contractors' tanks.
- *Indirect Staging When Notified* to privatization contractors' tanks.
- *Indirect Staging As Soon As Possible* to privatization contractors' tanks.

3.0 Screening of Alternatives

All three alternatives listed above are technically viable. Therefore, all three were examined in detail in the preliminary feed staging study. The preliminary study evaluated each of these alternatives relative to a set of criteria and developed a recommended alternative. The results of this study were summarized and presented to a Decision Support Board which made the final decision.

4.0 Decision Criteria

The decision will be based upon cost, schedule, and flexibility (including minimizing M&I contractor liability relative to providing feed to the private LLW vitrification contractor).

5.0 Analysis of Alternatives

The analysis of alternatives is documented in WHC-SD-WM-RPT-210, Rev. 0. A summary of the information in the document, including updated and improved results incorporating recent revisions to the Phase I privatization RFP, was presented to the Decision Board (see attached meeting minutes) on March 26, 1996.

RECORD OF DECISION

1.0 STATEMENT OF THE DECISION

What is the preferred method for providing LLW feed to the privatization contractors?

2.0 DECISION MAKER

J. E. Truax, Deputy Director, Tank Farm Transition Projects
J. O. Honeyman, Director, Disposal Programs

3.0 DECISION ACTION OFFICER

D. J. Washenfelder, Manager, Disposal Engineering

4.0 ALTERNATIVE SELECTED

The Decision Board selected the alternative referred to in the *Preliminary Low-Level Waste Feed Staging Plan*, (Rev 0) as *Indirect Staging As Soon As Possible (ASAP)*. In this alternative, DST supernate would be transferred to an intermediate DST for staging before the waste is transferred to the private contractors' feed tanks (i.e., AP-106/AP-108). The staging process in the intermediate tanks for each batch would begin as soon as possible after the previous batch of feed has been transferred to the private contractor feed tank.

5.0 DATE OF SELECTION

The decision to pursue the *Indirect Staging ASAP* strategy was made at a Decision Board meeting held on March 26, 1996. The signature page at the beginning of this document includes the date this document was approved by the Decision Board.

6.0 DECISION CRITERIA

1. **Cost.** Qualitative assessment of tank modification costs necessary to support the alternative strategies.
2. **Schedule.** This was measured by calculating the probability of successful LLW feed staging events and median length of feed outage (time the private contractors are waiting for feed from the M&I contractor).

3. **Flexibility.** This was measured in terms of the median time available for contingencies. This addressed processing flexibility but also is a measure of the potential liability of the M&I contractor in the event that LLW feed is not available when required by the private contractor(s). It is a proxy measure for the amount of time available to recover from a batch of waste that is determined to not meet the feed specifications or were delayed for some other reason.

7.0 RATIONALE FOR THE SELECTION

1. **Cost:** A qualitative cost assessment indicated that *Indirect Feed Staging* strategy has lower costs than *Direct Feed Staging*. This is primarily due to the projected requirement to modify all of the feed tanks to support direct feed staging but only having to modify the two specified intermediate tanks for indirect feed staging. Therefore, *Indirect Feed Staging ASAP* and *Indirect Feed Staging When Notified*, would be favored over *Direct Staging* from the perspective of tank modification costs.
2. **Schedule:** Simulation modeling was performed to determine the feed staging alternative that best supports the timing requirements in the Privatization Request for Proposals (RFP). It was determined that *Indirect Feed Staging ASAP* is the most likely strategy to provide feed to the privatization contractor within the 30 or 60 day feed delivery window. *Direct Feed Staging* was the least likely strategy to provide feed within the required delivery window. Similarly, the median feed outage days are lowest for the *Indirect Feed Staging ASAP* alternative and highest for the *Direct Feed Staging* alternative. Both performance measures suggest that *Indirect Feed Staging ASAP* is favored over the other alternatives.
3. **Contingency:** As with the schedule performance, simulation modeling was performed to estimate the amount of contingency time available. Higher contingency times are favored as they would allow the M&I contractor time to recover from out-of-specification feed, sampling/analytical delays, etc. Since the M&I contractor could be held liable for delays in the private contractors' processing campaigns, it is highly desirable from the M&I contractor's perspective to build in a large contingency time to ensure that time is available to recover from delays. The analysis showed that the *Indirect Feed Staging ASAP* alternative resulted in the largest contingency times and direct feed staging resulted in the lowest contingency time. Therefore, *Indirect Feed Staging ASAP* would be favored from this perspective.

8.0 EXTERNAL ASSUMPTIONS

There were two key assumptions that can have significant impacts on this decision, including Operational Waste Volume Projections (OWVPs) and the feed requirements in the final RFP. These two items are addressed below.

- **Operational Waste Volume Projections (OWVPs)** are generated periodically to assist in planning for future waste management activities. The OWVPs include, among other things, assessments of the current waste storage capacities, current waste volumes, and projections of future needs for tank space. A special waste volume project was performed to determine the DST space available for SST retrieval as a function of time. It was determined that there will be sufficient DST space to support feed staging activities if SST retrieval is planned to fit within the remaining DST space over time.
- **The Privatization RFP** was issued to potential vendors in February 1996. The engineering study evaluated the feed staging alternatives using the January 1996 draft RFP as the basis for many parameters used in the performance evaluations, including the feed delivery window (60 days), feed requirements (MT of Na), and preliminary feed specifications. The revisions to the RFP are known at this time and the analysts had updated their study to account for known changes (such as change from a 60 day feed delivery window to a 30 day window). None of the changes affected the conclusion that *Indirect Feed Staging ASAP* is the best alternative.

9.0 ALTERNATIVES CONSIDERED

Two other alternative LLW feed staging strategies were examined; *Direct Feed Staging* and *Indirect Feed Staging When Notified*. These alternatives are described below:

- *Direct Feed Staging* refers to the alternative in which all transfers, dilutions, mixing, and sampling takes place in the private contractors' feed tanks. In this alternative, transfers from the M&I contractor's tanks cannot begin until the previous batch of supernate in the private contractors' tanks has been removed for processing. The analysis of this alternative indicated it would likely cost more, results in lower contingency time to accommodate delays or rework an out-of-specification batch of supernate, and is less likely to provide feed within the delivery window specified in the RFP than the other alternatives.
- *Indirect Feed Staging When Notified* is similar to the *Indirect Feed Staging ASAP* alternative in that intermediate tanks would be used to

stage feed prior to its transfer to the private contractors' tanks. The main difference is that, in the *When-Notified* alternative, transfers to the intermediate tanks begin when notification is received from the private M&I contractors whereas in the *ASAP* alternative, transfers begin immediately after the intermediate staging tanks are emptied. In both alternatives, transfers into the private contractors' tanks cannot begin until previous batch has been processed. The *Indirect Feed Staging When Notified* alternative would cost about the same as the *Indirect Feed Staging ASAP* alternative (lower than *Direct Feed Staging*), and were ranked between *Direct Feed Staging* and *Indirect Feed Staging ASAP* for the other performance measures (i.e., less desirable than *Indirect Feed Staging ASAP* but more desirable than *Direct Feed Staging*).

10.0 REFERENCES

Certa, P.J., C.M. McConville, L.W. Shelton, and E.J. Slaathaug. 1996. *Preliminary Low-Level Waste Feed Staging Plan*. WHC-SD-WM-RPT-210, Rev. 0. Westinghouse Hanford Co., Richland, Washington.

ATTACHMENT
DECISION BOARD MEETING MINUTES

MEETING MINUTES			
SUBJECT: LLW Feed Staging Decision Board Meeting			
TO: Distribution		BUILDING: 2440 Stevens / 2200	
FROM: John Truax / Phil Daling		CHAIRMAN: John Truax	
DEPARTMENT-OPERATION-COMPONENT: TWRS	AREA: RCHN	DATE OF MEETING: March 26, 1996	NUMBER ATTENDING: 13
ATTENDEES			
Bill Awadalla	Decision Management Team, WHC		
Kayle Boomer	Disposal Program, TWRS		
Paul Certa	Disposal Program, TWRS		
Phil Daling	Decision Management Team, PNNL		
Gary Dunford	Member, Decision Board, TWRS		
Mike Johnson	Member, Decision Board, TWRS		
Dave Seaver	Decision Management Team, PNNL		
Jim Thomson	Member, Decision Board, TWRS		
John Truax	Chairman, Decision Board, TWRS		
Hal Wacek	DOE-RL		
Dennis Washenfelder	Member, Decision Board, TWRS		
BACKGROUND			
<p>This was the first meeting of a Decision Support Board convened to select a preferred strategy for staging feed for transfer to a private contractor for processing (vitrification). A decision needs to be made at this time to allow the analysis of feed staging to occur without unnecessary re-evaluation of the LLW feed process envelopes. The purpose of this meeting was for the Board to obtain information on the framework for this decision (reason why a decision is needed, results of previous studies, description of current planning assumptions), description of alternative strategies, performance of the alternatives, interactions with other decisions, and external constraints. This information was presented to the Board by Dennis Washenfelder and Kayle Boomer in addition to Paul Certa (all WHC) the lead author of a recently completed <i>Preliminary Low-Level Waste Feed Staging Plan</i> (WHC-SD-WM-RPT-210, Rev.0). This document, which is an update and improvement over the feed staging feasibility study submitted to DOE in November 1995, evaluated the performance of three alternative LLW feed staging strategies and forms the technical basis for the decision. The preliminary feed staging plan supports the Phase I privatization effort by providing recommendations that may influence the technical content of the</p>			

MEETING MINUTES (Continued)

Page 2 of 6

final privatization request for proposals (RFP). The document may also influence the interface control documents for the turnover of two double-shell tanks to the private contractors to be used as feed tanks and the transfer of supernate from the Hanford M&I contractor to the private contractors. A final feed staging plan is due in August, 1996.

AGENDA

1. Convene at 4:00 PM on March 26, 1996.
2. Decision Framework and purpose of the meeting (DJW).
3. Study overview and conclusions (PJC)
4. Operational considerations, waste volume projections, and comparison of alternatives (KDB)
5. Adjourn.

SUMMARY

A Decision Support was convened to select a preferred strategy for providing feed to the low-level waste vitrification vendor. The results and conclusions of a preliminary feed staging plan (WHC-SD-WM-RPT-210, Rev. 0) were presented to the Board for consideration and discussion. The Board concluded that the preferred strategy would be **Indirect Feed Staging As Soon as Possible** and assigned staff to document the decision.

DISCUSSION

The issue addressed by this Decision Board is how best to stage feed for transferring supernate to the private contractors' feed tanks. Two feed tanks are required, one for each contractor in Phase I of the privatization effort. A preliminary feed staging plan was issued in February (WHC-SD-WM-RPT-210, Rev. 0) which was based on assumptions in the draft privatization request for proposals (RFP) issued in late January. Since that time, the study authors are updating and improving the analysis, including incorporating changes made in the final RFP, such as a change from a 60 day to 30 day feed delivery window and some changes in the feed specifications. The main topic of this meeting was for the Board to hear a summary of the information in preliminary study as well as the results of the updates and improvements made since the study was issued.

MEETING MINUTES (Continued)

Page 3 of 6

Three feed staging strategy alternatives have been evaluated, including *Direct Staging*, *Intermediate Staging As Soon As Possible*, and *Intermediate Staging When Notified*. In *Direct Staging*, feed is transferred directly from the M&I contractors' tanks to the private contractors' tanks. All mixing, dilutions, sampling, and transfers take place in the private contractors' tanks. In the *Indirect Staging* strategies, waste is transferred to intermediate staging tanks blending, dilution, mixing, and sampling before the supernate is decanted/transferred to the private contractors' tanks. The staging process could begin either *As Soon As Possible* (immediately after the previous feed batch is transferred from the intermediate staging tanks to the private contractors' feed tanks) or *When Notified* (waste transfers begin after notification is received from the private contractors). The Decision Board was requested to choose among these strategies or develop another alternative.

The preliminary feed staging study evaluated the performance of the three strategies in terms of their costs, impacts on schedules, and contingency time. A summary of the results is as follows:

1. **Cost:** A qualitative cost assessment indicated that *Indirect Feed Staging* strategy has lower costs than *Direct Feed Staging* due to the projected requirement to modify all of the feed tanks to support *Direct Feed Staging* but only having to modify the two specified intermediate tanks for *Indirect Feed Staging*.
2. **Schedule:** Simulation modeling was performed to determine the feed staging alternative that best supports the timing requirements in the Privatization Request for Proposals (RFP). It was determined that *Indirect Feed Staging ASAP* is the most likely strategy to provide feed to the privatization contractor within the 30 or 60 day feed delivery window.
3. **Contingency:** As with the schedule performance, simulation modeling was performed to estimate the amount of contingency time available. Higher contingency times are favored as they would allow the M&I contractor time to recover from out-of-specification feed, sampling/analytical delays, etc., thus minimizing M&I contractor liability for delays in the private vitrification contractors' processing campaigns. It was determined that *Indirect Feed Staging ASAP* resulted in the largest contingency time and *Direct Feed Staging* exhibited the lowest contingency time.

MEETING MINUTES (Continued)

Page 4 of 6

Based on these results, Indirect Feed Staging ASAP was the preferred alternative recommended by the study authors.

The Decision Board discussed the study results and conclusions with the authors. The key items of discussion are summarized below:

- *Direct Feed Staging* was indicated to be difficult due to the 60 day feed delivery window specified in the draft RFP. This allows insufficient time remove and analyze tank samples in addition to the mixing time, transfer time, etc. It also would not allow contingency time to recover from sampling delays, an out-of-specification feed batch, etc. In addition, the final RFP reduced the LLW feed delivery window to 30 days.
- *Indirect Feed Staging* allows time for decant transfers to the privatization contractors' tanks. The RFP provides a 5 vol% limit on solids transferred to the private contractors which are to be returned to the M&I contractor. Decants would minimize the amount of solids carried over in the transfers and thus would be the most favorable transfer method.
- The method to be used by the private contractor to qualify the LLW form was discussed. This could affect the feed staging process as the qualification method(s) are likely to impose some requirements on feed characteristics. This leads to the conclusion that the alternative that allows the most contingency time would be favored in this respect because it would allow the most time for sampling, analysis, and adjusting the supernate to meet the private contractors' feed specifications.
- Feed staging will affect Operational Waste Volume Projections (OWVPs) by removing certain tanks from consideration for other uses for a period of time. The key question was whether or not the current OWVPs considered that the feed tanks are unavailable during the time they are staging feed. It was indicated that the OWVPs do consider the unavailability of the feed tanks and that there was no need to commit spare tankage to this action. In addition, a question was raised regarding whether other projects, activities, etc., have plans to use the tanks proposed to be used to stage feed (AP-102 and AP-104 for intermediate staging tanks and AP-106 and AP-108 for the private contractors' feed tanks). No other uses for these tanks were identified at the meeting but a more comprehensive search would be

MEETING MINUTES (Continued)

Page 5 of 6

performed to ensure these tanks would be available. This will be included in the Final Feed Staging Study, due in August 1996. It was not important to the present decision.

- It was indicated that feed staging would not have a large effect on tank space unless significant dilution is required to meet the private contractor's feed specifications. At this time, large waste volume increases due to dilution requirements are not expected. The feed specifications in the final RFP do not require dilution of LLW. However, this needs to be revisited if retrieval and transfer of wastes requires significant dilution.
- The first tank space "pinch-point" in the OWVP occurs in the 1998 to 2000 time frame. After that time, the DST system would be near maximum capacity and there would be minimal room available to transfer supernate and accomplish staging. Therefore, there is a desire to begin feed staging as soon as possible to ensure the feed requirements are achievable from an operational perspective. The current goal of accelerating the interim stabilization schedule by one year would move up the "pinch-point" accordingly, resulting in a more urgent need to begin feed staging.
- *Indirect Feed Staging* was also indicated to be favored because it would allow any precipitated solids to be decanted before transfer to the private contractors' feed tanks.
- The Board concluded that feed staging requirements would not, by themselves, affect the decision not to build additional tanks.

AGREEMENTS AND ACTION ITEMS

Agreements

The Decision Board members agreed that *Indirect Feed Staging ASAP* is the preferred LLW feed staging option. This decision does not affect the waste volume projections and does not result in the need for additional double-shell tank space. *Indirect Feed Staging ASAP* was shown to be the lowest cost alternative, results in the highest probability of successfully providing feed, and highest contingency times. The *Indirect Feed Staging* alternatives reduce programmatic risks and reduce M&I contractor liability relative to *Direct Feed Staging*.

MEETING MINUTES (Continued)

Page 6 of 6

Action Items

1. PM Daling to prepare a summary of the decision.

ATTACHMENTS (to these meeting minutes)

1. Paul Certa presentation materials.
2. Kayle Boomer presentation materials.

P.J. Certa

Low-Level Waste Feed Staging Plan

Deliver to the private contractors the appropriate quantities of feed of a specified composition at the proper times.

- Feasibility Study
- Preliminary Plan
- Plan

Scope of Preliminary Plan

- Projecting Waste Inventories
- Assess Feed Envelope Viability
- ● Recommend a Feed Staging Strategy
- Prepare an Operational Scenario
- Identify Issues

Requirements

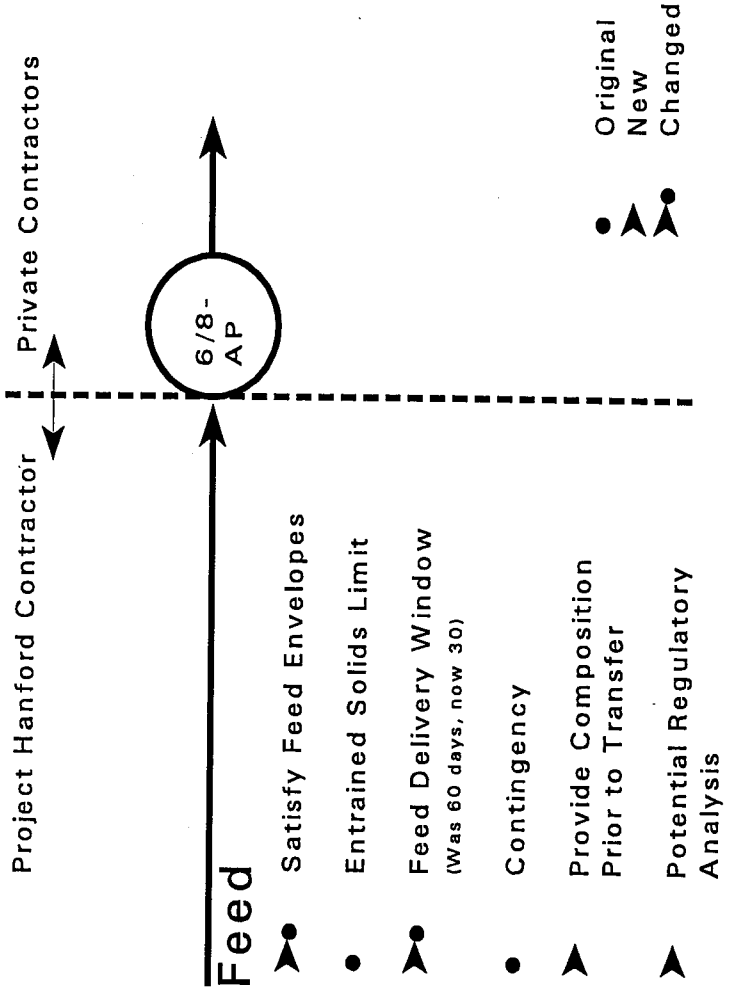

Feed Staging Alternatives

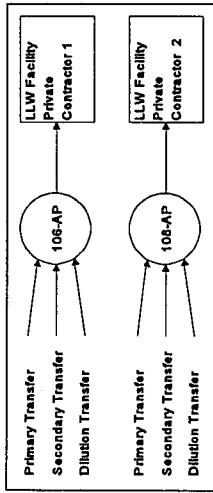

Direct Staging

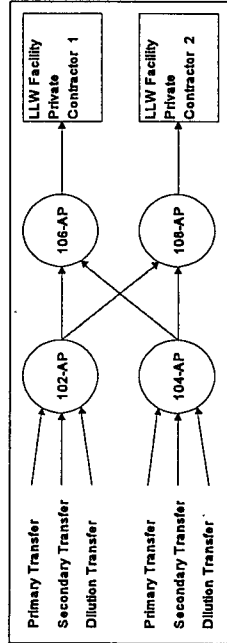

Indirect Staging (both When Notified and ASAP)

Analysis Performed

- **Measures:** Outage, Contingency, Feed Availability, Successful Cases
- **Main Variables:** Transfer Setup and Durations, Dilution Water, Mixing, Sampling, Analysis, Evaluation, Solids Settling, Batch Size
- **Methodology:** Spreadsheet model, Sensitivity Studies, Parametric Studies
- **Results (KDB will discuss)**
- **Conclusions**

Conclusions

- Indirect Staging - ASAP is recommended alternative
- Consistently meeting timing requirements and provides sufficient contingency
- Robust with respect to sensitivity studies
- Parametric Studies suggest:
 - Short Campaigns should be avoided
 - Sensitive to final transfer setup time

WHC-SD-WM-TI-788
Revision 0

NOT TO SCALE
Horizontal axis is time.

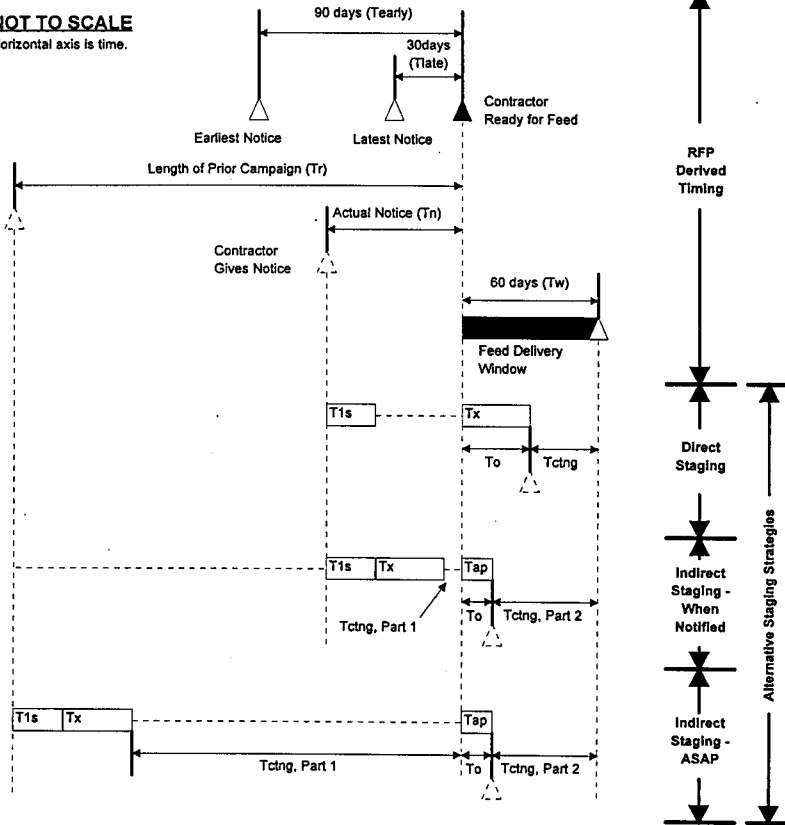

KEY:

- ▲ Time reference & RFP derived milestone.
- △ Other RFP derived milestones.
- △ Calculated Event.
- Activity.
- Dependencies (finish to start)
- ⋮ Dependencies (earliest start or latest finish dates)

VARIABLE:

- Tearly Earliest notice required of Contractor.
- Tlate Latest notice required of Contractor.
- Tn Actual notice given by Contractor.
- T1s Primary transfer setup time.
- Tx Aggregate duration of events from primary transfer to evaluate sample results.
- To Length of outage (feed not available).
- Tctng Available contingency (to correct out-of-spec feed, etc)
- Tap Duration of inter-AP farm transfers (setup and pumping).
- Tw Feed Delivery Window.

K-D. Boomer

Low Level Waste Feed Staging Strategy

March 26, 1996

Operational Considerations

**Upgrade DSTs to provide uniform feed to the vendors
Staging directly in to vendor tank require too much time
(> 30 days)
Fall back strategy necessary when feed shimming
needed**

Operational Waste Volume Projection

- Deterministic evaluation**
- Sensitivity study**

Infrastructure changes the same for all cases

Feed envelopes are established in contract

**Order and sequencing already fixed so U.S. DOE knows
what feed to prepare when**

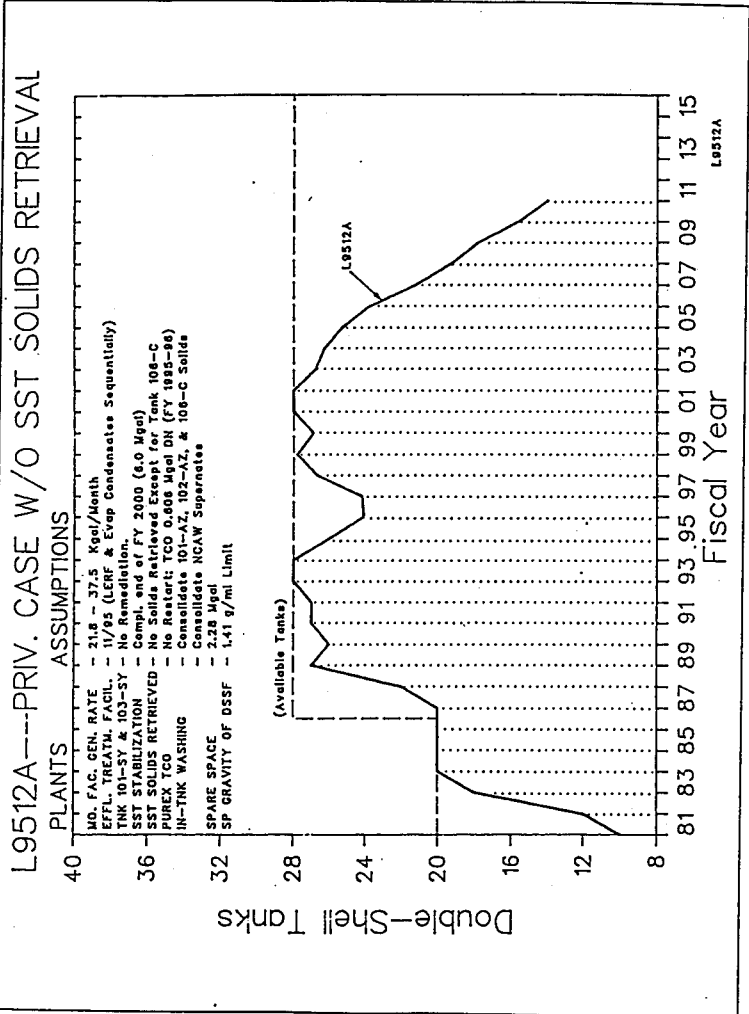

Figure 2-9 - Operational Waste Volume Projection Case L9512A

Waste Volume Sensitivity Study

Variable	Range in Assessment	Comment
Pretreatment Rate	50 to 150 <i>IPM #'s</i>	Needs revision for new strategy
East Single Shell Tank Solids	80 to 120	Volume not determining variable composition of salt cake and sludge drives volume projections.
MUST Volume	500,000 to 10,000,000 gallons	No concentration occurs
Complex Waste Reduction Factor	.25 to .55	Based on engineering judgement

Comparison of Alternatives

Strategy	Timing	Sampling	Contingency	Cost	Waste Volume
Requirement	30 Days	M&I Responsibility	Time between Batches	Modification of Feed Tanks	Stay within Current Space
Direct	Possible	Worst	Worst	Modify All Feed Tanks	Same as OWVP
Indirect When Ordered	Better	Better	Better	Modify Two Tanks	Increase over OWVP by 1st Batch Dilution
Indirect as soon as possible	Best	Best	Best	Modify Two Tanks	Increase over OWVP by 1st Batch Dilution

MEETING MINUTES			
SUBJECT: LLW Feed Staging Decision Board Meeting			
TO: Distribution		BUILDING: 2440 Stevens / 2200	
FROM: John Truax / Phil Daling		CHAIRMAN: John Truax	
DEPARTMENT-OPERATION-COMPONENT: TWRS	AREA: RCHN	DATE OF MEETING: April 9, 1996	NUMBER ATTENDING: 16
ATTENDEES			
Bill Awadalla	Decision Management Team, WHC		
Phil Bartley	Foster-Wheeler		
Kayle Boomer	TWRS, WHC		
Paul Certa	TWRS, WHC		
Gary DukeLow	TWRS, WHC		
Phil Daling	Decision Management Team, PNNL		
Ken Gasper	Member, Decision Board (C-103), TWRS		
Mike Johnson	Member, Decision Board, TWRS		
Nick Kirch	Member, Decision Board, Process Engineering		
Mike Klem	TWRS, WHC		
Dave Seaver	Decision Management Team, PNNL		
Steve Sontag	LATA		
Jim Thomson	Member, Decision Board, TWRS		
John Truax	Chairman, Decision Board, TWRS		
Dave Turner	TWRS, WHC		
Hal Wacek	DOE-RL		
BACKGROUND			
<p>This was the second meeting of the LLW Feed Staging Decision Board. The Decision Board was convened to select a preferred strategy for providing feed to the low-level waste vitrification vendor. The results and conclusions of a preliminary feed staging plan (WHC-SD-WM-RPT-210, Rev. 0) were presented to the Board for consideration and discussion. The Board concluded that the preferred strategy would be Indirect Feed Staging As Soon as Possible and assigned staff to document the decision.</p>			

MEETING MINUTES (Continued)

Page 2 of 3

The purpose of the second meeting was to discuss some important enabling assumptions to allow the Feed Staging Study to continue, primarily the approach to be taken to determine which DSTs should be used as the intermediate LLW feed staging tanks. Paul Certa briefed the Decision Board and his presentation materials are attached. The discussion is summarized in the following sections.

AGENDA

1. Presentation on LLW Feed Staging Decision (Paul Certa).
2. Presentation on C-103 Stabilization decision (this was unrelated to the LLW Feed Staging meeting and is summarized elsewhere).

SUMMARY

The main topic of the meeting was a discussion regarding allocation of DSTs for use as intermediate LLW feed staging tanks. Paul Certa, WHC, briefed the Decision Board on the strategy being taken by the analysts to determine which tanks would be most favorable. Basically, the Board agreed with the approach taken by the analysts to designate the intermediate feed staging tanks. The Board also requested status reports every six weeks from now until the August deliverable is complete.

DISCUSSION

The feedback provided by the Board on the proposed tank allocation strategy are summarized below:

- The DST allocation to feed staging has significant implications on tank upgrades. For example, Project W-314 does not currently include in its scope the necessary upgrades to support feed staging, specifically the required transfer system.
- The Board indicated that the analysts should not ignore options that involve tanks on the Watch List. The general feeling was that the analysts should limit their assessment to technical issues. Watch List issues are in the process of being resolved and should not be a major decision criterion for tank allocation.

MEETING MINUTES (Continued)

Page 3 of 3

- DST AW-104 was briefly mentioned. It was indicated this tank would not be favorable because it contains zeolite from the Evaporator and would be extremely difficult to clean out. In addition, the general feeling was that we would like to avoid tanks containing Neutralized Cladding Removal Waste (NCRW) and double-shell slurry (DSS).
- The analysts will need to consider installation of independent transfer routes if HLW and LLW feed schedules conflict.
- The consensus of those at the meeting was that it did not make sense to stage in 200 West Area. This eliminates SY Farm from consideration. SY Farm was also not favored on the basis that we would have to resolve safety issues in order to use the tanks.
- The Decision Board indicated they would need information on how LLW feed staging integrates with the Operational Waste Volume Projection (OWVP) and Retrieval Sequence studies.
- Paul Certa indicated that the report he is preparing is due August 15.

AGREEMENTS AND ACTION ITEMS

The Decision Board basically agreed with the approach being taken to allocate tanks for use as intermediate LLW feed staging tanks. They directed that documentation of the decision to proceed with the LLW feed staging strategy referred to as *Intermediate Feed Staging - As Soon as Possible* in the Preliminary LLW Feed Staging Plan and continue with the tank allocation effort. The Board requested updates/status reports on 6 to 8 week intervals.

ATTACHMENTS (to these meeting minutes)

1. Paul Certa presentation materials.

Tank Allocation for Intermediate LLW Staging Tanks

Level of Decision Board Involvement?

Decision Strategy?

Decision Statement

Which two DSTs should be allocated for use as intermediate LLW feed staging tanks?

Interacting Decisions

What transfer route upgrades are needed to support LLW Feed Staging, HLW Feed Staging, 242-A Evaporator Operation and other Tank Farm Operations?

Requirements Summary

- Mix, sample and adjust.
- Transfer waste with and without decanting.
- Transfer out-of-specification waste; clean out of problematic solids buildup.
- Deliver approved staged feed within 30 days of the waste transfer date.

NOTIFICATION

Potential Measures

- Cost of upgrading DSTs and Transfer System
- Upgrades available in time for first feed batches
- Complications due to existing tank contents
- Potential for transfer conflicts
- Feed delivery timing
 - Model a transfer system that shares a common route for LLW Feed Staging and HLW Feed Staging.
 - If timing not acceptable, may need to consider benefit of separate routes versus additional cost.

Potential Alternatives

- AN Farm: 101, 106
- AW Farm: 104
- AP Farm: 101, 102, 103, 104, 105, 107
- AY Farm: none
- AZ Farm: none
- SY Farm: none

Decision Strategy?

- No decision board involvement
- Limit alternatives to AP-Farm?
- Technical Work - Decision - Issue Staging Plan
- Technical Work - Recommendation - Issue Staging Plan - Decision
- Other

Preliminary Requirements

- Water dilution capabilities and chemical addition capabilities.
- Mix and sample waste (multiple samples via multiple risers and depths).
- Transfer the supernate and solids (if the solids content and composition is acceptable) to the private contractors' feed tanks.
- Decant and transfer the supernate to the private contractors' feed tanks leaving all or some of the settled solids behind.

- Transfer the entire tank's contents, excluding the heel, if the waste is out-of-spec and must be moved out of the way for later disposition.
- Remove solids that are a problem because of either their quantity or their composition.
- Minimize waste transfer distance to the private contractors' feed tanks. This will reduce the volume of flush water after each transfer.
- Minimize costs for modifications to intermediate feed tanks and associated transfer systems.

- Tanks selected should not interfere with the staging of waste for the 242-A Evaporator, HLW Vitrification Feed Staging or SST stabilization activities.
- Tanks selected should minimize waste transfer route setup times (number of process pits in the route and required setup actions).
- Minimize waste transfer bottle-necks (common piping sections in process pits serving many transfers).

AN Tank Farm

Tank	Waste Type	Supernate Volume (Kgal)	Sludge Volume (Kgal)	Use and/or Status
101	DN	1080	0	DRCVR
102	CC	993	89	CWHT
103*	DSS	18	937 (DSS)	CWHT
104*	DSSF	796	264	CWHT
105*	DSSF	1128	0	CWHT
106	DSSF	400	17	CWHT
107	CC	923	134	CWHT

AW Tank Farm

Tank	Waste Type	Supernate Volume (Kgal)	Sludge Volume (Kgal)	Use and/or Status
101 *	DSSF	1043	84	CWHT
102	DN	94	1	EVFD
103	DN/PD	151	363	DRCVR
104	DN	834	179	DRCVR
105	DN/PD	76	297	DRCVR
106	DN	241	211	SRCVR

AP Tank Farm

Tank	Waste Type	Supernate Volume (Kgal)	Sludge Volume (Kgal)	Use and/or Status
101	DSSF	737	0	DRCVR
102	CP	1098	0	GRTFD
103	DN	25	0	DRCVR
104	DN	834	0	GRTFD
105	DSSF	154	0	CWHT
106	DN	107	0	DRCVR
107	DN	25	0	DRCVR
108	DN	28	0	DRCVR

NOTES

* Tank is on the Watch List

Tank Type

CWHT Concentrated Waste Holding Tank
DRCVR Dilute Receiver Tank
EVFD Evaporator Feed Tank
SRCVR Slurry Receiver Tank
GRTFD Grout Receiver Tank Feed

Waste Type

CC Complexant Concentrate Waste
CP Concentrated Phosphate Waste
DN Dilute Non-Complexed Waste
DSS Double Shell Slurry
DSSF Double Shell Slurry Feed
PD Purex Neutralized Cladding Removal Waste

Tank status Information was obtained from WHC-EP-0182-93/Waste Tank Summary Report for the Month Ending December 31, 1995.

DISTRIBUTION SHEET

To	From	Page 1 of 1
Distribution	P. M. Daling/P. J. Certa	Date 10/4/96
Project Title/Work Order		EDT No. 617632
Decision Document, Low-Level Waste Feed Staging Strategy, WHC-SD-WM-TI-788, Rev. 0		ECN No.

Name	MSIN	Text With All Attach.	Text Only	Attach./ Appendix Only	EDT/ECN Only
Central Files (2)	A8-88	X			
DOE Reading Room	H2-53	X			
S. K. Baker	H5-49	X			
V. C. Boyles	R1-43	X			
M. D. Britton	H5-49	X			
P. J. Certa	H5-61	X			
R. D. Claghorn	H5-49	X			
P. M. Daling (5)	K8-07	X			
G. L. Dunford	A2-34				X
J. D. Galbraith	H5-49	X			
J. S. Garfield	H5-49				X
R. A. Kirkbride	H5-27				X
R. P. Marshall	H5-61				X
G. A. Meyer	S2-48				X
W. C. Miller	R1-56				X
C. A. Petersen	H5-27	X			
D. F. Salsman	H6-35				X