



# 2025 ART-GCR Annual Review International Collaborations Overview

July 2025

*Changing the World's Energy Future*

David Alan Reger



**DISCLAIMER**

This information was prepared as an account of work sponsored by an agency of the U.S. Government. Neither the U.S. Government nor any agency thereof, nor any of their employees, makes any warranty, expressed or implied, or assumes any legal liability or responsibility for the accuracy, completeness, or usefulness, of any information, apparatus, product, or process disclosed, or represents that its use would not infringe privately owned rights. References herein to any specific commercial product, process, or service by trade name, trade mark, manufacturer, or otherwise, does not necessarily constitute or imply its endorsement, recommendation, or favoring by the U.S. Government or any agency thereof. The views and opinions of authors expressed herein do not necessarily state or reflect those of the U.S. Government or any agency thereof.

# **2025 ART-GCR Annual Review International Collaborations Overview**

**David Alan Reger**

**July 2025**

**Idaho National Laboratory  
Idaho Falls, Idaho 83415**

**<http://www.inl.gov>**

**Prepared for the  
U.S. Department of Energy  
Under DOE Idaho Operations Office  
Contract DE-AC07-05ID14517**



**GAS-COOLED REACTOR**

ADVANCED REACTOR TECHNOLOGIES PROGRAM

*July 30, 2025*

# Overview of International Collaborations

**David Reger**

*ART-GCR Methods Lead*

INL/MIS-25-86096



**DOE ART-GCR Review Meeting**

*Annual Review Meeting*

**July 29-30, 2025**

# High Temperature Test Reactor (HTTR) Loss of Forced Cooling (LOFC)

- 30MW Gas cooled prismatic reactor capable of reaching 950C (Max.) of helium outlet temperature at 4.0MPa.
- Multiphysics simulation of LOFC tests 1,2, and 3 using NEAMS tools (Pronghorn, Griffin, etc.)

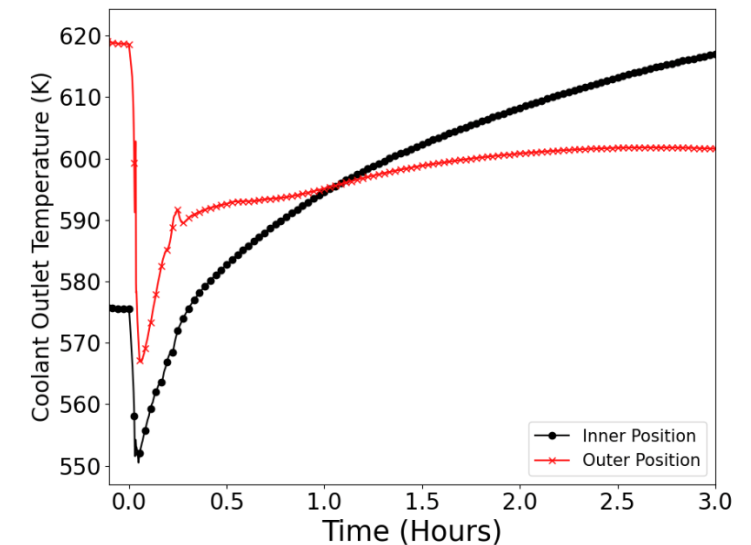



# Civil Nuclear Energy Research and Development Working Group (CNWG)

- From January to March, 2010, the JAEA ramped the reactor power of HTTR from zero to full power and back over 1800 hours.
- Tritium measurements, fluid temperatures, and control rod positions were measured
- NEAMS tools and MELCOR will be used to simulate HTTR and the compare with measured values



# Gen-IV Forum VHTR Computational Methods, Validation, and Benchmarking (CMVB)

- 5 work packages
  - PIRT
  - CFD
  - Reactor Physics
  - Chemistry and Transport
  - Plant Dynamics
- 8 participating countries
  - EU, JP, CN, KR, US, UK, CA, AU

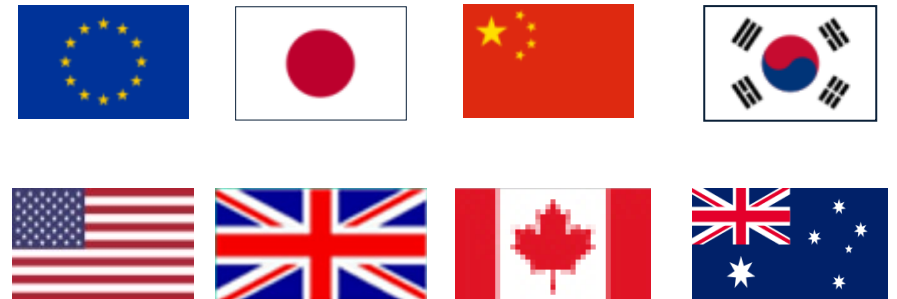

# GIF VHTR CMVB – Work Package 1

- Consolidate knowledge about important phenomena in HTGRs, identify poorly understood phenomena
- Development of a Phenomena Identification and Ranking Table (PIRT) for thermal fluid and core safety phenomena in HTGRs

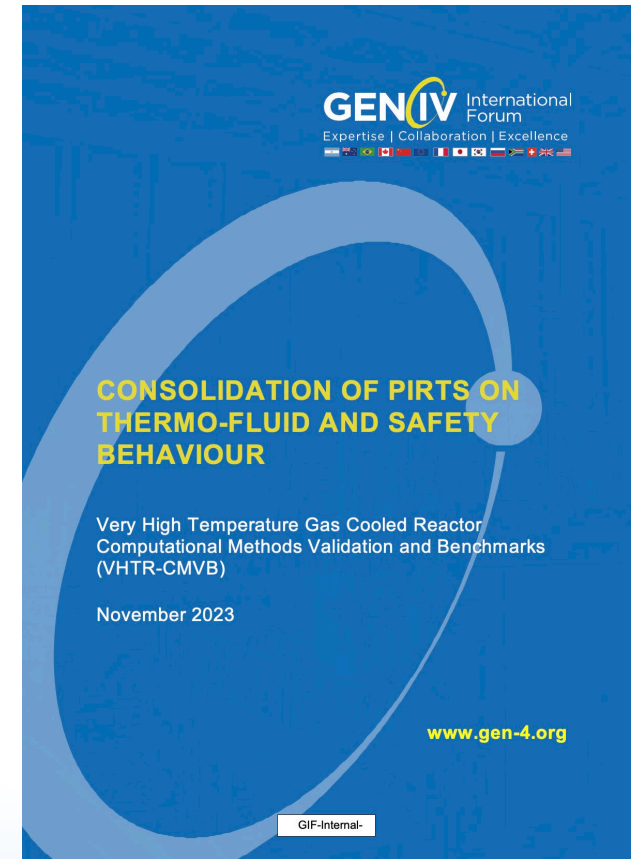

# GIF VHTR CMVB – Work Package 2

- Focuses on validation and benchmarking of CFD tools for several VHTR phenomena

Lower plenum mixing  
INET

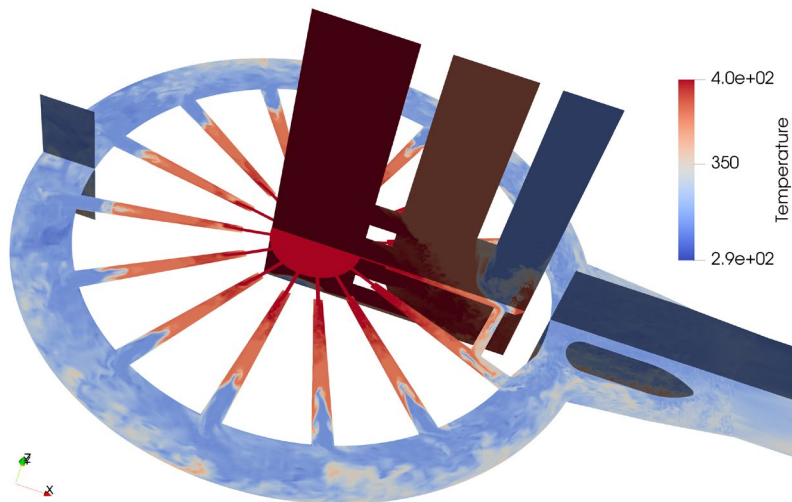

RCCS Performance  
University of Wisconsin - Madison

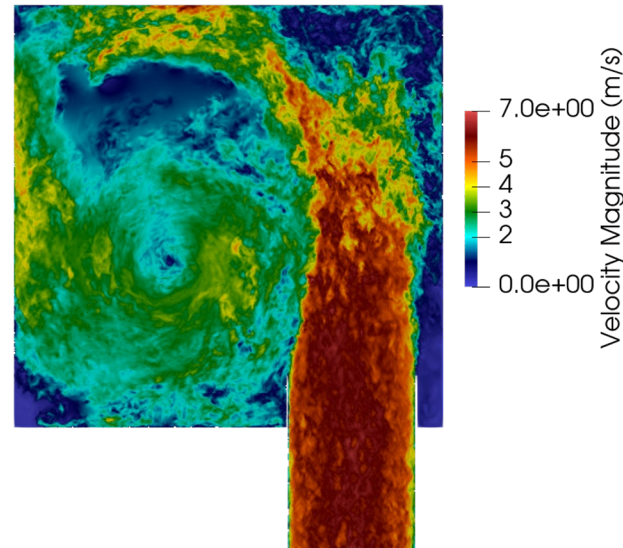

Core Bypass Flow  
INL and KAERI

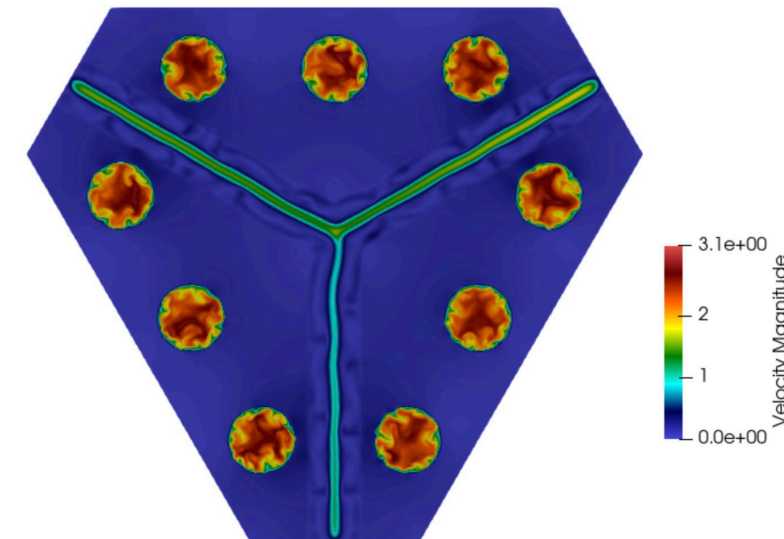

# GIF VHTR CMVB – Work Package 3

- Focused on validation and benchmarking of reactor physics tools

HTR-Proteus  
Paul Scherrer Institute

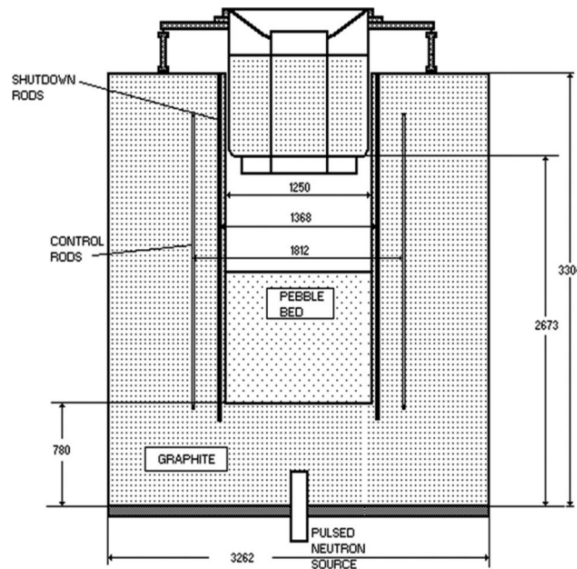

AGR-1 and 2  
INL

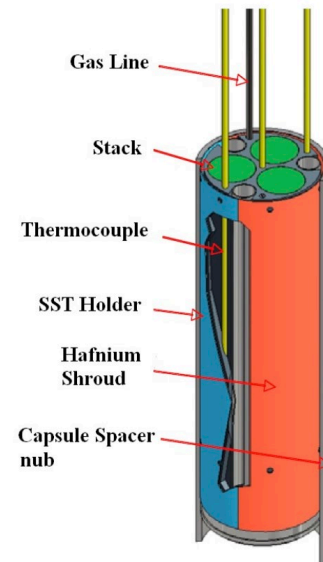

HTR-PM First Criticality  
INET

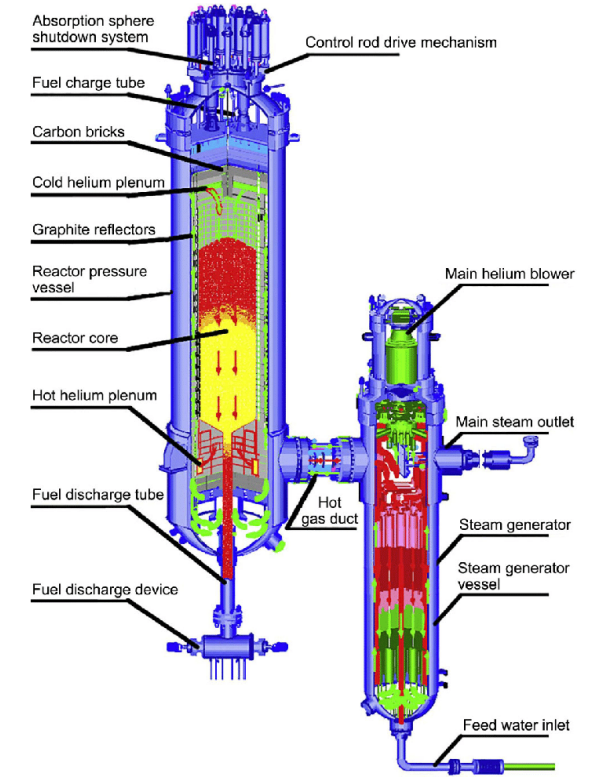

# GIF VHTR CMVB – Work Package 4

- Identify the chemistry and transport scenarios of important radionuclides
- Dust transport and plate out, tritium transport, C-14 transport
- HTR-10, OGL-1, VAMPYR-1 facilities

OGL-1 experiment

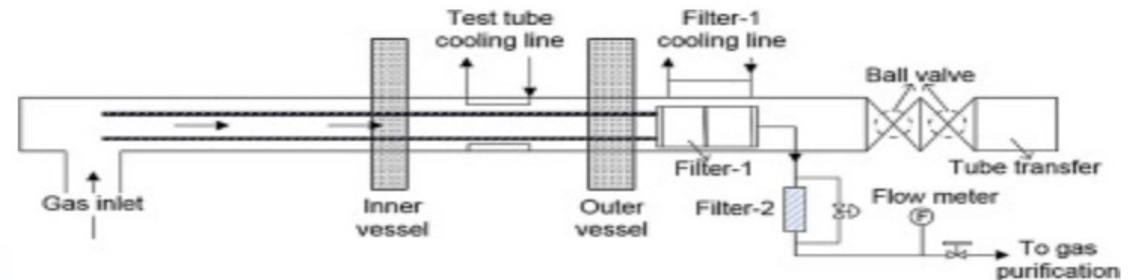
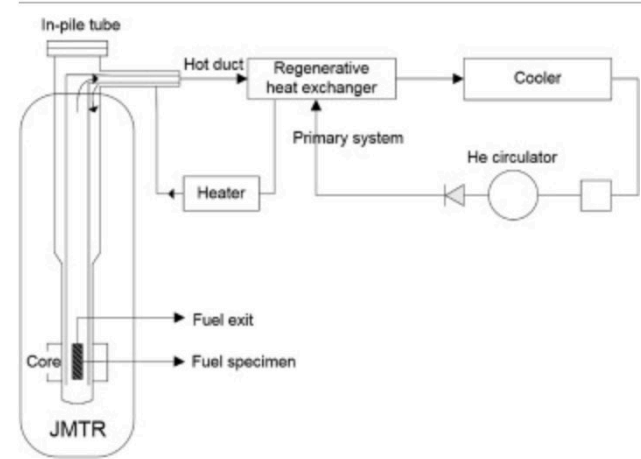

VAMPYR-I experiment

# GIF VHTR CMVB – Work Package 5

- Perform validation and benchmarking of system-level models
- Data from HTR-10, HTTF, NSTF, and other large-scale facilities
- Code-to-code benchmarking with participating countries

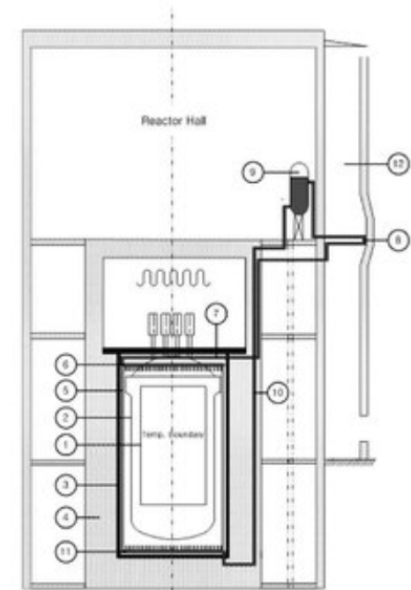

HTR-10 RCCS

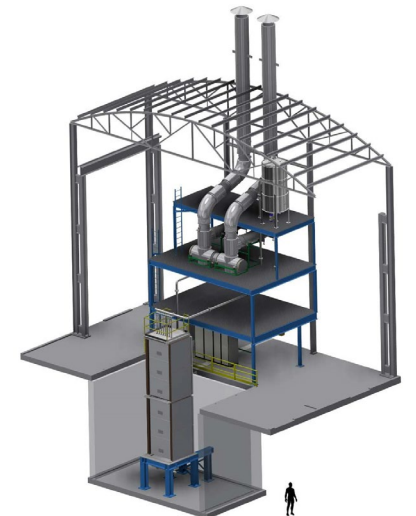

NSTF test facility



# Thank you!

---

**David Reger**  
*david.reger@inl.gov*