



Exceptional service in the national interest

A NEUROSCIENCE PERSPECTIVE ON DENDRITES FOR NEUROMORPHIC COMPUTING

Frances S. Chance

Sandia National Laboratories

NICE 2025, March 27, 2025



Sandia National Laboratories is a multimission laboratory managed and operated by National Technology & Engineering Solutions of Sandia, LLC, a wholly owned subsidiary of Honeywell International Inc., for the U.S. Department of Energy's National Nuclear Security Administration under contract DE-NA0003525.

BIOLOGICAL NEURONS (AND THEIR DENDRITES) ARE COMPLEX

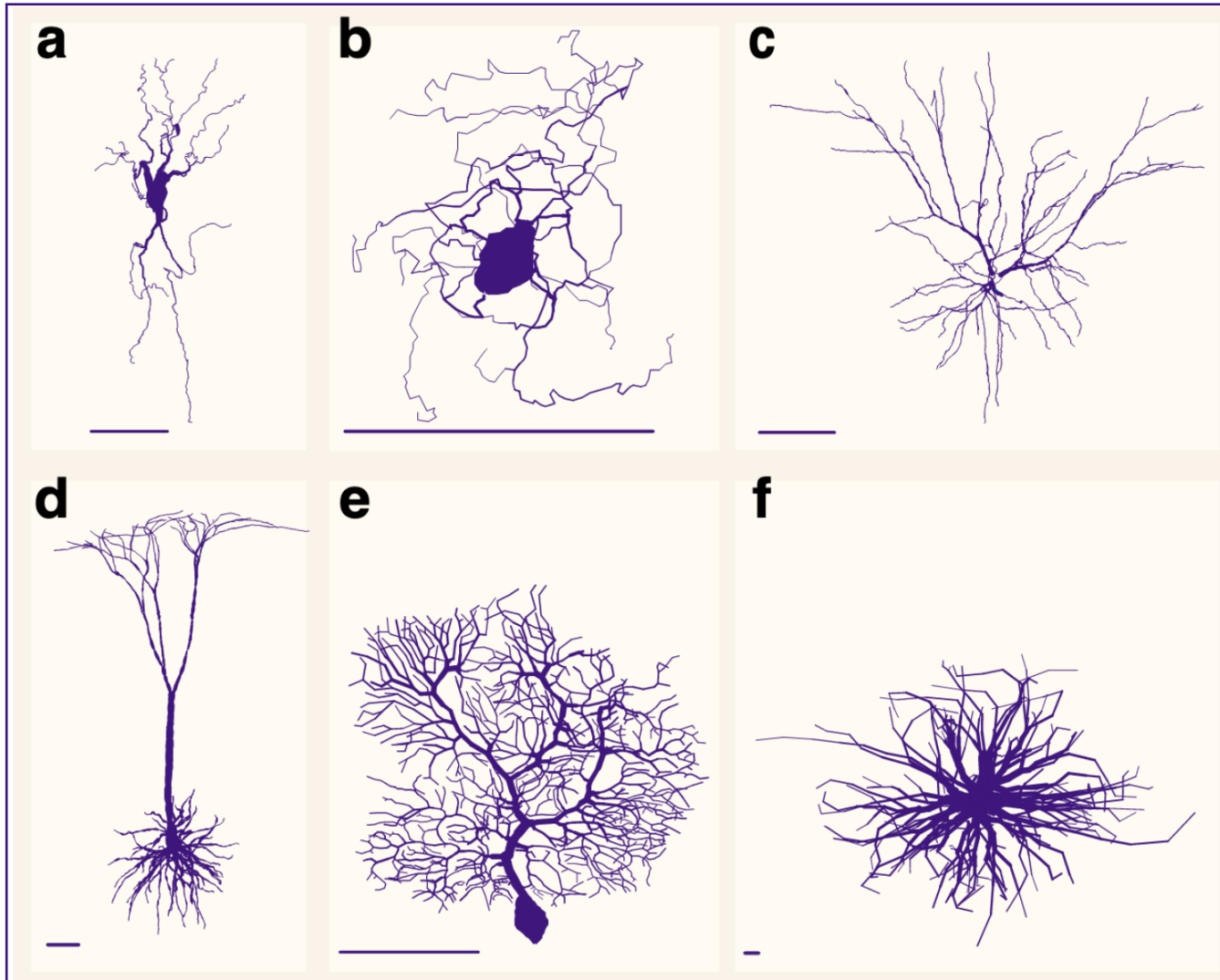

Conventional view: dendrites receive and route synaptic inputs

Biological view: dendrites offer a “computational toolkit”. [London et al 2005]

What inspiration (or tools) should we draw from biology for neuromorphic/ artificial systems?

from Koch & Segev (2000) Nature 3: 1171

DENDRITES ARE NONLINEAR

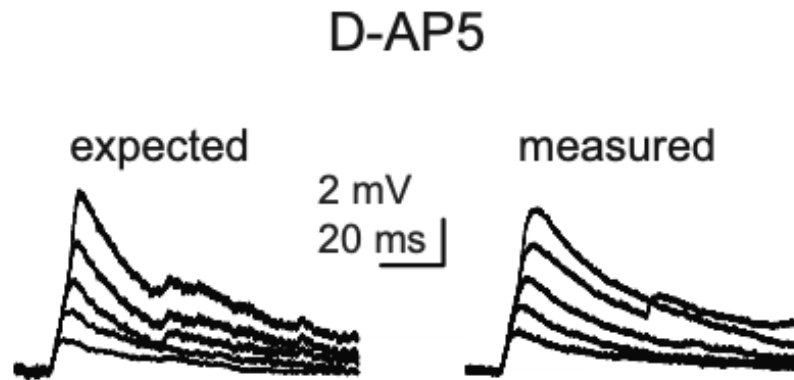
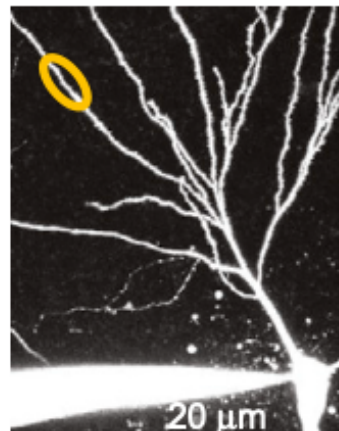
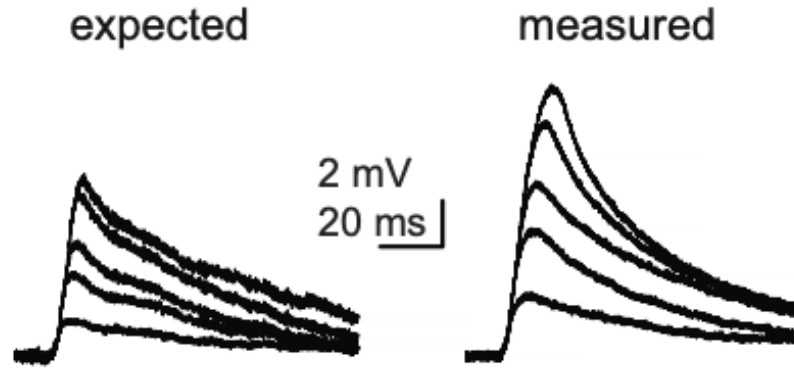

from Makara & Magee 2013

DENDRITIC SPI

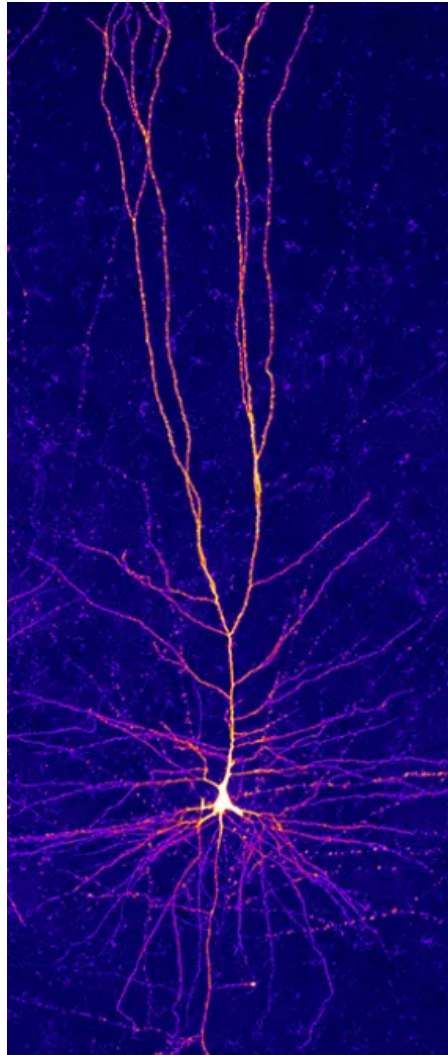

from
<https://thesublimeblog.org/2020/02/18/beautiful-science-dendrites/>

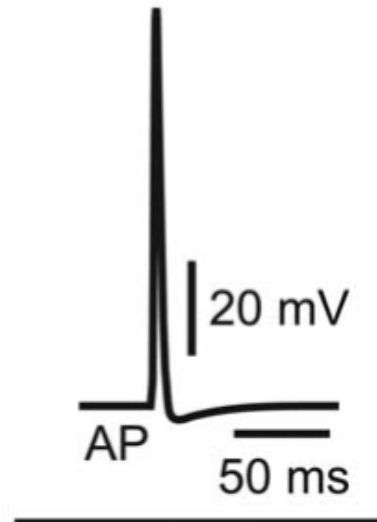

Initiation Site

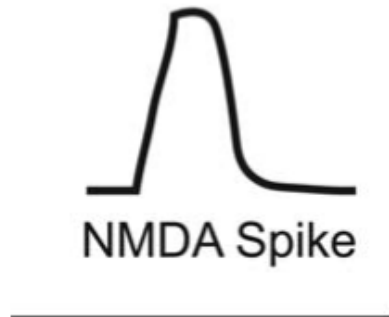
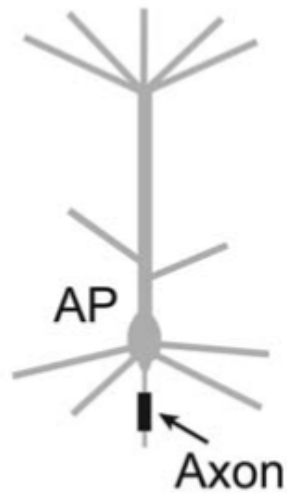

Initiation Sites

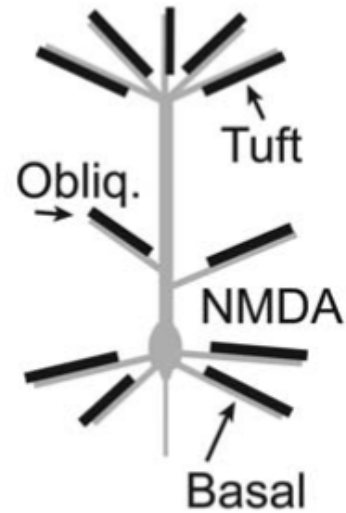

from Antic et al 2010



DENDRITIC SPI

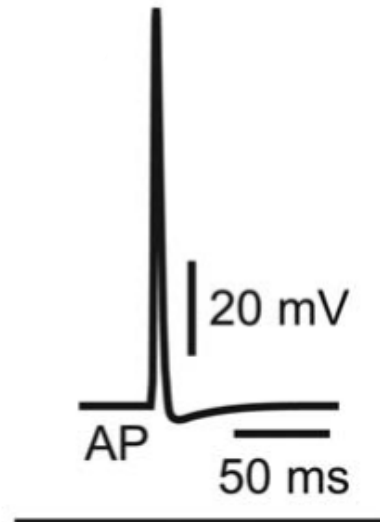
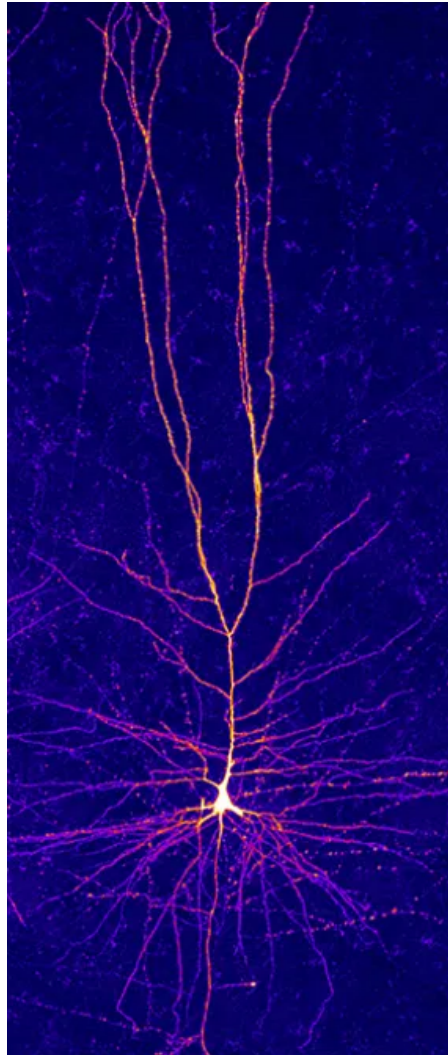

Initiation Site

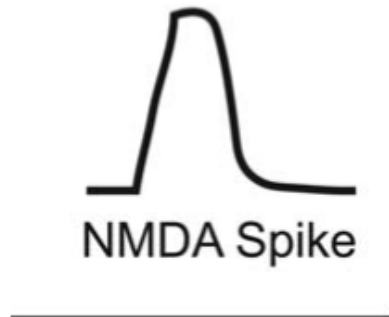
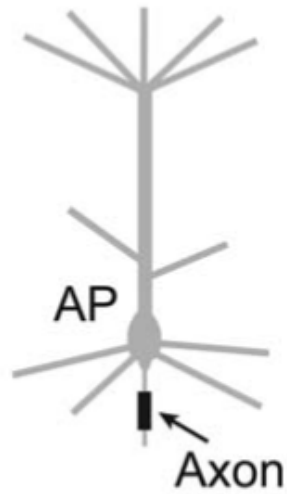

Initiation Sites

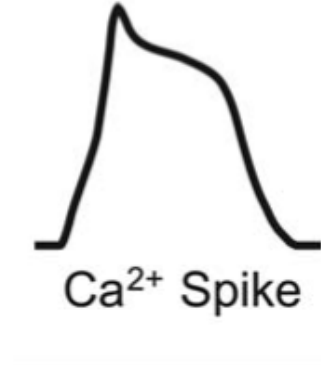
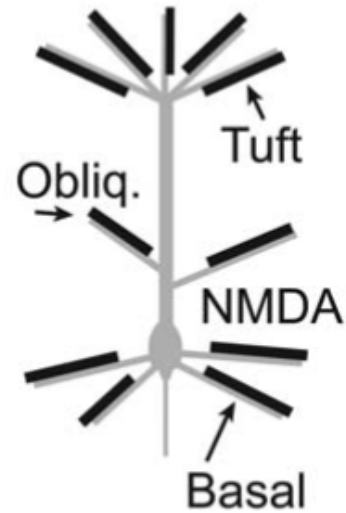

Initiation Site

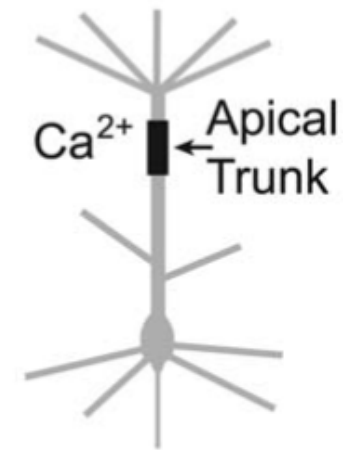

from
<https://thesublimeblog.org/2020/02/18/beautiful-science-dendrites/>

from Antic et al 2010



DENDRITIC SPIKES



NMDA Spike

Initiation Sites

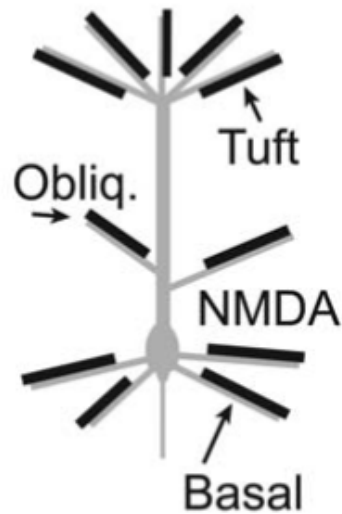

from Antic et al 2010

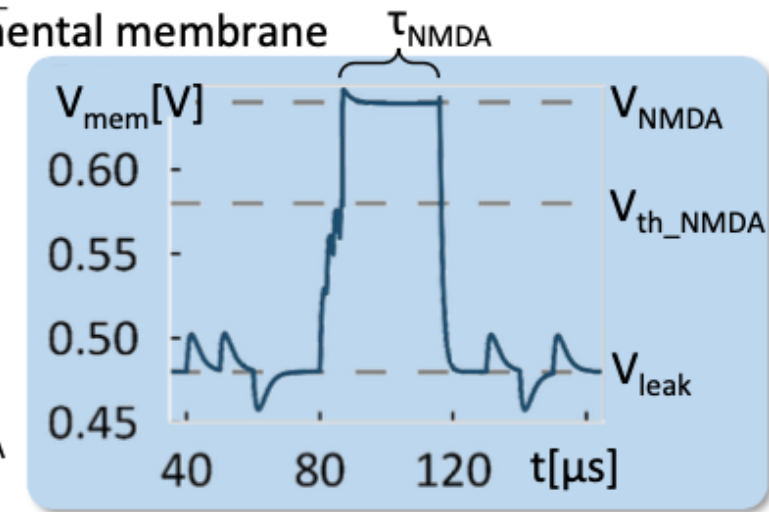
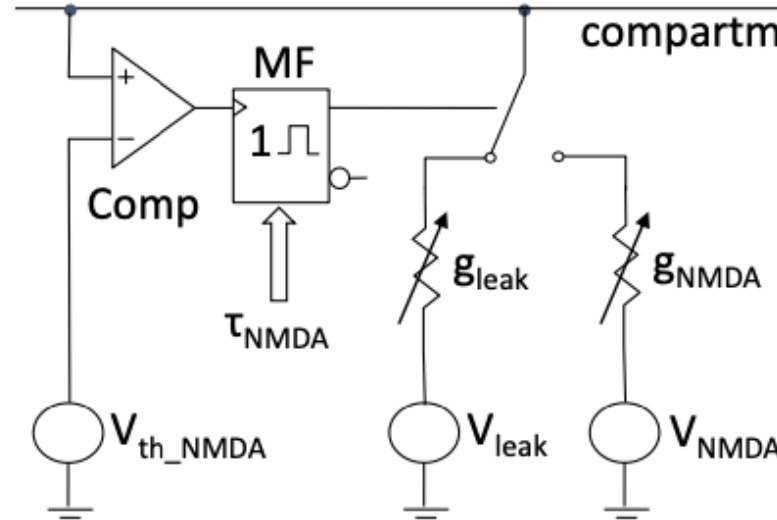

from Schemmel et al 2017



Synaptic inputs to a neuron change both membrane conductance and input current

MEMBRANE CONDUCTANCE IN A NEUROMORPHIC DENDRITE

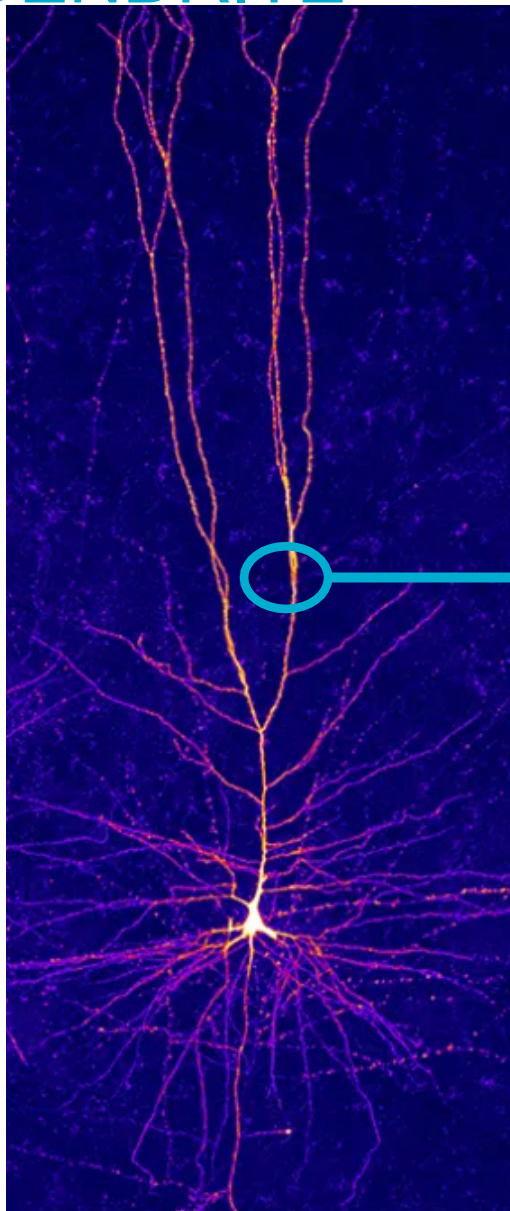

Passive membrane properties were demonstrated by Nease et al in an analog neuromorphic dendrite [IEEE TBioCAS 6: 76, 2012]

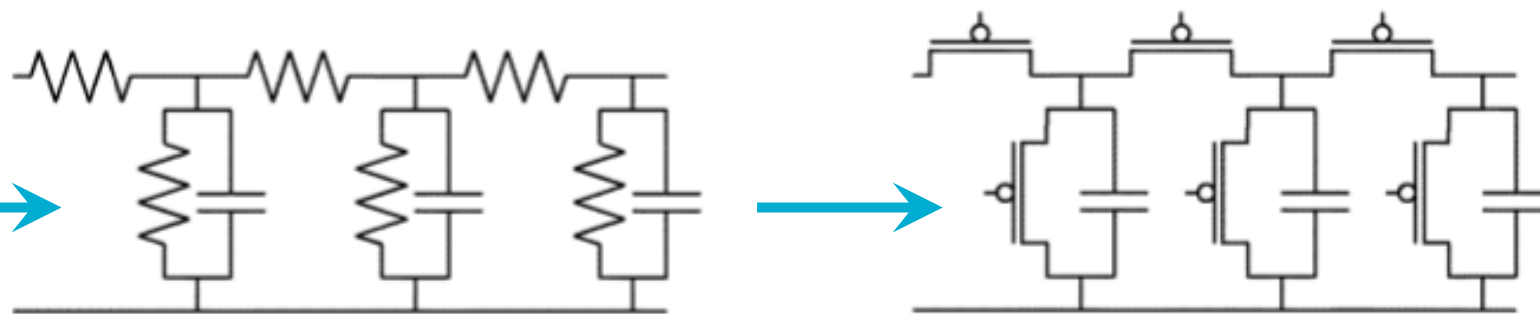

also see George-Cardwell et al 2013

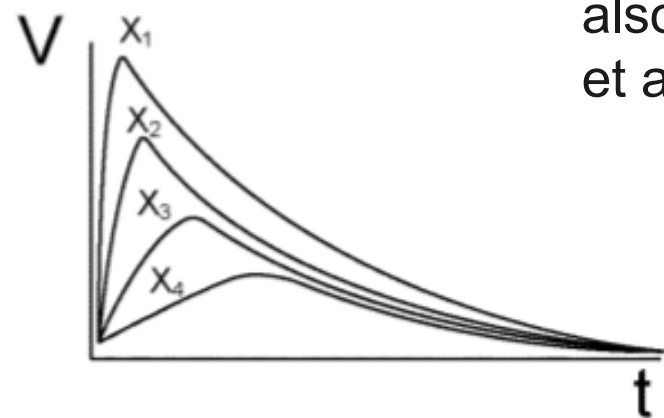

SHUNTING IN A NEUROMORPHIC DENDRITE

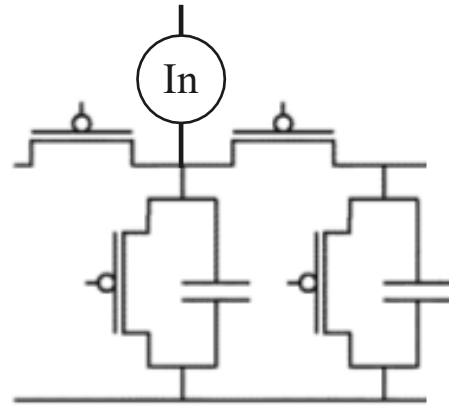
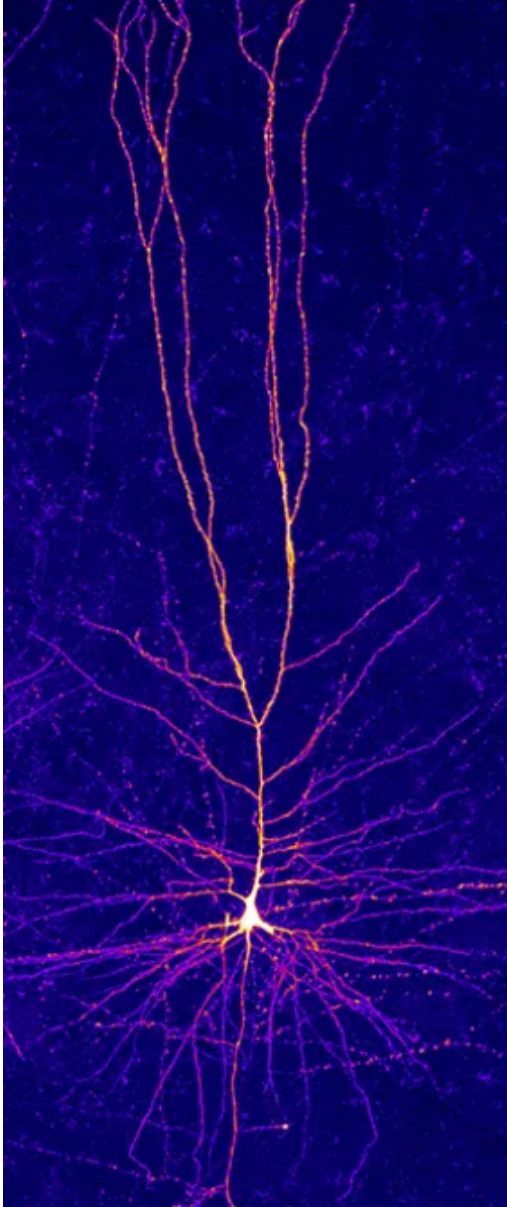

SHUNTING IN A NEUROMORPHIC DENDRITE

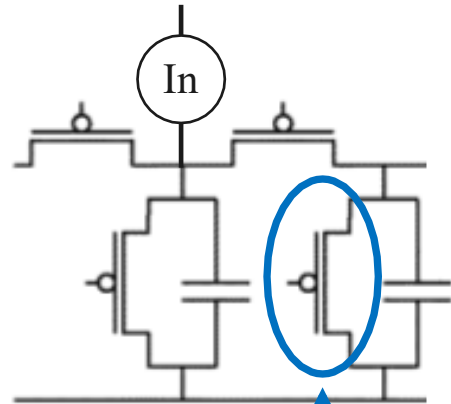
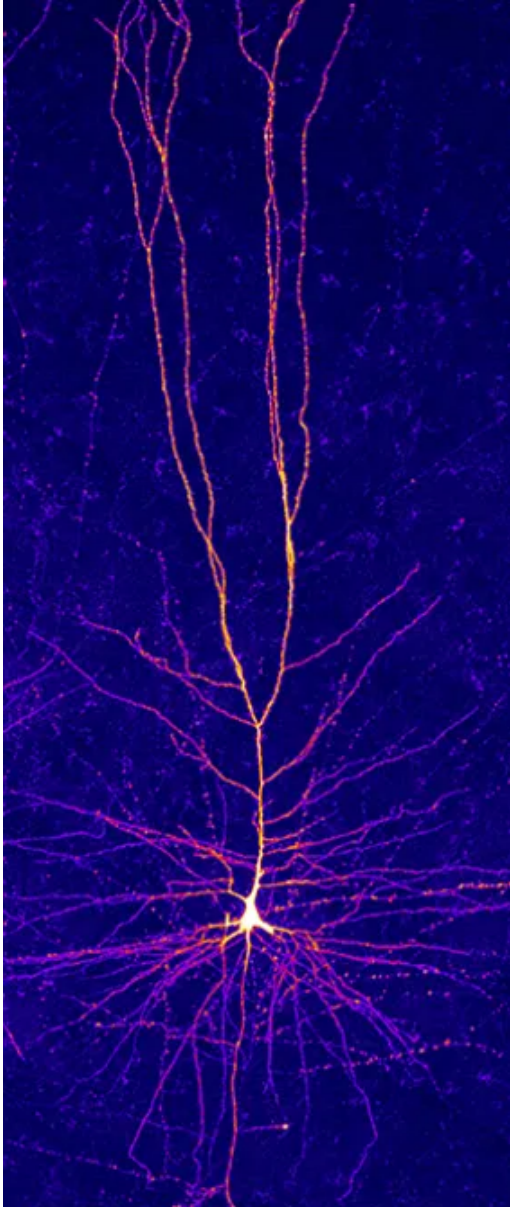

shunting
inhibition

SHUNTING IN A NEUROMORPHIC DENDRITE

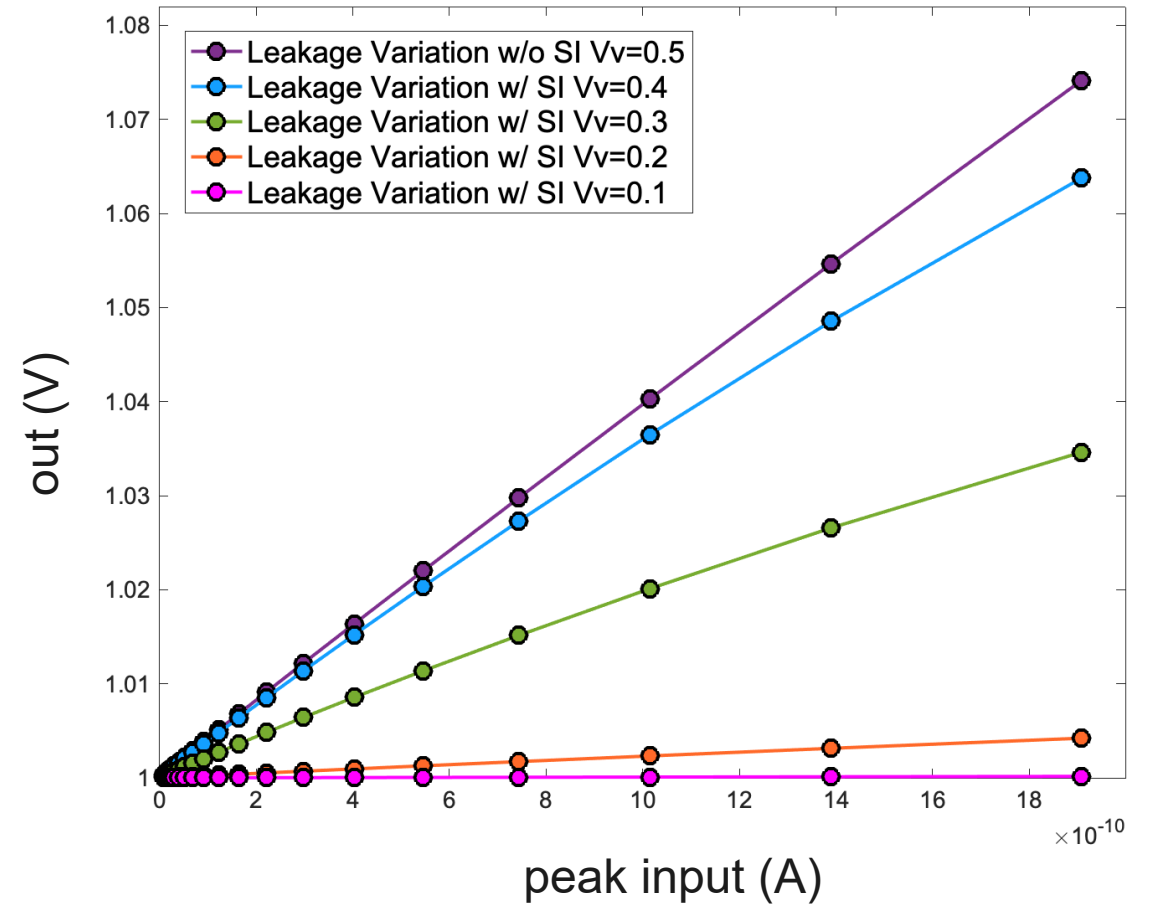
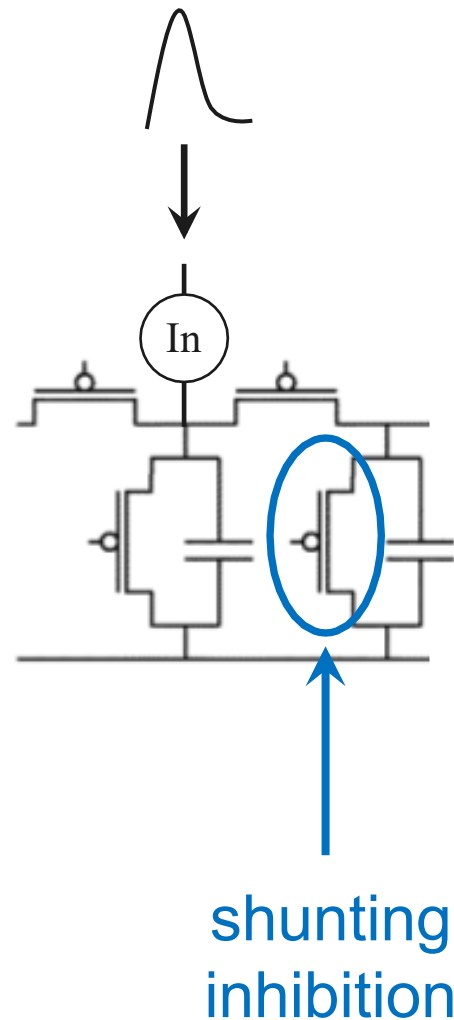
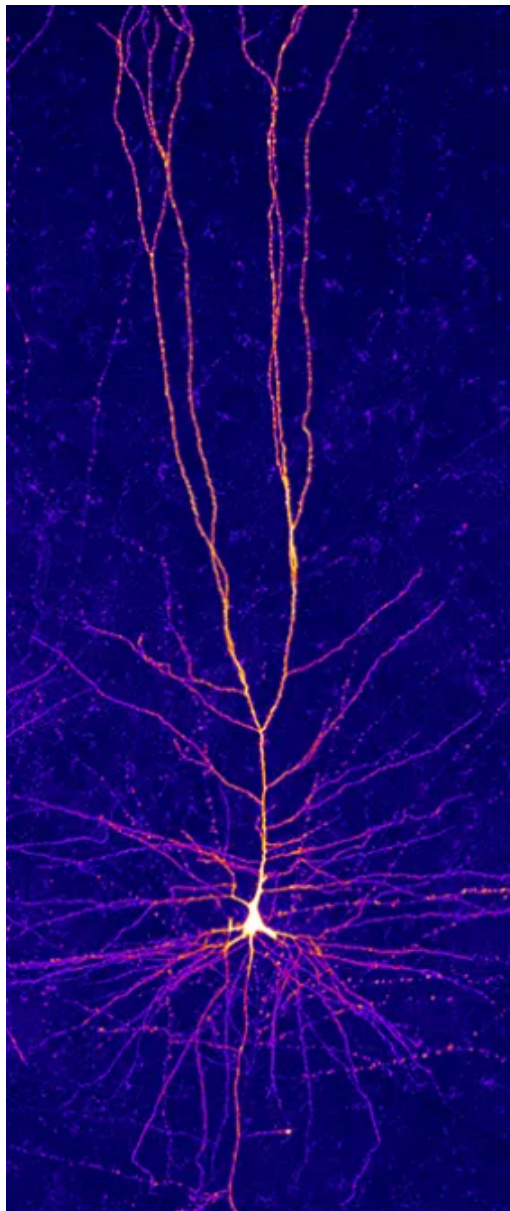

Chance & Cardwell, NICE 2023

SHUNTING ON THE PROXIMAL DENDRITE AS A GATE

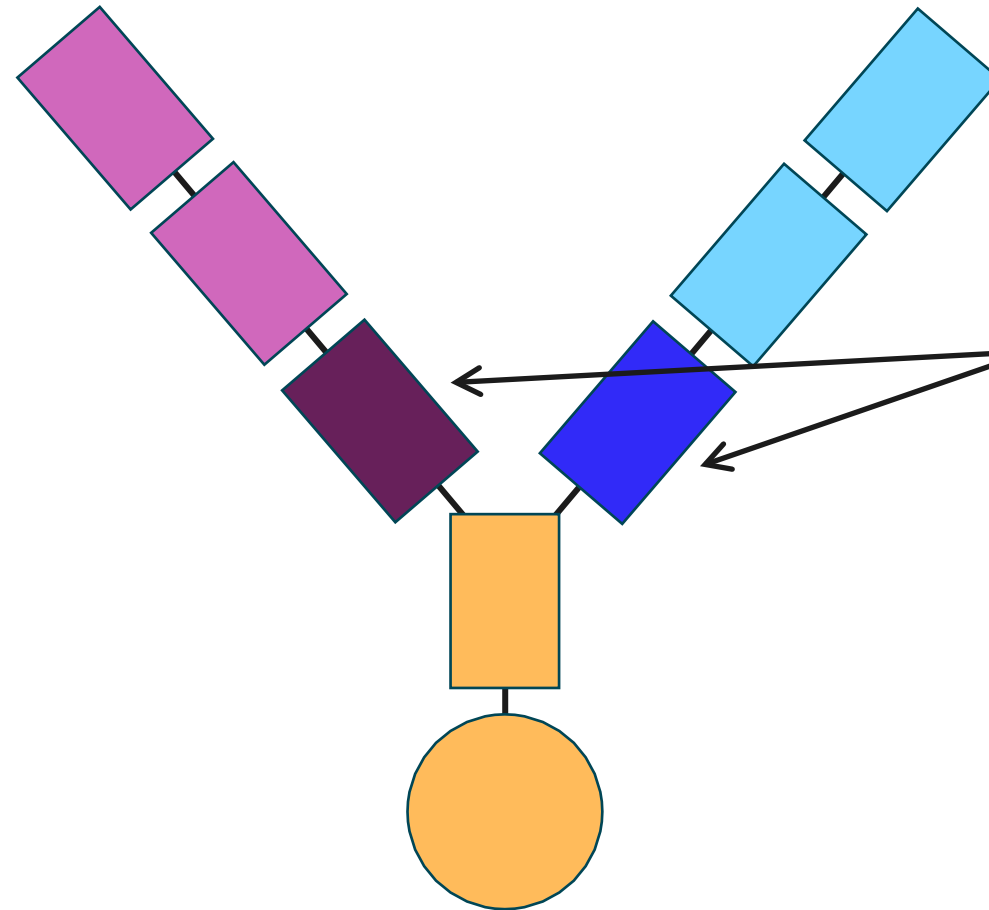

Shunting as attention-like mechanism

INHIBITION ON THE DISTAL DENDRITE AS A GATE



from Gidon & Segev 2012
Neuron 75: 330

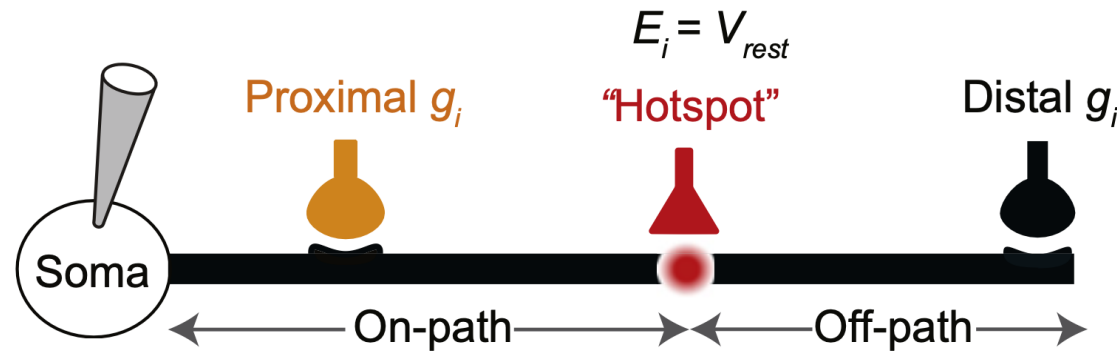

multi-compartment
simulation

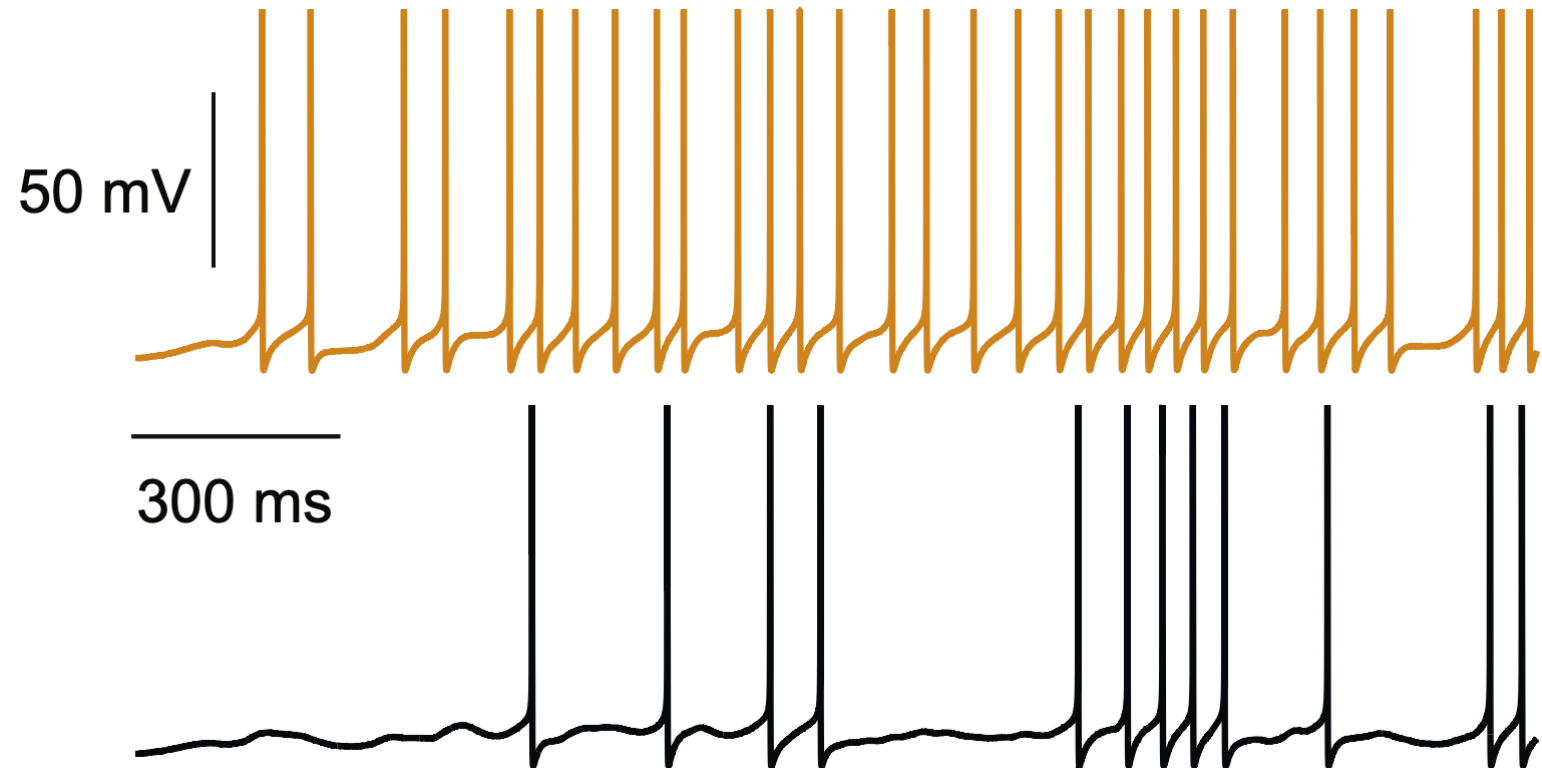

SHUNTING IN A NEUROMORPHIC DENDRITE

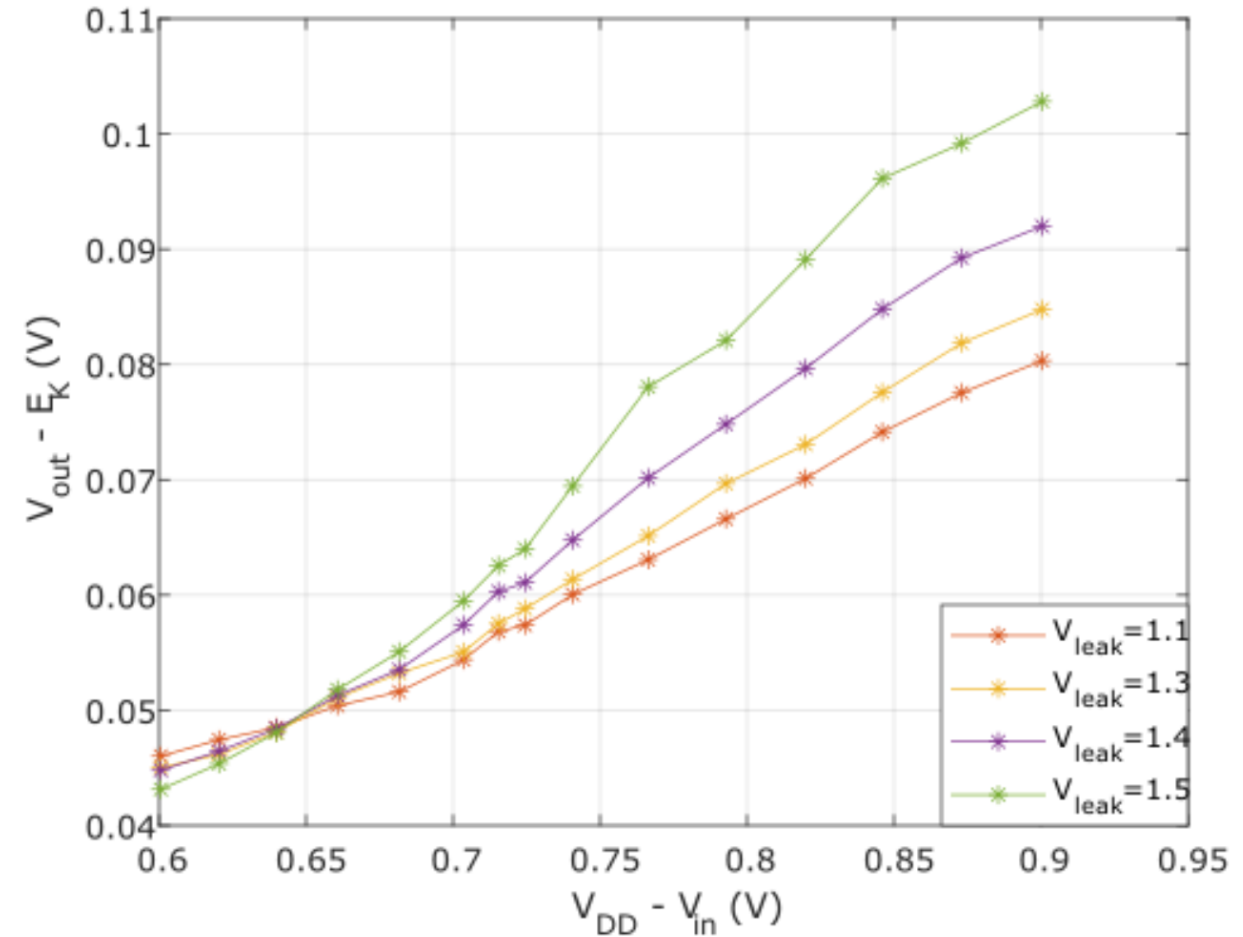
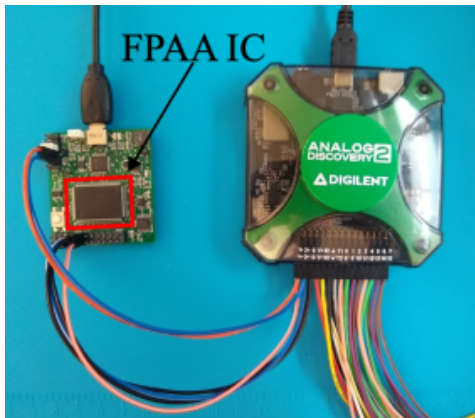
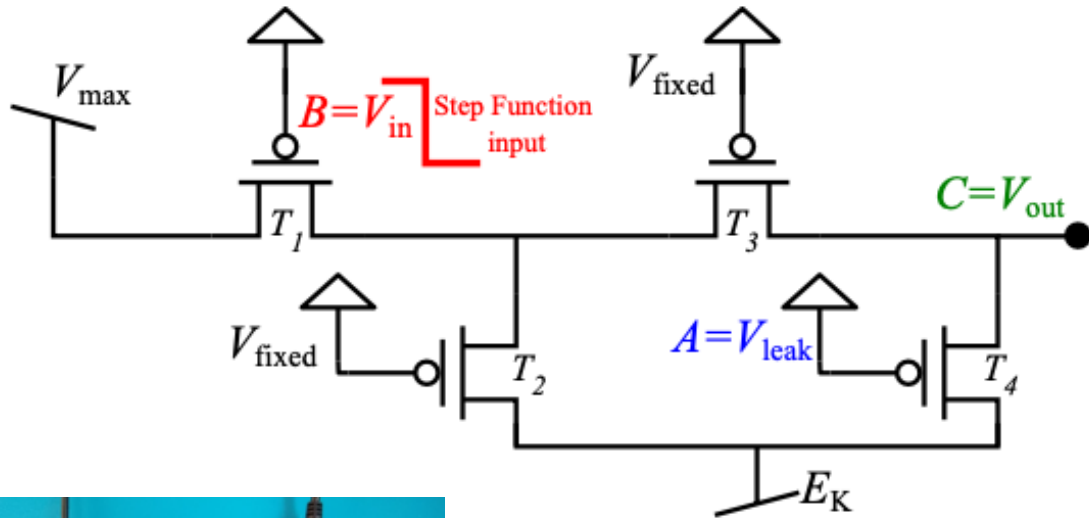

DIRECTION SELECTIVITY FROM SHUNTING IN A BIOLOGICAL DENDRITE

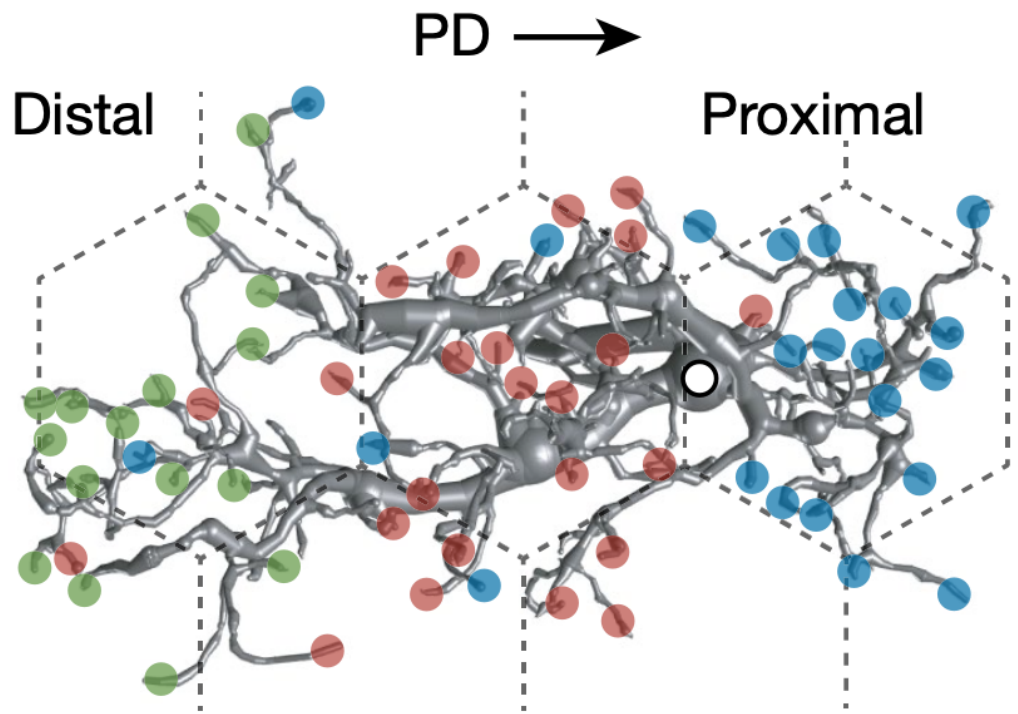

- Column border
- T4 dendrite
- Axon root
- Glutamate
- Acetylcholine
- GABA

adapted from Groschner et al, 2022 Nature 603: 119

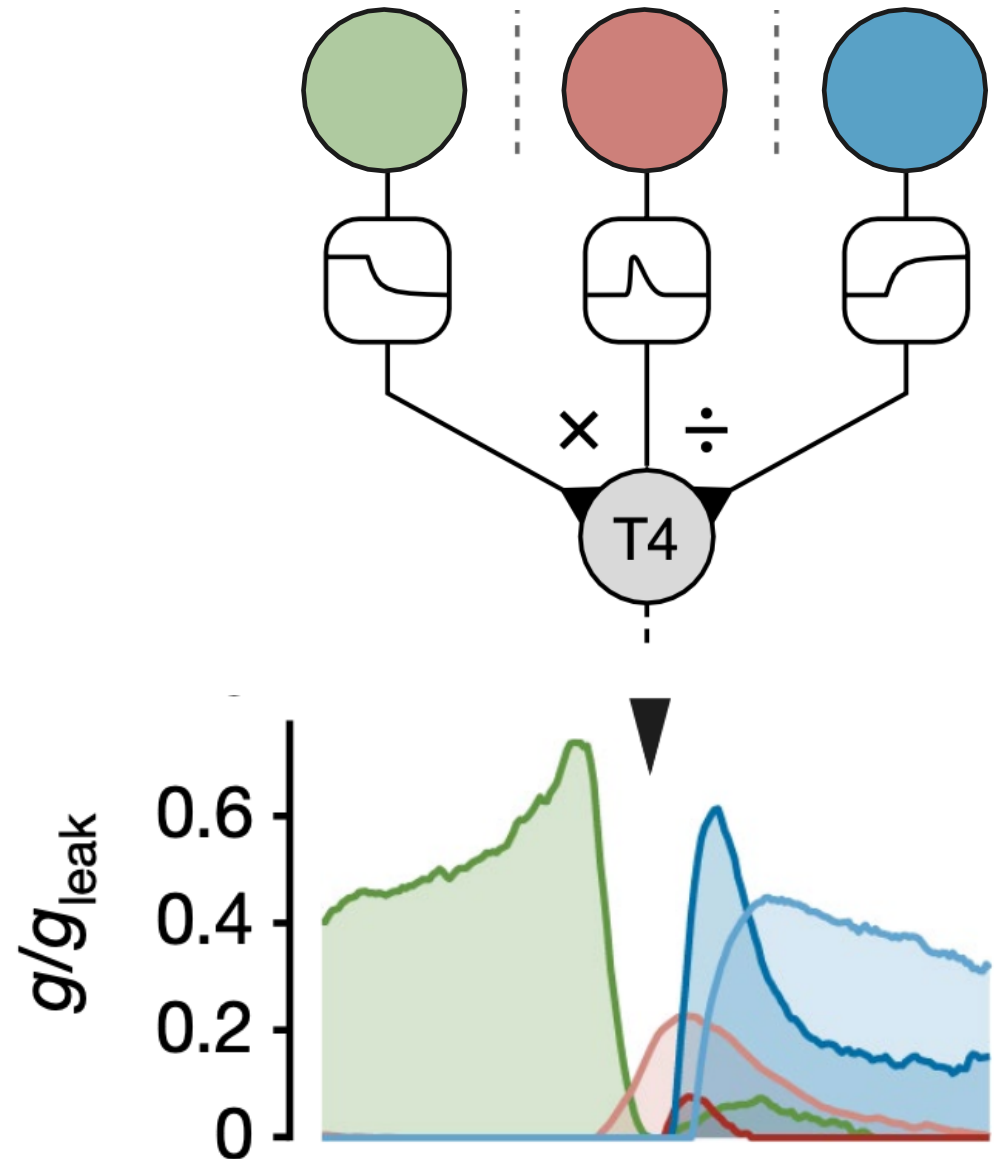

DIRECTION SELECTIVITY FROM SHUNTING IN A NEUROMORPHIC DENDRITE

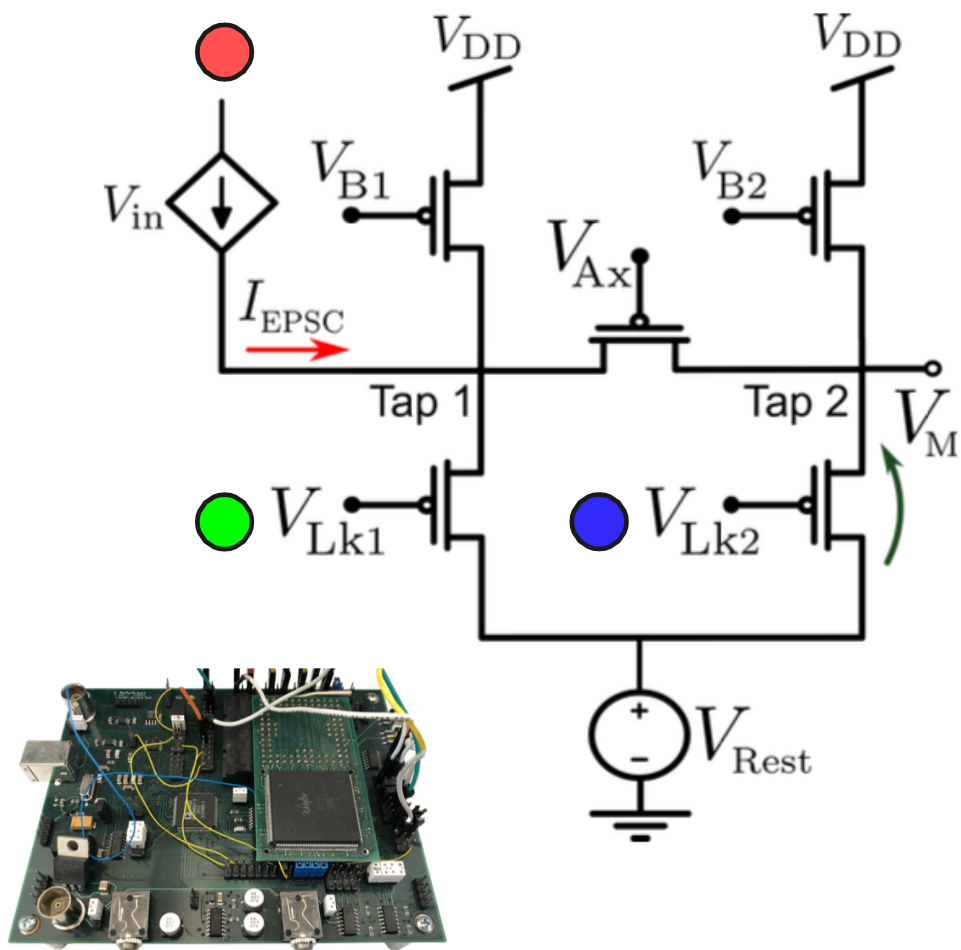

Stimulus Moves in Preferred Direction

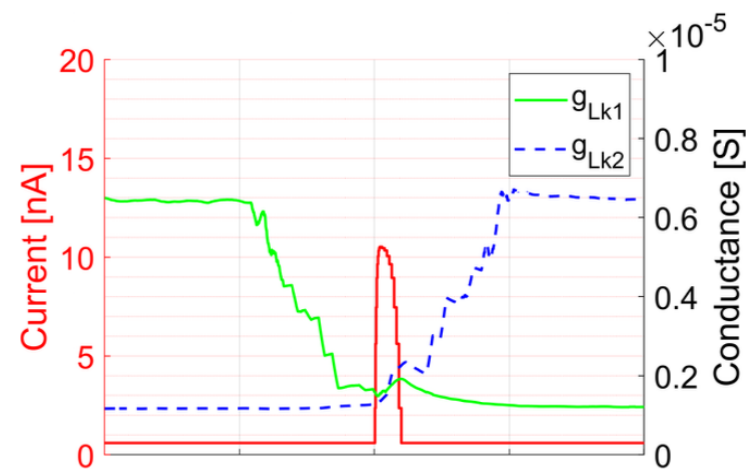

Stimulus Moves in Non-Preferred Direction

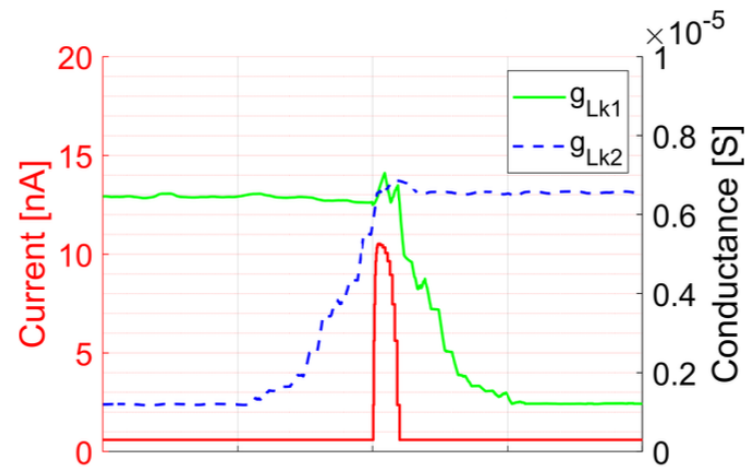

from Parker et al ICONS 2024

DIRECTION SELECTIVITY FROM SHUNTING IN A NEUROMORPHIC DENDRITE

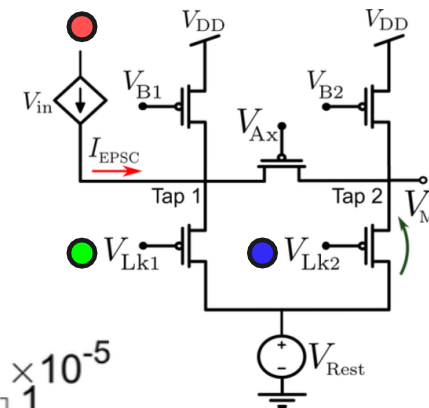

Preferred Direction

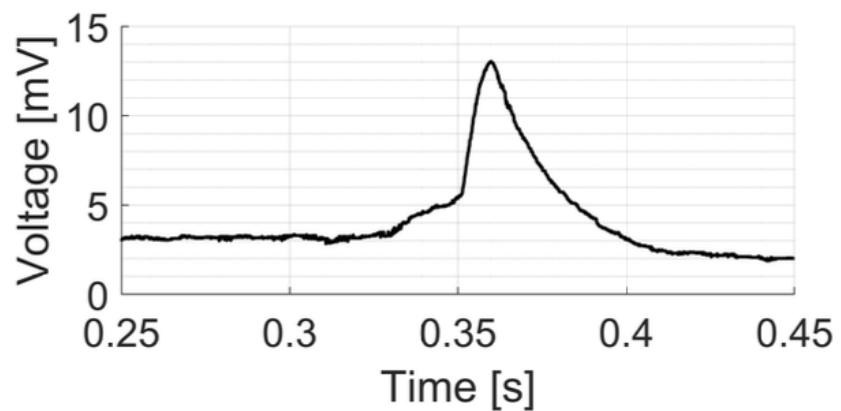
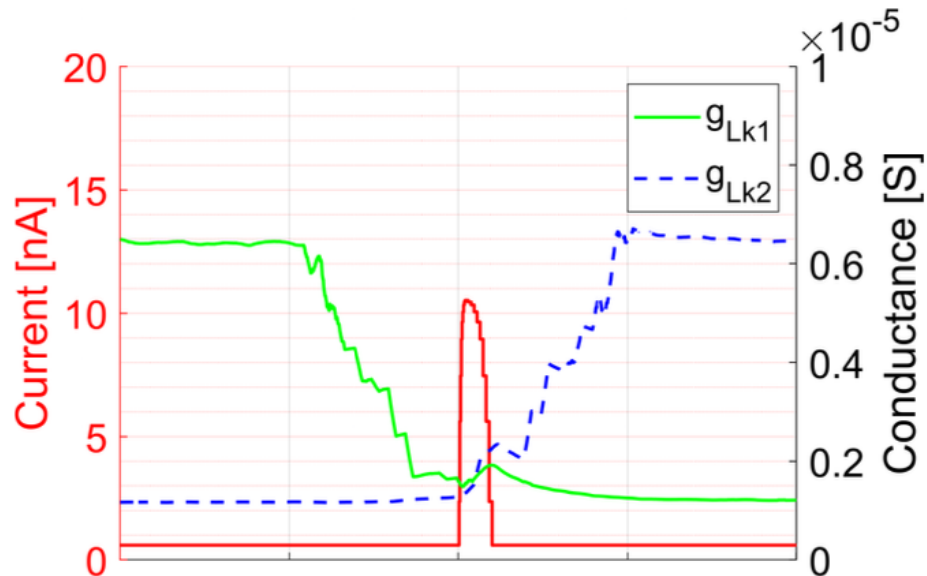

Non-Preferred Direction

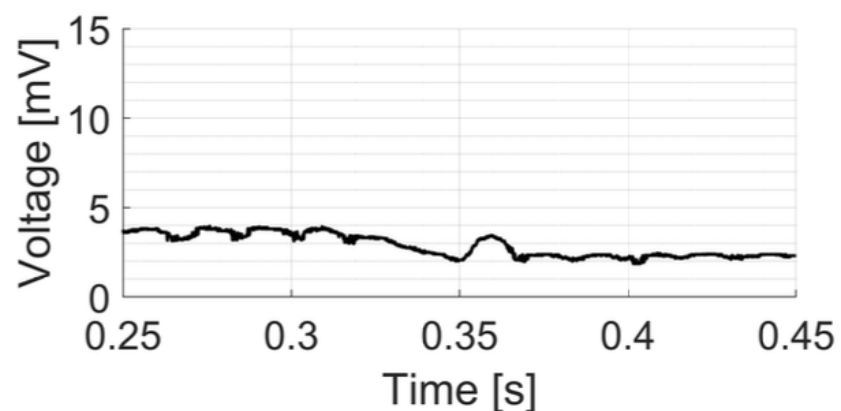
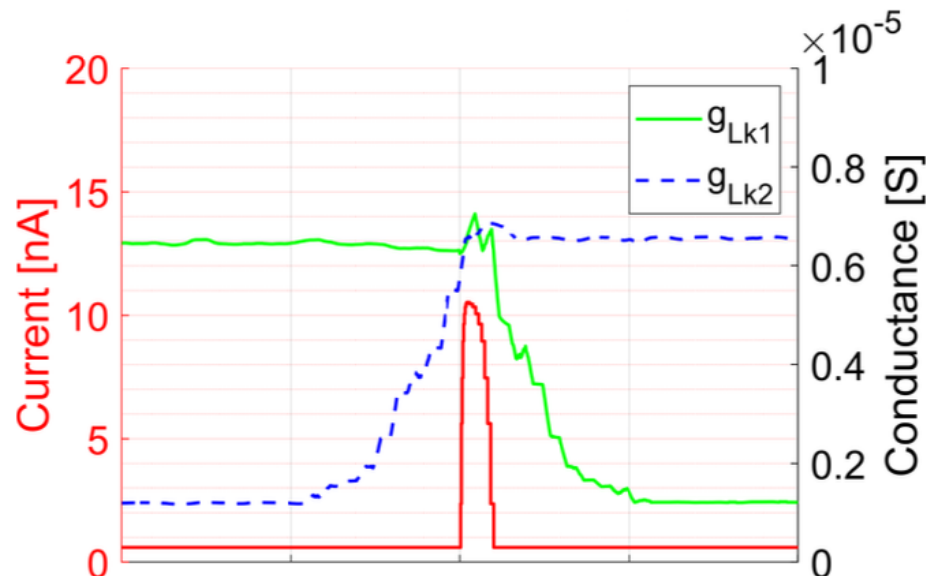

DIRECTION SELECTIVITY FROM SHUNTING IN A NEUROMORPHIC DENDRITE

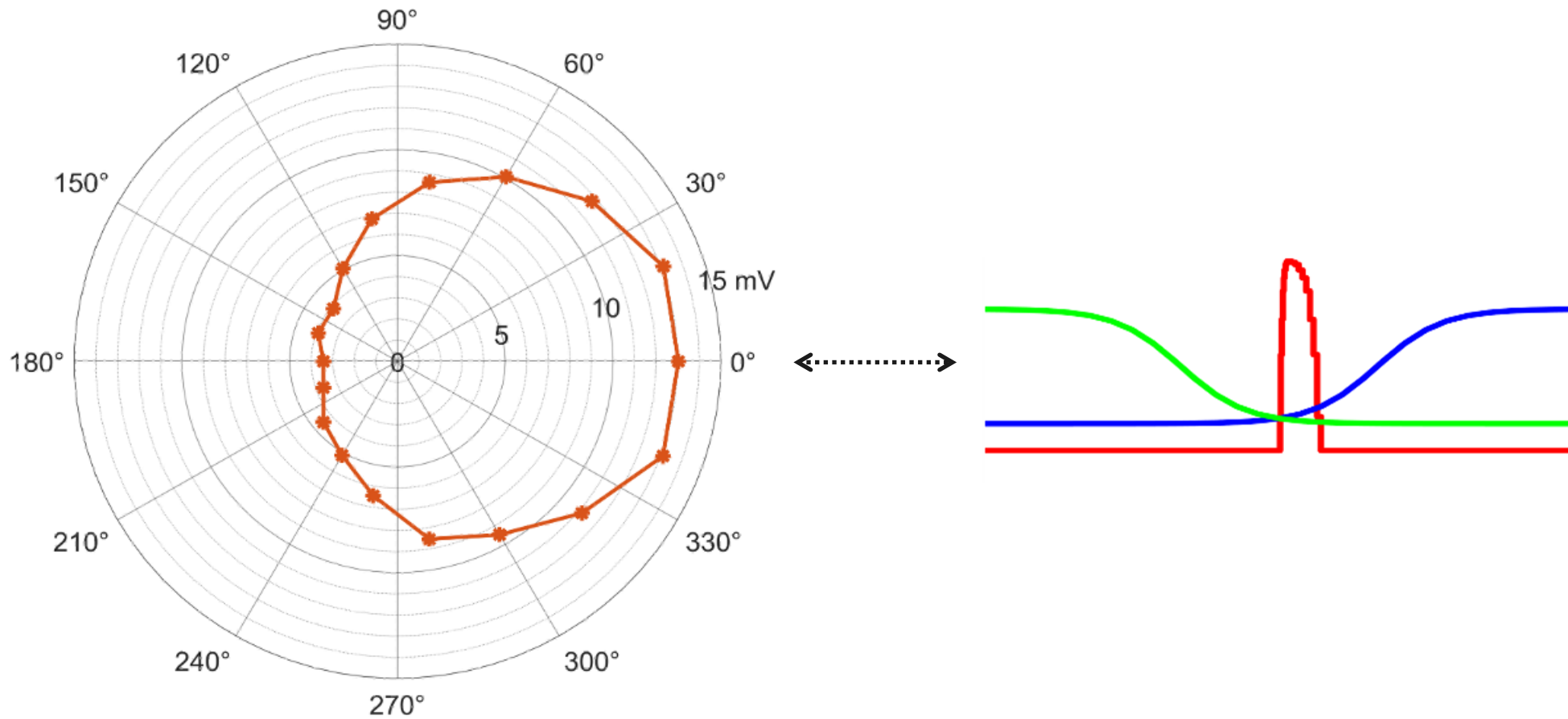

from Parker et al ICONS 2024

DIRECTION SELECTIVITY FROM SHUNTING IN A NEUROMORPHIC DENDRITE



U.S. DEPARTMENT OF
ENERGY

Office of
Science



Neuromorphic

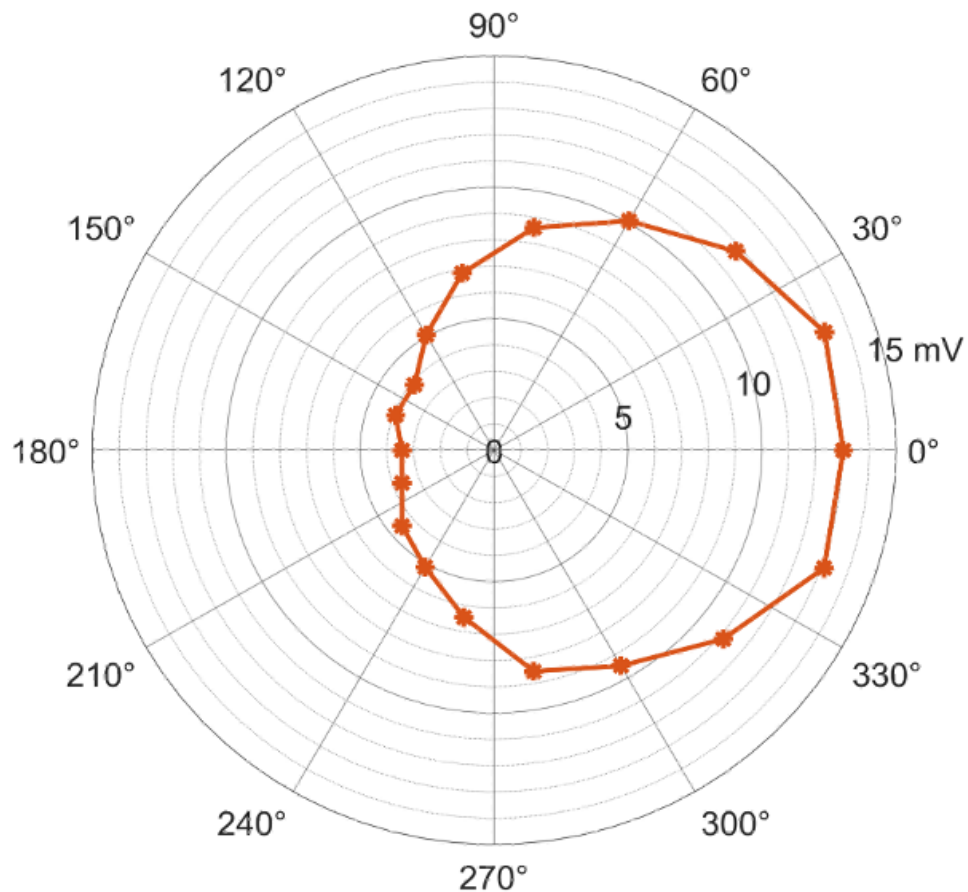

Biological Data

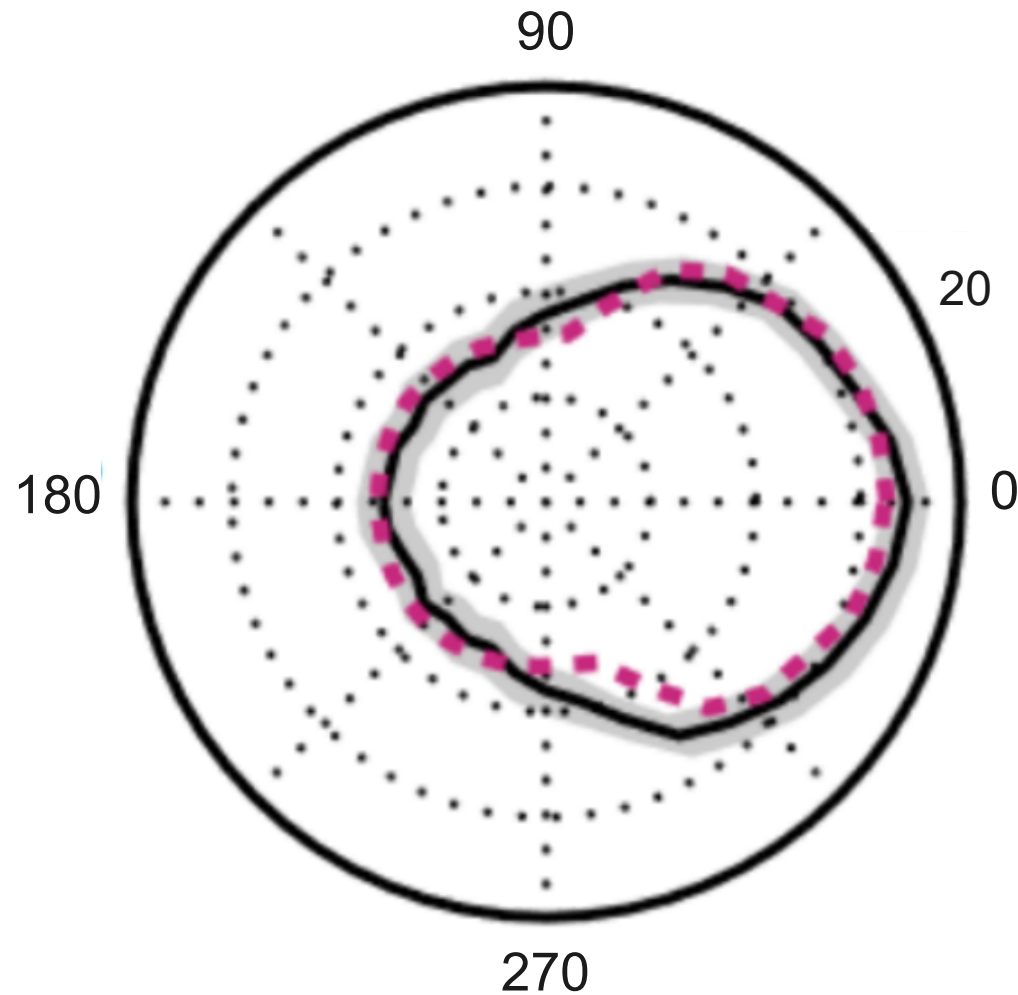

from Parker et al ICONS 2024

CONDUCTANCE CHANGE AS A GATE: COINCIDENCE DETECTION IN NUCLEUS LAMINARIS



Phase shift: 180°

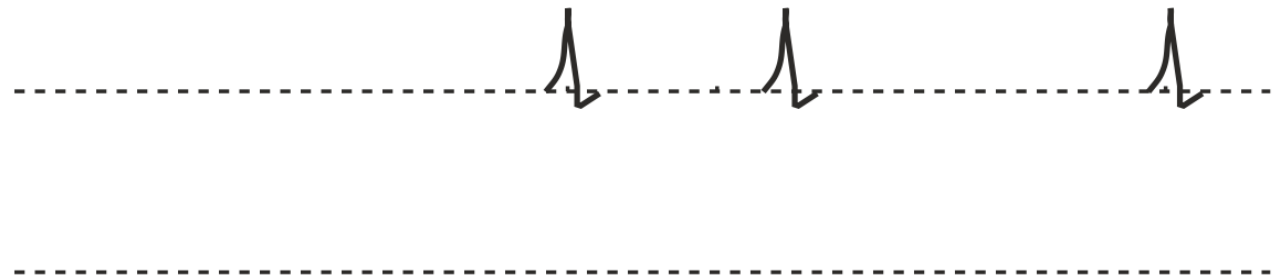
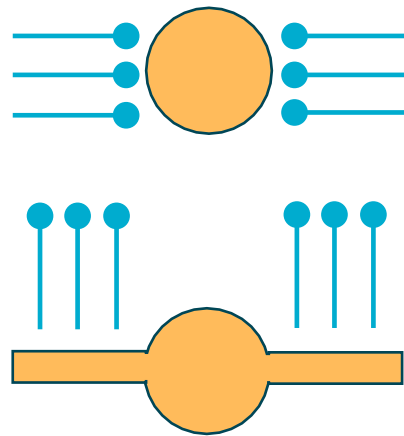
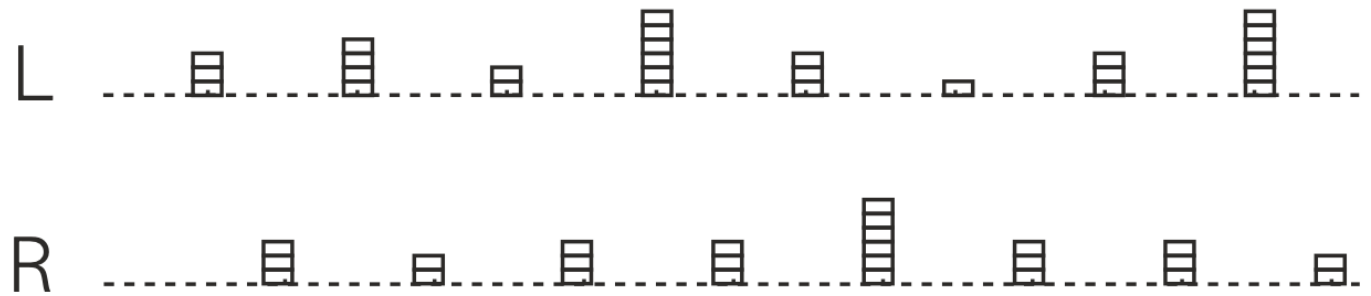

CONDUCTANCE CHANGE AS A GATE: ANTI-COINCIDENCE (XOR)

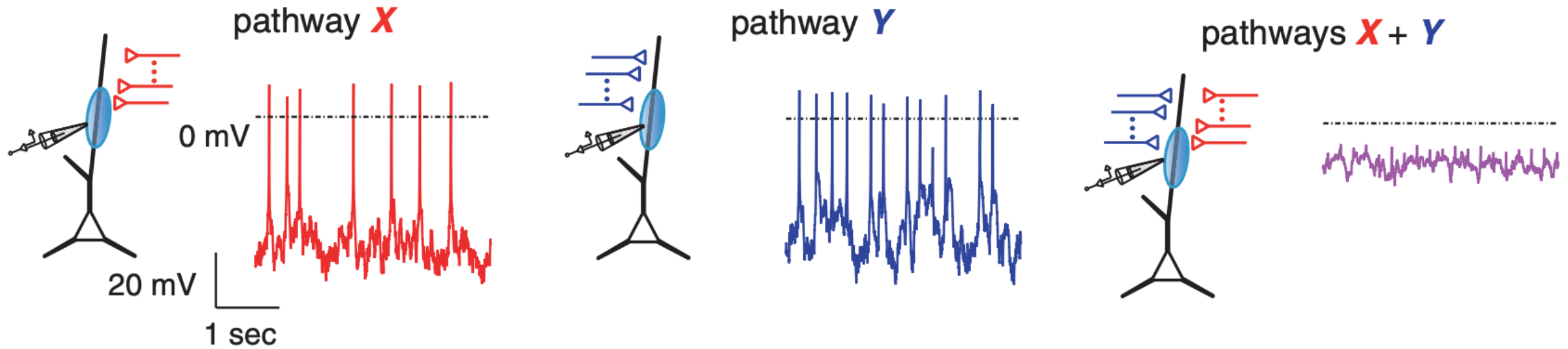

Coincident inputs (in time and space) can shunt each other, resulting in anti-coincidence

Gidon et al 2024 Science 367: 1

CONDUCTANCE CHANGE AS A GATE: ANTI-COINCIDENCE (XOR)

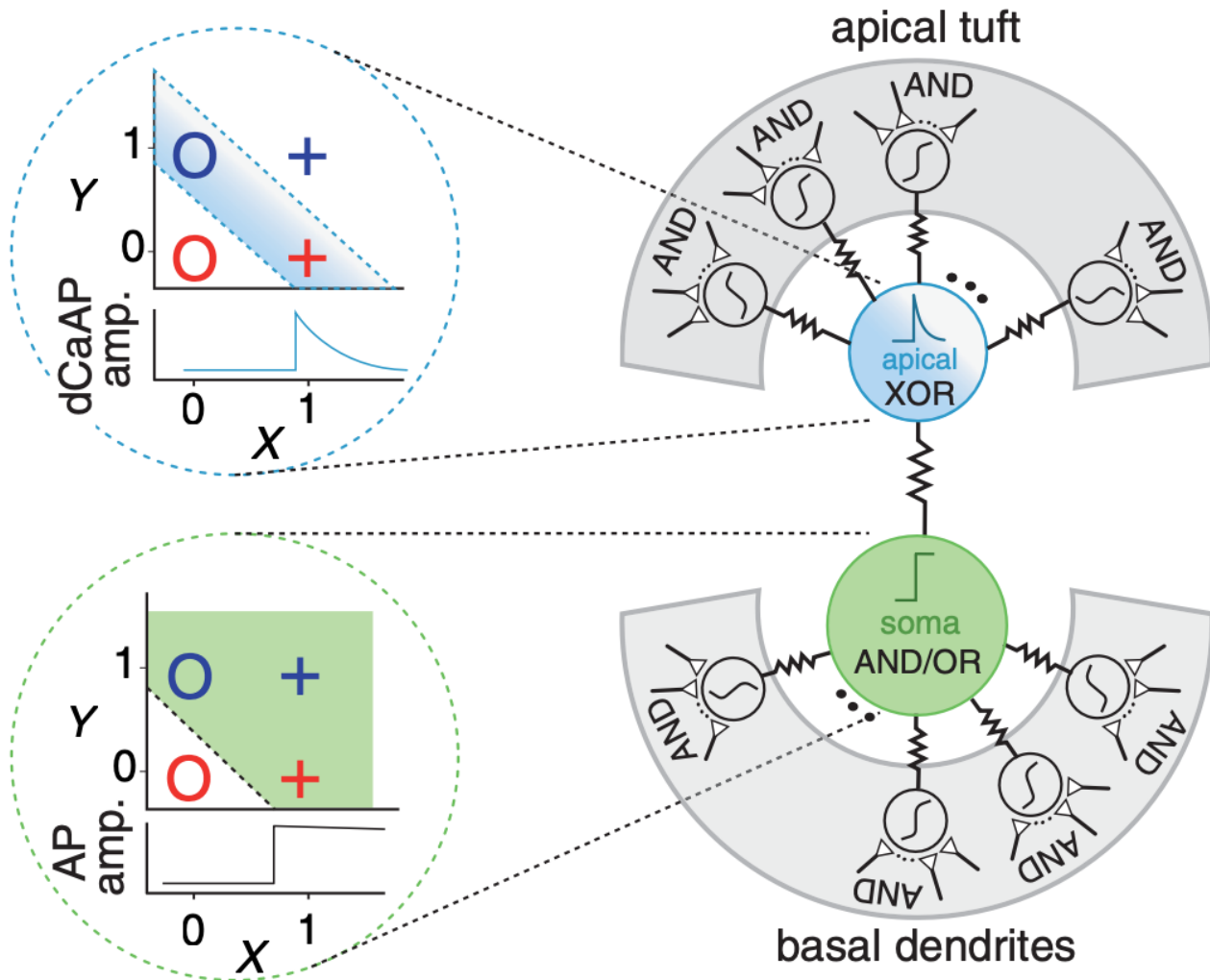

Coincident inputs (in time and space) can shunt each other, resulting in anti-coincidence or XOR function.



Dendrites do much more than route synaptic inputs to soma

Example Dendritic Nonlinearities

Supralinear summation

Sublinear summation

(also linear summation)

Dendritic spikes

Direction-selectivity



Dendrites do much more than route synaptic inputs to soma

Local Processing through Conductance Changes

Multiplicative gain modulation

Coincidence detection

Anti-coincidence detection

DENDRITES AS NEURAL NETWORKS



Dendrites have been compared to neural networks

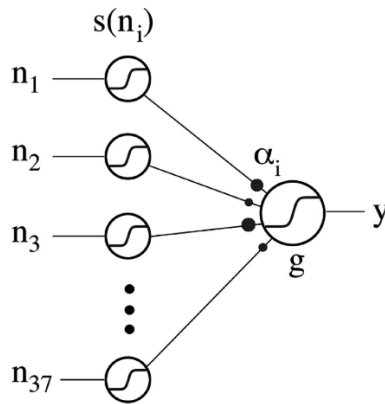

from Poirazi & Mel 2003
Neuron 37: 989

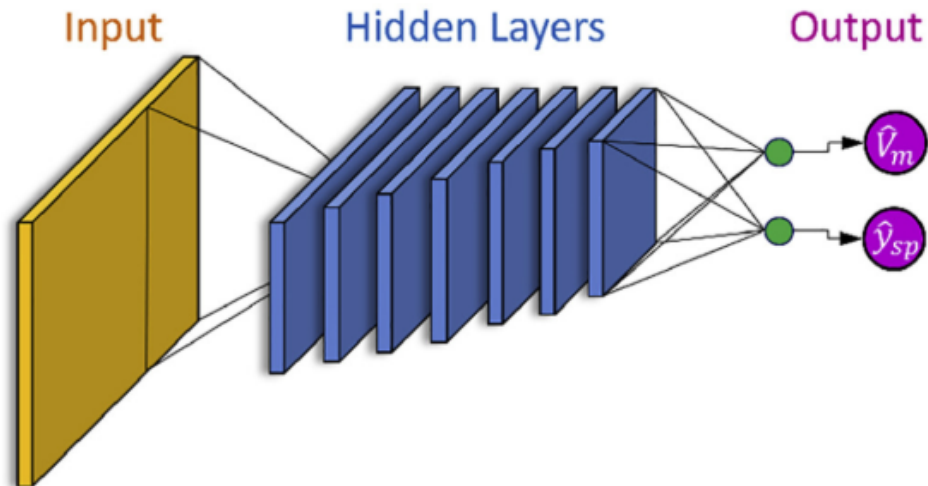

from Beniaguev et al 2021
Neuron 109: 2727

THE END



FSCCHANC@SANDIA.GOV

BACKUP SLIDES

BIOLOGICAL NEURONS (AND THEIR DENDRITES) ARE COMPLEX

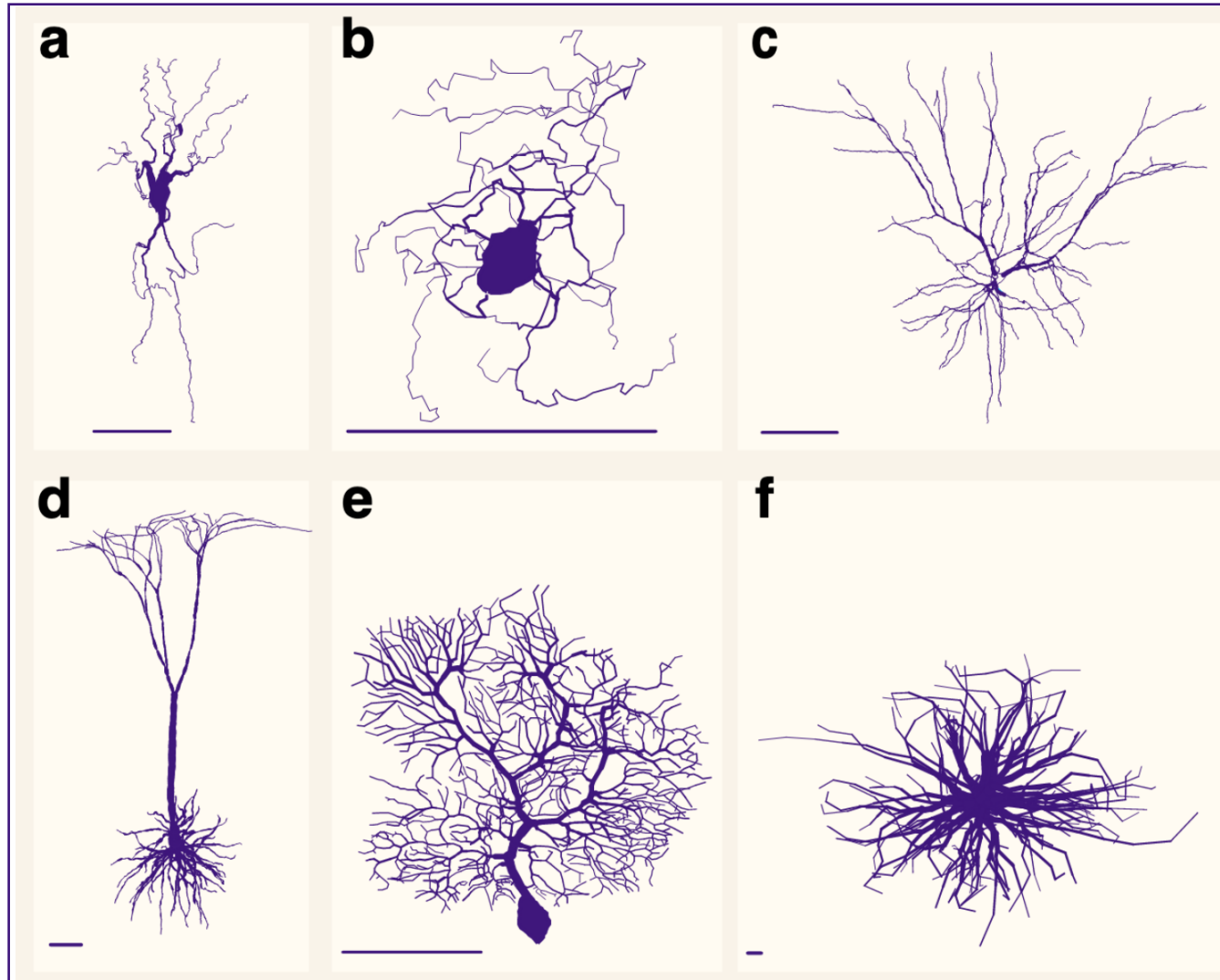

Biological view: dendrites offer a “computational toolkit”. [London et al 2005]

Neuromorphic view: Expressivity of dendrites allows single neurons to function as an ANN. [Poirazi & Mel, 2003; Beniaguev et al, 2021]

What inspiration should we draw from biology for neuromorphic/ artificial systems?

from Koch & Segev (2000) Nature 3: 1171

DENDRITES ARE NONLINEAR

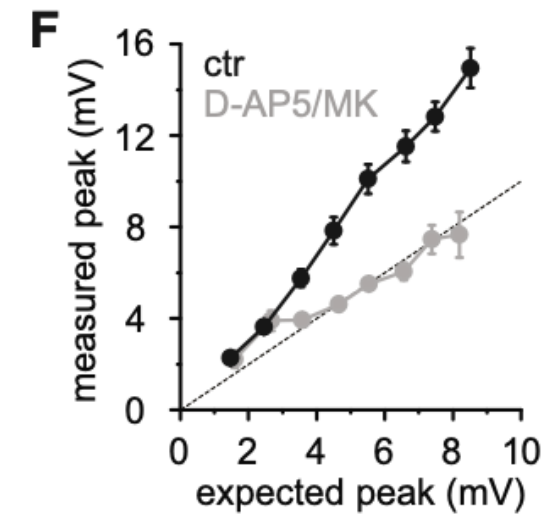
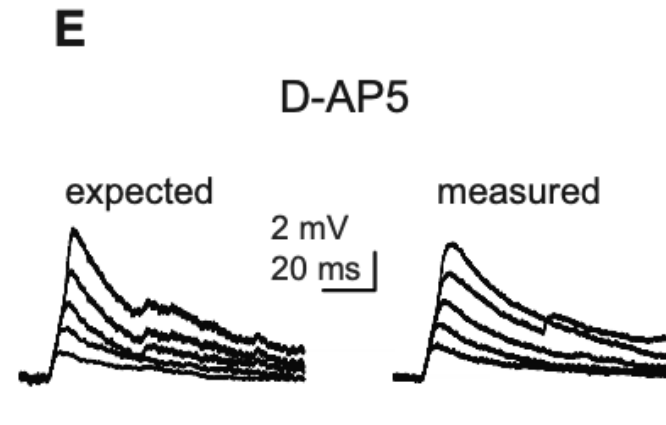
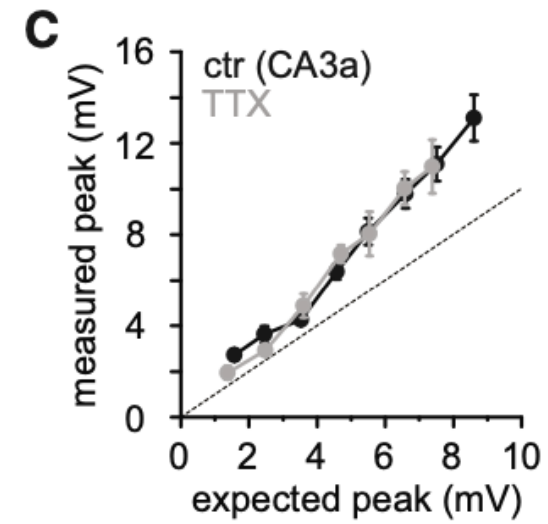
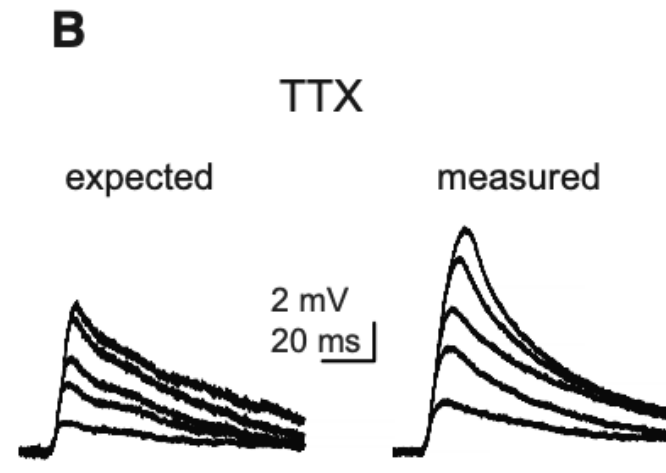
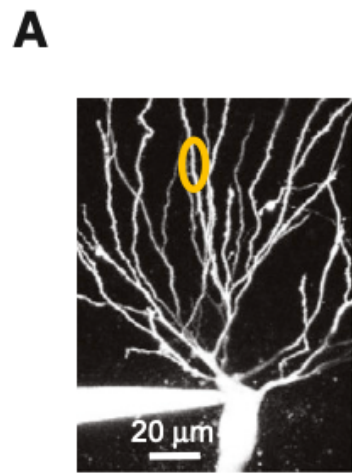

from Makara & Magee 2013

DIRECTION SELECTIVITY FROM SHUNTING IN A BIOLOGICAL DENDRITE

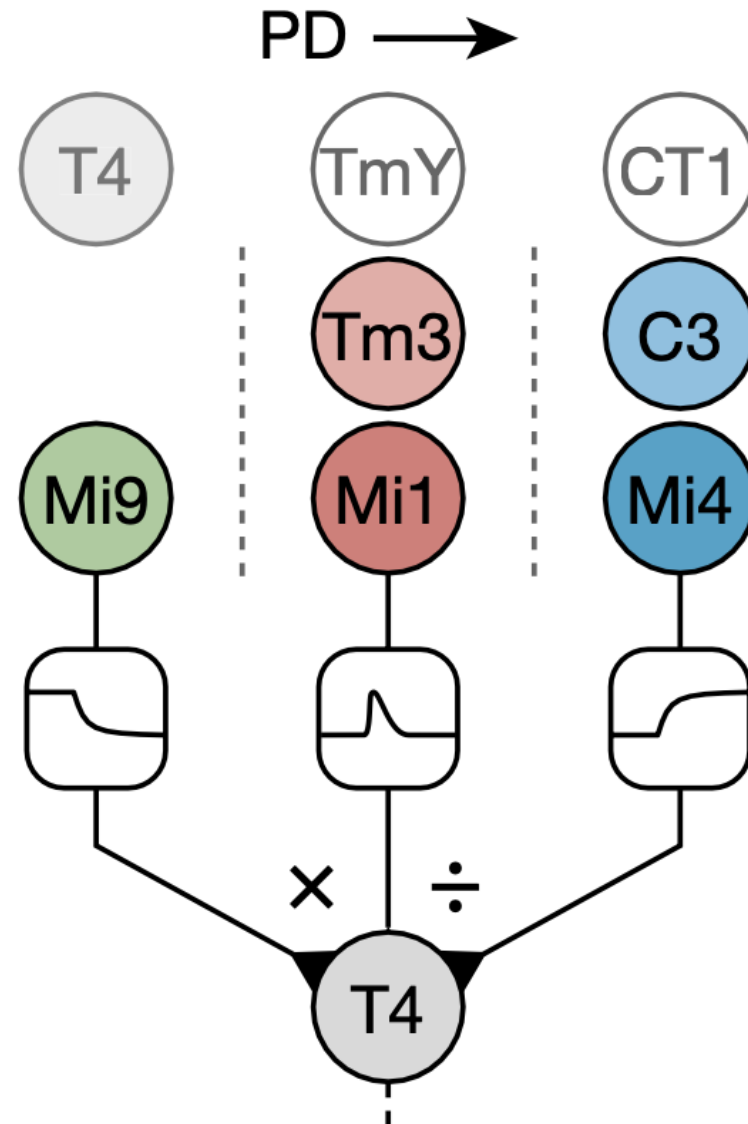
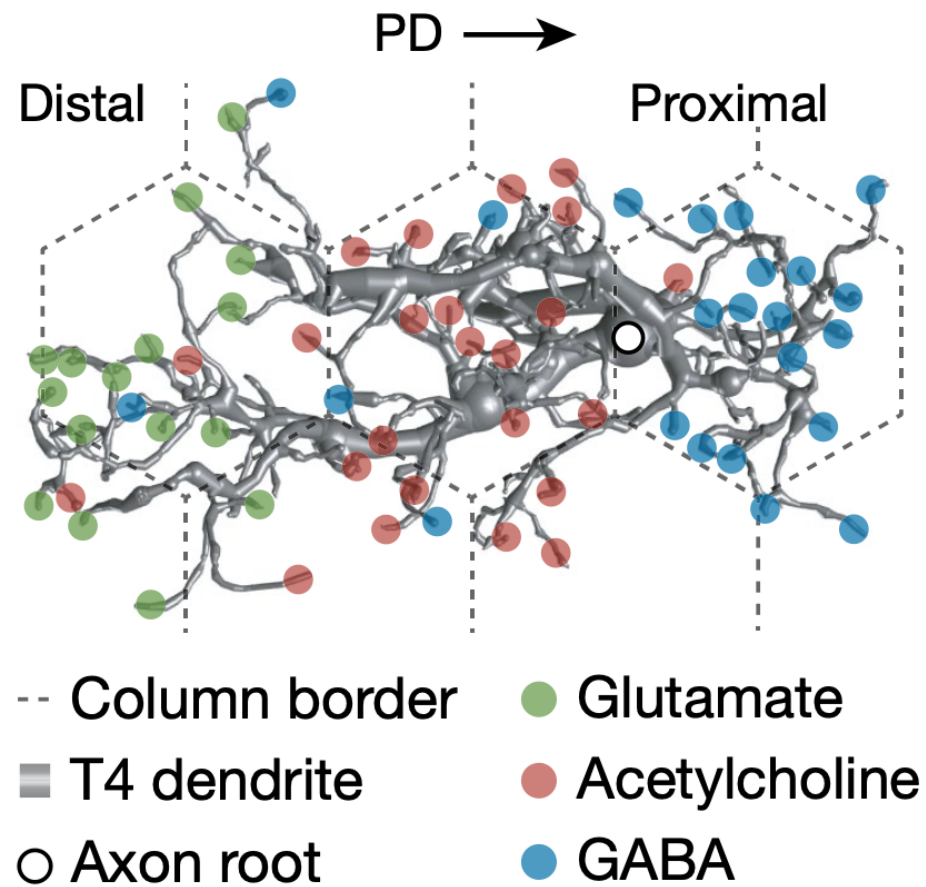

SHUNTING AS A GATE: COINCIDENCE DETECTION IN NUCLEUS LAMINARIS



Phase shift: 180°

