



Laser-plasma accelerator driven, compact quasi-monoenergetic photon sources

June 2021

Changing the World's Energy Future

Hai-En Tsai, David L Chichester, Scott J Thompson



DISCLAIMER

This information was prepared as an account of work sponsored by an agency of the U.S. Government. Neither the U.S. Government nor any agency thereof, nor any of their employees, makes any warranty, expressed or implied, or assumes any legal liability or responsibility for the accuracy, completeness, or usefulness, of any information, apparatus, product, or process disclosed, or represents that its use would not infringe privately owned rights. References herein to any specific commercial product, process, or service by trade name, trade mark, manufacturer, or otherwise, does not necessarily constitute or imply its endorsement, recommendation, or favoring by the U.S. Government or any agency thereof. The views and opinions of authors expressed herein do not necessarily state or reflect those of the U.S. Government or any agency thereof.

Laser-plasma accelerator driven, compact quasi-monoenergetic photon sources

Hai-En Tsai, David L Chichester, Scott J Thompson

June 2021

**Idaho National Laboratory
Idaho Falls, Idaho 83415**

<http://www.inl.gov>

**Prepared for the
U.S. Department of Energy
Under DOE Idaho Operations Office
Contract DE-AC07-05ID14517**

Laser-plasma accelerator driven, compact quasi-monoenergetic photon sources

Cameron Geddes,
Accelerator Technology & Applied Physics Division

Hai-En Tsai¹, Tobias Ostermayr¹, Liona Fan-Chiang¹, Robert Jacob¹, Jeroen van Tilborg¹, Sam Barber¹, Sahel Hakimi¹, Ocean Zhou¹, Fumika Isono¹, Carlo Benedetti¹, Remi Lehe¹, Jean-Luc Vay¹, Carl Schroeder¹, Bernhard A Ludewigt¹, John D Valentine¹, Brian J Quiter¹, Marie-Anne Descalle², Alex Friedman², David Grote², Glen Warren³, Scott Thompson⁴, David Chichester⁴, Cameron Miller⁵, Sara Pozzi⁵, Eric Esarey¹

¹Lawrence Berkeley National Laboratory, Berkeley, CA, USA

²Lawrence Livermore National Laboratory, ³Pacific Northwest National Laboratory

⁴Idaho National Laboratory, ⁵University of Michigan

Nuclear Photonics, Kurashiki Japan

9 June, 2021



ACCELERATOR TECHNOLOGY &
APPLIED PHYSICS DIVISION



U.S. DEPARTMENT OF
ENERGY

Office of
Science

Outline

- Plasma accelerators
- Mono-energetic photon applications
- Compact laser-plasma photon source
- kHz precision and application rates

BELLA Center

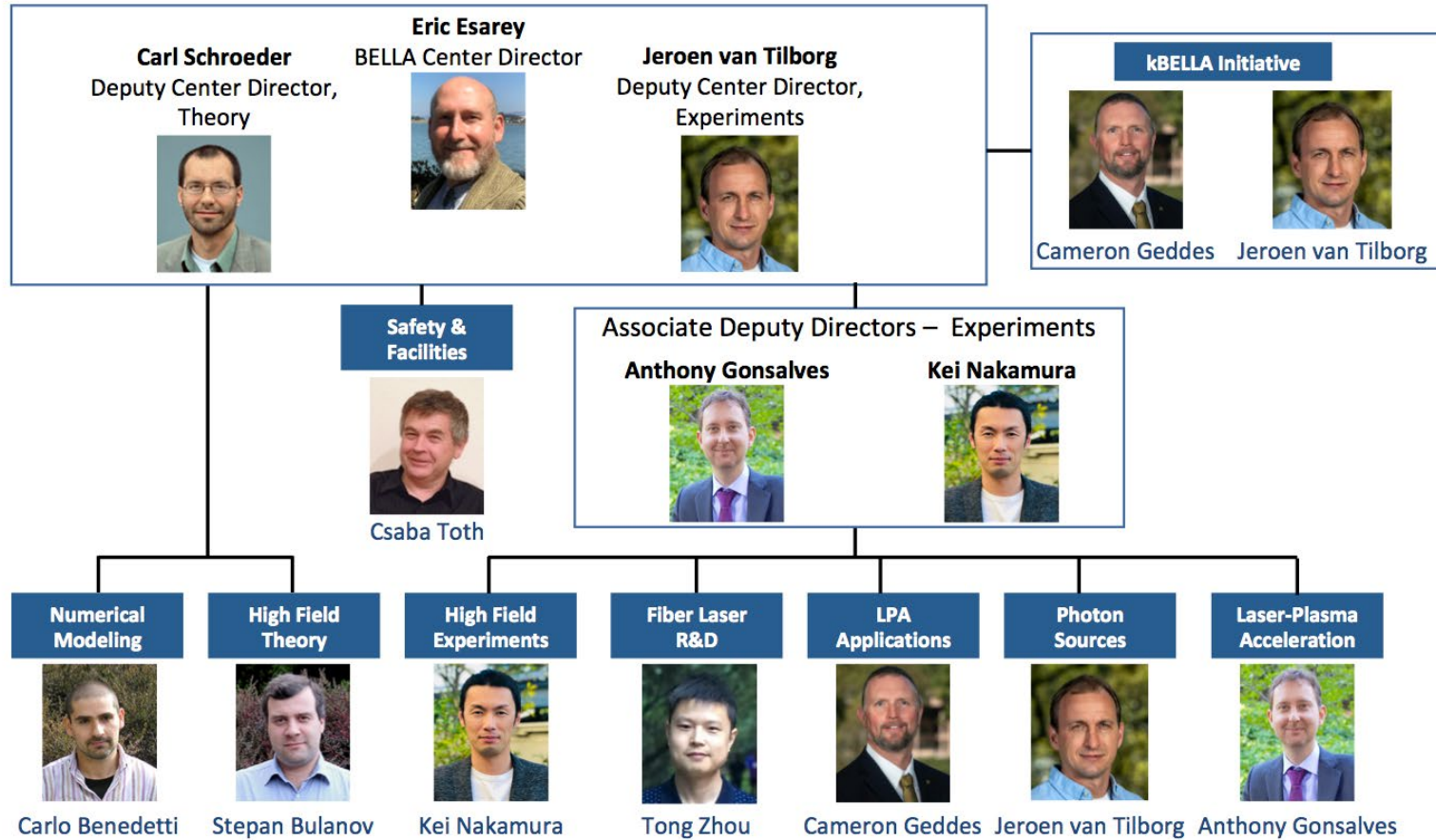

Engineering:
Zachary Eisentraut
Jonathan Bradford
Mark Kirkpatrick
Tyler Sipla
Arturo Magana
Joe Riley
Nathan Ybarrolaza
Greg Mannino
James Vuong

Additional: project staff
Haris Muratagic et al.

Postdocs, Research and Project Scientists

Sam Barber
Marlene Turner
Sahel Hakimi

Hai-En Tsai
Liselotte Obst-Huebl
Hao Ding
Tobias Ostermayr

Doctoral Students

Robert Jacob
Fumika Isono

Liona Fan-Chiang
Chris Pieronek

Close links: ATAP Accelerator Modeling (AMP) and Controls & Instrumentation (BACI) programs

Engineering, including project teams

Ultrahigh Fields (>10 GV/m) Enable Compact Accelerators & Unique States

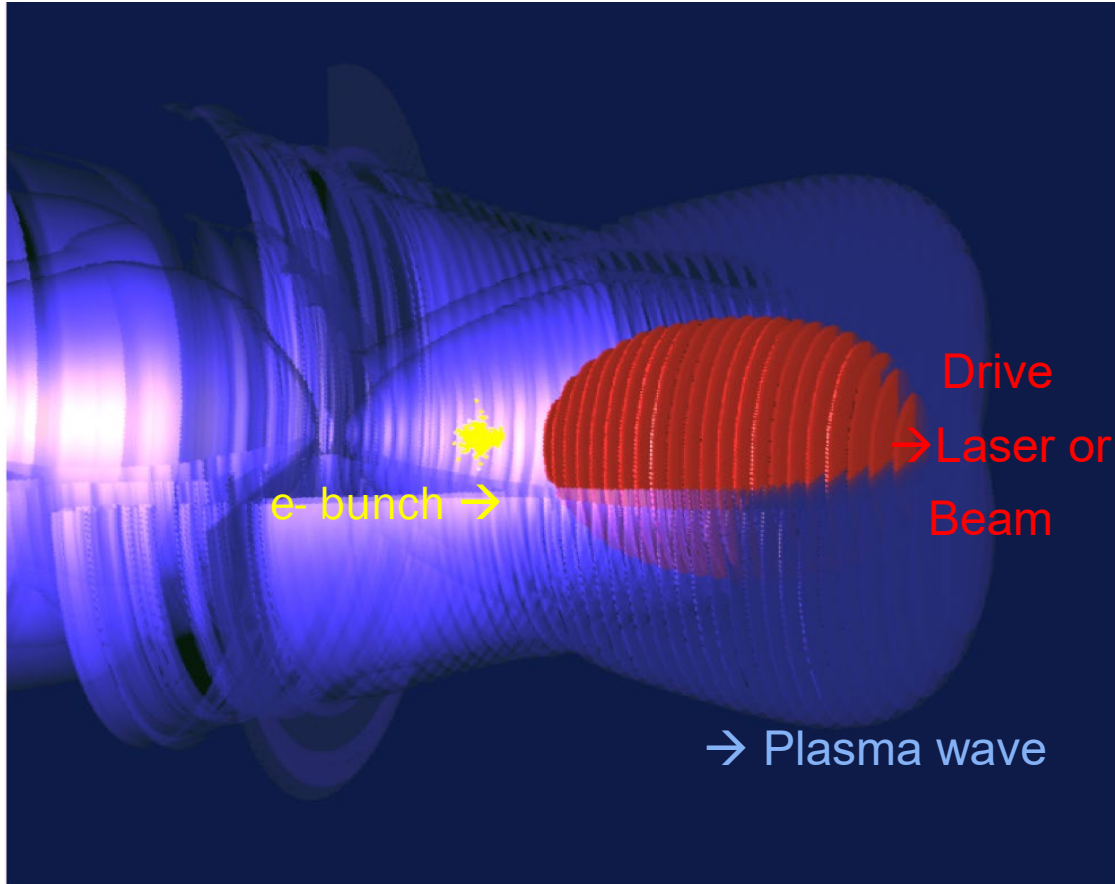

2019: 8 GeV record

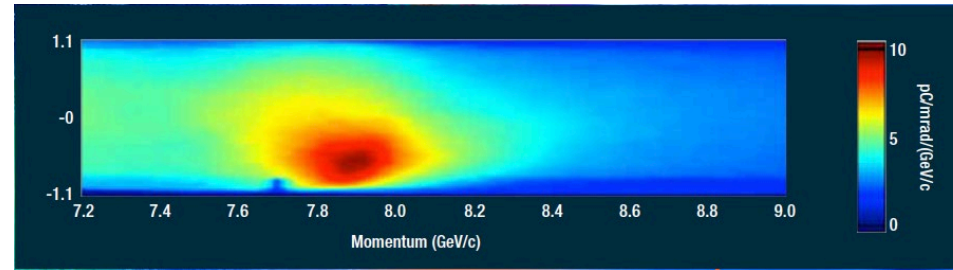

Gonsalves et al., PRL 2019



in a 20 cm plasma



vs. 300-500m conventional



BELLA Experimental Facilities: World-Leading Capabilities Driving LPA Technology for High Energy Physics and Applications

Existing and planned laser facilities in Building 71 at LBNL

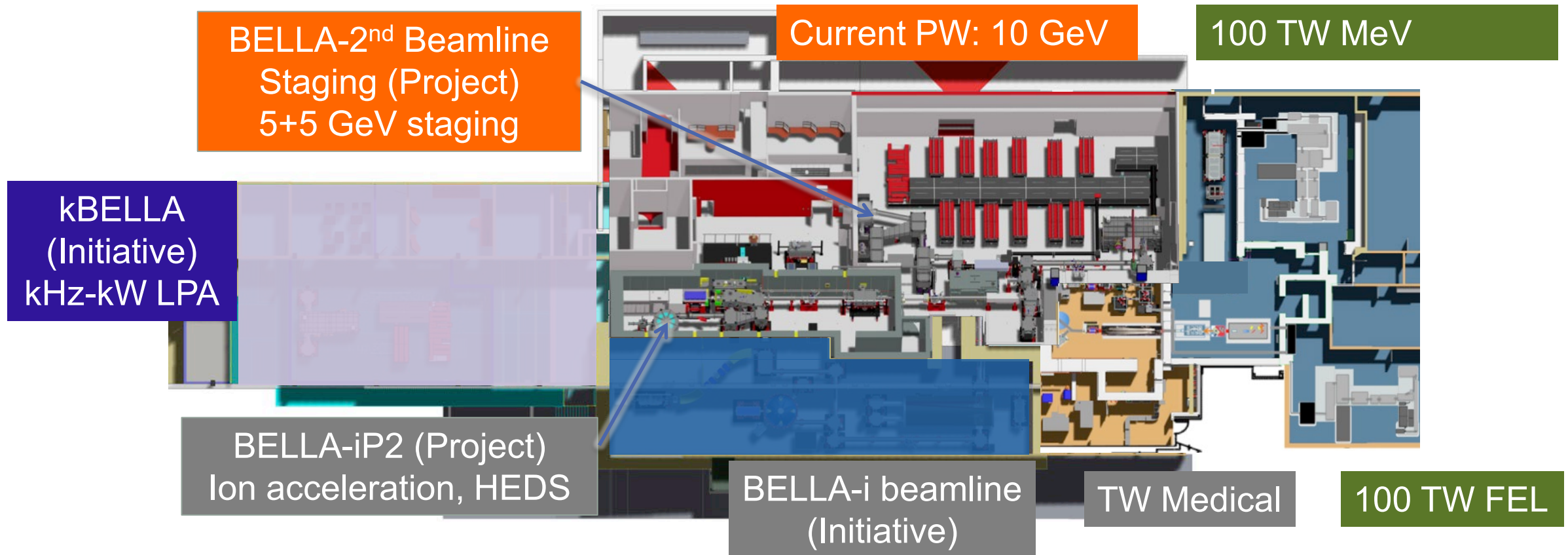

Unique resource of and for the DOE and beyond
State of the art: 1 Hz at PW, 5 Hz at 100 TW



Office of
Science

Outline

- Plasma accelerators
- **Mono-energetic photon applications**
- Compact laser-plasma photon source
- kHz precision and application rates

Reduce dose and increase sensitivity by order(s) of magnitude in targets impenetrable to passive methods

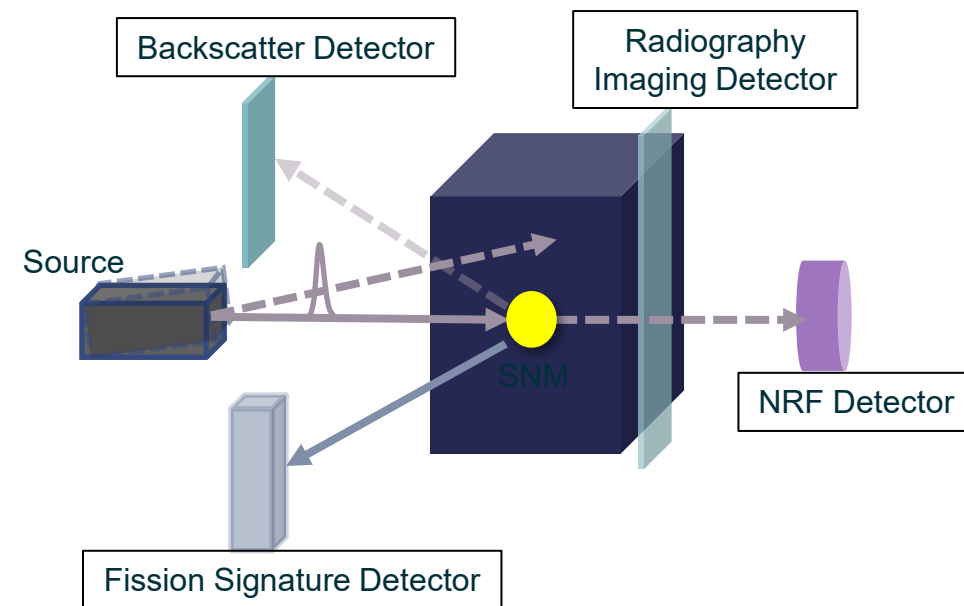
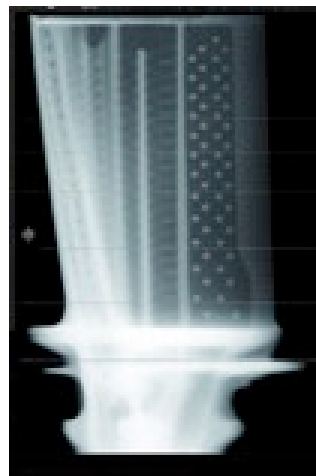
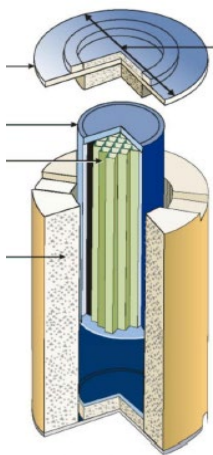

Increase resolution to μm & fs, 3D without CT...

Transform NDE, security, nonproliferation, medicine...

Requires compact/transportable systems

Monenergetic photon beams of narrow divergence angle enable high performance radiography + Z

- Select energy to reduce dose/increase contrast, 1-9 MeV
 - Energy spread at 20% level adequate
 - Dose reduced 2x-4x
 - Related: reduce hardening
- Multiple energies: 10x Z contrast
- Attenuation sets photons per 'pixel'
 - 40 cm steel $\sim 10^{-5}$ -> order 10^8 photons
- Milliradian 'pencil' beam mitigates scattering, penetrated thick objects
 - Dose reduced 10x-100x
- Small emission spot: μm spatial resolution
- Requires tunable, high rate source
 - mrad divergence \sim cm spot
 - 20kHz pulse rate for container at 80cm/sec

Energy & Z Dependence of Mass Attenuation

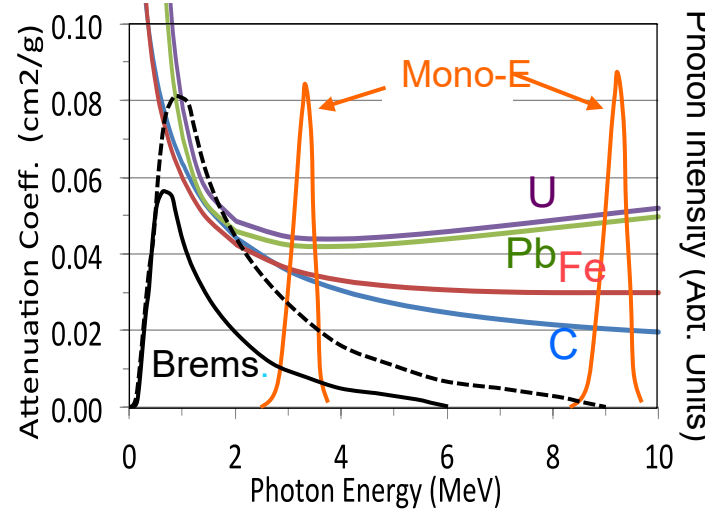

MPS dual energy ratio increases contrast

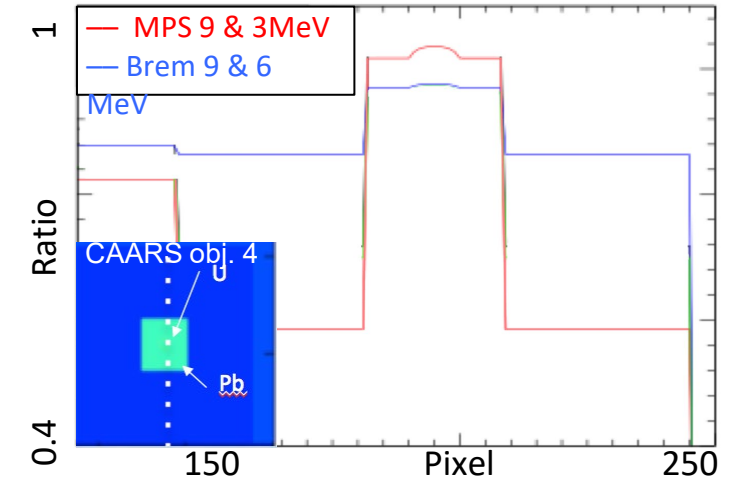

Narrow divergence penetrates thick objects

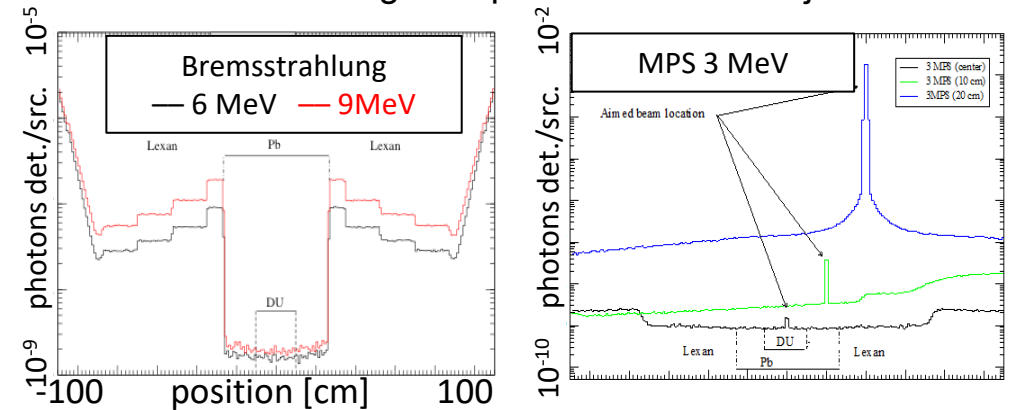

Mono-energetic beams enable new capabilities

Cask re-verification, determination of absence

- Re-verification of cask content (missing bundles)
 - Scattering, background and attenuation severe
- Pulsed, narrow divergence source can verify
 - 3×10^8 ph/pulse, 1 kHz, 10^{-8} transmission: 3000 ph/s
 - Missing single pin detectable longitudinally

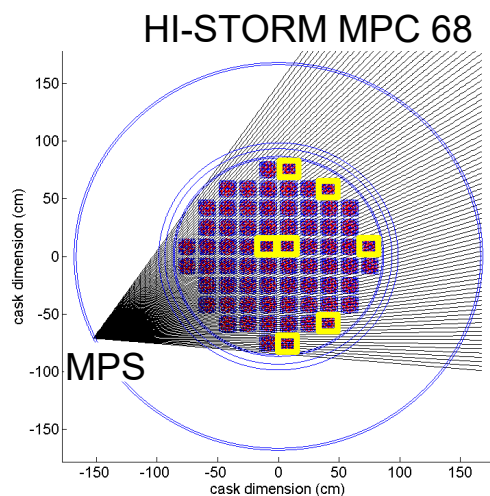
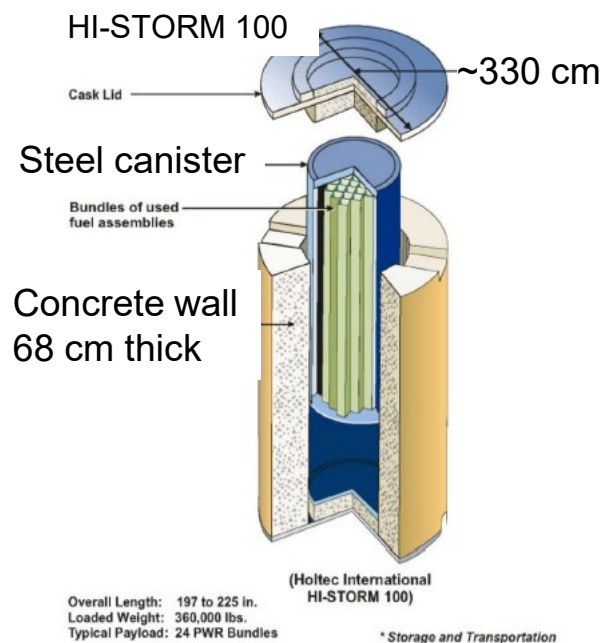

- Determination of presence/absence of fissile material
 - Photofission signature using mono-energetic beam enables powerful prompt neutron signature
 - Narrow divergence isolates object of interest
 - 3×10^8 ph/pulse, 10 kHz – inspection obj. determination in 30cm of SSTL or composite Pb/BPE in 300sec

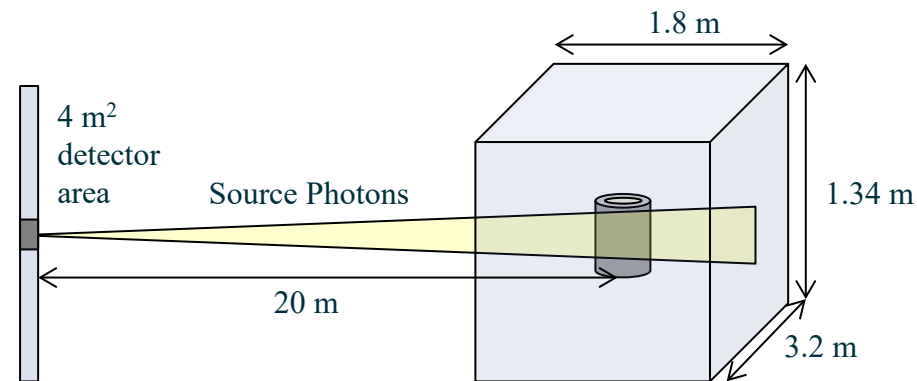

Mono-energetic beam properties enable nuclear resonance, new signatures

- $\Delta E_\gamma \leq \text{few } \%$: isolate NRF line using energy resolved detectors
 - $\Delta E_\gamma \leq 1 \%$: calorimetric detection
 - Dose proportional to ΔE_γ
- 2% energy spread at 10^7 ph/shot and kHz rates
 - 2kG HEU thru 10 cm steel in minutes, one detector
 - Few seconds at 10 kHz, 0.2% energy spread, 24 det.

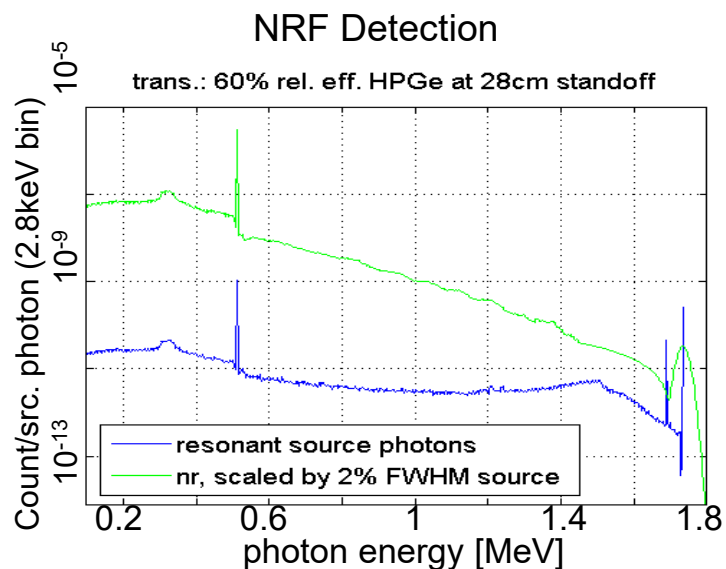

Brian Quiter

- Polarized photofission accesses isotopics

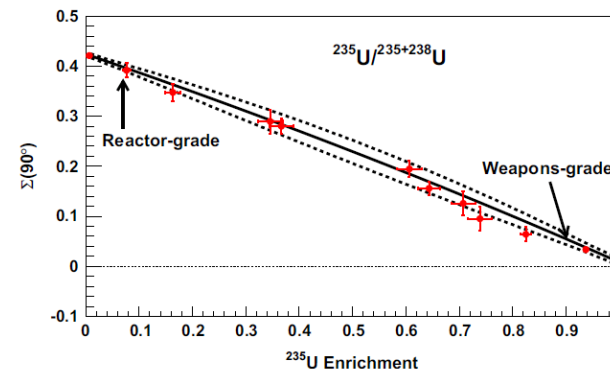

J. M. Mueller et al., Nuclear Instruments and Methods in Physics Research A 776 (2015)107–113

- Short pulse enables 3D backscatter time of flight

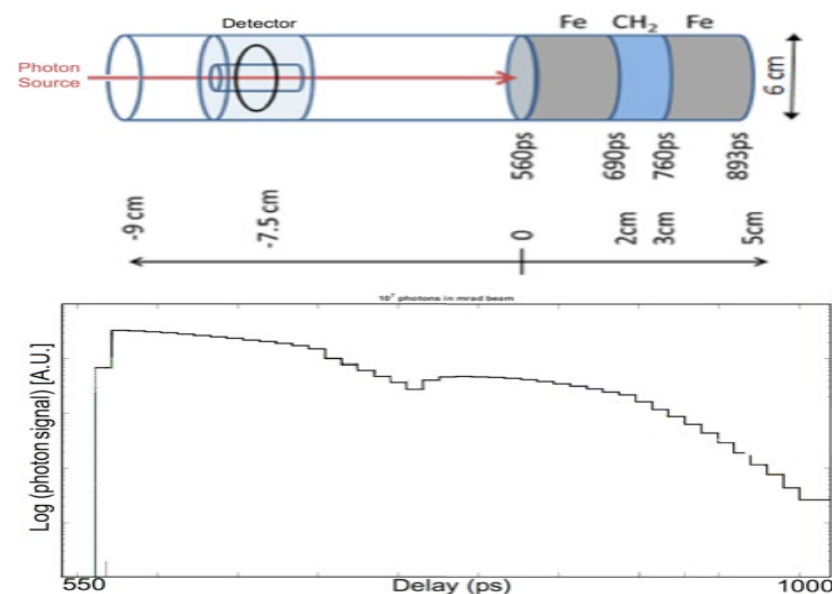

Outline

- Plasma accelerators
- Mono-energetic photon applications
- **Compact laser-plasma photon source**
- kHz precision and application rates

Thomson/Compton scattering source: Desirable photon properties, not conventionally compact

- MeV photons produced by scattering a laser from a relativistic electron beam¹
- Desirable source properties:
 - Low energy spread: enhanced signal, low dose
 - Tunable energy: Z, Photofission, and NRF
 - mrad divergence: mitigate scattering, adapt dose
 - Short-duration pulsed beam: 3D, background
 - Small emission spot size (μm): spatial resolution
 - Adjustable per-shot: flux, energy, polarization
- Proven on fixed facilities, used for nuclear signature development

**Key problem for applications use is electron accelerator requirement:
~0.5 GeV + high current + shielding**

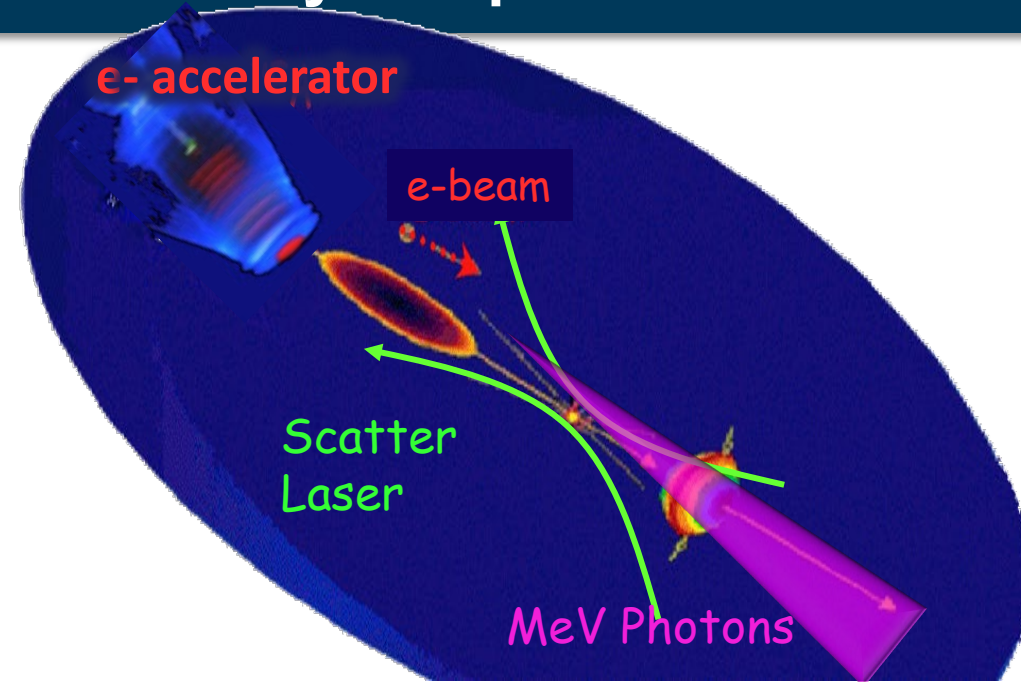

Move from large facilities
to compact systems

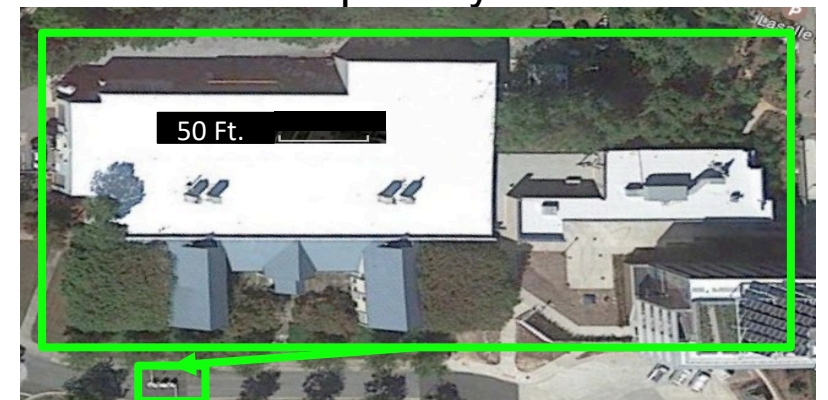

Compact source development path integrates: acceleration, scattering and disposal

Requirement & gap

High-energy, high quality e-beam at 0.2-0.6 GeV required

- Conventionally, long accelerator

High flux photon production limited by scattering laser diffraction and nonlinearity

- High current or large scattering laser required – large facility

Shielding requirement increases with energy and current

- Conventionally, many tons

Approach

High quality cm-scale LPA demonstrated in experiments

- Meets photon source requirements: energy, energy spread, divergence

Techniques to increase photon yield simulated: reduce current and scattering laser requirements

- Scatter pulse length, guiding in plasma channel (like LPA), pulse shaping

Deceleration of electrons by LPA: proof-of-concept experiment

- Reduce shielding by reducing e- energy

Current Project: Integrated prototype to demonstrate key per-shot elements

Use existing lasers at 5Hz repetition rate

Establish path to high flux, kHz, low energy spread

Integrated experiment to demonstrate, laser-plasma driven, compact photon system concept

- Build and test concept for a compact source

- Electron beam produced by compact cm-scale laser plasma accelerator (LPA)
- Produce 1-9 MeV photons
- Increase photon production: control scattering laser length & focusing
- Reduce shielding: decelerate electrons after scattering

- Dual-Arm laser allows independent control of accelerator, scattering

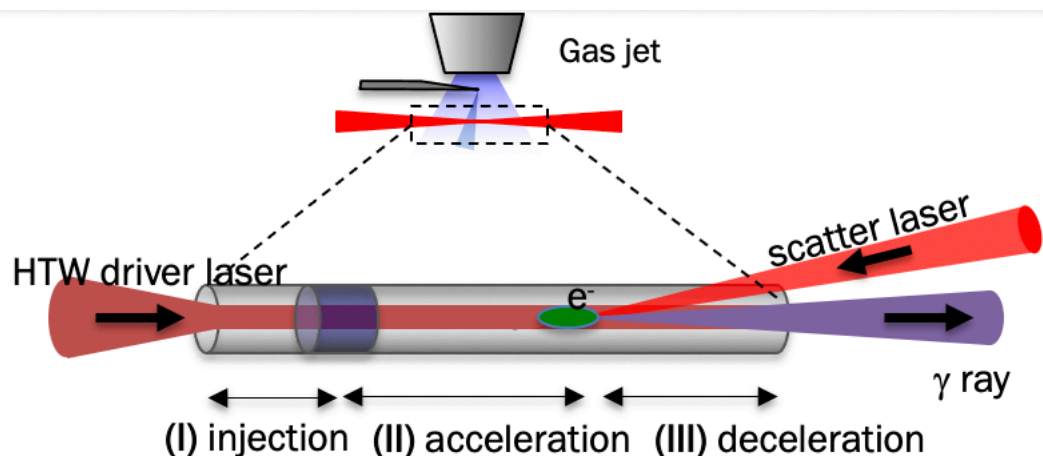

Dedicated facility in existing cave

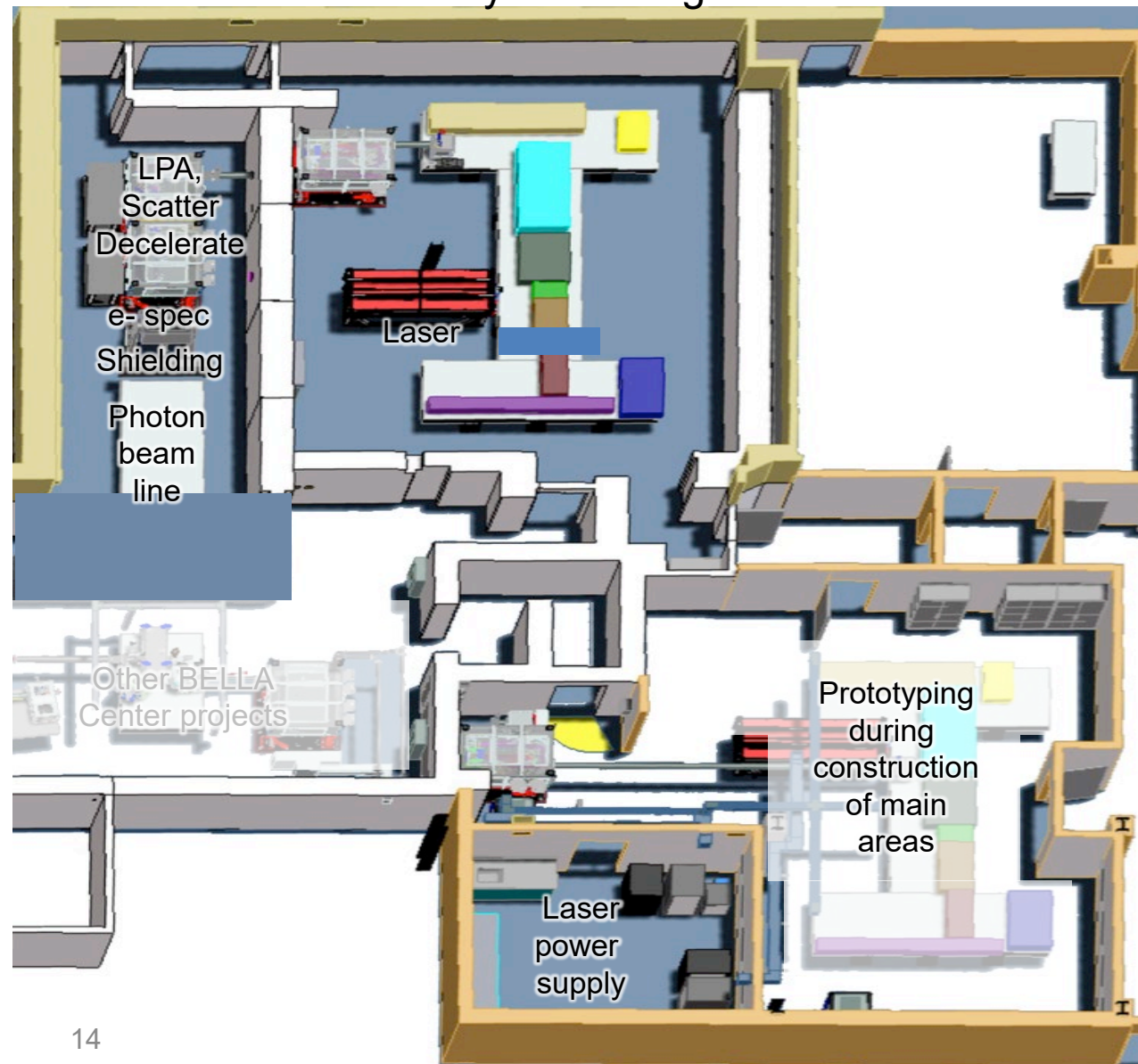

Laser delivering stable source

High quality drive focus

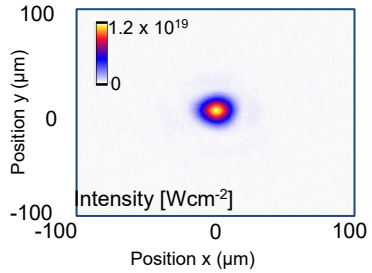

High quality scatter focus

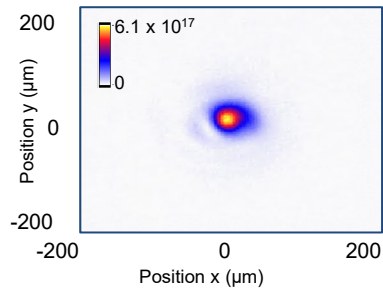

40 fs pulse

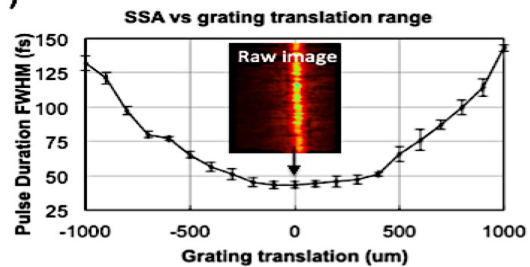

Energy stability

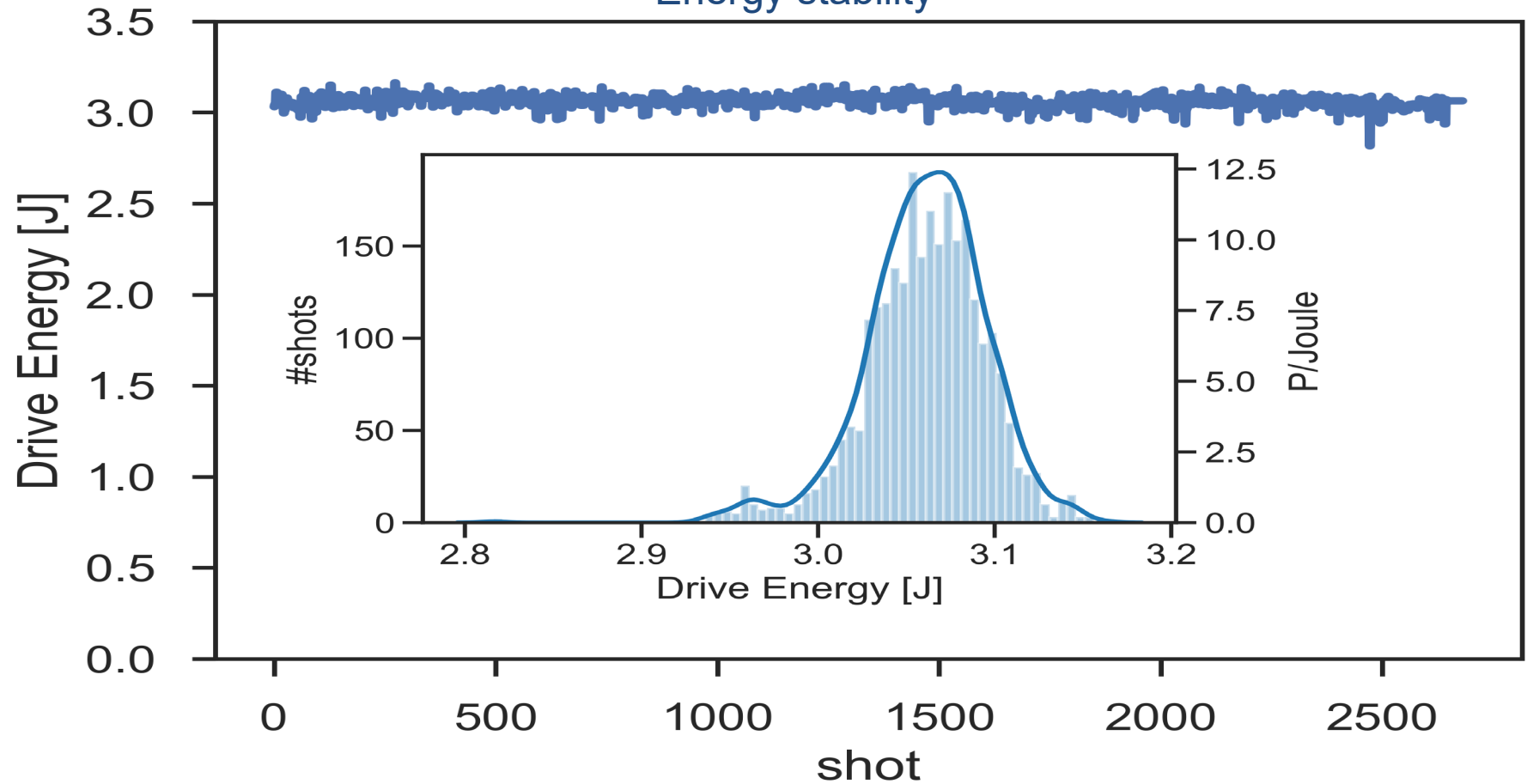

Hundred TW Thomson Experimental Setup

Experimental Setup

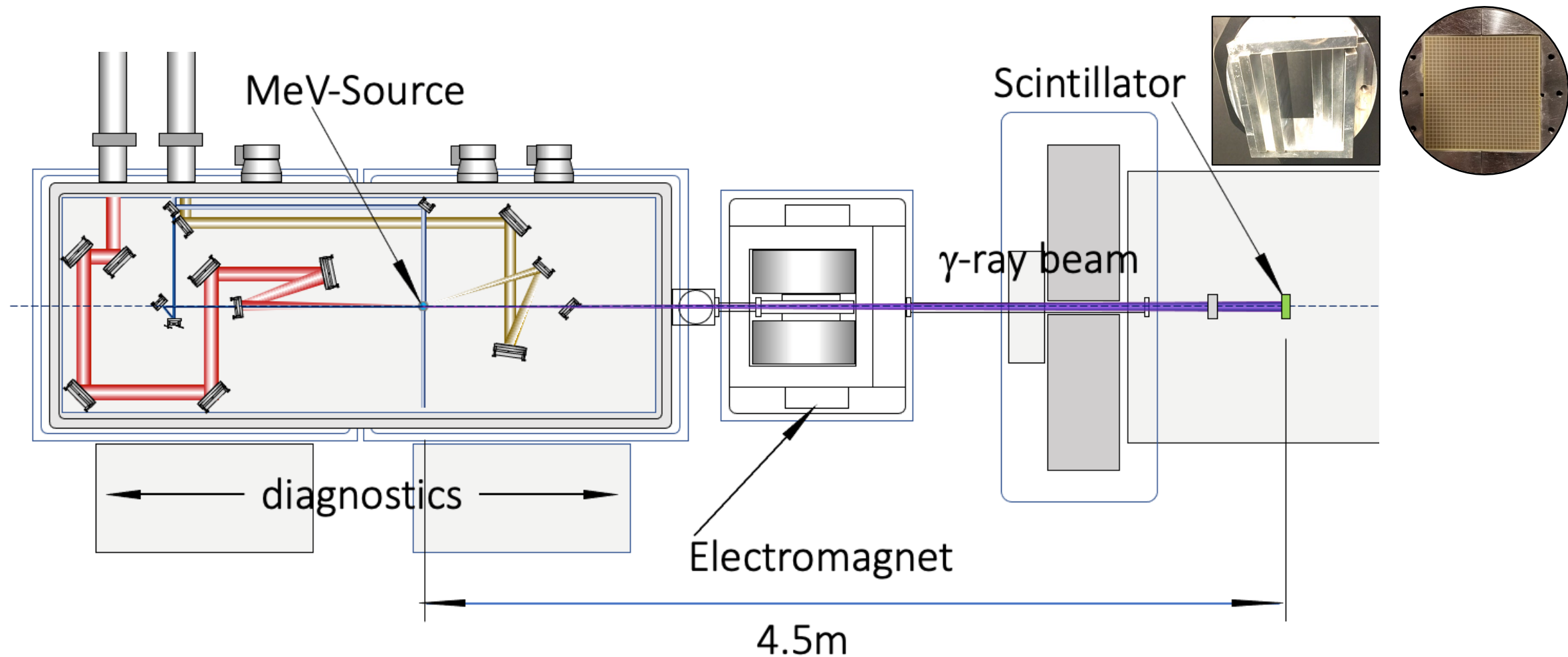

LPA stable and tunable in energy Scattering system alignment developed

Stable electron beam, repeatable over days of operation

133 MeV mean – initial regime

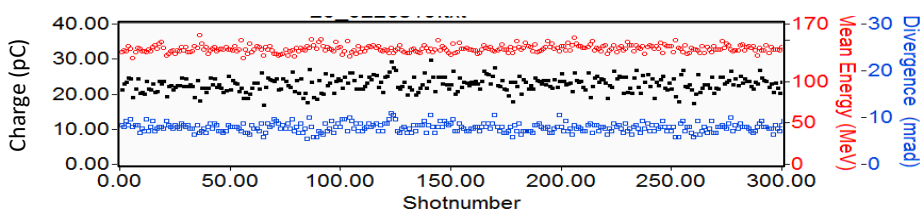
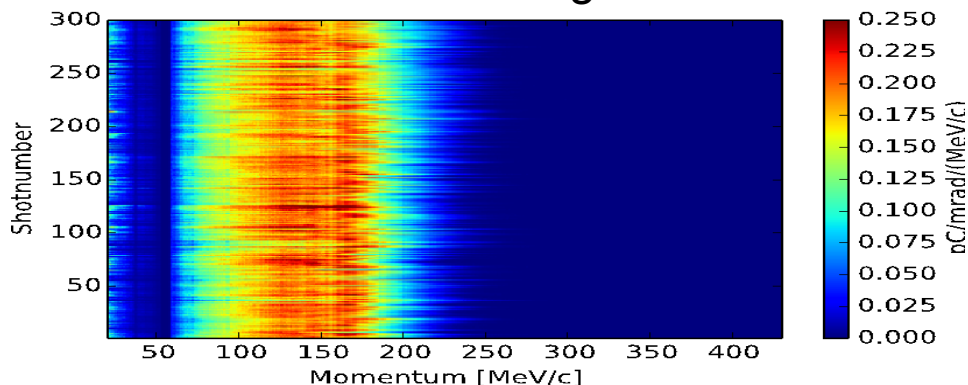

Energy tunable, e.g. 200MeV

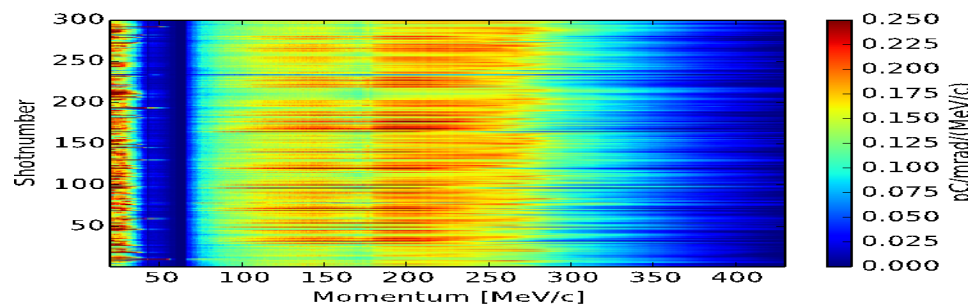

Photon production alignment Precise and deterministic

Top view imager: overlap scatter Horizontal
plane + Timing

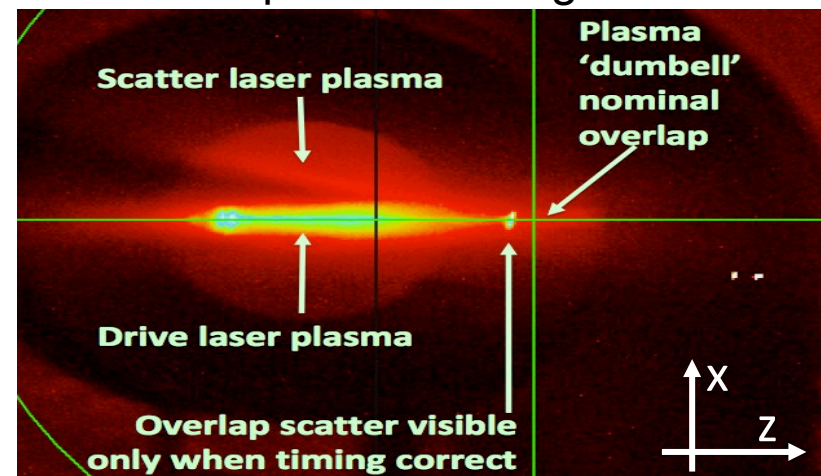

Side view shadowgram: shock
Vertical Plane + Timing

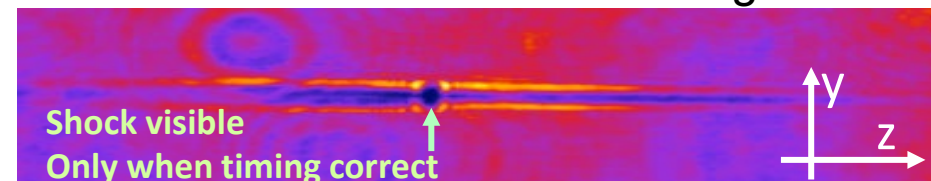

Sets condition for photon production

Photon source operating reproducibly Beam flux at target level using scatter laser

Photon beams produced,
repeatable

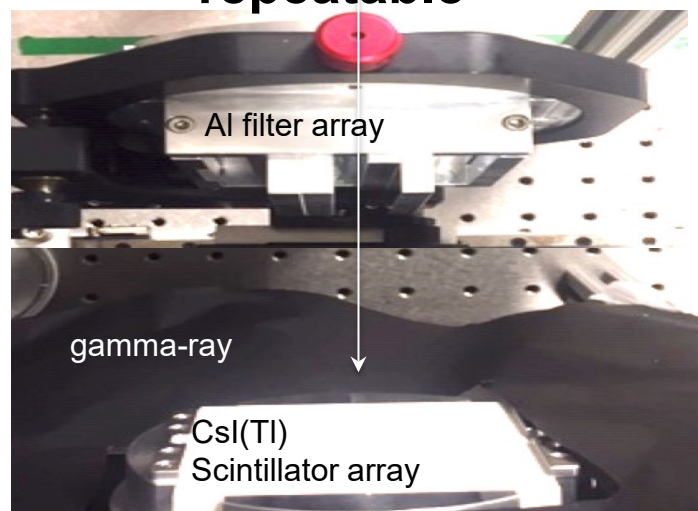

Photon beam on scintillator

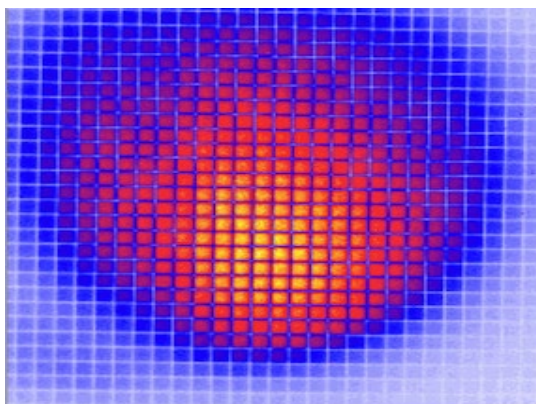

Photon yield $2e7$ /shot
using independent laser:

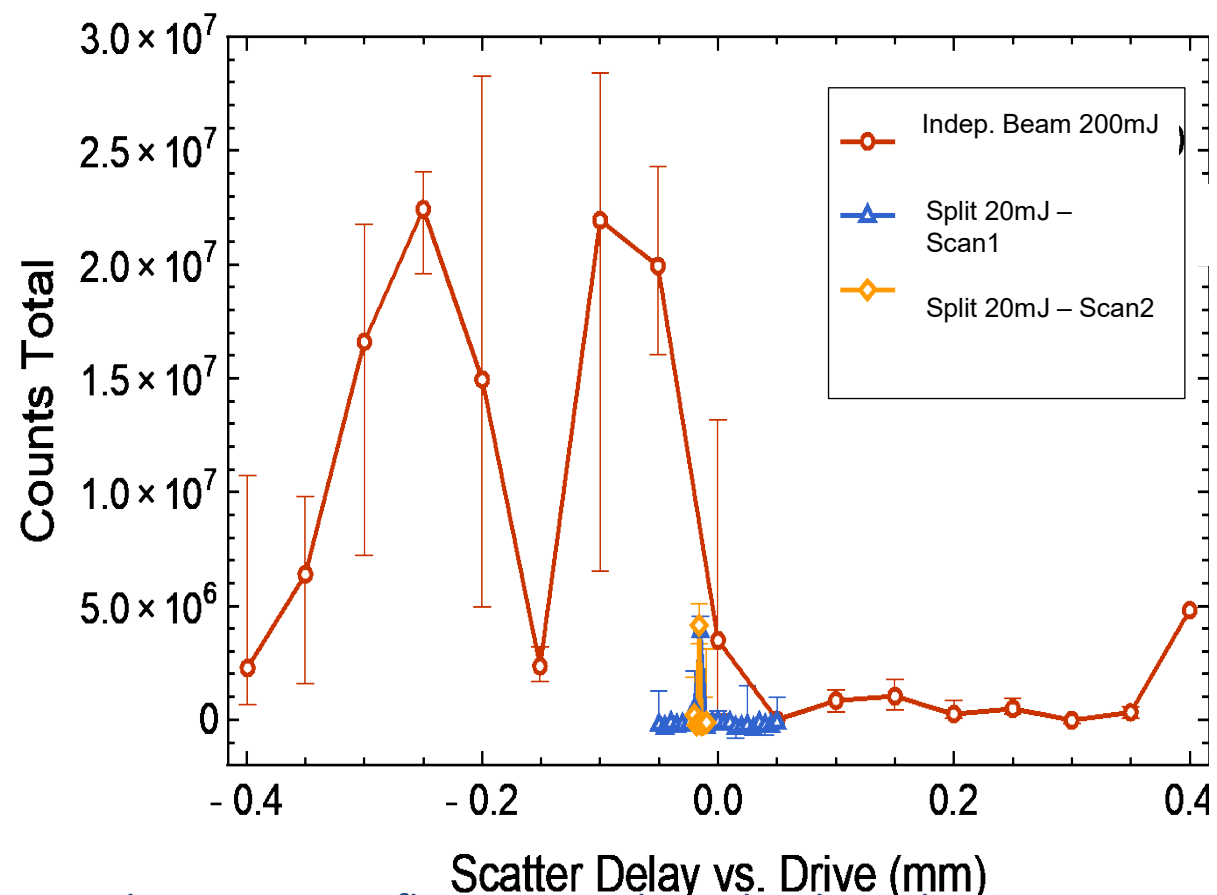

Photon source fluctuations based only on laser pointing $\sim 50\%$
RMS – can be stabilized

MeV photons produced Energies < 1 MeV to 9 MeV accessible with LPA

**Photon energy & flux
Measured using scintillator**

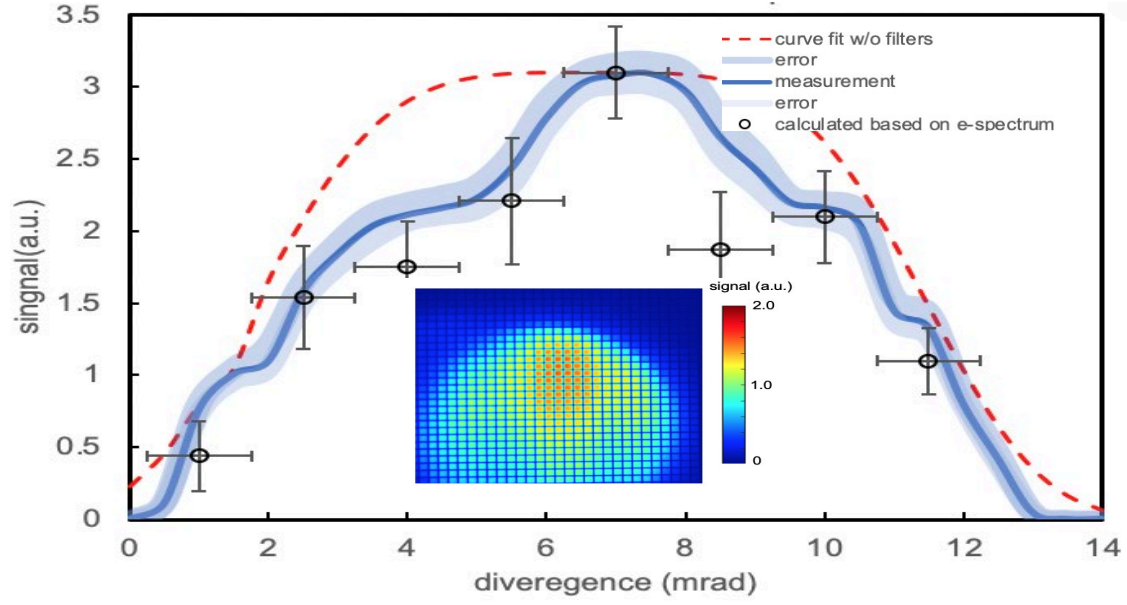

**Next: 1-9 MeV photons using
Controlled electron injection**

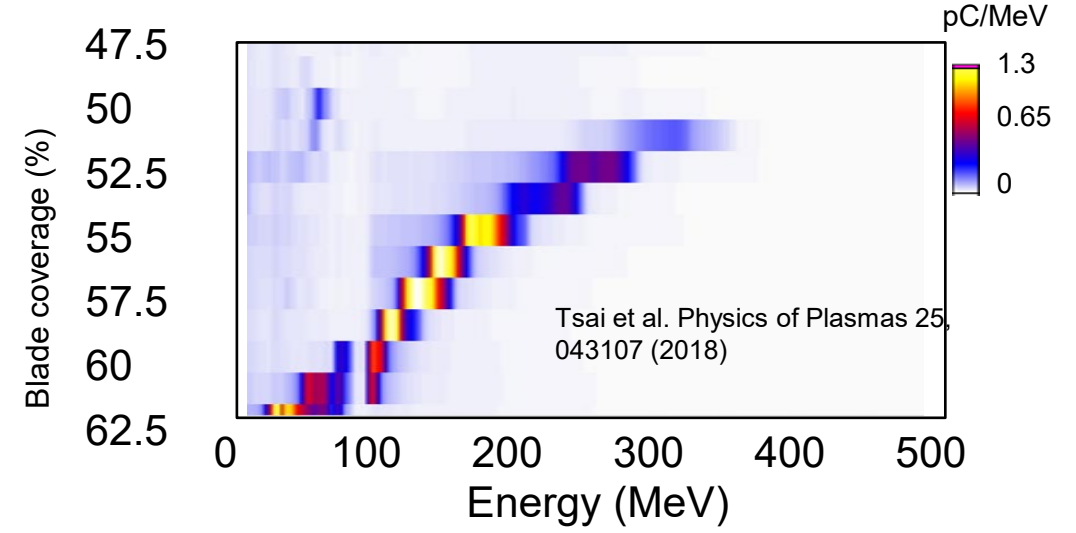

- Photon energy extracted from filter transmission = 0.45 MeV
close to scatter theory, $E_{\text{gamma}} = 4\gamma^2 E_{\text{laserphoton}} = 0.41 \text{ MeV}$
- Photon yield (scintillator) $> 10^7$, using independent scatter laser
 - 5x improvement over initial photon yield $\sim 2 \times 10^6$, using split scatter beam
- Central energies up to 1.5 MeV to date, photons produced to 3 MeV
→ Next: 9 MeV photons from 600 MeV e-

Deceleration of electrons: proof-of principle experiment shows potential to reduce undesired bremsstrahlung & beam dump size

- Key to practical Thomson/Compton photon source

- 0.3 -0.6 GeV electron beam required
- Decelerate to reduce undesired bremsstrahlung from beam stop¹

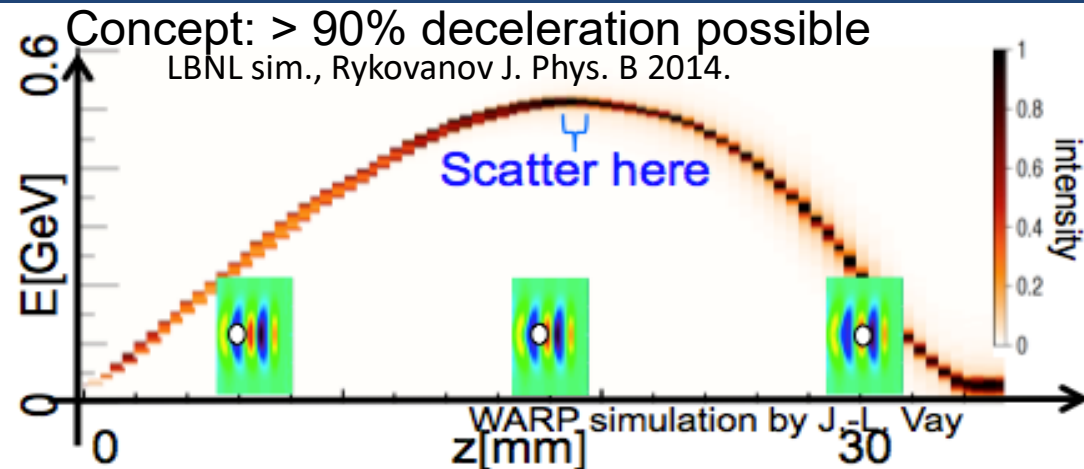

Use of two separate plasmas allowed control of phase for precise measurement

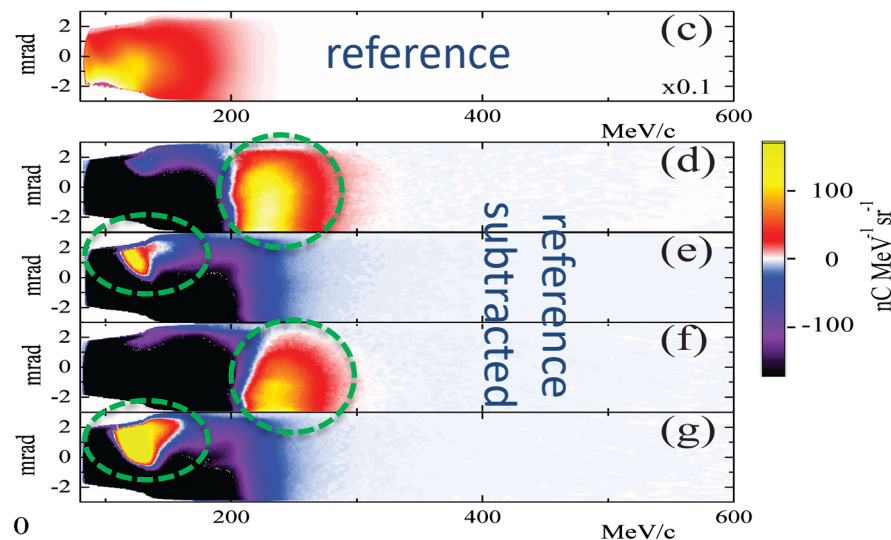
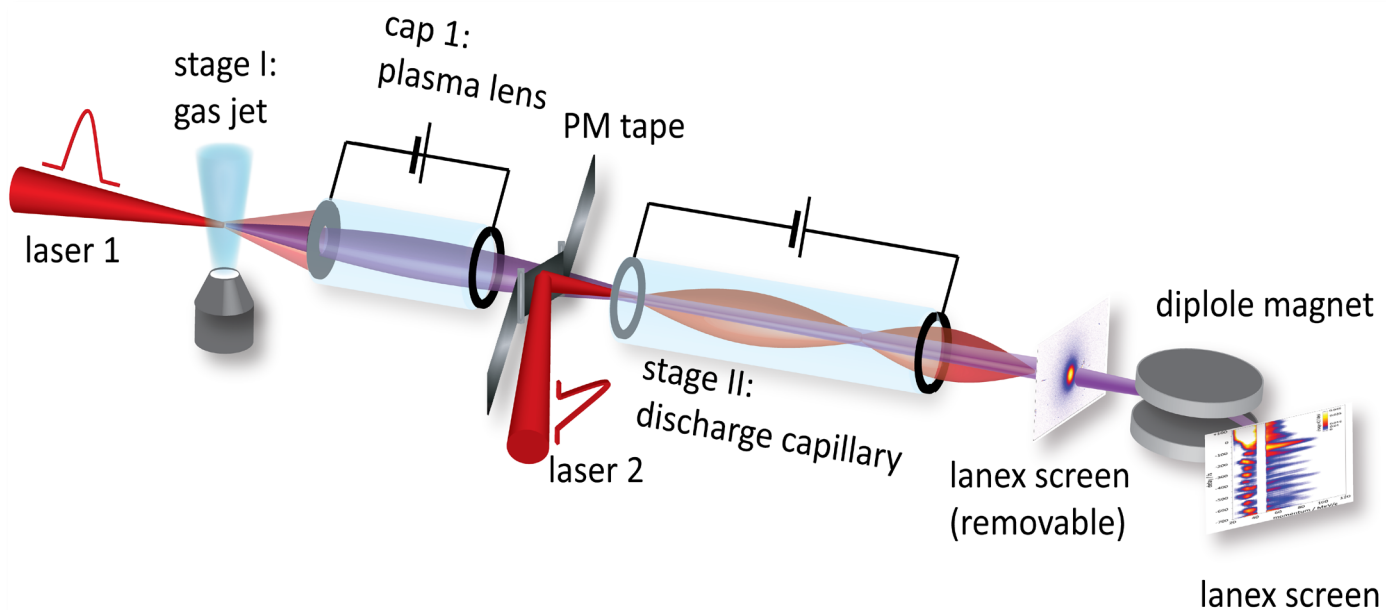

Next: implementation in photon source experiment, using single plasma

Path to high performance photon sources via LPA development

ΔE_{ph} limited by electron quality: $div_e, \Delta E_e$

Demonstrated LPAs allow $\Delta E_{ph} \sim 10\%$

- Electron emittance dominates ΔE_{ph}

Demonstrated 1% ΔE_e allows $\Delta E_{ph} \sim 2\%$

- Experiments indicate potential for $<1\%$
- e-beam refocusing or emittance reduction to reduce divergence

Next steps: precision laser control to increase performance

- Fast laser pointing to control beam intersection
- Deformable optics to improve accelerator structure
- Laser shaping to increase efficiency, path to smaller systems

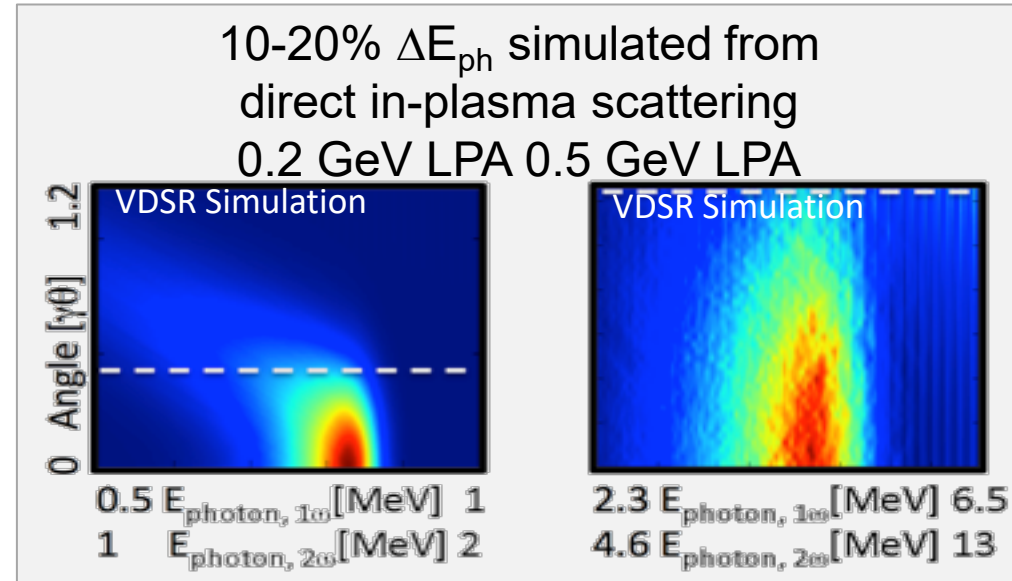

Percent-level ΔE_{ph} with divergence control

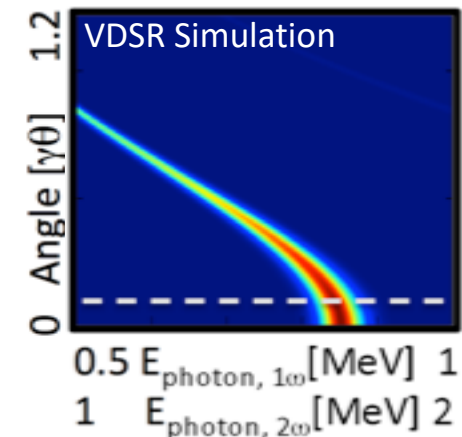

Outline

- Plasma accelerators
- Mono-energetic photon applications
- Compact laser-plasma photon source
- kHz precision and application rates

Science Need: kHz Key to Efficient, High Quality Accelerators & Ultrafast Science

Laser plasma accelerator potential shown

- Order of magnitude performance increase needed for HEP and applications
- Theory & simulation show attainable



Realizing potential requires precision

Broad ultrafast science potential

- HEDS precision time resolved tomography over thousands of shots
- Attoscience, Molecular Dynamics, Sensing, Nuclear Science, Radiation biology
- Sources for Bioimaging, COVID, Microelectronics, HEP detectors,
- Applications limited by rate & performance

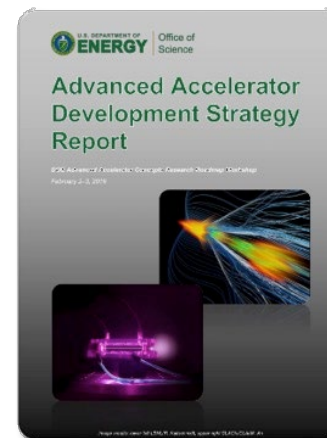
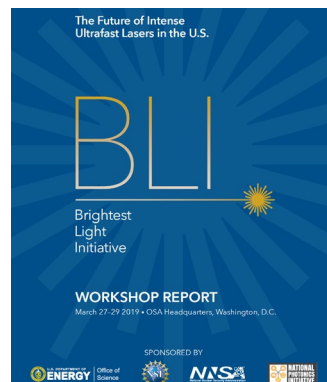

Realizing potential requires rate

Increasing laser energy only does not enable applications – not efficient

Precision laser shaping and control required for quality and efficiency

- Laser pointing: from μrad to $< 0.1 \mu\text{rad}$
- Focal spot/wave front: now at fluctuation limit
- Near field: currently not well controlled
- Pulse shape, carrier envelope phase...

Ground & air motion fall off at $O[100\text{Hz}]$

Correction at kHz >10 fold - key to LPA performance
PW target chamber vibration in vacuum



BELLA mJ kHz: 10x reduced pointing fluctuation
Other groups: CEP, spectral phase...

Laser Control and Stabilization for Precision LPA on Existing Lasers

kHz-mJ regen pilot beam to characterize 100TW system

- Wedged steering mirror: 'copy' of pulse
- Position and angle on target in both planes

Pilot well correlated to amplified pulse

- Diagnostics: non-perturbative at high-power
- Correction to be enabled at kHz – potential 10x improved pointing
- Path to correction of other parameters

Does not correct: pumping & beam size effects

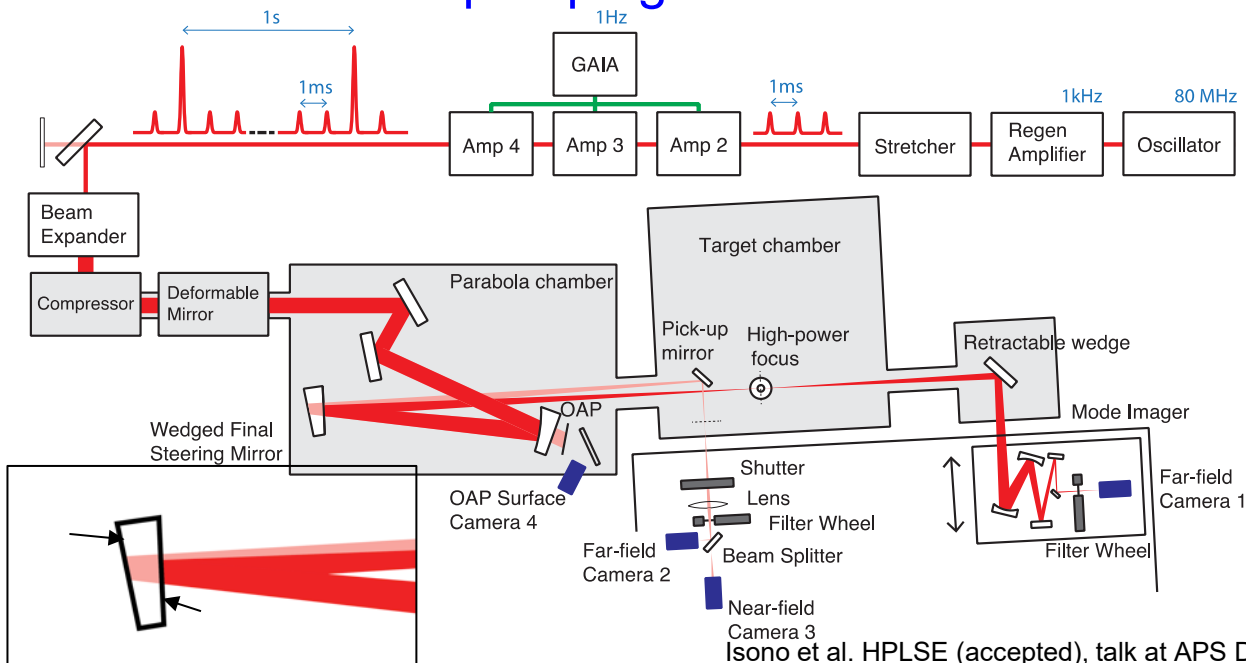

Pilot well correlated to amplified beam

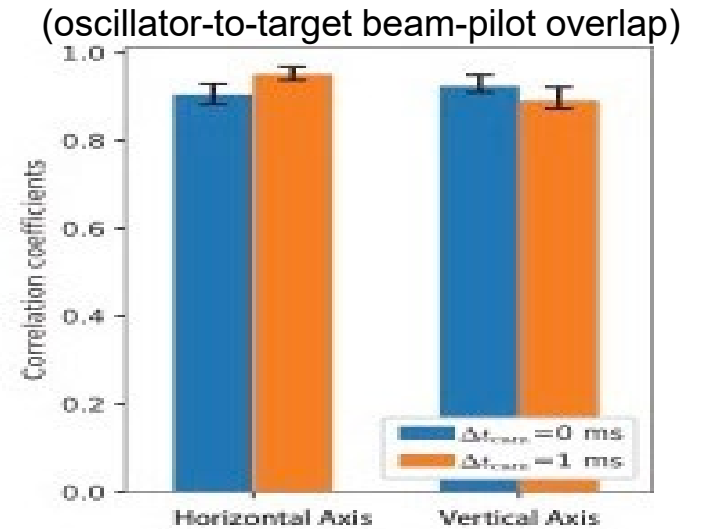

Fluctuation primarily < 100 Hz

FFT Position Hor.—, Vert. —

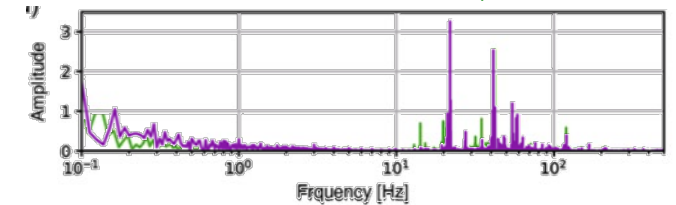

FFT Angle Hor.—, Vert. —

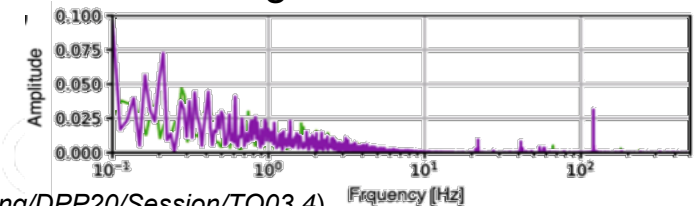

Ti:sapphire kHz Design Ready to Build

Ti:sapphire – extend existing systems

Near term 3J / GeV LPA available

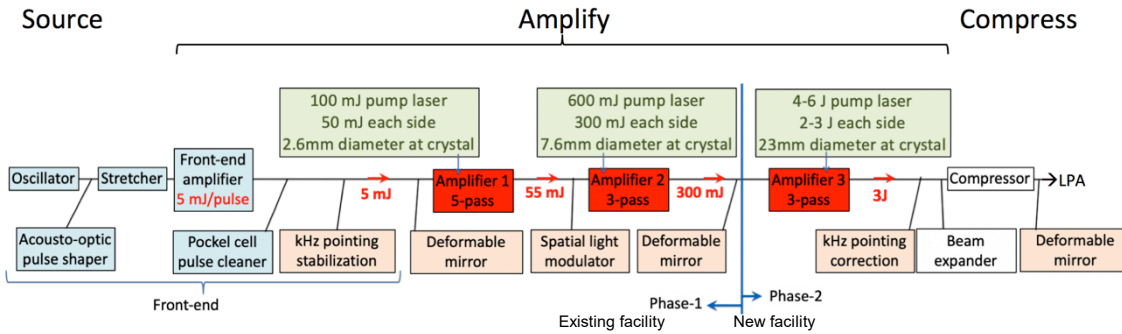

Design detailed: Layout and > 200 line BOM

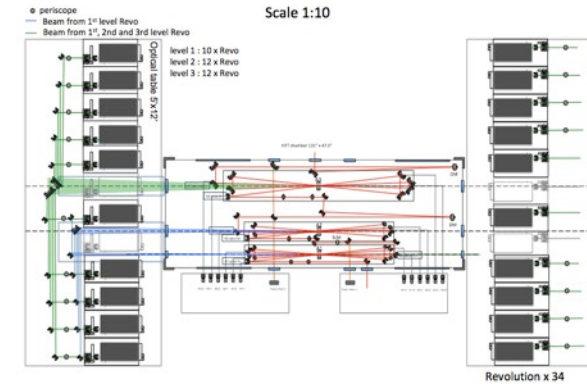

Laser energy pump
Diode pump lasers (Commercial)



Also: Colorado State, TRUMPF, MIT-LL

Heat extraction
Cryo cooling

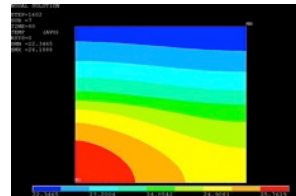

Compression
Dielectric Gratings

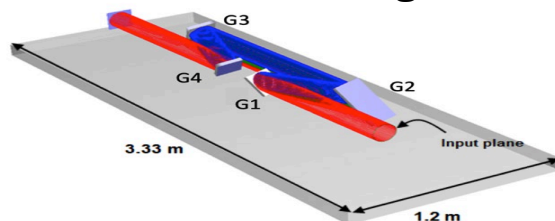

Based on established 100 TW system

Direct path to GeV kHz system for LPA studies.

LBNL - LLE – LLNL
MIT-LL and Colorado State discussions

Other technologies needed for high efficiency > few %
and repetition rates beyond kHz class

Towards Application Luminosity Needs: Developing High Repetition Rate Lasers (Joint with BACI)

Fiber lasers enable: beyond kHz with high efficiency

- Critical for collider roadmap
- Combine ~100 fibers × Stack 100 pulses temporally for Joule energy

LBLN – U. M. – LLNL projects developing architecture

- Stewardship: Scalable diffractive combining – Combined 81 low energy beams
Coherent pulse stacking – Stacked 81 high energy pulses
- ECRP (Qiang Du): Controls for efficient combining & stacking
- New ECRP (Tong Zhou): Spectral combining for 30fs pulses & LPA demo

Near term path to hundreds of mJ, 10's of fs systems

- Future 10 Joule class, 10's of kHz collider drivers

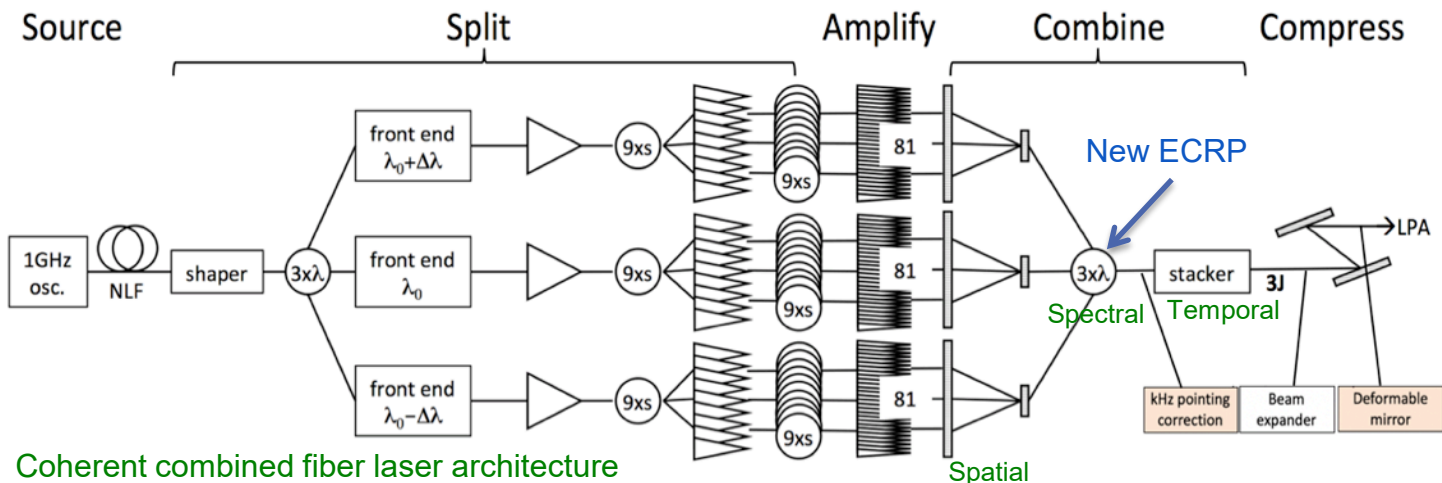
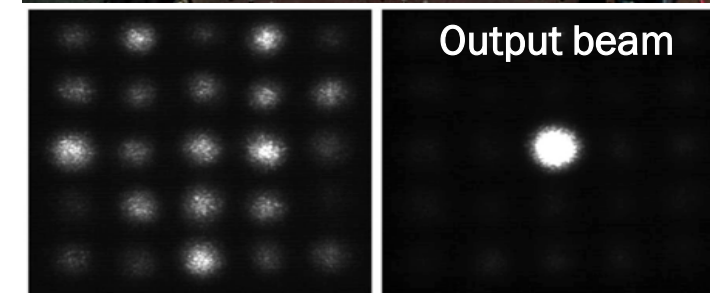
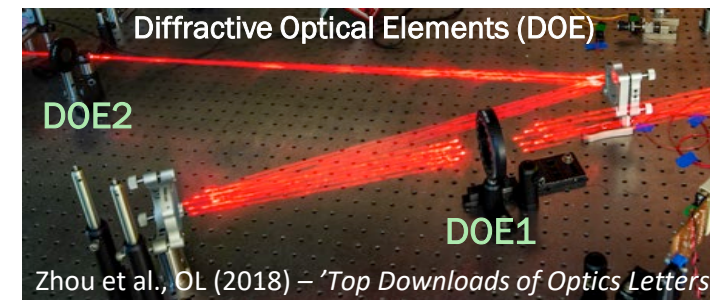

Distributed Spectral Filtering preserves amplified bandwidth for short pulses

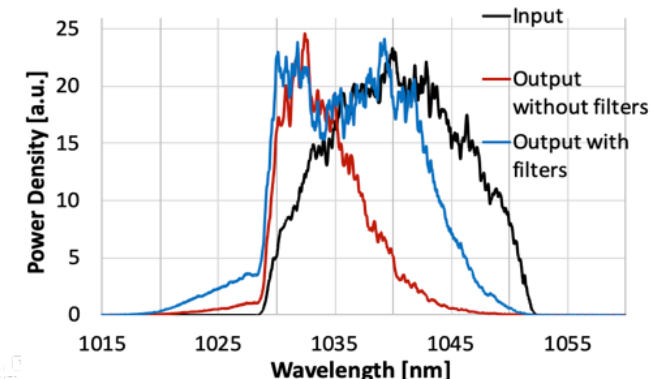

Laser Technology Path Established for Future High Efficiency

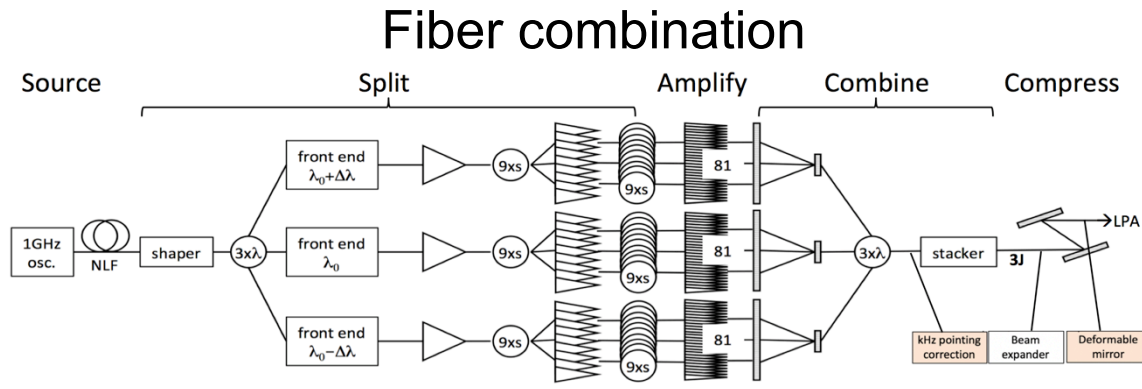

Phase 1 would have a subset of channels.

LBL-U.M.-LLNL

LLNL lead – Leily Kiani

R&D under accelerator stewardship program

- Technical roadmaps in progress for both technologies

Path in next 5 years for fiber and Tm:YLF

- 100's of mJ, 100 fs class systems feasible
- Build full Joule-class compressor & support systems to provide for future expansion
- Laser development platform
- Future path for fiber and Tm:YLF
 - Highly efficient systems
 - 10's of kHz at Joules of energy and 30-60fs

Tm:YLF

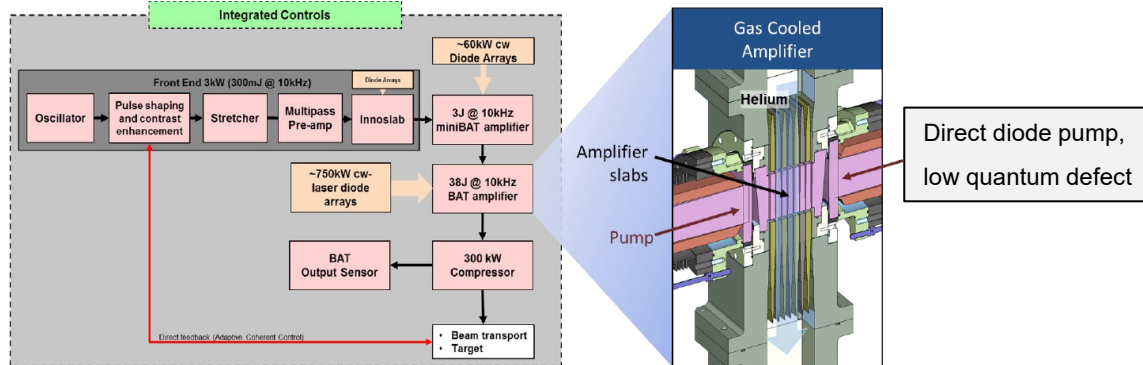

LLNL with LBNL discussion

Courtesy: Tom Spinka, LLNL

kBELLA Initiative Under Development for kHz, Joule-class LPA

High priority in community and funding agency plans for precision LPA

- Ti:sapphire is ready to execute at GeV class in next few years
- Fiber & Tm:YLF offer path to future high efficiency, with lower energy in near term
- Facility supporting multiple lasers for immediate experiments and long term development
- Key step on collider roadmap and enables photon sources and precision HEDS

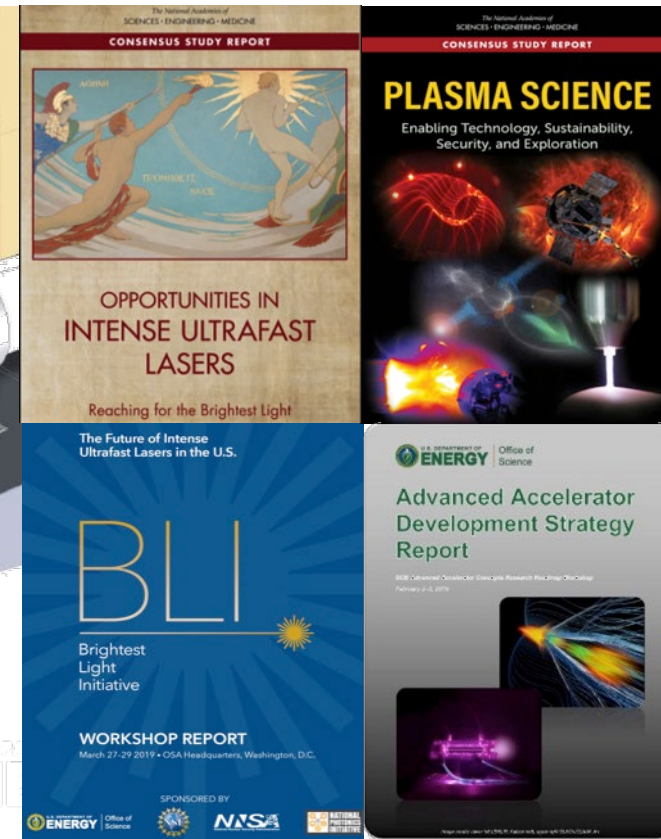
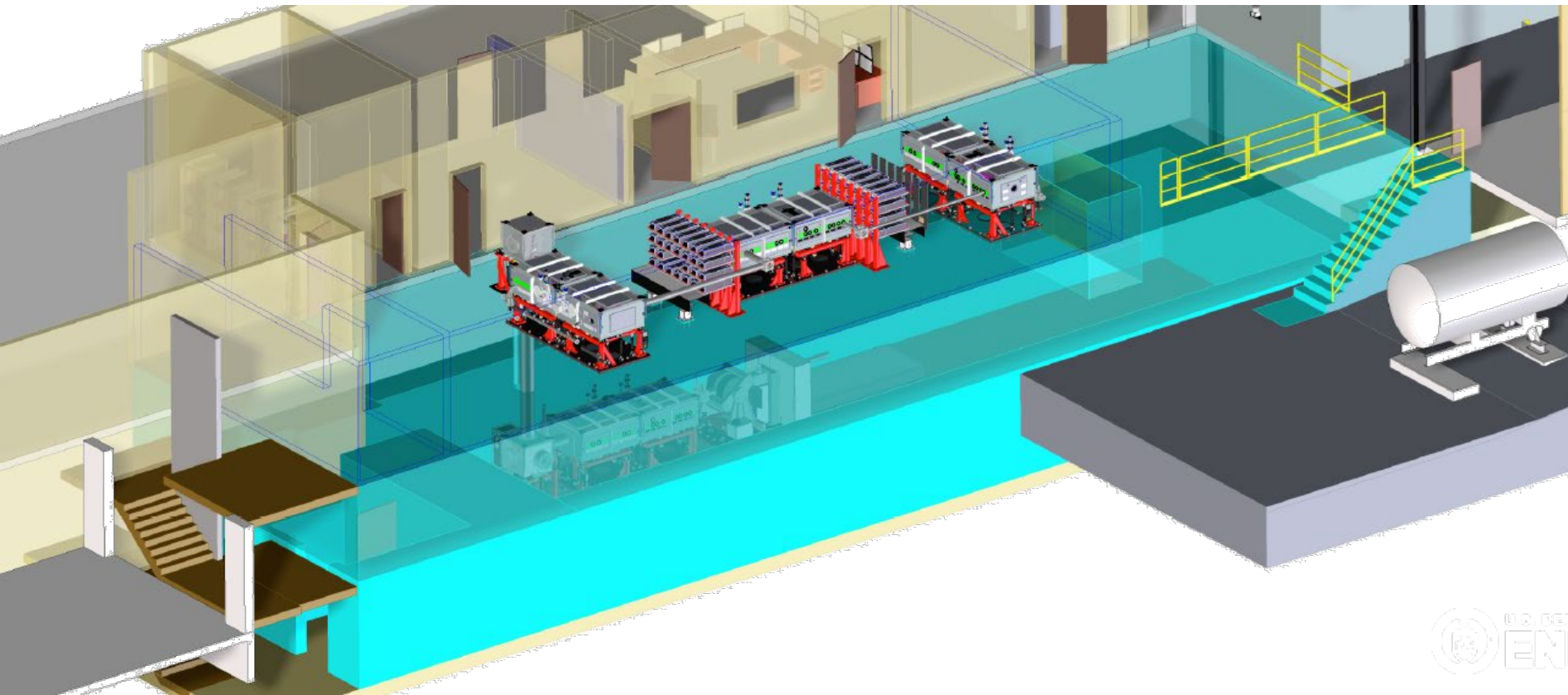

Summary

- Mono-energetic MeV Photon Sources based on LPA offer a revolution in X-ray applications: 10x-100x reduced dose with increased resolution and new signatures
- Existing project is demonstrating baseline per-shot parameters for a compact mono-energetic source at 5Hz with a path to transportable systems
 - Path to high performance in energy spread, flux, deceleration
- kHz rates accessible using new ultrafast Joule-class lasers
- Opportunities for signature & physics development and testing
 - Large-object & high resolution radiography & material ID
 - Photofission signatures (polarization, isomers...) & data
 - Fast timing and gamma LIDAR
 - NRF and pulsed neutron spectroscopy
 - Nuclear physics and astrophysics

backup material

1.5 MeV Photon Energy and Photon Number Analysis

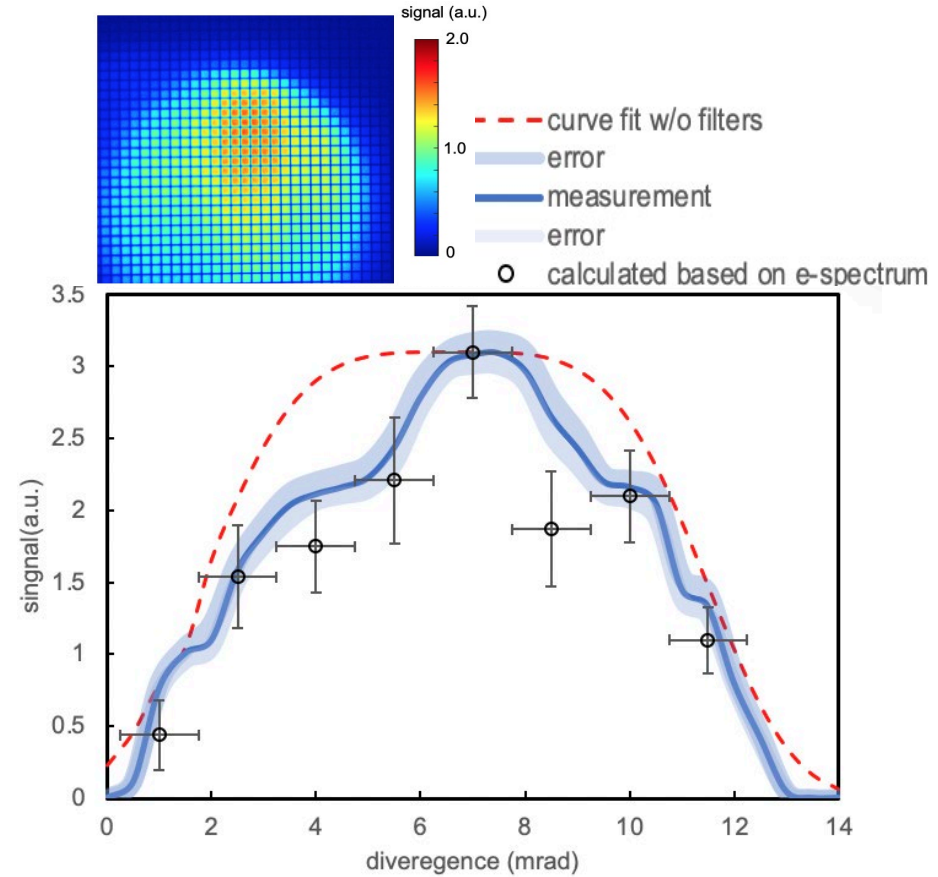
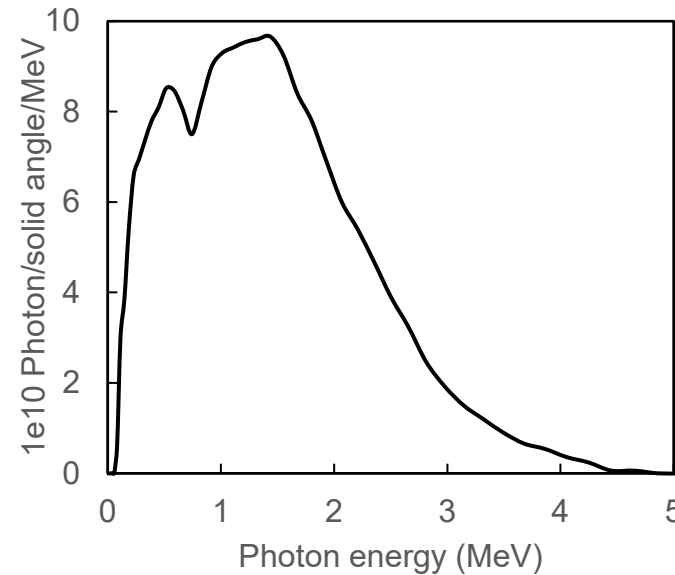
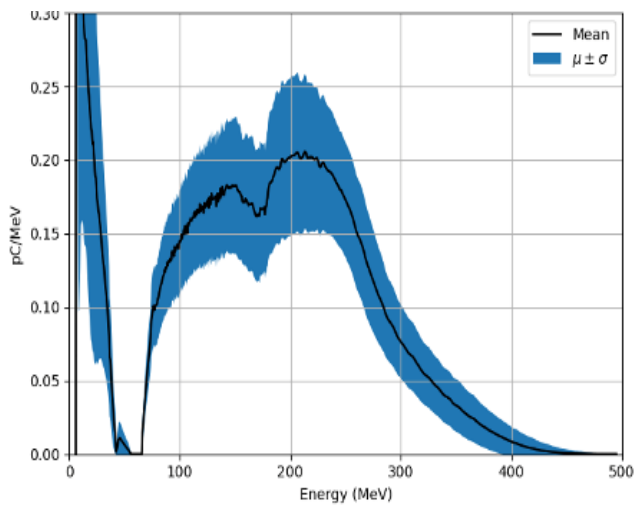
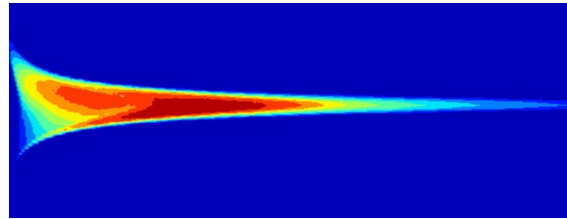
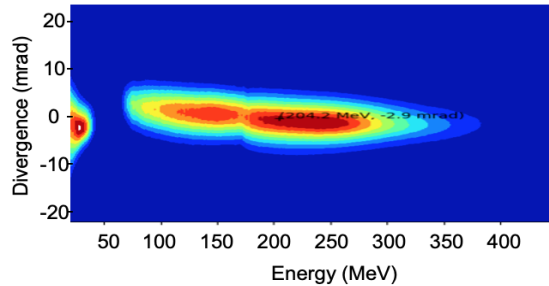

- Electron spectrum centered at 250MeV
- Simulated photon spectrum center at 1.5MeV based on electron spectrum
- Good agreement between measured (blue line) and simulated (black dots) transmittances
- Measured photon number $N_d = S_{tot} / (\alpha \varepsilon \theta / 4\pi QE) = 1.5 \times 10^7$

kHz-mJ laser-plasma accelerator provides a high rep-rate platform to study precision feedback control, critical for HEP collider modules and applications

- kHz-mJ driver laser accomplished; Two types of LPA targets being tested
- Demonstrated laser beam pointing stabilization with 10x reduced fluctuation, needed for future HEP LPA injectors & staging
- kHz laser mode correction under investigation, important for precision mode control in future HEP LPAs

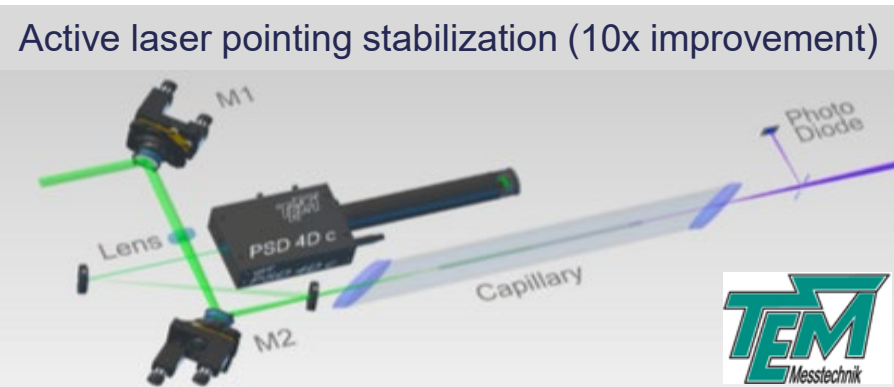

Funded by: LBNL LDRD; Varian Medical Systems

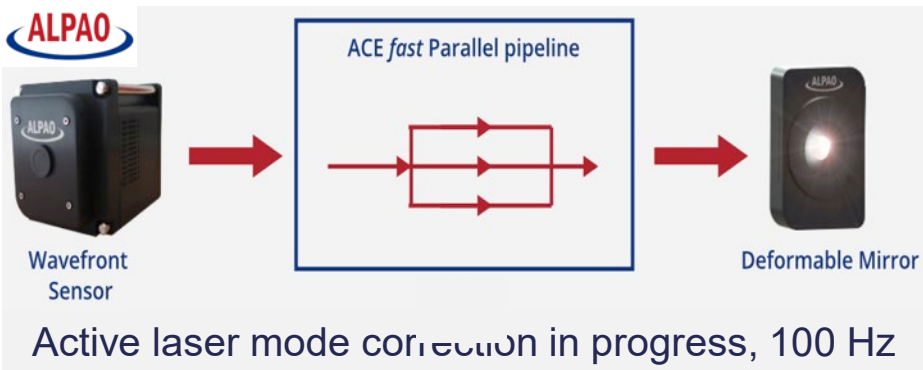
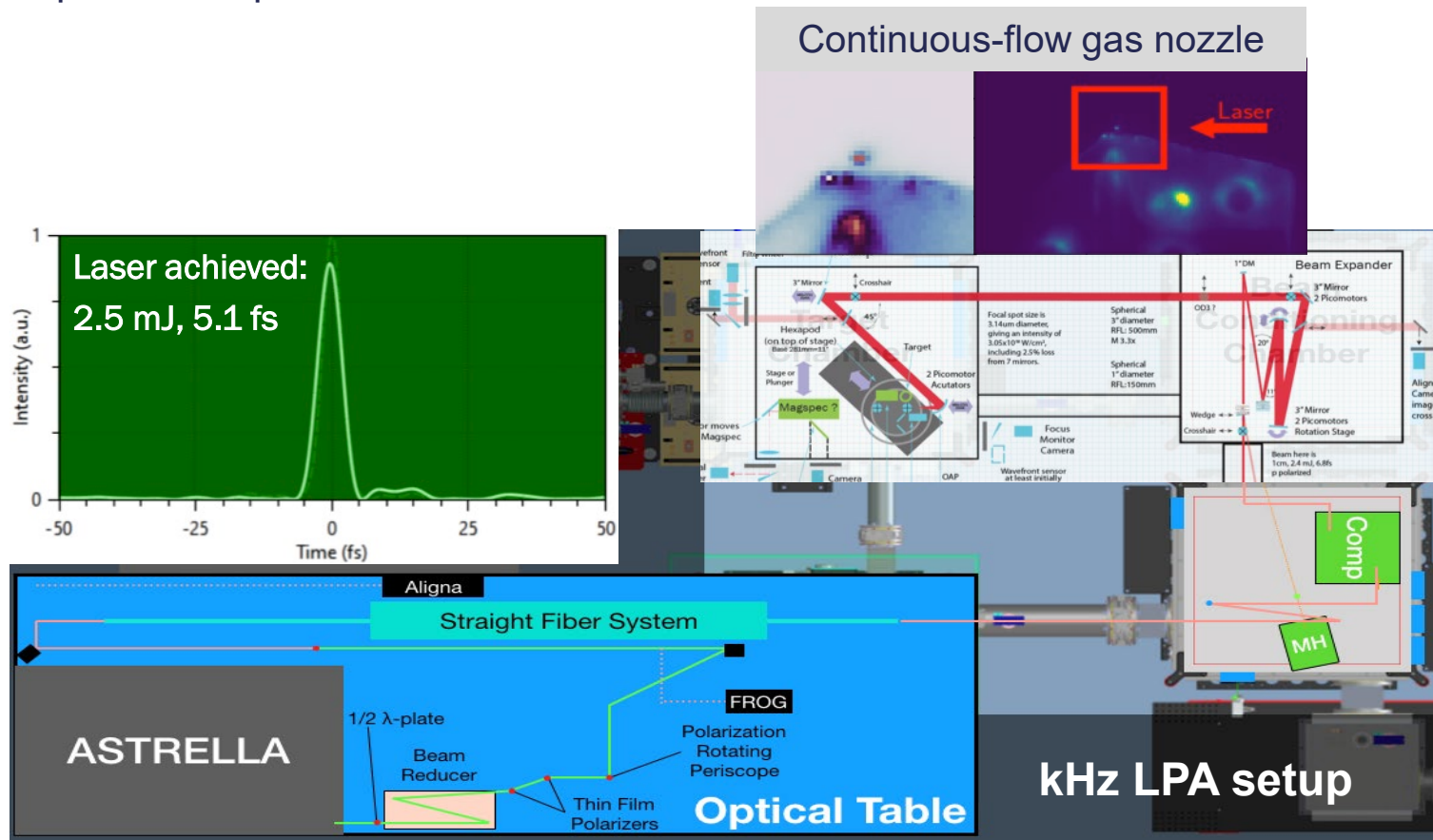

Other controllable parameters to improve LPA (at kHz & beyond) precision: carrier-envelope phase, laser energy fluctuation, etc.

Ultraintense Lasers Enable Science and Applications: From the Frontiers of Fundamental Physics to Industry, Security and Medicine

HEP Future Particle Colliders
NP Nuclear Science

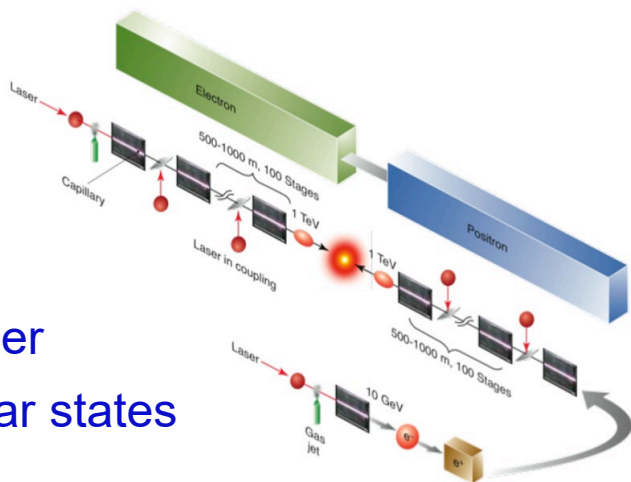

Extend energy frontier
Access exotic nuclear states

FES High Energy Density Science
NIH/NCI Oncology

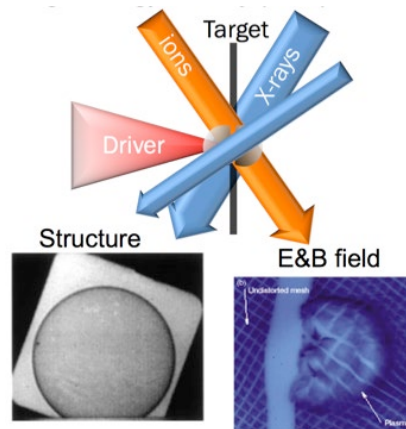

Precision probes/pumps
New therapy sources

BES and Industry Coherent X-rays

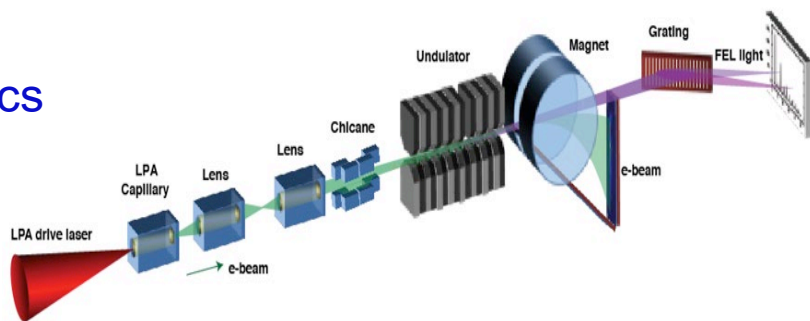

Compact FELs
Molecular dynamics
Microelectronics

DoD, NNSA, Industry and Medical
Sensing & X-rays

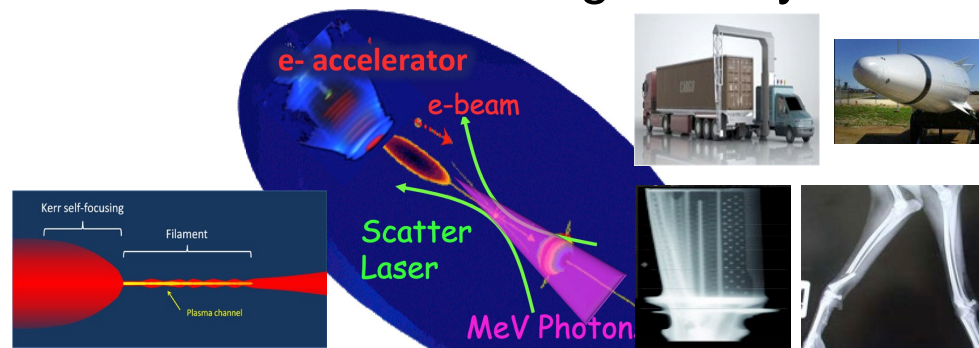

Precision
Mono-Energy
High res.
Remote sensing

The reach of fundamental science and the capabilities of applications
are limited by device size

Integrated experiment to demonstrate, laser-plasma driven, compact photon system concept

- Laser operates reliably, delivering required synchronized and independent pulses
 - LPA drive: Short (40fs) pulse, >2 J on target
 - Scattering laser: 40fs-1ps, >0.5 J on target
 - Initial : split from LPA drive (10-25mJ)
 - Current: independent scatter laser
 - Recovered pump laser failure (cost: 8 mo.)
- Experiments operating using laser & facility
 - Photon targets shielded from accelerator
 - Large room for meter-scale photon targets
- Over-sized Laser, experiment chamber:
 - Flexible configuration/source development
 - Extensible (beyond current project) to demonstrate reduced source size & increased flux via pulse shaping
 - Same laser can produce neutron source

Laser and target area operational

