

# Calibration and Performance of the ICARUS Detector at Fermilab

Matteo Vicenzi ([mvicenzi@bnl.gov](mailto:mvicenzi@bnl.gov))  
on behalf of the ICARUS Collaboration

CPAD 2025 at Penn  
October 7<sup>th</sup>, 2025

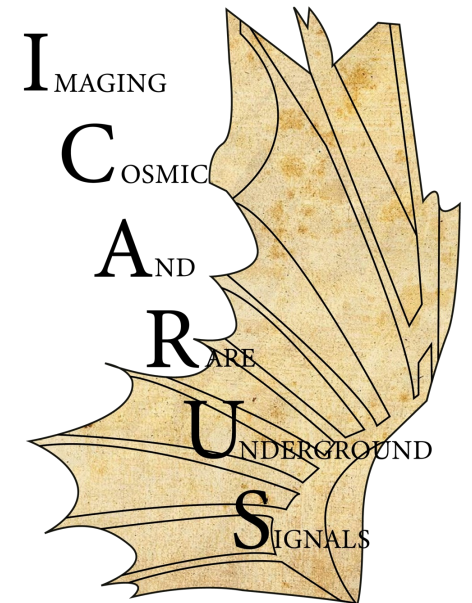

# Short Baseline Neutrino @ Fermilab



# The ICARUS detector

- ICARUS is a **large liquid argon detector** (~476 active tons), divided into 2 identical modules.
  - Each hosting 2 TPCs that share a central cathode plane ( $E=500$  V/cm).
- 360 Hamamatsu R5912-MOD 8” pTB-coated **PMTs** mounted behind the anode wires (90 per TPC).
- Enclosed in a  $\sim 4\pi$  **Cosmic Ray Tagger** (CRT) system + 3 m concrete overburden (10 m.w.e.).

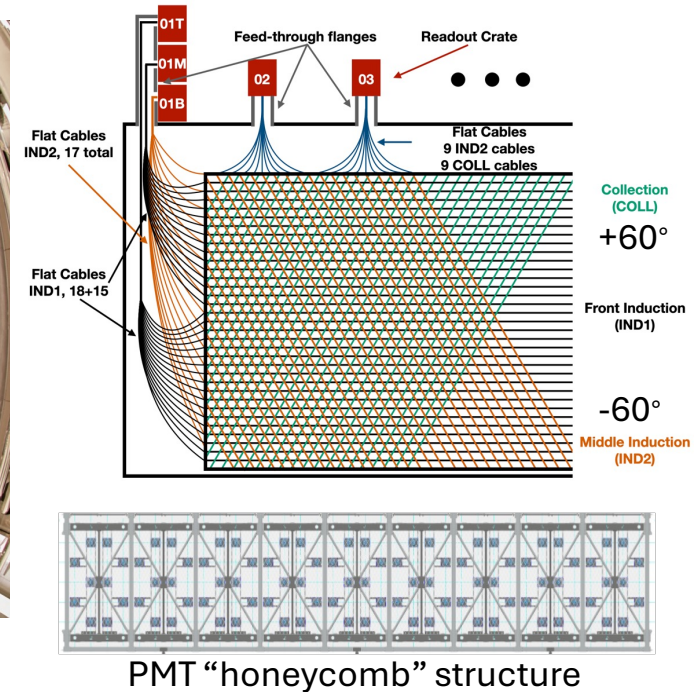
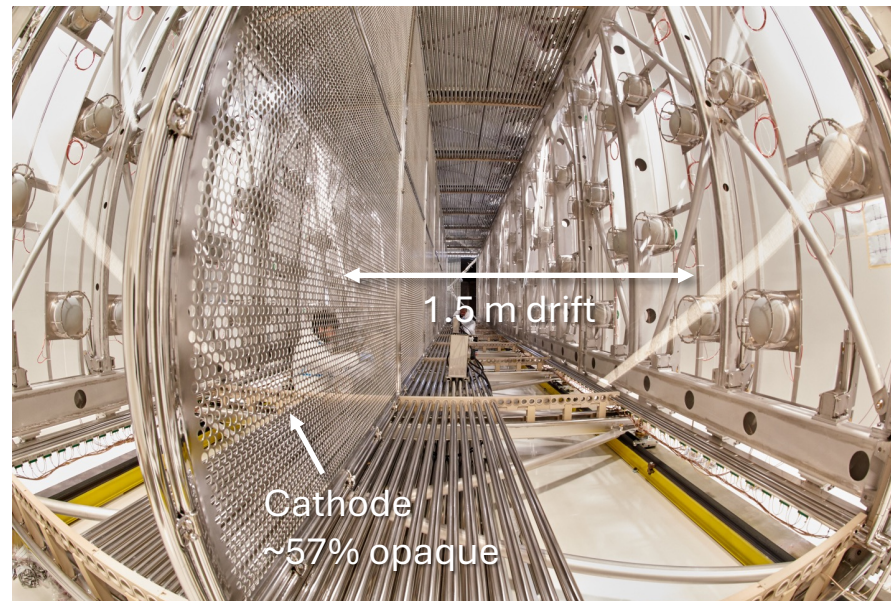
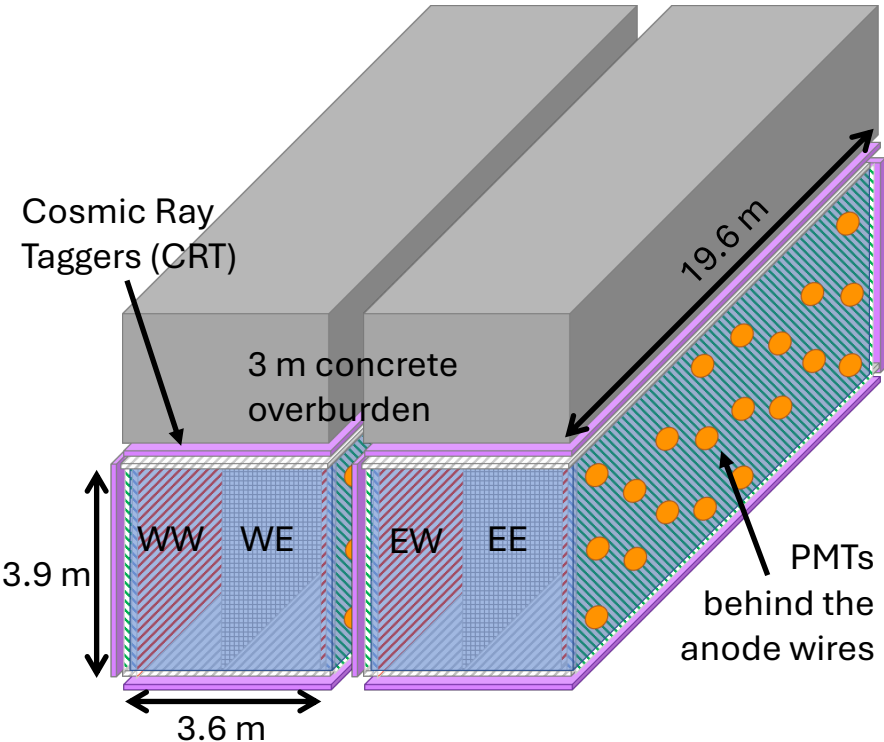

# ICARUS operations



2018

#IcarusTrip to Fermilab

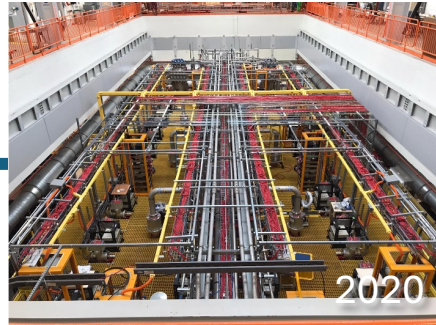

2020

Start of cold operations, commissioning

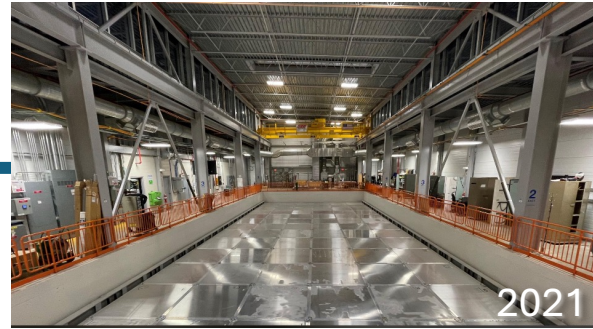

2021

CRT cover installed, end of commissioning



2022

Overburden installed, start of physics data

- Celebrating **5 years** of continuous cold operations!

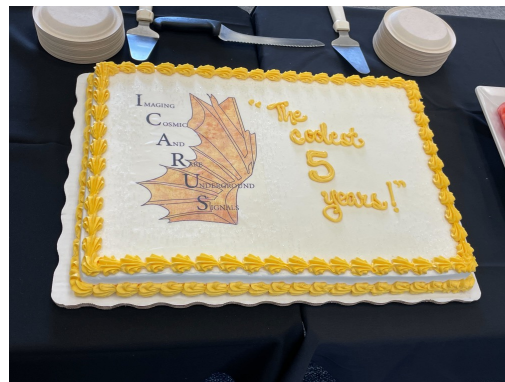

[Eur.Phys.J.C 83 \(2023\) 6, 467](#)

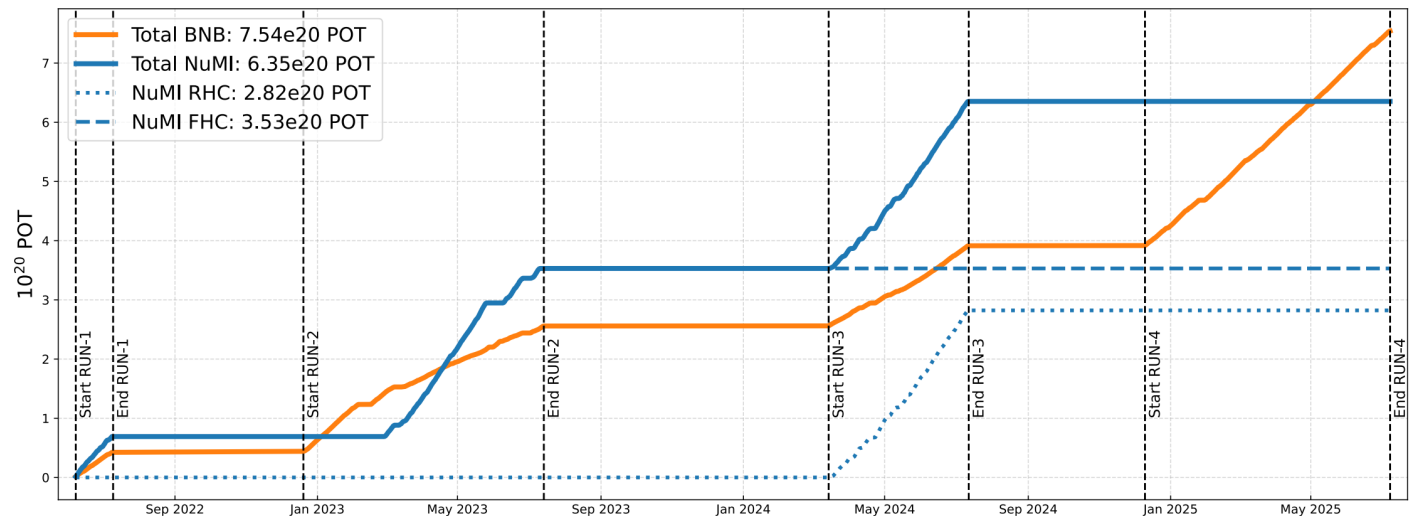

# Recent ICARUS results!

BSM with NuMI beam, eg. search for scalar decays into di-muon states

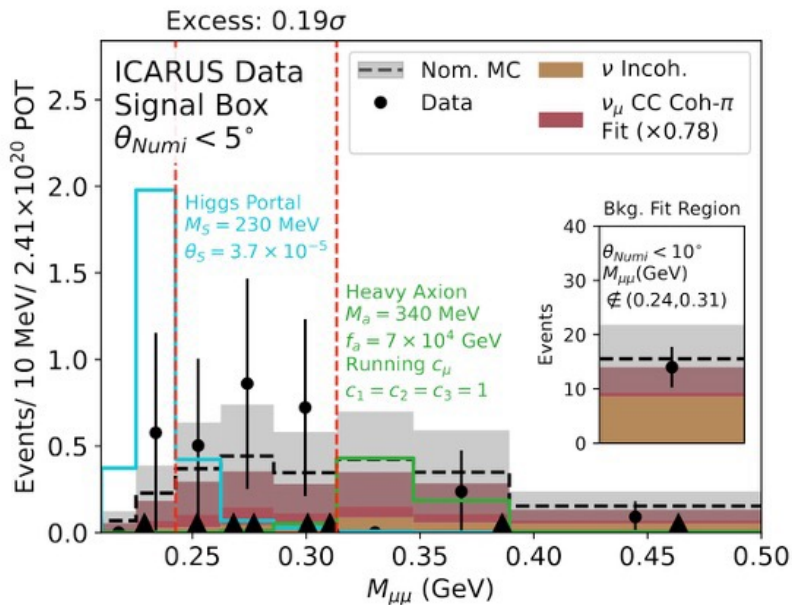

Paper out!

[Phys.Rev.Lett. 134 \(2025\) 15, 151801](#)

Cross-sections with NuMI beam, e.g.  $\nu_\mu \text{CC} 0\pi N p$

Paper in preparation!

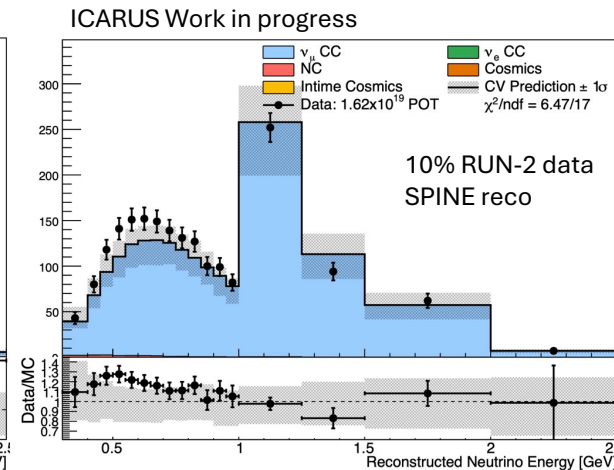
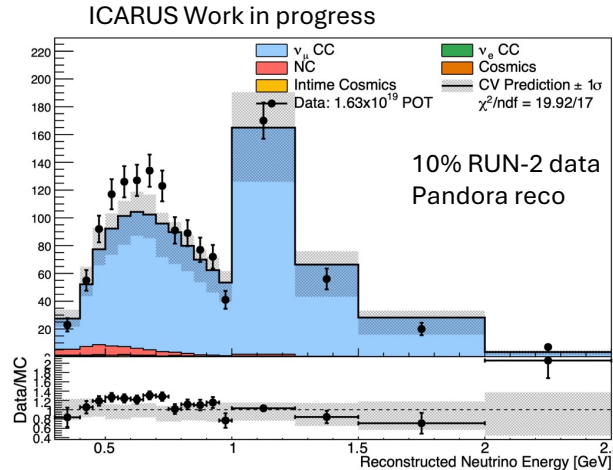
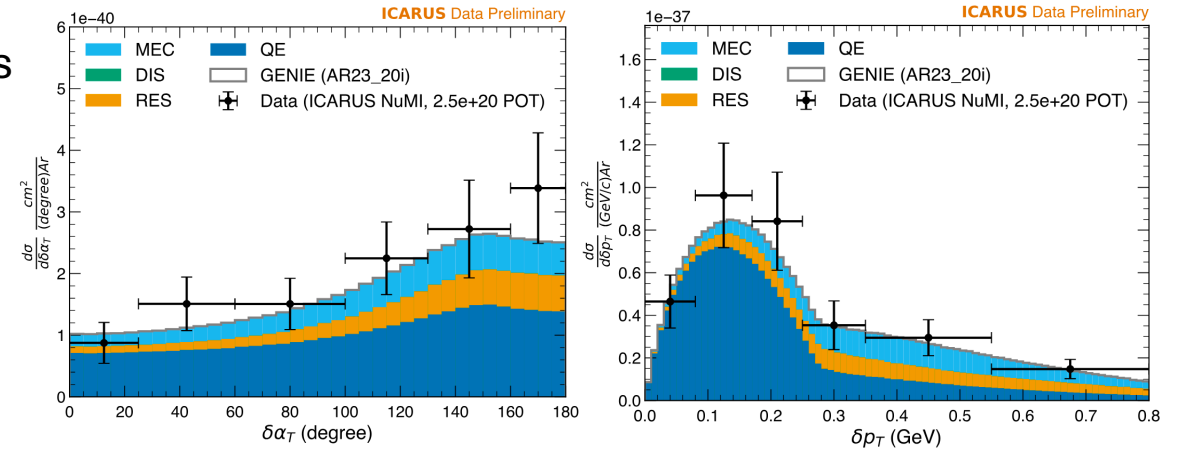

ICARUS-only  $\nu_\mu$  disapp. analysis

100% data unblinded, out soon!

SBN-wide results will follow – stay tuned!

# Cosmics for calibration

- On the surface, cosmics are a nuisance... but also “**standard candles**”!
  1. Known  $dE/dx$  profile is used to obtain the calorimetric **energy scale**.

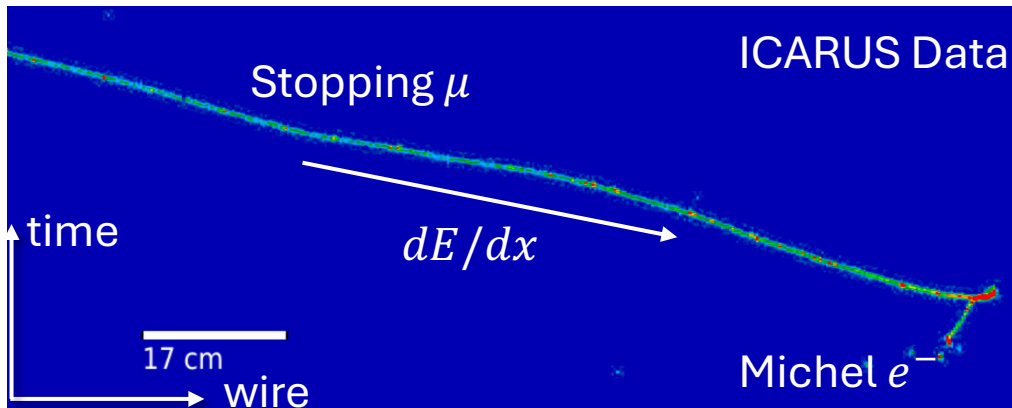

$$Q [\text{ADC}] \rightarrow Q [e^-] \rightarrow E [\text{MeV}]$$

Charge response  
calibration

Energy  
calibration

“through-going”  
muons = MIPs

stopping muons = Bragg  
peak (non-linearity)

# Cosmics for calibration

- On the surface, cosmics are a nuisance... but also “**standard candles!**”
  - Known  $dE/dx$  profile is used to obtain the calorimetric **energy scale**.

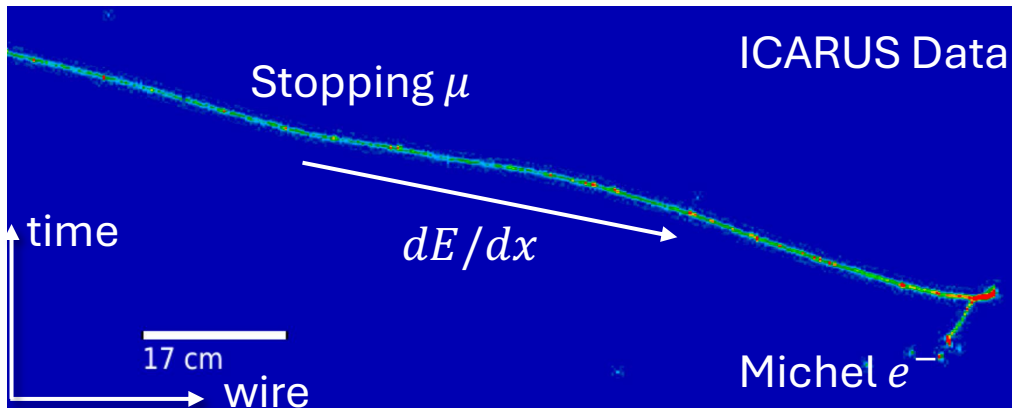

$$Q [\text{ADC}] \rightarrow Q [e^-] \rightarrow E [\text{MeV}]$$

Charge response  
calibration

Energy  
calibration

“through-going”  
muons = MIPs

stopping muons = Bragg  
peak (non-linearity)

- Vertical muons provide a reference to equalize the scintillation light **time response + calorimetric scale**

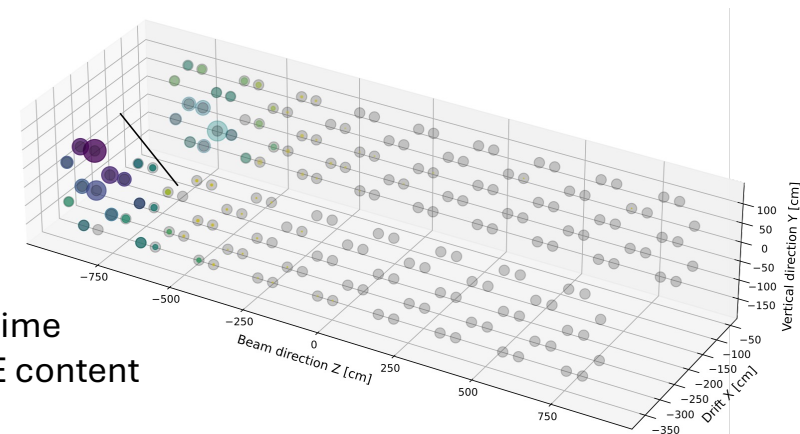

# Charge/energy calibration

From collected charge to energy deposition

# Charge response non-uniformity

Several effects can smear the measured charge response ( $dQ/dx$ ):

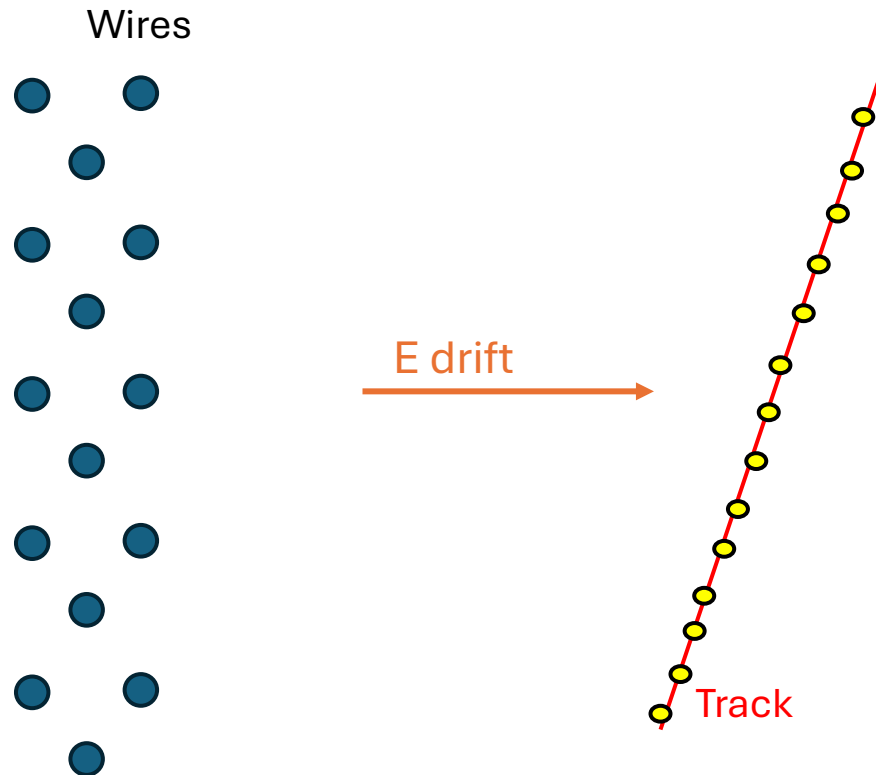

# Charge response non-uniformity

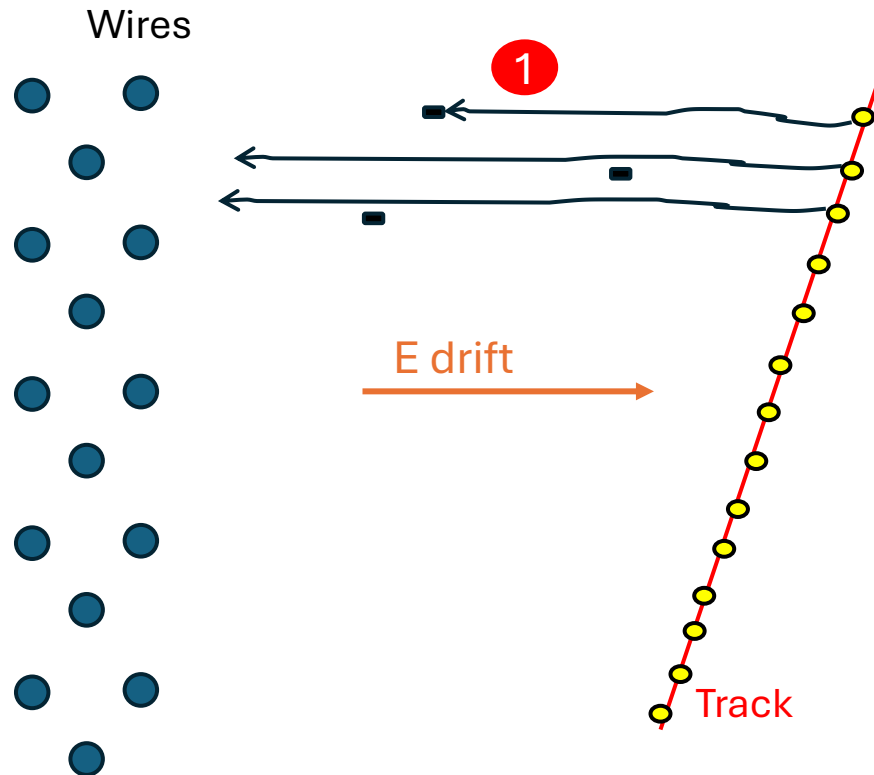

Several effects can smear the measured charge response ( $dQ/dx$ ):

1. **Argon impurities:** exponential attenuation (electron lifetime)

# Charge response non-uniformity

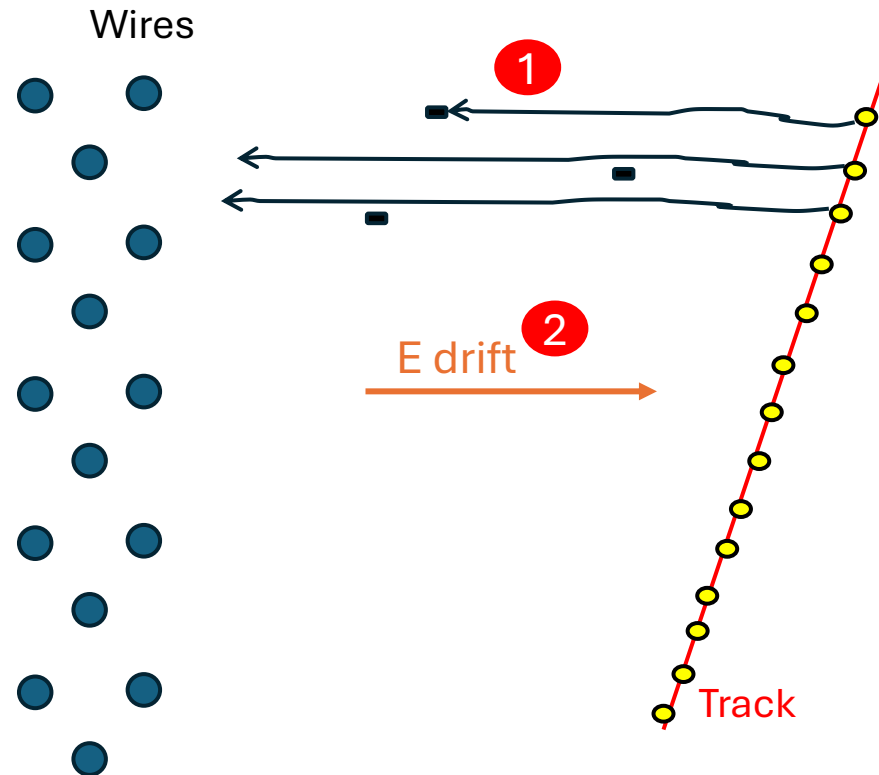

Several effects can smear the measured charge response ( $dQ/dx$ ):

1. **Argon impurities:** exponential attenuation (electron lifetime)
2. **Drift field distortions** (space charge, cathode non-planarity..)

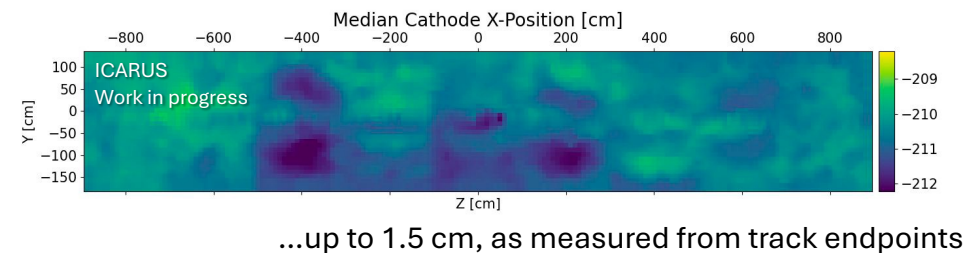

# Charge response non-uniformity

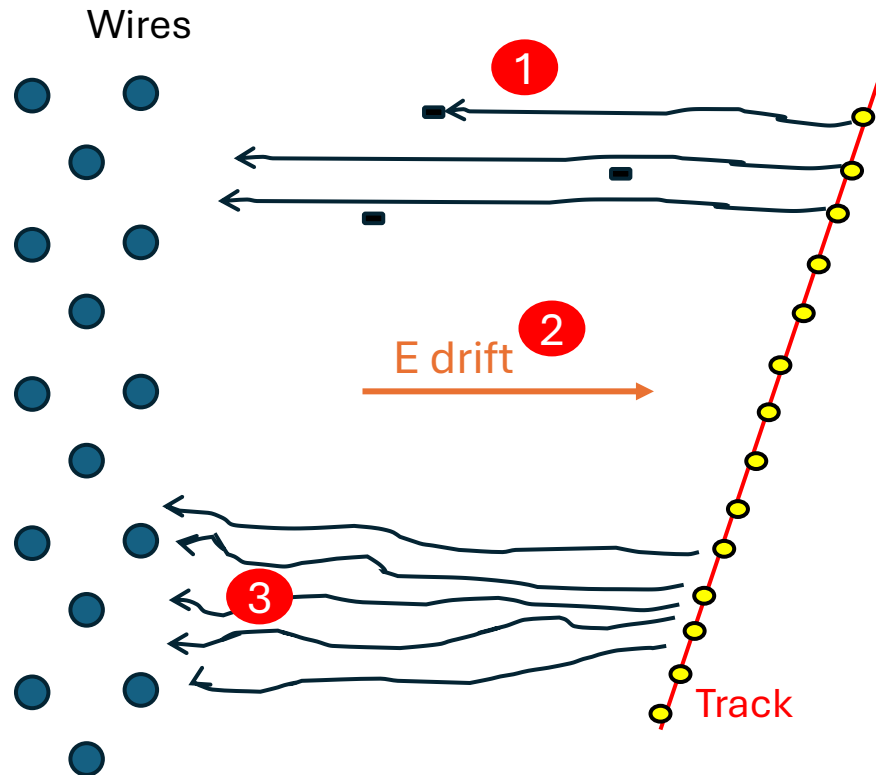

Several effects can smear the measured charge response ( $dQ/dx$ ):

1. **Argon impurities:** exponential attenuation (electron lifetime)
2. **Drift field distortions** (space charge, cathode non-planarity..)
3. **Diffusion:** smears the observed charge deposition ( $dQ/dx$  MPV appears larger!)

# Charge response non-uniformity

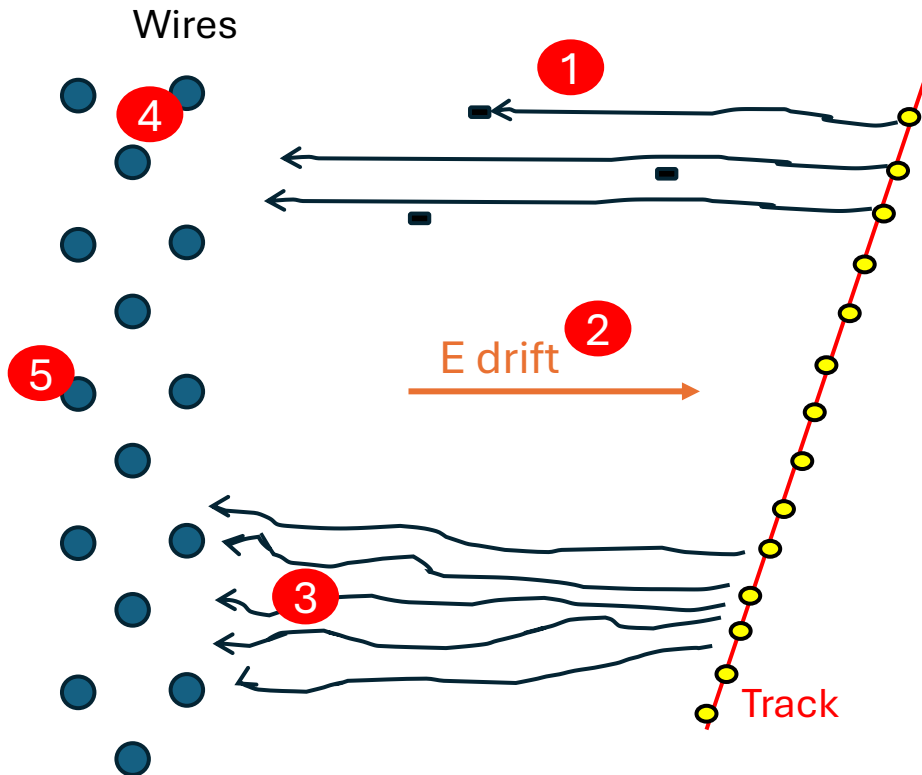

Several effects can smear the measured charge response ( $dQ/dx$ ):

1. **Argon impurities:** exponential attenuation (electron lifetime)
2. **Drift field distortions** (space charge, cathode non-planarity..)
3. **Diffusion:** smears the observed charge deposition ( $dQ/dx$  MPV appears larger!)
4. **Induction plane intransparency:** non-uniform charge absorption
5. **Channel gain variations**

# Drift correction

- **Cathode-to-anode** crossing muons:  $dQ/dx$  MPV is constant, but looks attenuated (impurities, ...) as a function of drift coordinate.
  - Make it flat to remove the effect!
- Diffusion also distorts it  $\rightarrow$  average it out by grouping wires together!

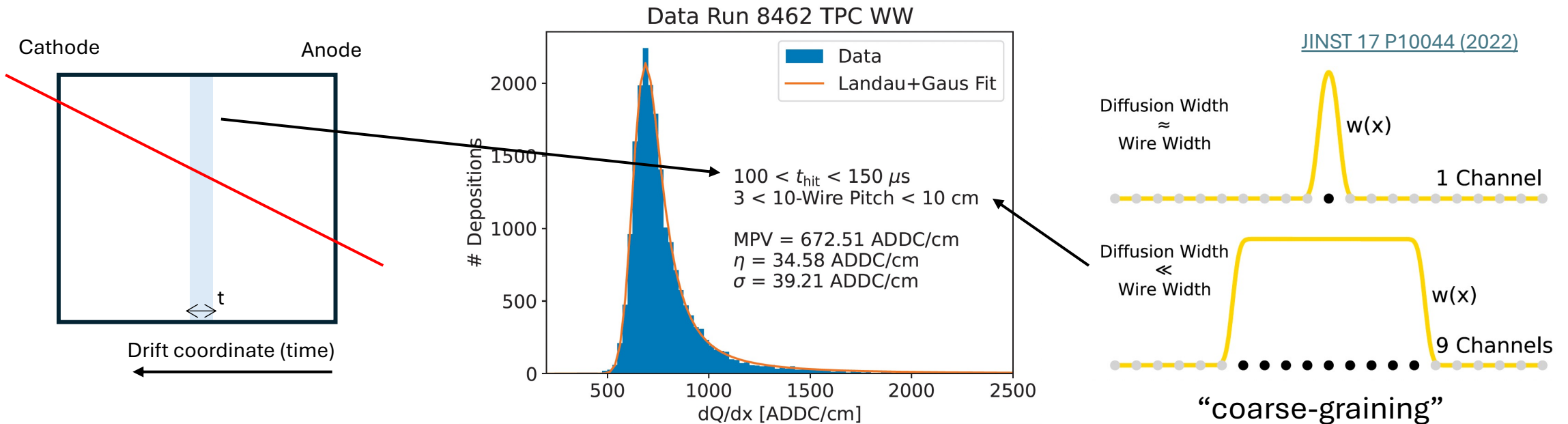

# Drift correction

- **Cathode-to-anode** crossing muons:  $dQ/dx$  MPV is constant, but looks attenuated (impurities, ...) as a function of drift coordinate.
  - Make it flat to remove the effect!
- Diffusion also distorts it → average it out by grouping wires together!

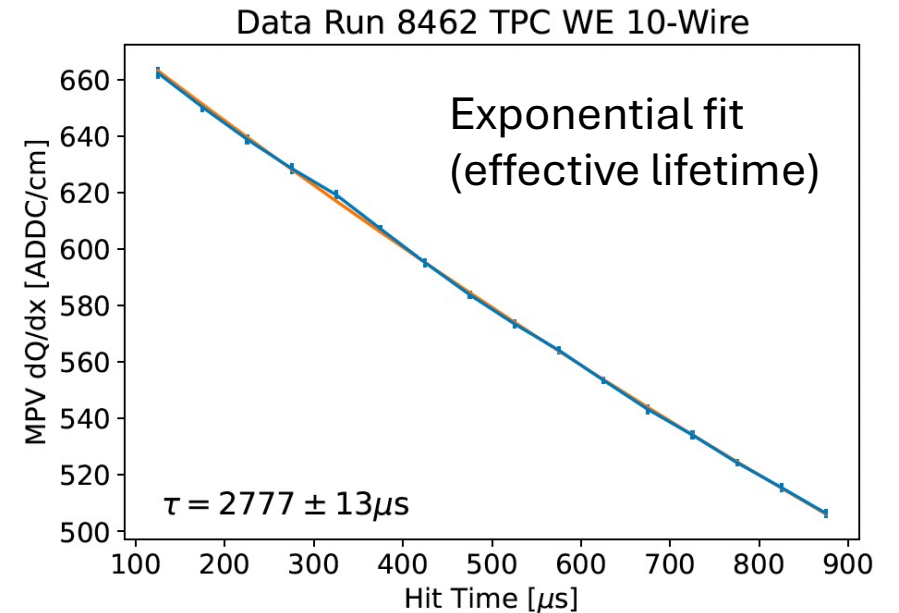
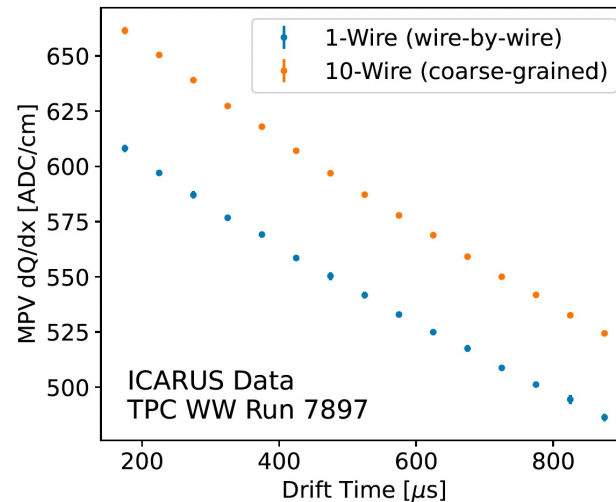
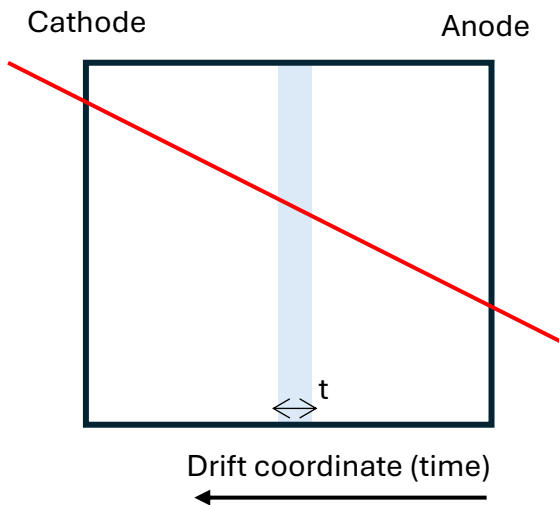

# Wire plane (ZY) correction

- Induction planes have been found to **collect charge** in a non-uniform way.
- Binning “coarse-grained”  $dQ/dx$  in the plane coordinates ( $10 \times 10 \text{ cm}^2$ )  $\rightarrow$  fit MPV in each bin and extract **scale factor to equalize** the plane.

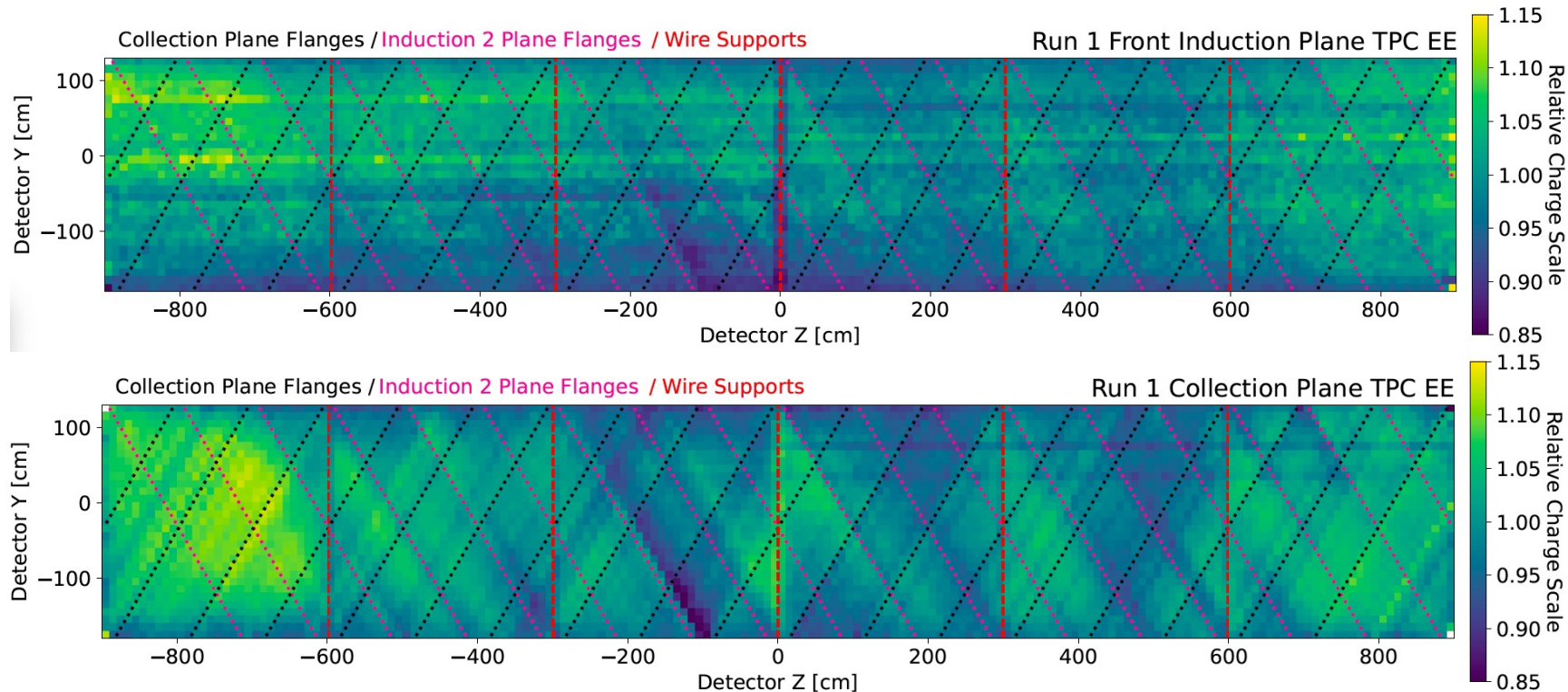

“intransparency maps”  
1 for each wire plane,  
3 for each TPC

Some features are correlated  
with the wire supports

# TPC equalization

- Once the drift and wire plane correction have been applied, charge response is uniform in each TPC.
- Last step is **equalizing the 4 TPCs** to the same scale.

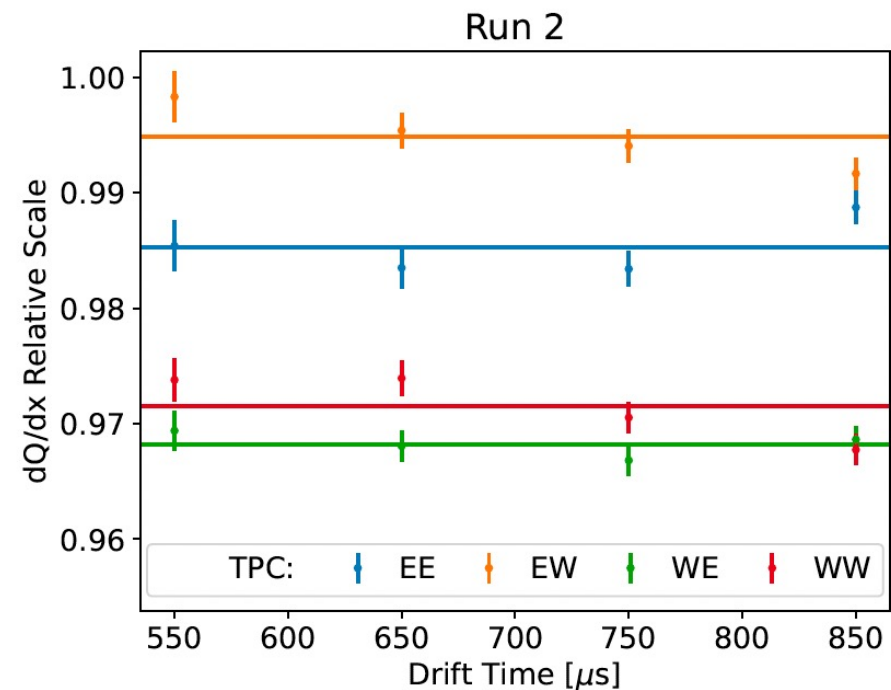
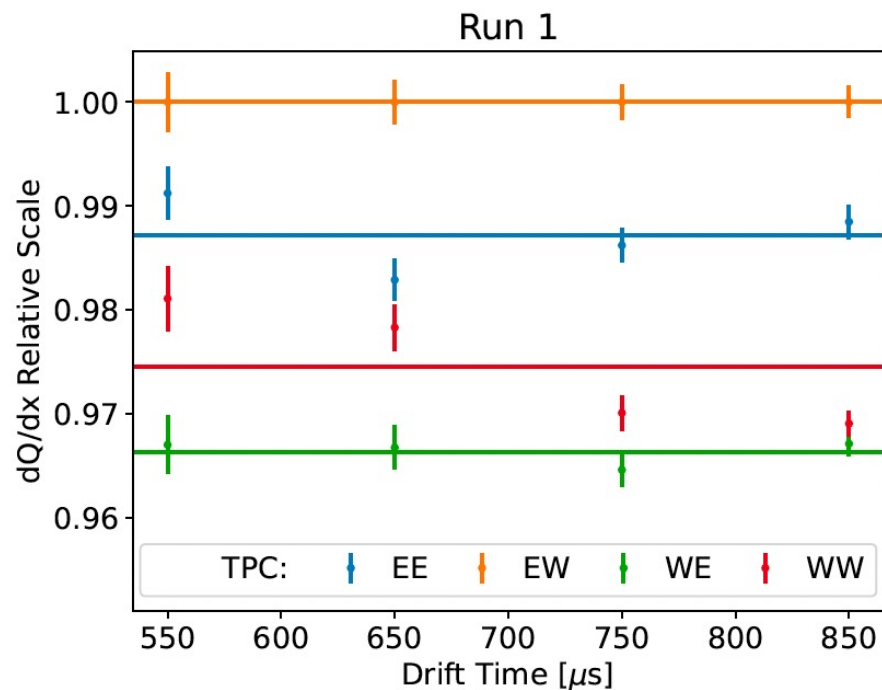

# Signal shape tuning

- “Intransparent” collection pulse in induction planes also affects/distorts the ionization **signal shape**.

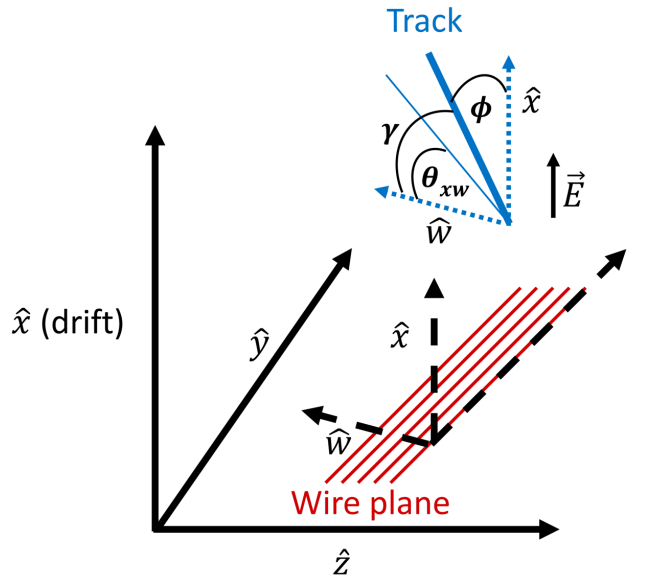

Shape strongly depends on track angle to wire plane  $\theta_{xw}$

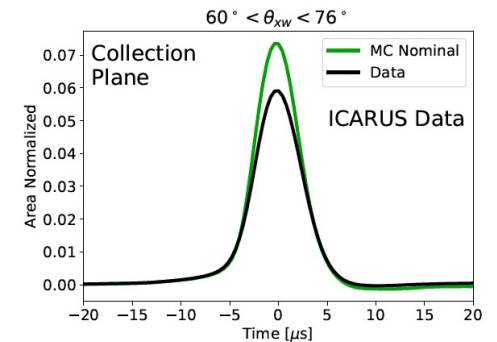
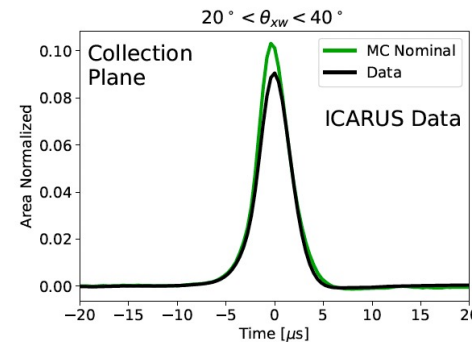
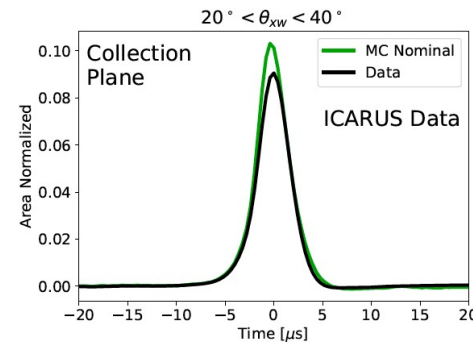
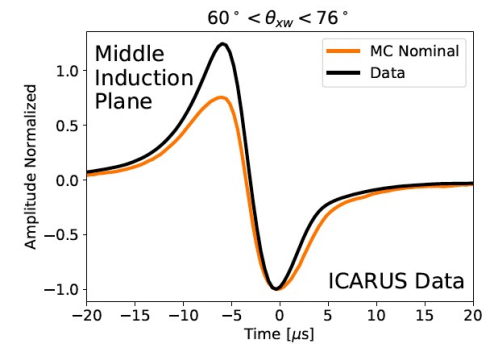
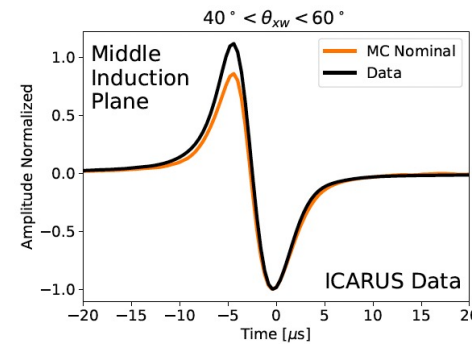
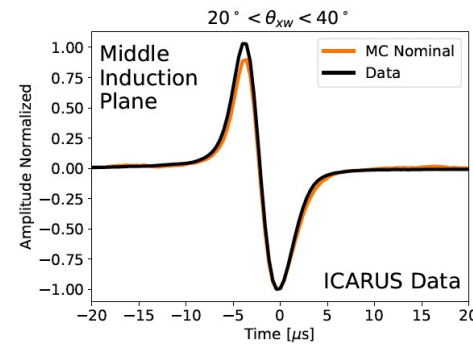

# Signal shape tuning

- “Intransparent” collection pulse in induction planes also affects/distorts the ionization **signal shape**.

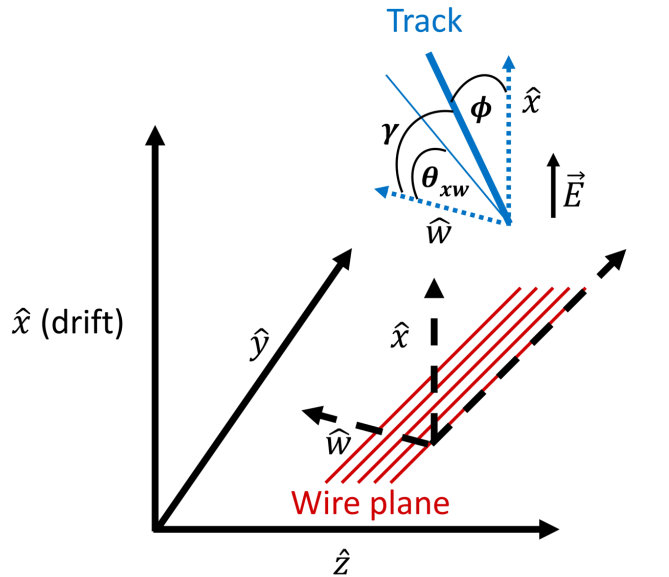

Shape strongly depends on track angle to wire plane  $\theta_{xw}$

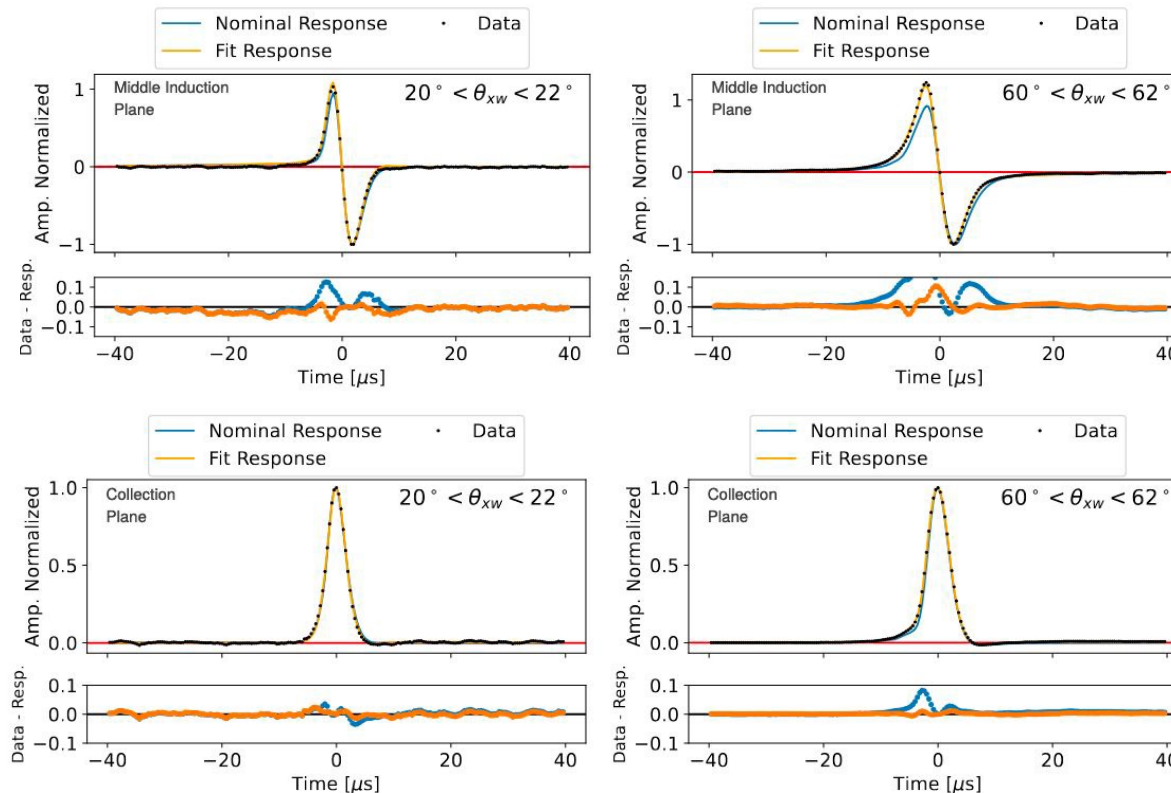

**Data-driven tuning, fitting the response simultaneously over all angle bins**

[JINST 20 \(2025\) 01, P01032](#)

# Charge response non-uniformity

Several effects can smear the measured charge response ( $dQ/dx$ ):

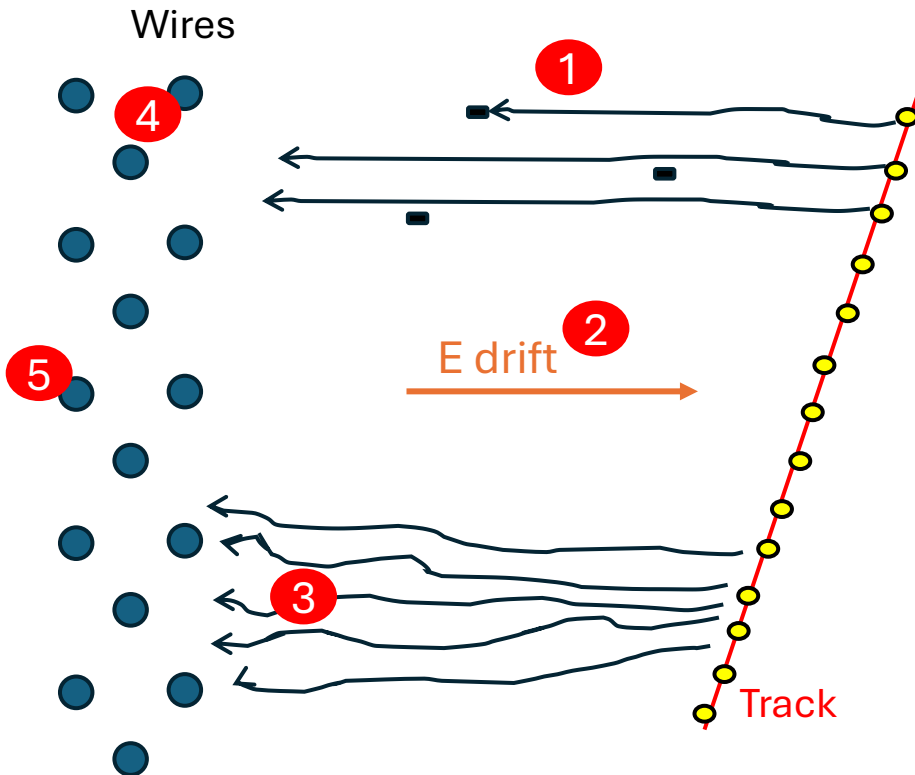

1. **Argon impurities:** exponential attenuation (electron lifetime)
2. **Drift field distortions** (space charge, cathode non-planarity..)
3. **Diffusion:** smears the observed charge deposition ( $dQ/dx$  MPV appears larger!)
4. **Induction plane intransparency:** non-uniform charge absorption
5. **Channel gain variations**

# Charge response non-uniformity

Several effects can smear the measured charge response ( $dQ/dx$ ):

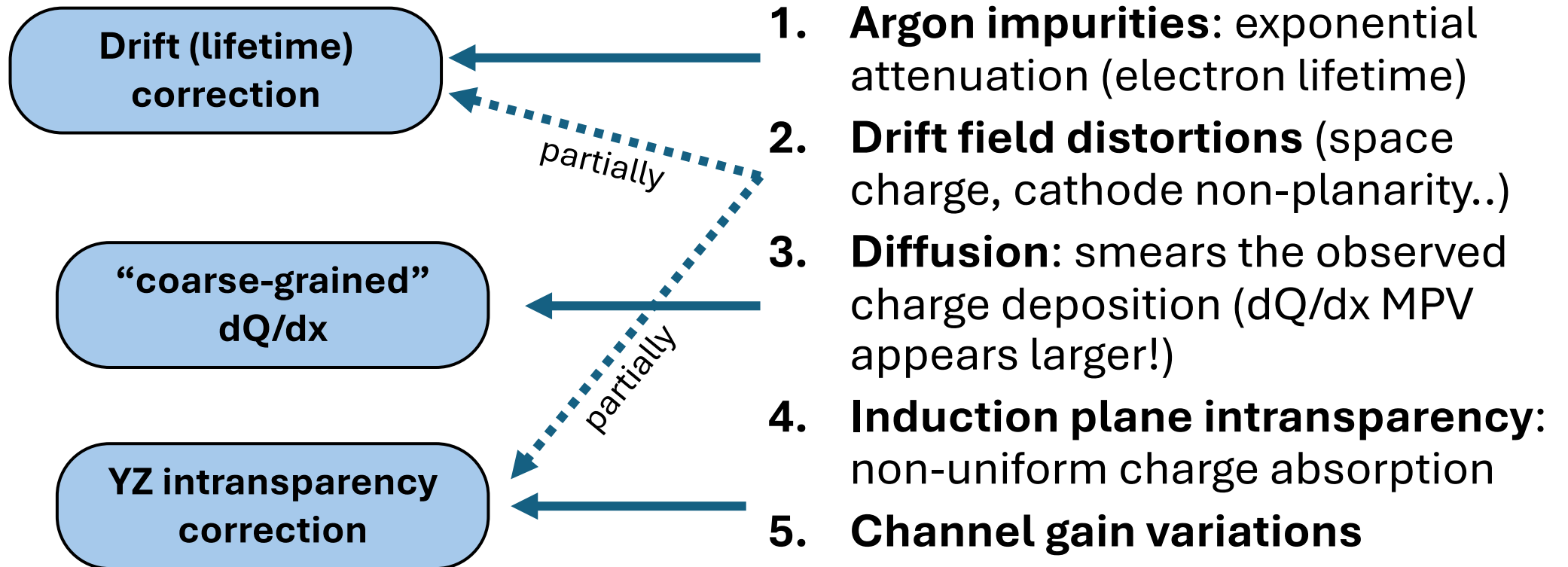

# Charge recombination

- Translating  $dQ/dx$  into  $dE/dx$  requires **recombination model**:

$$\frac{dQ}{dx} = \frac{1}{G} \frac{\log(\alpha + \beta \frac{dE}{dx})}{\beta W_{ion}}$$

**Ellipsoidal  
Modified  
Box (EMB)  
model**

ICARUS has found  $\beta = \beta(\phi)$   
Recombination parameter depends on **track angle!**

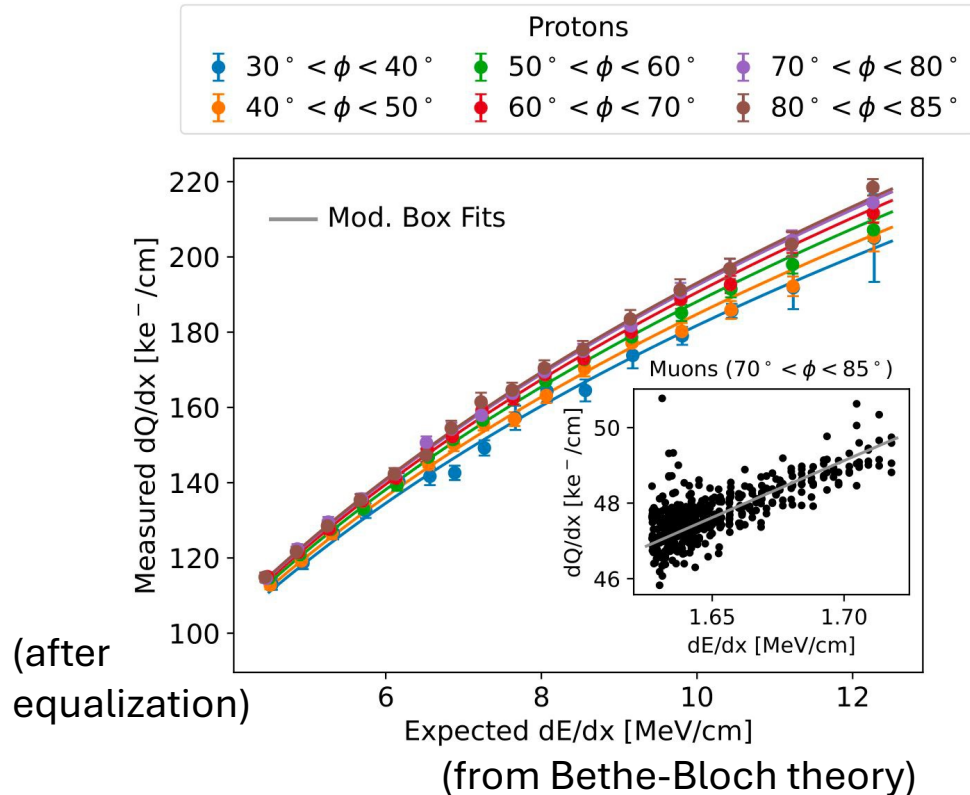

$\phi$ : angle of track to drift electric field

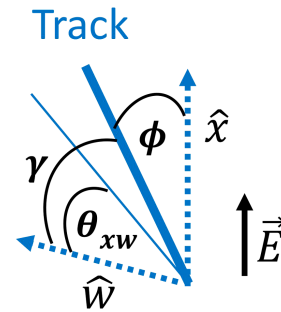

[JINST 20 \(2025\) 01, P01033](#)

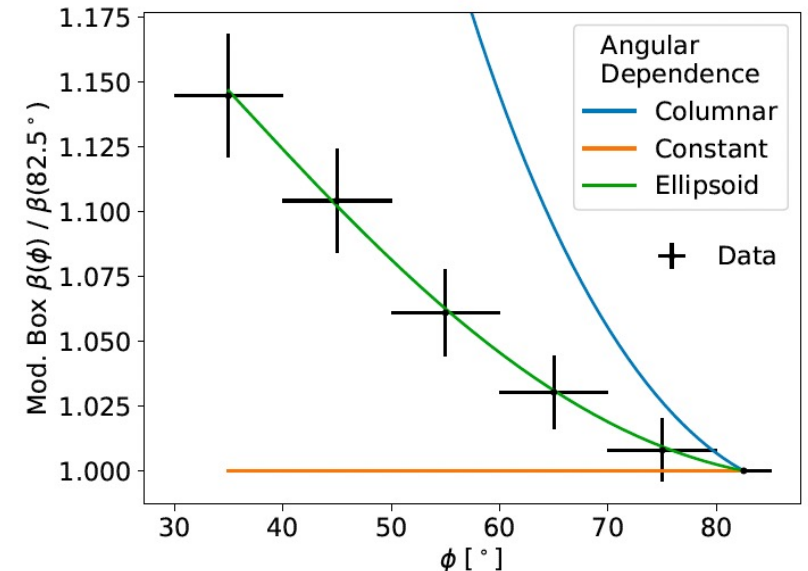

# Calorimetry performance

- Charge response equalization + EMB correction result in excellent calorimetric performance!

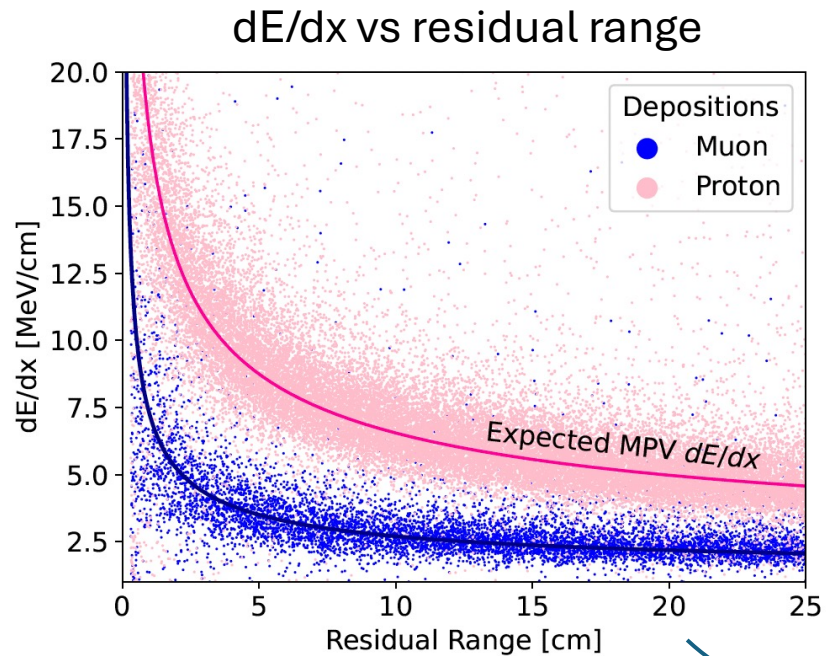

JINST 20 (2025) 01, P01033

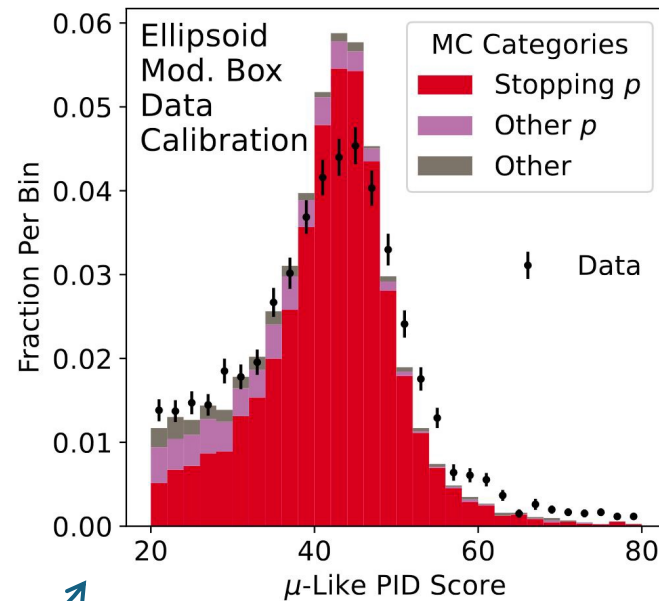

Input to PID!

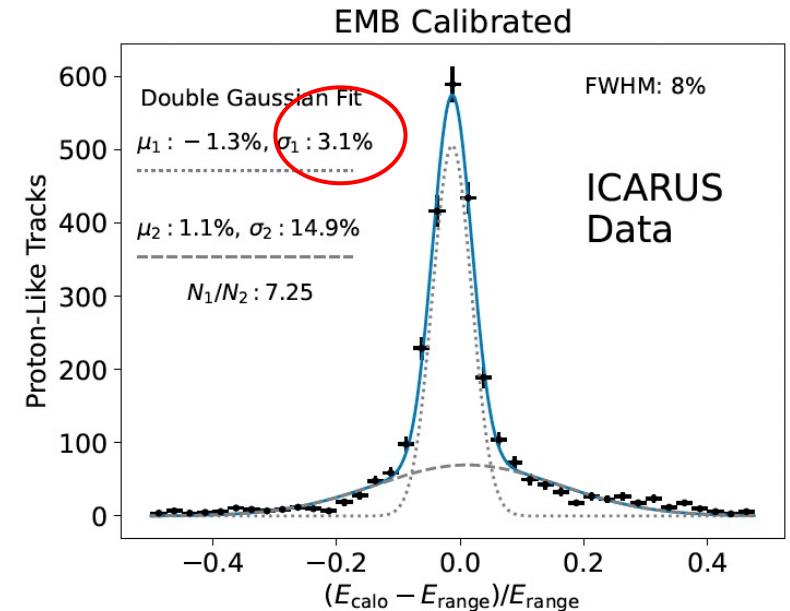

Comparing calorimetric vs range energy estimation for stopping protons

# Timing calibrations

Equalizing the timing response

# Laser calibration system

[Nucl.Instrum.Meth.A 1067 \(2024\) 169670](#)

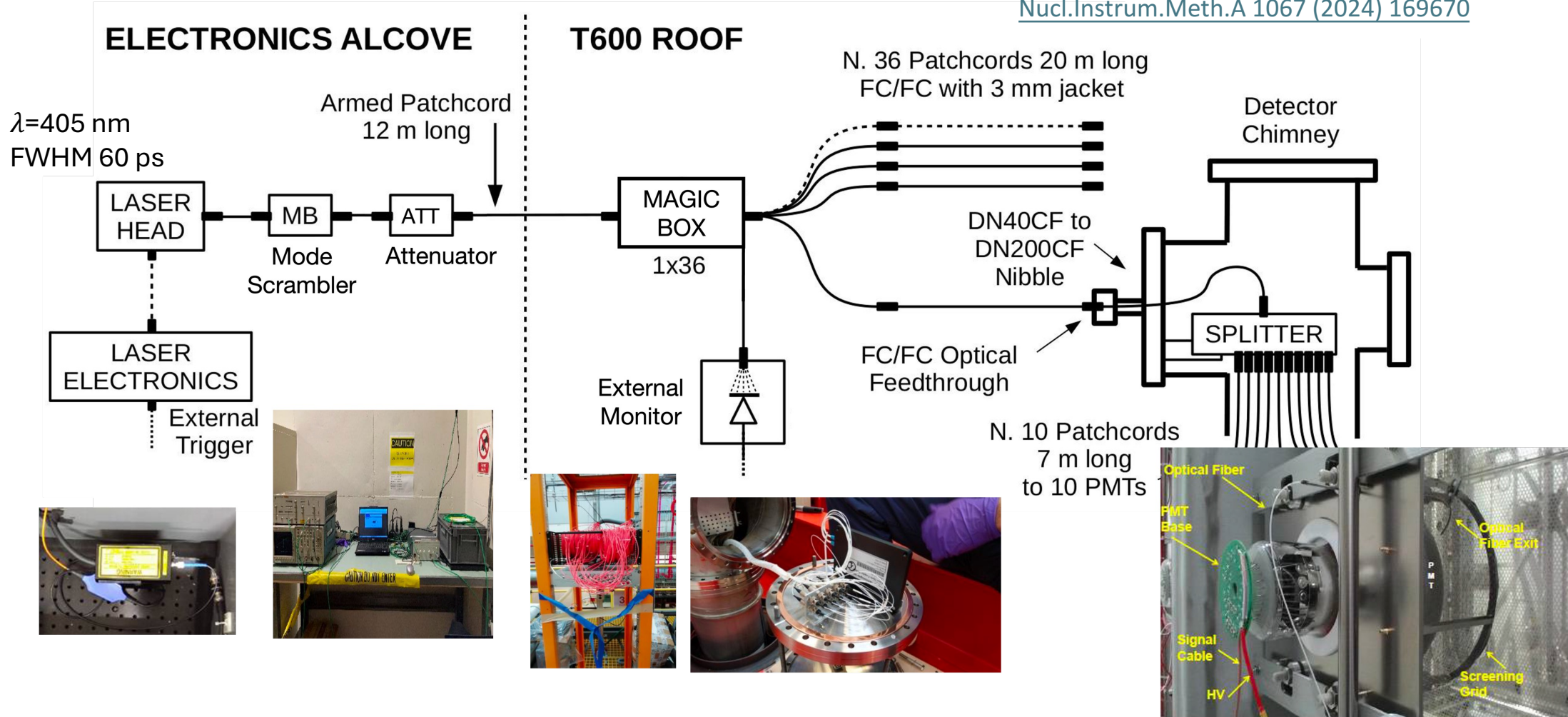

# Laser calibrations

- Measuring **signal delays** between light hitting the photocathode ( $t_{ph}$ ) and its signal being digitized ( $t_{dig}$ ) using instantaneous laser pulses.
- Delays are O(200ns): 38 m of the signal cables.
- Voltage differences produce ~10 ns spread (**electron transit time**).

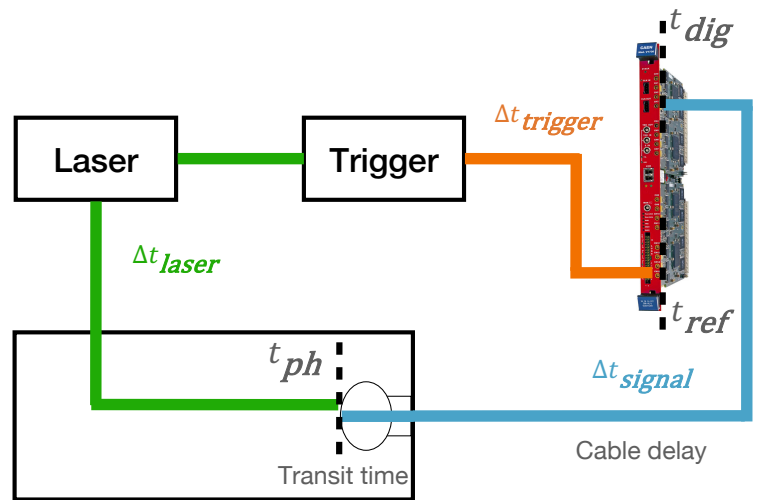

$$\Delta t_{signal} = \Delta t_{meas} + \Delta t_{trigger} - \Delta t_{laser}$$

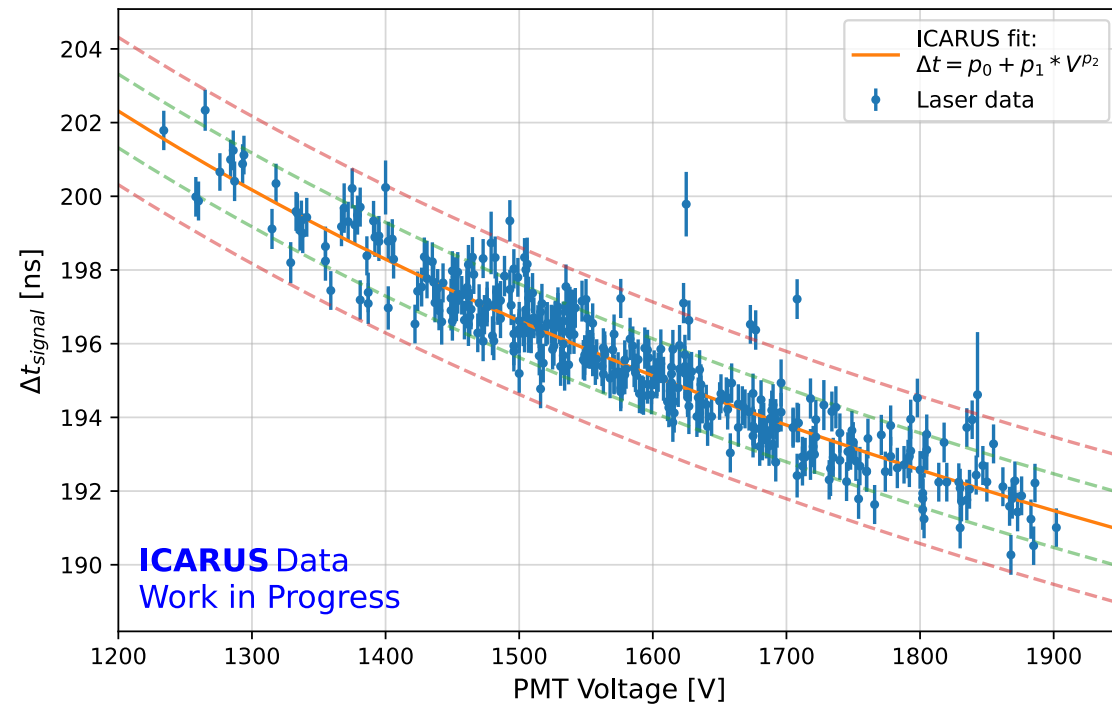

# Cosmics calibrations

- **Vertical cosmics:** linear relationship is expected between PMT y-coordinate and time.
- Deviations are due to z-position w.r.t the track or x-coordinate if track is closer to one wall.

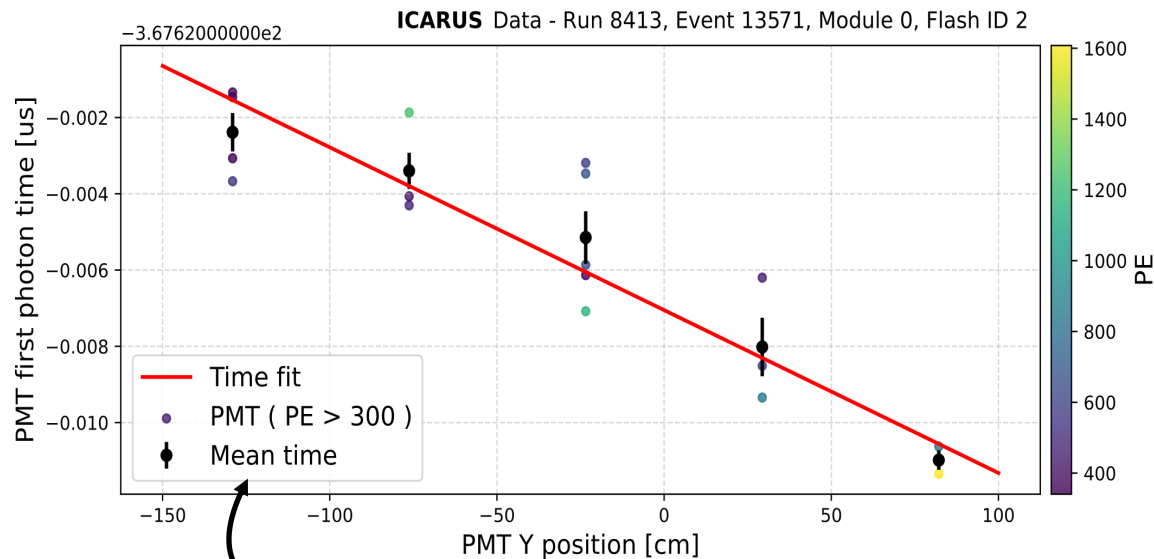
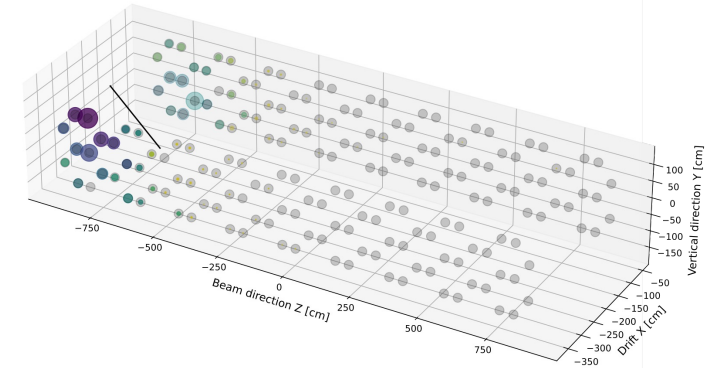

Mean between PMTs at the same quota on both wall removes x-dependence

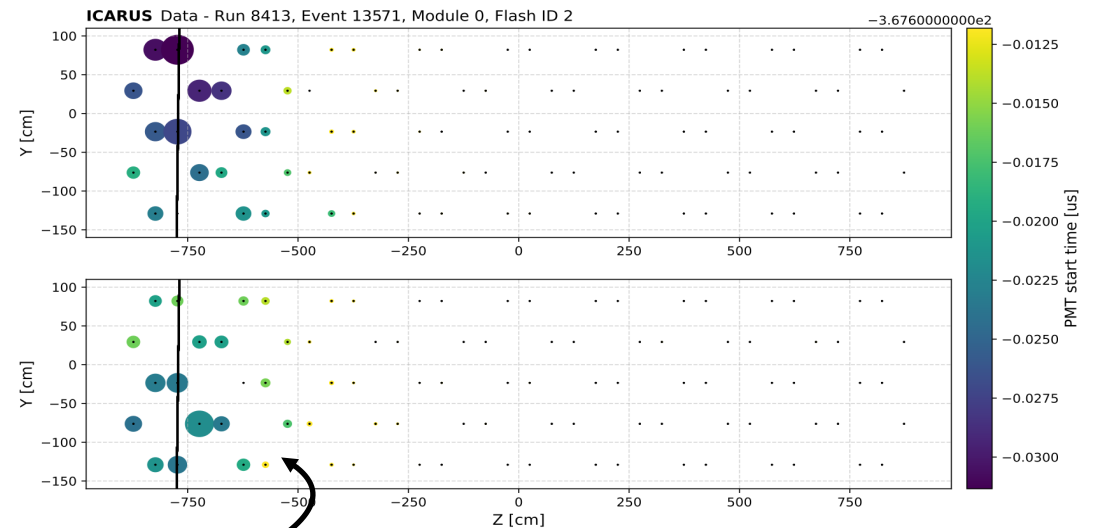

Cut on PE allows to exclude PMTs that are not in front of the track (z-dependence)

# Cosmics calibrations

- **Vertical cosmics:** linear relationship is expected between PMT y-coordinate and time.
- Deviations are due to z-position w.r.t the track or x-coordinate if track is closer to one wall.

..down to **300ps!**

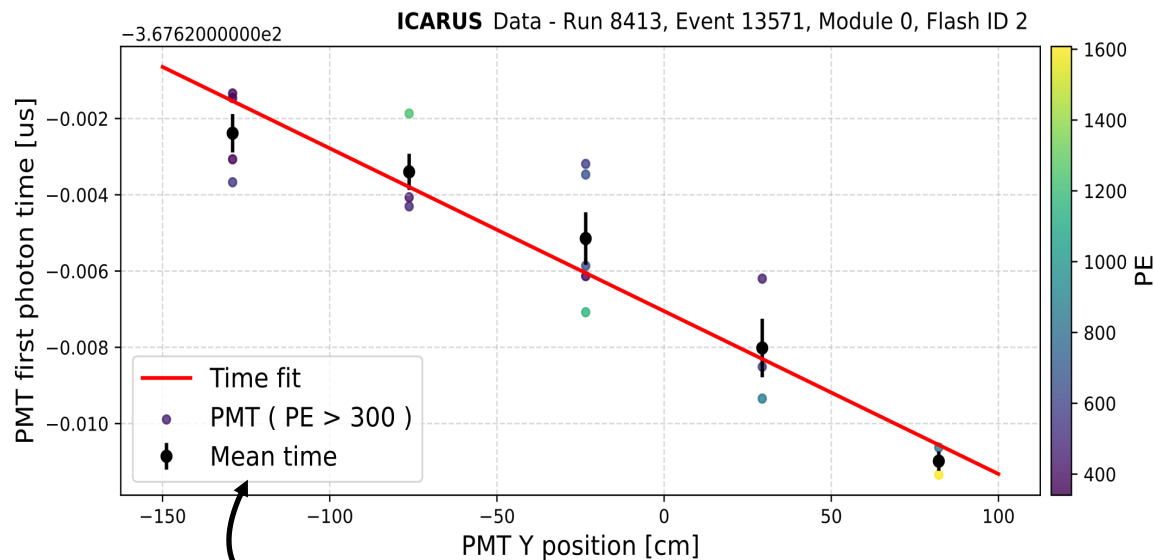

Mean between PMTs at the same quota on both wall removes x-dependence

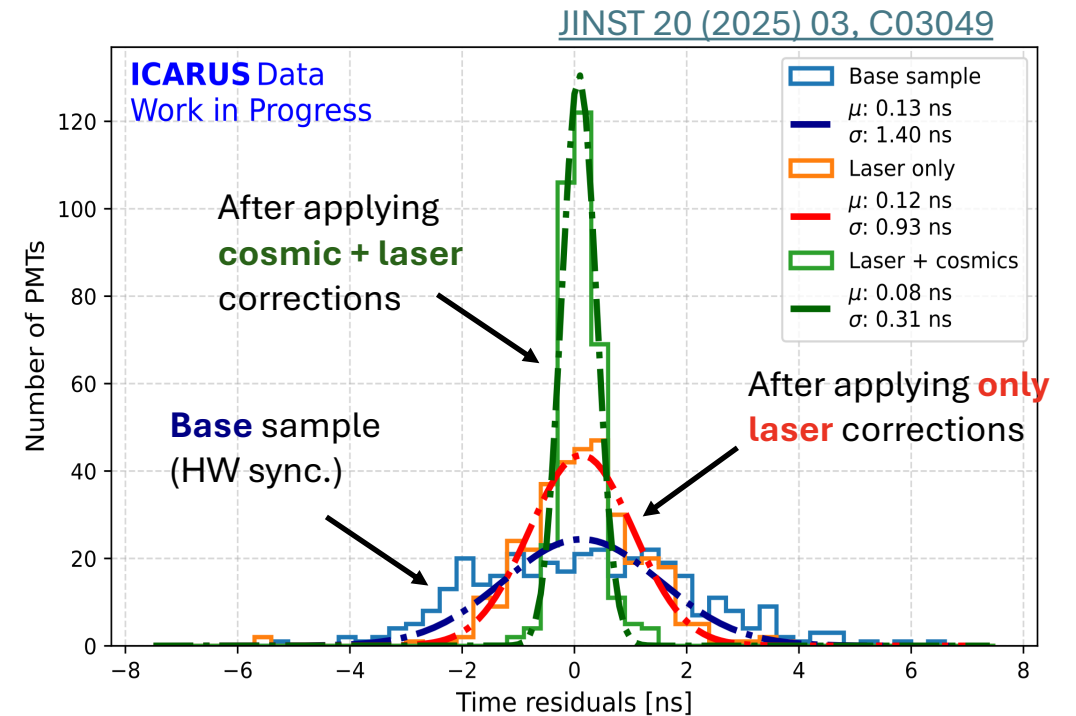

# Timing performance

- Precise timing equalization enable timing as a **selection tool**: rejecting background and selecting neutrinos!

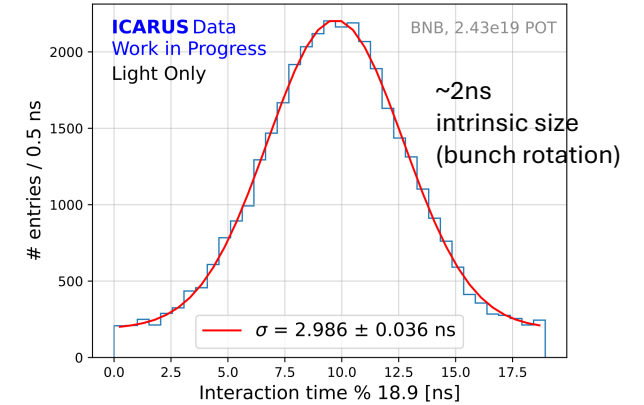
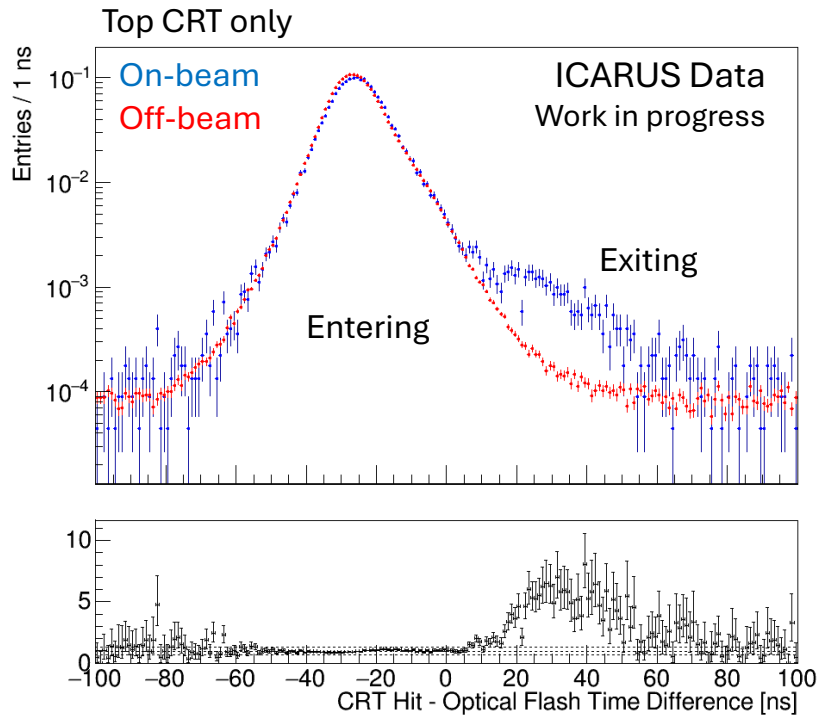

Beam bunch structure observed in data!

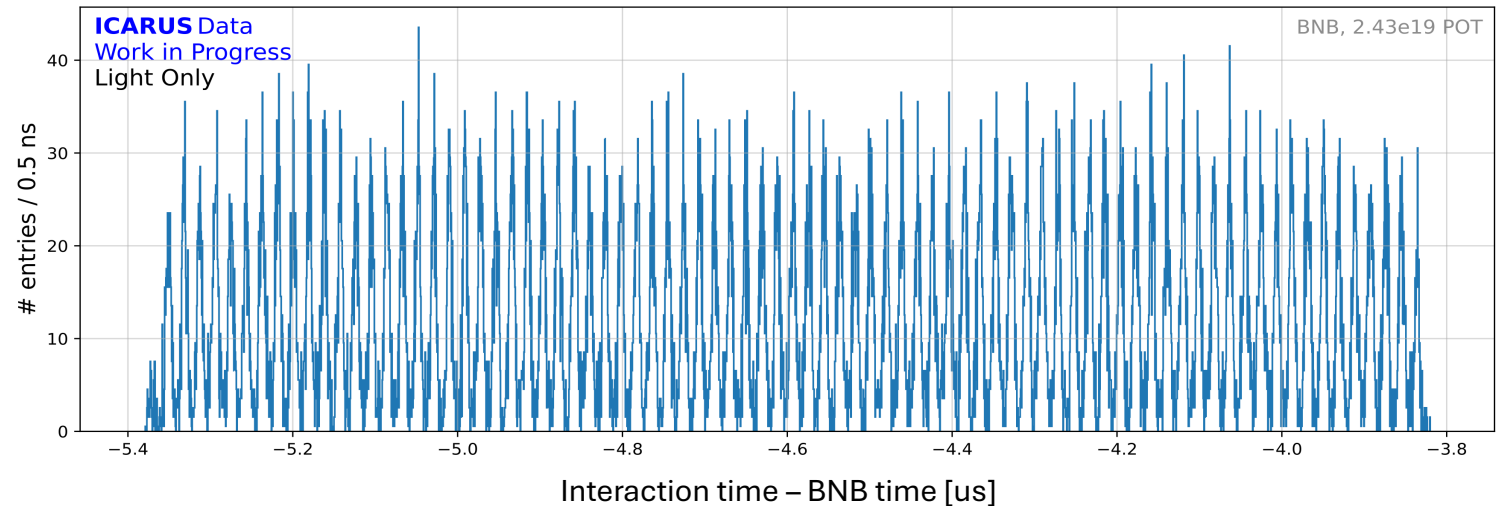

[JINST 20 \(2025\) 03, C03049](#)

# Summary

# Summary

- ICARUS has been operating smoothly at Fermilab for the last 5 years.
  - Large-scale liquid argon TPCs can deliver **stable and precise performance!**
- The large number of cosmic muons at the surface has been turned into “**standard candles**” for calibration.
- Successive correction steps have calibrated the **calorimetric energy scale** and equalized the **timing response**, enabling precise energy reconstruction and background rejection.
- Based on these performances, several ICARUS-only results are expected this year... **SBN-wide physics will follow!**

# Thank you!

This document was prepared by ICARUS using the resources of the Fermi National Accelerator Laboratory (Fermilab), a U.S. Department of Energy, Office of Science, Office of High Energy Physics HEP User Facility. Fermilab is managed by FermiForward Discovery Group, LLC, acting under Contract No. 89243024CSC000002.

# Noise modeling

- ICARUS warm electronics introduces **coherent noise** → removed via filter in signal processing
- Residual noise precisely characterized and modeled in the MonteCarlo. [JINST 20 \(2025\) 01, P01032](#)

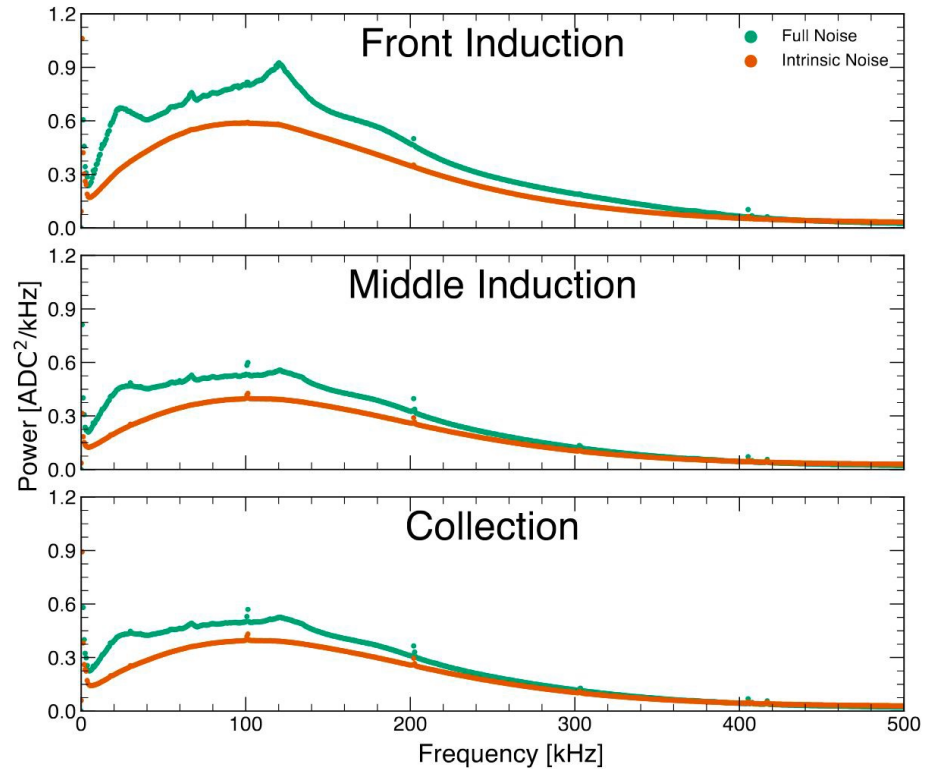
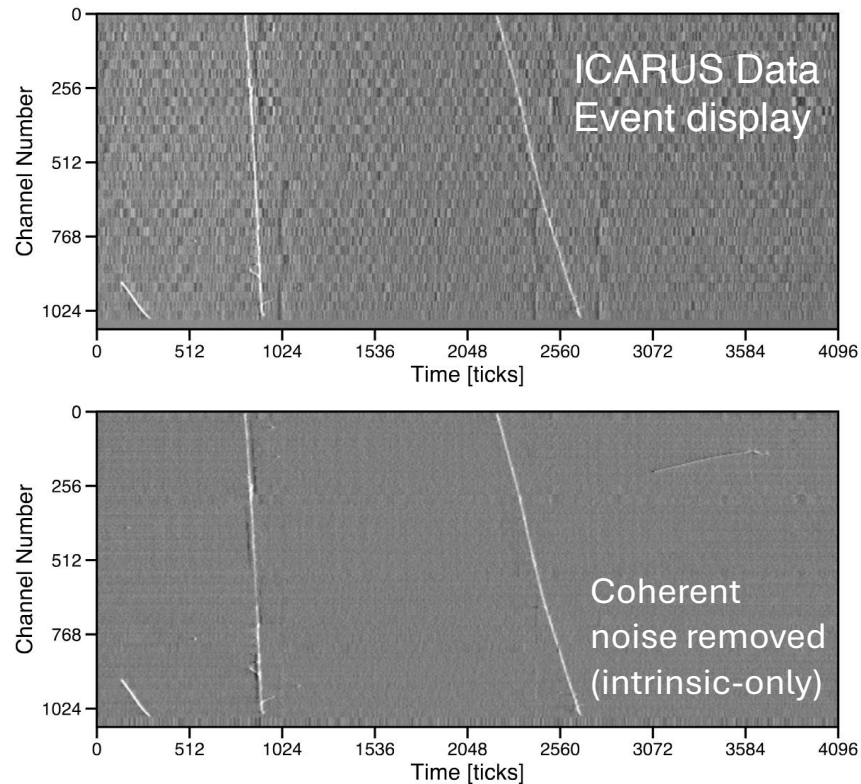

Noise power spectrum

# Electron lifetime

## ICARUS Electron Lifetime

