

## **DISCLAIMER**

**This report was prepared as an account of work sponsored by an agency of the United States Government. Neither the United States Government nor any agency thereof, nor any of their employees, makes any warranty, express or implied, or assumes any legal liability or responsibility for the accuracy, completeness, or usefulness of any information, apparatus, product, or process disclosed, or represents that its use would not infringe privately owned rights. Reference herein to any specific commercial product, process, or service by trade name, trademark, manufacturer, or otherwise does not necessarily constitute or imply its endorsement, recommendation, or favoring by the United States Government or any agency thereof. The views and opinions of authors expressed herein do not necessarily state or reflect those of the United States Government or any agency thereof. Reference herein to any social initiative (including but not limited to Diversity, Equity, and Inclusion (DEI); Community Benefits Plans (CBP); Justice 40; etc.) is made by the Author independent of any current requirement by the United States Government and does not constitute or imply endorsement, recommendation, or support by the United States Government or any agency thereof.**

## **Isokinetic Inlet Aboard Aircraft (INLETISOK-AIR) Instrument Handbook**

L. Goldberger

July 2020



## **DISCLAIMER**

This report was prepared as an account of work sponsored by the U.S. Government. Neither the United States nor any agency thereof, nor any of their employees, makes any warranty, express or implied, or assumes any legal liability or responsibility for the accuracy, completeness, or usefulness of any information, apparatus, product, or process disclosed, or represents that its use would not infringe privately owned rights. Reference herein to any specific commercial product, process, or service by trade name, trademark, manufacturer, or otherwise, does not necessarily constitute or imply its endorsement, recommendation, or favoring by the U.S. Government or any agency thereof. The views and opinions of authors expressed herein do not necessarily state or reflect those of the U.S. Government or any agency thereof.

# **Isokinetic Inlet Aboard Aircraft (INLETISOK-AIR) Instrument Handbook**

L Goldberger  
Pacific Northwest National Laboratory

July 2020

Work supported by the U.S. Department of Energy,  
Office of Science, Office of Biological and Environmental Research

## Acronyms and Abbreviations

AAF	ARM Aerial Facility
ARM	Atmospheric Radiation Measurement
CACTI	Cloud, Aerosol, and Complex Terrain Interactions
CAD	computer-aided design
CVI	counterflow virtual impactor
DOE	U.S. Department of Energy
DQO	Data Quality Office
G-1	Gulfstream-159
GUI	graphical user interface
IOP	intensive operational period
ISOK	isokinetic
PC	personal computer
PNNL	Pacific Northwest National Laboratory
SBIR	Small Business Innovation Research
USB	Universal Serial Bus

## Contents

Acronyms and Abbreviations .....	iii
1.0 Instrument Title .....	1
2.0 Mentor Contact Information.....	1
3.0 Vendor/Developer Contact Information.....	1
4.0 Instrument Description .....	1
5.0 Measurements Taken.....	2
6.0 Links to Definitions and Relevant Information.....	2
6.1 Data Object Description.....	2
6.2 Data Ordering.....	3
6.3 Data Plots .....	3
6.4 Data Quality .....	4
6.5 Instrument Mentor Monthly Summary.....	4
6.6 Calibration Database .....	4
7.0 Technical Specification .....	4
8.0 Instrument System Functional Diagram.....	5
9.0 Instrument Measurement Theory.....	6
10.0 Setup and Operation of Instrument.....	6
11.0 Software.....	7
12.0 Calibration .....	7
13.0 Maintenance.....	7
14.0 Safety.....	7
15.0 Citable References.....	7

## Figures

1 Left, image of isokinetic (ISOK) inlet on Brechtel’s website. Right, image of ISOK inlet on the G-1 aircraft (the top inlet is ISOK; the bottom is the counterflow virtual impactor [CVI] inlet). .....	2
2 Example of using data masks over the course of a flight from the Cloud, Aerosol, and Complex Terrain Interactions (CACTI) campaign in Argentina, 24 November, 2018. ....	3
3 Dryer performance on the inlet systems during the CACTI campaign. ....	4
4 CAD drawing of inlet with pick-off ports for cabin instrumentation. [1] .....	5
5 Schematic of the ISOK inlet with electronics schematic. [1].....	5

## 1.0 Instrument Title

Isokinetic Inlet aboard the aircraft designed by Brechtel (Hayward, California) and modified by Pacific Northwest National Laboratory (PNNL). Additional information can be found on the [manufacturer's website](#). An earlier model was used on the Gulfstream-159 (G-1) aircraft operated by the U.S. Department of Energy (DOE) Atmospheric Radiation Measurement (ARM) Aerial Facility (AAF) until 2019. A newer version of this instrument will be deployed on the replacement Challenger 850 aircraft. Modifications to the inlet involve making the software compatible with the aircraft's data acquisition system.

## 2.0 Mentor Contact Information

Mikhail Pekour  
[Mikhail.Pekour@pnnl.gov](mailto:Mikhail.Pekour@pnnl.gov)

## 3.0 Vendor/Developer Contact Information

Brechtel  
1789 Addison Way  
Hayward, California 94544  
Email: [bmi\\_info@brechtel.com](mailto:bmi_info@brechtel.com)  
Tel: 510-732-9723

## 4.0 Instrument Description

An isokinetic (ISOK) inlet is one that samples particles from the free stream of air at the same velocity as the free stream entering the tip of the inlet to ensure that the streamlines and particle trajectories are straight and 'isokinetic'. Super- and sub-isokinetic conditions skew the sampled particulate concentrations due to inertial effects around the tip of the inlet. A super-kinetic inlet has a greater sampling velocity than the free stream, bringing in air not only directly up front of it. In other words, the nearby streamlines curve inwards towards the inlet. Smaller particles follow the streamlines into the inlet, oversampling them, while larger particles have enough inertia not to be affected by the curvature in the streamlines, unsampled. In sub-kinetic conditions, the sample velocity is slower at the inlet than the free stream's velocity causing 'bunching' at the inlet's tip that curve the streamlines away from the inlet. In this case, the larger particles' trajectory is unaffected by the streamlines and they are sampled, while the smaller particles follow the streamlines away from the nozzle, leading to under-sampling.

Furthermore, inlets installed aboard aircraft must be sufficient distance away from the skin of the aircraft to truly sample from the free stream to avoid sampling effects and flow contamination. Inlets must also be installed at the appropriate angle to be aligned with the environmental airflow. Once installed on the aircraft, inlets also undergo extensive testing to ensure proper sampling.

Within the inlet, the sample air from the nozzle is slowed down in two stages by expansion via a diffuser to a velocity suitable to be sampled by instrumentation inside the cabin. The Brechtel isokinetic inlet has a

transmission efficiency > 90% for particle aerodynamic diameters less than 10 microns.[1] To reduce sampling bias, the inlet is outfitted with an aerodynamic twin-diffuser to prevent turbulent boundary-layer separation, passive pumping to remove the diffuser turbulent boundary layer, and a low-power blower to draw and actively control 150-lpm sample flow for the instruments.

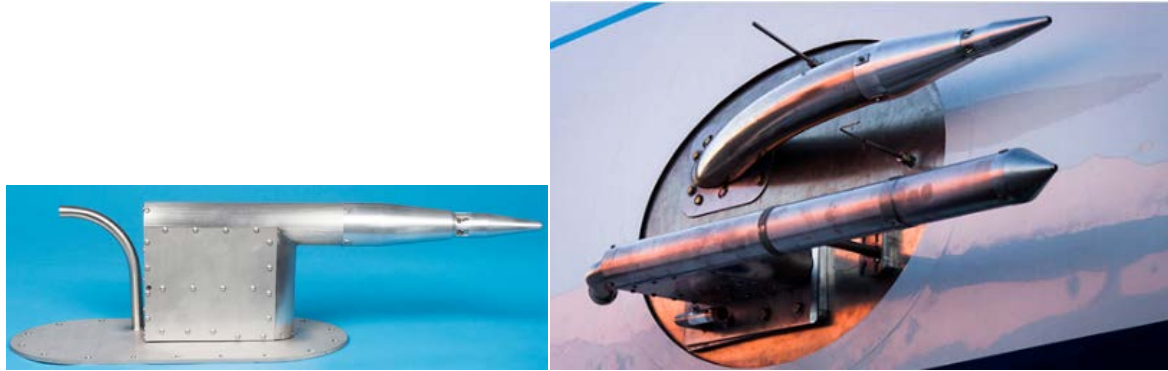

Figure 1. Left, image of isokinetic (ISOK) inlet on Brechtel’s website. Right, image of ISOK inlet on the G-1 aircraft (the top inlet is ISOK; the bottom is the counterflow virtual impactor [CVI] inlet).

## 5.0 Measurements Taken

The data presented here is primarily housekeeping data to provide the end user with basic environmental conditions. Included variables are cabin temperature, inlet temperature, inlet pressure, and inlet relative humidity. The data set OPC-AIR is the other inlet housekeeping data set providing information about coarse-mode aerosol size distribution that may be used for assessment of the integrity and transmission of the incoming sample aerosol. Please note that neither of these data sets are meant for scientific analysis and are published in the spirit of transparency to demonstrate the quality of data associated with the inlet.

Note that the instruments inside the cabin sample from a common manifold with excess flow exhausted downstream of the inlet. Usually, the sample distribution system on the aircraft is designed to allow a subset of instruments to switch between sampling via isokinetic and the CVI inlet, discussed in a separate handbook. The isokinetic inlet was designed for sampling clear air and the interstitial air between clouds. The CVI inlet samples and dries cloud elements and hydrometeors within clouds to allow cabin instrumentation to sample the core aerosol particles (ice or cloud condensation nuclei particles). The switch between inlets is performed manually by the cabin crew. The sampling inlet flag (ISOK versus CVI) is in the INLETCVI-AIR data set.

## 6.0 Links to Definitions and Relevant Information

Instrument manufacturer website: <https://www.brechtel.com/products-item/isokinetic-inlet-system/>

### 6.1 Data Object Description

Isokinetic inlet data submitted as a routine data set is named ‘aafinletisok’. Data submitted as intensive operational period (IOP) data will have the name ‘inletisok-air’. Before 2016, this data set was submitted

on a campaign-by-campaign basis as IOP data. Data since 2016 has been submitted as a routine data set. Data is available in both netCDF format and ASCII format (as an [ICARTT](#) file).

The recorded data fields include:

- Cabin Temperature
- Inlet Temperature
- Inlet Pressure
- Inlet Relative Humidity.

On the G-1, the output data was recorded with 1-Hz resolution with the M300 data acquisition system. The Challenger aircraft will use an updated data system, but the ISOK datastream will remain the same. Separate data files are normally started for preflight tests and for each flight.

## 6.2 Data Ordering

Data from the ISOK inlet can be ordered from <https://www.arm.gov/capabilities/instruments/inletisok-air>. Data are organized by measurement location and campaign.

## 6.3 Data Plots

No plots are available for these data on Data Discovery; however, these data can be used for data masking.

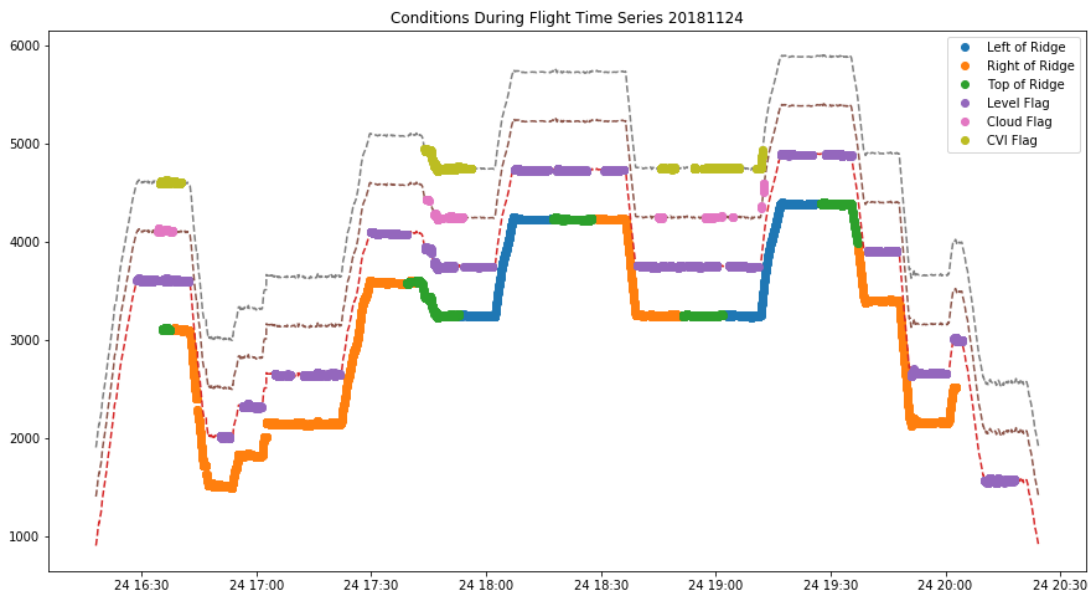
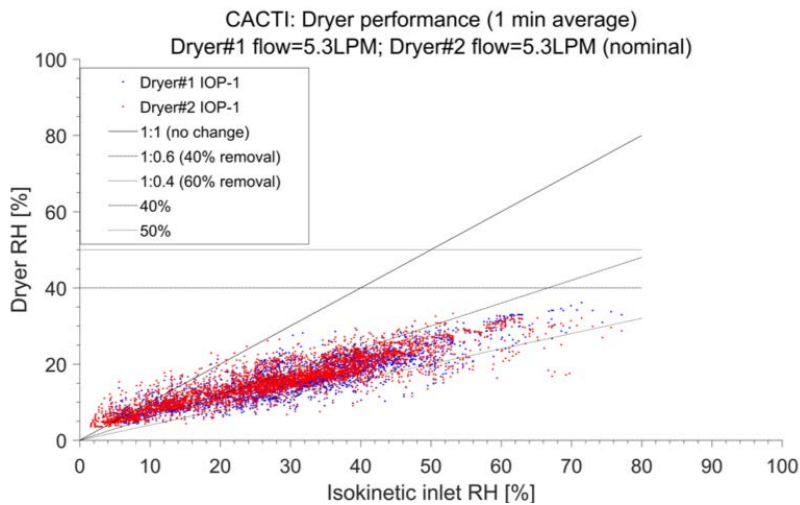

Figure 2. Example of using data masks over the course of a flight from the Cloud, Aerosol, and Complex Terrain Interactions ([CACTI](#)) campaign in Argentina, 24 November, 2018. When the CVI flag is false, cabin instrumentation is sampling from the ISOK inlet. This sampling aligns with periods of clear air.

## 6.4 Data Quality

Data quality evaluation involves automatic flagging of data based on criteria developed by instrument mentors. Automatic data quality checks performed by the ARM Data Quality Office (DQO) ensure the temperature, pressure, and relative humidity are within normal levels. The instrument mentor performs a more vigorous data quality check before data publication to ensure particle transmission is not biased from cases such as transmission loss and dryer performance.



**Figure 3.** Dryer performance on the inlet systems during the CACTI campaign.

## 6.5 Instrument Mentor Monthly Summary

The instrument is currently not in use while the Challenger 850 aircraft is being modified for research.

## 6.6 Calibration Database

Information on this subject is maintained by AAF's Director of Engineering.

## 7.0 Technical Specification

PARAMETER	VALUE	UNIT
Particle aerodynamic diameter size range	0.005-10	micron
Sample flow at diffuser tip (at 100 m/s*)	300	Liters per minute
Sample flow to cabin	150	Liters per minute
Maximum sample flow to instruments	100	Liters per minute
Control and data acquisition frequency	1	Hz
Anti-icing power	900	Watts @ 28 VDC
Rack- mountable electronics chassis size	19 x 6.5 x 12 (48.25 x 16.5 x 30.5)	Inches (centimeters)
Electronics chassis weight	20 (9)	Lb (kg)
Total system weight	70 (31.75)	Lb (kg)
Operating temperature range	-40 to 45	C
Operating pressure range (absolute)	200- 1000	mb

\* this is the research speed at which the aircraft operates.

## 8.0 Instrument System Functional Diagram

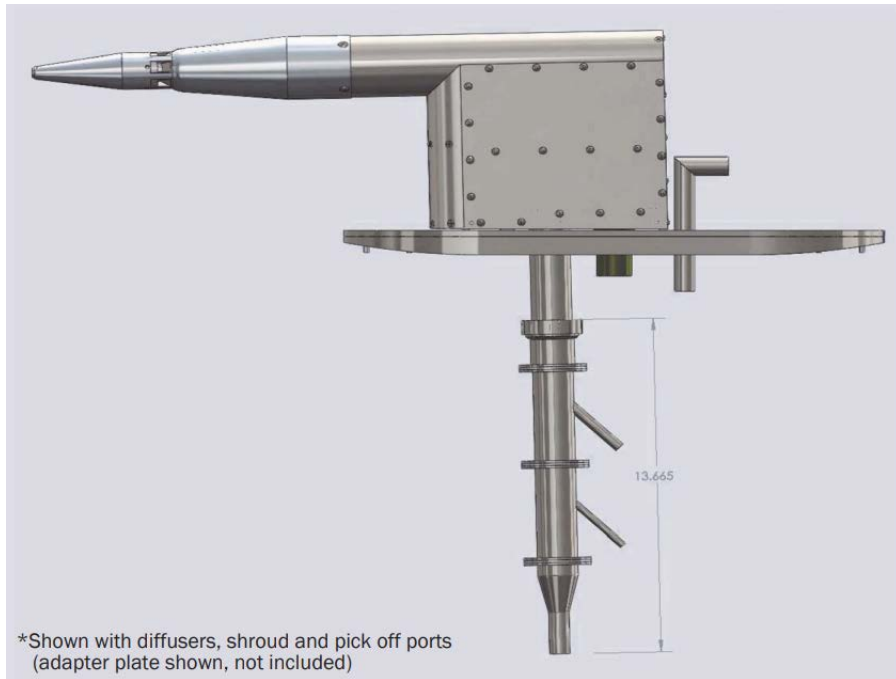

**Figure 4.** CAD drawing of inlet with pick-off ports for cabin instrumentation.[1]

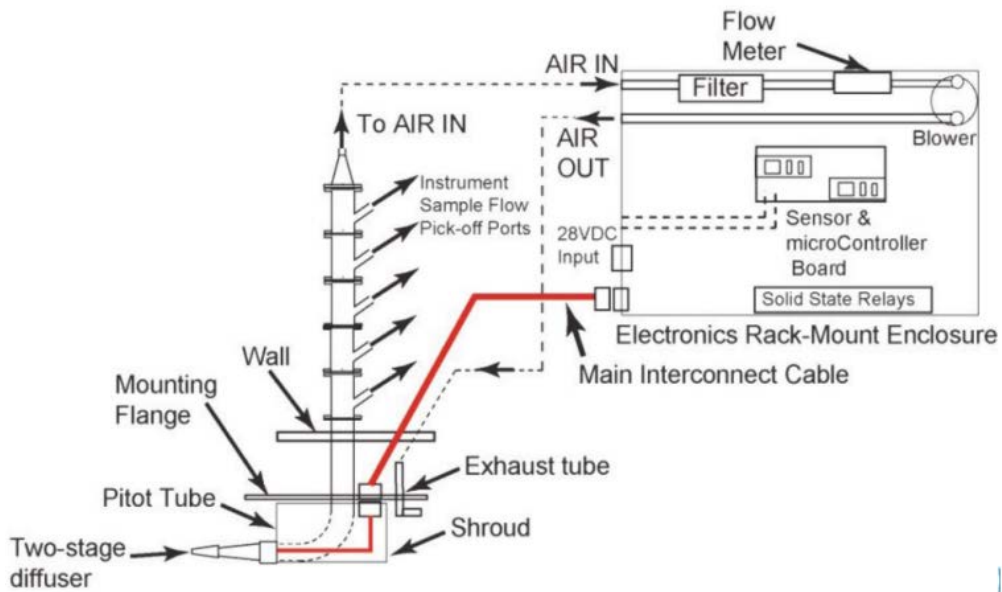

**Figure 5.** Schematic of the ISOK inlet with electronics schematic.[1]

## 9.0 Instrument Measurement Theory

Aerosol instrumentation tends to be large and heavy, and thus generally must be deployed inside the cabin of the aircraft. Great attention must be made that atmospheric aerosol is transported into the cabin and sampled by the instrumentation in such a way as to not disturb its properties. The isokinetic inlet system is designed for sampling aerosol in clear or interstitial air to accomplish this goal. The sampling efficiency is determined by properties of the inlet's aspiration, entrance, and transmission.[2,3] Aspiration efficiency is the ratio of particle concentrations inside the inlet and in the free stream, which is directly related to the velocity of air entering the inlet's nozzle matching the velocity of the air approaching the nozzle, hence why it is called isokinetic. The importance of the inlet's entrance relates to its bluntness, as the probe tip can generate flow separation and turbulence inside the inlet resulting in particle loss more disproportionately affecting larger particles whose larger inertia prevents them from following streamlines.[3] Finally, inlet transmission efficiency describes the loss of particles within the inlet due to "sedimentation, turbulent deposition, inertial deposition from bends in the inlet, and diffusion".[2,3,4] To minimize this effect as well as residence time in the inlet, a large amount of flow is passed through the subsampling tube, the majority of which is exhausted downstream while a small fraction is sampled. To reduce the velocity of the incoming airstream to be sampled by the instrumentation, a diffuser can be put in line before sampling. A diffuser in this case is a duct that increases the area in the direction of flow that allows the compressible fluid, in this case air laden with aerosol, to increase in temperature, pressure, and density while decreasing velocity.

The two-stage diffuser isokinetic inlet was developed for and deployed on the G-1 aircraft as part of the DOE Small Business Innovation Research (SBIR) program (DEFG02-00ER82939).[5] The inlet nozzle is placed at a suitable distance away from the skin of the body of the aircraft to avoid air contamination effects from surface drag and turbulent eddies, but at the same time is close enough to the fuselage such that the stream of air is unaffected by the prop wash of the propellers. On the G-1 this distance was 8 inches away from the fuselage. The angle of attack of the inlet is in line with the directional flow of air so that the streamlines are unimpeded as they enter the nozzle.

After the nozzle and two diffusers, the probe contained a shallow (less than 90°) bend so that it can be inserted through a window plate on the right (starboard) side of the aircraft. The Brechtel isokinetic inlet reported transmission efficiency is above 90% for particles with aerodynamic diameter less than 10 microns.[1] The first prototype of the inlet installed on the G-1 aircraft had a 50% cutoff near 1.5 μm.[6] A total of 300 lpm was sampled by the inlet and was actively reduced to 150-lpm sample flow for the instruments.[5] Overall, the sampling probe was designed to ensure incoming flow streamlines remained isokinetic, flow through the probe remained steady and absent of strong turbulent eddies, and the shape of a given particle size distribution did not change significantly throughout the probe.

## 10.0 Setup and Operation of Instrument

The inlet was set up when it was first installed on the G-1 aircraft. Power to this instrument and its data recording was controlled by the M300 SEA data acquisition system.

## 11.0 Software

Adapted from Bechtel's website:

*“The ISO inlet operating software provides real-time displays of current parameter values, including Air Speed, Tip Volume Flow, Measured Volume Flow, and Volume Flow Setpoint. You can quickly change the total instrument sample flow drawn from the sample pick-off ports and the control software will automatically adjust the amount of flow needed to maintain isokinetic sampling conditions. Operating pressure and various temperatures are monitored to maintain proper flow and anti-icing system control.*

*Two distinct flow control modes are available: direct flow control by varying the speed of the built-in high-speed blower, or flow control using the blower coupled with a low-pressure drop-control valve. The two techniques broaden the dynamic pressure range over which the system can be operated. Control software is built into the micro-controller inside the control chassis, so no external PC is required to operate the system. Graphical user interface (GUI) software is provided to run on a user-supplied PC. The PC must be running Windows 7 or later system software and have at least one free USB port. The GUI provides timeline plots of all major operating parameters and allows key system settings to be easily changed.”*

Modifications were made by the instrument mentor to adapt for use on the AAF aircraft.

## 12.0 Calibration

The calibration procedures and records are maintained between Brechtel and the instrument mentor.

## 13.0 Maintenance

The inlet should be cleaned before every campaign. This is suitable enough for most sampling regimes, though an accelerated cleaning schedule is recommended for environments with particularly heavy aerosol loadings, such as flying through smoke.

## 14.0 Safety

Not applicable. Inlet installed at a height such that operators on the ground should be clear of the inlet at all times.

## 15.0 Citable References

[1] Brechtel Isokinetic Inlet. <https://www.brechtel.com/products-item/isokinetic-inlet-system/> Accessed June 29, 2020.

[2] Hermann, M, F Stratmann, M Wilck, and A Wiedensohler. 2000. “Sampling characteristics of an aircraft-borne aerosol inlet system.” *Journal of Atmospheric and Oceanic Technology* 18(1): 7–19, [https://doi.org/10.1175/1520-0426\(2001\)018<0007:SCOAAB>2.0.CO;2](https://doi.org/10.1175/1520-0426(2001)018<0007:SCOAAB>2.0.CO;2)

- [3] Huebert, BJ, G Lee, and WL Warren. 1990. “Airborne aerosol inlet passing efficiency measurement.” *Journal of Geophysical Research – Atmospheres* 95(D10): 16369–16381, <https://doi.org/10.1029/JD095iD10p16369>
- [4] Baron, PA, and K Willeke. 2005. *Aerosol Measurement: Principles, Techniques, and Applications*. 2nd ed. John Wiley & Sons Inc. Hoboken, New Jersey, USA.
- [5] Zaveri, R, CM Berkowitz, FJ Brechtel, MK Gilles, JM Hubbe, JT Jayne, LI Kleinman, A Laskin, S Madronich, TB Onasch, MS Pekour, SR Springston, JA Thornton, AV Tivanski, and DR Worsnop. 2009. “Nighttime chemical evolution of aerosol and trace gases in a power plant plume.” *Journal of Geophysical Research – Atmospheres* 115(D12): D12304, <https://doi.org/10.1029/2009JD013250>
- [6] Brechtel, FJ. 2003. Description and Assessment of a New Aerosol Inlet for the DOE G-1 Research Aircraft. Final Technical Report of work performed by BMI under contract #0000058843 to Brookhaven National Laboratory, August 2003.



U.S. DEPARTMENT OF  
**ENERGY**

---

Office of Science