



ASME ES 2025

19th International Conference on
Energy Sustainability

Pilot Development Progress to Demonstrate Electric Thermal Energy Storage (ETES) Using Low-Cost Particles

Zhiwen Ma, Shin Young Jeong, Munjal Shah, Jason Hirschey,
Umang Patel, Emre Ustuner, Rashad Kayal, Nicholas Fergerson
(National Renewable Energy Laboratory)

This presentation was produced when the laboratory operated as the National Renewable Energy Laboratory (NREL). The laboratory is now the National Laboratory of the Rockies (NLR).

Why Long Duration Energy Storage (LDES)?

Enhance grid resiliency

- Shift to variable renewable energy generation will create supply/demand imbalances
- Energy **storage** needed to provide **balancing** on different timescales:

Daily – peak hours

Primary technology: **Li-ion batteries**

Multiday – weather anomalies

Primary technology: **Long Duration Energy Storage**

Multiweek – seasonal mismatches

Primary technology: **Hydrogen**

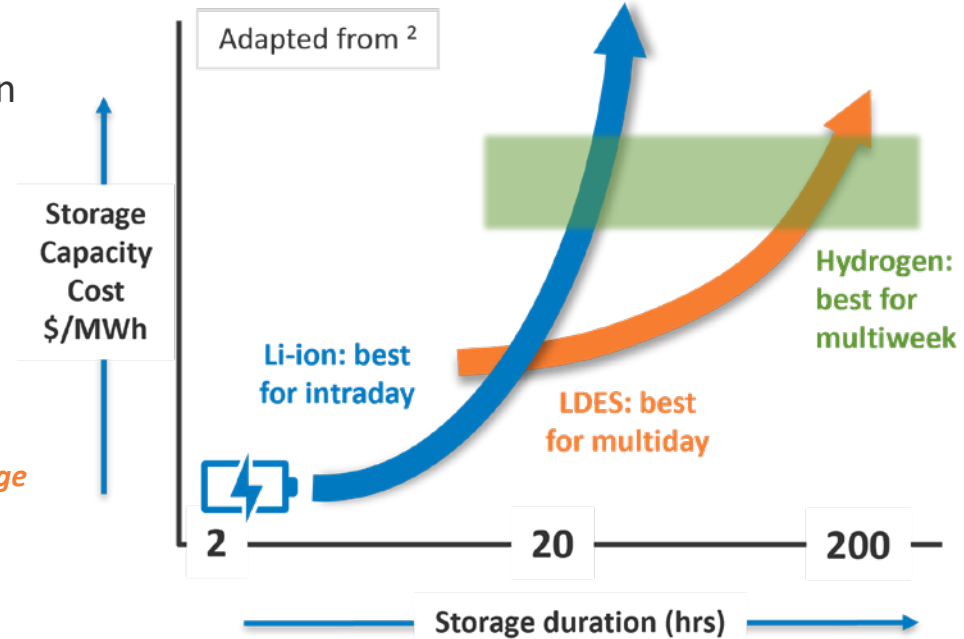

¹www.whitehouse.gov/briefing-room/statements-releases/2021/04/22/fact-sheet-president-biden-sets-2030-greenhouse-gas-pollution-reduction-target-aimed-at-creating-good-paying-union-jobs-and-securing-u-s-leadership-on-clean-energy-technologies/

²LDES Council, McKinsey & Company. "Net-zero power: Long duration energy storage for a renewable grid"

Comparison of LDES Technologies

	Particle ETES	Compressed Air Energy Storage	Pumped Hydro	Li-Ion Battery	Flow Battery
Size (MW _e)	10–400	150–500	>100	0.1–50	1–20
Duration (hours)	>10 to 100	>6 to 10	>6 to 10	1–4	4–8
Round-trip efficiency	40%–70%	40% -60%	70%–85%	85%	70%
Response time	Minutes (warm start)	Minutes	Minutes	Seconds-minutes	Seconds-minutes
Life cycle	++	++	++	+	–
Power system cost*	\$700–\$1,500/kW	\$1,000–1,500/kW	\$600–\$2,500/kW	\$300+/kWh _e	\$500/kWh _e
Energy storage cost	\$4–\$10/kWh_e	\$150–\$300/kWh _e	>\$60/kWh _e		
Siting flexibility	++	–	–	++	++

ETES Benefits: Large capacity, low storage cost, flexible siting:

- Separating power system and storage favors LDES to expand storage capacity economically.
- With spinning reserve at hot start, ETES can respond rapidly to synchronize grid demand.

Technology developed under (ARPA-E) DAYS Program from 2019-2023

Accomplishments & Impact

- Developed system components and projected that the component designs meet the cost and performance targets for demonstration and technology to market.
- The ENDURING LDES system provides power for several days by low-cost, high-performance storage cycles, addressing grid storage needs by enabling large-scale grid integration of variable renewables like wind and solar, thereby increasing their grid value.
- Five awarded patents, 8 published journal papers, and a book chapter.

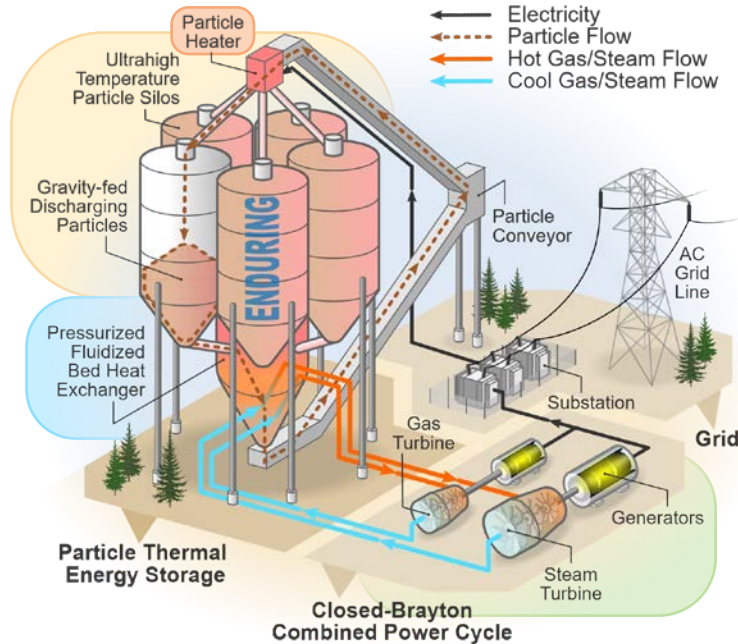

Economic Long-Duration Electricity Storage by Using Low-Cost Thermal Energy Storage and High-Efficiency Power Cycle (**ENDURING**)

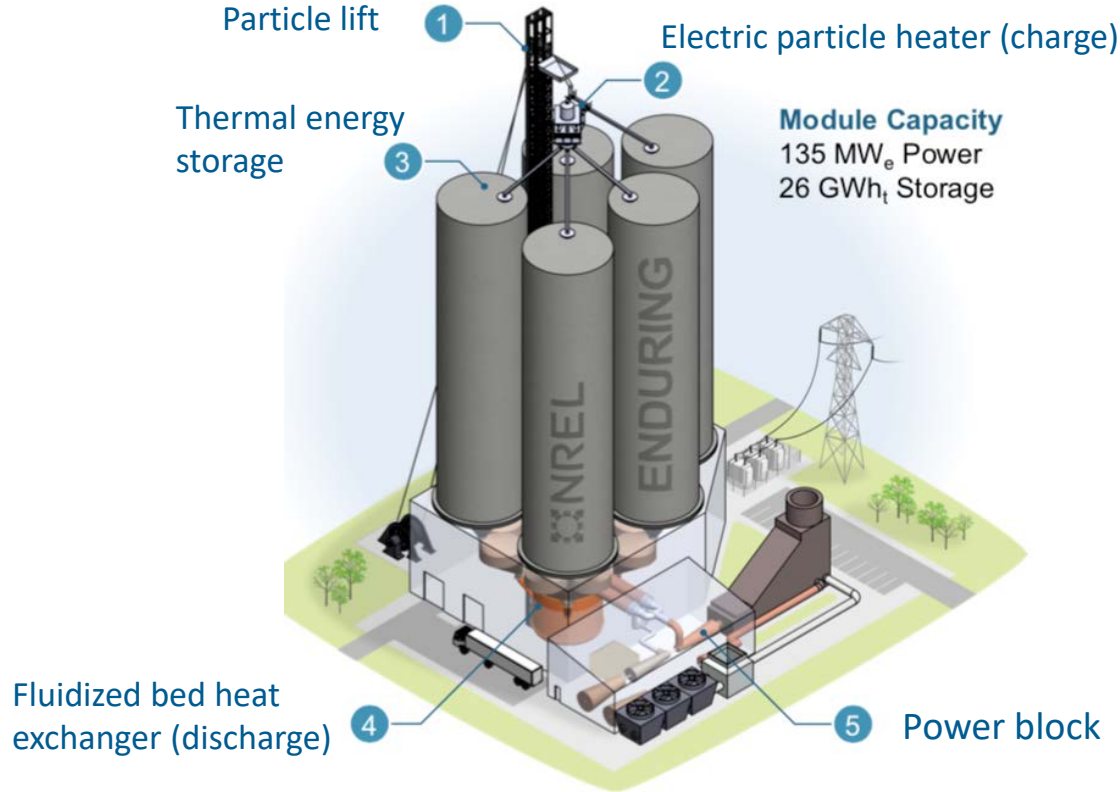

ENDURING System:

- Particle thermal energy storage for low-cost, large capacity long-duration energy storage.
- **Scalable for 0.01-20 GWh storage, 10-400 MW_e generation**

Decoupling energy storage and power generation ensures independent variation of power capacity and storage duration, serving scalable storage needs

Development History and Technology Gap

Project Impact:

- Validate system integration & controls
- Verify innovative charge heater and discharge fluidized bed heat exchanger designs at commercially relevant scale
- Advance technology to TRL 6

Demonstration and Integration
Addressing Customer Questions

2023-



2021-2024

SETO Projects on Particle CSP

- Pumped Thermal Energy Storage
- Enclosed Particle Solar Receiver
- Industry Process Heat



2012-2019

SETO SunShot and Gen3 CSP develop Particle-Based CSP

- Developed particle-based storage
- Supercritical CO₂ power cycle

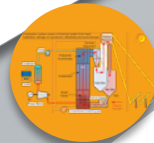

2019-2022

ARPA-E DAYS ENDURING Project

- ETES system design with laboratory prototypes.

1980s-1990s

B&W demos 70 MW
Pressurized Fluidized Bed
(PFB) System

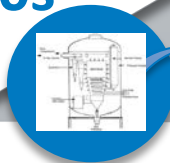

Technology impacted
by downturn of coal.

Electric-Thermal Energy Storage for LDES @ ARIES

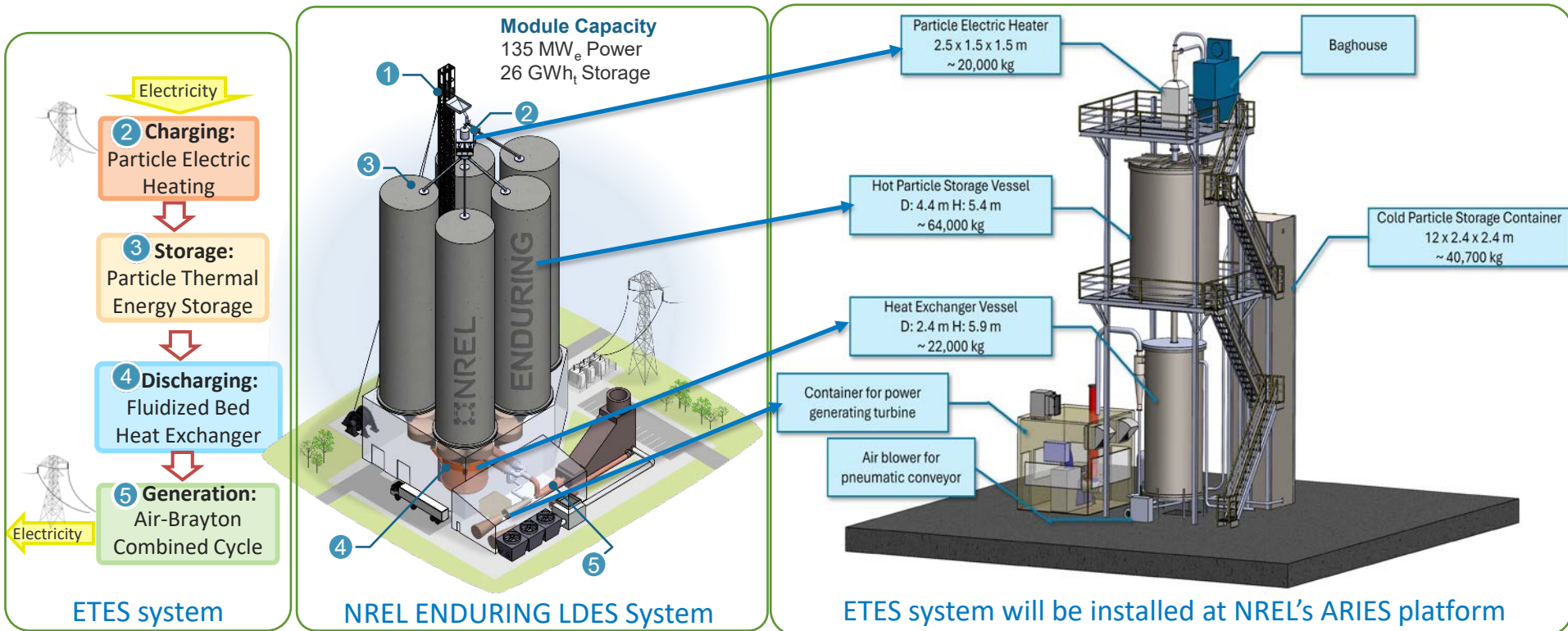

NREL's ARIES Platform for Energy Storage Research

ARIES configuration and ETES addition

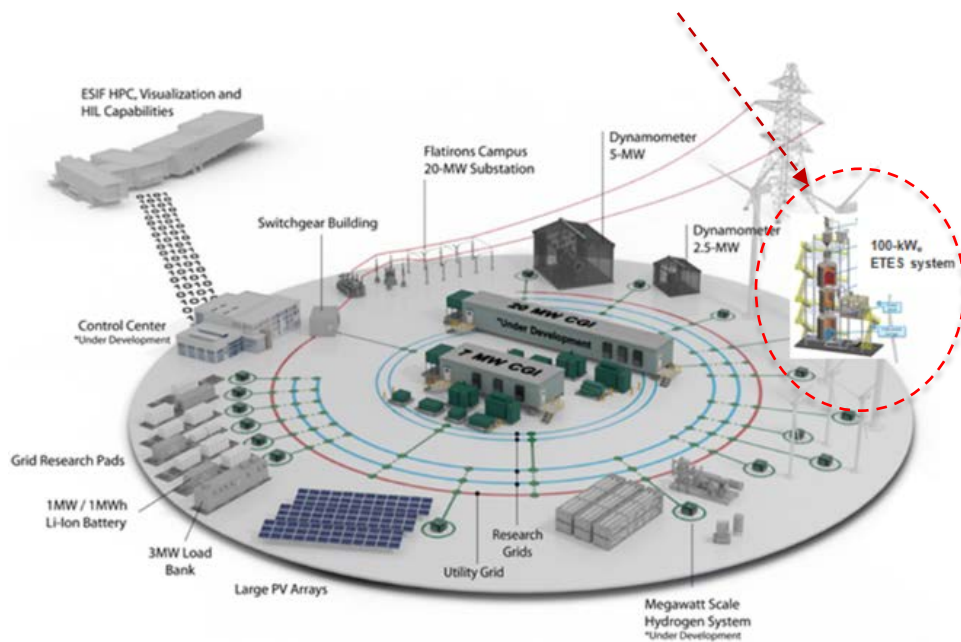

Demonstration of grid integration, hybrid integration, and mitigation of grid congestion and disruptions.



NREL ARIES (Advanced Research on Integrated Energy Systems) Facility

- Wind and solar generation (2 MW)
- Electrochemical batteries (1 MW)
- Specialized grid computational simulators
- Controllable grid interface at 7 MW and (soon) 20 MW
- Secure controls and communications with a cybersecurity emulation network
- Community-scale energy system controls and power electronics integration

100-kW_e Demonstration System

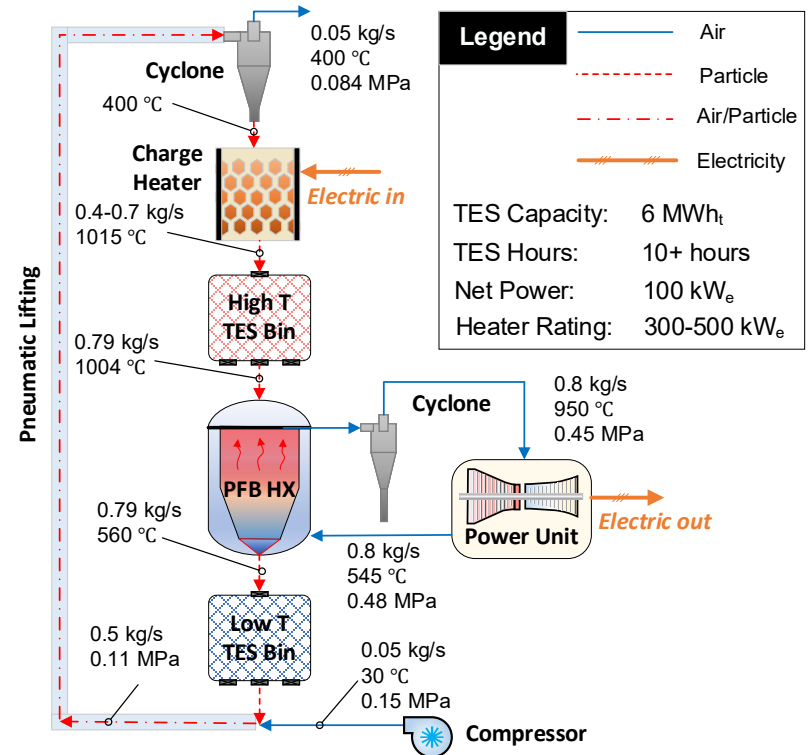
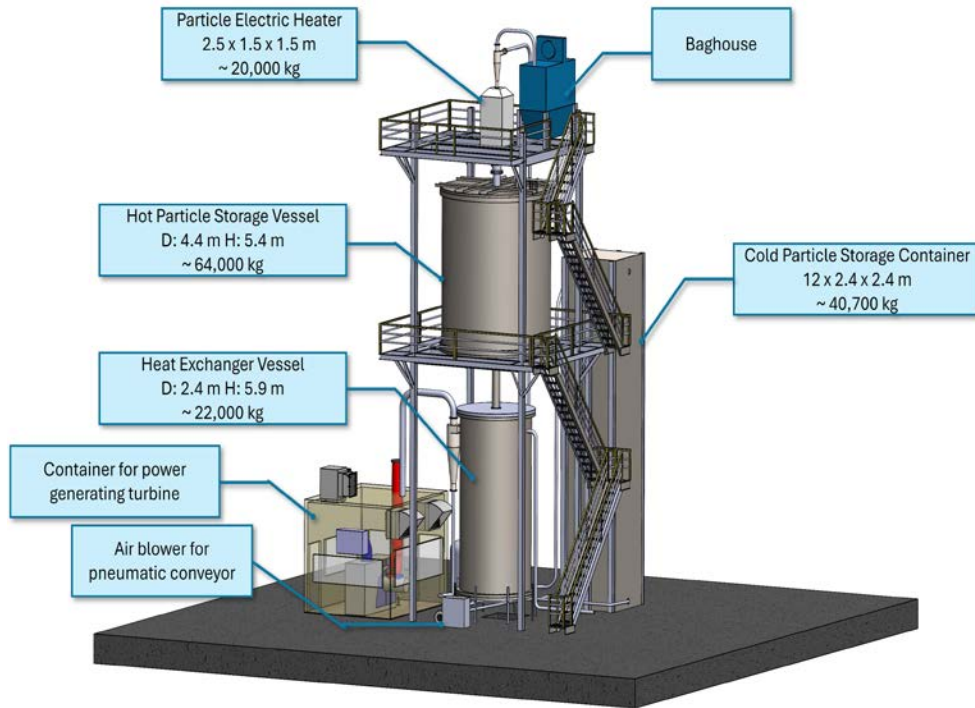

Major Components: Electric Particle Heater

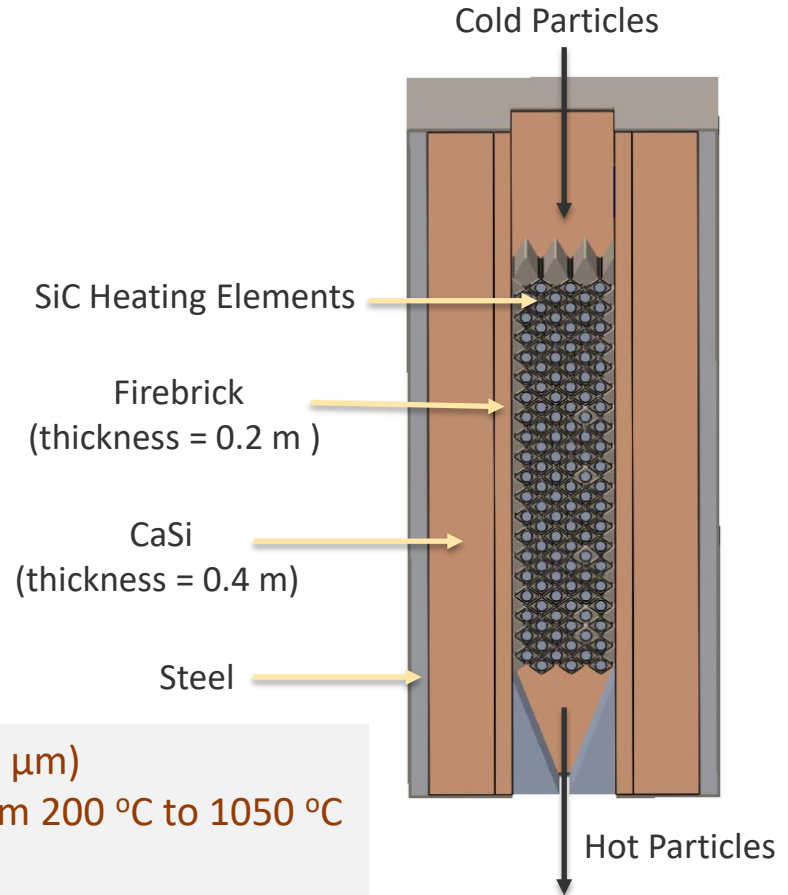
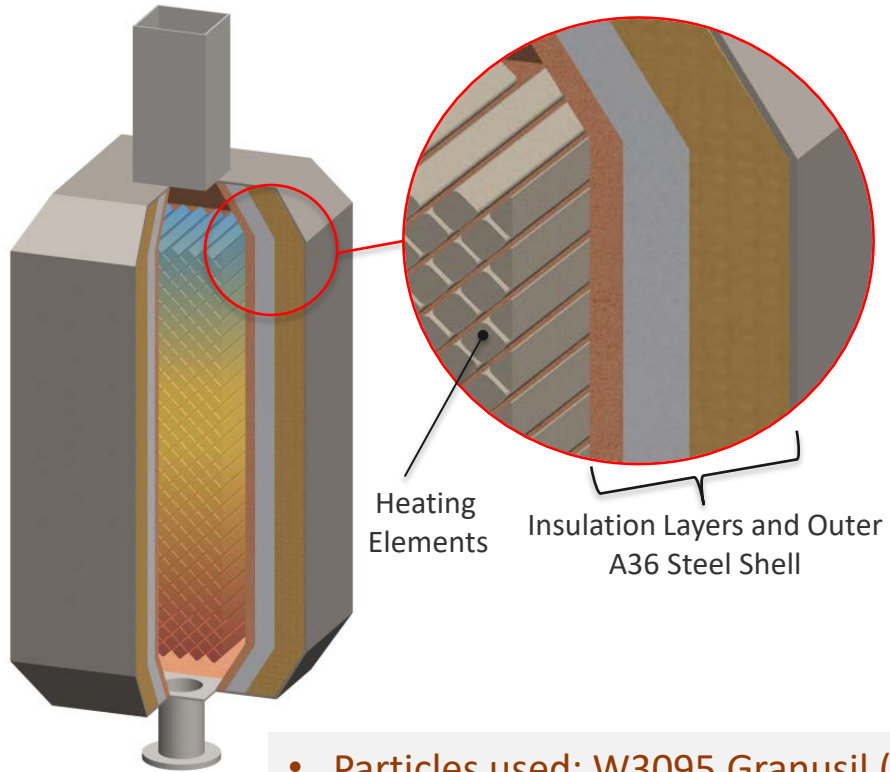

- Particles used: W3095 Granusil (825 μm)
- Target particle temperature rise: from 200 $^{\circ}\text{C}$ to 1050 $^{\circ}\text{C}$
- Heating elements material: SiC
- Insulation material: Firebrick, CaSi

Major Components: Hot Storage Bin

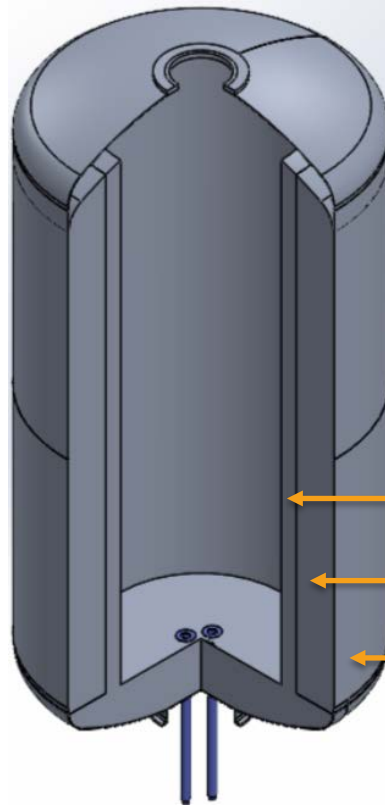
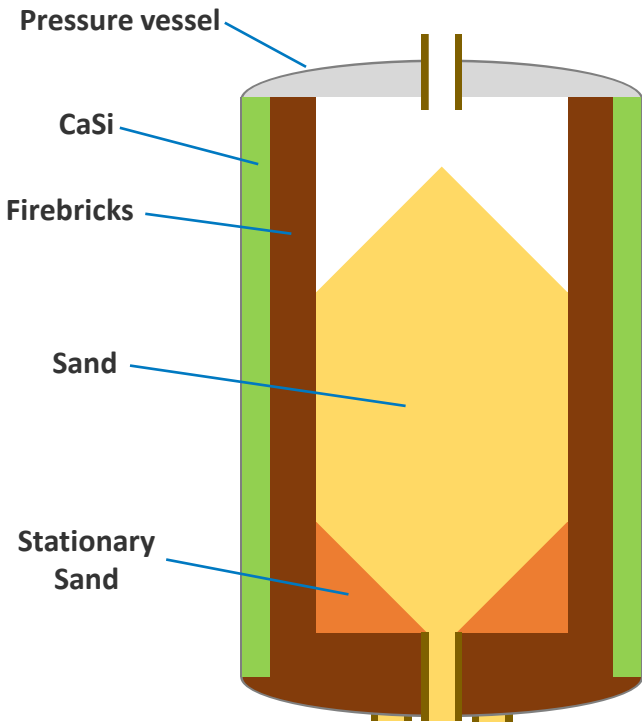

- Storage capacity: $\sim 32,000$ kg
- Hot sand temperature: 1015 °C
- Total energy stored: 33.36 GJ
- Storage duration: 25 hrs
- Heat loss (over 24 hours): 3%
- Pressure: 0.48 Mpa
- Inner height: 5.4 m
- Inner diameter: 2.16 m

Firebrick layer (thickness = 0.2 m)

CaSi layer (thickness = 0.5 m)

Steel

Major Components: Fluidized Bed Heat Exchanger

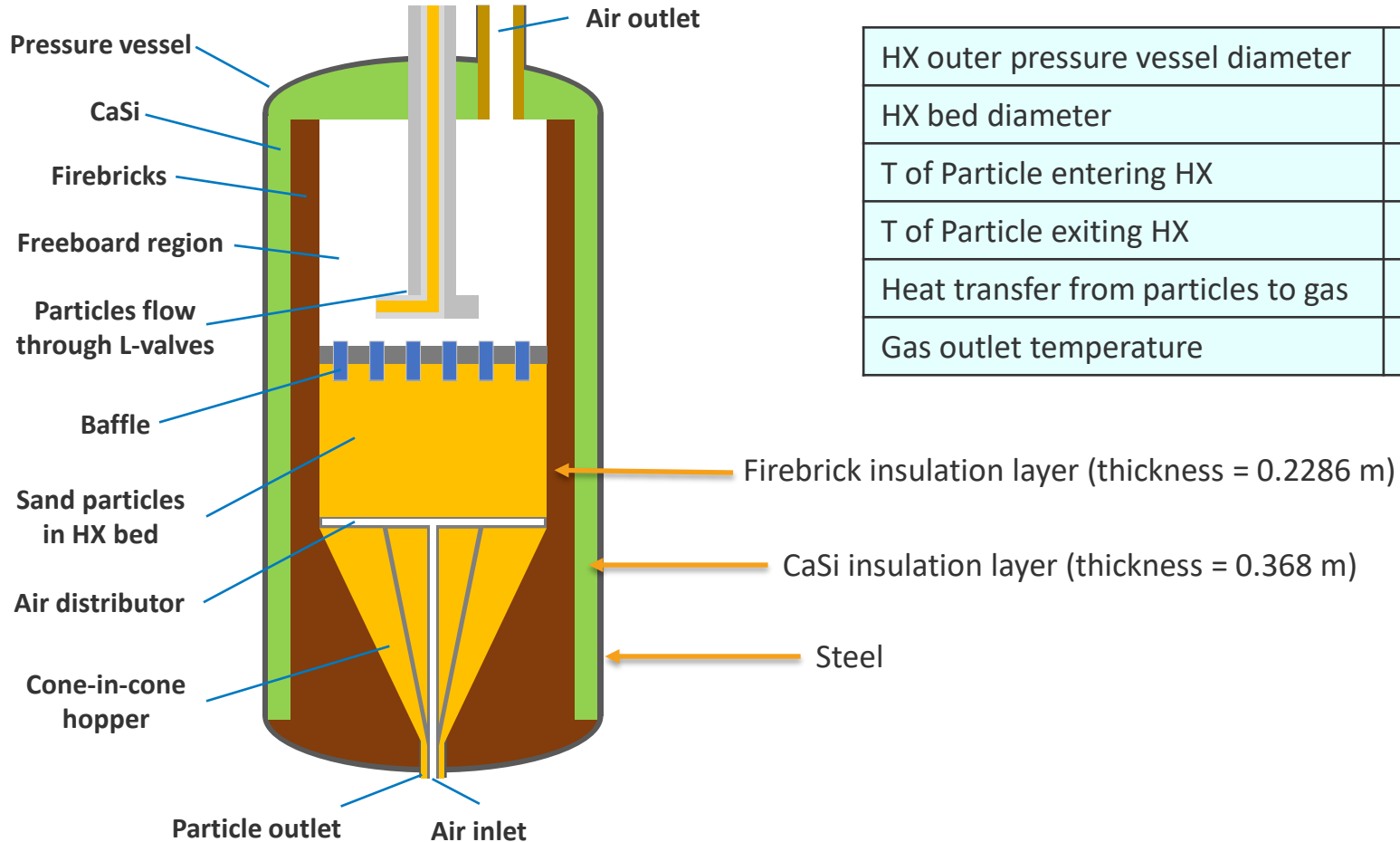

HX outer pressure vessel diameter	3.22 m
HX bed diameter	2 m
T of Particle entering HX	1018.13 °C
T of Particle exiting HX	268.17 °C
Heat transfer from particles to gas	670.4 kW
Gas outlet temperature	1003.13 °C

Major Components: Fluidized Bed Heat Exchanger

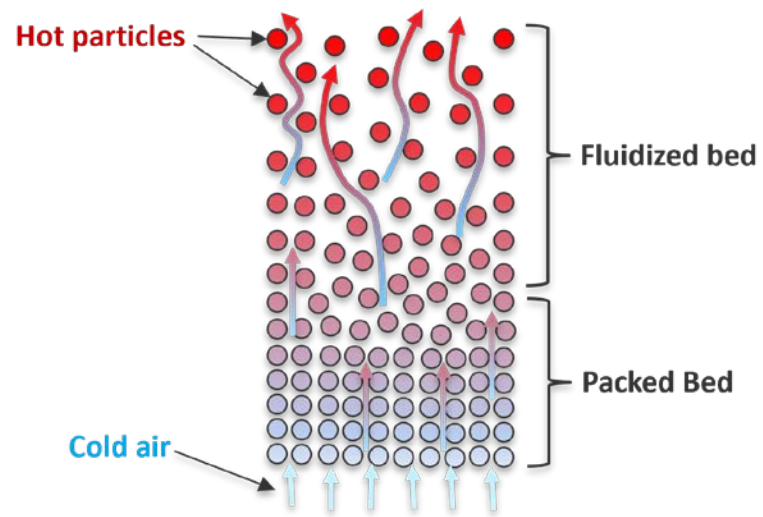
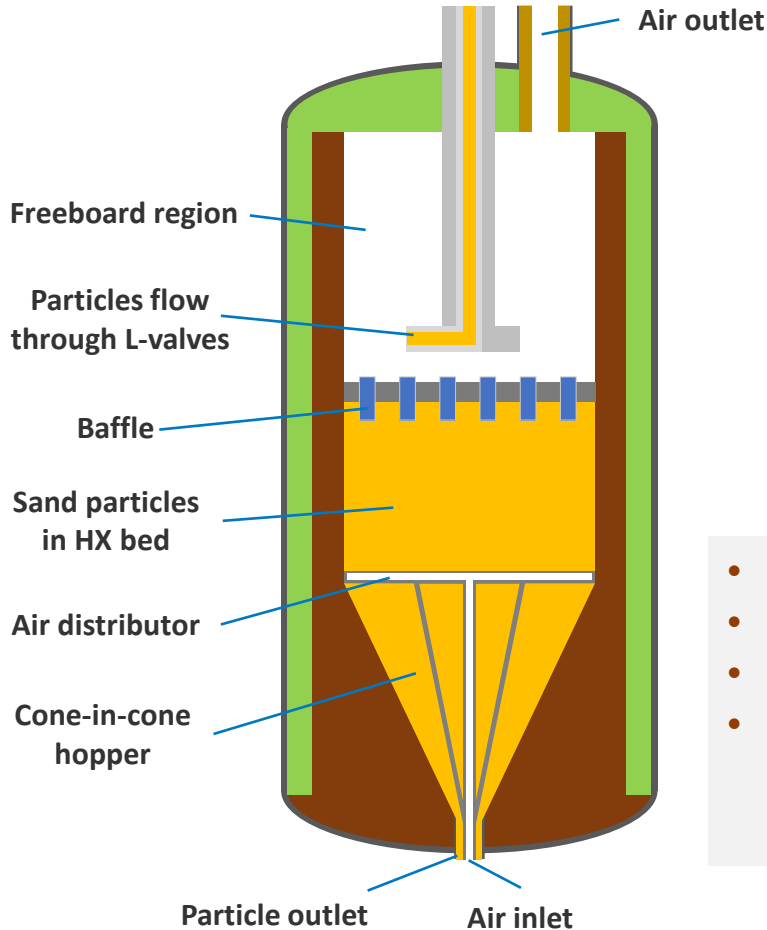

- Direct contact fluid-solid fluidized bed heat exchanger
- Mixed bed operation
- Thermal stratification along the bed height
- Using larger particles to increase fluidizing flow rate without significantly changing the fluidization regime and achieving higher heat transfer.

Major Components: Cold Storage Bin

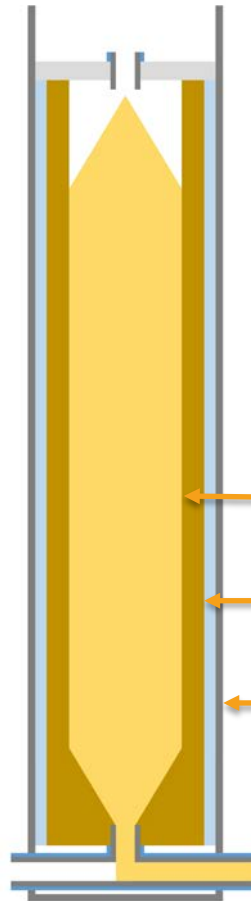
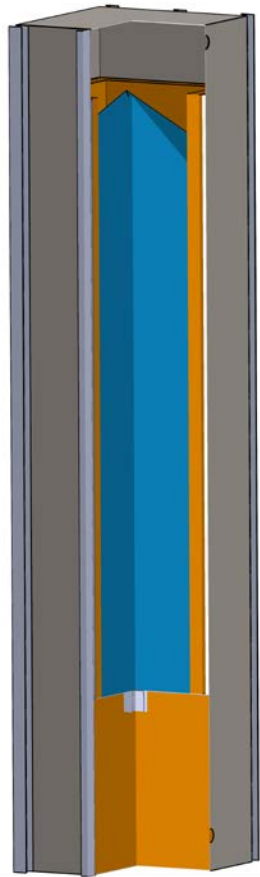

- Shipping container used as cold particle storage
- Insulated internally using firebrick and mineral wool
- Stored particle mass: 32 tons
- Particle temperature entering CSB: $\sim 263.4^{\circ}\text{C}$

Firebrick insulation layer (thickness = 0.3 m)

Mineral wool insulation layer (thickness = 0.15 m)

Structural Steel



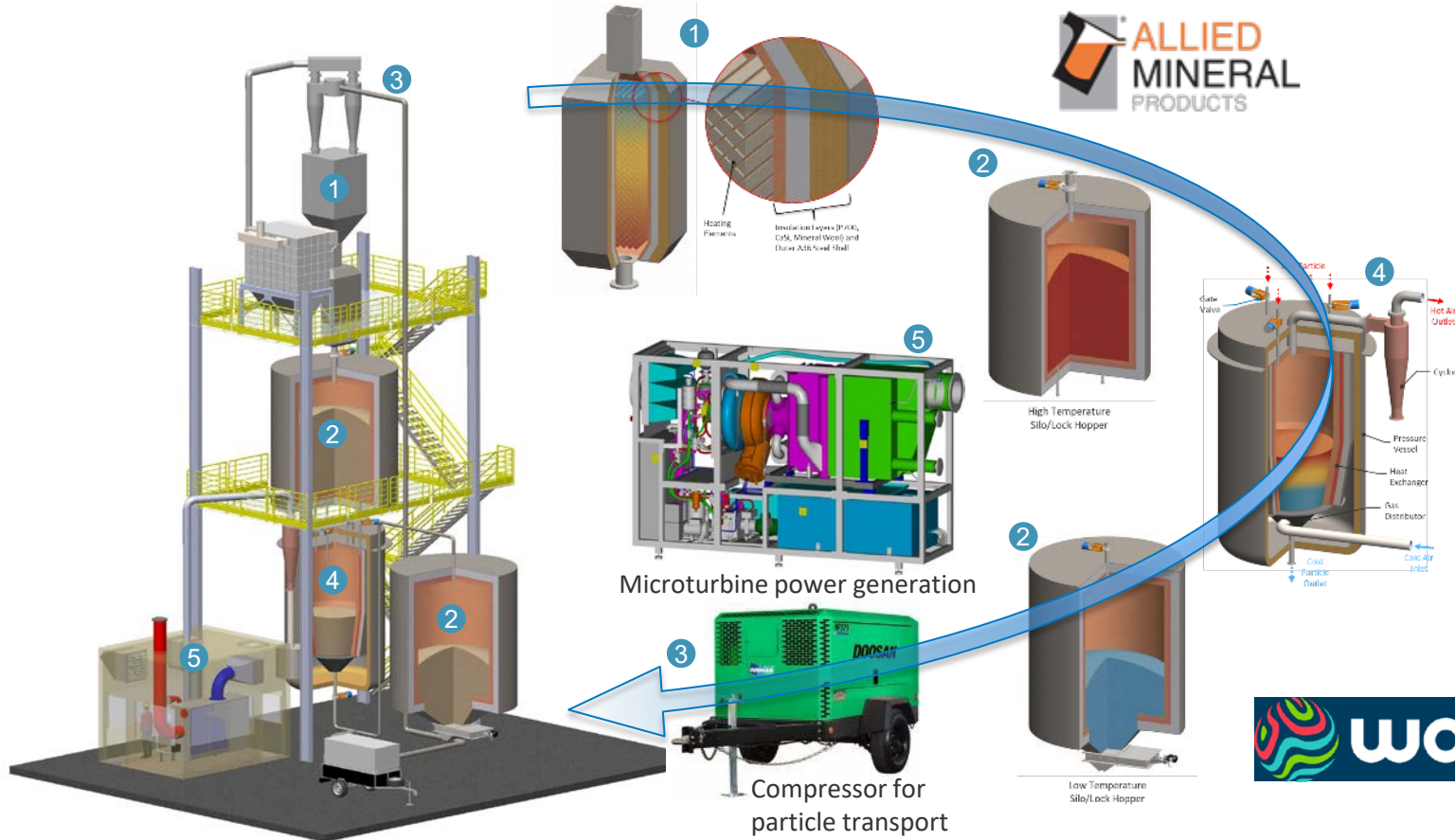

Component Installation and System Integration



Microturbine power generation

Compressor for particle transport

Project Timeline

Tasks	2024	2025	2026	2027	2028	2029
50% component design and 30% site design						
100% component design and site/infrastructure design						
Equipment production and delivery, construction, and installation, Test readiness verification and commissioning						
Operations and Testing						



Questions?

Contacts:

Umang Patel

Umang.Patel@nrel.gov

Zhiwen Ma, Principal Investigator

Zhiwen.Ma@nrel.gov

www.nrel.gov

**We acknowledge funding support from the
Department of Energy!**

NLR/PR-5700-95800

This work was authored by NREL for the U.S. Department of Energy (DOE), operated under Contract No. DE-AC36-08GO28308. Funding provided by U.S. Department of Energy Office of Energy Efficiency and Renewable Energy and Office of Clean Energy Demonstration. The views expressed in the article do not necessarily represent the views of the DOE or the U.S. Government. The U.S. Government retains and the publisher, by accepting the article for publication, acknowledges that the U.S. Government retains a nonexclusive, paid-up, irrevocable, worldwide license to publish or reproduce the published form of this work, or allow others to do so, for U.S. Government purposes.