

DISCLAIMER

This report was prepared as an account of work sponsored by an agency of the United States Government. Neither the United States Government nor any agency thereof, nor any of their employees, makes any warranty, express or implied, or assumes any legal liability or responsibility for the accuracy, completeness, or usefulness of any information, apparatus, product, or process disclosed, or represents that its use would not infringe privately owned rights. Reference herein to any specific commercial product, process, or service by trade name, trademark, manufacturer, or otherwise does not necessarily constitute or imply its endorsement, recommendation, or favoring by the United States Government or any agency thereof. The views and opinions of authors expressed herein do not necessarily state or reflect those of the United States Government or any agency thereof. Reference herein to any social initiative (including but not limited to Diversity, Equity, and Inclusion (DEI); Community Benefits Plans (CBP); Justice 40; etc.) is made by the Author independent of any current requirement by the United States Government and does not constitute or imply endorsement, recommendation, or support by the United States Government or any agency thereof.



Pacific Northwest National Laboratory Facility Radionuclide Emission Points and Sampling Systems

December 2021

JM Barnett
SF Snyder

DISCLAIMER

This report was prepared as an account of work sponsored by an agency of the United States Government. Neither the United States Government nor any agency thereof, nor Battelle Memorial Institute, nor any of their employees, makes **any warranty, express or implied, or assumes any legal liability or responsibility for the accuracy, completeness, or usefulness of any information, apparatus, product, or process disclosed, or represents that its use would not infringe privately owned rights.** Reference herein to any specific commercial product, process, or service by trade name, trademark, manufacturer, or otherwise does not necessarily constitute or imply its endorsement, recommendation, or favoring by the United States Government or any agency thereof, or Battelle Memorial Institute. The views and opinions of authors expressed herein do not necessarily state or reflect those of the United States Government or any agency thereof.

PACIFIC NORTHWEST NATIONAL LABORATORY
operated by
BATTELLE
for the
UNITED STATES DEPARTMENT OF ENERGY
under Contract DE-AC05-76RL01830

Printed in the United States of America

Available to DOE and DOE contractors from
the Office of Scientific and Technical Information,
P.O. Box 62, Oak Ridge, TN 37831-0062

www.osti.gov

ph: (865) 576-8401

fox: (865) 576-5728

email: reports@osti.gov

Available to the public from the National Technical Information Service
5301 Shawnee Rd., Alexandria, VA 22312

ph: (800) 553-NTIS (6847)

or (703) 605-6000

email: info@ntis.gov

Online ordering: <http://www.ntis.gov>

Pacific Northwest National Laboratory Facility Radionuclide Emission Points Units and Sampling Systems

JM Barnett
SF Snyder

December 2021

Prepared for
the U.S. Department of Energy
under Contract DE-AC05-76RL01830

Pacific Northwest National Laboratory
Richland, Washington 99354

Summary

Battelle–Pacific Northwest Division operates numerous research and development laboratories in Richland, Washington. U.S. Department of Energy (DOE) contracts to Battelle include Richland facilities on the DOE Hanford Site and the Pacific Northwest National Laboratory (PNNL) – Richland Campus that have the potential for radionuclide air emissions. The PNNL contract also includes DOE operations at the PNNL-Sequim Campus, in Sequim, Washington, where there is also the potential for radionuclide air emissions. This document is a periodic update that describes current PNNL facility emission units and sampling systems.

The National Emission Standard for Hazardous Air Pollutants (NESHAP [40 Code of Federal Regulations 61, Subpart H]) requires an assessment of all emission units that have the potential for radionuclide air emissions.¹ Emission units are registered with the State of Washington. Potential emissions from emission units are assessed annually by PNNL staff members. Sampling, monitoring, and other regulatory compliance requirements are designated based on the potential-to-emit dose criteria based on facility identified potential impact categories using a graded approach to sampling and monitoring as prescribed by the regulations. The purpose of this document is to describe the facility radionuclide air emission sampling program and provide current and historical facility emission unit system performance, operation, and design information.

For sampled emission units, the building, exhaust unit, control technologies, and sample extraction details are provided. Additionally, applicable configuration drawings, figures, and photographs are included. For non-sampled emission units, emission estimation and radionuclide source details are provided. Site-wide permits for the lowest potential impact category are described. Deregistered/transitioned emission unit details are also provided as necessary for at least 5 years post-closure/transition.

Currently, five emission units are sampled continuously for particulate radionuclides at PNNL-managed facilities on the PNNL-Richland Campus (3 of the 5) and on the Hanford Site (2 of the 5). Four of these units have sampling systems that comply with the American National Standards Institute/Health Physics Society (ANSI/HPS) N13.1–2011 standard for sampling from stacks and ducts of nuclear facilities, and the fifth is grandfathered and compliant with the older ANSI N13.1–1969 standard. In addition, the PNNL-managed Hanford Site 325 Building EP-325-01-S stack is sampled continuously for emissions of tritium. No emissions sampling is required for the single PNNL-Sequim Campus licensed emission unit in Sequim, Washington.

¹ EPA – U.S. Environmental Protection Agency. 2002. “National Emission Standards for Emissions of Radionuclides Other Than Radon from Department of Energy Facilities.” 40 CFR 61, Subpart H, Government Printing Office, Washington, D.C.

Acronyms, Abbreviations, and Terms

ALARACT	as low as reasonably achievable control technology
ANSI	American National Standards Institute
BARCT	best available radionuclide control technology
CAM	continuous air monitor; also used for continuous air monitoring (system)
CFD	computational fluid dynamics
CFR	Code of Federal Regulations
cfm	cubic feet per minute
DEPO	Deposition Computer Software Code
deregistered	A report of closure has been transmitted to the Washington State Department of Health indicating that operations of an emission unit with the potential-to-emit (PTE) radioactive materials has ceased.
DOE	U.S. Department of Energy
EDE	effective dose equivalent
EM	Effluent Management
EMS	Environmental Management System
EPA	U.S. Environmental Protection Agency
EPRP	Environmental Protection and Regulatory Programs. This designator to procedures supersedes other designators such as EM, EMS, and EMSD that have historically been used.
ESTD	Energy Science and Technology Directorate
ETD	Environmental Technology Directorate
EU ID	Emission Unit Identification (number)
F&O	Facilities & Operations
FSD	Fundamental Science Directorate
HDI	How Do I? (PNNL standards-based management system)
HEPA	high-efficiency particulate air (filter)
HPS	Health Physics Society
HTO	condensable tritium; tritium as water vapor
HT	non-condensable tritium
HVU	HEPA filtered vacuum radioactive air emission unit
ID	identification; may also be used as “inside diameter” for piping measurements
inactive	Although the emission unit is still registered, there are no operations occurring with the PTE radioactive materials through the emission unit.
major	An emission unit with the potential to contribute greater than or equal to 0.1 millirem (mrem)/yr dose to the maximally exposed individual (MEI) off site.

minor	An emission unit with the potential to contribute less than 0.1 mrem/yr dose to the MEI off site.
LSL-II	Life Sciences Laboratory II
MCRL	Marine and Coastal Research Laboratory
MEI	maximally exposed individual
MEP	mechanical, electrical, and plumbing
mrem	millirem
MSL	Marine Sciences Laboratory
N/A	not available
NESHAP	National Emission Standards for Hazardous Air Pollutant
NOC	notice of construction
NRC	U.S. Nuclear Regulatory Commission
PIC	potential impact category
PNNL	Pacific Northwest National Laboratory
PSF	Physical Sciences Facility
PTE	potential-to-emit
PTRAEU	Portable/Temporary Radioactive Air Emission Unit
QA	quality assurance
QC	quality control
RAES	radiological air emissions sampling
R&D	research and development
RMT	Radioactive Material Tracking system
RPL	Radiochemical Processing Laboratory
RTL	Research Technology Laboratory
scfm	standard cubic feet per minute
SOW	statement of work
TEDE	total effective dose equivalent
TT	non-condensable tritium with two H-3 isotopes
WAC	Washington Administrative Code
WDOH	Washington State Department of Health
σ_g	geometric standard deviation; a measure of particle size spread around the mean diameter for a log normal distribution
μ	micron

Contents

1.0 Introduction	1
1.1 Background Information.....	7
1.2 Compliance Requirements.....	10
2.0 Sampling System Design	12
2.1 Stack Velocity and Cyclonic Flow Measurements.....	13
2.2 Sampling Program	13
2.2.1 Schedule	13
2.2.2 Sample Flow Rate Systems	13
2.2.3 Sample Collection and Analysis by Sample Type	14
3.0 Procedures	15
4.0 Potential-to-Emit Dose and Principal Radionuclides.....	16
5.0 References	17
Appendix A Particulate Sample Analysis and Data Evaluation	A.1
Appendix B Tritium Sample Analysis and Data Evaluation	B.1
Appendix C Basis for Particle Line Loss Calculation	C.1
Appendix D PNNL Operated Stack Sampler Systems	D.1
Appendix E PNNL and PNNL-applicable Non-sampled (Stacks, Fugitive, and PIC-5) Emission Units	E.1
Appendix F Deregistered/Transitioned/Closed Emission Units	F.1

Figures

Figure D.1. 325-01-S Building Effluent Pathway	D.3
Figure D.2. 331-01-V Building Effluent Pathway.....	D.14
Figure D.3. 3410-01-S Effluent Pathway	D.19
Figure D.4. 3420-01-S Building Effluent Pathway	D.23
Figure D.5. 3430-01-S Building Effluent Pathway	D.27
Figure F.1. RTL-10-V Effluent Pathway.....	F.10
Figure F.2. RTL-11-V Effluent Pathway.....	F.14

Tables

Table 1.1. Summary of Active PNNL-Operated and -Applicable Emission Units and Compliance Methods.....	3
Table 1.2. Summary of Active PIC-5 Permits	4
Table 1.3. Summary of De-registered/Transitioned/Closed PNNL Managed Emission Units within the Last 5 Years	5
Table 1.4. Schedule for PNNL Major Emission Unit Routine Continuous Radionuclide Air Emission Sampling.....	6
Table 1.5. PNNL Radiological Air Emission Sampling Systems.....	7
Table 1.6. Summary of Radionuclide Emission Sampler Efficiencies (for 1- μ m particles with 2.25 σ_g)	8
Table 1.7. Verification of Absence of Cyclonic Flow Conditions in Stacks and Vents	9
Table 1.8. Facility NESHAP Compliance Summary for Sampled Emission Units.....	12
Table 3.1. Effluent Management Radiological Air Monitoring/Sampling Procedures.....	15
Table D.1. 325-01-S Building Exhaust Unit Flow Rate (from traverse data and as reported in the Hanford Site Annual Air Emissions Report)	D.4
Table D.2. 325-01-S Building Exhaust Unit Temperature (from traverse data)	D.4
Table D.3. 331-01-V Building Exhaust Unit Flow Rate (from traverse data and as reported in the Hanford Site Annual Report)	D.15
Table D.4. 331-01-V Building Exhaust Unit Temperature.....	D.15
Table D.5. 3410-01-S Building Exhaust Unit Flow Rate (from traverse data and as reported in the PNNL-Richland Campus Annual Report)	D.20
Table D.6. 3410-01-S Building Exhaust Unit Temperature (from traverse data)	D.20
Table D.7. 3420-01-S Building Exhaust Unit Flow Rate (from traverse data and as reported in the PNNL-Richland Campus Annual Report)	D.24
Table D.8. 3420-01-S Building Exhaust Unit Temperature (from traverse data)	D.24

Table D.9. 3430-01-S Building Exhaust Unit Flow Rate (from traverse data and as reported in the PNNL-Richland Campus Annual Report) D.28

Table D.10. 3430-01-S Building Exhaust Unit Temperature (from traverse data) D.28

Table F.1. RTL-10-V Exhaust Unit Flow Rate.....F.11

Table F.2. RTL-10-V Exhaust Unit Temperature.....F.11

Table F.3. RTL-11-V Exhaust Unit Flow Rate.....F.15

Table F.4. RTL-11-V Exhaust Unit Temperature.....F.15

1.0 Introduction

Battelle–Pacific Northwest Division is under contract to operate the Pacific Northwest National Laboratory (PNNL). PNNL conducts numerous research and development activities that have the potential to produce radionuclide air emissions. The U.S. Environmental Protection Agency (EPA) regulations in 40 Code of Federal Regulations (CFR) 61, “National Emission Standard for Hazardous Air Pollutants” (NESHAP), Subpart H (EPA 2002a) requires an assessment of all emission units that have the potential for radionuclide air emissions. Under NESHAP, “major” emission units are required to be sampled continuously, while “minor” emission units are not. Major and minor designations are determined using potential dose criteria specified in the regulations (see Acronyms, Abbreviations, and Terms). Washington Administrative Code (WAC) 246-247, *Radiation protection—air emissions* (WAC 2019), provides radioactive air emission licensing and regulation guidance for facilities that have the potential-to-emit (PTE) radionuclides. The potential for emissions from PNNL facilities is assessed annually to verify sampling requirements. The methodology used to evaluate the potential for emissions is documented in PNNL-10855, *Determining Unabated Airborne Radionuclide Emissions Monitoring Requirements Using Inventory-Based Methods* (Snyder, Daling, and Barnett 2021).

PNNL facilities are located at three U.S. Department of Energy (DOE) sites in Washington State: 1) the Hanford Site and 2) the PNNL-Richland Campus in Richland, and 3) the PNNL-Sequim Campus in Sequim.¹ Registered emission units are sorted in this document as sampled stack emission units, non-sampled emission units (including Hanford Site-wide units), and potential impact category (PIC)-5 permitted emission units. This arrangement sorts emission units from those with the most potential for offsite dose to those with the least.

To summarize the current PNNL-managed emission unit licenses and permits, several tables are provided:

- Table 1.1** lists emission units for PNNL’s Hanford Site activities and PNNL Richland and Sequim Campus operations
- Table 1.2** lists PIC-5 permits for PNNL Richland Campus site-wide application for specified activities
- Table 1.3** lists the systems that were transitioned or deregistered within the last 5 years
- Table 1.4** summarizes the type, frequency, and duration of sampling for continuously sampled units
- Table 1.5** summarizes system information for sampled emission units (details in appendices)

¹ The U.S. DOE PNNL Site is located at the PNNL-Richland Campus. The U.S. DOE Marine and Coastal Research Laboratory (MCRL) facility is located at the PNNL-Sequim Campus.

Topics covered in the remainder of this document are as follows:

- **Section 2** discusses sampling system design, including stack characteristics, sampling schedule, sampling flow rate, and sample collection and analysis topics.
- **Section 3** discusses key PNNL work processes that require procedures for radioactive air emission monitoring tasks and reviews done for sample system performance.
- **Section 4** briefly summarizes PTE dose and principal nuclides.

Appendix A summarizes the process for particulate samples analysis and data evaluation, and **Appendix B** reviews tritium sampling.

Appendix C covers particle deposition determinations in stacks.

Appendix D provides a compilation of currently active sampled emission unit details:

- a photograph of the stack and sample system
- emission sample unit ID
- traverse unit ID
- coordinate location of emission unit
- facility/process description
- emission unit specifics
- exhaust unit control technology
- exhaust unit flow rate
- record particulate sample system description
- sample extraction unit
- sample extraction probe
- sample transport line
- vacuum air sample system
- applicable drawings

Appendix E describes active PNNL and PNNL-applicable non-sampled emission units and PIC-5 permits. It includes Hanford Site 300 Area and Hanford Site-wide air permits applicable to PNNL.

Finally, **Appendix F** provides details on deregistered/transitioned emission units from the previous 5 years, and the time of emission unit status change.

Table 1.1. Summary of Active PNNL-Operated and -Applicable Emission Units and Compliance Methods

DOE Site for Emission Unit	Emission Type ^(a,b)	Emission Unit ID ^(c)	Building	Compliance Method
Hanford Site ^(d)	Point	EP-325-01-S	Radiochemical Processing Laboratory	Continuous sampling/monitoring ^(d)
	Point	EP-331-01-V	Life Sciences Laboratory I	Continuous sampling
	Point	EP-331-09-S	Life Sciences Laboratory I	Administrative controls and 40 CFR 61, Apdx D
	Fugitive	318 Building (J-318)	318 Building	Administrative controls and 40 CFR 61, Apdx D
	Fugitive	361 Building (J-361)	Modular Equipment Shelter	Administrative controls and 40 CFR 61, Apdx D
	Fugitive	300 Area Diffuse/Fugitive	300A/Excavation Activities (EU ID 443)	Site-wide ambient air monitoring program
	Fugitive	PTRAEU	Hanford Site ^(e) /PTRAEU (EU ID 447)	Administrative log
	Fugitive	Vented Containers	Hanford Site ^(e) /Vented Container Storage (EU ID 448)	Site-wide ambient air monitoring program and radiological surveys
	Fugitive	HEPA vacuums	Hanford Site ^(e) /HEPA vacuums (EU ID 455)	Administrative log
PNNL-Richland Campus ^(d)	Point	EP-3410-01-S	Materials Science and Technology	Continuous sampling
	Point	EP-3420-01-S	Radiation Detection Building – Filtered	Continuous sampling
	Point	EP-3420-02-S	Radiation Detection Building – Unfiltered	Administrative controls and 40 CFR 61, Apdx D
	Point	EP-3430-01-S	Ultratrace Analysis Building – Filtered	Continuous sampling
	Point	EP-3430-02-S	Ultratrace Analysis Building – Unfiltered	Administrative controls and 40 CFR 61, Apdx D
	Fugitive	J-3425	Ultra-Low Background Counting Laboratory	Administrative controls and 40 CFR 61, Apdx D
PNNL-Sequim Campus ^(f)	Point	N/A	N/A	N/A
	Fugitive	J-MSL	PNNL-Sequim Campus	Administrative controls and 40 CFR 61, Apdx D

- (a) “Fugitive emissions” are radioactive air emissions that do not and could not reasonably pass through a stack, vent, or other functionally equivalent structure, and that are not feasible to directly measure and quantify (WAC 246-247).
- (b) “Point source” is a discrete, well-defined location from which radioactive air emissions originate, such as a stack, vent, or other functionally equivalent structure (WAC 246-247).
- (c) Emission unit IDs in parentheses are PNNL Effluent Management IDs for the emission unit, where they differ from the license ID.
- (d) Continuous sampling and monitoring is required for PIC-1 stacks (Barnett 2018).
- (e) While the emission unit is permitted sitewide for the entire Hanford Site, PNNL applications are predominantly in the 300 Area, only.
- (f) Emission units are licensed under Hanford Site’s RAEL-FF-01; PNNL-Richland Campus’ RAEL-005; and PNNL-Sequim Campus’ RAEL-014.

Apdx D = Appendix D

PTRAEU = Portable/Temporary Radioactive Air Emission Unit

HEPA = high-efficiency particulate air (filter)

EU ID = emission unit identification (number) in Hanford Site’s RAEL-FF-01

Table 1.2. Summary of Active PIC-5 Permits

DOE Site	Emission Type^(a)	PIC-5 ID	PIC-5 Permit Name	Compliance Method
Hanford Site	PIC-5	N/A	N/A	N/A
PNNL-Richland Campus	PIC-5	J-VRRM	Richland Volumetrically-Released Radioactive Material	Administrative controls
	PIC-5	J-NDRM	Richland Non-dispersible Radioactive Material	Administrative controls
	PIC-5	J-Facilities Restoration	Richland Facilities Restoration on the PNNL Campus	Administrative controls
	PIC-5	J-SIOC	Richland Sources for Instrument/operational Checks ^(b)	Administrative controls
PNNL-Sequim Campus	PIC-5	N/A	N/A	N/A

(a) PIC-5: Potential Impact Category 5 permits are issued for a specific PNNL location to cover specific activities with a potential-to-emit dose of less than 1E-06 mrem (Barnett 2018).

(b) Also referred to as Low-level Sources (LLS) permit, J-LLS.

Table 1.3. Summary of De-registered/Transitioned/Closed PNNL Managed Emission Units within the Last 5 Years

DOE Site	Emission Unit	Emission Type ^(a,b)	Building	Previous Compliance Method	Status
Hanford Site	N/A	N/A	N/A	N/A	N/A
PNNL-Richland Campus	EP-3430-1606P-S	Point	Ultratrace Analysis Building – Perchloric Hood	Administrative review determined by 40 CFR 61, Apdx D	Closed in 2018
	EP-3430-1608P-S	Point	Ultratrace Analysis Building – Perchloric Hood	Administrative review determined by 40 CFR 61, Apdx D	Closed in 2018
	EP-3430-1610P-S	Point	Ultratrace Analysis Building – Perchloric Hood	Administrative review determined by 40 CFR 61, Apdx D	Closed in 2018
	EP-3430-1612P-S	Point	Ultratrace Analysis Building – Perchloric Hood	Administrative review determined by 40 CFR 61, Apdx D	Closed in 2018
	EP-3430-1614P-S	Point	Ultratrace Analysis Building – Perchloric Hood	Administrative review determined by 40 CFR 61, Apdx D	Closed in 2018
	EP-RTL-10-V	Point	Research Technology Laboratory	Periodic sampling – ANSI N13.1–1969 compliant sampling system	Transitioned in 2014/ Closed in 2019
	EP-RTL-11-V	Point	Research Technology Laboratory	Periodic sampling – ANSI N13.1–1969 compliant sampling system	Transitioned in 2014/ Closed in 2019
	J-RTL530	Fugitive	Research Technology Laboratory	Administrative review determined by 40 CFR 61, Apdx D	Closed in 2019
	J-RTL-Complex	Fugitive	Research Technology Laboratory Complex	Administrative review determined by 40 CFR 61, Apdx D	Closed in 2019
	EP-LSLII-01-V	Point	Life Sciences Laboratory II	Administrative review determined by 40 CFR 61, Apdx D	Transitioned in 2012/ Closed in 2019
EP-LSLII-02-V	Point	Life Sciences Laboratory II	Administrative review determined by 40 CFR 61, Apdx D	Transitioned in 2012/ Closed in 2019	
PNNL-Sequim Campus	MSL-1	Fugitive	MSL-1	Administrative review determined by 40 CFR 61, Apdx D	Transitioned in 2018
	MSL-5	Fugitive	MSL-5	Administrative review determined by 40 CFR 61, Apdx D	Transitioned in 2018

(a) “Fugitive emissions” are radioactive air emissions that do not and could not reasonably pass through a stack, vent, or other functionally equivalent structure, and that are not feasible to directly measure and quantify (WAC 246-247).

(b) “Point source” is a discrete, well-defined location from which radioactive air emissions originate, such as a stack, vent, or other functionally equivalent structure (WAC 246-247).

Table 1.4. Schedule for PNNL Major Emission Unit Routine Continuous Radionuclide Air Emission Sampling

Emission Point	PNNL PIC	Sampling Frequency	Sample Type	Sample Period	Constituents Analyzed	Sample Media or Tracking Method	Comments
Hanford Site/300 Area Active Emission Units							
EP-325-01-S	1	Continuous	Particulate	2 weeks	Alpha/Beta	Filter	Major emission unit—ANSI/HPS N13.1–2011; isotopic analysis on composites; radon is tracked rather than sampled (also see Appendix A)
			Water Vapor	1 month	Tritium	Silica Gel	
			Gas	1 month	Tritium	Silica Gel	
			Gas	Tracking	Radon	RMT Tracking	
			Composite	6 months	Specific Nuclides	Composited Filters	
Monitoring	1 month	CAM Alpha/Beta-gamma ^(a)	Filter				
EP-331-01-V	2	Continuous	Particulate	2 weeks	Alpha/Beta	Filter	Major emission unit—ANSI N13.1–1969; isotopic analysis on composites (see Appendix A)
			Composite	6 months	Specific Nuclides	Composited Filters	
PNNL-Richland Campus Active Emission Units							
EP-3410-01-S	2	Continuous	Particulate	2 weeks	Alpha/Beta	Filter	Major emission unit—ANSI/HPS N13.1–2011; isotopic analysis on composites (see Appendix A)
			Composite	6 months	Specific Nuclides	Composited Filters	
EP-3420-01-S	2	Continuous	Particulate	2 weeks	Alpha/Beta	Filter	Major emission unit—ANSI/HPS N13.1–2011; isotopic analysis on composites (see Appendix A)
			Composite	6 months	Specific Nuclides	Composited Filters	
EP-3430-01-S	2	Continuous	Particulate	2 weeks	Alpha/Beta	Filter	Major emission unit—ANSI/HPS N13.1–2011; isotopic analysis on composites (see Appendix A)
			Composite	6 months	Specific Nuclides	Composited Filters	isotopic analysis on composites (see Appendix A)

CAM = continuous air monitor; RMT = Radioactive Material Tracking System

Alpha/Beta = gross alpha and gross beta

(a) The CAM measures gross alpha and gross beta/gamma activity as it is collected on the filter. Used CAM filters are stored by the analytical laboratory and may be analyzed if deemed necessary.

Table 1.5. PNNL Radiological Air Emission Sampling Systems

Emission Unit Number	Building (Number)	Unit Description	Release Height Above Grade (ft)	Effective Release Height (ft) ^(a)	Average Flow Rate (ft ³ /min) ^(b)	Average Temperature (°F) ^(b)
Hanford Site/300 Area Active Emission Units						
EP-325-01-S ^(c)	Radiochemical Processing Laboratory (325)	Stack	88.8	269	141,600	77
EP-331-01-V	Life Sciences Laboratory (331)	Vent	62.0	163	62,600	73
PNNL-Richland Campus Active Emission Units						
EP-3410-01-S	Materials Science and Technology Laboratory (3410)	Stack	44.4	105	22,200	75
EP-3420-01-S	Radiation Detection Laboratory (3420)	Stack	50.9	138	55,700 ^(d)	74
EP-3430-01-S	Ultratrace Laboratory (3430)	Stack	44.4	117	35,500	71

- (a) The effective release height is equal to the physical stack height plus the plume rise attributable to momentum and buoyancy. Effective release height (procedure [EPRP-AIR-013](#)) for each emission unit is calculated using the data reported in this document.
- (b) Average flow rate and temperature are determined from traverse results for the 2016-2020 sample periods.
- (c) The EP-325-01-S emission unit includes a CAM and record particulate sampling system.
- (d) An additional fan was added to EP-3420-01-S in October 2020, increasing the average flow rate to about 68,000 cfm.
- Conversions: 1 foot (ft) = 0.3048 meter (m); 1 ft³/min = 0.0283 m³/min.

1.1 Background Information

In response to EPA plans to revise the emission sampling regulations, PNNL initiated a comprehensive effort to upgrade facility radionuclide emission sampling systems in 1990. The EPA regulations were issued on December 15, 1989, as 40 CFR 61, Subpart H “National Emission Standard for Emissions of Radionuclides Other Than Radon from Department of Energy Facilities” (EPA 2002a).

Prior to 2002, PNNL sampling systems were designed to be operated at a nominal sample rate of 2 cubic feet per minute (cfm); that is, the sample probe nozzles were sized to operate isokinetically at a sample rate of 2 cfm. Accurate setting of sample rates to achieve isokinetic sampling conditions requires that the exhaust system velocity be measured at the sample extraction location. However, changes in facility ventilation flow rates, degradation of the sampler vacuum supply, or compliance with the American National Standards Institute/Health Physics Society (ANSI/HPS) N13.1–2011 (HPS 2011) can result in deviation from the original isokinetic design.¹

¹ ANSI/HPS N13.1 was reissued in 2011 and was unchanged from the 1999 version. While different from the 1999 nomenclature in 40 CFR 61, Subpart H, the 2011 re-affirmation nomenclature has been adopted herein.

ANSI/HPS N13.1–2021 (HPS 2021) was finalized recently. While a gap analysis for the PNNL ANSI/HPS N13.1–2011-compliant stacks has yet to be completed, it is expected that they will be found ANSI/HPS N13.1–2021 compliant, as well. A notable update in the 2021 standard is the addition of optimizing a sampling location using computational fluid dynamics (CFD) modeling.

Information obtained during sampler inspections and stack velocity measurements was used with the Deposition computer software code (DEPO; McFarland et al. 2000) to estimate the deposition of particles collected in each sampling system. Since 1990, the sampling systems have been periodically evaluated for sampling error caused by sampling system line losses using DEPO or Deposition Calculator (see Appendix C). Penetration efficiencies are re-evaluated when stack modifications would impact the current determination. The 3420 stack was remodeled in 2020 to add an additional fan and air blender. Table 1.6 summarizes the most current data.

Table 1.6. Summary of Radionuclide Emission Sampler Efficiencies (for 1- μm particles with $2.25 \sigma_g$)

Emission Unit	Emission Sample Unit Number	No. of Nozzles	Flow Range (cfm)		Penetration Efficiency Range ^(a) (%)
			Stack Flow Rate	Sampler Flow Rate	
Hanford Site/300 Area Active Emission Units					
EP-325-01-S	ESP-325-01-S (CAM)	6	50,000 to 180,000	5-30	97 to 99
EP-325-01-S	ESP-325-01-S	1	50,000 to 180,000	1-5	96 to 99
EP-331-01-V	ESP-331-01-D	6	35,000 to 75,000	1-5	96 to 103
PNNL Campus Active Emission Units					
EP-3410-01-S	ESP-3410-01-S	1	10,000 to 30,000	1-5	96 to 99
EP-3420-01-S	ESP-3420-01-S	1	16,500 to 100,000	1-5	88 to 99
EP-3430-01-S	ESP-3430-01-S	1	20,000 to 35,000	1-5	96 to 99

(a) Sampler transport efficiencies were calculated for the particulate samplers with varying stack and sampler flow rates. The emission sample unit transport efficiencies assumed a particle size of 1 μm with $\sigma_g = 2.25$. See project records (EM Rad Air File Plan) for detailed line loss calculations, stack qualification tests, and building fan drawings.

In addition, major emission unit cyclonic flow measurements are conducted for each sampling system when each system is brought online and when configurations change, according to 40 CFR 60, Appendix A-1 to Part 60, Method 1, Section 11.4, “Verification of Absence of Cyclonic Flow” (EPA 2014). Table 1.7 summarizes the current results of these measurements.

Table 1.7. Verification of Absence of Cyclonic Flow Conditions in Stacks and Vents

Emission Unit Number	Unit Name	Traverse Point	Date	Average Yaw Angle (degrees)	Acceptable (Yes/No) ^(a)
Hanford Site/300 Area Active Emission Units					
EP-325-01-S	Radiochemical Processing Laboratory	TP-325-01-1	05/01/2011	≤14.3 ^(b)	Yes
EP-331-01-V	Life Sciences Laboratory	TP-331-01-1	08/02/2000	10.7	Yes
PNNL-Richland Campus Active Emission Units					
EP-3410-01-S	Materials Science and Technology Laboratory	TP-3410-01-1	04/03/2013	4.0	Yes
EP-3420-01-S	Radiation Detection Laboratory	TP-3420-01-1	10/27/2020	≤15.5 ^(b)	Yes
EP-3430-01-S	Ultratrace Laboratory	TP-3430-01-1	07/12/2010	2.6	Yes

(a) If the average Yaw angle is > 20 degrees, then the overall flow condition in the stack is unacceptable. If the average Yaw angle is ≤ 20 degrees, then the flow condition in the stack is acceptable.

(b) The angle varied depending on which fan configuration was operational.

In 2002, the EPA amended 40 CFR 61 Subpart H (EPA 2002a) and 40 CFR 61 Appendix B Method 114 (EPA 2002b) to include requirements from ANSI/HPS N13.1–2011 (HPS 2011) for new or modified emission units. Additionally, the Washington State Department of Health (WDOH) amended WAC 246-247 (WAC 2019) to include ANSI/HPS N13.1–2011 (HPS 2011) requirements in 2005. A result of the amended regulations is the requirement to prepare a written technical basis for the radiological air emission sampling and monitoring program. The technical basis must address the sampling objective, graded approach for meeting the objectives, relevant building operating conditions and airborne contaminants, and action levels that signal changing conditions of significance.

A key component of the technical basis is the PIC assigned to an emission unit. ANSI/HPS N13.1–2011 uses PICs to define a graded approach to sampling for airborne radioactive materials. The PICs used for illustrative purposes in the standard are based on potential “dose consequences that may occur assuming effluent attenuation or filtration devices present in the effluent stream have no effect” (HPS 2011). This is comparable to the definition for PTE used in radiological air emission regulations.

PNNL has adopted the suggested PIC definitions provided in ANSI/HPS N13.1–2011 (HPS 2011), as applied to the federal and state standards of 10 mrem/year. Following the graded approach advocated in ANSI/HPS N13.1–2011, PNNL has defined an additional PIC-5 category with PTE criteria orders of magnitude below that of PIC-4 to allow for appropriate and efficient permitting and management of radioactive materials with inconsequential contributions to potential off-site dose. Although PTEs for each emission unit are calculated annually using actual inventory, the PTE used for assigning PICs is the permitted PTE stated in the license, which is based on maximum estimated inventory and throughput for permitted activities. Continuous radionuclide sampling is conducted on all emission units designated as “major.” The criteria found in *Pacific Northwest National Laboratory Potential Impact Categories for*

Radiological Air Emission Monitoring (Barnett 2018) is considered when setting sampling requirements. See Barnett 2018 for further details regarding the PNNL-defined PIC categories.

In 2007, PNNL began construction on the Physical Sciences Facility (PSF), which is a complex of five research laboratories: 3410 – Materials Science and Technology, 3420 – Radiation Detection, 3425 – Ultra-Low Background Counting, 3430 – Ultratrace, and 3440 – Large Detector. Of these five laboratories, only the 3410, 3420, and 3430 buildings house processes that use dispersible radioactive materials in quantities sufficient to require continuous sampling. Emission units at PSF facilities became operational in 2010.

1.2 Compliance Requirements

The primary drivers for the airborne radionuclide emission sampling and monitoring program are as follows:

- 40 CFR 61, Subpart H, “National Emission Standards for Emissions of Radionuclides other than Radon from Department of Energy Facilities” (EPA 2002a), applies to DOE-owned or operated facilities that emit radionuclides other than Rn-222 and Rn-220 to the air and require 1) evaluating potential radiological air emission sources for impact to the public and environment, 2) sampling air effluent streams, 3) registering certain sources and emissions, 4) filing notices of construction for new and or modified sources, 5) complying with the 10-millirem (mrem) dose standard, 6) evaluating best available control technology, 7) reporting emissions, and 8) maintaining a quality assurance program.
- WAC 246-247, *Radiation Protection—Air Emissions* (WAC 2019), provides licensing requirements for 1) monitoring facility radioactive air emissions, 2) evaluating potential radiological air emission sources for impact to the public and environment, 3) sampling air effluent streams, 4) filing notices of construction for new and or modified sources, 5) complying with the 10-mrem dose standard, 6) evaluating best available control technology, 7) reporting emissions, and 8) maintaining a quality assurance program.
- 40 CFR 70, *State Operating Permit Programs* (EPA 2020), provides for maintaining state air operating permit programs, demonstrating emission levels, and complying with permit conditions as applicable.
- WAC 173-401, *Operating Permit Regulation* (WAC 2018), requires applying for an air operating permit, demonstrating emission levels, and complying with permit conditions as applicable.
- WAC 173-480, *Ambient Air Quality Standards and Emission Limits for Radionuclides* (WAC 2007), defines maximum allowable levels for radionuclides in ambient air and control emissions from specific sources

- DOE Order 436.1, *Departmental Sustainability* (DOE 2011), requires DOE sites to implement an Environmental Management System (EMS) as part of a Site Sustainability Plan. An EMS enables an organization to identify and control the environmental impact of its activities, products, or services; continually improve its environmental performance; and implement a systematic approach to setting environmental objectives and targets.
- DOE Order 458.1 *Radiation Protection of the Public and the Environment* (DOE 2020), established requirements to protect the public and the environment against undue risk from radiation. Major portions of this order are not in the PNNL contract.
- DOE-HDBK-1216-2015, *Environmental Radiological Effluent Monitoring and Environmental Surveillance* (DOE 2015), identifies procedures, systems, methods, instruments, and practices for radiological effluent monitoring.

Facility airborne radionuclide emission sampling requirements are derived from 40 CFR 61, Subpart H (EPA 2002a), and WAC 246-247 (WAC 2019). The regulations require:

- Continuous sampling at airborne emission units for which annual emissions could result in a potential effective dose equivalent (EDE) to an off-site individual of 0.1 mrem/yr or more.
- When continuous sampling is required, all radionuclides that contribute greater than 10% of the PTE total effective dose equivalent (TEDE) to the maximally exposed individual (MEI), greater than 0.1 mrem/yr PTE TEDE to the MEI, and greater than 25% of the TEDE to the MEI after controls for a release point shall be measured.
- Any identified radioisotope with the PTE to meet the requirements of the bullets above shall be reported and, if not measured analytically, evaluated using 40 CFR 61, Appendix D (EPA 1989), as clarified by WDOH.

Washington State regulations primarily reflect federal regulations but are also allowed to be more stringent than federal regulations. EPA granted partial approval to WDOH's request for program approval and delegation of authority to implement and enforce the Radionuclide NESHAP program in 71 FR 32276–32282 (EPA 2006).

The potential EDE to an off-site individual is based on a projection of the emissions that could result during normal operations and anticipated process upsets, assuming all pollution control equipment (e.g., HEPA filters) did not exist. For EPA regulations, the MEI is a member of the public at any off-site point where there is a residence, school, business, or office. For the Washington State regulations, the MEI is any member of the public who abides or resides in an unrestricted area. The methodology used to evaluate the potential for emissions is documented in *Determining Unabated Airborne Radionuclide Emissions Monitoring Requirements Using Inventory-Based Methods* (Snyder, Daling, and Barnett 2021). Table 1.8 shows the results for the sampled emission units.

Table 1.8. Facility NESHAP Compliance Summary for Sampled Emission Units

Emission Unit Number	Building	Permit or License Potential Off-site Dose (mrem/yr)	Radionuclides Requiring Annual Reporting (2020) ^(a)	Continuous Sampling Required
Hanford Site/300 Area Active Emission Units				
EP-325-01-S	325	4.1E+02	Ac-227, Am-241, Am-243, Cm-244, Co-60, Cs-137, Eu-152, Eu-154, Gd-153, H-3, Pu-238, Pu-239, Pu-240, Pu-241, Ra-226, Rn-219, Rn-220, Rn-222, Ru-106, Sr-90 Tc-99, U-232, U-233	Yes
EP-331-01-V	331	3.86E+00	Am-241, Am-243, Co-60, Cs-137, Np-237, Pu-238, Pu-239, Pu-240	Yes
PNNL Campus Active Emission Units				
EP-3410-01-S	3410	3.66E+00	Am-241, Am-243, Cm-244, Co-60, Cs-137, I-125, Pu-238, Pu-239, Pu-240, Sr-90, U-233	Yes
EP-3420-01-S	3420	3.70E+00	Al-26, Am-241, Am-243, Cm-244, Co-60, Cs-137, Pu-238, Pu-239, Pu-240	Yes
EP-3430-01-S	3430	4.20E+00	Am-241, Am-243, Cm-244, Co-60, Cs-137, Pu-238, Pu-239, Pu-240, U-233	Yes

(a) Based on annual radioactive air emissions site reports for 2020 and when stack license conditions indicate a specific emission limit for the nuclide. Gross alpha and gross beta results are also reported.

2.0 Sampling System Design

Both federal and state regulations incorporate ANSI/HPS N13.1 for sampling system design requirements.

- Prior to September 2002, the 1969 method (ANSI 1970) was utilized;
- After September 2002, federal regulations adopted ANSI/HPS N13.1–1999 (HPS 1999) for new or modified systems (reissued essentially unchanged in 2011 as referenced throughout this document [HPS 2011]).¹

Data on sampler design characteristics were obtained from facility safety analysis reports, engineering drawings, vendor design documents, and system inspections. Since 1991, PNNL’s Effluent Management (EM) group has been involved with the facility modification process to verify that systems are designed and installed as required and that design drawings are maintained.

Details regarding each specific sampling system for PNNL-operated emission units on the Hanford Site are provided in Appendix D, Section D.1. Similar details for emission units on the PNNL-Richland Campus are provided in Appendix D, Section D.2. There are no sampling systems for emission units at the PNNL-Sequim Campus.

¹ See Section 1.1 for discussion of recently finalized ANSI/HPS N13.1–2021.

2.1 Stack Velocity and Cyclonic Flow Measurements

The stack velocity and cyclonic flow conditions at the sample extraction point are measured according to 40 CFR 60, Appendix A-1, Method 2 (EPA 2014). PNNL Facilities & Operations (F&O) staff performs these measurements in support of the effluent monitoring task.

The following PNNL procedures were derived from the regulatory guides and are used by the F&O Air Balance staff:

- [EPRP-AIR-016](#), *PNNL Stack/Duct Velocity Traverse Method*
- [EPRP-AIR-017](#), *Verification of Absence of Cyclonic Flow Conditions in Stacks and Vents*
- [EPRP-AIR-019](#), *Standard and Type S Pitot Tube Specifications Inspection Procedure*

2.2 Sampling Program

2.2.1 Schedule

A sampling program may include any of the following sampling schedules:

- Continuous particulate sampling – The sampler is operated continuously throughout the year, and the sample is exchanged approximately every 2 weeks.
- Continuous tritium sampling – The sampler is operated continuously throughout the year, and the sample is exchanged approximately every month.
- Quarterly sampling – A single sample is collected every quarter for a 2-week period.
- Annual sampling – A single sample is collected once a year for a 2-week period.
- Special sampling – A sample is collected as needed to follow up on sampler problems or investigate anomalies in sample results.
- Other sampling – A sample may be collected from system cleaning or other activity or study. Surveys are included in this category.

The basic sampling frequency for each PNNL emission unit sampled continuously is summarized in Table 1.4. Any emission units requiring periodic sampling would be indicated in Table 1.1; there are currently no systems that require routine periodic sampling.

2.2.2 Sample Flow Rate Systems

Stack sample flow rate systems follow guidance provided in Standard N13.1. Depending on the year the system was put into service or modified, ANSI N13.1–1969 (ANSI 1970) or ANSI/HPS N13.1–2011 (HPS 2011) is utilized. Table 1.4 identifies the version of the N13.1 standard to which each emission unit is designed and operated. Additional information is provided below and in the appendixes for specific emission units.

- For ANSI N13.1–1969 systems, PNNL measures the sample flow rate by a Brooks Instrument GT-1000 (0.586 to 5.86 standard cubic feet per minute [scfm]) rotameter (Brooks Instrument, 407 West Vine Street, Hatfield, PA 19440) and adjusted using a throttle valve (both located just downstream of the filter holder). A vacuum gauge (0 to 100 in. of water) is installed on the inlet side of the rotameter and used to correct the sample flow for vacuum conditions. Sampler flows are set at or near isokinetic based on stack flow measurements that are performed on an annual basis. The rotameter and vacuum gauge are calibrated and exchanged annually.
- For ANSI/HPS N13.1–2011 systems, PNNL measures the sample flow rate by using a MASS-tron (1.0 to 4.0 scfm) flow transmitter (Air Monitor, 1050 Hopper Ave., Santa Rosa, CA 95403). The radiological air emissions sampling (RAES) system measures both the total stack exhaust mass flow rate and a representative variable sample mass flow rate with the sample flow being extracted from the building exhaust air stack. The sample flow rate is maintained proportionally to the stack air flow rate and operates over the calibrated range of air velocities and temperatures with a minimum turndown ratio of 10:1. The RAES system interfaces with the vacuum air sampling system that draws the stack air samples through an extraction nozzle located on the sample probe.

2.2.3 Sample Collection and Analysis by Sample Type

2.2.3.1 Particulate Sample Collection and Analysis

Particulate record samples are collected using a 47-mm Versapor 3000[®], an acrylic copolymer membrane filter on a nylon substrate (Pall Gelman Versapor[®] Membranes, Krackeler Scientific, Inc., 57 Broadway, Albany, NY 12202) supported by a filter holder. Filters are manufactured in pore sizes ranging from 0.2 to 3 μm with diameters ranging from 25 to 293 mm. The membrane filter has an estimated retention efficiency of greater than 99% for 0.3- μm particles (Pall Corporation 2000). For uses in air filtration, typical flow rates range from 1.8 to 52 $\text{L min}^{-1} \text{cm}^{-2}$. The typical filter thickness is 190 μm (Barnett et al. 2009).

Two-week particulate record samples are collected for some emission units (see Table 1.4). During sampling events, sample systems are inspected daily for proper flow-rate settings and system operation, excluding weekends and holidays. Sample systems are enclosed in metal cabinets for protection from inclement weather. See Appendix A for additional information regarding sample analysis and data evaluation.

2.2.3.2 Vapor and Gas Sample Collection and Analysis

At this time, tritium is the only vapor sample collected and is specific to the 325 Building main stack. Tritium sample collection details are provided in the 325-01-S sampling system description. See Appendix B for tritium sample analysis and data evaluation requirements. Where allowed by permit, PNNL tracks gas emissions such as radon (at the 325 Building) rather

than sampling. Quantities released are tracked via the Radioactive Air Gas Emissions database (<http://ragas.pnl.gov/>).

3.0 Procedures

PNNL’s EM group maintains documented technical and operating procedures for all aspects of effluent monitoring. The PNNL standards-based management system How Do I? (HDI) workflow “Create or Update Procedures and Other Work Instructions” (PNNL 2021) contains the requirements for preparation, review, and approval of these procedures. EM procedures incorporate all required elements of the aforementioned subject area.

EM procedures follow the requirements and format of Environmental Protection and Regulatory Programs (EPRP) Department procedure [EPRP-ADMIN-003](#), *EPRP Work Instruction*. Key work processes requiring procedures to conduct radioactive air emission monitoring tasks include the following:

- prepare notice of construction (NOC) applications
- measure facility exhaust flow rates and conditions
- determine sample system collection efficiencies
- collect samples
- operate the 325 Building CAM
- respond to unplanned/unexpected emission measurements
- inspect emission unit sample lines and instrumentation.

Table 3.1 identifies the EM procedures used in sampling and monitoring PNNL radiological emission units.

Table 3.1. Effluent Management Radiological Air Monitoring/Sampling Procedures

Procedure Number ^(a)	Procedure Title
EPRP-AIR-004	Chain of Custody Procedure
EPRP-AIR-005	Troubleshooting and Repair of Stack Emission Sampling/Monitoring Systems
EPRP-AIR-010	Stack Particulate Sampling Procedure
EPRP-AIR-011	325 Building Stack Tritium Sampling Procedure
EPRP-AIR-013	Preparing Notice of Construction Applications for Radioactive Air Emissions
EPRP-AIR-014	Line Loss Calculations for Radiological Air Emissions Monitoring
EPRP-AIR-015	Evaluating Rad Air Effluent Sampling Data
EPRP-AIR-016	PNNL Stack/Duct Velocity Traverse Method
EPRP-AIR-017	Verification of Absence of Cyclonic Flow Conditions in Stacks and Vents
EPRP-AIR-019	Standard and Type S Pitot Tube Specifications Inspection
EPRP-AIR-020	Videoscope Inspection and Assessment of Stack Sample Lines

Procedure Number^(a)	Procedure Title
EPRP-AIR-021	Source Response and Calibration Test on the PNNL OS3300 Stack Air Particulate Radionuclide Monitoring System at the 325 Building Main Stack
EPRP-AIR-022	Source Response and Calibration Test on the PNNL OS3700 Tritium Monitoring System for the 325 Building Main Stack
EPRP-AIR-023	325 Building Stack Radionuclide Sampling and Monitoring Systems Daily Inspection
EPRP-AIR-024	325 Stack PNNL OS3700 Tritium CAM Alarm Test Procedure
EPRP-AIR-025	RPL Stack PNNL OS3300 Alpha/Beta CAM Filter Exchange
EPRP-AIR-026	Operation of the PNNL OS3300 Stack Particulate Monitoring System at the 325 Building Main Stack
EPRP-AIR-027	Operation of the PNNL OS3700 Tritium Emission Monitoring System at the 325 Building Main Stack
EPRP-AIR-028	PSF Radioactive Air Emissions Sampling (RAES) Systems Filter Exchange and Inspection
EPRP-AIR-030	Rotameters/Vacuum Gauges Annual Calibration
EPRP-AIR-031	331 Building Stack Sample Probe Removal, Cleaning, Inspection, and Reinstallation

(a) The procedures listed above can be accessed at https://eprp.pnl.gov/documents.aspx?topic=Procedures_and_Documentation#AIR. The access date for the procedure list was November 2021.

4.0 Potential-to-Emit Dose and Principal Radionuclides

The potential EDE to an individual is an inventory-based projection of the emissions that could result during normal operations, assuming the emissions are not reduced by installed emission abatement control equipment. The assessment considers all pathways (inhalation, food ingestion, and external dose from air and soil surface) and assumes 24/7 occupancy by the receptor.

The PTE dose calculation for each DOE site uses pre-calculated dose factors based on site-specific release and receptor locations and applicable meteorological data. These are based on a standardized approach for each site and allow a variety of staff to determine the PTE dose.

- Hanford Site: use Snyder and Rokkan 2016 dose factors
- PNNL-Richland Campus: use Snyder and Barnett 2016 dose factors, and
- PNNL-Sequim Campus: use dose factors in appendix of recent NESHAP compliance report.

A radionuclide inventory assessment is performed on an annual basis to determine facility PTE (in mrem/yr). This assessment is used to verify compliance with the EPA and WDOH permits and to determine the need for continuous compliance sampling (40 CFR 61, Subpart H; EPA 2002a). The results of past and current annual NESHAP assessments are available from the task lead. The nuclide-specific analyses for composite samples are established from the NESHAP assessments and permit requirements.

PTE doses are estimated and documented in site licenses for WDOH compliance determination. PTE doses are also reviewed annually to confirm the PTE dose estimate continues to be less than

the license value. Operations adjustments can be made if the proposed annual PTE confirmation result is above the license value as managed by Radioactive Materials Tracking.

5.0 References

ANSI – American National Standards Institute. 1970. *Guide to Sampling Airborne Radioactive Materials in Nuclear Facilities*. ANSI N13.1–1969. Washington, DC.

Barfuss BC. 2007. *Development of a Tritium Dilution Factor from Measured Laboratory Emissions and Localized Ambient Air Sampling Measurements*. Washington State University, Pullman, WA.

Barnett JM, LA True, and DD Douglas. 2004. “Review of Tritium Emissions Sampling and Monitoring from the Hanford Site Radiochemical Processing Laboratory.” In: *Proceedings of the HPS 2004 Midyear Meeting – Air Monitoring and Internal Dosimetry*, February 8-11, 2004, Augusta, GA. McLean, VA: Health Physics Society; 199-204.

Barnett JM. 2018. *Pacific Northwest National Laboratory Potential Impact Categories for Radiological Air Emission Monitoring*. PNNL-19904, Rev. 5. Pacific Northwest National Laboratory, Richland, WA. <https://doi.org/10.2172/1526748>

Barnett JM, VI Cullinan, DS Barnett, TLT Trang-Le, M Bliss, LR Greenwood, and MY Ballinger. 2009. “Results of a Self-Absorption Study on the Versapor 3000 47-mm Filters for Radioactive Particulate Air Stack Sampling.” *Health Physics* 97:161–168.

Barnett JM and SF Snyder. 2018. *Pacific Northwest National Laboratory Facility Radionuclide Emission Points and Sampling Systems*. PNNL-15992, Rev. 4. Pacific Northwest National Laboratory, Richland, WA.

Blunt BC. 2015. *Deposition Calculator Technical Description Manual*. BC-15-RP-003, Rev. 0. Blunt Consulting, LLC., Williston, SC.

Blunt BC. 2016. *Deposition Calculator User’s Manual*. BC-15-RP-002, Rev. 0. Blunt Consulting, LLC., Williston, SC.

DOE – U.S. Department of Energy. 2011. “Departmental Sustainability.” DOE Order 436.1. Washington, DC.

DOE – U.S. Department of Energy. 2020. “Radiation Protection of the Public and the Environment.” DOE Order 458.1, Chg 4. Washington, DC.

DOE – U.S. Department of Energy. 2015. “Environmental Radiological Effluent Monitoring and Environmental Surveillance.” DOE-HDBK-1216-2015. Washington, DC.

Dyckman DL, JE Cranna, and SF Snyder. 2021. *Radionuclide Air Emissions Report for the*

Hanford Site, Calendar Year 2020. DOE/RL-2021-12. U.S. Department of Energy, Richland Operations Office, Richland, WA.

EPA – U.S. Environmental Protection Agency. 1989. “Methods for Estimating Radionuclide Emissions.” *U.S. Code of Federal Regulations*.” 40 CFR 61, Appendix D. U.S. Government Printing Office, Washington, DC.

EPA – U.S. Environmental Protection Agency. 2002a. “National Emission Standards for Emissions of Radionuclides Other Than Radon from Department of Energy Facilities.” 40 CFR 61, Subpart H. Government Printing Office, Washington, DC.

EPA – U.S. Environmental Protection Agency. 2002b. “Test Methods for Measuring Radionuclide Emissions from Stationary Sources.” 40 CFR 61, Appendix B, Method 114. Government Printing Office, Washington, DC.

EPA – U.S. Environmental Protection Agency. 2006. “Partial Approval of the Clean Air Act, Section 112(l), Delegation of Authority to the Washington State Department of Health.” 71 FR 32276–32282. June 5. Government Printing Office, Washington, DC.

EPA – U.S. Environmental Protection Agency. 2014. “Standards of Performance for New Stationary Sources, Appendix A-1: Test Methods.” 40 CFR 60, Appendix A-1, Methods 1, 1a, and 2. U.S. Government Printing Office, Washington, DC.

EPA – U.S. Environmental Protection Agency. 2020. “State Operating Permit Programs.” 40 CFR 70. Government Printing Office, Washington, DC.

[EPRP-ADMIN-003](#), *EPRP Work Instruction*. Current at publication: Rev. 11, December 2021.

[EPRP-AIR-004](#), *Chain of Custody Procedure*. Current at publication: Rev. 10, June 2021.

[EPRP-AIR-005](#), *Troubleshooting and Repair of Stack Emission Sampling/Monitoring Systems*. Current at publication: Rev. 6, December 2018.

[EPRP-AIR-010](#), *Stack Particulate Sampling Procedure*. Current at publication: Rev. 13, February 2020.

[EPRP-AIR-011](#), *325 Building Stack Tritium Sampling Procedure*. Current at publication: Rev. 10, October 2018.

[EPRP-AIR-013](#), *Preparing Notice of Construction Applications for Radioactive Air Emissions*. Current at publication: Rev. 10, November 2017.

[EPRP-AIR-014](#), *Line Loss Calculations for Radiological Air Emissions Monitoring*. Current at publication: Rev. 8, April 2020.

[EPRP-AIR-015](#), *Evaluating Rad Air Effluent Sampling Data*. Current at publication: Rev. 8,

October 2019.

[EPRP-AIR-016](#), *PNNL Stack/Duct Velocity Traverse Method*. Current at publication: Rev. 7, September 2018.

[EPRP-AIR-017](#), *Verification of Absence of Cyclonic Flow Conditions in Stacks and Vents*. Current at publication: Rev. 7, July 2020.

[EPRP-AIR-019](#), *Standard and Type S Pitot Tube Specifications Inspection*. Current at publication: Rev. 7, December 2018.

[EPRP-AIR-020](#), *Videoscope Inspection and Assessment of Stack Sample Lines*. Current at publication: Rev. 6, March 2020.

[EPRP-AIR-021](#), *Source Response and Calibration Test on the PNNL OS3300 Stack Air Particulate Radionuclide Monitoring System at the 325 Building Main Stack*. Current at publication: Rev. 6.01, October 2020.

[EPRP-AIR-022](#), *Source Response and Calibration Test on the PNNL OS3700 Tritium Monitoring System for the 325 Building Main Stack*. Current at publication: Rev. 5.01, September 2019.

[EPRP-AIR-023](#), *325 Building Stack Radionuclide Sampling and Monitoring Systems Daily Inspection*. Current at publication: Rev. 6, November 2020.

[EPRP-AIR-024](#), *325 Stack PNNL OS3700 Tritium CAM Alarm Test Procedure*. Current at publication: Rev. 6, July 2021.

[EPRP-AIR-025](#), *RPL Stack PNNL OS3300 Alpha/Beta CAM Filter Exchange*. Current at publication: Rev. 6, August 2021.

[EPRP-AIR-026](#), *Operation of the PNNL OS3300 Stack Particulate Monitoring System at the 325 Building Main Stack*. Current at publication: Rev. 6, February 2021.

[EPRP-AIR-027](#), *Operation of the PNNL OS3700 Tritium Emission Monitoring System at the 325 Building Main Stack*. Current at publication: Rev. 6, February 2021.

[EPRP-AIR-028](#), *PSF Radioactive Air Emissions Sampling (RAES) Systems Filter Exchange and Inspection*. Current at publication: Rev. 4, June 2021.

[EPRP-AIR-030](#), *Rotameters/Vacuum Gauges Annual Calibration*. Current at publication: Rev. 2, October 2021.

[EPRP-AIR-031](#), *331 Building Stack Sample Probe Removal, Cleaning, Inspection, and Reinstallation*. Current at publication: Rev. 2, February 2021.

Glissmeyer JA. 1991. “Recommendation of Particle Line-Loss Code.” Letter to MJ Sula. Pacific Northwest National Laboratory, Richland, WA.

Haglund JS, B Humphrey, and S Chandler. 2010. *Deposition 5.0 User’s Manual*. DEPO 5.0, Applied Research Laboratories, The University of Texas at Austin, Austin, TX.

HPS – Health Physics Society. 1999 (reissued 2011). *Sampling and Monitoring Releases of Airborne Radioactive Substances from the Stacks and Ducts of Nuclear Facilities*. ANSI/HPS N13.1–1999. McLean, VA.

HPS – Health Physics Society. 2011 (supersedes 1999 version). *Sampling and Monitoring Releases of Airborne Radioactive Substances from the Stacks and Ducts of Nuclear Facilities*. ANSI/HPS N13.1–2011. McLean, VA.

HPS – Health Physics Society. 2021. *Sampling and Monitoring Releases of Airborne Radioactive Substances from the Stacks and Ducts of Nuclear Facilities*. ANSI/HPS N13.1–2021. Herndon, VA.

Maiello ML and MD Hoover. 2011. *Radioactive Air Sampling Methods*. CRC Press, Taylor and Francis Group, Boca Raton, FL.

McFarland AR, A Mohan, NJ Ramakrishna, JL Rea, and J Thompson. 2000. “*Deposition 2001a, Version 1.0. Deposition: Software to Calculate Particle Penetration Through Aerosol Transportation Systems*.” NUREG/GR-0006. Texas A&M University, College Station, TX.

NRC – U.S. Nuclear Regulatory Commission. 1992. “Air Sampling in the Workplace.” *NRC Regulatory Guide 8.25*, Revision 1 (Reviewed with no issues identified May 2017). Washington, DC.

Pall Corporation. 2000. SLS Report No. 9069. Proprietary report furnished in confidence for the private use of Battelle Northwest, Scientific and Laboratory Services, Port Washington, NY.

PNNL – Pacific Northwest National Laboratory. 2021. “Create or Update Procedures and Other Work Instructions,” Revision 2.4. HDI, Pacific Northwest National Laboratory, Richland, WA.

PNNL – Pacific Northwest National Laboratory. 2018. “Statement of Work for Airborne Radionuclide Emission Sample Analysis.” EM/EPRP Procedure, Pacific Northwest National Laboratory, Richland, WA.

Snyder SF, PM Daling, and JM Barnett. 2021. *Determining Unabated Airborne Radionuclide Emissions Monitoring Requirements Using Inventory-Based Methods*. PNNL-10855, Rev. 7. Pacific Northwest National Laboratory, Richland, WA.

Snyder SF and DJ Rokkan. 2016. *Calculating Potential-to-Emit Radiological Releases and Doses*. DOE/RL-2006-29, Rev. 2. U.S. Department of Energy, Richland Operations Office,

Richland, WA.

Snyder SF and JM Barnett. 2016. *PNNL Campus Dose-per-Unit-Release Factors for Calculating Radionuclide Emissions Potential-to-Emit Doses*. PNNL-17847, Rev. 4. Pacific Northwest National Laboratory, Richland, WA.

WAC – Washington Administrative Code. 2007. *Ambient Air Quality Standards and Emission Limits for Radionuclides*, WAC 173-480, Olympia, WA.

WAC – Washington Administrative Code. 2018. *Operating Permit Regulation*. WAC 173-401, Olympia, WA.

WAC – Washington Administrative Code. 2019. *Radiation protection—air emissions*. WAC 246-247, Olympia, WA.

Appendix A

Particulate Sample Analysis and Data Evaluation

Appendix A: Particulate Sample Analysis and Data Evaluation

The Nuclear Chemistry & Engineering Group of the Radiochemical Processing Laboratory at Pacific Northwest National Laboratory (PNNL) performs particulate sample analyses. All analytical work associated with radionuclide sampling is performed according to required methods per the PNNL statement of work (SOW), [Airborne Radionuclide Emission Sample Analysis Statement of Work](#) (PNNL 2018). The SOW is prepared to meet the Quality Assurance (QA) requirements from the Analytical Support Operations QA Plan, [ASO-QAP-001](#), and conform to 40 CFR 61, Appendix B, Method 114 (EPA 2002b). Procedures for performing analyses are used and maintained by analytical laboratory staff.

After collection, the sample filter is stored for a minimum of 4 days and 10 hours to permit decay of radon and thoron daughter radionuclides. Each sample is individually counted for gross alpha and gross beta activity. The analytical laboratory staff use direct counting methods for total alpha and total beta activity using a gas-flow, proportional, alpha-beta counter (e.g., Oxford model LB4100). The counter is calibrated using ^{239}Pu for alpha and ^{90}Sr for beta. As specified in the SOW, sample (filter) counter minimum detectable activity levels of 0.7 pCi/single filter gross alpha and 9 pCi/single filter gross beta are required to be met by the analytical laboratory (PNNL 2018).

In addition to the above individual sample analyses, particulate samples from continuously sampled stacks are combined and analyzed semi-annually as a single “composite” sample for specific radionuclides as determined by the annual inventory assessment. A composite sample consists of 6-months’ worth of individual samples (typically January through June and July through December). Radionuclides identified by the assessment (e.g., from the Radioactive Material Tracking system) that contribute greater than 10% of the potential-to-emit (PTE) total effective dose equivalent (TEDE) to the maximally exposed individual (MEI) before controls, greater than 0.1 mrem/yr PTE TEDE to the MEI before controls, and greater than 25% of the TEDE to the MEI after controls for a release point are analyzed isotopically or as otherwise authorized by the Washington State Department of Health. Specific nuclide analysis is accomplished by destructive analysis of the filters. The analytical laboratory documents detection levels for specific isotope analysis performed and includes the appropriate quality control (QC) samples so that reasonable estimates of confidence in the data can be made. QC sample results are used to verify instrument control and detect out-of-control conditions.

The sample results obtained are used to evaluate existing facility emission levels and to calculate annual emission quantities for compliance determination and reporting purposes. Data are evaluated using documented and approved procedures. Data evaluation procedures are also based on guidance in DOE-HDBK-1216-2015 (DOE 2015).

Airborne emission sampling data are reviewed for anomalies and trends. Release data are updated periodically throughout the sampling year (calendar year). At the completion of the calendar year, data are reviewed, and results are finalized. Anomalous data are investigated and documented. Final release quantities include corrections for isokinetic sampling efficiency and sample transport losses, sample self-absorption, decay, counting efficiency, background, and collection media efficiency.

Appendix B

Tritium Sample Analysis and Data Evaluation

Appendix B: Tritium Sample Analysis and Data Evaluation

The Nuclear Chemistry and Engineering group performs tritium sample analyses. All analytical work associated with the tritium sampling is performed according to required methods per the Pacific Northwest National Laboratory (PNNL) statement of work (SOW), [Airborne Radionuclide Emission Sample Analysis Statement of Work](#) (PNNL 2018). The SOW is prepared to meet the quality assurance (QA) requirements from the Analytical Support Operations QA Plan, [ASO-QAP-001](#), and conform to 40 CFR 61, Appendix B, Method 114 (EPA 2002b). Procedures for performing analyses are used and maintained by analytical laboratory staff.

Tritium sample analysis consists of removing absorbed water vapor from silica gel columns by vacuum distillation. An aliquot of recovered water is analyzed for tritium content by liquid scintillation spectrometry. Instrument and reagent blanks are analyzed with each batch of samples counted for QA. As specified in the SOW, the minimum detectable activity for tritium in water is 27 pCi/mL (PNNL 2018). The PNNL tritium samplers are designed and operated to provide the required sample size (160 mL/month sample of water) (PNNL 2018). The sensitivity of the measurement is highly dependent on the water loading of the sampler, with analytical sensitivity indirectly proportional to sampler loading.

Tritium emission quantities for the collection period are calculated assuming complete retention of the sample in the collection column and multiplying the quantity of tritium collected in the column by the ratio of the stack flow rate to the sampler flow rate.

Results obtained from tritium sampling are used to evaluate existing facility emission levels and to calculate annual emission quantities for compliance determination and reporting purposes. Data are evaluated using documented and approved procedures.

Tritium emission sampling data are reviewed for anomalies and trends. The tritium released is updated periodically throughout the sampling year (calendar year). At the completion of the calendar year, data are reviewed, and the results are finalized. Anomalous data are investigated and documented. Final release quantities include corrections for counting efficiency, background, and sample-recovery efficiency. Additional information on tritium sampling and analysis is available in Barfuss (2007) and Barnett, True, and Douglas (2004).

Appendix C

Basis for Particle Line Loss Calculation

Appendix C: Basis for Particle Line Loss Calculation

Sampler transport efficiencies are calculated for all particulate sample systems with varying stack and sampler flow rates using procedure EPRP-AIR-014, *Line Loss Calculations for Radiological Air Emissions Monitoring*. The procedure was updated in early 2020 to embrace the use of available robust line loss software. Line-loss calculations are performed to evaluate the deposition of particles on sampling-system elements. The line-loss (particle deposition) calculation can be conducted by hand (Maiello and Hoover 2011); by software such as Deposition Calculator (Blunt 2016) or Deposition (DEPO) 5.0 (Haugland et al. 2010); or through experimental techniques (HPS 2011). Results are graphed for each system so that transport efficiencies can be more easily obtained over anticipated potential future stack and sampler flow rates. Copies of the applicable graphs and the line loss calculations are contained in the Effluent Management (EM) Rad Air File Plan. Table 1.6 summarizes the results of the total sample system efficiency calculations.

DEPO had been used prior to 2015 for line loss calculations based on the recommendations in Glismeyer 1991 (see Barnett and Snyder 2018). In 2015, Deposition Calculator (software) became available for use in place of the outdated DEPO software. Deposition Calculator software is for evaluating the penetration of an aerosol through an aerosol sampling system. It is a complete rebuild of the DEPO software. The Deposition Calculator Technical Description Manual (Blunt 2015) and the Deposition Calculator User's Manual (Blunt 2016) are available to the user for future line loss calculations. The Deposition Calculator software is available for download at bluntconsulting.com (last accessed November 22, 2021). The penetration of particles with an aerodynamic diameter of 10 micrometers should be at least 50% as stated in the Nuclear Regulatory Commission (NRC) Regulatory Guide 8.25 (NRC 1992) and in ANSI/HPS N13.1-2011 (HPS 2011).

Appendix D

PNNL Operated Stack Sampler Systems

Appendix D: PNNL Operated Stack Sampler Systems

This appendix describes the buildings, exhaust units, control technologies, and sample extraction details for each Pacific Northwest National Laboratory (PNNL) facility emission unit. Section D.1 provides details for Hanford Site emission unit systems. Section D.2 provides details for PNNL-Richland Campus systems. There are currently no emission unit sampler systems at the PNNL-Sequim Campus.

D.1 Hanford Site Sampler Systems

A description of the buildings, exhaust units, control technologies, and sample extraction details for each Hanford Site PNNL operated emission unit is provided. Applicable stack sampler configuration drawings, figures, and photographs are provided for the following U.S. Department of Energy emission units:

- EP-325-01-S and
- EP-331-01-V

D.1.1 Emission Unit EP-325-01-S: Radiochemical Processing Laboratory



Facility/Process Description

The Radiochemical Processing Laboratory (RPL) (325 Building) operations involve radiochemical process science and engineering; evaluation, analysis, and testing of radioactive, radiochemical, chemical, and physical material properties; development and experimentation in the design and application of radiation generating devices; and the development and conduct of analytical procedures in support of research activities. RPL special capabilities include two hot cell complexes and general laboratory spaces in which process development and analytical work can be performed.

Emission Unit Specifics

Air exhausts through EP-325-01-S from areas inside of the 325 Building where radionuclides are handled and used, which include fume hoods, glove boxes, hot cells, and other work spaces. The exhaust stream passes through two stages of high-efficiency particulate air (HEPA) filters located upstream of the exhaust fans. The stack is located on the northwest corner of the 325 Building. Operating characteristics are provided below.

Emission Unit ID	EP-325-01-S
Emission Sample Unit ID	ESP-325-01-S
Traverse Point ID	TP-325-01-1
Stack Height	27.1 m (88.8 ft)

Stack Diameter	2.44 m	(8 ft)
Average Volumetric Flow Rate (5 yr average, 2016-20)	67.5 m ³ s ⁻¹	(142,970 cfm)
Exhaust Velocity	14.1 m s ⁻¹	(46.5 ft s ⁻¹)
Fan Rated Maximum (single fan)	26.0 m ³ s ⁻¹	(55,000 cfm)
Cross Sectional Area	4.68 m ²	(50.3 ft ²)
Average Stack Temperature (5 yr average, 2016-20)	25°C	(77°F)
Operating Temperature Range	18.3 – 26.1°C	(65 – 79°F)
Effective Stack Height	83.0 m	(272 ft)
HEPA Filter Design Efficiency	≥ 99.90%	
Latitude	46.369 North	
Longitude	119.279 West	

Exhaust Unit Control Technology

The following simplified drawing shows the effluent pathway and the installed control technology for the 325 Building emission unit:

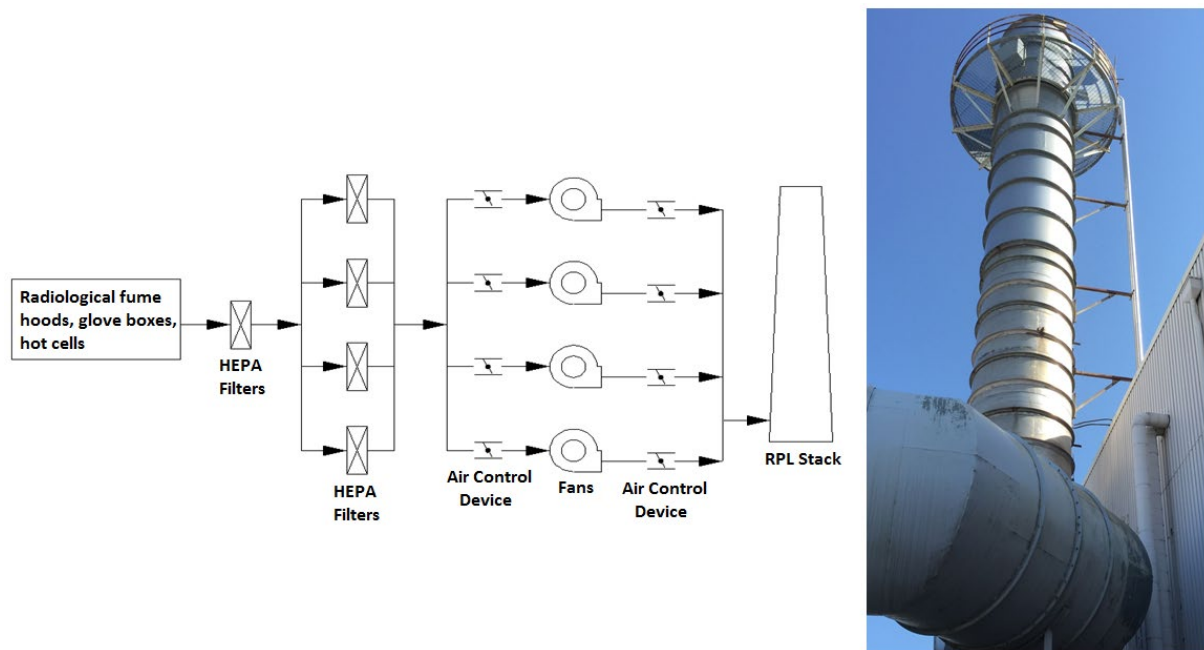

Figure D.1. 325-01-S Building Effluent Pathway

Exhaust Unit Flow Rate and Temperature

In 2012, the RPL sampling system was upgraded to the radiological air emissions sampling (RAES) system, which is used to determine exhaust flow rates. An average annual flow rate is calculated and is reported in the Hanford Site Annual Report. The average flow rate reported in Table 1.5 is used to calculate the effective release height in the same table. An annual verification check of the RAES system is performed using [EPRP-AIR-016](#), *PNNL Stack/Duct*

Velocity Traverse Method. The following tables provide historical flow rate and temperature measurements.

Table D.1. 325-01-S Building Exhaust Unit Flow Rate (from traverse data and as reported in the Hanford Site Annual Air Emissions Report)

Date Measured	Traverse Data Flow Rate (cfm)	Hanford Site Annual NESHAP Report Average Flow Rate (cfm)
05/21/16	137,600	142,500
05/20/17	142,100	143,900
05/19/18	142,100	135,427
05/18/19	141,800	144,100
06/06/20	144,600	148,942
2016-20 average ± st.dev.	141,640 ± 2530	142,974 ± 4871

Data have been truncated to the last 5 completed calendar years.

Average and standard deviation determined from traverse data. Standard deviation determined with Excel STDEVA function of the indicated annual values.

Table D.2. 325-01-S Building Exhaust Unit Temperature (from traverse data)

Date Measured	Average Temperature (°F)
05/21/16	73
05/20/17	77
05/19/18	80
05/18/19	80
06/06/20	76
2016-20 average ± st. dev.	77 ± 2.9

Record Particulate Sample System Description

The emission unit EP-325-01-S record particulate sampling system operates in conformance with 40 CFR 61, Subpart H (EPA 2002a), and the ANSI/HPS N13.1–2011 (HPS 2011) standard requirements. The sampling unit is located in Room 916 of the 325 Building. Continuous sampling is conducted for particulates, and samples are collected using a shrouded probe mounted in the center two-thirds of the exhaust stack.

A stainless steel single shrouded sample probe supplied by Air Monitor Corporation is used to extract a representative sample from the center two-thirds of the duct. The sample probe is 16.88 in. long and is positioned in line to the direction of flow before it makes a 90 degree, 5-in. radius of curvature bend perpendicular to the stack and intersects the stack sidewall 48 in. away. It is positioned 55.9 ft from the nearest flow disturbance and 8 ft from the top of the stack; it is located 80.83 ft above ground level. The single nozzle inlet has a 1.12-in. inside diameter (ID).

The sample transport line is constructed of 1.12-in. ID stainless steel tubing. After connecting to the shrouded probe, the sample line makes a bend of 5 degrees with a 4-in. radius of curvature before, it makes a 90 degree, 12-in. radius of curvature bend downward. The line extends

downward and terminates in Room 916, which contains the collection filter and multi-point mass flow transmitter. The sample line upstream of the roof penetration is insulated, heat taped, and electrically grounded. The heat tape and grounding are inspected per internal preventive maintenance measures. An annual pressure test is conducted to confirm that no leaks formed during the previous year.

Vacuum Air Sample System

Stack emission record samples and continuous air monitoring are withdrawn from the stack and through the sample systems by means of the building vacuum air sampling system, located in the basement of the 325 Building. This system has redundant vacuum pumps that are powered by normal and emergency power. Preventive maintenance of the vacuum air sampling system is performed in accordance with a documented preventive maintenance program.

Sample Collection

Particulate sample collection. Particulate samples are collected using a 47-mm supported membrane filter (Pall Versapor-Membrane, acrylic copolymer membrane filter) mounted in a modified sample holder. The membrane filter has estimated retention efficiency of greater than 99% for 0.3- μ particles.



Continuous sampling is conducted for particulates, and samples are collected using a shrouded probe located in the center two-thirds of the exhaust stack. The sampling system is designed and constructed in accordance with ANSI/HPS N13.1–2011 (HPS 2011). The sample line temperature is maintained above that of the stack gas to prevent losses due to condensation forming in the sample line. The radiological air emissions sampling operates under variable flow rates and temperature conditions. Samples of particulate matter are collected on membrane filters. The confirmatory demonstration of compliance is performed against previously proven testing data of similar design. The sampling system components are calibrated annually. Inspections of the sampling system are performed before initiating sampling events and daily (excluding holidays and weekends) during sample collection.

Tritium sample collection. Tritium samples are drawn through the same sample probe and transport line as the record particulate samples. Tritium as water vapor (HTO) and tritium gas (HT) is sampled continuously using a two-stage sampling system located in the 325 Building, Room 916. The sample is drawn downstream of the record particulate sampling system and uses the same sample extraction and transport system as the particulate sampler. See Stack Sampling/Monitoring System Flow Diagram Drawing #H-3-70531-1. The tritium sample extraction unit, tritium sample extraction probe, tritium sample transport line, and vacuum air sample system are the same as the particulate sampling data. The record particulate sample collector acts as a pre-filter for the tritium sample stream, and the flow is measured using a calibrated rotameter. The subsample flow rate to the tritium sampler is a nominal 200 mL/min (nominal 0.007 cfm).

Tritium vapor sampling is done in the first stage and tritium gas sampling, after conversion to a vapor, is done in the second stage of this sampling system. Upstream of the first tritium collection unit, a nitrogen-hydrogen carrier gas (3% H₂ in N₂) is added to the tritium sample stream via a tee in the sample line. The tee in the sample line is just upstream of the carrier gas rotameter SM-9-RM. The mixed sample and carrier gas then first enters a three-column silica gel tritium collection unit, where silica gel is used to absorb water vapor from the gas stream. On exit from the first collection unit, the now-dry sample stream is heated to >180°C in the presence of a palladium catalyst to convert free hydrogen (HT and TT) to water vapor. The sample stream is then cooled to less than 40°C and passed through the second tritium collection unit, which consists of a two-column silica gel tritium collection unit. This second collection unit absorbs out the water vapor generated from the catalytic oxidation of free hydrogen. The picture below shows two-stage sampling system with its three-column and two-column tritium collection units.

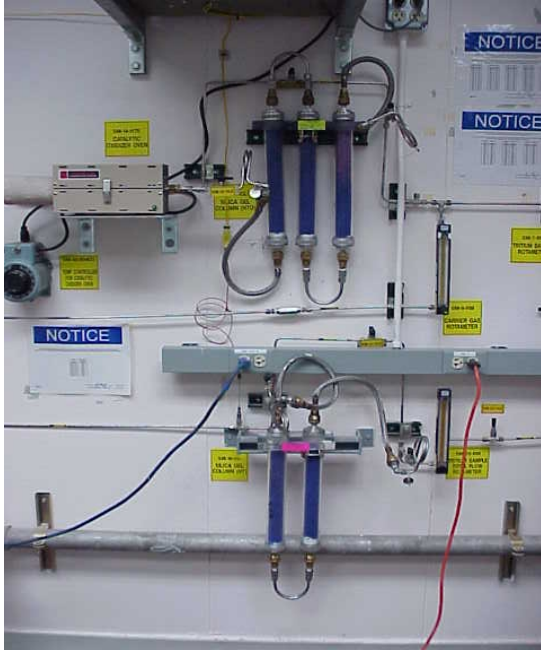

Samples are exchanged about monthly or until the silica gel cartridge loading sampling system meets or exceeds two-thirds loading (based on color change), whichever comes first. Following the sampling collection, the samples are delivered to the analytical laboratory for analysis of the tritium content. The sample system is inspected each workday, excluding weekends and holidays, for proper flow-rate settings and system operation.

Thermocouples and associated digital temperature displays are either calibrated in place or replaced with calibrated spares on an annual basis. PNNL Maintenance Services performs these per group-specific procedures.

Rotameters that measure sample and carrier gas flows are exchanged with calibrated spares on an annual basis. An approved calibration laboratory performs calibration on these instruments.

See Appendix B for analysis and data evaluation requirements for tritium samples collected from this major emission unit.

Continuous air monitoring particulate sample collection. The 325 Building stack particulate continuous air monitoring (CAM) system for emission unit EP-325-01-S is operated in conformance with 40 CFR 61, Subpart H (EPA 2002a), and ANSI/HPS N13.1–2011 (HPS 2011) requirements. See Stack Sampler Configuration Drawing H-3-307232-1.



Stack air is continuously monitored for radioactivity associated with particulate matter by an EG&G-Berthold LB150D alpha-beta-pseudocoincident monitor and a PNNL OS3300 software particulate analyzer. The monitor uses an 8-in.-diameter glass-fiber filter to collect airborne particles from the stack. The filter is mounted against a sandwich arrangement of gas-flow proportional radiation detectors to count the alpha, beta, and gamma emissions as particles accumulate on the filter.

The monitoring system accounts for the presence of radioactive material associated with the decay products of naturally occurring radon isotopes by means of a timing gate to identify simultaneous alpha and beta emissions occurring on the filter. Referred to as the alpha-beta-pseudocoincidence-difference method, it uses the nearly simultaneous (pseudocoincident) alpha-beta decay transitions in the ^{220}Rn and ^{222}Rn decay chains as a means of distinguishing naturally occurring radionuclides from artificial radionuclides deposited on the sample filter. Three gas-flow proportional counters in a sandwich configuration independently count the number of alpha, beta, and gamma emissions on the sample collection filter. In addition, alpha and beta emissions that are detected pseudocoincidentally are also counted. The number of pseudocoincident events multiplied by a scaling factor is subtracted from the total alpha and beta counts to yield the net event detections attributed to sources other than radon isotopes.

The data from the detectors are fed to the PNNL OS3300 software analyzer unit via coaxial cables. The analyzer provides the output for the video display along with a web-based tool designed to provide real-time remote access to the data via the PNNL network services.

Local and remote annunciators provide indications of high particulate radionuclide emissions as well as monitor component failures.

A stainless steel six-nozzle probe originally designed by Kurz Instruments, Inc. was provided by Air Monitor Corporation and is used to extract the sample. Each nozzle inlet has a 0.494-in. ID. The nozzles feed into a 1.87-in. ID sample manifold that spans the stack cross-section. See vendor-supplied drawings for details: W74103AC, Rev. 2, and W74103AB, Rev.0. The sample is extracted from the stack about 80.83 ft above ground level. The continuous monitoring system is designed and constructed in accordance with ANSI/HPS N13.1–2011 (HPS 2011).

The sample transport line is constructed of 2.83-in. ID stainless steel tubing. The line makes a 90 degree, 7.5-in. radius of curvature bend downward upon exiting the stack and makes a 5-in. curvature ratio bend to horizontal before entering into the EG&G Berthold alpha/beta CAM, which is located in the 325 Building, Room 916. The sample line upstream of where it penetrates the building roof is insulated, heat traced, and electrically grounded. The sample line temperature is maintained above that of the stack gas to prevent condensation from forming in the sample line.

A particulate sample is collected on an 8-in. glass-fiber filter housed in the alpha/beta CAM. Schleicher & Schuell manufacture the media. The sample flow rate is measured by a Brooks Instrument GT-1000 (3.21 to 32.15 scfm) rotameter and adjusted using a throttle valve (both located just downstream of the CAM outlet). A vacuum gauge (0 to 100 in. of water) is installed on the inlet side of the rotameter and used to correct the sample flow for vacuum conditions. A 1-month particulate sample is collected continuously to measure in real time the actual emissions from the facility. Monitor flows are at or near the isokinetic range of 22 scfm. The monitoring system is inspected each workday (excluding weekends and holidays) for proper flow-rate settings and system operation.

The rotameter and vacuum gauge are exchanged on an annual basis with calibrated spares. An approved calibration laboratory performs calibration on these instruments. Electronic calibration of the alpha/beta CAM is conducted annually or when failures or modifications of the system occur. PNNL Maintenance Services performs these calibrations per group-specific procedures.

Radiological calibration of the alpha/beta CAM is performed on an annual basis or when failures or modifications of the system occur. PNNL Radcon Instrumentation Services performs these calibrations per group-specific procedures.

Particulate monitor alarm setpoints are addressed in the current version of the “Adjustment to Alpha CAM Alarm Setpoint” document. See the Effluent Management (EM) File Plan or contact EM staff to access documentation.

Continuous air monitoring tritium sample collection. The 325 Stack Tritium CAM system for emission unit EP-325-01-S is operated in conformance with applicable regulatory requirements and license conditions. In addition, sampling and monitoring methods found in DOE-HDBK-1216-2015, *Environmental Radiological Effluent Monitoring and Environmental Surveillance* (DOE 2015), are applied as appropriate. The continuous monitoring system is designed and constructed in accordance with ANSI/HPS N13.1–2011 (HPS 2011).

Stack air is continuously monitored for tritium by an EG&G-Berthold LB110 tritium detector and a PNNL OS3700 software tritium analyzer. The LB110 is a windowless, flow-through proportional detector with pulse rise-time discrimination. The discriminator divides individual ionization events into short rise-time events and long rise-time events. Short rise-time events are counted as tritium, while long rise-time events are currently calibrated to Kr-85.

The data from the discriminator are fed to the PNNL OS3700 software analyzer unit via coaxial cables. The analyzer is used to allow for subtracting background, accumulating pulse events, and converting those events to concentration. The analyzer also provides the output for the video display along with a web-based tool designed to provide real-time remote access to the data via the PNNL network services.

P-10 gas is mixed with the sample stream in a 4:1 ratio and passed through the detector. The P-10 gas is used to maximize sensitivity and minimize interference from other decays.

Local and remote annunciators provide indications of high tritium emissions, monitor component failures, and sample and P-10 flow transients lasting more than 60 seconds.

A stainless steel six-nozzle probe originally designed by Kurz Instruments, Inc. was provided by Air Monitor Corporation and is used to extract the sample. Each nozzle inlet has a 0.494-in. ID. The nozzles feed into a 1.87-in. ID sample manifold that spans the stack cross-section. See vendor-supplied drawings for details: W74103AC; Rev. 2, and W74103AB; Rev. 0. The sample is extracted from the stack about 80.83 ft above ground level.

The sample transport line is constructed of 2.83-in. ID stainless steel tubing. The line makes a 90 degree, 7.5-in. radius of curvature bend downward upon exiting the stack and a 5-in. radius bend to horizontal before entering the EG&G Berthold alpha/beta CAM. The CAM is also located in the 325 Building, Room 916. The tritium CAM draws a sample just downstream from the alpha/beta CAM filter media. The sample line upstream of where it penetrates the building roof is insulated, heat traced, and electrically grounded. The sample line temperature is maintained above that of the stack gas to prevent condensation from forming in the sample line.

A sample is drawn by means of a membrane pump internal to the CAM from a point downstream of the alpha/beta CAM filter media. The sample and counting gas (P-10) flow are measured separately and kept constant by a control circuit. The measurement is performed by means of floating body flow-through meters using photoelectronic positioning scanning. A needle valve operated by a stepper motor serves as the control element. A sample is collected on a continuous basis to measure in real time the actual emissions from the facility. The sample line upstream of where it penetrates the building roof is insulated, heat traced, and electrically grounded. The sample line temperature is maintained above that of the stack gas to prevent losses caused by condensation forming in the sample line.

Electronic calibration of the tritium CAM is performed on an annual basis or when failures or modifications of the system occur. PNNL Maintenance Services performs these calibrations per group-specific procedures.

Radiological calibration of the tritium CAM is performed on an annual basis or when failures or modifications of the system occur. PNNL Radcon Instrumentation Services performs these calibrations per group-specific procedures.

Tritium monitor alarm setpoints are addressed in the current version of the “Tritium Monitor Alarm Setpoint Revision Radiochemical Processing Facility Exhaust Stack” document. See EM File Plan or contact EM staff to access documentation.

Radon (sample collection) reporting. Radon emissions are reported and conservatively calculated in lieu of sampling. Actual radon releases are entered into the Radioactive Air Emissions Gas Database (<http://ragas.pnl.gov/>). Radon isotopes are calculated from operating activities assuming secular equilibrium with its radium parent when opened. The overall operating time for the work evolution is used to calculate how much radon daughter is generated during the work evolution and added to the starting value. The sum of radon in secular equilibrium with the radon generated is reported as a 100% release through the emission point. This process is more conservative than charcoal canister sampling/monitoring and/or cryogenic capture sampling of the specific radon isotopes at the emission point sampling location.

The radon emissions mitigation strategy considered a radon hold-up system, time management of potential releases, and a “do-nothing” approach in association with a conservative 100% calculated release approach to emissions reporting and management. A radon hold-up system would essentially remove >90% of all radon from the ventilated air space; however, worker doses would be substantially increased, making such systems impractical in principle. Several processes for the purification of radon parent material have been reviewed and cold-testing (i.e., non-radioactive) has been conducted that demonstrates proof of principle. Initial cold tests showed process times of up to 3 weeks, resulting in very large quantities of calculated radon emissions; refinements include the addition of heat (e.g., drying lamps, hot plates) and process improvements, resulting in shorter processing times of 2 or 3 days. A do-nothing tactic does not capture, slow down, or mitigate any potential radon emissions. In reviewing the radon mitigation

strategies, the As Low As Reasonably Achievable Control Technology (ALARACT) principles for both worker and environmental protection were considered, resulting in the selection of the time management of potential releases, which minimizes the overall radon released during any particular work evolution.

Battelle Drawings

	<u>Number</u>
Stack Sampler Configuration EP-325-01-S	H-3-307232-1
Vacuum Air Sampling One-Line Diagram	H-3-307547-1
Stack Sampling/Monitoring System Flow Diagram	H-3-70531-1
Mechanical/Electrical Stack Monitor	H-3-316015
Stack Sampler Configuration Shrouded Probe/Radiation Monitor	H-3-317518
HVAC MISC Details and Schedules (Exhaust Fan=55,000 cfm)	H-3-22617-1

Note: The fan nameplate indicates 42,630 cfm (20.1 m³ s⁻¹)

Electronic access to these drawings is available.

Air Monitor Corp. Drawings

VOLU-probe/ISS With Sampler Probe Top Assembly	W74103BA; Rev. 2
VOLU-probe/ISS With Sampler Probe Gen. Arrangement	W74103AC; Rev. 2
Sampling System Particle Loss Dimensions	W74103AB

D.1.2 Emission Unit EP-331-01-V: Life Sciences Laboratory I



Facility/Process Description

The Life Sciences Laboratory I (331 Building) provides research capabilities to study the interactions of chemicals and radionuclides with plants, animals, and microorganisms and the fate of chemicals and radionuclides in the environment. The mission of the 331 Building is to conduct fundamental science and to develop environmental technology to include investigating health risks associated with internal and external radiation exposures, and experimental studies to understand the microbial process in the range of ecosystems, focusing on potential interaction with Hanford sediment legacy waste and other subsurface issues. Other areas of research capabilities include characterizing and monitoring of aquatic and terrestrial ecosystems, with a focus on impacts of water use practices on fisheries and wildlife.

Emission Unit Specifics

Air exhausts through EP-331-01-V from areas inside of the 331 Building where radionuclides are handled and used, which include fume hoods and other work spaces. The exhaust stream passes through HEPA filters located upstream of the exhaust fans. Operating characteristics are provided below. The stack extends 7.5 m (24.75 ft) above the rooftop.

Emission Unit ID	EP-331-01-V	
Emission Sample Unit ID	ESP-331-01-D	
Traverse Point ID	TP-331-01-1	
Stack Height	18.9 m	(62 ft)
Stack Diameter	1.98 m	(6.5 ft)
Average Volumetric Flow Rate (5-yr average, 2016-20)	29.6 m ³ s ⁻¹	(62,720 cfm)
Exhaust Velocity	9.9 m s ⁻¹	(32.3 ft s ⁻¹)
Fan Rated Maximum (single fan)	15.1 m ³ s ⁻¹	(32,000 cfm)
Cross Sectional Area	3.08 m ²	(33.2 ft ²)
Average Stack Temperature (5-yr average, 2016-20)	23°C	(73°F)
Operating Temperature Range	14.4 – 27.8°C	(58 – 82°F)
Effective Stack Height	50.3 m	(165 ft)
HEPA Filter Design Efficiency	≥ 99.90%	
Latitude	46.365 North	
Longitude	119.271 West	

Exhaust Unit Control Technology

The following simplified drawing shows the effluent pathway and the installed control technology for the 331 Building emission unit:

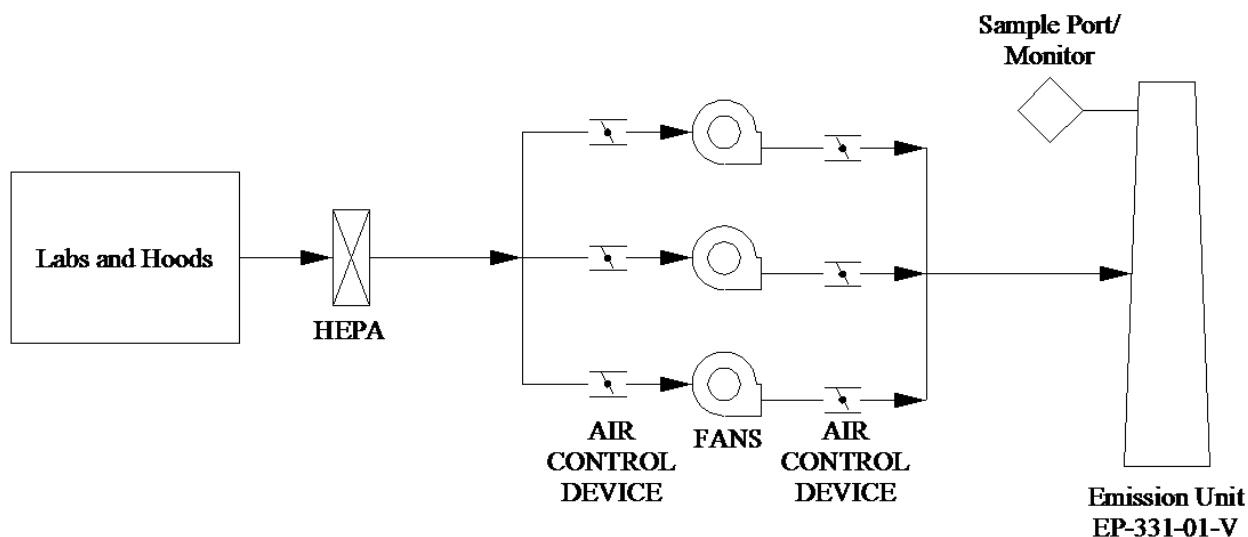

Figure D.2. 331-01-V Building Effluent Pathway

Exhaust Unit Flow Rate and Temperature

Exhaust flow rates are determined quarterly using EM procedure [EPRP-AIR-016](#), *PNNL Stack/Duct Velocity Traverse Method*, which was developed based on the requirements in 40 CFR 60, Appendix A, **Method 2** (EPA 2014). The following tables provide historical flow-rate measurements and temperature readings.

Table D.3. 331-01-V Building Exhaust Unit Flow Rate (from traverse data and as reported in the Hanford Site Annual Report)

Date Measured	Flow Rate (cfm)	Hanford Site Annual NESHAP Report Flow Rate (cfm)
03/31/16	60,100	--
06/21/16	61,600	--
09/14/16	62,400	--
12/21/16	61,100	61,600
03/23/17	62,300	--
06/14/17	64,400	--
09/12/17	63,200	--
12/20/17	62,700	62,700
03/29/18	63,100	--
06/12/18	61,600	--
09/20/18	63,400	--
12/21/18	61,300	62,700
03/26/19	61,900	--
06/05/19	64,100	--
09/13/19	65,600	--
12/20/19	62,700	63,480
03/06/20	63,100	--
07/07/20	63,900	--
10/09/20	63,200	--
12/08/20	60,100	63,123
2016-20 average ± st.dev.	62,590 ± 1400	62,720 ± 700

Data have been truncated to the last 5 completed calendar years.
Average and standard deviation determined from traverse data. Standard deviation determined with Excel STDEVA function of the indicated annual value.

Table D.4. 331-01-V Building Exhaust Unit Temperature

Date Measured	Average Temperature (°F)
03/31/16	77
06/21/16	72
09/14/16	77
12/21/16	71
03/23/17	75
06/14/17	73
09/12/17	72
12/20/17	72
03/29/18	72
06/12/18	73
09/20/18	71
12/21/18	70
03/26/19	72
06/05/19	76
09/13/19	77
12/20/19	72
03/06/20	75
07/07/20	74
10/09/20	75
12/08/20	73
2016-20 average ± st.dev	73 ± 2.2

Record Particulate Sample System Description

The record particulate sampling system for emission unit EP-331-01-V is operated in conformance with 40 CFR 61, Subpart H (EPA 2002a), and ANSI N13.1–1969 (ANSI 1970) requirements. See Stack Sampler Configuration Drawing H-3-307236-1.

The sample is extracted from a section of horizontal duct located on the roof of the 331 Building. The sample probe is positioned about 52 ft (8.0 equivalent diameters) downstream of a flow disturbance and 14 ft, 11 in. (2.3 equivalent diameters) to a downstream disturbance where the duct makes a 10-ft radius bend upwards. The sample extraction point position meets the 8:2 (downstream:upstream) duct-diameter placement recommendation from ANSI N13.1–1969 (ANSI 1970).

A stainless steel six-nozzle probe manufactured by Air Monitor Corporation is used to extract the sample. Each nozzle inlet has a 0.237-in. ID. The six sample nozzles feed into a 1.12-in. ID manifold that extends horizontally across the center of the duct. See vendor-supplied drawings for details.

The sample transport line is constructed of 1.25-in. stainless steel tubing. The line extends outside of the duct approximately 2.375 ft before terminating in a waterproof cabinet containing the collection filter, rotameter, and sample flow rate adjustment valve. The sample line is insulated, heat traced, and electrically grounded. The sample line temperature is maintained above that of the stack gas to prevent condensation from forming in the sample line.

Vacuum Air Sample System

Stack emission samples are withdrawn from the stack and through the sample system by means of the building vacuum air sampling system located in the second floor equipment room of the 331 Building. This system has redundant blowers that are powered by normal and emergency power. See Vacuum Air Sampling One-Line Diagram Drawing H-3-307559-1 for details.

Sample Collection

The record particulate sampling system was constructed in conformance with ANSI N13.1–1969 (ANSI 1970) requirements. Samples are collected using a sample probe that has six nozzles, with each nozzle sampling an equal annular space within the stack. The probe in the stack is located to meet the 8:2 (downstream:upstream) duct-diameter placement recommendation from ANSI N13.1–1969 (ANSI 1970). The sampling system components (rotameter and vacuum gauge) are calibrated annually. Inspections of the sampling system are performed prior to initiating a sampling event and every day (excluding holidays and weekends) during sample collection.

Battelle Drawings

Stack Sampler Configuration EP-331-01-V
Vacuum Air Sampling One-Line Diagram

Number

H-3-307236-1
H-3-307559-1

Electronic access to these drawings is available.

Air Monitor Corp. Drawings

Iso-Sampling Threaded Nozzle; Rev. 1

Number

HVAC-ISOKINETIC PROBE
(W20628EA)

Other drawings are provided by the vendor and are not available electronically at this time.

D.2 PNNL-Richland Campus Stack Sampler Systems

A description of the buildings, exhaust units, control technologies, and sample extraction details for each PNNL-Richland Campus sampled emission unit is provided. Additionally, applicable stack sampler configuration drawings, figures, and photographs are provided for the following emission units:

- EP-3410-01-S,
- EP-3420-01-S, and
- EP-3430-01-S.

D.2.1 Emission Unit EP-3410-01-S: Materials Science and Technology



Facility/Process Description

The 3410 Building contains research laboratories that evaluate the performance of materials for applications in high-temperature, corrosive, and/or radiation environments. Capabilities include radiation materials science to evaluate the aging and degradation of materials in nuclear systems and to develop radiation-resistant structural materials for advanced fission and fusion reactors; synthesis, characterization, and performance of irradiated and un-irradiated materials for applications at temperatures where properties begin to change; investigations of fundamental

mechanism of materials corrosion and stress corrosion cracking in nuclear reactor environments; and computational materials science for radiation effects modeling to understand and predict materials behavior.

Emission Unit Specifics

The design of the 3410 Building specifies that all HEPA filtered radiological areas exhaust through a single emission unit: EP-3410-01-S. Single-stage HEPA filters control radiological exhaust using two of three variable air flow exhaust fans operating at any one time during normal operations. Operating characteristics are provided below.

Emission Unit ID	EP-3410-01-S	
Emission Sample Unit ID	ESP-3410-01-S	
Traverse Point ID	TP-3410-01-1	
Stack Height	13.5 m	(44.4 ft)
Stack Diameter	1.02 m	(3.33 ft)
Average Volumetric Flow Rate (5-yr average, 2016-20)	9.91 m ³ s ⁻¹	(21,000 cfm)
Exhaust Velocity	14.2 m s ⁻¹	(47.1 ft s ⁻¹)
Fan Rated Maximum (single fan)	13.2 m ³ s ⁻¹	(28,000 scfm)
Cross Sectional Area	0.82 m ²	(8.7 ft ²)
Average Stack Temperature (5-yr average, 2016-20)	23°C	(75°F)
Operating Temperature Range	18.3 – 25.6°C	(65 – 78°F)
Effective Stack Height	33.9 m	(111 ft)
HEPA Filter Design Efficiency	≥ 99.90%	
Latitude	46.352 North	
Longitude	119.276 West	

Exhaust Unit Control Technology

The following simplified drawing shows the effluent pathway and the installed control technology for the 3410 Building emission unit:

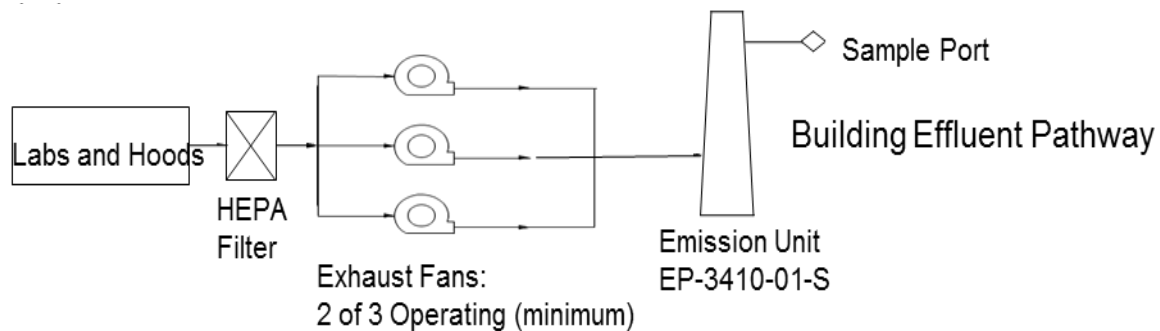

Figure D.3. 3410-01-S Effluent Pathway

Exhaust Unit Flow Rate

Exhaust flow rates are determined using data collected from the RAES system. An average annual flow rate is calculated and reported in the PNNL Campus Annual Report. The average flow rate is reported in Table 1.5 and is used to calculate the effective release height in the same table. An annual verification check of the RAES system is performed using [EPRP-AIR-016](#), *PNNL Stack/Duct Velocity Traverse Method*. The following tables provide flow rate and temperature measurements.

Table D.5. 3410-01-S Building Exhaust Unit Flow Rate (from traverse data and as reported in the PNNL-Richland Campus Annual Report)

Date Measured	Flow Rate (cfm)	PNNL Campus Annual Report Average Flow Rate (cfm)
05/25/16	21,300	21,700
06/02/17	22,100	20,570
11/26/18	22,600	20,720
05/31/19	21,600	20,960
04/10/20	23,600	20,825
2016-20 average \pm st.dev.	22,200 \pm 907	21,000 \pm 440

Data have been truncated to the last 5 completed calendar years.
Average and standard deviation determined from EPRP-AIR-016 traverse data and from annual reporting. Standard deviation determined with Excel STDEVA function of the indicated annual value.

Table D.6. 3410-01-S Building Exhaust Unit Temperature (from traverse data)

Date Measured	Temperature (°F)
05/25/16	72
06/02/17	85
11/26/18	61
05/31/19	88
04/10/20	72
2016-20 average \pm st.dev.	75 \pm 11

Record Particulate Sample System Description

The record particulate sampling system for emission unit EP-3410-01-S operates in conformance with 40 CFR 61, Subpart H, and ANSI/HPS N13.1-2011 (HPS 2011) requirements. See Stack Sampler Configuration Drawing H-3-312451. A record particulate sampling system samples the exhaust from emission unit EP-3410-01-S in conformance with 40 CFR 61, Subpart H (EPA 2002a). A shrouded probe mounted in the center two-thirds of the exhaust stack conducts continuous sampling for particulates and samples.

A stainless steel shrouded probe supplied by Air Monitor Corporation is used to extract the sample. The single nozzle inlet has a 1.225-in. ID. The sample nozzle is tapered and feeds into a 1.125-in. ID transport line that is run on a horizontal plane across the stack. See vendor-supplied drawing (W68683AD) for details.

The sample transport line is constructed of 1.12-in. ID stainless steel tubing. The line extends 0.49 in. outside of the duct and terminates in a heated cabinet containing the sample collection filter, flowmeters, and adjustment valves. The sample line temperature is maintained above that of the stack gas to prevent condensation from forming in the sample line.

Vacuum Air Sample System

A single Airtech Inc. regenerative pump located in the second floor equipment room supplies the vacuum to the sample system. This system is powered by normal power.

Sample Collection

A shrouded probe mounted in the center two-thirds of the exhaust stack conducts continuous sampling for particulates and samples. The sampling system is designed and constructed in accordance with ANSI/HPS N13.1–2011 (HPS 2011). The radiological air emissions sampling operates under variable volume and temperature conditions. Membrane filters collect samples of particulate matter. The confirmatory demonstration of compliance is performed against previously proven testing data of similar design. The sampling system components are calibrated annually. Sampling system inspections are performed before initiating sampling event and daily (excluding holidays and weekends) during sample collection.

Battelle Drawings

	<u>Number</u>
Mechanical MEP Section Stack Height	H-3-312451
Mechanical Control Diagrams Air System	H-3-312471
Plumbing Vacuum Air Diagram	H-3-312546

Electronic access to these drawings is available.

Air Monitor Corp. Drawings

	<u>Number</u>
Flow & Sampler Probes General Arrangement	W68683AD

Other drawings are provided by the vendor and are not available electronically at this time.

D.2.2 Emission Unit EP-3420-01-S: Radiation Detection Building



Facility/Process Description

The 3420 Building contains research laboratories that perform a wide variety of radionuclide measurements. Capabilities used or under development would include state-of-the-art analytical chemistry, radiation physics, light detection, particle detection, chromatography, scintillation materials, sorbents materials, and field-deployable forensics instrumentation. Applications for these capabilities range from fundamental science, such as neutrino mass detection, to applied systems for prevention of nuclear proliferation and radiation portal monitoring at U.S. borders. A remodel in 2020 added an additional fan and air blender to this stack.

Emission Unit Specifics

The design of the 3420 Building specifies that all HEPA filtered radiological areas exhaust through a single emission unit: EP-3420-01-S. Single-stage HEPA filters control radiological exhaust using up to four variable air flow exhaust fans operating at any one time. Operating characteristics are provided below.

Emission Unit ID	EP-3420-01-S
Emission Sample Unit ID	ESP-3420-01-S
Traverse Point ID	TP-3420-01-1
Stack Height	15.5 m (50.9 ft)
Stack Duct Diameter	1.57 m (5.17 ft)

Exhaust Diameter (cone)	1.32 m	(4.33 ft)
Average Volumetric Flow Rate (5 yr average, 2016-20) ¹	23.9 m ³ s ⁻¹	(50,650 cfm)
Approximate Volumetric Flow Rate (new ± 10%)	33.0 m ³ s ⁻¹	(70,000 cfm)
Exhaust Velocity (new)	17.1 m s ⁻¹	(55.6 ft s ⁻¹)
Fan Rated Maximum (single fan)	11.8 m ³ s ⁻¹	(25,000 scfm)
Cross Sectional Area of Stack Duct	1.94 m ²	(21.0 ft ²)
Average Stack Temperature (5-yr average, 2016-20)	23°C	(74°F)
Operating Temperature Range	18.3 – 25.6°C	(65 – 78°F)
Effective Stack Height	49.9 m	(64 ft)
HEPA Filter Design Efficiency	≥ 99.90%	
Latitude	46.353 North	
Longitude	119.276 West	

Exhaust Unit Control Technology

The following simplified drawing shows the effluent pathway and the installed control technology for the 3420 Building emission unit:

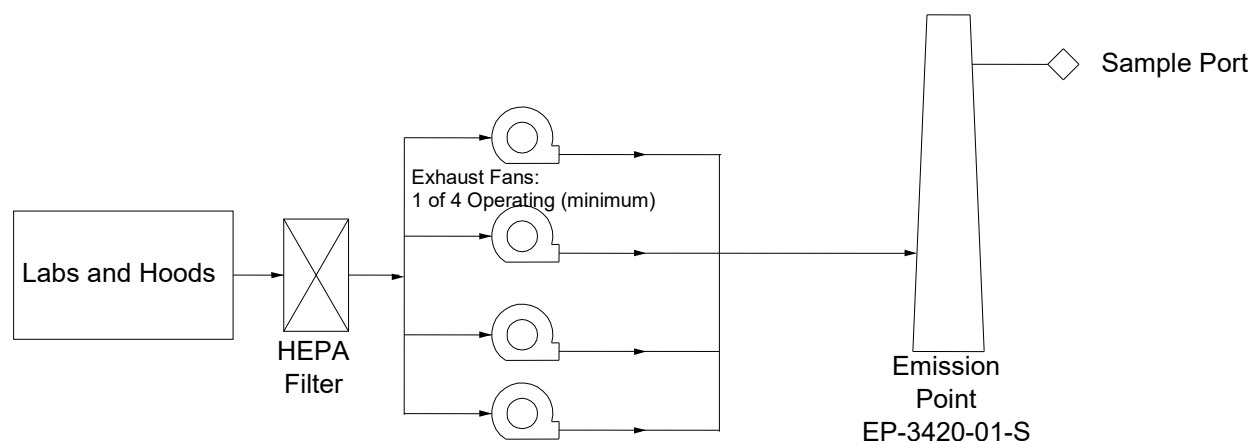

Figure D.4. 3420-01-S Building Effluent Pathway

Exhaust Unit Flow Rate

Exhaust flow rates are determined using data collected from the RAES system. An average annual flow rate is calculated and is reported in the PNNL Campus Annual Report. The average flow rate is reported in Table 1.5 and is used to calculate the effective release height in the same table. An annual verification check of the RAES system is performed using [EPRP-AIR-016](#). The following tables provide flow rate and temperature measurements.

¹ In October 2020, the remodeled stack velocity exhaust rate increased to approximately 68,000 cfm.

Table D.7. 3420-01-S Building Exhaust Unit Flow Rate (from traverse data and as reported in the PNNL-Richland Campus Annual Report)

Date Measured	Flow Rate (cfm)	PNNL Campus Annual Report Average Flow Rate (cfm)
05/23/16	51,200	47,200
05/19/17	57,000	50,870
05/04/18	57,600	50,830
05/31/19	56,800	51,900 ^(a)
04/09/20	55,900	52,460 ^(b)
2016-20 average ± st.dev	55,700 ± 2600	50,650 ± 2050

Data have been truncated to the last 5 completed calendar years.
Average and standard deviation determined from EPRP-AIR-016 traverse data and from annual reporting. Standard deviation determined with Excel STDEVA function of the indicated annual value.
(a) Corrected value provided in the following year's report.
(b) The flow rate after the 2020 remodel with additional fan is in the range of 65,000 to 70,000 cfm (and possibly up to 80,000 cfm).

Table D.8. 3420-01-S Building Exhaust Unit Temperature (from traverse data)

Date Measured	Temperature (°F)
05/23/16	69
05/19/17	74
05/04/18	82
05/31/19	77
04/09/20	67
2016-20 average ± st.dev	74 ± 6.1

Record Particulate Sample System Description

The record particulate sampling system for emission unit EP-3420-01-S is operated in conformance with 40 CFR 61, Subpart H (EPA 2002a), and ANSI/HPS N13.1–2011 requirements. See Stack Sampler Configuration Drawing H-3-312964.

A record particulate sampling system samples the exhaust from emission unit EP-3420-01-S in conformance with 40 CFR 61, Subpart H (EPA 2002a). A shrouded probe mounted in the center two-thirds of the exhaust stack conducts continuous sampling for particulates.

A stainless steel shrouded probe supplied by Air Monitor Corporation is used to extract the sample. The single-nozzle inlet has a 1.225-in. ID. The sample nozzle is tapered and feeds into a 1.125-in. ID transport line that is run on a horizontal plane across the stack. See vendor-supplied drawing for details: W68683AD.

The sample transport line is constructed of 1.12-in. ID stainless steel tubing. The line extends 0.49 in. outside of the duct and terminates in a heated cabinet containing the sample collection filter, flowmeters, and adjustment valves. The sample line temperature is maintained above that of the stack gas to prevent condensation from forming in the sample line.

Vacuum Air Sample System

A single Airtech Inc. regenerative pump located in the second floor equipment room supplies the vacuum to the sample system. This system is powered by normal power.

Sample Collection

A shrouded probe mounted in the center two-thirds of the exhaust stack conducts continuous sampling for particulates. The system is designed and constructed in accordance with ANSI/HPS N13.1–2011 (HPS 2011) and its components are calibrated annually. The radiological air emissions sampling operates under variable volume and temperature conditions. Membrane filters collect samples of particulate matter. The confirmatory demonstration of compliance is performed against previously proven testing data of similar design. Sampling system inspections are performed before initiating sampling event and daily (excluding holidays and weekends) during sample collection.

Battelle Drawings

Mechanical Roof Duct Plan
Mechanical MEP Section Stack Height
Plumbing Vacuum Air Diagram

Number

H-3-312934
H-3-312964
H-3-313069

Electronic access to these drawings is available.

Air Monitor Corp. Drawings

Flow & Sampler Probes General Arrangement

Number

W68683AD

Other drawings are provided by the vendor and are not available electronically at this time.

D.2.3 Emission Unit EP-3430-01-S: Ultratrace Analysis Building



Facility/Process Description

The 3430 Building provides ultratrace radio-analytical capabilities for nuclear forensics in support of critical national needs, such as international treaty verification. These capabilities include highly sensitive analytical systems, such as mass spectrometers, optical microscopes, and electron microscopes to provide isotopic analyses and ultra-low-level radionuclide detection in a wide variety of sample matrices. Work activities include research in ultra-trace and low-level detection and characterization of radionuclides that can be used for detecting the proliferation of weapons of mass destruction. Basic research includes focusing on innovative radiochemical separations and method development as well as new instrument development, providing analytical services results to national security clients.

Emission Unit Specifics

The design of the 3430 Building specifies that all HEPA filtered radiological areas exhaust through a single emission unit: EP-3430-01-S. Single-stage HEPA filters control radiological exhaust using one of two variable air flow exhaust fans operating at any one time. Operating characteristics are provided below.

Emission Unit ID	EP-3430-01-S	
Emission Sample Unit ID	ESP-3430-01-S	
Traverse Point ID	TP-3430-01-1	
Stack Height	13.5 m	(44.4 ft)
Stack Diameter	1.12 m	(3.67 ft)
Average Volumetric Flow Rate (5-yr average, 2016-20)	17.3 m ³ s ⁻¹	(35,500 cfm)
Exhaust Velocity	15.5 m s ⁻¹	(51.2 ft s ⁻¹)
Fan Rated Maximum (single fan)	13.7 m ³ s ⁻¹	(29,000 cfm)
Cross Sectional Area	0.99 m ²	(10.6 ft ²)
Average Stack Temperature (5-yr average, 2016-20)	21°C	(71°F)
Operating Temperature Range	18.3 – 25.6°C	(65 – 78°F)
Effective Stack Height	36.0 m	(118 ft)
HEPA Filter Design Efficiency	≥ 99.90%	
Latitude	46.352 North	
Longitude	119.278 West	

Exhaust Unit Control Technology

The following simplified drawing shows the effluent pathway and the installed control technology for the 3430 Building emission unit:

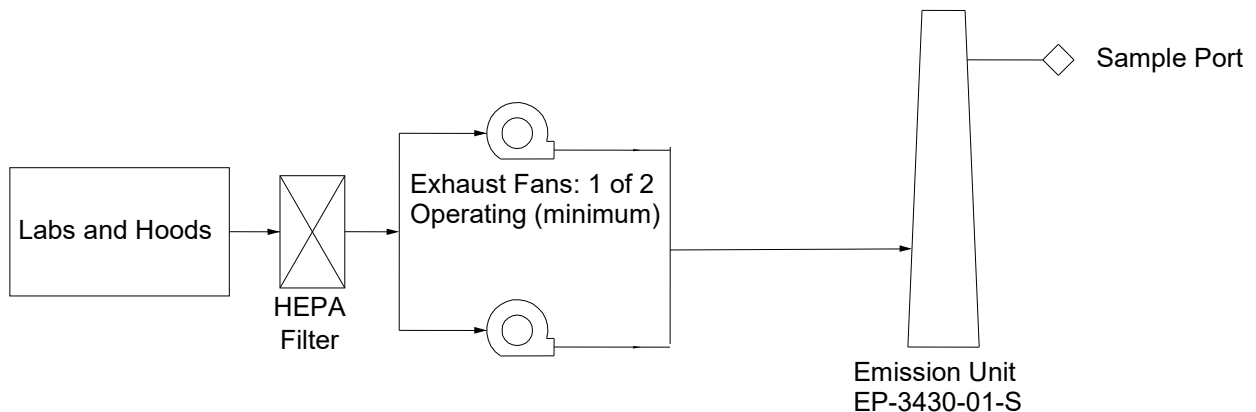

Figure D.5. 3430-01-S Building Effluent Pathway

Exhaust Unit Flow Rate

Exhaust flow rates are determined using data collected from the RAES system. An average annual flow rate is calculated and is reported in the PNNL Campus Annual Report. The average flow rate is reported in Table 1.5 and is used to calculate the effective release height in the same table. An annual verification check of the RAES system is performed using [EPRP-AIR-016](#). The following tables provide flow rate and temperature measurements.

Table D.9. 3430-01-S Building Exhaust Unit Flow Rate (from traverse data and as reported in the PNNL-Richland Campus Annual Report)

Date Measured	Flow Rate (cfm)	PNNL Campus Annual Report Flow Rate (cfm)
05/24/16	30,600	32,560
05/18/17	36,300	33,080
04/13/18	37,500	33,560
04/12/19	36,500	35,480
04/08/20	36,800	34,790
2016-20 average \pm st.dev	35,540 \pm 2800	33,900 \pm 1200

Data have been truncated to the last 5 completed calendar years.
Average and standard deviation determined from valid EPRP-AIR-016 traverse data and from annual reporting. Standard deviation determined with Excel STDEVA function of the indicated annual values.

Table D.10. 3430-01-S Building Exhaust Unit Temperature (from traverse data)

Date Measured	Temperature (°F)
05/24/16	70
05/18/17	73
04/13/18	74
04/12/19	74
04/08/20	62
2016-2020 average \pm st.dev	71 \pm 5.0

Record Particulate Sample System Description

The record particulate sampling system for emission unit EP-3430-01-S is operated in conformance with 40 CFR 61, Subpart H (EPA 2002a), and ANSI/HPS N13.1–2011 (HPS 2011) requirements. See Stack Sampler Configuration Drawing H-3-313813.

A record particulate sampling system samples the exhaust from emission unit EP-3430-01-S for radioactive particulates in conformance with 40 CFR 61, Subpart H (EPA 2002a). A shrouded probe mounted in the center two-thirds of the exhaust stack conducts continuous sampling for particulates.

A stainless steel shrouded probe supplied by Air Monitor Corporation is used to extract the sample. The single nozzle inlet has a 1.225-in. ID. The sample nozzle is tapered and feeds into a 1.125-in. ID transport line that is run on a horizontal plane across the stack. See vendor-supplied drawing for details: W68683AD.

The sample transport line is constructed of 1.12-in. ID stainless steel tubing. The line extends 0.49 in. outside of the duct and terminates in a heated cabinet containing the sample collection filter, flowmeters, and adjustment valves. The sample line temperature is maintained above that of the stack gas to prevent condensation from forming in the sample line.

Vacuum Air Sample System

A single Airtech Inc. regenerative pump located in the second floor equipment room supplies the vacuum to the sample system. This system is powered by normal power.

Sample Collection

A shrouded probe mounted in the center two-thirds of the exhaust stack conducts continuous sampling for particulates. The sampling system is designed and constructed in accordance with ANSI/HPS N13.1–2011 (HPS 2011). The radiological air emissions sampling operates under variable volume and temperature conditions. Membrane filters collect samples of particulate matter. The confirmatory demonstration of compliance is performed against previously proven testing data of similar design. The sampling system components are calibrated annually. Sampling system inspections are performed before initiating sampling event and daily (excluding holidays and weekends) during sample collection.

Battelle Drawings

Mechanical MEP Section Stack Height
Plumbing Vacuum Air Diagram

Number

H-3-313813
H-3-313885

Electronic access to these drawings is available.

Air Monitor Corp. Drawings

Flow & Sampler Probes General Arrangement

Number

W68683AD

Other drawings are provided by the vendor and are not available electronically at this time.

Appendix E

PNNL and PNNL-applicable Non-sampled (Stacks, Fugitive, and PIC-5) Emission Units

Appendix E: PNNL and PNNL-applicable Non-sampled (Stacks, Fugitive, and PIC-5) Emission Units

This appendix describes the non-sampled emission units operated by Pacific Northwest National Laboratory (PNNL), as well as those on the Hanford Site that may be applied by PNNL. These include stacks; fugitive, diffuse, or non-point source emissions; and emissions authorized as a group with little to no emission potential (e.g., potential impact category [PIC]-5 emission units). Section E.1 provides details for Hanford Site emission units. Section E.2 provides details for PNNL-Richland Campus emission units. Section E.3 provides details for the PNNL-Sequim Campus emission unit.

E.1 Hanford Site Non-Sampled Emission Units

A description of the non-sampled emission units for each Hanford Site PNNL authorization is provided. Applicable emission unit specifics including a photo, process description, and emission unit specifics are as follows:

- J-318,
- EP-331-09-S, and
- J-361
- 300 Area Soil Excavation Activities
- Sitewide – PTRAEU
- Sitewide – Vented Container Storage
- Sitewide – HEPA Filtered Vacuums

E.1.1 Emission Unit J-318: 318 Building, Radiological Calibrations Laboratory



Process Description

The 318 Building laboratory spaces may be used for research and development activities involving dispersible radioactive material. The laboratory provides technical services in internal dosimetry, external dosimetry, instrument calibration, repair and materials testing for protecting

the health of workers and the public, and liability protection for government and industrial customers. Additionally, workplace measurements are applied to research and development activities to better understand and determine occupational exposures. There is a direct support for environment, health, safety, and security systems for providing accurate information about the level of exposure and dose to the workers. It also stages and maintains equipment and performs team training for radiological assistance and response to radiological incidents.

Emission Unit Specifics

The 318 Building is a fugitive, non-point source of emissions on the Hanford Site. Radionuclides are tracked using the PNNL Radioactive Material Tracking system, and emissions are determined using 40 CFR 61, Appendix D calculations in lieu of monitoring.

Emission Unit ID	J-318
Building Height	Varies
Temperature	21 ± 4°C (70 ± 6°F)
Latitude	46.3656 North
Longitude	119.2781 West

E.1.2 Emission Unit EP-331-09-S: 331 Building, Life Sciences Laboratory North Wing



Process Description

The primary activity is the use of nuclear magnetic resonance instruments in the 331 Building EP-331-09-S ventilated air spaces for analysis of non-volatile solid and liquid samples containing radioisotopes. Additional research capabilities include actinide chemistry; the study

of interactions of chemicals and radionuclides with plants, animals, and microorganisms; and the fate of chemicals and radionuclides in the environment.

Emission Unit Specifics

The 331 Building EP-331-09-S emission unit is a non-sampled minor point source of emissions on the Hanford Site. Radionuclides are tracked using the PNNL Radioactive Material Tracking system, and emissions are determined using 40 CFR 61, Appendix D calculations in lieu of monitoring.

Emission Unit ID	EP-331-09-S
Approximate Stack Height	14 m (46 ft)
Approximate Stack Diameter	1 m (3.2 ft = 40 in.)
Estimated Volumetric Flow Rate	9.8 m ³ / s (20,700 cfm)
Estimated Exhaust Velocity	12.1 m/s (39.6 ft/s)
Nominal Stack Temperature	24°C (75°F)
Approximate Effective Stack Height	37.3 m (122 ft)
Latitude	46.3650 North
Longitude	119.2714 West

E.1.3 Emission Unit J-361: 361 Building, Modular Equipment Shelter



Process Description

The 361 Building Modular Equipment Shelter is a pre-cast concrete portable equipment shelter that is permanently located in the southwest corner of the 300 Area on the Hanford Site.

Sampling equipment samples atmospheric gases. Periodically, radioactive gases/materials are used to confirm the operability of the equipment and may include radioxenon and radon gases to evaluate atmospheric gases. Other small quantities of radioactive material may also be used at the building.

Emission Unit Specifics

The 361 Building is a fugitive, non-point source of emissions on the Hanford Site. Releases occur at the building after being routed through a sample system and collected in a sample archive bottle prior to release. Radionuclides are tracked using the PNNL Radioactive Material Tracking system. Emissions are determined using 40 CFR 61, Appendix D calculations in lieu of monitoring; additionally, radioactive gas releases are entered into the Rad Air Gas database for tracking and reporting purposes.

Emission Unit ID	J-361
Building Height	Approx. 3 m (approx. 10 ft)
Temperature	[ambient]
Latitude	46.3636 North
Longitude	119.2821 West

E.1.4 Emission Unit 443: 300 Area Soil Excavation Activities

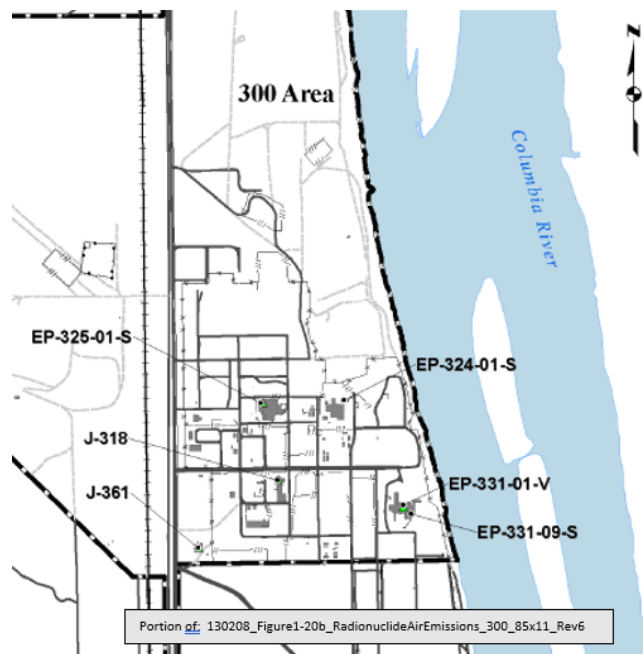

Figure source: Dyekman et al. 2021.

Process Description

The fugitive 300 Area Diffuse/Fugitive emission unit (EU ID 443) applies to 300-Area-wide soil excavation activities. Emissions result from radioactive materials emitted during excavation activities in the vicinity of 300 Area structures and facilities. Excavation activities are limited to

those in support of site stabilization, site infrastructure, and removing/isolating/blanking/routing/re-routing utilities; obtaining samples during 300 Area deactivation activities; and activities related to access for surveillance and maintenance, replacement-in-kind, and non-radiological equipment. Excavation activities may be done with machines or manual digging. Samples may be obtained by excavation or other coring or drilling methods.

Emission Unit Specifics

PNNL or any Hanford Site contractor may apply the 300 Area Diffuse/Fugitive emission unit (EU ID 443), which is a fugitive, non-point source of emissions on the Hanford Site. Legacy contamination exists in the soil or structures in the 300 Area and may be disturbed during excavation or facility maintenance activities. Excavation activities are tracked by the Hanford Site integrating contractor. Emissions are particulate in nature. Emissions are sampled by the network of ambient air monitoring stations in the vicinity of the 300 Area. These sampling stations are managed by the Hanford Site Environmental Surveillance Program.

Emission Unit ID	300 Area Soil Excavation Activities (EUID 443)
Building Height	N/A
Temperature	[ambient]
Latitude (approx.)	46.3656 North
Longitude (approx.)	119.2781 West

E.1.5 Emission Unit 447: Hanford Site Portable Temporary Radioactive Air Emission Unit (PTRAEU)

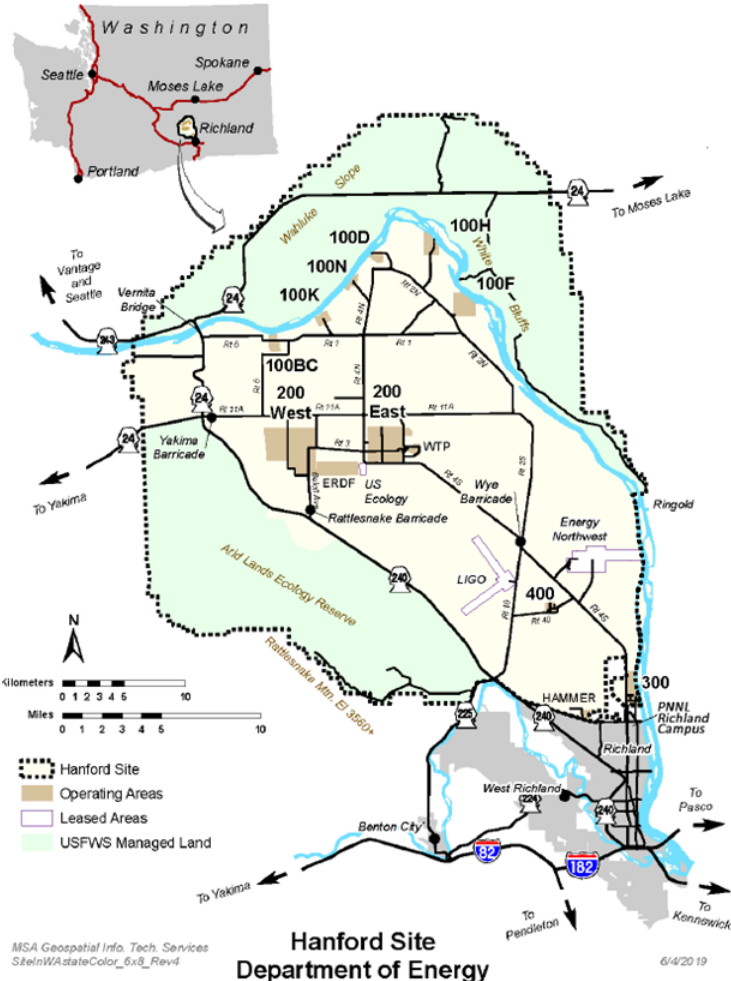

Figure source: Dyekman et al. 2021.



Process Description

The fugitive Portable/Temporary Radionuclide Airborne Emissions Units (PTRAEU) emission unit (EU ID 447) applies sitewide on the Hanford Site. PNNL-applications are generally within the 300 Area. Emissions result from using PTRAEU equipment that involves mobile filtration, sample preparation, screening and analysis units, and ventilation operations. Emissions result from ventilation air exhaust or use acquiring samples from contaminated soil or liquids from cribs, ditches, ponds, burial sites. An example of use at the Hanford Site includes contamination control during roof replacement activities.

The PTRAEU has either a HEPA or charcoal filtration unit. The unit(s) is portable and temporarily located for use. Three categories of PTRAEUs are identified:

- Type I with 1 HEPA filter – portable ventilation-filter unit for adding ventilation capacity with filtration,
- Type II with a HEPA and charcoal filter – mobile sample preparation unit for reducing the chance of unintentional cross-contamination of samples and improve occupation radiological safety; some Type II units are self-contained such that environmental condition (e.g., wind, precipitation, exhaust fumes) impacts are minimized, and
- Type III with a HEPA and charcoal filter – mobile screening and analysis unit for acquiring preliminary samples and screen samples requiring further analysis.

Emission Unit Specifics

PNNL or any Hanford Site contractor may apply the PTRAEU emission unit (EU ID 447), which is a fugitive, non-point source of emissions on the Hanford Site. PNNL uses an administrative log for tracking emissions; logs are periodically provided to the Hanford Site integrating contractor.

Emission Unit ID	PTRAEU (EUID 447)
Building Height	N/A
Temperature	[ambient]
Latitude (approx.)	46.3656 North
Longitude (approx.)	119.2781 West

E.1.6 Emission Unit 448: Hanford Site Vented Container Storage

<See E.1.5 for Hanford Site image>

Process Description

The fugitive Hanford Site Vented Container Storage Emissions Unit (EU ID 448) applies sitewide on the Hanford Site. PNNL applications are generally within the 300 Area. Vented containers are stored on the Hanford Site and are subject to surveillance and monitoring. The radioactive or mixed material in the containers may have been generated on or off the Hanford Site.

- Note: Vented containers associated with the 325 / Radiochemical Processing Laboratory (RPL) operations boundary are considered to be covered by the 325/RPL NOC approved process description.

Hanford Site vented containers are managed at several locations. Container vents are installed when there is a potential for non-radioactive gases (i.e., hydrogen) to be generated as a result of radiolysis. Most containers are drums, but other container types may meet the conditions of the emission unit. This emission unit establishes a categorical As Low As Reasonably Achievable Control Technology (ALARACT) demonstration and a categorical Best Available Radionuclide Control Technology (BARCT) for Hanford Site vented containers (up to 6667 vented container units). NucFil™ filter or equivalent are ALARACT and BARCT. Existing vent clips are accepted as ALARACT but are not usable upon repackaging.

Emissions are particulate (potentially) or tritium gas in nature. Emissions are sampled by the network of ambient air monitoring stations in the vicinity of the stored containers. These sampling stations are managed by the Hanford Site Environmental Surveillance Program.

Emission Unit Specifics

PNNL or any Hanford Site contractor may apply the Vented Container Storage emission unit (EU ID 448) which is a fugitive, non-point source of emissions on the Hanford Site. PNNL uses an administrative log for tracking emissions; logs are periodically provided to the Hanford Site integrating contractor.

Emission Unit ID	Vented Container Storage (EUID 448)
Building Height	N/A
Temperature	[ambient]
Latitude (approx.)	46.3656 North
Longitude (approx.)	119.2781 West

E.1.7 Emission Unit 455: Hanford Site HEPA Filtered Vacuums (HVU)

<See E.1.5 for Hanford Site image>

Process Description

The HEPA filtered vacuum radioactive air emission units (HVU) (EU ID 455) applies sitewide on the Hanford Site. PNNL applications are generally within the 300 Area. Essentially HEPA-filtered vacuum cleaners, the HVUs have varying designs and flow rates and are used to abate radionuclide emissions by providing filtered emissions when cleaning radioactively contaminated surfaces. Use of HVUs falls into three categories: 1) cleanup of radioactive removable surface contamination, 2) reduction of fixed near-surface contamination, and 3) vacuuming of near-surface contaminated soil. One PNNL application example is the vacuuming out of the 318 Building HVAC system outdoor coils.

Emission Unit Specifics

PNNL or any Hanford Site contractor may apply the HEPA filtered vacuum emission unit (EU ID 455), which is a fugitive, non-point source of emissions on the Hanford Site. PNNL uses an administrative log for tracking emissions; logs are periodically provided to the Hanford Site integrating contractor.

Emission Unit ID	HEPA Filtered Vacuums (EUID 455)
Building Height	N/A
Temperature	[ambient]
Latitude (approx.)	46.3656 North
Longitude (approx.)	119.2781 West

E.2 PNNL-Richland Campus Non-sampled Emission Units

A description of the non-sampled emission units for each PNNL-Richland Campus authorization is provided. Applicable emission unit specifics including a photo, process description, and emission unit specifics are as follows:

J-3425

EP-3420-02-S

EP-3430-02-S

PIC-5 Volumetrically Released Radiological Material

PIC-5 Non-Dispersible Radioactive Material

PIC-5 Facilities Restoration

PIC-5 Low-Level Sources

E.2.1 Emission Unit J-3425: 3425 Building, Ultra Low Background Counting Laboratory (Deep Lab)



Process Description

The 3425 Building is designed and constructed to mitigate cosmic-ray background radiation. The laboratory contains chemical laboratory space for metal electroplating; however, most activities are performed under clean-room conditions. Scientific capabilities include radiation physics, ultra-low radioactivity material development, fundamentals science, and ultra-low level counting.

Emission Unit Specifics

The 3425 Building is a fugitive, non-point source emissions on the PNNL-Richland Campus. Radionuclides are tracked using the PNNL Radioactive Material Tracking system, and emissions are determined using 40 CFR 61, Appendix D calculations in lieu of monitoring.

Emission Unit ID	J-3424
Building Height	Approx. 4.6 m (approx. 15.1 ft)
Temperature	22°C (72 ± 4°F)
Latitude	46.353 North
Longitude	119.276 West

E.2.2 Emission Unit EP-3420-02-S: 3420 Building, Radiation Detection Building



Process Description

The 3420 Building provides a wide variety of radionuclide measurement capabilities to conduct laboratory work activities associated with trace chemical and radionuclide detection, environmental assessment and remediation, treaty verifications, and proliferation detection and prevention. The capabilities used or under development would include state-of-the-art analytical chemistry, radiation physics, light detection, chromatography, scintillation materials, sorbent materials, and field-deployable forensics instrumentation. Applications range from fundamentals science to applied systems.

Emission Unit Specifics

The EP-3420-02-S, 3420 Building, emission unit is non-sampled point source on the PNNL-Richland Campus. Emission exhaust is controlled using three fans pulling from a single plenum, and each fan exhausts separately to the atmosphere. Radionuclides are tracked using the PNNL Radioactive Material Tracking system. Emissions are determined using 40 CFR 61, Appendix D calculations in lieu of monitoring; additionally, radioactive gas releases are entered into the Rad Air Gas database for tracking and reporting purposes.

Emission Unit ID	EP-3420-02-S
Stack Height	14 m (45 ft 11 in.)
Stack Discharge Diameter	1.1 m (44 in.)
Average Stack Exhaust Velocity	30.4 m s ⁻¹ (5,984 fpm)
Average Total Volumetric Flow Rate	28.9 m ³ s ⁻¹ (61,176 cfm)
Fan Rated Maximum	29.8 m ³ s ⁻¹ (63,400 scfm)
Average Stack Temperature	22°C (72°F)
Temperature Operating Range	18 – 24°C (65 – 78°F)
Effective Stack Height	35.6 m (117 ft)
Latitude	46.353 North
Longitude	119.276 West

E.2.3 Emission Unit EP-3430-02-S: 3430 Building, Ultratrace Analysis Building

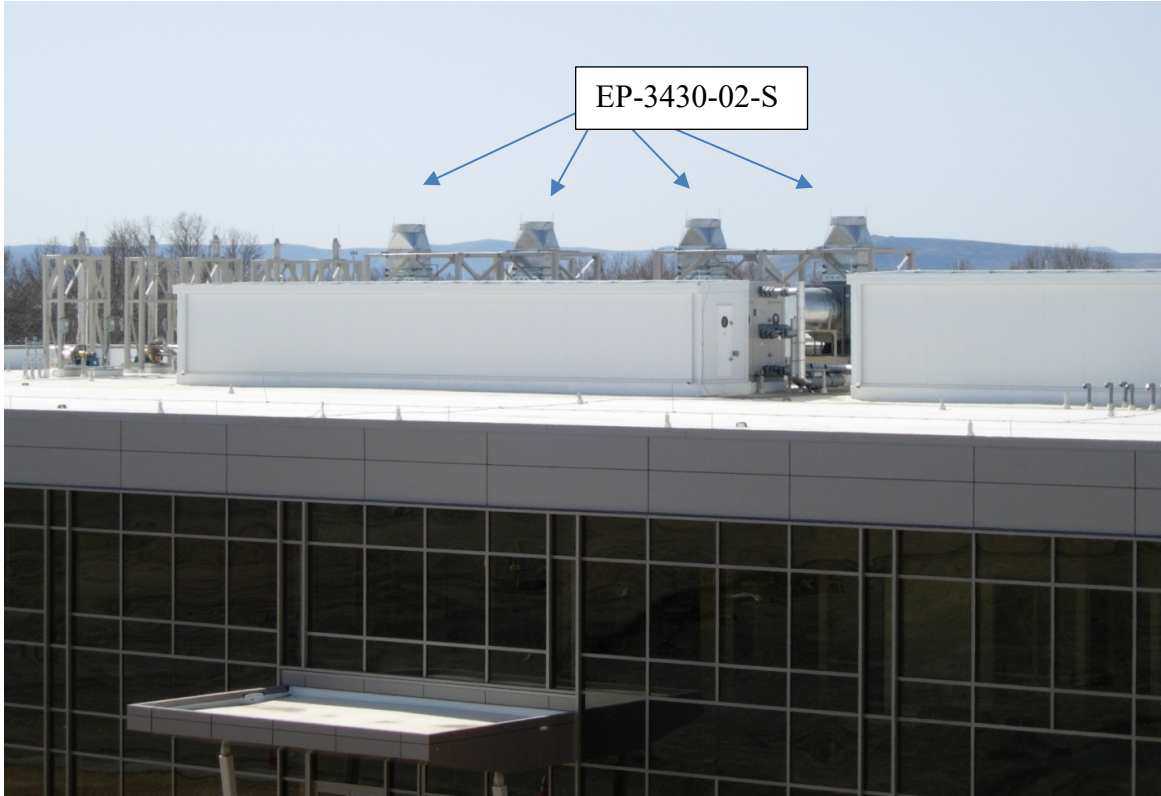

Process Description

The 3430 Building provides ultratrace radio-analytical capabilities for nuclear forensics in support of critical national needs and includes highly sensitive analytical systems such as mass spectrometers, optical microscopes, and electron microscopes to provide isotopic analyses and ultra-low-level radionuclide detection in a wide variety of sample matrices.

Emission Unit Specifics

The EP-3430-02-S, 3430 Building, emission unit is non-sampled point source on the PNNL-Richland Campus. Emission exhaust is controlled using four fans pulling from a single plenum, and each fan exhausts separately to the atmosphere. Radionuclides are tracked using the PNNL Radioactive Material Tracking system. Emissions are determined using 40 CFR 61, Appendix D calculations in lieu of monitoring; additionally, radioactive gas releases are entered into the Rad Air Gas database for tracking and reporting purposes.

Emission Unit ID	EP-3430-02-S	
Stack Height	14 m	(45 ft 11 in.)
Stack Discharge Diameter	1.0 m	(38 in.)
Average Stack Exhaust Velocity	40.0 m s ⁻¹	(7,868 fpm)
Average Total Volumetric Flow Rate	31.4 m ³ s ⁻¹	(66,549 cfm)
Fan Rated Maximum	36.4 m ³ s ⁻¹	(77,400 scfm)
Average Stack Temperature	22°C	(72°F)
Temperature Operating Range	18 – 24°C	(65 – 78°F)
Effective Stack Height	34.3 m	(112 ft)
Latitude	46.352 North	
Longitude	119.278 West	

E.2.4 Emission Unit PIC-5 Volumetrically Released Radiological Material: PNNL-Richland Campus



Process Description

The PIC-5 Volumetrically Released Radiological Material involves various types of radioactive material, including mixed activation products; mixed fission products; and naturally-occurring radioactive material, actinides, and a wide range of standards and tracer radionuclides. It includes liquid research samples and wastewater that has been released from radiological control using pre-approved volumetric release limits.

Emission Unit Specifics

The PIC-5 Volumetrically Released Radiological Material emission unit is a fugitive non-point source emission activity. PIC-5 activities have little to no emission potential and may be conducted site-wide on the PNNL-Richland Campus. Radionuclide emissions are conservatively set to the authorized annual permitted gross alpha and gross beta release values and can be confirmed via 40 CFR 61, Appendix D calculations in lieu of monitoring. Volumetrically released material is managed by Radiation Protection and tracked using the Volumetric Release Data Form Log as directed by RCP-4.2.05, "Releasing Liquid or Solid Material Potentially Contaminated in Volume from Radiological Control"; and is used by Effluent Management as a means for determining yearly emissions limits are not exceeded.

Release Height: N/A (fugitive emissions)

Latitude: 46.352 degrees North

Longitude: 119.275 degrees West

E.2.5 Emission Unit PIC-5 Non-dispersible Radioactive Material: PNNL-Richland Campus



Process Description

The PIC-5 Non-dispersible Radioactive Material uses radioactive material that has been determined to be non-dispersible and is used in research and development activities on the PNNL-Richland Campus. Research activities with such material may be mixed activation products; mixed fission products; and naturally-occurring radioactive materials, actinides, and a wide range of standards and tracer radionuclides.

Emission Unit Specifics

The PIC-5 Non-dispersible Radioactive Material emission unit is a fugitive non-point source emission activity. PIC-5 activities have little to no emission potential and may be conducted site-wide on the PNNL-Richland Campus. Radionuclide emissions are conservatively set to the permitted release values and can be confirmed via 40 CFR 61, Appendix D calculations in lieu of monitoring. Non-dispersible radioactive material is managed by Radiation Protection and tracked using the Nondispersible Radioactive Material Review Form – R3.1 in RCP-3.1.01, Radiological Work Planning. Records are generated by Radiation Protection and stored in their File Plan; they may be used by Effluent Management for determining yearly emissions limits are not exceeded.

Release Height: N/A (fugitive emissions)

Latitude: 46.352 degrees North

Longitude: 119.275 degrees West

E.2.6 Emission Unit PIC-5 Facilities Restoration: PNNL-Richland Campus



Process Description

The PIC-5 Facilities Restoration project includes contamination abatement activities associated with historical postings such as potentially internally contaminated equipment and ductwork, internally contaminated equipment and ductwork, and fixed contamination removal. Removal activities may include hoods, ductwork, fans, and HEPA filters. Some radiological sampling/surveys may be conducted.

Emission Unit Specifics

The PIC-5 Facilities Restoration emission unit is a fugitive non-point source emission activity. PIC-5 activities have little to no emission potential and may be conducted site-wide on the PNNL-Richland Campus. Standard radiation protection protocols (e.g., radiological surveys) are used to confirm low emissions.

Release Height: N/A (fugitive emissions)

Latitude: 46.346 degrees North

Longitude: 119.281 degrees West

E.2.7 Emission Unit PIC-5 Sources for Instrument/Operational Checks (Low-Level Sources): PNNL-Richland Campus



Process Description

The PIC-5 Low-Level Sources research activities include the development of field equipment used to detect and monitor radioactive materials in the environment that may result from activities involving nuclear material. The use and potential release of low-level radioactive sources is proposed to provide an operational check on the equipment.

Emission Unit Specifics

The PIC-5 Low-Level Sources emission unit is a fugitive non-point source emission activity. PIC-5 activities have little to no emission potential and may be conducted site-wide on the PNNL-Richland Campus. The PNNL Radioactive Air Gas Emissions website/database is used to track and maintain low emissions.

Release Height: N/A (fugitive emissions)

Latitude: 46.352 degrees North

Longitude: 119.275 degrees West

E.3 PNNL-Sequim Campus Non-sampled Emission Units

A description of the non-sampled emission units for the PNNL-Sequim Campus authorization is provided. Applicable emission unit specifics including a photo, process description, and emission unit specifics are as follows:

- J-MSL

E.3.1 Emission Unit J-MSL: PNNL-Sequim Campus



Process Description

The J-MSL emission unit covers the radioactive material emissions for all PNNL-Sequim Campus operations. The J-MSL emissions result from operations at all-purpose chemistry and biochemistry laboratories, and facilities for biological, chemical, and physical studies in which marine or aquatic environmental conditions need to be maintained. There is also a “cleanroom” for ultra-low level trace measurements in environmental media, an electronics shop, and diving operations and equipment storage.

Emission Unit Specifics

The J-MSL has multiple emission points that may or may not be actively ventilated or may be outdoors. Emissions from this non-point source are essentially fugitive in nature. Radionuclide emissions will be determined using 40 CFR 61, Appendix D calculations in lieu of monitoring. Radionuclide inventory at the Sequim Campus is tracked using the PNNL Radioactive Material Tracking system.

Emission Unit ID	J-MSL
Approximate (Fugitive) Release Height	Approx. 8 m (typical building height)
Latitude	48.077 North
Longitude	123.047 West

Appendix F

Deregistered/Transitioned/Closed Emission Units

Appendix F: Deregistered/Transitioned/Closed Emission Units

This appendix describes the buildings, exhaust units, control technologies, and sample extraction details for each sampled emission unit that has been deregistered/closed or transitioned out of Pacific Northwest National Laboratory (PNNL) operations within the last 5 years of the publication year of this document. Additionally, applicable stack sampler configuration drawings, figures, and photographs are provided for the following emission units:

- Hanford Site
 - none
- PNNL-Richland Campus
 - EP-3430-1606P-S – closed December 2018
 - EP-3430-1608P-S – closed December 2018
 - EP-3430-1610P-S – closed December 2018
 - EP-3430-1612P-S – closed December 2018
 - EP-3430-1614P-S – closed December 2018
 - EP-LSLII-01-V – closed August 2019
 - EP-LSLII-02-V – closed August 2019
 - EP-RTL-10-V – closed January 2019
 - EP-RTL-11-V – closed January 2019
 - J-RTL-530 – closed January 2019
 - J-RTL Complex – closed January 2019
- PNNL-Sequim Campus
 - MSL-1 – transitioned to J-MSL, January 2018
 - MSL-5 – transitioned to J-MSL, January 2018

The five 3430 perchloric acid hood stacks emissions were brought under the J-VRRM permit. The Life Sciences Laboratory II (LSL-II) laboratory ventilation system was remodeled to remove radiologically contaminated components; no dispersible radioactive material (other than PIC-5 materials) is now allowed in the building. The Research Technology Laboratory (RTL) Complex buildings have been decommissioned and demolished. No additional details are provided for the transitioned PNNL-Sequim Campus fugitive emission units: MSL-1 and MSL-5.

Note that information in this appendix is not updated past the deregistration/transition effective date – with the exception of the photo of the J-RTL Complex after closure.

F.1 Emission Unit EP-3430-1606P-S: 3430 Building, Ultra Trace Analysis Building



Process Description

The 3430 Building provides ultra-trace radio-analytical capabilities. Work with pre-approved volumetrically released quantities of radioactive liquids may be used in the perchloric acid hood EP-3430-1606P-S.

Emission Unit Specifics

The EP-3430-1606P-S, 3430 Building, emission unit is non-sampled point source on the PNNL-Richland Campus. Emission exhaust is controlled using a single fan that exhausts to the atmosphere. Radionuclides are tracked and associated with the volumetrically released radioactive material program. Emissions are determined using 40 CFR 61, Appendix D calculations in lieu of monitoring.

Emission Unit ID	EP-3430-1606P-S	
Stack Height	14.1 m	(46.2 ft)
Stack Discharge Diameter (Cone)	0.13 m	(5 in)
Stack Discharge Diameter (Duct)	0.20 m	(8 in)
Fan Rated Maximum	1.56 m ³ s ⁻¹	(3315 scfm)
Temperature Operating Range	18.3 – 25.6 C	(65 – 78 F)
Effective Stack Height	27.4 m	(89.9 ft)
Latitude	46.352 North	
Longitude	119.278 West	
Reference Drawings	H-3-313644 H-3-313814	

F.2 Emission Unit EP-3430-1608P-S: 3430 Building, Ultra Trace Analysis Building



Process Description

The 3430 Building provides ultra-trace radio-analytical capabilities. Work with pre-approved volumetrically released quantities of radioactive liquids may be used in the perchloric acid hood EP-3430-1608P-S.

Emission Unit Specifics

The EP-3430-1608P-S, 3430 Building, emission unit is non-sampled point source on the PNNL-Richland Campus. Emission exhaust is controlled using a single fan that exhausts to the atmosphere. Radionuclides are tracked and associated with the volumetrically released radioactive material program. Emissions are determined using 40 CFR 61, Appendix D calculations in lieu of monitoring.

Emission Unit ID	EP-3430-1608P-S	
Stack Height	14.1 m	(46.2 ft)
Stack Discharge Diameter (Cone)	0.13 m	(5 in)
Stack Discharge Diameter (Duct)	0.20 m	(8 in)
Fan Rated Maximum	1.56 m ³ s ⁻¹	(3315 scfm)
Temperature Operating Range	18.3 – 25.6 C	(65 – 78 F)
Effective Stack Height	27.4 m	(89.9 ft)
Latitude	46.352 North	
Longitude	119.278 West	
Reference Drawings	H-3-313644 H-3-313814	

F.3 Emission Unit EP-3430-1610P-S: 3430 Building, Ultra Trace Analysis Building



Process Description

The 3430 Building provides ultra-trace radio-analytical capabilities. Work with pre-approved volumetrically released quantities of radioactive liquids may be used in the perchloric acid hood EP-3430-1610P-S.

Emission Unit Specifics

The EP-3430-1610P-S, 3430 Building, emission unit is non-sampled point source on the PNNL-Richland Campus. Emission exhaust is controlled using a single fan that exhausts to the atmosphere. Radionuclides are tracked and associated with the volumetrically released radioactive material program. Emissions are determined using 40 CFR 61, Appendix D calculations in lieu of monitoring.

Emission Unit ID	EP-3430-1610P-S	
Stack Height	14.1 m	(46.2 ft)
Stack Discharge Diameter (Cone)	0.13 m	(5 in)
Stack Discharge Diameter (Duct)	0.20 m	(8 in)
Fan Rated Maximum	1.56 m ³ s ⁻¹	(3315 scfm)
Temperature Operating Range	18.3 – 25.6 C	(65 – 78 F)
Effective Stack Height	27.4 m	(89.9 ft)
Latitude	46.352 North	
Longitude	119.278 West	
Reference Drawings	H-3-313644 H-3-313814	

F.4 Emission Unit EP-3430-1612P-S: 3430 Building, Ultra Trace Analysis Building



Process Description

The 3430 Building provides ultra-trace radio-analytical capabilities. Work with pre-approved volumetrically released quantities of radioactive liquids may be used in the perchloric acid hood EP-3430-1612P-S.

Emission Unit Specifics

The EP-3430-1612P-S, 3430 Building, emission unit is non-sampled point source on the PNNL-Richland Campus. Emission exhaust is controlled using a single fan that exhausts to the atmosphere. Radionuclides are tracked and associated with the volumetrically released radioactive material program. Emissions are determined using 40 CFR 61, Appendix D calculations in lieu of monitoring.

Emission Unit ID	EP-3430-1612P-S	
Stack Height	14.1 m	(46.2 ft)
Stack Discharge Diameter (Cone)	0.13 m	(5 in)
Stack Discharge Diameter (Duct)	0.20 m	(8 in)
Fan Rated Maximum	1.56 m ³ s ⁻¹	(3315 scfm)
Temperature Operating Range	18.3 – 25.6 C	(65 – 78 F)
Effective Stack Height	27.4 m	(89.9 ft)
Latitude	46.352 North	
Longitude	119.278 West	
Reference Drawings	H-3-313644	
	H-3-313814	

F.5 Emission Unit EP-3430-1614P-S: 3430 Building, Ultra Trace Analysis Building



Process Description

The 3430 Building provides ultra-trace radio-analytical capabilities. Work with pre-approved volumetrically released quantities of radioactive liquids may be used in the perchloric acid hood EP-3430-1614P-S.

Emission Unit Specifics

The EP-3430-1614P-S, 3430 Building, emission unit is non-sampled point source on the PNNL-Richland Campus. Emission exhaust is controlled using a single fan that exhausts to the atmosphere. Radionuclides are tracked and associated with the volumetrically released radioactive material program. Emissions are determined using 40 CFR 61, Appendix D calculations in lieu of monitoring.

Emission Unit ID	EP-3430-1614P-S	
Stack Height	14.1 m	(46.2 ft)
Stack Discharge Diameter (Cone)	0.13 m	(5 in)
Stack Discharge Diameter (Duct)	0.20 m	(8 in)
Fan Rated Maximum	$1.56 \text{ m}^3 \text{ s}^{-1}$	(3315 scfm)
Temperature Operating Range	18.3 – 25.6 C	(65 – 78 F)
Effective Stack Height	27.4 m	(89.9 ft)
Latitude	46.352 North	
Longitude	119.278 West	
Reference Drawings	H-3-313644 H-3-313814	

F.6 Emission Unit EP-LSLII-01-V: Life Sciences Laboratory II



Process Description

The LSL-II provides capabilities for [*sic*] fundamental sciences, environmental technology, and toxicology. Activities are presently limited to sealed radioactive sources; radioactive material hold-up in the ductwork has been removed and high-efficiency particulate air (HEPA) filters are no longer required.

Emission Unit Specifics

The EP-LSLII-01-V emission unit is non-sampled point source on the PNNL-Richland Campus. Emission exhaust is controlled using four fans pulling from a single plenum, and each fan exhausts separately to the atmosphere. Radionuclides are tracked using the PNNL Radioactive Material Tracking system. Emissions are determined using 40 CFR 61, Appendix D calculations in lieu of monitoring.

Emission Unit ID	EP-3430-1614P-S	
Approximate Stack Height	4.7 m	(15.5 ft)
Approximate Stack Diameter	2.23 m	(87.75 in)
Estimated Volumetric Flow Rate (past average)	29.45 m ³ s ⁻¹	(62400 ± 620 cfm)
Average Stack Temperature	25 C	(77 F ± 2.5%)
Effective Stack Height	21.2 m	(69.4 ft)
Latitude	46.346 North	
Longitude	119.277 West	

F.7 Emission Unit EP-LSLII-02-V: Life Sciences Laboratory II



Process Description

The LSL-II provides capabilities for [*sic*] fundamental sciences, environmental technology, toxicology, biology, and vivarium spaces. Activities are presently limited to sealed radioactive sources; radioactive material hold-up in the ductwork has been removed and HEPA filters are no longer required.

Emission Unit Specifics

The EP-LSLII-01-V emission unit is non-sampled point source on the PNNL-Richland Campus. Emission exhaust is controlled using four fans pulling from a single plenum, and each fan exhausts separately to the atmosphere. Radionuclides are tracked using the PNNL Radioactive Material Tracking system. Emissions are determined using 40 CFR 61, Appendix D calculations in lieu of monitoring.

Emission Unit ID	EP-LSLII-01-V
Approximate Stack Height	7.4 m (24 ft 4.5 in.)
Approximate Stack Diameter	3.8 m (150.6 in)
Estimated Volumetric Flow Rate (past average)	9.94 m ³ s ⁻¹ (21,050 ± 2310 cfm)
Average Stack Temperature	25 C (77 F ± 2.5%)
Effective Stack Height	17.9 m (58.6 ft)
Latitude	46.352 North
Longitude	119.278 West

F.8 Emission Unit EP-RTL-10-V: Research Technology Laboratory



Emission Unit ID: EP-RTL-10-V
Emission Sample Unit ID: ESP-RTL-10-D
Traverse Point ID: TP-RTL-10-1

The RTL-520 Building is located in the Richland North Complex on the corner of 3rd Street and George Washington Way.

Google Maps Coordinates: Latitude: 46.337 degrees; Longitude: -119.274 degrees

Facility/Process Description

The RTL-520 Building and associated support buildings provide laboratory, office, and storage space in support of research and development (R&D) activities. The building currently houses staff from three directorates: Environmental Technology (ETD), Energy Science and Technology (ESTD), and Fundamental Science (FSD).

ETD research includes chemical toxicology, health physics, dosimetry, radiological engineering, atmospheric science and modeling, health risk assessment, and soil and groundwater contamination. ETD develops comprehensive environmental monitoring programs, and conducts

studies on various cleaning processes and using supporting analytical equipment to define progress.

The ESTD conducts R&D in coatings and coating technologies including polymer web coatings, sputtering coatings, large-optics coatings, e-beam evaporation coatings, and electospark coatings. Other ESTD capabilities are hydrothermal powder processing and microfabrication, which includes laser micromachining, electrochemical machining, and electrodeposition.

The FSD performs original research directed at understanding reactions that occur at the solid-liquid interface of geologic materials. These include interfacial reactions controlling contaminant concentrations in soils and groundwater, linked geochemical-microbiological processes such as electron transfer reactions, and isotope geochemistry. FSD also develops advanced selective laser ionization methods for detecting metal and inorganic materials at ultra-trace levels. Transition from sampled emissions to inventory-based methods occurred in August 2014. The Washington State Department of Health (WDOH) requires the disposal of HEPA filters by September 1, 2019, which was met by CH2M Hill Plateau Remediation Company during the RTL Complex demolition activities on January 16, 2018.

Exhaust Unit Description

EP-RTL-10-V is centrally located on the east end of the RTL-520 Building roof. All exhaust gas passes through at least one HEPA filter before discharge to the environment. The discharge point measures 26 ft, 0.5 in. above the existing ground-level grade. The duct is 31.9 in. in diameter and has a cross-sectional area of 5.6 ft².

Exhaust Unit Control Technology

The following simplified drawing shows the effluent pathway and the installed control technology for the RTL-520, EP-RTL-10-V, emission unit:

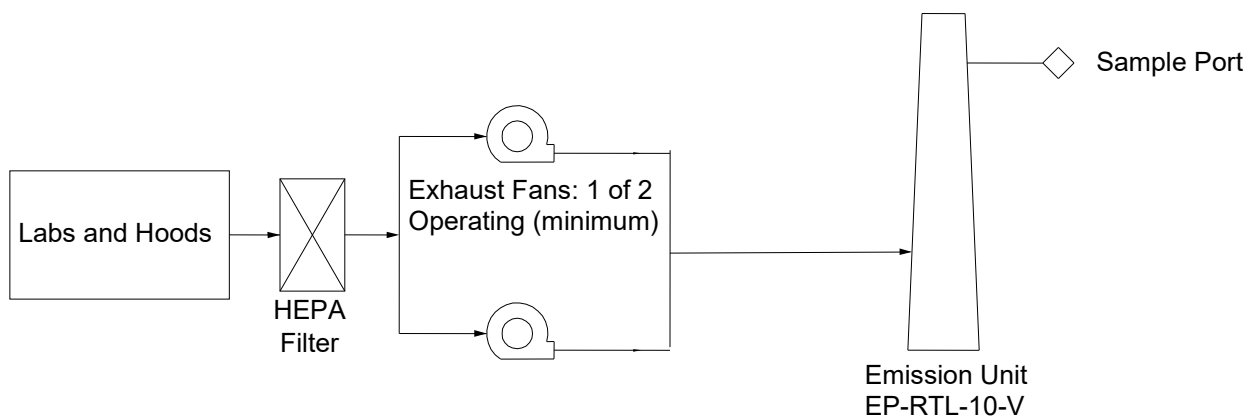

Figure F.1. RTL-10-V Effluent Pathway

Exhaust Unit Flow Rate and Temperature

Exhaust flow rates and temperature are determined annually using EM procedure [EPRP-AIR-016](#), which was developed based on the requirements in 40 CFR 60, Appendix A, Method 2 (EPA 2014). The following tables provide historical flow rate and temperature measurements:

Table F.1. RTL-10-V Exhaust Unit Flow Rate

Date Measured	Flow Rate (cfm)
04/12/00	14,941
04/19/01	14,000
04/05/02	15,600
04/11/03	14,800
04/16/04	14,300
04/12/05	13,300
04/28/06	13,600
04/19/07	13,400
04/10/08	13,700
04/15/09	13,700
04/27/10	13,300
04/07/11	13,700
04/19/12	14,400
04/08/13	14,000
04/28/14	13,900

Table F.2. RTL-10-V Exhaust Unit Temperature

Date Measured	Average Temperature (°F)
04/28/06	83
04/19/07	76
04/10/08	76
04/15/09	78
04/27/10	74
04/07/11	77
04/19/12	73
04/08/13	72
04/28/14	78

Record Particulate Sample System Description

The record particulate sampling system for emission unit EP-RTL-10-V is operated in conformance with ANSI N13.1–1969 (ANSI 1970) requirements. See Stack Sampler Configuration Drawing R-M-2004-1.

The record sample probe is positioned in the horizontal duct 23 ft, 11.4 in. (9.01 equivalent diameters) downstream of the nearest flow disturbance and 5 ft, 5.38 in. (2.05 equivalent diameters) upstream from the nearest flow disturbance. The sample extraction point position meets the 8:2 (downstream:upstream) duct-diameter placement recommendation from ANSI N13.1–1969 (ANSI 1970).

A stainless steel five-nozzle probe manufactured by Air Monitor Corporation is used to extract the sample from the duct. Each nozzle inlet has a 0.185-in. ID. The five sample nozzles are tapered and feed into a common 1.12-in. ID manifold that extends horizontally across the center of the duct. See vendor-supplied drawings for details: W36670AA, W36670BA, W36670BB, W36670BC, and W36670BD.

The sample transport line is constructed of 1.12-in. ID stainless steel tubing. The sample transport line extends 10 in. outside of the duct and terminates in a cabinet containing the collection filter, rotameter, and sample flow rate adjustment valve. The sample line upstream of the collector is insulated, heat traced, and electrically grounded. The sample line temperature is maintained above that of the stack gas to prevent condensation from forming in the sample line.

Vacuum Air Sample System

Stack emission samples are withdrawn from the stack and through the sample system by means of the building vacuum air sampling system located in East Service Corridor of the RTL-520 Building. This system has redundant carbon vane vacuum pumps that are powered by normal and emergency power.

Sample Collection

Particulate samples will be collected using an isokinetic sampling probe mounted in the exhaust dust in accordance with ANSI N13.1–1969 (ANSI 1970). Components are calibrated annually. Inspections of the sampling system are performed prior to initiating a sampling event and every day (excluding holidays and weekends) during sample collection.

Battelle Drawings

	<u>Number</u>
Mechanical Exhaust Fan Demolition Plan; Rev. 0	R-M-1947-1
Mechanical Exhaust Fan Plan; Rev. 2	R-M-1947-2
Mechanical Exhaust Fan Section and Details; Rev. 0	R-M-1947-3
Stack Sampler Configuration EP-RTL-10-V; Rev. 1	R-M-2004-1
Air Sample Station Instrument Cabinet Assembly; Rev. 8	H-3-70282-1
Stack Sample Filter Holder Inlet; Rev. 1	H-3-70447-1
Stack Sample Filter Holder Outlet; Rev. 0	H-3-70570-1

Electronic access to these drawings is available.

Air Monitor Corporation Drawings

	<u>Number</u>
SAMPLR–probe Threaded Nozzle; Rev. 0	W36670AA
SAMPLR–probe Top Assembly; Rev. 1	W36670BA
SAMPLR–probe Sample Manifold; Rev. 0	W36670BB
SAMPLR–probe Mounting Plate & Gasket; Rev. 1	W36670BC
SAMPLR–probe Radiused End Plug; Rev. 0	W36670BD

Other drawings are vendor provided and not electronically available at this time.

F.9 Emission Unit EP-RTL-11-V: Research Technology Laboratory



Emission Unit ID: EP-RTL-11-V
Emission Sample Unit ID: ESP-RTL-11-D
Traverse Point ID: TP-RTL-11-1

The RTL-520 Building is located in the Richland North Complex on the corner of 3rd Street and George Washington Way.

Google Maps Coordinates: Latitude: 46.337 degrees; Longitude: -119.275 degrees

Facility/Process Description

The RTL-520 Building and associated support buildings provide laboratory, office, and storage space in support of R&D activities. The building currently houses staff from three directorates: ETD, ESTD, and FSD.

ETD research includes chemical toxicology, health physics, dosimetry, radiological engineering, atmospheric science and modeling, health risk assessment, and soil and groundwater contamination. ETD develops comprehensive environmental monitoring programs, and conducts studies on various cleaning processes and using supporting analytical equipment to define progress.

The ESTD conducts R&D in coatings and coating technologies including polymer web coatings, sputtering coatings, large-optics coatings, e-beam evaporation coatings, and electospark coatings. Other ESTD capabilities are hydrothermal powder processing and microfabrication, which includes laser micromachining, electrochemical machining, and electrodeposition.

The FSD performs original research directed at understanding reactions that occur at the solid-liquid interface of geologic materials. These include interfacial reactions controlling contaminant concentrations in soils and groundwater, linked geochemical-microbiological processes such as electron transfer reactions, and isotope geochemistry. FSD also develops advanced selective laser ionization methods for detecting metal and inorganic materials at ultra-trace levels. Transition from sampled emissions to inventory-based methods occurred in August 2014. WDOH requires the disposal of HEPA filters by September 1, 2019, which was met by CH2M Hill Plateau Remediation Company during the RTL Complex demolition activities on January 16, 2018.

Exhaust Unit Description

EP-RTL-10-V is centrally located on the east end of the RTL-520 Building roof. All exhaust gas passes through at least one HEPA filter before discharge to the environment. The discharge point measures 26 ft, 0.5 in. above the existing ground-level grade. The duct is 31.9 in. in diameter and has a cross-sectional area of 5.6 ft².

Exhaust Unit Control Technology

The following simplified drawing shows the effluent pathway and the installed control technology for the RTL-520, EP-RTL-11-V, emission unit:

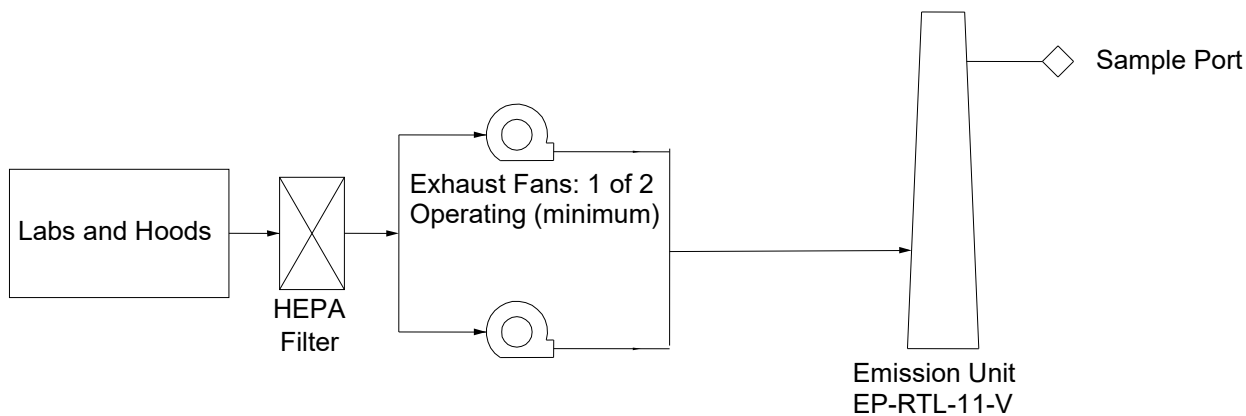

Figure F.2. RTL-11-V Effluent Pathway

Exhaust Unit Flow Rate and Temperature

Exhaust flow rates and temperature are determined annually using EM procedure [EPRP-AIR-016](#), which was developed based on the requirements in 40 CFR 60, Appendix A, Method 2 (EPA 2014). The following tables provide historical flow rate and temperature measurements:

Table F.3. RTL-11-V Exhaust Unit Flow Rate

Date Measured	Flow Rate (cfm)
04/12/00	17,643
04/19/01	16,900
04/05/02	17,400
04/11/03	16,100
04/16/04	17,100
04/12/05	17,800
04/28/06	17,500
04/19/07	17,500
04/10/08	17,300
04/15/09	17,500
04/27/10	19,500
04/07/11	20,000
04/19/12	19,600
4/8/2013	18,900
04/28/14	18,900

Table F.4. RTL-11-V Exhaust Unit Temperature

Date Measured	Average Temperature (°F)
04/28/06	80
04/19/07	76
04/10/08	78
04/15/09	80
04/27/10	79
04/07/11	80
04/19/12	78
04/08/13	75
04/28/14	77

Record Particulate Sample System Description

The record particulate sampling system for emission unit EP-RTL-11-V is operated in conformance with ANSI N13.1–1969 (ANSI 1970) requirements. See Stack Sampler Configuration Drawing R-M-2004-2.

The record sample probe is positioned in the horizontal duct 22 ft, 11.6 in. (8.64 equivalent diameters) downstream of the nearest flow disturbance and 5 ft, 5.38 in. (2.05 equivalent diameters) upstream from the nearest flow disturbance. The sample extraction point position meets the 8:2 (downstream:upstream) duct-diameter placement recommendation from ANSI N13.1–1969 (ANSI 1970).

A stainless steel five-nozzle probe manufactured by Air Monitor Corporation is used to extract the sample from the duct. Each nozzle inlet has a 0.185-in. ID. The five sample nozzles are tapered and feed into a common 1.12-in. ID manifold that extends horizontally across the center of the duct. See vendor-supplied drawings for details: W36670AA, W36670BA, W36670BB, W36670BC, and W36670BD.

The sample transport line is constructed of 1.12-in. ID stainless steel tubing. The sample transport line extends 8.5 in. outside the duct and terminates in a cabinet containing the collection filter, rotameter, and sample flow rate adjustment valve. The sample line upstream of the collector is insulated, heat traced, and electrically grounded. The sample line temperature is maintained above that of the stack gas to prevent condensation from forming in the sample line.

Vacuum Air Sample System

Stack emission samples are withdrawn from the stack and through the sample system by means of the building vacuum air sampling system located in East Service Corridor of the RTL-520 Building. This system has redundant carbon vane vacuum pumps that are powered by normal and emergency power.

Sample Collection

Particulate samples will be collected using an isokinetic sampling probe mounted in the exhaust duct in accordance with ANSI N13.1–1969 (ANSI 1970). Components are calibrated annually. Inspections of the sampling system are performed prior to initiating a sampling event and every day (excluding holidays and weekends) during sample collection.

Battelle Drawings

	<u>Number</u>
Mechanical Exhaust Fan Demolition Plan; Rev.0	R-M-1967-1
Mechanical Exhaust Fan Plan; Rev.2	R-M-1967-2
Mechanical Exhaust Fan Section and Details; Rev.0	R-M-1967-3
Stack Sampler Configuration EP-RTL-11-V; Rev.1	R-M-2004-2
Air Sample Station Instrument Cabinet Assembly; Rev.8	H-3-70282-1
Stack Sample Filter Holder Inlet; Rev.1	H-3-70447-1
Stack Sample Filter Holder Outlet; Rev.0	H-3-70570-1

Electronic access to these drawings is available.

Air Monitor Corporation Drawings

	<u>Number</u>
SAMPLR–probe Threaded Nozzle; Rev.0	W36670AA
SAMPLR–probe Top Assembly; Rev. 1	W36670BA
SAMPLR–probe Sample Manifold; Rev. 0	W36670BB
SAMPLR–probe Mounting Plate & Gasket; Rev. 1	W36670BC
SAMPLR–probe RADIUSed End Plug; Rev. 0	W36670BD

Other drawings are vendor provided and not electronically available at this time.

F.10 Emission Unit J-RTL530



Process Description

The RTL-530 Building is a fugitive emissions unit. There is no active ventilation system at the building. It is a permanently installed brick building with 145 square feet of space, located at the west side of the RTL-520 Building and the area used for low-level radiological material storage area, and waste storage and holding.

Emission Unit Specifics

The emission unit specifications are identified below. The height of release corresponds to the height of the building which is approximately 3 m (about 10 ft).

Emission Unit ID	J-RTL530
Approximate Stack Height	N/A
Approximate Stack Diameter	N/A (fugitive emissions)
Estimated Volumetric Flow Rate (past average)	N/A
Average Stack Temperature	N/A
Effective Stack Height	3 m (10 ft)
Latitude	46.337 North
Longitude	119.275 West

F.11 Emission Unit J-RTL Complex: Research Technology Laboratory Complex



Process Description

The RTL Complex conducted research and development for environmental technology, energy science and technology, and fundamental science. The complex consisted of several buildings slated for contamination abatement, demolition, and removal activities including the historical emissions units: EP-RTL-10-V, EP-RTL-11-V, and J-RTL530. There are no remaining RTL structures; ongoing soil backfill is in progress.



Emission Unit Specifics

The RTL Complex emission unit is a fugitive emission source on the PNNL-Richland Campus. While only annual administrative review is required to confirm low levels of radioactive material, demolition activities resulting in potential emissions include periodic confirmatory measurements consisting of radiological surveys to confirm the actual emissions.

Emission exhaust is controlled using four fans pulling from a single plenum, and each fan exhausts separately to the atmosphere. Radionuclides are tracked using the PNNL Radioactive Material Tracking system. Emissions are determined using 40 CFR 61, Appendix D calculations in lieu of monitoring.

Emission Unit ID	J-RTL-Complex
Approximate (Fugitive) Release Height	Approx. 3 m (approx. 10 ft.)
Latitude	46.337 North
Longitude	119.274 West



**Pacific
Northwest**
NATIONAL LABORATORY

www.pnnl.gov

902 Battelle Boulevard
P.O. Box 999
Richland, WA 99352
1-888-375-PNNL (7665)

U.S. DEPARTMENT OF
ENERGY