

CONF-980921--

# SNS TARGET TEST FACILITY FOR REMOTE HANDLING DESIGN AND VERIFICATION\*

RECEIVED  
AUG 11 1998  
OSTI

Philip T. Spampinato, Van B. Graves, and Steven L. Schrock  
Oak Ridge National Laboratory  
Robotics and Process Systems Division  
P.O. Box 2008  
Oak Ridge, TN 37831-6304  
(423)574-7153

"The submitted manuscript has been authored by a contractor of the U.S. Government under contract No. DE-AC05-96OR22464. Accordingly, the U.S. Government retains a nonexclusive, royalty-free license to publish or reproduce the published form of this contribution, or allow others to do so, for U.S. Government purposes."

To be published in the Proceedings of Nuclear Applications of Accelerator Technology

**MASTER** *jos*

**DISTRIBUTION OF THIS DOCUMENT IS UNLIMITED**

\* This research was sponsored by the Office of Fusion Energy Sciences, U.S. Department of Energy, under contract DE-AC05-96OR22464 with Oak Ridge National Laboratory, managed by Lockheed Martin Energy Research Corporation.

## DISCLAIMER

This report was prepared as an account of work sponsored by an agency of the United States Government. Neither the United States Government nor any agency thereof, nor any of their employees, make any warranty, express or implied, or assumes any legal liability or responsibility for the accuracy, completeness, or usefulness of any information, apparatus, product, or process disclosed, or represents that its use would not infringe privately owned rights. Reference herein to any specific commercial product, process, or service by trade name, trademark, manufacturer, or otherwise does not necessarily constitute or imply its endorsement, recommendation, or favoring by the United States Government or any agency thereof. The views and opinions of authors expressed herein do not necessarily state or reflect those of the United States Government or any agency thereof.

## **DISCLAIMER**

**Portions of this document may be illegible in electronic image products. Images are produced from the best available original document.**

# SNS TARGET TEST FACILITY FOR REMOTE HANDLING DESIGN AND VERIFICATION\*

Philip T. Spampinato, Van B. Graves, Steven L. Schrock  
Oak Ridge National Laboratory  
P.O. Box 2008  
Oak Ridge, TN 37831-6304  
(423)574-7153

## ABSTRACT

The Target Test Facility will be a full-scale prototype of the Spallation Neutron Source Target Station. It will be used to demonstrate remote handling operations on various components of the mercury flow loop and for thermal/hydraulic testing. This paper describes the remote handling aspects of the Target Test Facility. Since the facility will contain approximately 1 cubic meter of mercury for the thermal/hydraulic tests, an enclosure will also be constructed that matches the actual Target Test Cell.

## I. INTRODUCTION

The Target Test Facility (TTF) will be a full-scale prototype of the Spallation Neutron Source (SNS) Target Station<sup>1</sup> with two testing objectives. It will be used to demonstrate remote handling (RH) operations on the components that make up the mercury target flow loop system, and for thermal/hydraulic testing of the mercury flow loop. This paper describes the remote handling aspects of the TTF.

## II. BACKGROUND

Early in the SNS project, it was recognized that R&D would be required to address issues dealing with thermal/hydraulics, and issues dealing with remote handling and component maintenance. It was also recognized that both of these would require the use of full-scale systems, hence two large facilities would be needed. Several trade studies were done that indicated significant cost savings could be achieved by combining these two functions into one facility, and it was also determined that compatible schedules for the two test

programs could be achieved. Also, additional SNS project savings could be made possible by using an existing high bay facility that already had remote handling equipment.

The Target Station in the TTF is a replica of the actual mercury flow loop<sup>2</sup> and contains components that include a centrifugal pump, heat exchanger, storage tank, the "shielded" target module, numerous pipes up to 5 in. diameter, pipe couplings, valves, and various diagnostics and sensors. Since there will be no radioactivity in the TTF, shielding will be simulated in geometry and size only. Figure 1 shows the mercury target flow loop equipment. The remote handling tests will be used to verify that optimal arrangements have been designed for the various components, and that all components can be replaced within the time allotted for maintenance operations.

## III. ENCLOSURE

The presence of mercury for thermal/hydraulic testing requires that the flow loop must be operated in an enclosure, which provides TTF containment. The enclosure is designed to simulate the dimensions of the actual Target Test Cell. The enclosure will be constructed in two sections or rooms, one to house the process equipment, and the other to house the target module. A common wall will divide the two rooms. Mercury will be drained from the flow loop into the TTF storage tank before commencing remote handling operations. Figure 2 shows the various cutouts and openings required in the enclosure for the manipulators and the ventilation system. The overall length of the enclosure is approximately 16 meters long and 4 meters wide. Figure 3 shows the TTF enclosure outline, the mercury flow loop equipment, and a pair of mechanical master-slave manipulators that will be used for RH testing.

---

\* This research was sponsored by the Office of Fusion Energy Sciences, U.S. Department of Energy, under contract DE-AC05-96OR22464 with Oak Ridge National Laboratory, managed by Lockheed Martin Energy Research Corporation.

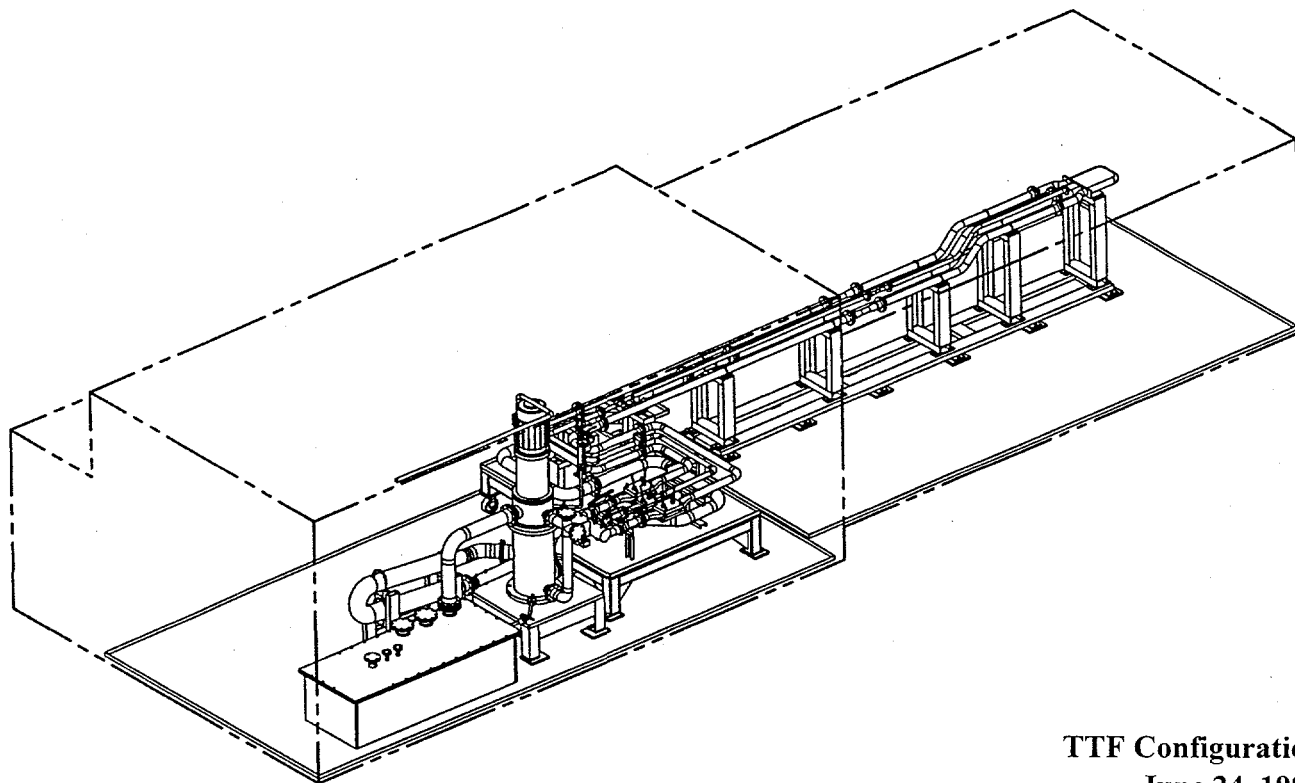

TTF Configuration  
June 24, 1998

Figure 1. Mercury target flow loop equipment.

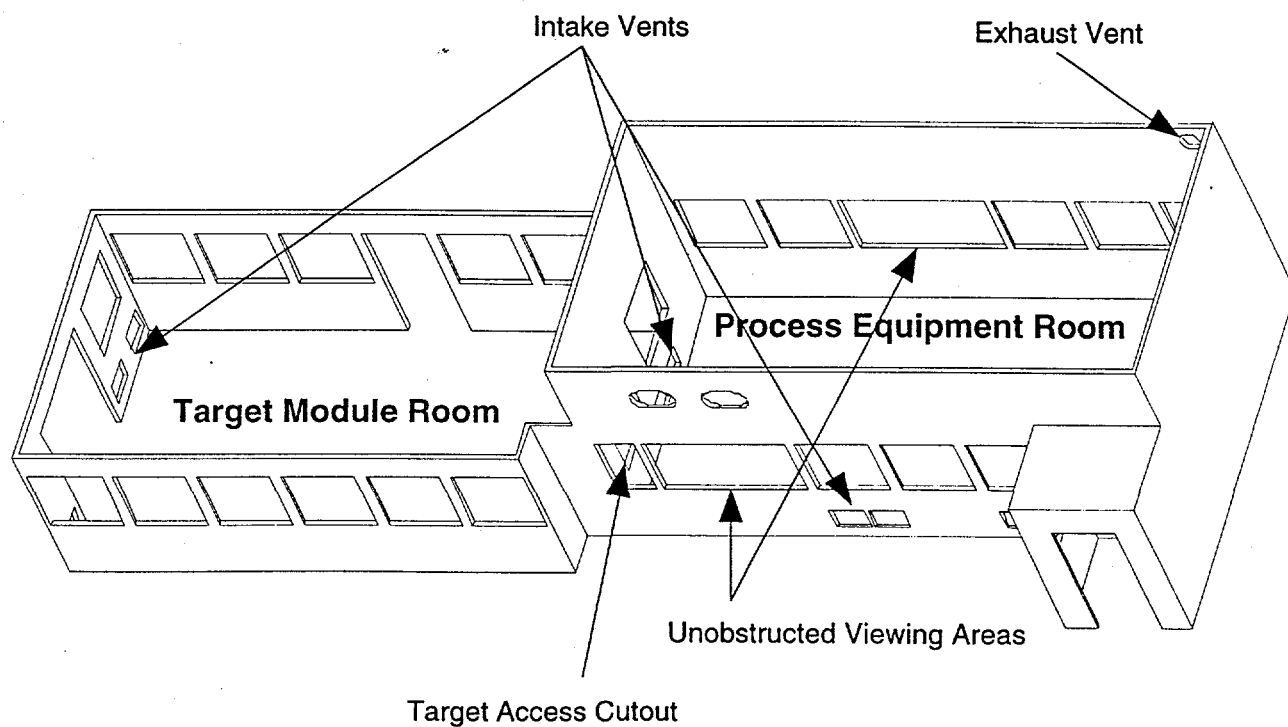
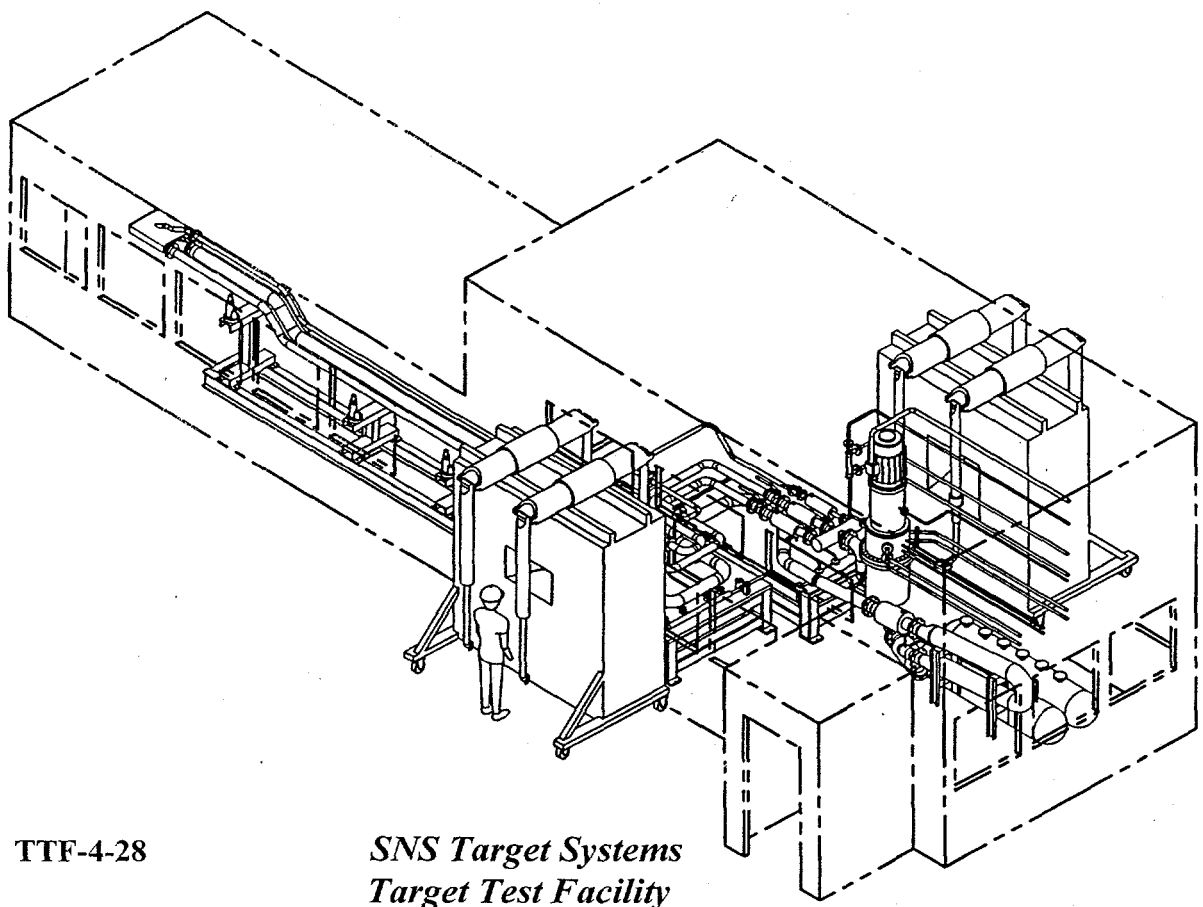

Figure 2. The TTF enclosure arrangement.



TTF-4-28

*SNS Target Systems  
Target Test Facility*

Figure 3. TTF enclosure and mechanical master-slave manipulators.

During remote handling operations, when mercury is not present in the system, the roof of the Process Equipment Room (PER) will be removed to allow access of a bridge-mounted manipulator. Remote handling operations in the PER will be performed primarily using through-the-wall manipulators located along the enclosure walls. In addition, the bridge-mounted power arm manipulator will be available to complement the RH tasks of the wall manipulators.

IV. MANIPULATOR OPERATIONS

A pair of Central Research Laboratory (CRL) Model F manipulators have been mounted onto a movable platform for TTF remote handling operations. The platform can be moved to various locations along the enclosure wall to remotely work on components, and assess the component designs relative to the manipulator arms. Figure 3 shows the CRL manipulators in position against the west wall for operations on the target module-shield interface. The platform can also be installed on the east wall of the enclosure, as shown in the section cut of Figure 4. For RH operations on components that are not adjacent to the

“Target Test Cell” wall, an overhead, bridge mounted PaR 3000 power arm manipulator will be used. Components such as the centrifugal pump will require overhead operations.

V. TTF REQUIREMENTS

A list of general requirements for the TTF was developed to quantify the flow loop equipment, the overall size of the enclosure, safety considerations, and where the TTF could be located. The facility will operate with up to 1 cubic meter of mercury and will be located in Building 7603 at the Robotics and Process Systems Division (RPSD) of Oak Ridge National Laboratory. That particular building contains several bridge-mounted manipulators, two overhead cranes, and adequate floor space to house the TTF. In addition, the staff at the RPSD will provide expertise in RH design and operations because of their involvement in other remote handling programs.

In order to preclude the possibility of personnel exposure to mercury vapors in the event of an accident, the enclosure will be connected to the ventilation system of Building 7603. Five air changes per hour will flow

from the high bay into the enclosure, then through the mercury filters, and finally to the building's vent stack. Mercury monitors will be located upstream and downstream of the filters, as well as at several locations within the enclosure. The locations of the intake and exhaust vents are shown in Figure 2.

Both enclosure rooms will also have a stainless steel floor liner to contain mercury in the event of a spill. The liners will be sized to provide full floor coverage, and will be attached and sealed to the enclosure walls. The liners will be fabricated from 3 mm stainless steel plate, welded and fully inspected for leak integrity. The liners will be installed before the enclosure rooms are erected.

## VI. SCHEDULE

The remote handling test program is based on a four-phase schedule over the next several years. Phases 1 and 2 will be completed in 1999, and include the initial operation of the TTF for mercury flow testing, and demonstrating the remote replacement of pipe jumpers, various sensors, valves and seals. Phase 3 will focus on manipulator accessibility to the various components in the mercury and water cooling loops, use of the remote viewing systems, and replacement of large items such as the mercury pump and heat exchanger. Phase 4 will focus on the remote replacement of the target module.

## VII. CONCLUSIONS

A full-scale prototype of the Spallation Neutron Source Target Station will be constructed. It has two primary test objectives: demonstrate remote handling operations on the components that make up the mercury target flow loop system; and assess the thermal/hydraulic characteristics of the mercury flow loop. In addition to demonstrating the remote replacement of various TTF components, procedures and operations will be developed with this facility to ensure that maintenance operations can be completed in the time allotted to meet the project's availability objectives. The remote handling tests have five objectives: a) verify the replacement of all subsystems and components, b) provide feedback to the Target Station design engineers for design improvements, c) develop and demonstrate appropriate remote handling tools, d) assess downtime for replacing various components, and e) provide operator training for actual remote maintenance operations.

## REFERENCES

1. Spallation Neutron Source Conceptual Design Report, SNS/CDR-2, May 1997.
2. M. J. Rennich, T. N. McManamy, "Overview of the SNS Target Station Remote Handling Systems," Proceedings of the Accelerator Applications '98 Conference, Gatlinburg, Tennessee, September 1998.

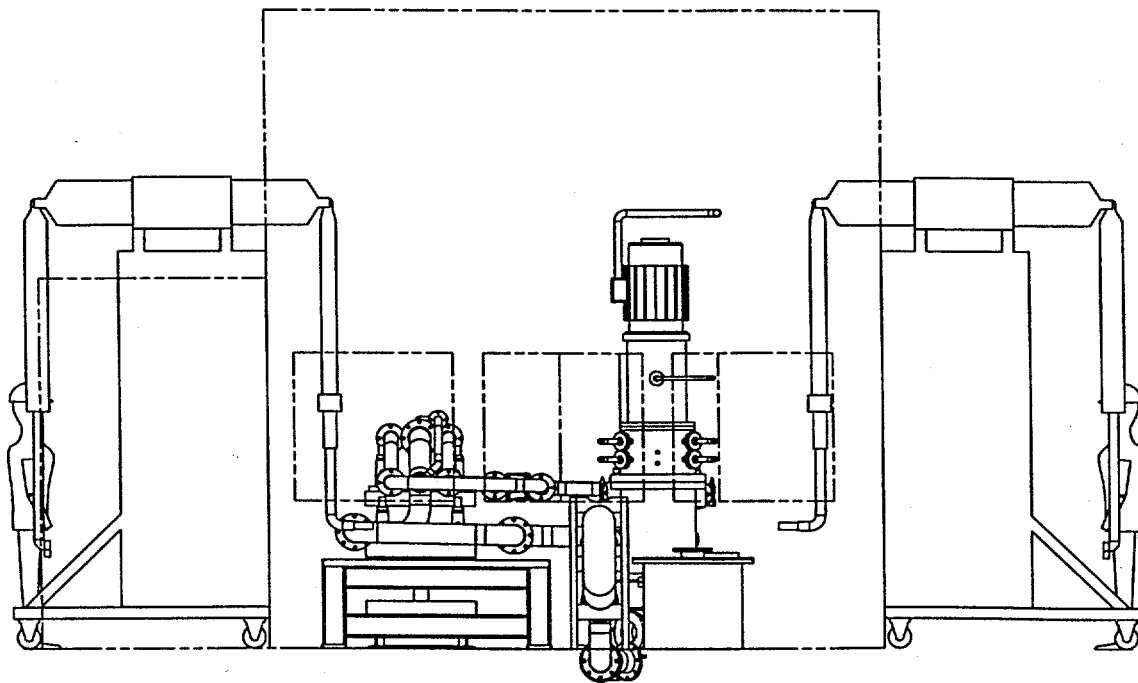

Figure 4. CRL model F manipulators on the TTF east and west sides.