

ANL/XFD/CP--90342
CONF-960848--4

Geometry and Parameter Optimization of PETRA Undulator Beamline Slits

Zhibi Wang* and Ulrich Hahn**

*Argonne National Laboratory
Experimental Facilities Division
9700 South Cass Avenue
Argonne, Illinois 60439

** Hamburger Synchrotronstrahlungslabor HASYLAB
at Deutsches Elektronen-Synchrotron DESY
Notkestraße 85, Hamburg, D-22607, Germany

RECEIVED
JUL 18 1996
OSTI

The submitted manuscript has been authored by a contractor of the U. S. Government under contract No. W-31-109-ENG-38. Accordingly, the U. S. Government retains a nonexclusive, royalty-free license to publish or reproduce the published form of this contribution, or allow others to do so, for U. S. Government purposes.

ABSTRACT

The undulator beamline at the storage ring PETRA of the Hamburger Synchrotronstrahlungslabor HASYLAB delivers hard x-ray photons usable up to 300 keV. The total power of the beam is now up to 7.5 kW with closed gap and 60 mA stored particle beam. After a planned upgrade of the undulator, the power can increase to about 15 kW. The vertical white beam slit for the PETRA undulator beamline is located at about 105 m from the source. The worst case for the slit is when all the power is absorbed in one part of the slit system, which the slits must survive. This paper presents the results from parameter optimization in the worst case. The goal of the optimization is to minimize the maximum temperature of the slits. The geometrical parameters are the cooling hole size, its location from the surface, and the distance between holes. The worst case is found by moving the x-ray beam to all the possible locations. The maximum temperature of an optimized slit that has a two degree angle with the beam is about 192 degrees Celsius. The corresponding thermal stress in the slit is very low. The analysis assumptions, modeling, results, discussion, and conclusion will be given in the paper.

Keyword: x-ray, slit, shape optimization

INTRODUCTION

The first synchrotron radiation beamline using a 4-m-long undulator at the 12 GeV PETRA storage ring delivers hard x-ray photons usable up to 300 keV.¹ The position of the white beam slit for the undulator beamline is located at about 105 m from the source.^{2,3} The installed slit system⁴ can handle the current beam power of 7.5 kW. After an upgrade of the undulator, the total power of the full beam will be doubled and can reach 15 kW. The slits are used to collimate the beam and to protect downstream devices from the power of a missteered beam. In the worst case, one half of the slit will be exposed to the full beam power. In normal operation, slits should not be subject to excessive temperature and thermal stress.

The upgrade of the undulator to a gap height of 11 mm doubles the possible beam power. Therefore the installed slit system⁴ must be replaced by a new design using a normal water-cooling system. The new slit assembly shown in figure 1 is composed of two separate conical shaped slits with a vertical aperture of 10 mm. The beam enters the device from the right. In the full open position, both parts are in one line. The vertical movements of the slits are linked together. The actuator on the right moves the slit parts in opposite vertical directions and reduces the vertical aperture of the assembly. The entrance part of the slit is longer to cover beam misalignments. Due to its high thermal conductivity, copper is used as the slit material. Water is used as the coolant to pass through the cooling channels under the slit surface to take away the heat absorbed by the slit. For such a design with a known material and cooling technique and with the inclined angle of the slit with the beam direction, the maximum temperature in the slit is dependent

DISTRIBUTION OF THIS DOCUMENT IS UNLIMITED

ph

MASTER

DISCLAIMER

This report was prepared as an account of work sponsored by an agency of the United States Government. Neither the United States Government nor any agency thereof, nor any of their employees, makes any warranty, express or implied, or assumes any legal liability or responsibility for the accuracy, completeness, or usefulness of any information, apparatus, product, or process disclosed, or represents that its use would not infringe privately owned rights. Reference herein to any specific commercial product, process, or service by trade name, trademark, manufacturer, or otherwise does not necessarily constitute or imply its endorsement, recommendation, or favoring by the United States Government or any agency thereof. The views and opinions of authors expressed herein do not necessarily state or reflect those of the United States Government or any agency thereof.

DISCLAIMER

Portions of this document may be illegible in electronic image products. Images are produced from the best available original document.

on many geometrical parameters, such as the thickness from the slit surface to the cooling channel, the distance between channels, and the channel diameter, etc. The maximum temperature is also dependent on the relative position of the x-ray beam and the total power absorbed in the slit. Because the two slits are almost identical functionally and structurally, except that one is used for upper part of the beam and the other is used for lower part of the beam, only one slit is considered for optimization in the study.

In order to arrive at an optimized slit design with minimum temperature increment in the slit, a mathematical model is set up as an optimization problem and the finite element method ANSYS⁵ is used to search the design parameter space and find the optimized design. To find the optimized design, first a series of analyses are performed with different x-ray beam locations on the slit. After the worst case beam location is found, (for which the temperature increment in the slit is the maximum), the beam location is fixed for the remaining parameter optimization of the slit design. This paper presents the worst case analysis of the slits with variable slit geometries, i.e., the cooling hole size, its location from the surface, and distance between holes, to minimize the maximum temperature of the slits.

OPTIMIZATION MODEL

As shown in figure 1, the initial design of the PETRA slit is composed of two parts that are linked together by a mechanism. The mechanism guarantees the functional requirement of the slit, and the two parts of the slit can be moved through a single actuator. The slits are located about 105 meters away from the source. The slits may be exposed to full beam in the beam missteering case.

In order to achieve an optimized slit design, a mathematical model must be set up first so that an objection function, design variables, and state variables should be properly identified. In the case of the PETRA undulator beamline slit, some parameters are given and fixed, such as the material used, heat load from x-ray absorption, cooling method, inclined angle that is constrained by its total length, etc. The design variables that can be varied are cooling hole size, distance between two cooling channels, thickness from the slit surface to the cooling channel, and the location of the x-ray beam center. The object is to minimize the maximum temperature in the slit so that the maximum thermal stress can be minimized as a consequence. A feasible design should satisfy all the safety criteria, such as the maximum temperature being lower than melting temperature, maximum Mises stress being lower than allowable stress of slit material, etc. All the geometrical parameters should be within certain limits. The problem can be modeled mathematically as following an optimization problem:

$$\begin{array}{ll}
 \min & T_{\max} = T(w, d, t \text{ etc.}) \\
 \text{S.T.} & T_{\max} < T_{\text{melting}} \\
 & \sigma_{\max} < \sigma_{\text{allow}} \\
 & 0 < w < w_1 \\
 & 0 < d < d_1 \\
 & 0 < t < t_1,
 \end{array}$$

where T_{\max} is the maximum temperature of the slit when the beam is applied at the worst case location, and it is the function of all design variables; w the width between two holes, d the diameter of the hole, t the thickness from the slit surface to the hole, as shown in figure 2, which is a detail of one slit of the slit assembly. The subscript 1 in the above formula represents the upper limit of separate variables. σ_{\max} is the maximum Mises stress found by performing the thermal stress analysis, and σ_{allow} is the allowable stress of the copper material. For example, σ_{allow} can be the yielding stress plus a proper safety margin to prevent low cycle fatigue failure. If low cycle fatigue is allowed during the slit operation lifetime, another allowable stress can be used.

The above mathematical model says that one can find the design that has the minimum T_{\max} by changing all the design parameters in the feasible space. The feasible space is defined by all constraints of the design variables; in addition the maximum Mises stress should be less than the allowable stress and the maximum temperature in the slit should be less than the melting temperature of the slit material.

The slit is at an angle of 2 degrees with the beam. The total thickness of the slit is 2.5 cm. For an initial design, some arbitrary values in feasible space are used as the initial values for the design variables.

PETRA SLIT PARAMETER OPTIMIZATION

Due to symmetry, only half the slit is analyzed in the finite element model. The gap size of the undulator device is assumed to be 11 mm, which amounts to a total power of 15 kW. For conservative purposes, the power is applied only at the surface of the slit, which is a reasonably good model for the problem. The worst case location is found by a series of analyses with different beam locations on the slit. The beam center corresponding to the maximum temperature increment in the slit is located about 2.4 cm inside the slit from the edge. The angle of the slit is assumed to be 2 degrees with the beam direction. The convection coefficient of the cooling channel is 1 W/cm² K. The water temperature is assumed to be 30 degrees Celsius. Because the maximum temperature in the slit is relatively low, heat transfer through radiative cooling can be neglected compared with that through conduction in the slit. Therefore, radiation cooling is not considered in the analysis.

With the beam location fixed, a series of analyses are performed with ANSYS to optimize the design parameters. In ANSYS, there are two optimization tools for a design optimization: the subproblem approximation method and first order method. The subproblem approximation method is an advanced zero-order method that uses approximations for all dependent variables. It is a general method that can be applied efficiently to a wide range of engineering problems. The first order method uses gradients of the dependent variables with respect to the design variables. It is accurate and works well for problems having dependent variables that vary widely over a large range of design space. Both the methods are used here in order to get a best design. In a typical loop of a run, about 20 to 30 analyses are performed for the final results.

Figure 3 shows the finite element model, in which about 8400 elements and 10437 nodes are used for the slit model. After the optimization, it was found that the following parameter values are the optimum: a thickness from the slit surface to the cooling channel of 1.0 cm, a distance between cooling channel centers of 1.6 cm. For the optimized design, the maximum temperature of the slit is 192 degrees Celsius. Figure 4 shows the temperature profile of the slit. The corresponding thermal stress in the slit is about 200 MPa. If an enhanced heat transfer technique, such as porous media, is used in the cooling channel, a better convection coefficient can be achieved at the coolant boundary with the slit. If the convection coefficient is assumed to be 3 W/cm²K, the analysis shows that the maximum temperature in the optimized slit is only 124 degrees C, and the maximum thermal stress is only 120 MPa. In the analyses of the paper, a 30 degree C water temperature is used. The actual coolant temperature at HASYLAB is about 16 degrees C, and therefore the maximum temperature and the maximum thermal stress for the case of the conventional coefficient of 1 W/cm²K can be lowered by about 10 percent.

SUMMARY

In summary, the worst case analysis of the slits with variable slit geometries, i.e., the cooling hole size, its location from the surface, and distance between holes, to minimize the maximum temperature of the slits is described. The worst case is found by moving the x-ray beam to all the possible locations. The maximum temperature of an optimized slit that has a two degree angle with the beam is about 192 degrees

Celsius. The corresponding thermal stress in the slit is about 200 MPa, less than yielding stress of copper material. When the slits are fully closed, they can function as a beam shutter.

ACKNOWLEDGMENTS

The work of this paper was performed at HASYLAB, Germany, under the scholar exchange program between the Advanced Photon Source at Argonne National Laboratory and Hamburger Synchrotronstrahlungslabor HASYLAB at Deutsches Elektronen-Synchrotron DESY. Work supported by the U.S. Department of Energy, BES Materials Sciences, under Contract No. W-31-109-ENG-38. One author (Z.W.) appreciates the help and supports received during his stay at HASYLAB.

REFERENCES

1. K. Balewski, W. Brefeld, U. Hahn, J. Pflüger, and R. Rossmanith, Proceedings of the 16th International Conference on High Energy Accelerators, Dallas (1995).
2. HASYLAB Annual Report (1994), 110 -114.
3. HASYLAB Annual Report (1994), 114 -120.
4. U. Hahn, L. Bittner, M. Hesse, and E. W. Weiner, SPIE 1997, 392 (1993).
5. Swanson Analysis System, Inc., ANSYS Procedures, Rev. 5.1, Sep. 1994.

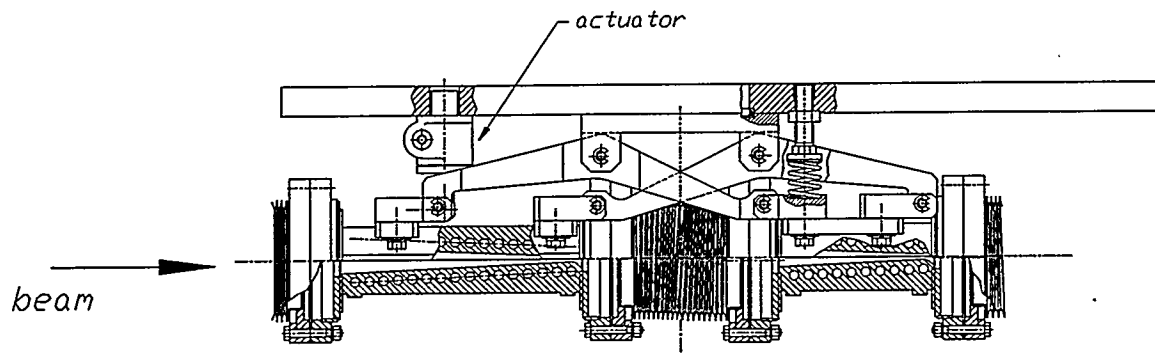

Figure 1. PETRA undulator beamline slit assembly

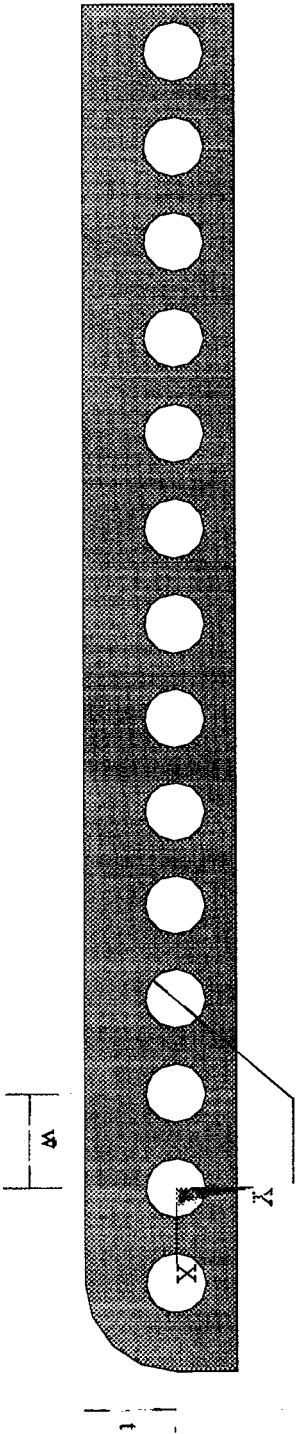

Figure 2. Geometrical parameters of one slit

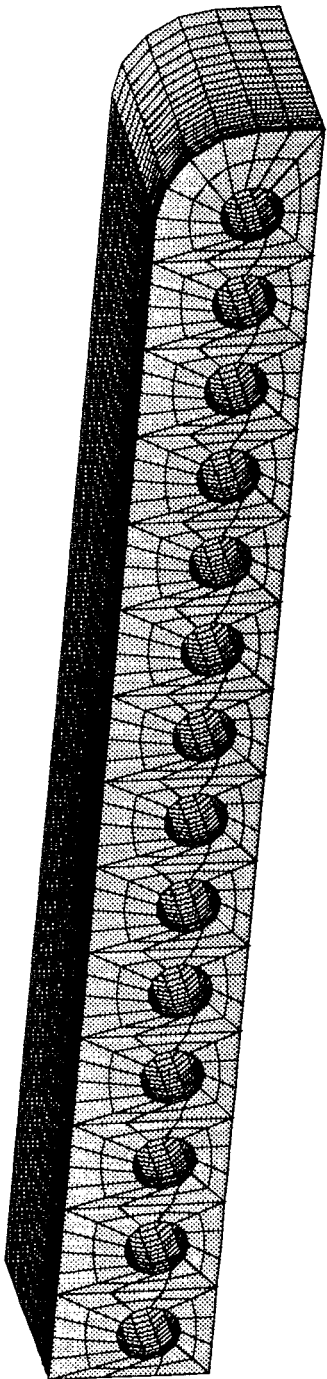

Figure 3. Finite element model used for optimization analyses

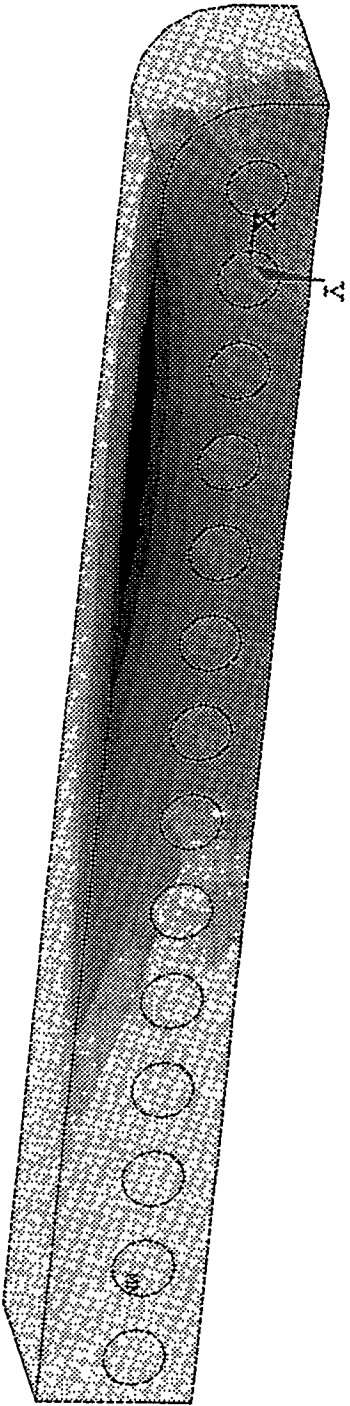

Figure 4. Temperature profile of optimized slit in the worst case