

DOE/CH/10425--3

SOLAR ENERGY INDUSTRIES ASSOCIATION

# Building for the Pacific Rim Nations



DISTRIBUTION OF THIS DOCUMENT IS UNLIMITED

LB

**MASTER**

Energy-Efficient Building Strategies  
for Hot, Humid Climates

DOE/CH/10 425--3

**BUILDING FOR  
THE PACIFIC RIM  
COUNTRIES**

**Energy-Efficient Building Strategies  
for Hot, Humid Climates**

**Compiled and Edited**

**by**

**Kenneth Sheinkopf**

**September, 1991**

**Published by the  
Solar Energy Industries Association  
777 N. Capitol St., N.E.  
Suite 805  
Washington, D.C. 20002  
(202) 408-0660**

## NOTICE

Building for the Pacific Rim was compiled and edited by Kenneth Sheinkopf, and is published by the Solar Energy Industries Association (SEIA). The United States Department of Energy (US/DOE) provided partial funding for publication and production costs. Neither the Solar Energy Industries Association, Florida Solar Energy Center, the United States government nor any agency thereof, nor any of their employees, make any warranties, express or implied, or assume any legal liability or responsibility for the accuracy, completeness, or usefulness of any information, apparatus, product, or process disclosed, or represent that its use would not infringe privately owned rights. Reference herein to any specific commercial product, process, or service by trade name, trademark, manufacturer, or otherwise, does not necessarily constitute or imply its endorsement, recommendation, or favoring by the United States government or any agency thereof. The views and opinions expressed herein do not necessarily state or reflect those of the Solar Energy Industries Association, Florida Solar Energy Center, United States government or any agency thereof.

Printed in the United States of America.

This book is available from: Solar Energy Industries Association, 777 N. Capitol St., N.E., Suite 805, Washington, D.C. 20002.  
Telephone (202) 408-0660.

Single copies are \$35 each, plus \$3 postage and handling.

**DISCLAIMER**

**Portions of this document may be illegible  
in electronic image products. Images are  
produced from the best available original  
document.**



## DISCLAIMER

This report was prepared as an account of work sponsored by an agency of the United States Government. Neither the United States Government nor any agency thereof, nor any of their employees, makes any warranty, express or implied, or assumes any legal liability or responsibility for the accuracy, completeness, or usefulness of any information, apparatus, product, or process disclosed, or represents that its use would not infringe privately owned rights. Reference herein to any specific commercial product, process, or service by trade name, trademark, manufacturer, or otherwise does not necessarily constitute or imply its endorsement, recommendation, or favoring by the United States Government or any agency thereof. The views and opinions of authors expressed herein do not necessarily state or reflect those of the United States Government or any agency thereof.



## PREFACE

This book has been published by the Solar Energy Industries Association (SEIA), the United States trade association of the solar thermal, photovoltaic, and passive solar manufacturers, distributors, and component suppliers. Its purpose is to help architects, builders, and developers construct energy-efficient homes in hot humid climates like the Pacific Rim Countries, and to allow occupants of these homes to enjoy enhanced comfort without reliance on mechanical air-conditioning systems.

The publication was planned in conjunction with the Renewable Energy and Efficiency Application: The Pacific Nations, in September, 1991, in Los Angeles, organized by the U.S. Export Council for Renewable Energy (US/ECRE) to showcase the use of renewable resources throughout the Pacific Rim.

Energy-conscious design has become a major part of today's building profession as the demand for energy-efficient buildings increases. Professional design firms are being asked by their clients to provide buildings that will withstand an extensive energy critique. Architects, builders and contractors need not only the basic principles of energy-efficient design, but also up-to-date, practical information about advanced technologies.

Good passive design principles not only minimize the building's energy consumption, but also maximize the comfort level within the home. Homebuilders and buyers today are seeking "affordable comfort" as well as lower utility bills.

Two important factors are addressed in this book. First, the past few years have seen a tremendous increase in practical applications of new research. The current popularity of ceiling paddle fans, attic radiant barriers and natural daylighting attest to the importance of keeping up with the latest concepts in energy-reduction and comfort-awareness. Professionals who have been in the field for the past few years may be unaware of the latest research findings — some of which dramatically alter prior thinking on such subjects as natural ventilation or mechanical air conditioning.

The second factor is the importance of site-specific characteristics, which greatly affect building strategies and designs. A thorough understanding of the climate is a prerequisite to good building design. Such factors as temperature, humidity, wind speed and direction, and solar radiation must be understood and properly integrated into the design for the home to be truly energy-efficient.

Both of the above factors are addressed in this book, and it is hoped that this material will form a useful reference manual for architects, designers, builders, government officials, and others involved with home construction in Indonesia, Malaysia, the Philippines, Thailand, and other Pacific Rim Countries. Energy-efficient construction can be a reality in the Pacific Rim if the principles and ideas in this manual are utilized appropriately. Study these ideas, use them in your designs, and both you and the homeowners will benefit from the resulting energy conservation and improved home comfort.

Material in this book is based on research conducted at the Florida Solar Energy Center (FSEC), a research institute of the State University System of Florida. It has been compiled and edited by Ken Sheinkopf, who is Director of Special Projects for SEIA. FSEC operates a solar energy research and training center for the Caribbean countries, and can provide additional information on energy-efficient building strategies in hot, humid climates. For more information on their programs, contact the Florida Solar Energy Center, 300 State Road 401, Cape Canaveral, Florida 32920-4099, U.S.A.

SEIA is especially indebted to Dr. David Block, Director of the Florida Solar Energy Center, and other members of the FSEC staff for their research which formed the main content of this book. In particular, we'd like to acknowledge the work of Subrato Chandra and Philip Fairey of FSEC, who wrote the first draft of the manuscript for this publication. Chandra, who is Director of the Research and Development Division at FSEC, has published a number of other books and papers on ventilative cooling, solar water heating, and other aspects of solar cooling and passive design, and has consulted with governments in the Caribbean. Fairey is Program Director for Buildings Research at the Center, and has extensive experience in research on radiant barriers, natural ventilation, and building dehumidification. He has also worked with Caribbean governments on passive solar projects. In addition, some of his material used in this book has appeared in *Multi-Family Buildings: Designs for Warm, Humid Climates*, part of a series of books sponsored by the Owner/Builder Center at Miami-Dade Community College.

Other FSEC researchers who have made significant contributions to this book are Ross McCluney (building fenestrations), Tim Merrigan (hot water), Gerard Ventre (photovoltaics), Michael Houston (climate balanced design, fenestrations and ventilation), and Mukesh Khattar (mechanical systems). We appreciate FSEC allowing us to publish this information for the benefit of the builders and homeowners throughout the Pacific Rim.

Special thanks are also due to Bion Howard of The Alliance to Save Energy, who provided a detailed technical review of this book and offered many suggestions of special interest to builders in the Pacific Rim, and to Mark Bailey

of the U.S. Department of Energy, who also provided detailed comments and useful suggestions on the manuscript.

We are also indebted to John Millhone, Director of the Office of Buildings and Community Systems of the U.S. Department of Energy, who provided support and assistance during the production of this book. The Department of Energy supported SEIA with publication costs to allow us to make the book available to architects, designers, and builders throughout the Pacific Rim countries.

Finally, I would like to acknowledge two members of SEIA's staff who assisted Ken Sheinkopf with the preparation of this book: Jon Holub, who edited the material and updated Pacific Rim information, and Sandy Rupp, who designed the book. We also appreciate the assistance of the graphics staff at FSEC who prepared the many figures and illustrations used throughout the publication. And a special thanks to the builders, designers and other professionals in the Pacific Rim nations who will use the strategies and guidelines of these pages to bring improved home comfort and significant energy savings to their clients.

Scott Sklar, Executive Director  
Solar Energy Industries Association  
Washington, D.C., U.S.A.  
September, 1991



# TABLE OF CONTENTS

## Preface

### 1. CLIMATE

Introduction	1
Building Information	1
Climate Data	2
Temperature	2
Windspeed and Direction	3
Solar Radiation	4

### 2. FUNDAMENTALS

Introduction	5
Conduction	5
Convection	5
Radiation	6
Human Body Responses	7
The Comfort Zone	9
Solar Motion	14
Landscaping	14

### 3. BUILDING COMPONENTS

Introduction	17
Insulation	17
Radiant Barriers	22
Exterior Finishes	23
Window Design	27

### 4. NATURAL VENTILATION

Good Ventilation	29
Ventilation Augmentation by Wingwalls	32
Design Strategies Using Wingwalls	33
Trees and Landscaping to Channel the Winds	35
Airflow on Roofs and Whole-House Roof Ventilators	36
Room Ventilation Strategies	38
Example House Plans	40
Internal Loads	46

## 5. AIR CONDITIONING AND DEHUMIDIFICATION

Introduction	49
Choosing an Air Conditioner	50
Heat Pump Water Heaters	51

## 6. BUILDING DESIGN

Thermal Energy Storage	53
Air Infiltration	54
Shading and Daylighting	55
Shading	56
Glass	58
Visual Comfort	60

## 7. HOT WATER FOR HOT CLIMATES

Introduction	63
Hot Water Principles	63
Uses	63
Temperature	64
Requirements	65
Demand Periods	66
Distribution	67
System Types	68
System Sizing and Orientation	71
Storage Tank	72
Materials	72

## 8. PHOTOVOLTAICS

Photovoltaic Effect	73
Peak Sun Hours	73
Cell Materials	73
Modules and Arrays	73
Current-Voltage Characteristics	74
Array Types	75

## 9. RECOMMENDATIONS FOR BUILDING A HOME IN THE PACIFIC RIM

Site	77
Building Layout	77
Windows and Skylights	77
Doors	78
Floor Insulation	79
Wall Insulation	79
Roof Insulation	79
Infiltration	80
Shading	80
Finishes	81
Ceiling Fans	81
Mechanical Systems	82
Domestic Hot Water	83
Occupant Guidelines	84

## 10. APPENDIX

Glossary	85
For Further Information	91
Solar Energy Industries Association	99

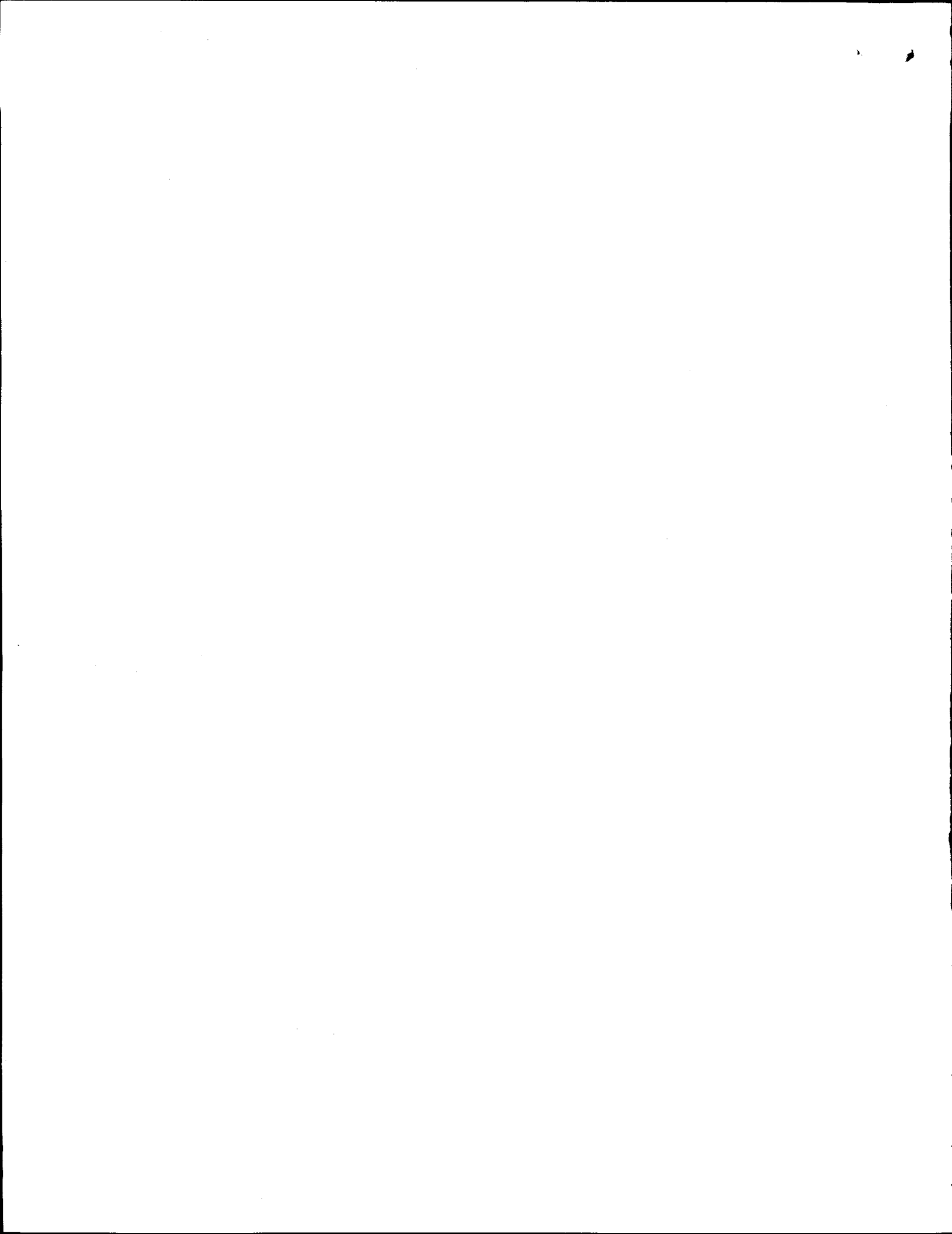

# CHAPTER 1

## CLIMATE

### Introduction

A thorough understanding of the climate is a prerequisite to good building design. To give an example of the kind of information needed for your location, this chapter presents sample selected data on Indonesia, Malaysia, the Philippines and Thailand, with particular emphasis on temperature, humidity, wind speed and direction, and solar radiation. It is important to collect this data before planning buildings in other locations throughout the Pacific Rim.

Most of the data you need can be provided by your country's national weather service. Another excellent source of weather data is the National Climatic Data Center (See Appendix for address). They publish a number of reports and weather summaries for all parts of the world. While most of their studies cover the United States, several reports, such as *Climates of the World* and *Monthly Climatic Data for the World*, cover most areas outside of the U.S. Contact them for a current list of publications and prices.

One other excellent publication is *World-Climates*, which provides temperature ranges, recommended clothing, heat stress levels, precipitation and other data for most areas.

### Building Information

Before looking at climate information, it is important to consider the types of buildings and the building materials that are used. Most government and major tourist buildings throughout the Pacific Rim nations are built to Western standards, often to U.S. Federal Housing Authority regulations. Buildings are often air conditioned, but rarely heated.

In the westerly islands in Micronesia and Polynesia, residential buildings use concrete block, poured cement (sometimes reinforced with steel rods) and wood. Roofs are usually corrugated tin or thatch. Heating is not necessary because the temperatures are comfortable all year long. Air conditioning is used in a minority of homes.

It is quite common for building materials in the Pacific Rim nations to be manufactured on the west coast of the U.S. and shipped to the islands. There is little local manufacturing of building materials.

In Micronesia, for example, families live together, with 10 to 12 members in a typical home. Dwellings have two or three bedrooms, with more for larger families. A typical housing arrangement is for a family to have a cluster home—a concrete structure surrounded by several “local buildings.” The concrete building, where the mother and father live, has concrete walls and floor, with trusses supporting the tin roofing material or thatch. The “local buildings,” used for cooking and sleeping, are open structures made of wood with thatched or tin roofs, and mosquito netting pulled down at night.

## Climate Data

Table 1 gives examples of the type of information available from these sources.

**Table 1**  
**Climatic Description**  
**Indonesia**

Most of the islands are very mountainous with numerous volcanic peaks and other mountain ranges exceeding 10,000 ft (3000 m). There are consequently many sharp local differences of climate within Indonesia; not only are temperatures much lower in the hills but the amount and season of maximum rainfall varies with the different exposure of the islands to the two main seasonal wind systems. The whole archipelago is alternately dominated by the north monsoon, blowing from China and the north Pacific between November and March, and the south monsoon blowing from the Indian Ocean and the Australian continent between May and September. For a few weeks around April and October the winds are light and variable in direction; this is the period of transition when the Doldrum belt, or inter-tropical convergence, moves north or south across the islands.

Apart from the reduced temperatures on the higher mountains, the weather and climate of Indonesia are typical of equatorial regions. Rainfall is almost everywhere heavy and well distributed around the year. Most places receive between 60 and 160 in (1500 and 4000 mm) of rain a year. Many places have two wetter periods during the passage of the Doldrum belt; but south-facing coasts and islands south of the equator tend to be wetter during the period of the south monsoon and north-facing coasts and the northern islands are wetter during the period of the north monsoon.

Much of the rainfall is heavy and accompanied by thunder. Some parts of Indonesia have more thunderstorms than anywhere else in the world. In spite of the heavy rainfall sunshine hours are abundant in Indonesia. During the wetter months sunshine averages four to five hours a day and this rises to eight or nine hours a day during drier periods. Jakarta, one of the drier places in the country, receives three times as much rain as London but it falls on fewer days per year and for only half the number of hours.

Temperatures remain high throughout the year and there is very little difference from month to month. There are only two types of weather in Indonesia: fine and sunny or cloudy and wet. Only the extreme southern islands, such as Timor, are occasionally affected by strong winds associated with tropical cyclones; but local wind squalls may occur during thunderstorms. On the coast the daily range of temperature is small but this increases inland and in the hills. The cooler nights inland and the daytime sea breezes and strong monsoon winds afford the chief relief from the heat and humidity on the coast.

## Temperature

Information on the temperature of the region is important. Knowing the temperature ranges, relative humidity and amount of precipitation can be very helpful in designing the best type of building for the climate.

Table 2 gives detailed weather information for Kuala Lumpur, Malaysia. The average daily temperatures clearly illustrate the moderate climate in the region.

**Table 2**  
**Temperature, Relative Humidity, and Precipitation**  
**Kuala Lumpur, Malaysia**

	Temperature °F			Temperature °C			Relative humidity		Precipitation					
	Highest recorded	Average daily	Lowest recorded	Highest recorded	Average daily	Lowest recorded	0700 hours	1300 hours	Average monthly		Average no. days with 0.01 in + (0.25 mm +)			
	max.	min.		max.	min.		%	%	in	mm				
J	96	90	72	64	36	32	22	18	97	60	6.2	158	14	J
F	98	92	72	68	37	33	22	20	97	60	7.9	201	14	F
M	98	92	73	68	37	33	23	20	97	58	10.2	259	17	M
A	96	91	74	70	36	33	23	21	97	63	11.5	292	20	A
M	97	91	73	69	36	33	23	21	97	66	8.8	224	16	M
J	96	91	72	68	36	33	22	20	96	63	5.1	130	13	J
J	96	90	73	67	36	32	23	19	95	63	3.9	99	12	J
A	96	90	73	68	36	32	23	20	96	62	6.4	163	14	A
S	95	90	73	68	35	32	23	20	96	64	8.6	218	17	S
O	95	89	73	69	35	32	23	21	96	65	9.8	249	20	O
N	95	89	73	69	35	32	23	21	97	66	10.2	259	20	N
D	95	89	72	66	35	32	22	19	97	61	7.5	191	18	D

### Windspeed and Direction

Table 3 gives an example of windspeed data for 16 stations in the Philippines. Note that windspeed is highly variable, particularly when tropical cyclones pass near the area. It has been estimated that windspeeds during cyclones have exceeded 50 m/sec to 75 m/sec. There are also increases in windspeed during monsoons, when winds of 15 m/sec or greater have been recorded.

Coastal stations have recorded the effects of land and sea breezes, and inland stations observe the effects of mountain and valley breezes. Most stations report the highest winds during the day.

**Table 3**  
**Mean Monthly and Annual Prevailing Winds**  
**and Average Windspeeds (m/sec)**  
**The Philippines**

Station	Jan.	Feb.	Mar.	Apr.	May	June	July	Aug.	Sep.	Oct.	Nov.	Dec.	Annual average
Manila CO	NE/2	E/2	SE/2	SE/3	SE/3	SW/3	SW/3	SW/4	SW/3	NE/2	NE/2	NE/2	SW/3
Baguio	SE/4	SE/4	SE/3	SE/3	SE/4	SE/3	W/5	W/5	W/4	SE/3	SE/4	SE/3	SE/4
Pto. Princesa	NE/1	NE/1	NE/1	W/1	W/1	W/1	W/1	W/1	W/1	W/1	W/1	NE/1	W/1
Manila MMO	E/3	SE/4	SE/4	SE/4	SE/4	SE/3	SW/3	S/2	SE/2	SE/2	SE/2	E/2	SE/3
Laoag	N/3	N/3	N/3	NW/3	W/3	S/3	SSW/3W	SSW/3	SSW/2	N/3	N/4	N/3	N/3
Zamboanga	NE/2	N/2	W/2	N/2	N/2	N/2	N/2	W/2	W/2	W/2	W/2	W/2	W/2
Jolo	NE/3	NE/3	NE/3	S/2	S/3	S/3	S/4	S/3	S/3	S/3	S/3	S/3	NE/3
Iloilo	NE/6	NE/5	NE/6	NE/5	NE/3	SW/3	SW/4	SW/4	SW/3	NE/3	NE/4	NE/5	NE/4
Cebu	NE/4	NE/3	NE/4	NE/3	NE/3	SW/3	SW/3	SW/4	SW/3	SW/3	NE/3	NE/3	NE/3
Dumaguete	N/2	NE/2	NE/2	NE/1	NE/1	NW/1	SW/1	SSW/1	SSW/1	NE/1	NW/1	NE/2	NE/1
Cagayan de Oro	N/2	N/2	N/2	N/2	NE/2	NE/2	N/2	N/2	N/2	N/2	N/2	N/2	N/2
Aparri	NE/4	NE/3	NE/4	NE/3	NE/3	S/3	S/3	S/3	S/3	NE/4	NE/4	NE/4	NE/3
Legaspi	NE/4	NE/3	NE/3	NE/3	NE/2	SW/2	SW/3	SW/3	SW/3	NE/3	NE/3	NE/4	NE/3
Tacloban	NW/3	NW/3	NW/3	NW/3	SE/3	S/3	W/2	W/2	W/2	W/3	W/3	NW/3	NW/3
Davao	N/3	N/3	N/2	N/2	N/2	S/2	S/2	S/2	S/2	N/2	N/2	N/2	N/2
Surigao	NE/3	NE/3	NE/3	NE/2	E/2	SW/2	SW/3	SW/3	SW/3	SW/2	NE/2	NE/2	NE/2
<b>Prevailing average</b>	NE/3	NE/3	NE/3	NE/3	NE/2	SW/2	SW/3	SW/3	SW/2	NE/2	NE/3	NE/3	NE/3

## Solar Radiation

The dominant cause of overheated buildings in hot, humid climates is the sun. Table 4 gives an example of monthly solar irradiation for Thailand.

**Table 4**  
**Monthly Solar Irradiation**  
**Thailand**

SITE	JAN	FEB	MAR	APR	MAY	JUN	JUL	AUG	SEP	OCT	NOV	DEC	AVG
Bangkok	4.70	4.94	5.48	5.58	5.08	4.73	4.59	4.47	4.31	4.38	4.76	4.71	4.81
Ban La													
Mai	4.44	5.58	5.75	5.97	5.64	5.00	5.03	4.50	4.61	4.17	3.83	4.31	3.05
Bang Na	5.03	5.72	5.53	5.75	5.94	4.89	5.17	4.69	4.17	3.78	4.64	4.89	4.77

NOTE: The figures following the site show the mean daily global horizontal irradiation in kWh/m<sup>2</sup> per day. All irradiance was measured using a pyranometer.

The data shown in this chapter is from *World Weather Guide* by E.A. Pierce and Gordon Smith (New York: Times Book/Random House, 1990) and *International Irradiation Database Southeast Asia and the Pacific*, (Lowell, MA: University of Lowell Research Foundation, 1991). This data is helpful in building for the climate to keep structures energy-efficient while improving indoor comfort.

## CHAPTER 2

### FUNDAMENTALS

#### Introduction

Three modes of heat transfer exist in nature — conduction, convection and radiation. More thermally energetic (hotter) bodies attempt to give up their excess energy to less energetic (cooler) bodies by some or all of these means. The driving force of the transfer is the difference in temperature between the two bodies - the greater the difference, the greater the rate of heat flow.

#### Conduction

Heat transfer through solid bodies is called conduction and is probably the most familiar of the heat transfer mechanisms. This is the method by which the handle of a metal spoon which is left in a pot of hot liquid is heated.

The rate at which heat is transferred through solid objects is referred to as the material conductivity. Metals have high thermal conductivities and gases have low thermal conductivities. There is no conduction through a vacuum. Air is a poor conductor and is often used as an insulator in the form of trapped air spaces to retard heat flow.

#### Convection

Air which is not confined, however, does serve as a medium by which heat can be transferred. This type of heat transfer is called convection. Convection is a buoyancy driven heat transfer mechanism which uses a fluid (gas or liquid) to transfer thermal energy from a warmer body to a cooler body. When air (or any other fluid) comes into contact with an object which is warmer than it is, some of the heat is transferred to the fluid. As the fluid warms it becomes lighter than the surrounding fluid and it rises; cooler fluid is drawn in to replace it and the process continues until thermal equilibrium is reached. If a warm body and a cool body are separated by a fluid which is in contact with both, then a convective loop will be established. The fluid will be warmed by the hot body and rise. When the warmed fluid comes in contact with the cooler body it will give up heat and fall, creating a natural convection current by which the heat is transferred from the warmer to the cooler body.

Convection is sometimes greatly augmented by fans, pumps, or blowers. This is called forced convection. Air conditioners and heaters use forced convection to distribute heated or cooled air from the central conditioning

coil to the remainder of the space. Forced convection is also quite important to human comfort where airflow can have a substantial effect on the perception of comfort. Convective heat transfer into and out of the interior of the building can be rather easily controlled through opening and closing the building envelope.

## Radiation

The impact of radiative heat transfer on building energy performance is a fairly new field of study. It is the only transfer mechanism which operates across a vacuum and is the primary means of energy transfer throughout the universe. Solar radiation is the cause of environmental overheating and is most often the major source of building overheating.

On the earth, two different radiative heat transfer processes occur. The first is solar radiation and is relatively well understood. This type of radiation is generally referred to as shortwave radiation. The second is called longwave radiation and most often is indirectly caused by the first.

The difference between the two is suggested by the names. Radiation coming to earth from the sun is composed of electromagnetic waves of relatively short wavelengths. Only a small portion of this radiation is in the form of visible light. However, the sun is not the only object which generates radiation. All objects which are at a temperature greater than absolute zero (0 degrees K = -273 degrees C) generate electromagnetic radiation. The wavelength of this radiation is a function of temperature of the radiating body, with hotter bodies generating shorter and more energetic wavelengths than cooler bodies.

The earth and its associated bodies have an absolute temperature in the vicinity of 300 degrees K. This generates radiation with wavelengths in the range from 4 to 22 microns (um). Solar radiation, on the other hand, contains much shorter and more energetic wavelengths in the range from 0.3 to about 3 microns. Only the portion between 0.4 and 0.7 microns represents visible light. The differences in wavelength produce different responses to each type of radiation. For instance, the gas carbon dioxide is transparent to shortwave solar radiation but is opaque to a large portion of longwave infrared radiation. This fact is critical to the survival of the earth as it causes the "greenhouse effect," keeping the earth at a relatively stable temperature.

Both shortwave and longwave radiation are absorbed by most building materials. When these materials absorb radiation, their energy content, and thereby their temperature, is elevated. The roof of a building which is absorbing shortwave solar radiation at its surface may reach temperatures which are up to 100 degrees F higher than the surrounding air temperatures. This,

in turn, establishes a large temperature difference between the roof and the building interior. The roof will transfer its energy into the building interior by longwave radiation in an attempt to come to equilibrium with its environment. Since the roof is not in direct contact with any other material, and since convective heat transfer is extremely weak when the direction of heat flow is down, the great majority of heat transfer from a roof into a building must take place by radiative heat transfer.

The degree to which longwave radiation is effective as a heat transfer mechanism is controlled by three variables: the temperature difference between the radiating bodies, the solid angle of view between the bodies (called the view factor), and a variable material property called emissivity. In most buildings, temperature differences are primarily controlled by the exterior environment and view factors are controlled by limitations of building geometry. As a result, the major determinant of radiative heat transfer within building spaces is the emissivity of the building materials themselves.

Emissivity is a dimensionless material property which ranges between zero and unity in value. The emissivity of a material expresses the numerical propensity of the material to radiate to its surroundings as compared to the radiation potential of a perfect "blackbody". A perfect blackbody would have an emissivity of unity and a perfect nonradiating body would have an emissivity of zero. Neither material exists in nature, but deep space comes closest to being a blackbody and certain bright metals such as gold, silver, and aluminum exhibit very low emissivities. Most common building and insulation materials have emissivities in the rather high range of 0.8 to 0.95 and as a result radiative heat transfer is a powerful force in building spaces. See Chapter 3 for information on the use of Radiant Barrier Systems in tropical climates.

## Human Body Responses

The human body constantly generates excess heat. This occurs through the metabolic process whereby food is converted to body energy. This energy is in turn used to perform useful work producing excess body heat as a by-product. The amount of heat produced by the body is proportional to activity level, with more strenuous activities producing higher levels of excess body heat. Seated and at rest, the body produces about 400 Btu per hour of excess heat which must be dissipated. In contrast, climbing a steep set of stairs produces an excess of 4,400 Btu per hour. Since humans are warm-blooded mammals, the body needs to maintain deep body temperatures near 98.6 degrees F to prevent serious medical complications, and the body accomplishes this in rather remarkable ways. For instance, if the environment is very cold the body will involuntarily shiver, or work to produce more body heat to keep deep body temperatures at their required levels.

Likewise, the body has a number of mechanisms to dissipate heat when the environment is overheated. The human body exhibits all normal heat transfer mechanisms (conduction, convection and radiation). In addition, it has the rather remarkable ability to regulate perspiration and cool itself by evaporative heat loss.

Under the most desirable temperature and humidity conditions (e.g., 75 degrees F, 50% relative humidity), most body-heat rejection occurs through convective and radiative heat transfer, with only about 20% occurring through evaporation. Very little loss occurs by conduction. As environmental conditions change, body temperature regulation systems react accordingly. For instance, if activity is held constant and dry-bulb temperature rises to 90 degrees F, about 80% of the body's heat loss occurs through evaporation, requiring profuse perspiration. Under these conditions, radiation and convection are much less important than evaporation (Figure 1).

**Figure 1**  
**Body Heat Loss and Air Temperature**

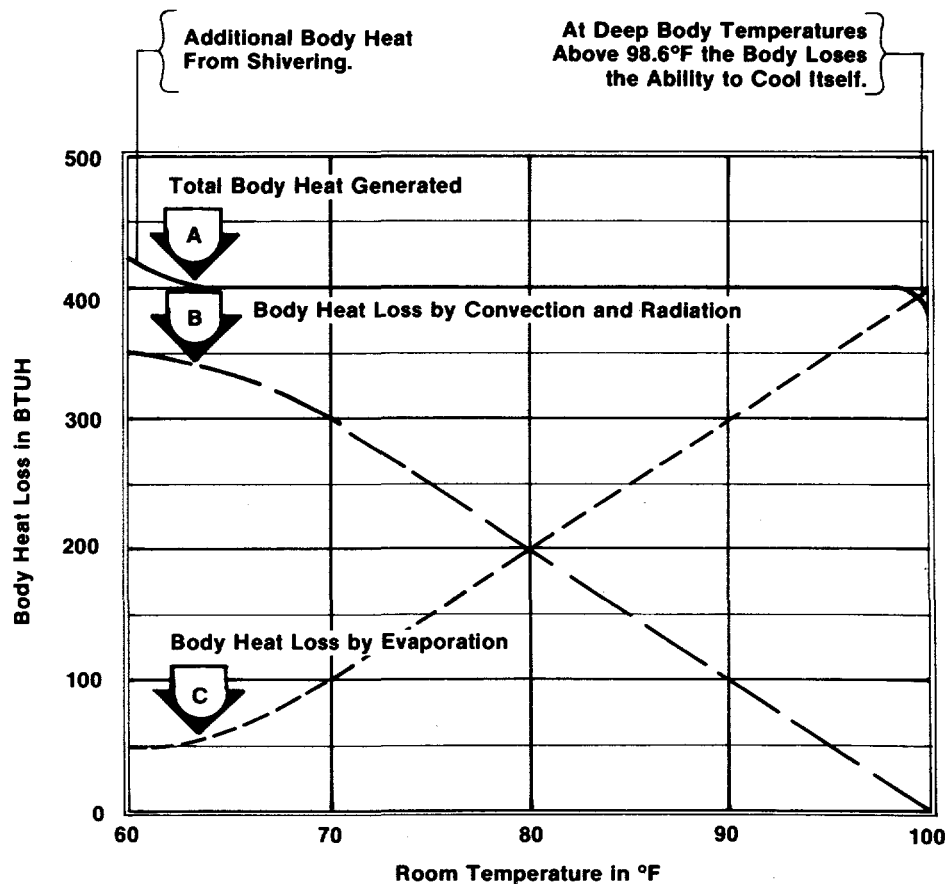

As air temperature approaches skin temperature (92–94 degrees F), most body heat loss must occur through evaporation. If the air has a high relative humidity, the potential for evaporation to take place is greatly reduced because the air cannot easily absorb more moisture. Theoretically, when the relative humidity reaches 100% and the air temperature exceeds skin temperature, the body can no longer evaporate moisture or convect heat away from itself, and the potential for very serious and even terminal body overheating exists (i.e., heat stroke)

## The Comfort Zone

Many statistical studies have been performed on large numbers of subjects of all ages, sexes and nationalities to arrive at a quantitative description of human comfort. This is necessary to provide goals and design parameters for human comfort in buildings. As previously mentioned, the results of these studies provide a comfort zone with a relatively wide band of acceptability in which 80% of the population experiences the sensation of thermal comfort.

Comfort zones are usually expressed graphically as an overlay on the psychrometric chart or other chart which relates temperature and humidity. A few comfort charts attempt to express the additional major comfort variables of Mean Radiant Temperature (MRT) and air motion. When an individual is seated and at rest, and the MRT is equal to air temperature and when there is no substantial air motion (less than 50-feet-per minute), the comfort chart appears as shown in Figure 2. There are two distinct zones which overlap, one labeled winter and one labeled summer. Their difference is primarily attributable to differences in normal clothing levels between winter and summer.

Figure 2  
Basic Comfort Zone

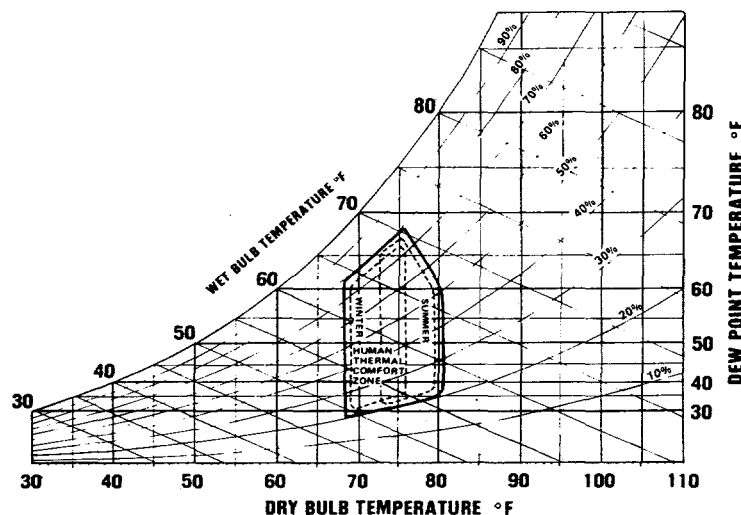

There are additional variables affecting comfort which can have overriding effects on human comfort. It is now relatively well known among building analysts, for instance, that the mean radiant temperature of a building environment is of great importance to comfort.

At optimum levels the radiant exchange of the human body with its surroundings can account for almost 50% of the body's ability to lose heat. Therefore, if MRT is increased, the net radiant exchange from the body to its surroundings will decrease, and if MRT is decreased, the net radiant exchange from the body to its surroundings will increase. This has proven to be a very powerful passive building technique for both heating and cooling.

Through the use of materials capable of storing relatively large amounts of thermal energy (concrete and masonry products, water, and phase change materials) and heat collection and rejection techniques, passive building designers have effectively used this principle in a number of design configurations. The most notable historical examples are the American Indian dwellings in the hot, dry Southwest where large volumes of thermal mass, strategic placement of windows, and large diurnal temperature swings combine to produce dwellings which maintain almost constant internal comfort throughout the year in spite of large daily and seasonal fluctuations in ambient conditions.

A second major influence on comfort is increased air motion across the skin, which can greatly increase the tolerance for higher temperature and humidity levels. Research accomplished by P.O. Fanger with large numbers of subjects has shown, for instance, comfort can be maintained at 82 degrees F and 100% relative humidity as long as air velocities of 300-feet-per minute across the skin are maintained. Most good ceiling fans will produce this magnitude of air motion. At lower relative humidities (50% and below), much higher temperatures (almost 90 degrees F) are comfortable at this air velocity.

Air motion across the skin accomplishes cooling through both convective energy transfer and latent energy transfer (evaporation of perspiration from the skin). Since skin temperatures are relatively high, even 90 degrees F temperatures can carry off some excess heat by convection. Additionally, if dry-bulb air temperatures are lower than skin temperatures, evaporation from the skin can occur even at very high relative humidities.

The skin is surrounded by a thin, still air layer which is close to skin temperature and insulates the body from its environment. If dry-bulb air temperatures are less than skin temperature, then the relative humidity of the air in contact with the skin is lowered somewhat (due to its increased dry bulb temperature) and evaporation from the skin will occur. Increasing air motion heightens this effect. This air motion both decreases the thickness of the in-

ulating air layer and carries off excessively heated and moisture-laden air. Therefore, increases in human comfort due to air motion can be rather profound.

An expanded version of the comfort zone (Figure 3) has been provided by Givoni. It shows what can be achieved through effective passive building design. The basic building Givoni chose was one with negligible internal loads and whitewashed walls and roofs. The various zones are based on exterior climate conditions and show building comfort potentials for selected building design techniques. The effects of combined techniques are not shown.

**Figure 3**  
**Expanded Comfort Zone**

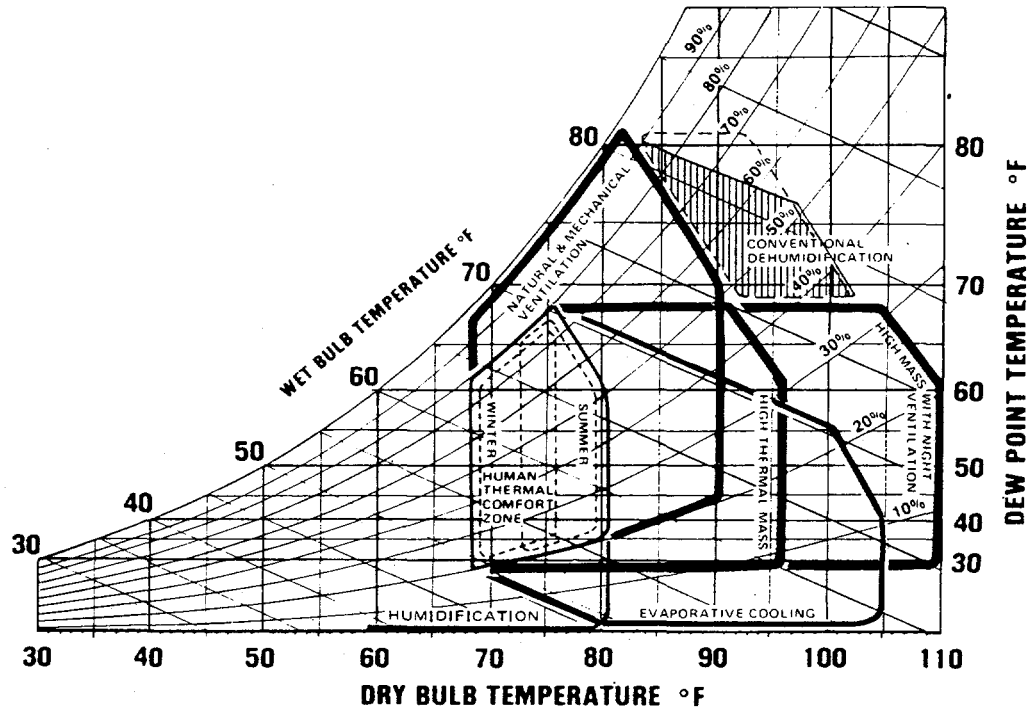

The shaded area has been added to indicate the additional potential of certain combined techniques. For instance, the wise use of thermal mass and ventilation in this zone may produce comfortable interior conditions.

Even without relying on experimental techniques, there already exists a major body of knowledge which permits carefully designed buildings to provide desirable comfort levels with much less dependence upon mechanical air conditioning systems.

The Florida Solar Energy Center has also developed two sets of comfort charts. The comfort zones derived from the analysis are plotted in a simple temperature versus relative humidity format rather than as overlays to the psychrometric chart.

One set is for use in residential environments where the clothing and activity level can be more liberal than in the workplace. The other was developed for office use. A winter and a summer zone are shown in both sets. Variation in clothing level (clo value) allows comfort at a lower temperature in winter and higher temperatures in summer. This is a realistic assumption since normal attire will change from season to season because of exterior weather conditions.

The comfort zone for home environments is shown in Figure 4 on the next page. The following assumptions were used in its development.

PARAMETER	HOME
met rate:	0.2
Clo value	
summer:	0.5
winter:	0.9

These values were held constant and dry-bulb temperature, relative humidity and air velocity across the skin were varied to arrive at the chart shown. The Predicted Mean Vote (PMV) was held to + 0.5 for these calculations. A PMV of + 0.5 corresponds to 90% of the population being satisfied; therefore, the chart is slightly more restrictive than the ASHRAE Comfort Standard. The optimal comfort lines shown correspond to a PMV of zero, corresponding to 95% satisfaction—the greatest percentage of satisfaction attainable.

Changes in the optimal summer comfort line due to increased air motion across the skin are shown for various air velocities up to 400 fpm. The entire zone boundaries are shown only for conditions of 0-20 fpm air velocity. However, the upper and lower extremities of the zones at 150 fpm and 300 fpm are also shown at their summer corners to indicate how the zone will shift with changes in air velocity.

Comfort is achievable at relative humidities up to and including 100%. However, FSEC researchers believe that humidities greater than 80% will be unsatisfactory within homes for reasons other than comfort. If relative humidity remains greater than 70% over a period of time, mold and mildew have a high

potential for formation and growth. Nevertheless, extensions of the optimal comfort lines for humidities below 20% and above 80% are shown as dashed lines on the charts.

**Figure 4**  
**Comfort Chart Developed by the Florida Solar Energy Center**

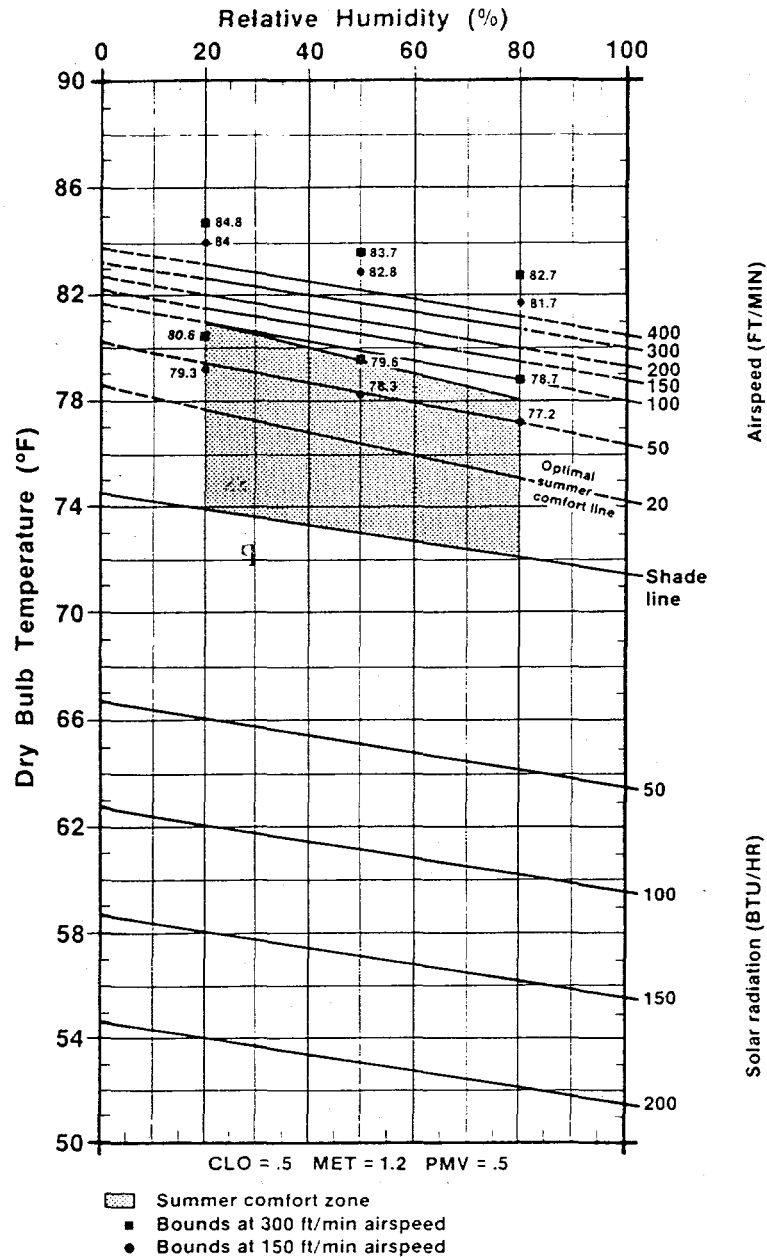

## Solar Motion

The movement of the sun through the sky is of critical importance to the solar designer. Solar motion has been explored and revered by man since his arrival on earth. Stonehenge in England, the early Indian dwellings of the southwest U.S., and numerous other physical manifestations of man's fascination with this phenomenon dot the globe. Yet modern man has all but forgotten the importance and inherent power of solar motion.

The apparent position of the sun in the sky is controlled by three factors:

- The time of day (solar time is different than standard or "local" time)
- The date of the year, and
- The latitude.

These three factors combine to place the sun at a different position in the sky at every hour of the half year. Its motion is symmetrical over the course of the year. In other words, with the exception of the summer and winter solstices, on any given day of the year there is one other day of the year when the path of the sun through the sky will be identical. Solar motion is also symmetrical about solar noon on any given day. The sun will be in the same relative position in the western hemisphere of the sky in the afternoon as it was in the eastern hemisphere in the morning.

In many latitudes, the sun rarely rises due east and rarely sets due west. With the exception of two days per year, it will rise either to the north or south of east and set to the north or south of west. In addition, the arc which the sun subtends in the sky will change from day to day. This change in sunpaths over the course of the year produces what has come to be known as the solar window. The solar window incorporates all the positions which the sun passes through between 9 a.m. and 3 p.m., solar time, over the course of the year.

The solar motion phenomenon provides a completely natural framework for the design of good buildings. It allows for the protection of the south face of buildings in summer and the exposure of that face in winter.

## Landscaping

Plants can provide much more than energy efficiency and comfort to building occupants, but this discussion will concentrate on the use of plants to improve the building thermal environment. One of the things landscaping can be used for is to control natural breezes and assist natural ventilation.

Dense planting on the north sides of buildings to deflect harsh winter winds is an historical example. With dense landscaping it is also possible to channel summer breezes and enhance building ventilation by creating natural "wingwalls" for buildings. The walls create high and low pressure zones on their opposing sides, redirecting airflows into building spaces and augmenting natural ventilation airflow by over 100% for the indicated wind directions.

Figure 5 illustrates both a correct and an incorrect plan incorporating the concept. Note that in the incorrect adaptation all the ventilation openings are in positive pressure zones while the alternative has openings in both positive and negative pressure zones. This results in pressure-driven cross-ventilation of the building. It should be noted, however, that landscape materials are not impermeable to airflow and will not produce equivalent effect to actual wingwalls.

**Figure 5**  
**Windbreaks to Promote Cross Ventilation (left). The Design at Right is Poor and Will Not Cross Ventilate**

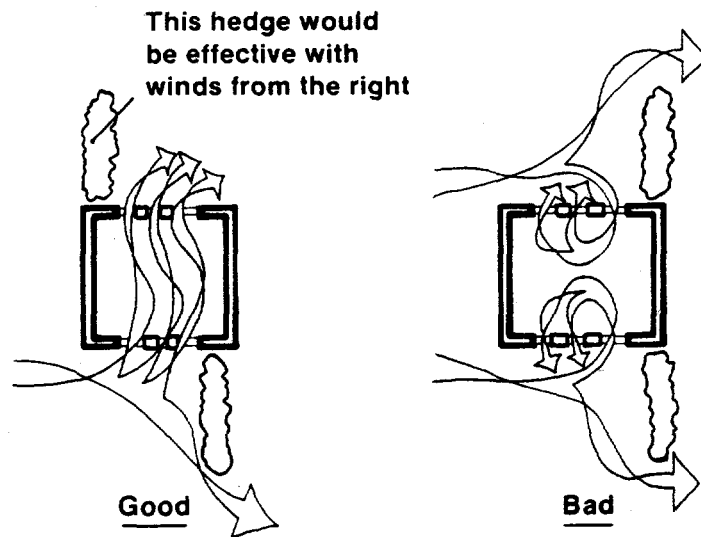

Shade and privacy are major attributes of plants. They can shade building faces (and sometimes even roofs) during periods of strong solar radiation. This results in cooler external surface temperatures and can significantly reduce heat flow into the building. It is also possible to use deciduous plants and vines to selectively shade buildings and exterior spaces. This can produce warm sunny winter spaces and cool shady summer spaces.

Plants also provide a natural cooling effect through evapo-transpiration. This process cools and humidifies the air adjacent to the plant. With a full tree canopy (forest) this can result in a much cooler ground environment. These cooler environment temperatures enhance the sensation of comfort.

Because the mean radiant temperature as well as the air temperature is reduced, the increase in comfort sensation is greater than for a simple reduction in air temperature.

## CHAPTER 3

### BUILDING COMPONENTS

#### Introduction

The interaction between heat transfer, building materials and insulation is one of the major considerations in good building design. A number of strategies are available and the success or failure of a building often rests on the manner in which materials, insulation, and building control strategies are brought together.

Two major categories of buildings exist today: lightweight frame construction and thermally massive concrete or concrete block construction. Both exhibit different responses to the exterior environment and if properly understood both can be effective building strategies. Generally, lightweight construction offers the advantage of very low building thermal capacitance (the ability to absorb and hold heat) but lacks the thermal leveling effect of massive construction. Massive construction, on the other hand, is capable of averaging daily temperature swings to provide more even interior temperatures over the course of the day. Its disadvantage lies in the fact that it loses heat slowly and, if not properly employed, may lead to elevated internal temperatures at night, making sleep quite difficult. With a comprehensive understanding of heat transfer mechanisms and building materials, the designer can produce buildings which take advantage of these characteristics to produce greater internal comfort throughout much of the year.

#### Insulation

Insulators are materials which are used to retard the flow of thermal energy. Most insulators are designed to restrict heat flow by conduction and are usually composed of materials containing large numbers of small trapped air pockets. The insulating value of the material is usually expressed in one of two ways — either as an R-value or as a U-value. The two values have a reciprocal relationship such that:

$$U = \frac{1}{R} \text{ and } R = \frac{1}{U}$$

The R-value is usually used to express the resistance of single thickness homogeneous materials. In composite building sections R-values may be added together to obtain the overall composite resistance of the building section. U-values on the other hand are not additive and composite U-values used in building load calculations must be obtained by adding together the various R-values and taking the reciprocal of the resulting summation.

$$U_{\text{comp}} = \frac{1}{R_1 + R_2 + \dots R_n}$$

Certain materials having low emissivities also function as retarders of heat flow when heat transfer is by radiation. In the classic sense these materials are generally classified as conductors rather than resistors because they are usually metallic and have very high conductivities. Foils made from gold, silver, and aluminum and other heavy metals fall within this class. When these materials are separated from other materials by an air space, heat flow by radiation is retarded. For certain directions of heat flow (i.e., heat flow down), radiation is the primary means of heat transmission and these products if properly employed can significantly reduce heat transfer. See next section on Radiant Barriers.

Tables 5 through 8 give R-values for various common building materials and configurations which can be used in heat transfer calculations.

In practice, additional resistances are introduced by the still air layer next to building surfaces. In R-value computations they are lumped together with the remaining conductive resistances.

**Table 5**  
**R-Values for Common Building Materials**

Type and Material		R
Building Board		
Asbestos cement	1/8 in.	0.03
	1/4 in.	0.06
Gypsum	3/8 in.	0.32
	1/2 in.	0.45
Plywood	1/4 in.	0.31
	3/8 in.	0.47

(continued)

	1/2 in.	0.62
	3/4 in.	0.93
Insulating board	25/32 in.	2.06
Regular	1/2 in.	1.32
Laminated paper	3/4 in.	1.50
Acoustic tile	1/2 in.	1.25
	3/4 in.	1.89
Hardboard	3/4 in.	0.92
Particle board	5/8 in.	0.82
Wood subfloor	3/4 in.	0.94
Masonry		
Concrete	6 in.	0.48
	8 in.	0.64
	10 in.	0.80
Concrete blocks		
3 oval core		
Sand & gravel	4 in.	0.71
	8 in.	1.11
	12 in.	1.28
Cinder	4 in.	1.11
	8 in.	1.72
	12 in.	1.89
Lightweight	4 in.	1.50
	8 in.	2.00
	12 in.	2.27
Concrete blocks		
2 rect. core		
Sand & gravel	8 in.	1.05
Lightweight	8 in.	2.18
Common brick	2 in.	0.40
	4 in.	0.80
Face brick	2 in.	0.22
	4 in.	0.44
Building paper		
15 # felt		0.06
Siding		
Asbestos cement		0.21
Wood shingles, 16 in.		0.87
Wood bevel, 1/2 x 8		0.81
Wood bevel, 3/4 x 10		1.05
Wood plywood, 3/8		0.59

(continued)

	Aluminum or steel	0.61
	Insulating board:	
	3/8 in. normal	1.82
	3/8 in. foiled	2.96
Finish Flooring		
	Carpet & fibrous pad	2.08
	Carpet & rubber pad	1.23
	Cork tile, 1/8 in.	0.28
	Terrazzo, 1 in.	0.08
	Tile, asphalt, linoleum, vinyl, rubber	0.05
	Hardwood	0.08
Insulation		
	Blanket and batt	
	2 to 2-3/4 in.	7.0
	3 to 3-1.2 in.	11.0
	5-1/4 to 6-1/2 in.	19.0
	Loose fill	
	Cellulose, per inch	3.7
	Sawdust, per inch	2.2
	Perlite, per inch	2.7
	Mineral fibre (rocks, slag, glass)	
	4-1/2 in.	13.0
	6-1/4 in.	19.0
	7-1/2 in.	24.0
	Vermiculite, per inch	2.2
Roof		
	Asphalt	0.44
	Wood	0.94
	3/8 in. built-up	0.33
	Woods: oak, maple per inch	0.91
	fir, pine, softwood per inch	1.25
	3/4 inch	0.94

*Note: When R-Values are given per inch, multiply thickness (inches) times to get total R.*

**Table 6**  
**R-Values for Air Films for Overall U Computations**

Position of surface	Direction of heat flow	<u>Surface Type</u>	
		non-reflective bldg. materials incl. glass	reflective aluminum surfaces
<b>A. INDOOR SURFACES (Still Air)</b>			
Horizontal	Down	0.92	2.70
Horizontal	Up	0.61	1.10
Vertical	Hor.	0.68	1.35
<b>B. OUTDOOR SURFACES (Summer Design Values)</b>			
Any Position	any direction	0.25	0.25

**Table 7**  
**R-Values for Air Spaces**

Position of Air space	Dir. of heat flow	1/2"Gap		3/4"Gap		1.5"Gap		3.5"Gap	
		NR.	REFL.	NR.	REFL.	NR.	REFL.	NR.	REFL.
Horizontal	Down	0.77	1.67	0.85	2.10	0.94	2.79	1.0	3.41
Horizontal	Up	0.73	1.51	0.75	1.61	0.77	1.71	0.80	1.83
Vertical	Hor.	0.77	1.67	0.84	2.08	0.87	2.25	0.85	2.15

*Notes:*

*The values for reflectives spaces are conservative.*

*Vented air spaces will have higher R-values.*

*Do not take credit for airfilm resistance in addition to these table values.*

**Table 8**  
**R-Values for Windows, Doors and Skylights Without Shades**

	<b>R-Value</b>
Single Glass Window/Patio Door	
Metal Frame	0.96
Wood Frame	1.2
Double Pane Glass/Window Patio Door	
1/4" Air Gap	
Metal Frame	1.6
Wood Frame	2.0
Skylights	
Single Wall Glass	1.2
Single Wall Plastic Dome	1.25
Door (wood) 1-3/4"	
Hollow Core	2.3
Solid Core	3.1
Door (steel w/polystyrene core) 1-3/4"	2.13

### **Radiant Barriers**

For the past eight years, researchers at the Florida Solar Energy Center have been studying the use of builders foil in attics. Tests have shown that when these products are installed with an airspace, called a radiant barrier system, they can be very effective in stopping heat transfer between a hot roof and conventional attic insulation. Research has also confirmed the importance of good ventilation in the attic from soffit and ridge vents if radiant barriers are to work effectively. It's also important to remember that radiant barriers are supplements to conventional insulation, not replacements, and should be part of your total building plans.

There are several types of radiant barrier foil on the market today, and you should look around to find the type which best fits your needs. Builders can choose from single-sided foil with kraft paper or other backing, double-sided foil with reinforcement between the foil layers, foil-laced insulation with some type of material to impede heat conduction, and multi-layered foil systems which form enclosed, insulating airspaces. Be sure to choose products which are labeled for radiant barrier use; some reflective or foil-covered building materials may not work properly when used as a radiant barrier.

As an alternative to the foil products listed above, builders can gain many of the benefits of radiant barriers by using a low-emissivity paint that can be applied directly to the underside of the roof decking. Tests have shown that though this paint is not as effective as the foil, it will reduce heat flow across the attic into the house, and can be very appropriate for many applications.

Installing radiant barriers in an attic is fairly easy during new construction. The experience of many builders has shown the importance of several basic guidelines.

- the radiant barrier must be installed so that there is an airspace next to the foil side of the material. The radiant barrier effect will not take place unless there is an airspace.
- the foil side should be facing down so that dust won't accumulate on the low-emissivity surface and weaken the system's performance. In addition, a gap of up to six inches should be left near the peak for hot attic air to exit the ridge vent.
- there are four locations where radiant barriers can be installed. They can be glued or stapled to the underside of the plywood roof sheathing (Figure 6), draped from roof rafters underneath the plywood (Figure 7), stapled from the bottom of the roof rafters (Figure 8)—with the foil facing down in all three of these cases—or placed on top of the insulation, foil side up. Laying the foil on top of the insulation is not recommended, since dust may accumulate over time and degrade performance. Some builders have found that the easiest and least costly installation method is simply to attach the radiant barrier to the roof sheathing.

A radiant barrier in the attic of the home can help improve both comfort and energy-efficiency. In conjunction with an airtight ceiling, light-colored roofing materials, attic vents, and well-installed insulation, a radiant barrier can be very effective in the Pacific Rim.

## Exterior Finishes

Exterior surface color and texture have a major effect on absorbed solar radiation. The solar absorptance (Greek lower case alpha,  $\alpha$ ) of a surface is the property that describes the degree to which a surface will convert incident solar radiation to thermal energy. A surface with an alpha of 1.0 would convert all the incident solar radiation to heat and a surface with alpha equal to zero would convert none.

Roof alpha typically ranges from about 0.5 for smooth white metal roofs to around 0.95 for black shingle roofs. White shingle roofs have an alpha between 0.70 and 0.75 and medium colored shingle roofs are between 0.80 and 0.90. Thus, the typical roof may easily convert 80 to 90% of the solar radiation that strikes it to heat. The other 10 to 20% is reflected. As a result, common dark shingle roof temperatures may climb 90 degrees F above the air temperature.

Wall alpha is also quite important, especially on east and west surfaces. Walls usually offer a more direct conductive path for heat transfer to the building interior than roofs. Common wall surfaces in full sunlight will be as much as 50 degrees F warmer than the air if they are dark ( $\alpha > 0.85$  dark stain on rough plywood). A light colored wall ( $\alpha = 0.5$ ) may only exceed air temperature by 25 to 30 degrees F under the same conditions; thus, the force driving the heat inward is reduced considerably.

For example, consider a peak case and let the air temperature be 90 degrees F. The dark wall would be 140 degrees F and the light wall would be 120 degrees F. The building interior temperature is 80 degrees F so the temperature differences ( $\Delta T$ ) across the two walls are 60 degrees and 40 degrees F, respectively. Given the same insulation, the reduction in wall heat transfer due to the lighter color will equal the reduction in  $\Delta T$  and is 33%. Thus, the choice of exterior surface color and finish can have a major impact on the heat gain through the building envelope.

Other considerations are also often important. Consider a very smooth white surface with an alpha value of 0.5. Its reflectance will also be 0.5. If this surface is reflecting 50% of the incident sunlight into a window, then the light colored surface is counter-productive unless more daylight is needed.

Likewise, a reduction in alpha changes the winter performance of building components and may result in greater heat loss (or less gain) during sunny winter days. This is not a significant consideration in the Pacific Rim countries.

Table 9 gives some typical alpha values for common building materials and surface finishes. Reflectivity equals one minus the alpha value.

Figure 6  
Attaching the Radiant Barrier Directly to the Sheathing Can Reduce Installation Costs

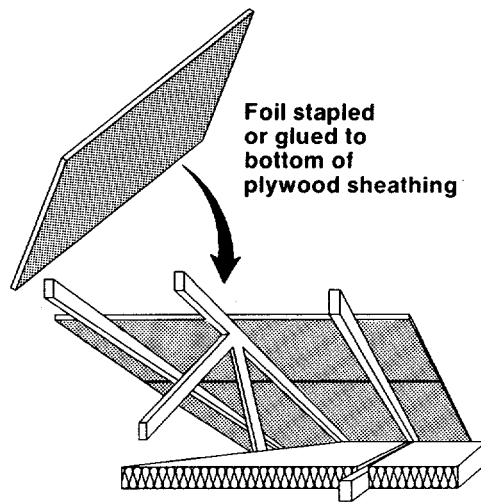

Figure 7  
A Radiant Barrier Can Be Draped Over the Trusses With Foil Facing Down

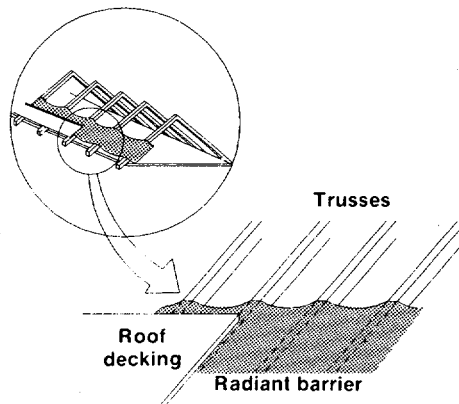
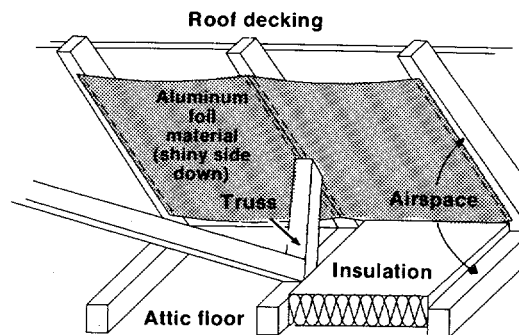

Figure 8  
A Radiant Barrier Can Also be Installed By Stapling it to the Bottom of the Trusses



**Table 9**  
**Effective Solar Absorptance ( $\alpha$ ) and Reflectance**  
**of Some Common Building Surfaces**

Surface	Solar Absorptance	Solar Reflectance
<b>Asphalt shingles</b>		
dark	.90 - .98	.02 - .10
medium	.80 - .90	.10 - .20
white	.70 - .80	.20 - .30
<b>Built up roofs</b>		
dark pebbles	.90 - .98	.02 - .10
medium pebbles	.80 - .90	.10 - .20
white pebbles	.65 - .75	.25 - .35
<b>Roof tile (unglazed)</b>		
dark	.85 - .95	.05 - .15
medium	.70 - .85	.15 - .30
white	.50 - .65	.30 - .40
<b>Cedar shakes (or raw wood surfaces)</b>		
old	.80 - .85	.15 - .20
new	.65 - .75	.25 - .35
<b>Rough wood surfaces (painted or stained)</b>		
dark paint	.90 - .98	.02 - .10
medium paint	.75 - .85	.15 - .25
white paint	.55 - .65	.35 - .45
<b>Smooth wood surfaces (painted or stained)</b>		
dark	.85 - .95	.05 - .15
medium	.75 - .85	.15 - .25
white	.45 - .55	.45 - .55
<b>Glazed or enamel surfaces</b>		
dark	.80 - .95	.05 - .20
medium	.65 - .80	.20 - .35
white	.30 - .45	.55 - .70

(continued)

Stucco			
	dark	.85 - .95	.05 - .15
	medium	.70 - .80	.20 - .30
	white	.45 - .55	.45 - .55
Brick (unpainted)			
	dark	.80 - .90	.10 - .20
	medium	.70 - .80	.20 - .30
	white	.60 - .70	.30 - .40
Concrete block			
	dark painted	.90 - .98	.02 - .10
	medium painted	.70 - .85	.15 - .30
	white painted	.50 - .60	.40 - .50
	unpainted	.75 - .80	.20 - .25

*Notes:*

- |                  |   |  |
|------------------|---|--|
| 1. <i>Dark</i>   | - | <i>Black and dark primary color blends</i> |
| 2. <i>Medium</i> | - | <i>Pastel to warm primary color blends</i> |
| 3. <i>White</i>  | - | <i>No primary colors or black</i>          |

## Window Design

Although necessary for aesthetics and fire egress, windows are a thermal liability in the summer since they permit solar gain and have low R-value. The only positive energy aspect of windows in hot climates is that they permit natural ventilation.

Different residential window types are shown in Figure 9. Since fixed glass contributes nothing to natural ventilation, we recommend use of awning, projection, or casement windows. The jalousie type is not recommended for air conditioned areas as it leaks and causes excessive infiltration when closed. Any window in an air-conditioned area should have good weatherstripping and be constructed to minimize infiltration. For rain protection and minimum building protrusion we recommend awning or projection windows over casement windows. Fire egress requirements and wingwall considerations, however, may dictate a casement window in some rooms.

Figure 9  
Window Types

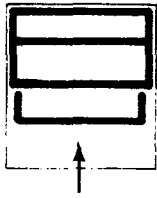

Single-hung

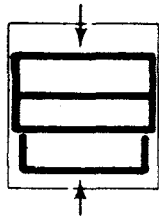

Double-hung

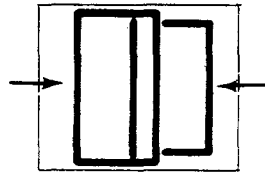

Horizontal sliding

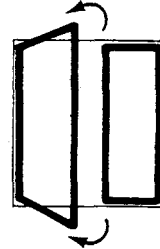

Casement

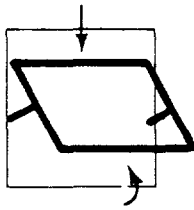

Projection

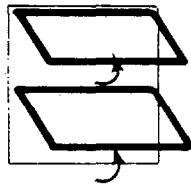

Awning

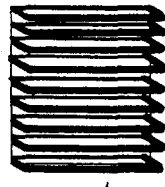

Jalousie

## CHAPTER 4

### NATURAL VENTILATION

#### Good Ventilation

There are many times during the year in the Pacific Rim countries when outside temperatures are quite comfortable but closed buildings require air conditioning because of internal and solar gains. Direct solar (through windows) and internally generated heat gains will account for half of the air-conditioning load in most hot climates. Thus, if outside air conditions are comfortable, the building can often be made comfortable through ventilation. Depending on climate and building type, ventilation can save up to 50% of the annual air-conditioning requirement as compared to a closed building in warm climates.

The most effective natural ventilation of buildings occurs when air inlets are pressurized (have a positive pressure with respect to the room air) and outlets are depressurized. Pressure differences across buildings are created by the wind. Windward surfaces generally have a positive relative pressure. Leeward surfaces and areas where the airflow is split away from the building surface by sharp edges (flow separation) generally have negative relative pressures.

**Figure 10**  
**Idealized Airflow Patterns Through and Around a Simple Cross Ventilated Single Room Building**

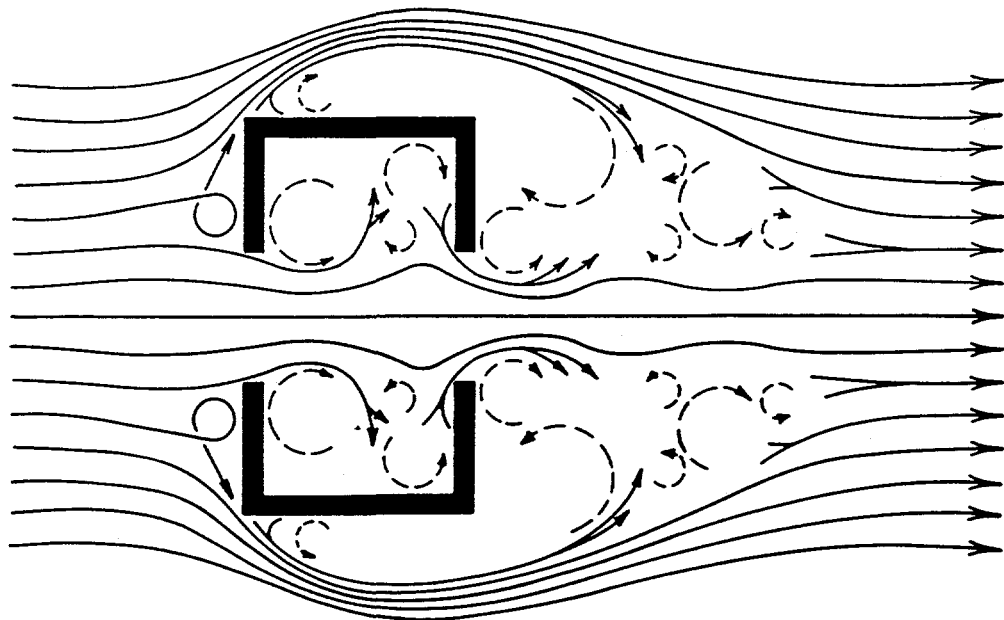

Figure 10 presents idealized airflow patterns when a building is cross ventilated. Far greater turbulence than can be presented in the figure occurs in reality but airflow will often follow logical flow paths. Following are some basic principles of airflow:

- Air has a negligible viscosity but exhibits significant inertia. Thus, streams of air can “slip by” one another or a surface to form flow streams, but moving air does not like sharp turns.
- Faster moving flow streams have reduced relative air pressures and “entrain” air from slower moving air, dissipating the energy of the faster flow stream.
- Smooth surfaces “attract” parallel airflow in order to reduce energy dissipation due to air entrainment. This attached flow phenomena is often called the “wall effect” and can be effectively used in some building ventilation strategies.
- Inertia causes airflow separation at windward, sharp corners of bodies in the wind. This results in significantly reduced air pressures and causes turbulent recirculating airflow eddies, consuming significant amounts of flow field energy through the dissipation of the air’s inertial energy. Of the available shapes, tear drops produce the least turbulence in a uniform airflow field (tail to leeward). Airflow remains attached over the entire surface and aerodynamic resistance to airflow is minimized.

Figure 11 illustrates the above principles in a five-room building. Airflow in the figure is idealized but illustrates airflow behavior patterns relatively well. Room A represents a directly cross-ventilated space and has excellent airflow. Due to inertia, however, a large amount of the air passes directly through the room in the form of a “jet.” Entrainment of the slowly moving room air by this jet induces a recirculating airflow in the remainder of the room resulting in relatively well mixed room air.

Room B illustrates two airflow phenomena. First, the substantial negative pressures caused by flow separation at the building corner produces substantial airflow through the room. But the wall effect causes much of the flow to attach itself to the wall surface. As a result, heat transfer at this wall surface will be augmented but room air mixing will be reduced. If the outlet window is moved closer to the windward building corner, both the suction pressure at the outlet window and room air mixing would be heightened, resulting in slightly better ventilation.

**Figure 11**  
**Illustration of Airflow Through and Around a Five Room Building**

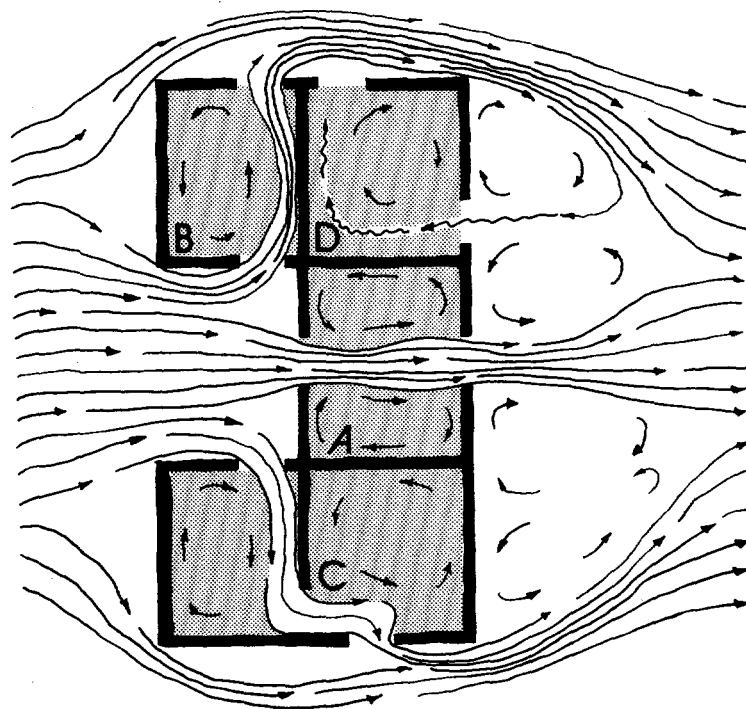

Room C is not nearly as well ventilated as A and B. Typically, only the wall surface is well vented. Some air entrainment and mixing can be expected on the windward side of the partition but due to the outlet location the air on the leeward side of the partition will almost be still with very little recirculating flow. The outlet is also located at a relatively weak negative pressure zone. It is far enough away from the windward building corner so that the airflow has almost reattached itself to the wall. This results in less pressure difference between inlet and outlet and therefore less total airflow than in room B.

Room D has both of its openings located in negative relative pressure zones and is very poorly ventilated. Only very minor recirculating flows exist in the room because pressure differences between the two openings are almost negligible. Note, however, that the sidewall window still has a slightly lower pressure than the window on the leeward face and the figure shows the leeward window as an inlet.

Obviously, as wind directions change, so do ventilation potentials. If the wind direction were reversed in Figure 11, rooms A and D would ventilate well. Room B may not ventilate at all and room C would have only minor recirculating flows induced by flow separation at the windward corner.

This example is idealized because it incorporates an isolated building in the wind. Buildings are usually located in groups. If building groupings are not carefully planned, the buildings will be in each other's airflow "wakes" and ventilation potential in the leeward building will be greatly reduced.

Typical single story buildings have wakes that extend roughly four to five times the ground-to-eave height of the building, or about 30 to 50 feet to the leeward side.

### Ventilation Augmentation by Wingwalls

Many residences and large buildings have rooms with only one external wall. These rooms are difficult to ventilate effectively. With one window in such a room, ventilation will be negligible even if the wind impinges directly on the window, since there are no distinct inlets and outlets. Ventilation can be improved somewhat if two windows are used, placed as far apart as possible. Ever-present fluctuations in the natural wind direction will create moderate amounts of pressure difference across the two windows, particularly if the wind direction is perpendicular to the windows (Figure 12).

**Figure 12**  
**Two Windows Ventilate Better Than One in Rooms With One Outside Wall**

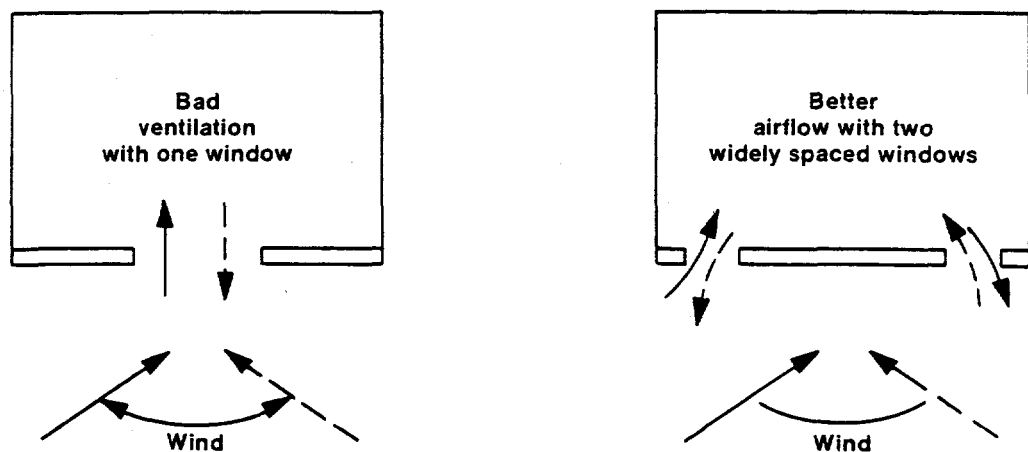

Airflow in rooms with two windows can be further augmented by devices called wingwalls that are added to the building's exterior at the inner edges of the window. These create positive pressure over one window and negative over the other, achieving cross ventilation of the room (Figure 13). Wingwalls should extend from the ground to the eaves. However, properly placed single-sash casement windows can create a similar effect. Wind directions for which wingwalls are effective are also shown in Figure 13.

**Figure 13**  
**Good Ventilation Through Windows on One Wall When Wingwalls are Added**

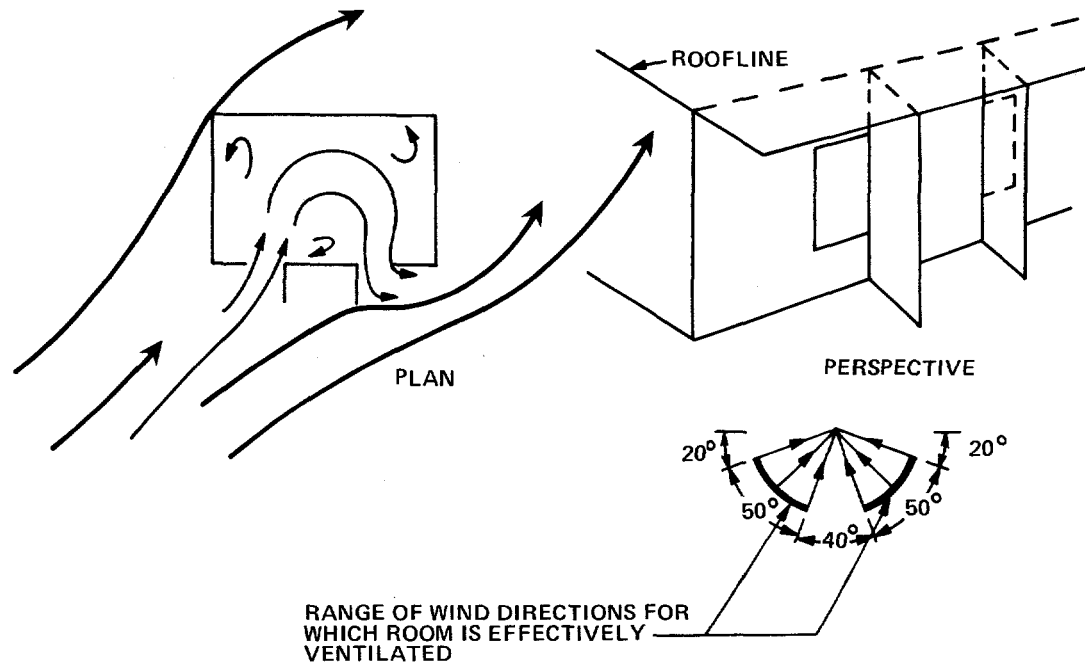

Note that wingwalls are effective only for windward windows; they will not affect airflow at windows on the leeward side.

### Design Strategies Using Wingwalls

When ventilating rooms with various wingwall strategies, effectiveness is limited to wind directions that cause one window to be in a positive-pressure zone and the other to be in a negative-pressure zone. Thus, a single window will not work.

Figure 14 shows expected ventilation results for a number of wingwall configurations or patterns, all drawn for southwest winds only. Actual wind directions for which wingwalls would be effective are shown by wind-direction band. In some cases the best strategy is very difficult to define, and windows and their wingwalls must be specifically placed to take advantage of a given site condition. For example, pattern #7a would prove to be an excellent, if not the best, design decision where alternating northwest and southeast breeze patterns occur (e.g., a land breeze by night and a sea breeze by day) as indicated by the wind-direction band. On the other hand, if this pattern is adopted for a predominant southwest wind direction, it will be a design failure. Pattern #7b is considered to be poor

in all wind directions because of extensive short circuiting caused by the close proximity of the windows. Airflow will occur only through that very small corner of the room.

**Figure 14**  
**Wingwall Design Patterns for Two Windows on the Same or Adjacent Walls**  
**Showing Probable Air Flow Patterns for Southwest Winds and Wind**  
**Directions for Improved Ventilation Performance Due to Wingwalls**

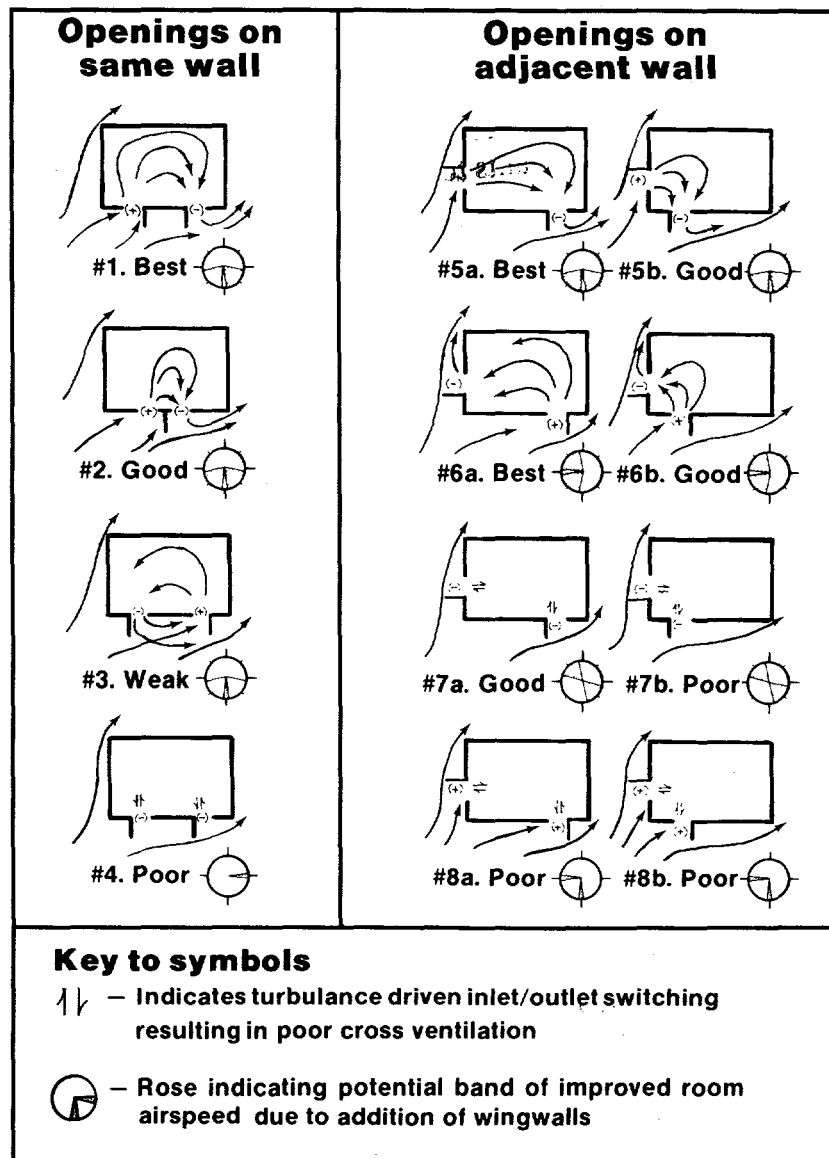

Wingwall examples

These patterns also illustrate the benefit in overall room airflow gained through the window separation (#5 and #6, a versus b, and #1 versus #2). However, pattern #2 is helpful in situations where rows of small rooms allow only single-sided ventilation in double-loaded corridor designs. For larger rooms, where spacing permits, pattern #1 should be used. Wingwalls can become significant elements of design and unity in such buildings.

In general, wingwall protrusions should be equal to open window width. However, protrusions equal to half window width also will work well. Figure 15 provides recommended dimensions and minimum separation distances between multiple sets of wingwalls. No minimums are given for window placement with respect to internal partition walls since these would depend on the desired cooling strategy (i.e., whether one wants to cool the partition wall or wants to direct airflow into the room).

**Figure 15**  
**Recommended Wingwall Dimensions and Separations**

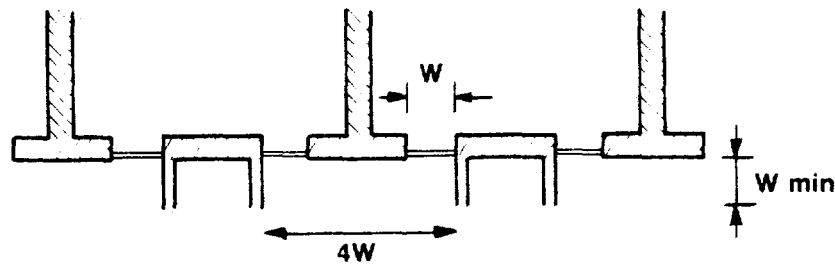

### Trees and Landscaping to Channel the Winds

Strategically placed dense trees on the east and west sides of a house can effectively block the summer sun. Vegetation, however, can also reduce air flow. Airspeed reduction can be 30 to 40 percent near a tree depending on canopy size. Architectural drawings occasionally show shrubbery or trees redirecting or catching the wind in a manner similar to the wingwall effect discussed earlier. Fencing or dense shrubs may accomplish this, but field data substantiating this effect are not available. Shrubby effectiveness is reduced by a leaf's tendency to bend and align itself with the wind instead of serving as a stiff redirecting barrier. Solid fencing or walls are recommended rather than trees or shrubs for redirecting winds.

Proper planting of trees can be effective as a community strategy. For example, older parts of St. Augustine, Florida are very effectively shaded by tall spreading trees. The trees allow breezes to pass at the first three stories while providing shade to these lower building levels and to pedestrian walkways.

### Airflow on Roofs and Whole-House Roof Ventilators

Due to compact floor plans and internal walls, modern houses are often difficult to cross ventilate. In some situations roof apertures may be useful. Note that we here discuss whole-house ventilation through roof apertures and not attic ventilation.

**Figure 16**  
**Flow Past a Building (Side Elevation) with a 5 in 12 Roof Pitch (Flow Pattern Will Be Similar for Any Roof Pitch Greater Than 3 in 12)**

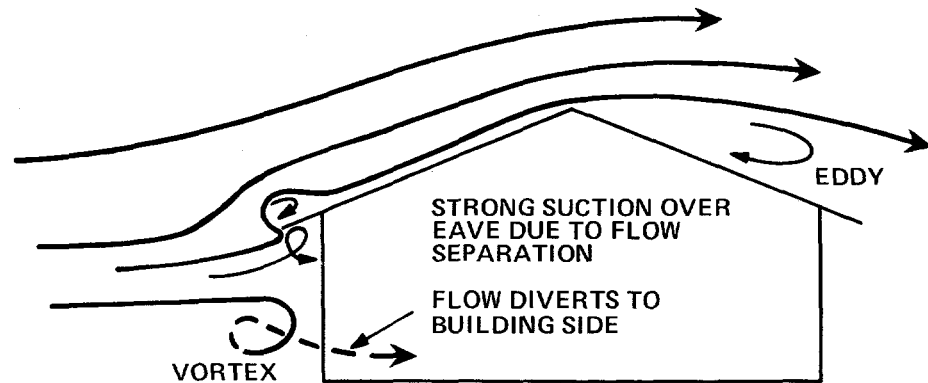
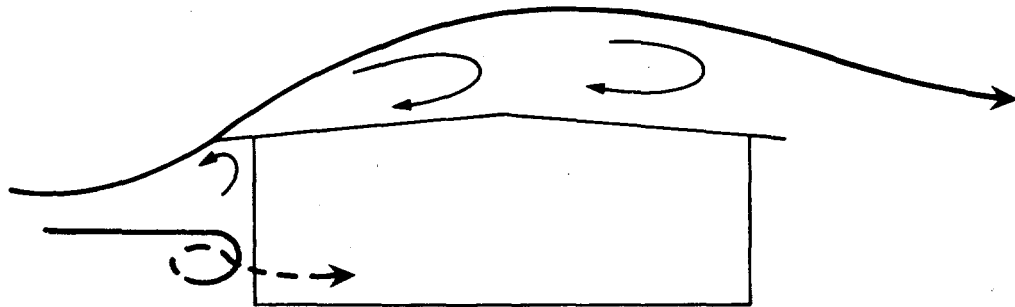

Figure 16 shows the airflow pattern, in elevation, past a building with no apertures. The high-pressure region on the windward face creates two flows. A downward vortex is created near the ground which produces airflow away from the building. The upper half of the flow goes over the roof. The upward flow separates at the roof edge and creates a strong negative pressure on the eaves. Flow, however, remains attached over most portions of the windward roof and separates again at the roof peak. For flat or low-pitch roofs (2 in 12 or less) flow may remain separated over the entire roof (Figure 17).

**Figure 17**  
**Flow Past a Solid Building with Roof Pitch Less Than 2 in 12 (Note That The**  
**Airflow is Separated Over the Entire Roof)**



Areas of strong negative pressure created on the roof top, especially those near roof ridges, can be used as exhaust areas (Figure 18). The top 18 inches of partition wall in the living space are louvered to allow airflow. Even without a roof-level aperture these louvers can improve ventilation at the expense of some acoustical privacy. In this design, room A will ventilate as shown. Due to strong roof suction, the window in room B may occasionally be an inlet (broken arrow), although most of the time it will be an outlet (solid arrow). The exhaust space above ceiling level is likely to act as an exhaust at all times. Since roof cupolas are difficult to protect against rainstorms, operable windows are shown in the cupola. Opening and closing of such windows are difficult. Louvers and similar devices at the cupola will not protect against severe rainstorms and consequently are not recommended. In this design, wind-driven ventilation will act with the rise of hot air since outlets are at the top.

**Figure 18**  
**Whole House Ventilation Through Roof Level Outlet Windows and Low**  
**Inlet Windows (Dotted Arrows Show Alternate Possible Flow Path)**

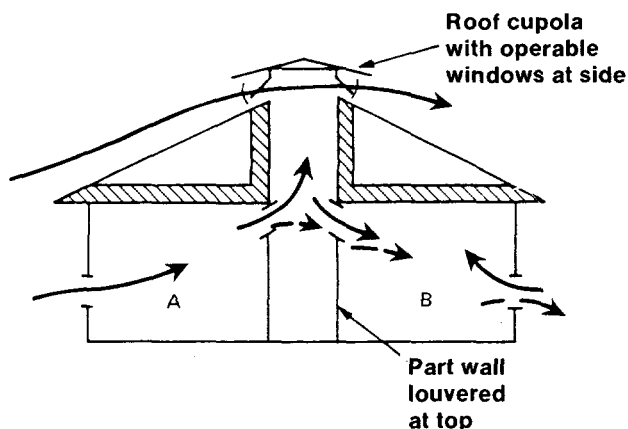

Another possible type of high-level vent is a clerestory window (Figure 19). When winds are from the left, the design will ventilate as shown by the solid arrows; the wind effect helps the chimney effect. However, if winds are from the right, clerestory windows will act as inlets and room windows as outlets; daytime hot air adjacent to the roof may be forced into the house. Thus, single-sided clerestory ventilation may not be very effective in all situations.

**Figure 19**  
**Whole House Ventilation Through Clerestory Windows**

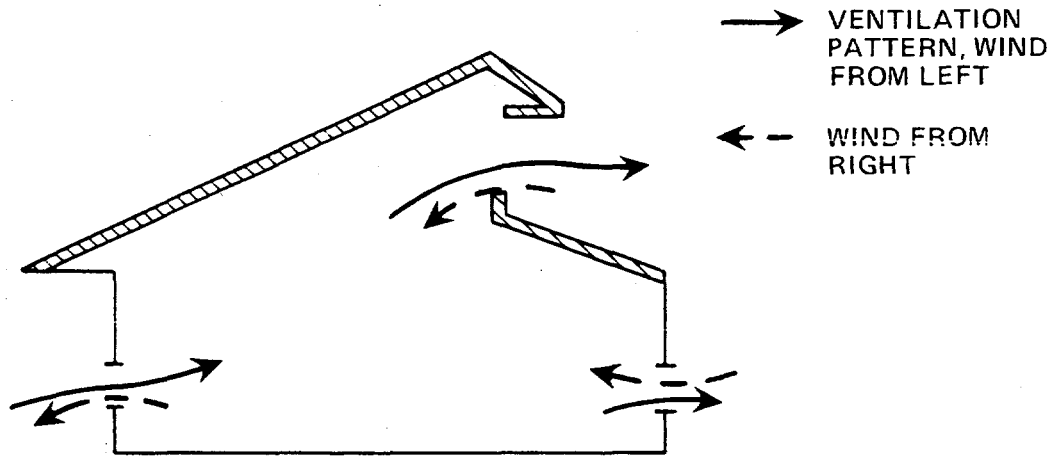

### Room Ventilation Strategies

Room locations can be categorized as one of six types (Figure 20). Shape and exact position may vary, but rooms will typically have either 0, 1, or 2 exterior walls and be either on the windward or leeward side or in the building interior. The three generic windward rooms will cross ventilate even with the interior door closed (Figure 21).

**Figure 20**  
**Room Location Categories With Respect to Prevailing Winds**

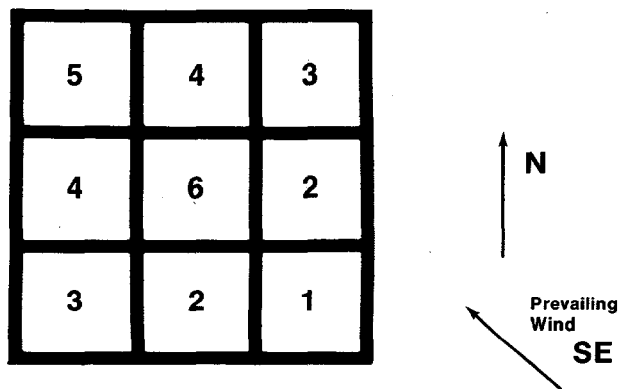

**Figure 21**  
**Strategies for Ventilating Windward Rooms for Southeasterly Winds**

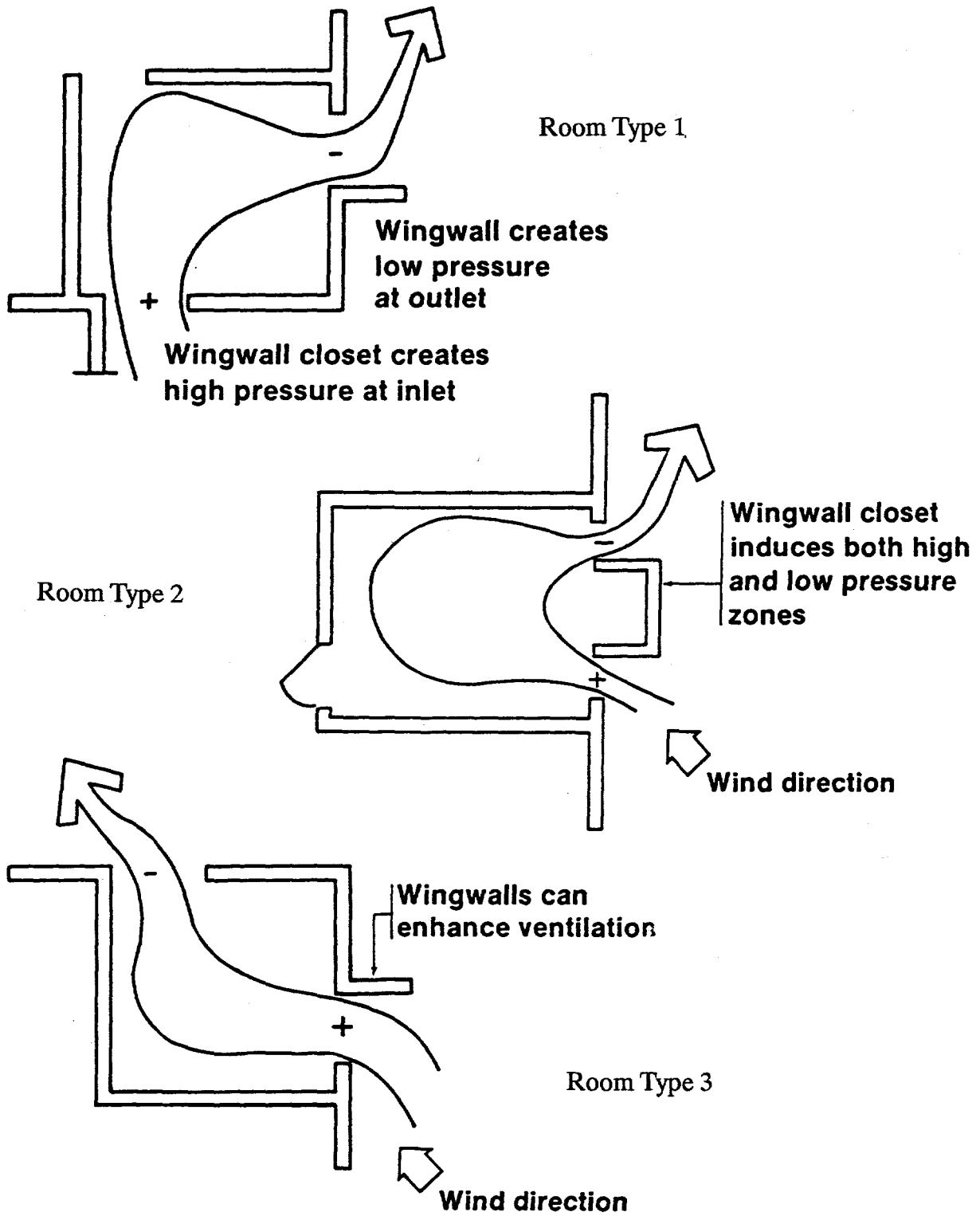

Wingwalls or properly located casement windows are crucial to the success of these designs and are suggested for room type 1 with prevailing southeast winds. An optional wingwall to enhance ventilation is suggested for room type 3, but the room will ventilate fairly well for southeast winds and quite well for east winds without a wingwall.

The area between two adjacent wingwalls can become a closet or space for a bed headboard or a sofa, and wingwall construction and exterior surface materials can be highly varied. A designer can vary detailing and create new versions of the wingwall/window relationship so long as the basic principles are not violated.

For leeward room locations, interior doors and wall vents are required to provide adequate ventilation. Even then, ventilation will be poorer than that for windward rooms. Cross ventilation without wingwalls can be used when the building has a room (or space) which is open from front to back or to the sides of the house. A screen door at the entry can frequently cross ventilate the living area.

### **Example House Plans**

Five home plans designed for 75-foot-wide lots are presented. These illustrate applications of airflow principles to practical designs for small homes. Details of wall and roof construction and of insulation levels are not given. Homes have been designed for prevailing east-southeast and southeast winds. Wind directions for which the designs are most effective are shown in each figure. The first four plans, each with 1334 square feet of floor area, are actually the same design rotated to correspond to particular lot orientations and to demonstrate the capability of one design to satisfy ventilation needs independent of lot orientation.

**Figure 22**  
**A House Plan for South-Facing Lots**

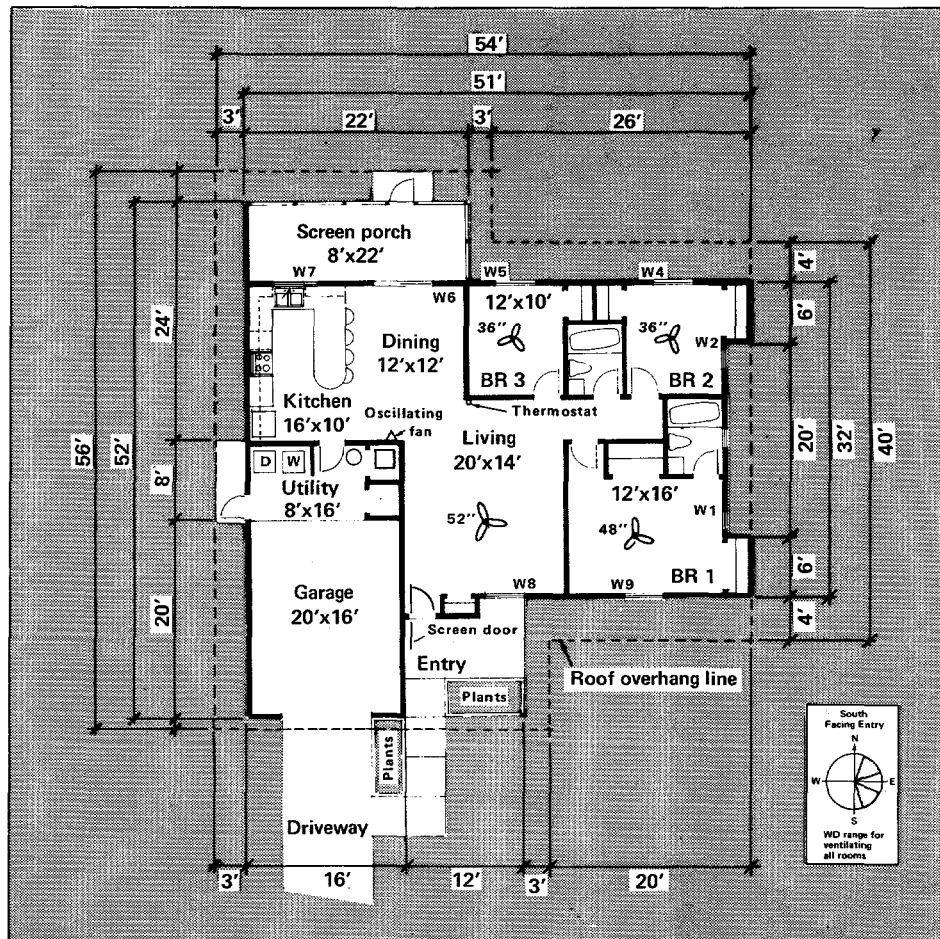
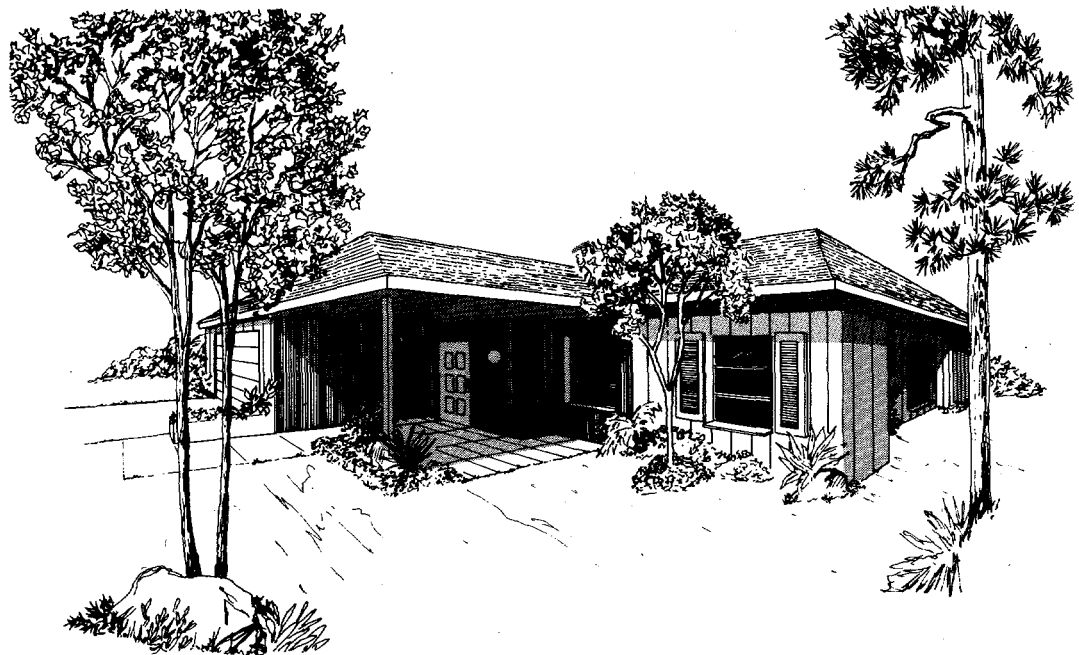

Figure 22 shows the floor plan for a south-facing lot. Solar gain from the west is minimized by not using windows. The garage east wall acts as a wingwall to deflect southeast winds into the house; the solid west wall of the screened porch serves a similar function for northeast wind. Closets in BR1 and BR2 are designed to act as wingwalls also. The wingwall in BR1 creates a negative pressure on window 1 (W1) and makes it an exhaust, and the wingwall next to W2 makes it an inlet. BR3 cannot be directly cross ventilated; the door must be left open to cross ventilate.

If the door is closed, ventilation through the kitchen can be further improved. Arrows in windows indicate natural airflow patterns likely for southeast winds with all internal doors closed (except for the BR3 door). A screen door at the entrance and opening of other doors further improves cross ventilation.

The perspective view (Figure 23) clarifies roof lines. The screened-porch roof (not shown) is an integral part of the whole roof. Outdoor model tests of this design show that it ventilates quite well for all wind directions due to the many protrusions which help induce positive and negative pressure zones as natural wind direction fluctuate randomly.

**Figure 23**  
**A Perspective of the Home in Figure 22**



Ceiling fans are used in many rooms. A wall-mounted oscillating fan is proposed to induce air motion in kitchen and dining areas. The kitchen range should have an exhaust fan vented to the outside through a roof vent, and bathrooms should have individual exhaust vents. The thermostat for the heating-cooling unit should be located on an inside wall rather than on a wall to the garage for better comfort and less frequent adjustment. Heating and cooling ducts should run in the conditioned area rather than in the attic. The wall between the garage and the conditioned space should be insulated.

A reverse image of the floor plan is used for a north-facing lot (Figure 24). An important feature is the solid west wall of the screened porch which deflects a southeast wind into the house.

Awning windows are recommended for all windows in all plans. They should be of good quality that seal well when closed. Awning windows are recommended over horizontal or vertical sliding windows for better rain protection and to maximize open-window area for a given glass area. This house will require a total operable screened window area equal to 12% of the floor area, or 160 sq. ft. A sliding glass door and an entry door provide 21 sq. ft. each. The remaining 118 sq. ft. are provided by windows.

**Figure 24**  
**A House Plan for North-Facing Lots**

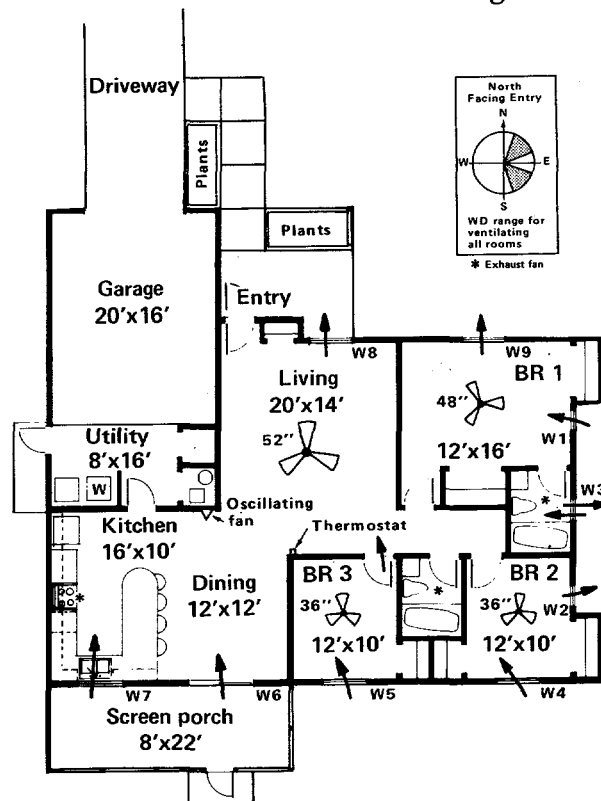

Recommended window sizes and vertical placements in the wall are shown in Figure 25. Windows near the wingwall should be vertical to minimize wingwall protrusion from the building.

**Figure 25**  
**Recommended Window Types and Sizes**

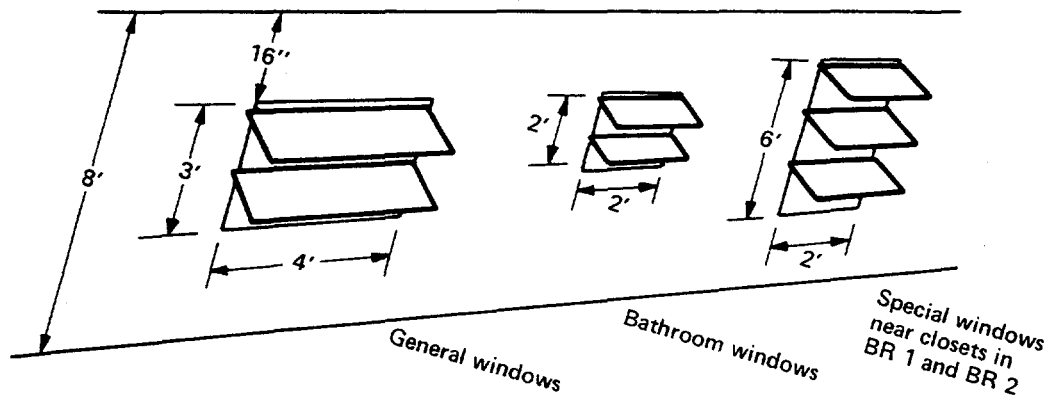

In these designs, windows on the east or west side are required for good ventilation, but they must be protected from the sun in the morning or afternoon, respectively. At a minimum they should have reflective film, but do not use such film on double-paned glass. An aluminized reflective roller shade, which can be kept up in winter to allow sunlight into the house, is better yet. The best heat-gain prevention scheme for east or west windows is exterior operable awnings, shutters, or sun screens (Figure 26).

**Figure 26**  
**Shading Strategies for East or West Windows**

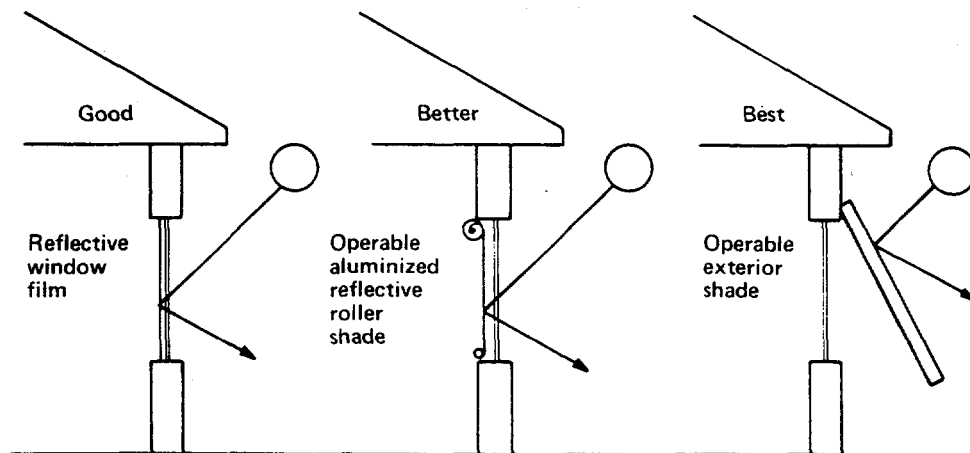

Large overhangs are another solution, and shade trees on the east and west sides would also be excellent.

The south-facing plan, rotated 90 degrees, is used for a west-facing lot (Figure 27). Wingwalls located on the south wall work on the same principle as before (Figure 22). BR1 is ventilated by the wingwall at W1, BR2 is ventilated by W4 and the wingwall at W2, and BR3 is ventilated by leaving the door to the hallway open.

**Figure 27**  
**A House Plan for West-Facing Lots**

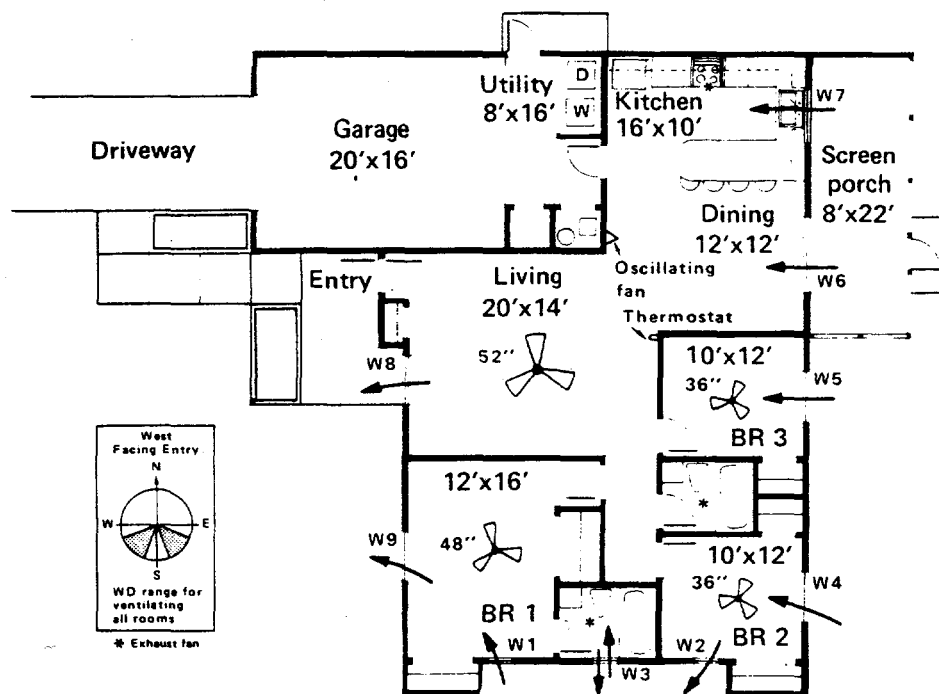

Another small (1,360 square feet) home design for west-facing lots (Figure 28) has better west sun protection and does not require west windows. The master bedroom is ventilated by a French door or by a large casement window (W1) augmented by the dressing-room wall and the leeward window W9. Wingwalls are integrated into closets in bedrooms 2 and 3. The second bedroom is ventilated by windows on both external walls, with a wingwall on W4 to make that window an outlet. A wingwall is not provided on W3 as it would block ventilation for northeast winds. In this design all three bedrooms are cross ventilated for southeast winds.

**Figure 28**  
**A Design for West Facing Lots**

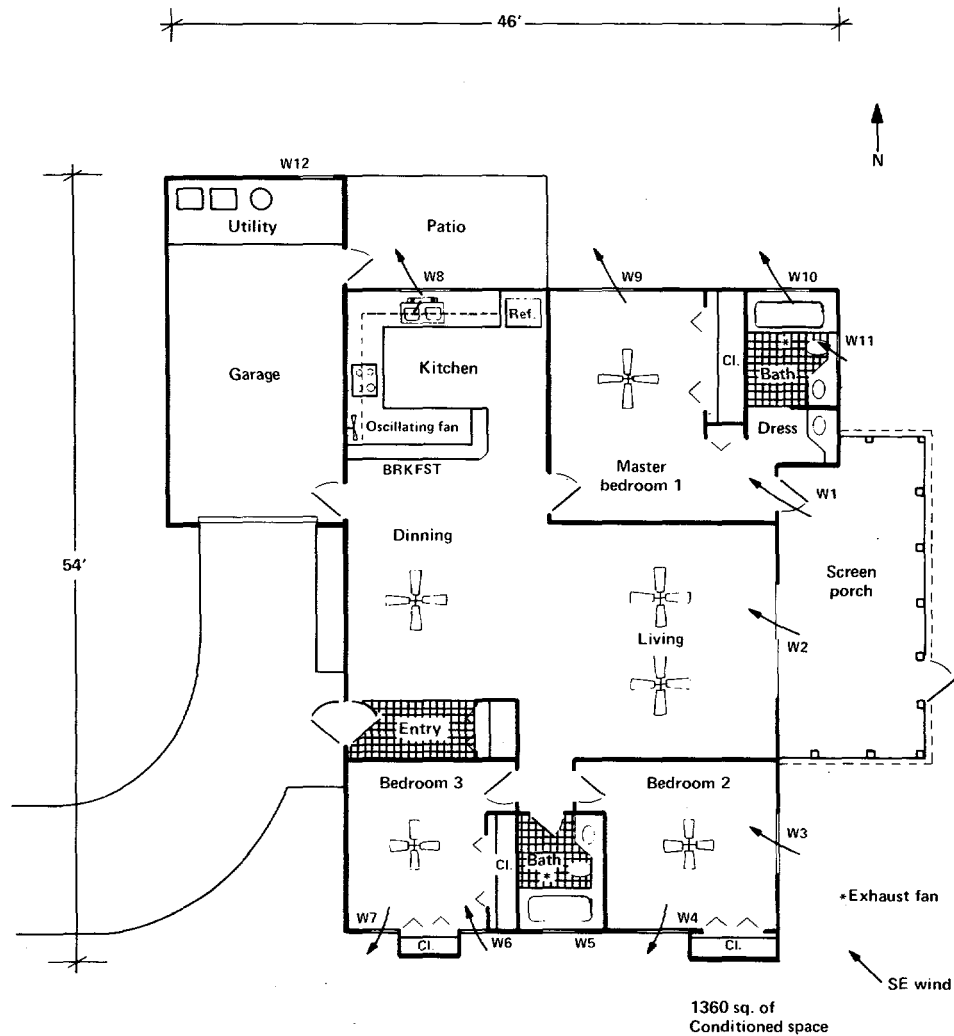

The north-facing plan, rotated 90 degrees, is used for east-facing lots (Figure 29). The garage acts as a wingwall to direct airflow into the building by creating a high-pressure zone on the east wall.

### Internal Loads

Internally generated heat and moisture loads can account for well over one third of the load on air-conditioned buildings. One third of this comes directly from the occupants and cannot be reduced. Most of the rest comes from appliances, lighting and activities like cooking, cleaning and bathing. Many of these internal loads may be partially eliminated through controlled exhaust vents. This, of course, requires make-up air from the outside. If ceilings are not tightly sealed at electrical and plumbing system penetrations this make-up air may come from the attic. This is highly inadvisable during the day. It is

far better that it come through the minor cracks around windows and doors. Since vent fans will under-pressurize the building somewhat, minor infiltration will occur at these seals. Thus, the provision of fresh air to the building also serves to vent some of the internally generated heat and moisture loads. Maximum advantage of controlled infiltration can be attained by using vent systems with good dampers that close tightly when fans are not operating. If the vent fans are not operating, a tight building will have very little infiltration. Controlled ventilation for health, then, can be matched to building occupancy patterns.

**Figure 29**  
**A House Plan for East-Facing Lots**

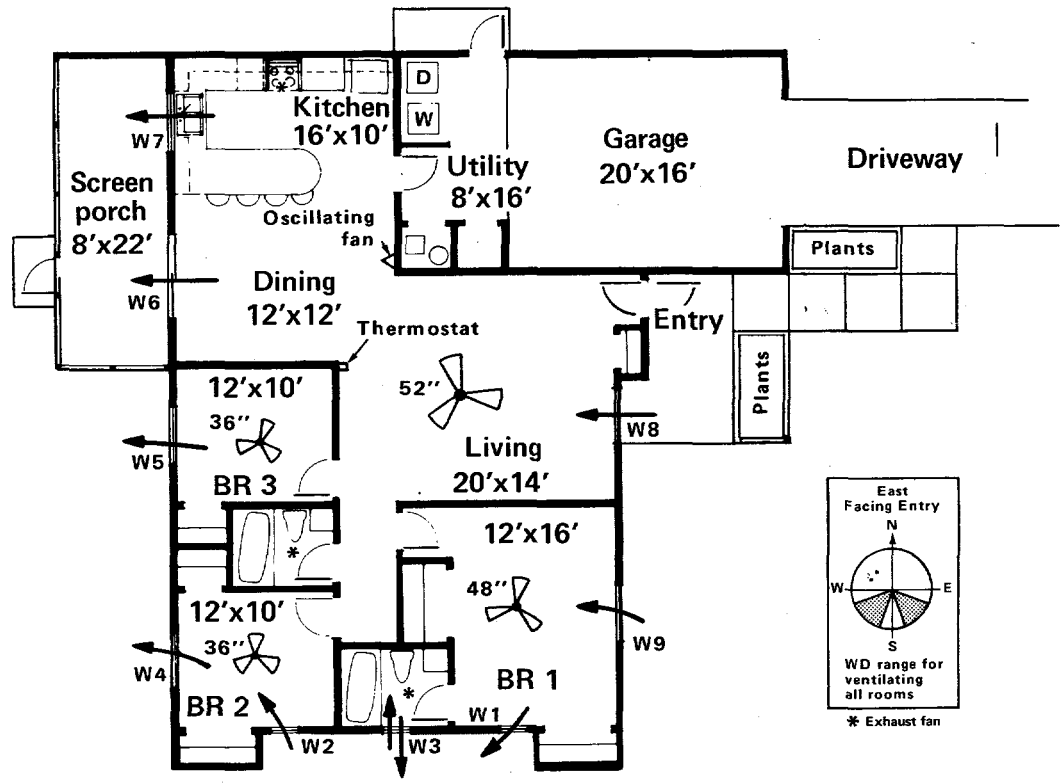

The kitchen is the greatest heat producer in a residence. The refrigerator is a constant source of heat. Cooking, dishwashing, and occupancy produce moisture, heat, and pollutants. Controlled ventilation should be greatest in the kitchen. Bathroom ventilation should generally be more intermittent and less powerful. Only about 0.5 air changes per hour (ach) are required for a healthy environment during full occupancy. Controlled exhaust systems can be sized and balanced so as not to exceed this figure by too much. Combining building tightness techniques with controlled ventilation techniques has the potential of large savings since both infiltration and internal generation loads are reduced.

Many occupancy loads need not occur in the conditioned space. Clothes washers and dryers and water heaters need not be inside the home. Utility rooms that are insulated from the conditioned space and separately vented to the outside are much preferred locations for these appliances in hot climates. Such climates can also take maximum advantage of the modern "summer kitchen" — the Bar-B-Que grill. Outdoor cooking removes the cooking load from the building and is a very pleasant activity.

This is one reason why multifamily building designs for hot climates like the Pacific Rim should be well integrated with the outdoors.

## CHAPTER 5

### Introduction

Air conditioners cool the air and can dehumidify indoor spaces. The dehumidification ability of an air conditioner is the main reason why many people choose to run air conditioners at nighttime to get a good night's sleep during the summer months.

It is important to realize, however, that air conditioners run on a thermostat which senses only temperature and not humidity. Thus, in good buildings — those which incorporate proper orientation, window shading and radiant barriers — it becomes all the more important to control the entry and generation of humidity in the first place to get maximum benefit from an air conditioner. If the moisture load increases, the air conditioner may not be able to keep up with it, so indoor humidity may rise. To reduce it, the thermostat has to be turned down so the a/c runs longer. This wastes energy and produces “too cold” an atmosphere. The moisture loading in an air conditioned building comes largely (about 80%) from infiltration of outside air and only 20% or so from internal cooking, people, showering, etc. Thus, infiltration control steps should be a major consideration in an air-conditioned house. Some of these are:

- Use kitchen and bathroom vent fans which have a damper on the outlet.
- Carefully seal behind electrical outlets so that there is little air exchange between the attic and the house. Seal penetrations from attic into the house.
- Use windows and doors which have good weatherstripping. Caulk window and door frames periodically as necessary during the life of a house.
- If only one or two rooms of a house are to be air conditioned, then place the rooms on the leeward side of the house to minimize wind driven infiltration. Also, insulate the partition walls of such rooms and use weatherstripped doors and windows.

- Consider using an air infiltration barrier such as Tyvek (a registered trade mark of duPont Co.) to wrap the entire exterior of a house when using frame construction.
- Use stucco on the exterior of concrete block walls as an air barrier.
- If the house/room is to be air conditioned 24 hours a day, then it may not be a wise idea to naturally ventilate it periodically (e.g. after thunderstorms or at night). Although this practice saves energy, it might produce discomfort since such natural ventilation introduces excessive moisture into the room. Next day, when the air conditioner is run, the room humidity may stay unacceptably high.

### Choosing an Air Conditioner

Air conditioners are rated by a rating called EER (Energy Efficiency Ratio) or SEER (Seasonal Energy Efficiency Ratio). The higher the SEER rating, the lower the rated power consumption of the unit. However, the SEER rating does not tell you anything about its dehumidification ability. The dehumidification ability of an a/c unit is expressed by its sensible heat fraction (SHF). Lower SHF means higher dehumidification ability. Ask your a/c dealer about the SHF number. It should be 0.7 or, at most, 0.8. Higher SHF air conditioners will not dehumidify adequately. We have found that, in general, high SEER air conditioners (e.g., SEER greater than 10 or so) have poor (i.e. high) SHFs.

A simple way to control SHF is to buy an a/c with adjustable fan speed. Many window air conditioners have this feature. The low cool (i.e., low fan) setting is used for nighttime when dehumidification is more important. Caution is advised here, since in some cases low air flow over the coil can damage the equipment.

Another way to control humidity is to buy a properly sized air-conditioning unit. Energy-efficient houses can have an air-conditioning requirement of only one ton per 1000 square feet, rather than one ton per 500 or 600 square feet for a regular house. It is best to go through a cooling load calculation to select an a/c.

A separate dehumidifier should be used only as a last resort for humidity control. This is because these units introduce sensible heat into the house which eventually must be removed by the air conditioner.

## Heat Pump Water Heaters

A good way to get “free” cooling and dehumidification is to use a “heat pump” water heater. These dedicated heat pump water heaters are manufactured as a separate unit (schematically shown in Figure 30) or as an integral unit, integrated with a hot water heater.

**Figure 30**  
**Dedicated Heat Pump Hot Water Heater**

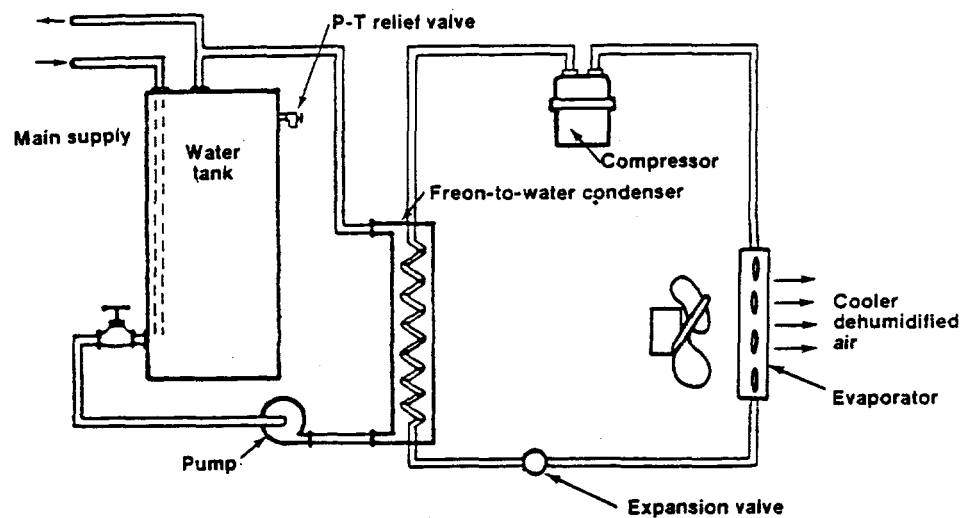

In a heat pump system, heat is picked up from the evaporator by cooling air and delivered to a condenser for heating domestic water. Heat pumps with a coefficient of performance above 2 are available; these can provide water heating at less than half the cost compared to a conventional electric water heater.

These heat pumps also provide cooling and dehumidification as a by-product. By locating the evaporator of the heat pump in the conditioned space, heat and moisture can be removed.



## CHAPTER 6

### BUILDING DESIGN

#### Thermal Energy Storage

Buildings located in Indonesia, Malaysia, the Philippines, Thailand, and other Pacific Rim countries can take significant advantage of thermal energy storage. The effect of the storage is to provide a "sink" into which heat on the inside of the building may be stored. We must also have some means of removing this heat and rejecting it outdoors on a cyclical basis or this strategy will not work.

During large parts of the year, charging of the storage can be accomplished through natural or forced building ventilation during the periods when the outside air conditions are comfortable. A building that has sufficient and properly distributed internal thermal mass will often be comfortable during an entire day if nighttime temperatures drop below 68 degrees F and the building is well vented. This is a common occurrence many days of the year.

Thermal energy storage may take a number of forms. The most common for building cooling applications is the concrete block wall. Concrete floors and ceiling panels are also applicable but floors are sometimes covered by carpets that act as insulators and severely limit the thermal coupling between the room air and the storage mass. This coupling is important to the usefulness of a heat storage system. Thus, concrete block buildings that are insulated at the interior face of the walls provide much less useful thermal energy storage for the building interior.

To be most effective, thermal storage mass is directly exposed to the room air. Using no finish on the interior of block walls, decorative stucco, tile, plaster, or masonry products can provide the necessary thermal coupling.

Another effective location for concrete block walls are the interior building partitions and party walls between multiple units. This maximizes the exposed surface area of the block, decreases its recharge time, and increases its useful storage capacity.

Both Swedish and American researchers have made interesting proposals concerning the use of the cores that are present in many concrete building products. In these cases, inside wall surfaces should be very well sealed to avoid air leakage and moisture problems. The cores of concrete blocks and manufactured concrete floor slabs can be used as air plenums and the thermal

storage mass may be cooled from both the inside and outside during discharge cycles. A few residences have been constructed in northern climates using this concept for solar heat storage, and the concept has been used in commercial buildings where large daily internal gains often dominate the building load. In this application evaporatively cooled ventilation air is passed through prefabricated floor/ceiling slabs at night, providing pre-cooling. This mass is then used as a sink for internal heat on the following business day.

## Air Infiltration

Air infiltration into buildings is a major cooling load in mechanically air-conditioned buildings in the Pacific Rim. At a design infiltration rate of 0.75 ach (air changes per hour), the infiltration in a typical residence represents 25 to 30% of the air-conditioning load. The more humid the climate, the more severe the infiltration load. Even though outside air temperatures are not excessively high in humid climates, the air's energy content is quite significant because of its high moisture content.

Air conditioners remove moisture from the room air by condensation on the evaporator coil. This condensation costs the cooling system roughly 1000 Btu per pound of moisture condensed. As a result, moisture removal constitutes 70 to 80% of the infiltration load. It is not uncommon for an air conditioner to remove up to 50 pounds of moisture from a 1500-square-foot home on a hot day.

If a building is closed and mechanically cooled, it is quite important to protect against air infiltration. For most new buildings, major air infiltration sources occur at several points in the building:

- At wall top plates where electrical and plumbing vent systems go into and out of attics. Also at attic access hatches.
- At the juncture between the wall sill plate and the floor slab.
- At utility penetrations.
- At cracks around windows and doors.
- At joints in block walls, and porous units.

Infiltration can easily occur at joints and edges of any penetration through the building envelope, but the three points above represent particularly common and major locations. Electrical and plumbing systems are also particularly problematic. Recessed ceiling electrical fixtures are notorious infiltration sources, but penetrations at wall top plates in buildings are often overlooked as major sources. They should all be sealed at system installation. Attics

represent particularly harsh environments, especially during the day when the air is usually both hotter and wetter than the outside air. Air communication between the house and attic should be avoided completely.

Infiltration is often increased by the air conditioning system itself. The attic has become a common location for air handlers and ductwork. Both may leak, but air handlers may draw attic air into poorly sealed returns and directly across the cooling coil. This type of infiltration places a direct and severe load on the air conditioner. Under these conditions, measured residential infiltration rates have been shown to double when the air conditioner is operating. Air handlers should not be located in attics.

Obviously, poorly weatherstripped windows and doors are to be avoided and jalousie windows are outlawed in air-conditioned buildings. But what about vapor retarders? This is a complex problem and some basic distinctions are made at the outset. The problem is divided into two functional areas: vapor retarders and air infiltration barriers. There is mounting evidence that moisture problems in building wall and roof systems are the result of either actual water leaks at the building skin or of uncontrolled air infiltration that carries moisture-laden air. Generally, vapor retarders are not required in hot, humid climates. Air infiltration barriers are highly advisable in all climates and should probably be used even when a vapor retarder has also been installed.

Air infiltration barriers appear to be more applicable than vapor retarders. A vapor permeable, exterior infiltration barrier is the option of choice in tropical buildings. All cracks and joints are thus protected at the building exterior with a continuous seal. This is very difficult to accomplish at the interior of the envelope because of partition walls and the numerous required wall penetrations.

If a continuous exterior air infiltration barrier is used, the major locations for infiltration are sealed, and high quality windows and doors are used, infiltration rates will be quite low in summer. For cooling load reduction, infiltration should be minimized, but some air exchange between inside and outside is required for health reasons. Building ventilation should be provided through controlled venting of kitchens and baths where internally generated heat, moisture and pollutants are most likely to occur. In the tropics, every room should have at least one window or operable vent.

### Shading and Daylighting

Both structural and window shading are critically important to good building design in the tropics. However, electric lights produce heat in the building. They also can be costly to operate and add to the air-conditioning load.

Daylighting can thus be very important. The concept of daylighting can seem contradictory until lighting systems are understood. Daylight is composed of both visible and invisible energy. Lighting from electrical lighting fixtures has similar characteristics. The efficiency of lighting systems is generally expressed in terms of its luminous efficacy. This is an efficiency term which relates the useful visible light in the spectrum to useless invisible energy which is transformed into heat. The higher the luminous efficacy the more efficient the lighting system becomes with respect to passive cooling.

Daylight — especially diffuse daylight — has a very high luminous efficacy as compared even to fluorescent lighting systems. It quickly becomes apparent that the relationship between shading and daylighting can be a major source of heat reduction in passive building design. The design problem becomes one of allowing indirect, diffuse daylight into the building space in such a way as to provide sufficient lighting and at the same time prohibiting direct solar radiation from entering the building.

## Shading

Window shading to prohibit direct solar radiation from entering glazed areas is a geometric problem which is controlled by the path of the sun through the sky. Due to the tilt of the earth on its axis, the problem is complicated to a certain extent and becomes time and latitude dependent. However, charts which delineate the apparent path of the sun through the sky are available for all latitudes and times of the year. These charts, in conjunction with graphical shading mask calculators, can be used to design fixed shading devices which eliminate direct solar gains to windows for all or parts of the year.

Fixed shading devices are not always appropriate and alternate means of reducing solar gain are often needed for east and west window orientations. Though exterior mounted shading represents a superior level of control and protection in the tropics, interior movable shades, curtains, window films and awnings can reduce solar gains through windows. Associated with each of these shading devices is a shading co-efficient (SC). Shading coefficients are calculated in such a way that when they are multiplied by the standard solar heat gain which can be expected through 1/8" double strength clear glass, a calculation of the expected heat gain is provided through glazing which is protected by the device. The lower the shading coefficient, the better the protection from solar radiation. Table 10 contains a listing of shading coefficients.

**Table 10**  
**Effective Shading Coefficients for Various Window Shading Devices**

**A. EXTERIOR SHADING DEVICES**

1. Awnings	
a. Slatted Venetian (2/3)	0.43
b. Slatted Venetian (Full)	0.15
c. Canvas (Full)	0.25
2. Horizontal Louvres	
a. Fixed	0.30
b. Moveable	0.12
3. Vertical Louvres	
a. Fixed	0.20
b. Moveable	0.12
4. Shading Screen	
a. Medium	0.28
b. Dense	0.23
5. Roll Shades	
a. Uninsulated	0.10
b. Insulated	0.05

**B. INTERIOR SHADING DEVICES**

1. Roller Shades	
a. Dark Color	0.81
b. Medium Color	0.62
c. Light Color	0.41
2. Venetian Blinds	
a. Dark Color	0.75
b. Medium Color	0.65
c. Light Color	0.56
d. Aluminum	0.41
e. Pella Slimshade	0.34
3. Window Films	
a. Reflective	0.35
b. Absorptive	0.75
	(continued)

4. Curtains	
a. Dark Color	0.58
b. Medium Color	0.47
c. Light Color	0.40

#### C. VEGETATIVE SHADING (EXTERIOR)

1. Light Shading Only	0.65
2. Dense Trees Providing Heavy Shade	0.30

### Glass

Sunlight is an important factor of well being. It warms our heart as well as our bones. In air-conditioned buildings, sunlight coming through building glass is also a major cooling load. It is necessary, therefore, to strike a very delicate balance between the daylighting requirements of a building and the shading requirements.

The most pleasant and efficient way of providing daylight to a building interior is from above. But avoid skylights unless you are a daylighting expert or have hired one, or are installing skylights with tint or mini-blinds, or operable controls. Vertical glass in the form of clerestory windows or roof monitors in cathedral and multi-story spaces are far safer. However, in general, use only 1 square foot of glass for each 100 square feet of floor space for daylighting from above.

Buildings require windows for purposes other than daylighting. Ventilation, views, aesthetics and egress are all very important window considerations. Windows and other building glazing must be protected from solar radiation during much of the year in most tropical locations.

As you would expect, the roof of a house receives the greatest amount of solar radiation (See Table 3). However, the east and west faces of the building also receive large amounts of solar radiation. The radiation on the east face peaks early in the morning when the sun is low in the eastern sky. Likewise, radiation on the west face peaks late in the afternoon when the sun is low in the western sky, and coincident with afternoon high temperatures. Because the sun is so low in the sky, the most effective method of protecting east and west windows is with vertical shading devices like awnings and shutters. It is clear, however, that these devices also may restrict both view and ventilation potential, and require occupant adjustment. Alternative shading techniques like reflective window films, although not as protective, are less restrictive of view and ventilation potential. Figure 31 represents a table

of effective shading coefficients for various window shading devices. The lower the shading coefficient, the more energy efficient.

**Figure 31**  
**Effectiveness and Electrical Savings of 8 Shading Strategies**

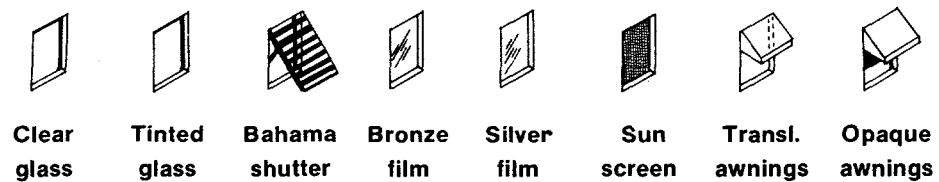

**Cooling season shading effectiveness (CSSE)**

**0      0.29      0.59      0.63      0.68      0.71      0.71      0.82**

**Cooling season electrical savings, kWh/ft<sup>2</sup>yr @ SEER = 6.8**

**0      2.97      6.11      6.44      6.96      7.25      7.33      8.42**

Window shading may also be accomplished with roof overhangs, especially since both north and south gains need to be controlled in the tropics. Again, refer to Table 3 on solar radiation data for an example of incident radiation on building surfaces.

## Visual Comfort

When daylighting is used to provide illumination in buildings, an understanding of visual comfort on the part of the building designer is required. Since the eye will adjust itself to variations in lighting levels which are in the field of view, large differences within a space must be avoided or visibility will be impaired, even at high illumination levels. It is more important that lighting level be evenly distributed throughout the field of view than lights be at high illumination level. For this reason indirect light, which is either bounced off of ceilings or is brought into the building high in the space, is more effective than bright one-sided window lighting.

A second problem which is often associated with daylighting is glare. The presence of direct beam light sources can destroy visibility. Windows which are at eye or task level should be carefully designed in a way which filters and redirects daylight and exterior bright spots to avoid this problem. Exterior vegetation which provides a soft background and/or louvers which redirect lighting to ceilings are often used for this purpose.

Exterior sky characteristics are of major importance to daylighting design. These conditions fall into three major categories: clear skies, partly cloudy skies and overcast skies.

The characteristics of each are:

1. Clear Skies — 0 to 30% of skydome classified as cloudy.
  - characterized by intense bright sunlight and relatively dark (blue) skies — few clouds.
  - illumination levels range from 5,000 to 12,000 footcandles.
2. Partly Cloudy Skies — 40% to 70% of skydome cloudy.
  - characterized by intense direct sunlight and diffuse light bounced from clouds. Usually with excessively bright clouds
  - illumination levels vary widely - when sun penetrates directly to building site, will provide highest level of illumination available and the brightest visual impact (white clouds) from within building.
3. Overcast Skies - 90% to 100% of skydome is cloud covered.
  - characterized by uniformly intense light quality - may be dark or bright with relatively low variation in brightness.

- illumination levels vary from few hundred to few thousand footcandles

These sky conditions can be used along with local climate and sky condition data to make an approximate estimate of the extent to which daylighting will reduce electrical lighting demand.

Knowing the monthly average sky conditions allows the use of illumination charts to calculate annual average daylighting contribution for building interiors. Experts suggest that builders of large homes use a daylighting computer program to verify performance estimates.



## CHAPTER 7

### HOT WATER FOR HOT CLIMATES

#### Introduction

Water heating accounts for approximately 25% of the total energy consumption of a typical single-family residence. This amount is almost as large as the portion for air conditioning (30%), reflecting the fact that water heating is a year-round requirement in the home in these climates.

For commercial mercantile buildings such as stores, offices, and banks, air conditioning and space heating dominate the use of energy, accounting for approximately 45 and 15% respectively. Water heating consumes only about 12% of the total energy used in these buildings because of the relatively small demands for hot water. However, in hotels, restaurants, and hospitals, where there is a large requirement for hot water, the water-heating fraction of total-energy use may be as high as the one-fourth consumed by residences.

Since water heating does require such a significant amount of energy, the design of a hot water system for an energy-efficient building is of major importance.

#### Hot Water Principles

A domestic hot water (DHW) system should be designed to provide sufficient hot water at the desired temperature to all users, at all times of use, and at all locations. By breaking down this criteria into its component parts, we can list the basic questions that must be addressed in designing a DHW system for any building:

1. Who will be using the hot water?
2. What temperature should the water be delivered at?  
(What will the hot water be used for?)
3. Where will the hot water be used?
4. When will the water be demanded?
5. How much hot water is required?

#### Uses

Hot water uses can be divided into three large areas:

1. Residential — This includes the domestic uses of bathing, cooking, dishwashing, clotheswashing, and personal hygiene in a typical family unit.
2. Commercial — This includes the same uses as residential, but in larger quantities as would be expected in a commercial or institutional setting such as hotel or hospital.
3. Industrial — The uses here are more specialized (sterilizing, mixing, heating, etc.) and, therefore, will not be covered in this book.

The user in each of these areas may be either a person or a machine that requires a particular quantity and quality of hot water for a specific use. This person or mechanical process must be satisfied with both the volume and temperature of the hot water at the point of use. It is the object of the system design to achieve this satisfaction for all users of the DHW system.

## Temperatures

Hot water provides a variety of uses. However, it will not be satisfactory to the user if it is not at the proper temperature. Table 11 lists the normal temperature requirements that will satisfy the majority of users for various hot water applications. Slightly lower temperatures may be satisfactory in some instances.

**Table 11**  
**Representative Hot Water Use Temperatures**

Use	Temperature	
	F	(°C)
Lavatory		
Hand washing	105	(40.6)
Shaving	115	(46.1)
Showers and tubs	110	(43.3)
Therapeutic baths	110	(43.3)
Commercial and institutional laundry		
Wash	140	(60.0)
Sanitizing rinse	180	(82.2)
Commercial and institutional laundry	180	(82.2)
Residential dishwashing and laundry	131	(55.0)
Surgical scrubbing	110	(43.3)

It is obvious that different temperatures of hot water may be required by the same user — residential, commercial, or industrial — because of different end uses. Generally, when water comes into contact with the human body, it should not be above 105–115 degrees F.

Sanitation regulations make 180 degree F water mandatory in the rinsing cycle for dishwashing in public places. However, if chemical sanitizing rinses are used, the temperature requirement may be lower. Knowledge of the specific temperature needs of the hot water application is essential in designing a water heating system.

## Requirements

The typical hot water requirements for domestic use are listed in Table 12. These figures are averages obtained from manufacturers' literature and various studies on household behavior. As evident in the table, there was a significant change in hot water consumption for U.S.-manufactured clothes-washing machines since 1979. Most manufacturers changed their proportion of cold to hot water for the "warm" setting from a 50/50 mix to a 60/40 combination in order to conserve hot water. Dishwasher manufacturers also decreased the amount of hot water required by their machines at the same time.

**Table 12**  
**Domestic Hot Water Consumption**

USE	HOT WATER USE (GALLONS)		
	COMPACT	FULL LOADS STANDARD	LARGE
<b>I. CLOTHESWASHING MACHINE</b>			
<b>1. 1979 AND LATER MODELS</b>			
a. hot wash/hot rinse	22 gal.	30 gal.	38 gal.
b. hot wash/warm rinse	17	23	29
c. hot wash/cold rinse	12	16	20
d. warm wash/warm rinse	11	15	19
e. warm wash/cold rinse	6	8	10
f. cold wash/cold rinse	0	0	0

(continued)

## 2. PRE-1979 MODELS

a. hot wash/hot rinse	27 gal.	38 gal.	48 gal.
b. hot wash/warm rinse	22	30	39
c. hot wash/cold rinse	15	20	25
d. warm wash/warm rinse	16	22	29
e. warm wash/cold rinse	9	12	15
f. cold wash/cold rinse	0	0	0

## II. DISHWASHING

1. DISHWASHER MACHINE	SMALL	LARGE
A. Pre - 1979 Models	10 gal.	14 gal.
B. 1979 and Post -1979 Models	9	10
2. Hand Dishwashing	6 gal. (4 - 8 gal. range)	

## III. PERSONAL HYGIENE

1. SHOWERING	
A. Regular Shower Head	12 (1-3 gal. of hot water per min.)
B. Flow-Restricting Shower Head	6 (0.5-1.5 gal. of hot water per min.)
2. TUB BATHING	20 (10-30 gallon range)
3. OTHER (HAND WASHING)	4 (2-6 gallon range)
IV. FOOD PREPARATION	3 (2-4 gallon range)

## Demand Periods

The actual time-of-day that hot water is used is an important consideration in DHW system design. A system must be able to meet the peak hot water demand imposed on it daily. For residential and many commercial purposes, peak demand generally runs in a short period when people are bathing or showering. Normally, only a percentage of the available water faucets are turned on at any one time. However, in the case of a school gymnasium, for example, there is a good chance all the faucets will be demanding hot water at once. The designer must be aware of any time-based requirements like this to ensure that sufficient hot water is available. Figure 32 illustrates the average daily hot water use profiles (hourly peak demands based on 15-minute interval data) for a typical family of four. The difference in the profiles demonstrates the increased demand and change in time of use of hot

water for the colder months. This points out the need to use the “worst-case” design conditions when determining peak hot water demand. Average hot water use profiles should also be used with caution because week-day water use generally differs from week-end use. Furthermore, average profiles may not reveal the peak demand that occurred in the sample interval.

**Figure 32**  
**Average Hot Water Use Profile for a Typical Family of Four**

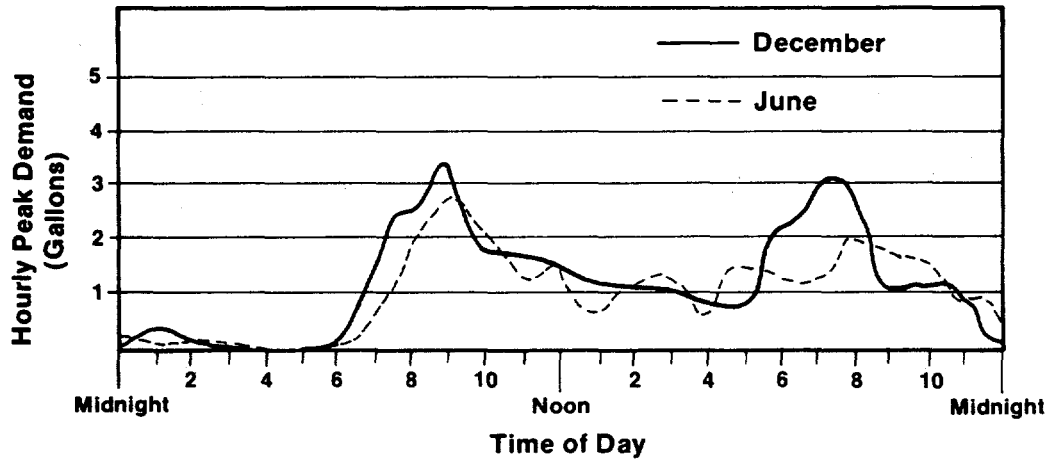

Since water takes time to heat up, a water heater must either have very high input energy or sufficient storage capacity to meet the period of peak demand. Generally, good system design combines some storage with lower input energy to provide for the peak demand. “Recovery” of the water heater’s storage can then take place over a relatively longer period of time under reduced load.

Recovery capacity is defined as the number of gallons that can be heated in an hour (gph) at a particular temperature difference. It is extremely important when comparing water heaters to ensure that their recovery ratings (gph) were made at the same temperature difference. Furthermore, where cold water temperatures average 70 to 80 degrees F, it is also important to use a realistic temperature difference when sizing is based on recovery.

## Distribution

Proper design of the hot water supply piping is essential for a DHW system to satisfy the user. For a storage water heater, the point of use of the hot water is generally remote from the storage tank. The piping, therefore, needs to be able to provide the required hot water at the remote location, particularly

during the period of peak demand. Pipes not only have to be sized properly but also insulated to reduce heat loss and wasted "warm-up" water.

The principles of pipe sizing are the same for hot water as for cold water. The Hunter Method is generally used in both residential and commercial buildings to determine the required flow rates in the supply piping. This method uses the concept of "fixture units" to account for the diversity of use that can be expected from a number of use points.

### System Types

In the nonfreezing Pacific Rim countries, the direct ("batch-type") solar water heater where water flows through the collector is the system of choice. Direct solar water heaters can be classified into three different types: Integral Storage or Breadbox, Thermosiphon, and Pumped.

Figure 33 shows a breadbox type solar water heater. These are the simplest types of solar water heaters, though their performance is also poorer than the other types. These are basically solar collectors with internal storage tanks, which use their surfaces as the absorber.

**Figure 33**  
**Integral Collector (Breadbox) Storage Solar System**

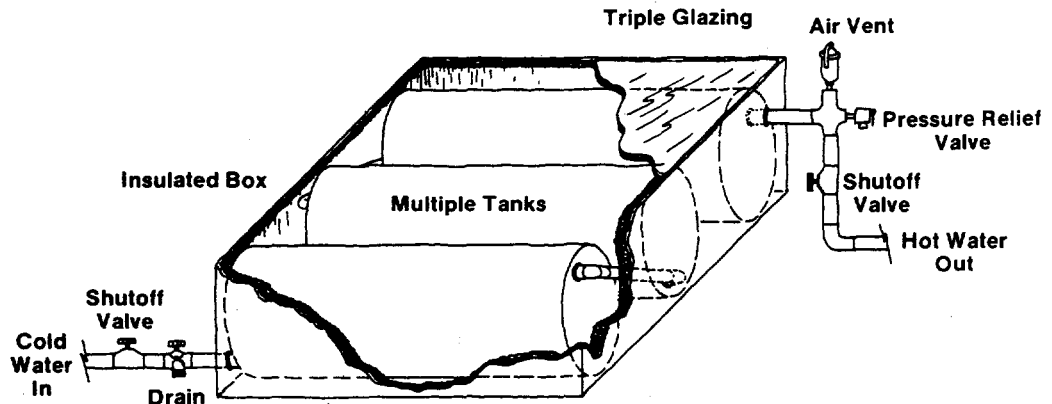

Figure 34 shows a horizontal thermosiphon system. By physically separating the collector from the storage tank, the efficiency is increased. The thermosiphon water heater works naturally, with hot water rising into the tank which must be located above the collector. Figure 35 is a detailed diagram of a vertical thermosiphon water heater. Note that there are some limitations to

the use of thermosiphon systems because of possible constraints in properly locating the collector above the tank.

Figure 36 shows the details of a pumped solar water heater. Since the pump provides circulation, it is no longer necessary to locate the storage tank above the collector. However, system complexity is increased. One now needs to provide a check valve so that the tank does not lose hot water at night by thermosiphoning to the collector, as well as some means of turning the pump on and off. A popular option used by many builders is a small photovoltaic panel to provide power for the pump.

**Figure 34**  
**Thermosiphon Solar System - Horizontal Tank**

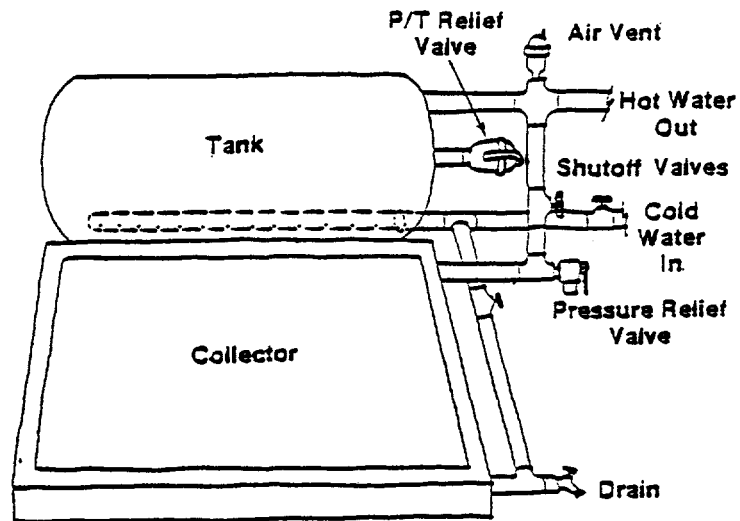
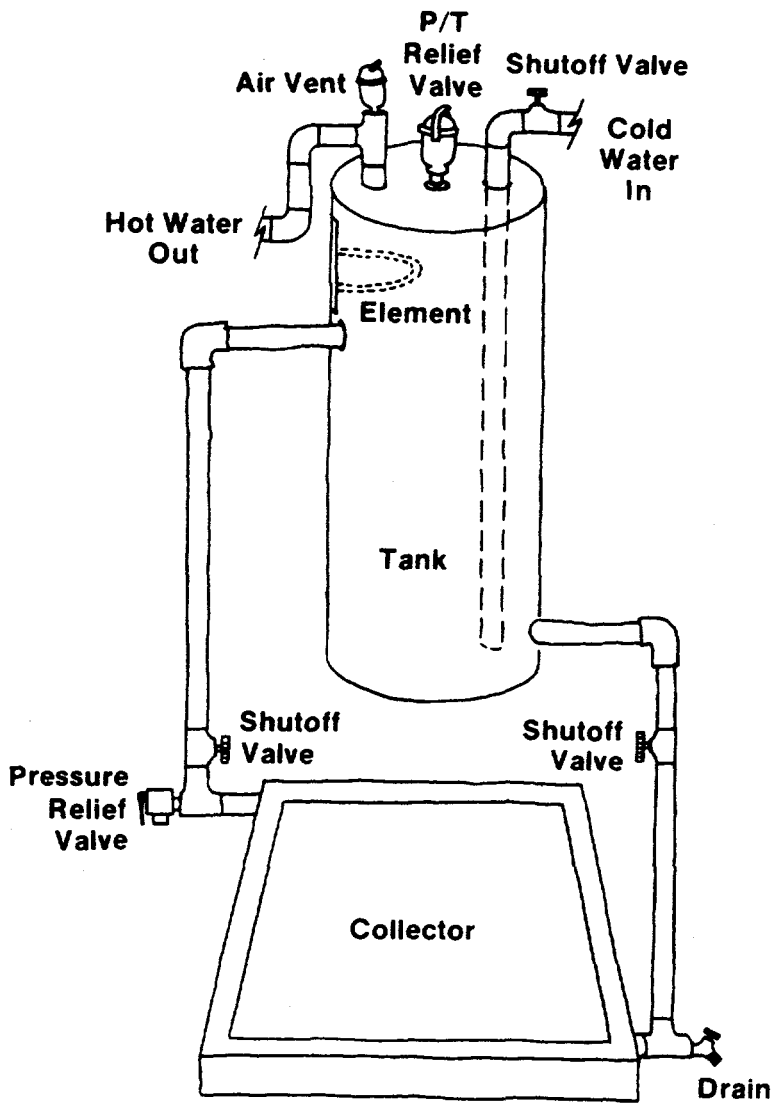
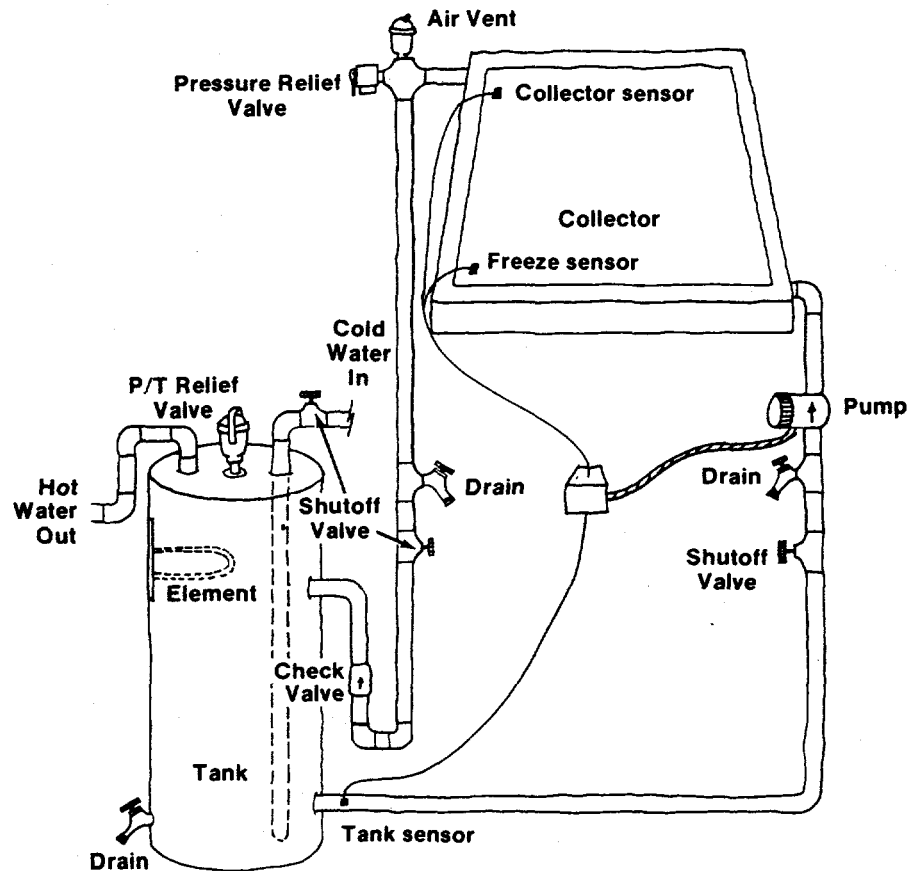

Figure 35  
Thermosiphon Solar System - Vertical Tank



**Figure 36**  
**Pumped Direct Solar System**



### System Sizing and Orientation

The most important and difficult thing to estimate is the hot water demand in gallons per day (GPD). It is recommended that you work with a qualified solar installer or distributor. While many plumbers, electricians and other tradespeople are knowledgeable about aspects of solar systems, experience has shown that a specialist in solar energy can offer many useful ideas and assistance. Proper sizing of a system will ensure optimum performance and maximum energy savings. A system should be designed and sized for the occupants and their needs.

You can obtain useful information on the performance of many available solar systems by contacting the Florida Solar Energy Center for a copy of their free booklet, *Intermediate Temperature Thermal Performance Ratings*. Write to the Public Information Office, FSEC, 300 State Road 401, Cape Canaveral, FL 32920-4099, U.S.A. You can use this material for general in-

formation as well as to work with your solar installer to choose the best system for your needs.

### Storage Tank

- 1.5 - 2.5 gal/sq. ft. of collector; optimum about 2.0.

### Materials

- Piping at least 3/4" I.D. for solar system piping or collector absorber tubing.
- Solar piping need not have pipe insulation if it is covered by a sheet metal jacket painted black.
- Solar tanks can be made of galvanized steel, concrete or plastics which can stand up to 180 degrees F. They also need not be insulated if placed in a sunlit area with a sheet metal jacket painted black.
- Collectors should have:
  - Absorber - aluminum or galvanized sheeting wrapped around tubing.
  - Insulation - Polystyrene (Styrofoam)
  - Glazing - Glass, preferably low iron. A cut piece viewed on edge appears bluish or white rather than green.

For a further description of both active and passive solar water heating systems, and a list of manufacturers, distributors and designers, contact SEIA for a copy of *Solar Thermal: A Directory of the U.S. Solar Industry*.

## CHAPTER 8

### PHOTOVOLTAICS

#### Photovoltaic Effect

Photovoltaic cells are devices which convert light into electricity. Because the source of light (or radiation) is usually the sun, they are often referred to as solar cells. The word photovoltaic comes from "photo," meaning light, and "voltaic," for voltage. The output of a photovoltaic cell (or a connected array of cells) is direct current electricity.

#### Peak Sun Hours

The amount of terrestrial power received on a properly tilted surface on a clear day is approximately  $1 \text{ kw/m}^2$ , which is referred to as peak (or full) sun condition. Note that it is considerably less than the solar constant ( $1.353 \text{ kw/m}^2$ ). This is indicative of the attenuating nature of the atmosphere. If we have  $1 \text{ kwh/m}^2$  of sunlight for one hour, we receive one (peak) sun hour of energy.

#### Cell Materials

A variety of semiconductor materials are used in fabricating photovoltaic cells and modules. These include single crystal silicon, polycrystalline silicon, amorphous silicon and a large number of advanced technology materials — most notably cadmium sulfide and gallium arsenide.

#### Modules and Arrays

A typical solar cell produces approximately 0.5 volts and a current that depends strongly on the intensity of the sunlight and the area of the cell. In order to get more usable values of voltage and current, solar cells are connected in series to increase voltage, and the series of cells are connected in parallel to increase current output. Twenty to 60 or more cells are packaged together with a transparent cover (usually glass) and a watertight seal to form a module. In turn, these modules are wired together in a series - parallel combination to form an array that best meets the needs of the application.

Note that the words "module" and "panel" should not be used interchangeably. A panel is a group of modules which have been mechanically and electrically connected to form building block subassemblies for the array.

### Current-voltage Characteristics

The most important performance descriptor for a photovoltaic cell, module, or array is its current-voltage (or I-V) characteristic (Figure 37). For given irradiance, the operating voltage and current vary with load. Current will vary from zero (corresponding to infinite load or open circuit) to a maximum called  $I_{SC}$  (corresponding to zero load or short circuit). The maximum operating voltage,  $V_{OC}$ , corresponds to open circuit (oc) conditions and the voltage is zero at the short circuit condition. Thus,  $I_{SC}$  and  $V_{OC}$  are two limiting parameters that are used to characterize a photovoltaic cell (or module or array) for given irradiance and operating temperature.

**Figure 37**  
**Current-Voltage (I-V) Characteristic for a Solar Cell**

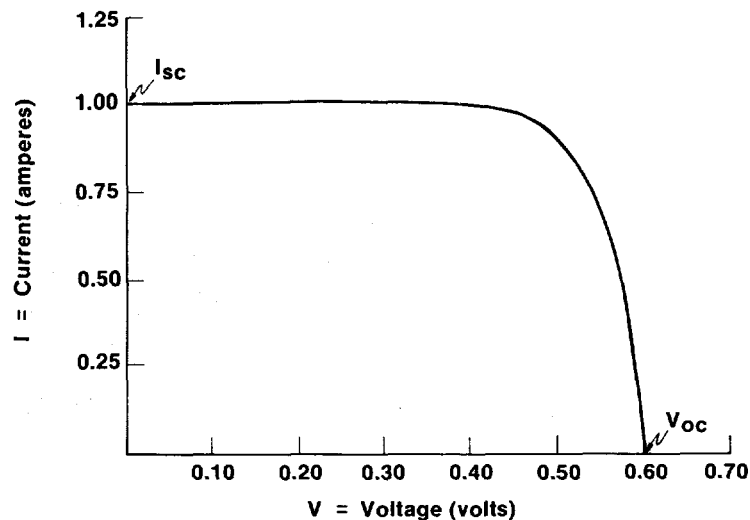

The maximum power point is the desired operating point for a PV cell (or module or array) and corresponds to the current and voltage on the I-V curve which produces maximum power.

The fill factor is an operating characteristic which indicates the performance quality of the cell. It is the ratio of the maximum power and the product of  $I_{sc}$  and  $V_{oc}$ .

The operating temperatures of solar cells are important in that high operating temperatures have a negative effect on both power output and long-term durability.

Commercially available silicon cells have efficiencies as high as 15 percent. Laboratory efficiencies of about 20 percent have been achieved. Considerable research is in progress to improve efficiency, verify performance, lower production costs and increase reliability and durability.

## Array Types

There are two basic types of arrays: flat-plate and concentrating.

Flat-plate arrays utilize both diffuse and direct sunlight and can operate in either a fixed orientation or in a sun-tracking mode. For most applications, flat-plate arrays are fixed in orientation, with the notable exception being central power station production of electricity in the southwest U.S.

Photovoltaic concentrators use only direct (beam) radiation and require sun tracking. Because of the high temperatures resulting from concentration, they are cooled — either passively or actively.

Photovoltaic concentrator technology can be broadly divided into two classes: baseline PV concentrators and advanced PV concentrators. Baseline concentrators use planar-junction silicon cells and either linear (25 to 75x concentration ratios) or point-focus (50 to 250x concentration ratios) Fresnel lenses. Maximum annual efficiencies are above 15 percent.

Advanced concentrators use more exotic cell materials such as aluminum gallium arsenide or non-planar silicon cells or multiple junction devices. Concentration ratios are from 500 to 1000x. They use point-focus Fresnel lenses, domed or curved facet, often with secondary focusing. Annual conversion efficiencies of greater than 20 percent have been achieved.

For further information and examples of photovoltaic uses and applications, contact SEIA for a copy of *Solar Electricity: A Directory of the U.S. Solar Photovoltaic Industry*. This publication gives detailed information on U.S. manufacturers and system suppliers, photovoltaic sales companies, and balance-of system manufacturers, along with other helpful reference information.

## CHAPTER 9

### RECOMMENDATIONS FOR BUILDING A HOME IN THE PACIFIC RIM

#### Site

- If possible, select a site which can accommodate a house that is longer in the east/west direction than in the north/south.
- The more trees the site has, the better — especially if they are to the east and west of the proposed building location.
- Don't let vegetation impede the natural air flow.
- Determine if there are sufficient breezes at the building location.
- Landscape with natural ground covers which require little maintenance and use little water.
- *Minimize the use of asphalt and concrete paving materials.*

#### Building Layout

- Plan basic building shape and orientation, windows, and room placement at the same time. Emphasize good cross ventilation and admission of natural light.
- Locate the major living/eating/sleeping areas according to the time of day they are normally used. Nighttime and early morning activity rooms should be on the east side and midday activity rooms towards the west side of the building.
- Use the east and west ends of the building as buffer zones: place closets, stairs, utility rooms, bathrooms, garages and screen porches at these locations.
- Provide a means by which unused areas can be closed off from the rest of the house. This should be done in conjunction with "zoned" mechanical cooling systems.

#### Windows and Skylights

- Use tight-sealing awning windows as the preferred window type. Awning windows protect against rain and provide a larger opening for a given window area. Use skylights and sliding glass doors that seal tightly when shut as well.

- Use insulated glass for large glazed areas.
- If good, permanent vegetative shading is available on east or west, or if sizeable overhangs (perhaps screened-in porches) are used, then east or west facing windows can be used.
- If a room has only one window (or sliding glass door), use an over-door transom to improve ventilation..
- Use wingwalls to augment ventilation through rooms having windows on only one outside wall.
- Larger numbers of smaller skylights and windows provide better spatial uniformity of illumination, but fewer number of larger apertures provide stronger contrasts in the space.
- For interior spaces that are dark enough to require additional lighting for performance of visual tasks for more than a few hours a day, use controllable skylights, clerestories, and roof monitors to provide some of this light for single-story (and the top floor of multi-story) buildings.
- For skylights with shallow wells (less than or equal to the smallest dimension of the skylight) that are not heavily tinted and are clear and transparent, a sizing rule of thumb is to have the total skylight area be up to six percent of the area to be illuminated. For heavily tinted or permanently shaded skylights or those with deep wells, this area should be increased accordingly.
- When skylights are equipped with operable shades or shutters that will be used regularly, total skylight area can be enlarged to 10% to 15% of the illuminated area to provide better early morning, late afternoon, and overcast day performance, without excessive mid-summer midday radiant heat gain.
- Consider using operable skylights that can be opened to improve ventilation in the home.

## Doors

- Use insulated core exterior doors with magnetic weatherstripping. If practical, provide an airlock entry for the most used exterior door.

## Floor Insulation

- For slab on grade construction, perimeter insulation is desirable but may not be cost-effective.
- For wood floors above the ground, insulate with at least R-13 batt insulation.

## Wall Insulation

- For designs which use thermal mass, concrete block construction is a practical method. The interior surface of the block should be either painted, plastered, or have drywall glued to it. The exterior surface of the block should be insulated with 3/4" foil faced isocyanurate type insulation, then nail 1" x 3" furring strips at 16" o.c. (either vertical or horizontal) to create a radiant barrier airspace. Any exterior finish can be applied to these furring strips. Another good idea is to use pre-insulated block with good exterior shading and light-color stucco.
- For designs which are not concerned with thermal mass, either concrete block or frame construction can be used. Each one is insulated differently as described below:
- Concrete block - The exterior surface of the block can be covered with any finish as desired. The interior surface of the block is insulated with 3/4" foil faced isocyanurate insulation, then 1" x 3" furring strips are nailed to create a radiant barrier airspace. The drywall is nailed to these strips and finished as desired.
- Frame - A 2" x 4" stud wall at 16" o.c. is the standard method of frame construction. This wall should be insulated with 3-1/2" of fiberglass batt insulation and drywall used as the interior finish. An 1/8" foil-faced, cardboard structural sheathing should be nailed to the outside surface of the studs. Then 1" x 3" furring strips are nailed to the studs (through the sheathing) at 16" o.c. to create a "dead" airspace. Any exterior finish can be applied to these furring strips.

## Roof Insulation

- Attic spaces: place R-19 batt or blown insulation in the ceiling and 1 layer of perforated builders foil (or equivalent) in the roof plane (either stapled to the bottom of the top chord of the truss or to the backside of the plywood sheathing). In either case the foil side should face down to minimize dust collection on the foil surface.

- Cathedral ceilings: Use the same principles as for attic spaces, insuring that there is a minimum of 3/4" airspace against the foil.
- Ventilate attic spaces with continuous ridge and soffit vents. Make sure insulation does not block air inlet into the attic. Do not use powered roof vents for attic ventilation as they are not usually cost effective. Turbine vents are acceptable but may need periodic replacements, cause noise, and could leak in heavy rain.

## Infiltration

- In frame construction, seal the joint between the plate and the concrete slab.
- Seal all cracks and joints around windows, doors and electrical outlets.
- In kitchen, bathroom, and laundry areas, provide a way to exhaust heat to the outside.
- Seal the attic access hatch, crawl space cracks and crevices, and other penetrations.

## Shading

- All fenestrations should have user-controlled options.
- Use overhangs to completely shade the south wall and windows during the summer. Overhangs can also help shade north, east and west windows and walls from the midday sun.
- Shading of north-facing windows is also needed to meet aesthetic requirements, to provide rain protection, and to block early morning and late afternoon summer sun.
- If east- or west-facing exposures are unavoidable, reduce glare and localized overheating with the following options:
  - Exterior vegetative shades
  - Exterior fixed louvered shades
  - Exterior operable shades
  - Interior operable shades (with reflective backing). Operable shades can be withdrawn when sun is on other side of the building.
  - Permanent window films or heavily tinted glazing for this purpose, though they can cause the window glass to heat up.

- Whenever horizontal or nearly horizontal glazings are used
  - provide fixed exterior shades, or
  - provide operable interior shades or shutters for control of mid-day mid-summer solar beam radiation.
- Whenever direct beam radiation is allowed to enter glazed areas or to illuminate bright surfaces just outside fenestrations, take measures to reduce glare.
- If outside reflectances are high, or if shiny surfaces such as automobile glass or chrome are in view of a window, use glare control strategies such as removal of the glare-producing object, blocking it with vegetation, or exterior shades and shutters that block glare but admit diffuse daylight.
- If exterior ground and scene reflectances are low, use larger window apertures, avoid tinted glazing, and use brightly (but diffusely) reflecting surfaces on exterior shades, but only if this can be done without producing excessive glare.

#### Finishes

- Use light-colored finishes on both the exterior and interior of the building.
- Avoid materials that give off toxic vapors.

#### Ceiling Fans

- Use of ceiling fans for enhanced comfort allows raising of thermostat setting. Each degree increase in thermostat setting may save about 8 percent of air conditioning energy.
- Select silent high-quality models.
- Install ceiling fans in as many rooms as possible (at least in the main living area and bedrooms). Select fan size from following chart:

<u>Big dimension of room</u>	<u>Min. fan diameter (in)</u>
12 ft or less	36
12-16 ft	48
16-17.5 ft.	52
17.5-18.5 ft	56
18.5 ft or more	2 fans

- If ceiling fans are not practical, use portable oscillating fans. Avoid power-consuming box type fans.

## Mechanical Systems

- Accurately calculate design loads. Don't guess!
- Follow the recommendations in this book and you should be able to use smaller-size units per square-footage of floor area.
- Select air conditioning equipment and prepare layout during preliminary design of the building.
- Do not oversize an air conditioning unit. Since the air conditioning unit runs at part load for most of the time, it is best to size the unit between 95 and 110 percent of the peak load.
- Sensible and latent heat capacities of the air conditioners should be considered when selecting a unit. The sensible heat ratio of the selected unit should be nearly equal to the sensible heat ratio of the building cooling and dehumidifying load.
- Two-speed air conditioners are well suited for moisture removal.
- While selecting split-system air conditioning units, do not select an oversized fan coil unit for a condensing unit. This raises the evaporator temperature and reduces latent heat removal capacity.
- Reduce the fan speed of an air conditioner to get more latent heat removal capacity. This also reduces the total capacity of the air conditioner and it operates for longer hours. The EER of the air conditioner is also affected slightly.
- Provide good ventilation in areas of moisture production like bathrooms and kitchens. It is wise to ventilate directly to outside. If air has to be vented to the attic, provide good ventilation of the attic.
- Use of a tight vapor retarder is not recommended in warm and humid climates.
- Never place vapor retarders on both sides of a wall.
- If ducts can be installed within the conditioned space (e.g., between the ceiling and drop ceiling space when ceiling height may permit it), air conditioning energy requirement may be reduced by as much as 15 - 25%.
- A properly designed ducting and air distribution system will provide better comfort. Avoid return air openings from floor grilles

which can collect dust particles. Provide easy access to filter for cleaning or replacement.

- Do not put ducts in crawl spaces, or put uninsulated ducts in attics.
- Use air conditioner fan on 'auto' mode for effective humidity control. If the fan runs continuously after the compressor turns off, the condensed water from the pan and cooling coil will re-evaporate into the room. Humidity control will be difficult.
- Use of an automatic thermostat with night setback and off/on control during unoccupied/occupied periods can save energy.
- Builders should insist on system performance specifications from dealer. According to Air Conditioner Contractor Association's Manual C, a contractor should provide a statement of system performance. This tells the buyer the degree of temperature control and uniformity he can expect the system to provide, and that these will be provided in each habitable room.
- Locate the thermostat on a centrally located inner partition wall, not on a garage wall or near a window.
- Do not dump condensate water near the house.

### Domestic Hot Water

- Use a solar domestic hot water system. The backup element should be turned off as much as possible, possibly with a timer set to match occupant needs.
- Centralize location of hot water tank in relation to bathrooms, kitchen and laundry room.
- Insulate distribution hot water lines that are not cast in slab.
- Allow sufficient space for storage tank to accommodate one day's hot water demand.
- Install storage tank with high insulation value on top of 1" insulation board.
- Stub out solar, waste heat recovery, or heat pump supply lines from bottom of tank and return lines to a level below element.
- Install appropriately-sized photovoltaic-pumped solar system. If roof location/solar access is not available, choose between waste heat recovery and heat pump water heater based on cooling requirements of the house.

- Consider using tankless water heaters where the standby loss does not heat the interior.

### Occupant Guidelines

- Avoid furnishings with affinity for moisture vapor. Avoid particle board construction.
- Use ceiling fans prior to activating the air-conditioning system.
- Avoid unnecessary daytime electric light, appliance or entertainment use.
- Do not night vent on especially humid occasions.
- Do not dry clothing or bedding indoors.
- Avoid sprays and insecticides.
- Vent bathrooms and kitchens when used.
- Use a microwave rather than oven or broiler for cooking.
- Dress appropriately for conditions.
- Close off unused rooms.
- Keep houseplants.

## CHAPTER 10

### APPENDIX

#### Glossary

The following glossary is taken from the *Passive Solar Design Handbook* (volume 3, *Passive Solar Design Analysis*), edited by Robert W. Jones (U.S. Department of Energy, July 1982).

A number of the terms relating to low-energy building design are included in this listing. However, you are cautioned that the list obviously does not include all terms involved in tropical building design, so you should be aware of other sources of definitions as well. For additional definitions and explanations of terms commonly used in tropical building which might not be in the following glossary, consult:

*Solar Dictionary*, by Carl Breuning and Fred Evangel (San Juan Pueblo, NM; The Energy Store, 1983); *Solar Energy Dictionary*, by V. Daniel Hunt (New York; Industrial Press, 1982); *Renewable Energy: A Glossary* (Oak Ridge, TN: U.S. Department of Energy, 1985), or "Glossary of Terms Used in Solar Energy," *Solar Energy*, vol. 33, no. 1, p. 97-114, 1984.

**absorption factor:** the fraction of solar radiation transmitted through a glazing system that is absorbed inside the building.

**adobe:** sun-dried block made of mud and straw, a traditional southwestern building material.

**air changes:** a measure of the air exchange in a building due to infiltration. One air change is an exchange of a volume of air equal to the interior volume of a building.

**attached sunspace:** solar collector that doubles as useful building space, also attached greenhouse, solarium. The term "attached" also more specifically implies a space that shares one common wall with the associated building. Compare with semi-enclosed sunspace.

**auxiliary heat:** conventional heat delivered to the building to supplement solar heat.

**base temperature:** a fixed temperature in the definition of degree days, usually 65 degrees F.

**Btu:** British thermal unit, 1054 Joules.

**clerestory window:** a window above and behind (north of) the principal south windows to illuminate north building zones.

**conductance:** a measure of the ease of heat transfer between two points, namely, the heat flow rate per degree of temperature difference per unit of area (Btu/h F square foot).

**conduction:** the transfer of heat through a static medium, usually a solid such a concrete.

**convection:** heat transfer between a surface and adjacent fluid (usually air or water) and by the flow of fluid from one place to another.

**declination:** the angular position of the sun at solar noon with respect to the plane of the equator. The declination varies between -23.45 degrees at the winter solstice and +23.45 degrees at the summer solstice.

**density :** the mass of a unit of volume of material (lb/cubic foot).

**diffuse radiation:** the component of solar radiation that has been scattered by atmospheric molecules and particles. The diffuse radiation is assumed to be isotropic; that is, equally intense from all points of the sky. Also solar radiation scattered by transmission through diffusing glazings.

**diffuse transmission:** the type of solar radiation transmission through a diffusing or translucent glazing. Namely, transmission that is scattered by interaction with the glazing material. The diffuse transmitted radiation is assumed to be isotropic; that is, equally intense in all directions.

**diffusing glazing:** a translucent glazing, or a glazing that produces diffuse transmission.

**direct gain:** the transmission of sunlight directly into the space to be heated where it is converted to heat by absorption on the interior surfaces.

**extinction coefficient:** a property of glazing material that characterizes the solar absorption in the material; namely, the fraction of radiation that is absorbed per unit of path length in the material.

**forced convection:** heat transfer between a surface and an adjacent fluid (air in the present context) stream that is produced by external means such as wind or a fan.

**glazing:** transparent or translucent material (glass or various plastics) used to cover the solar aperture.

**gypsum board:** a common material used to finish interior walls and ceilings to give the appearance of plaster. Also called plaster board, sheet rock, and dry wall.

**heat capacity:** a measure of the ability of an element of thermal storage mass to store heat; namely, the heat stored in an element of thermal storage mass per degree of temperature rise (Btu/F).

**heat load:** the heat loss from a building in a designated time period (Btu).

**hybrid system:** a solar system that combines some passive and some active elements.

**index of refraction:** a property of glazing material that determines the reflection characteristics of the glazing.

**indirect gain:** the indirect transfer of solar heat into the space to be heated from a collector that is coupled to the space by an uninsulated, conductive or convective medium (such as a thermal storage wall or roof pond).

**infiltration:** heat loss due to air exchange between heated spaces and the outdoors.

**infrared emittance:** a measure of the ability of a surface to emit infrared radiation; namely, the ratio of the infrared radiation emitted at a given temperature to the radiation emitted at the temperature by a perfect emitter.

**infrared radiation:** the type of thermal radiation whose wave length is above the wave length range of visible light. This is the preponderant form of radiation emitted by bodies with moderate temperatures such as the elements of a passive solar building.

**internal heat:** heat generated inside the building by sources other than the solar system or the space heating equipment such as appliances, lights, and people.

**internal sources:** the sources of internal heat other than the space heating equipment such as appliances, lights, and people.

**isolated gain:** the transfer of heat into the space to be heated from a collector that is thermally isolated from the space to be heated by physical separation or insulation (such as a convective loop collector or an attached sunspace with an insulated common wall).

**lightweight absorption fraction:** the fraction of solar radiation that directly heats the air when it is transmitted through the glazing and when it is reflected from interior surfaces. It is intended to simulate the presence of lightweight objects that absorb solar radiation and rapidly convect heat to the air.

**masonry:** concrete, concrete block, brick, adobe, stone, and other similar materials.

**mass-area-to-glazing-area ratio:** the ratio of the total surface area of massive elements in a direct gain building to the total solar collection area. Massive elements included in this definition are all floors, walls, ceilings, or other interior objects with densities comparable to high-density concrete provided their surfaces are exposed and located in a room that is at least partially illuminated by direct solar gain.

**monthly calculation method:** application of the monthly solar load ratio correlations to a calculation of the monthly auxiliary heat. Also called the monthly SLR method.

**natural convection:** heat transfer between a surface and adjacent fluid (usually air or water), and by the flow of fluid from one place to another, both induced by temperature differences only rather than mechanical means. Also called free convection.

**net reference load:** steady-state heat loss from a building, excluding the solar wall, assuming constant indoor temperature, normally 65 degrees F.

**night insulation:** movable insulation that covers the solar aperture at night and is removed during the day.

**opaque:** not able to transmit light (for example, unglazed walls).

**projected area:** the principal net glazing area projected on a vertical plane.

**reference design:** a detailed specification of the passive solar features of a hypothetical passive solar building used as the subject of performance analysis.

**reference non-solar building:** a building similar to the solar building but with an energy-neutral wall in place of the solar wall and with a constant indoor reference temperature.

**reference temperature:** a fixed indoor temperature in the definition of the net reference load, usually 65 degrees F. Also the fixed indoor temperature in the reference non-solar building used in the definition of solar savings.  
**relative solar savings fraction:** a measure of comparison between two solar buildings.

**reverse thermo-circulation:** thermocirculation in the reverse direction; that is, from the heated space to the solar collector (sunspace or Trombe wall). This can occur at night when the heated space is warmer than the collector. It is assumed in the reference designs to be prevented by dampers.

**R-value:** the thermal resistance of a building element. **selective surface:** a surface with a high solar absorptance and a low infrared emittance (to reduce heat loss by infrared radiation).

**semi-enclosed sunspace:** a sunspace that shares three common walls with the associated building.

**solar absorptance:** the fraction of incident solar radiation that is absorbed upon striking a surface. The radiation not absorbed is reflected.

**solar aperture:** that portion of the solar wall covered by glazing.

**solar load ratio (SLR):** ratio of solar gain to building heat load used in SLR correlations.

**solar load ratio correlations (SLRC):** correlations between monthly solar savings fractions and monthly solar load ratios.

**solar radiation:** thermal radiation emitted by the sun including infrared radiation, ultraviolet radiation and visible light.

**solar savings:** the energy savings due to the solar system relative to the energy requirement of a reference non-solar building that has an energy-neutral wall in place of a solar wall.

**solar savings fraction:** the ratio of the solar savings to the energy requirement of the reference non-solar building.

**solar time:** time of day adjusted so that the sun is due south at noon (due north in the southern hemisphere).

**solar transmittance:** the fraction of solar radiation incident on a glazing that is transmitted through the glazing.

**solar wall:** the portion or portions of glazed walls where solar gains are accounted for.

**specific heat (c):** a measure of the ability of a unit of mass of material to store heat; namely, the heat stored in a unit of mass of material per degree of temperature rise (Btu/lb F).

**storage volume ratio:** ratio of the volume of thermal storage materials to the collection area (ft).

**sun-tempered building:** a minimal solar building derived from a conventional building by orienting its long axis east-west and placing a substantial fraction of its window area on the south side.

**temperature swing:** the range of indoor temperature in the building between day and night.

**thermal conductivity (k):** a measure of the ease with which heat flows in a material by conduction; namely the heat flow rate by conduction through a unit of distance in the material per unit of area per degree of temperature difference (Btu/h ft F).

**thermal radiation:** energy transfer in the form of electromagnetic waves from a body by virtue of its temperature, including infrared radiation, ultraviolet radiation, and visible light.

**thermal resistance:** a measure of the insulation value or resistance to heat conduction of a building element; namely, the reciprocal of the thermal conductance, also called the "R-value."

## FOR FURTHER INFORMATION

### CHAPTER 1. CLIMATE

A source of weather data for most locations in the world is the National Climatic Data Center, Federal Building, Asheville, North Carolina, 28801-2696, U.S.A. Telephone: 704-259-0682.

Tabel 1 in this publication is from *World-Climates* by Willy Rudloff, published in Stuttgart, Germany, 1981.

You should also check World Meteorological Organization publications and government military publications in your country.

### CHAPTER 2. FUNDAMENTALS

*ASHRAE Handbook of Fundamentals*, 1981, ASHRAE, 1791 Tullie Circle NE, Atlanta, Ga 30329.

Givoni, B., Man, *Climate and Architecture* (2nd Ed.), Applied Science Publishers Ltd., London (1976).

Fanger, P.O., *Thermal Comfort — Analysis and Applications in Environmental Engineering*, McGraw-Hill, New York, NY (1970).

Watson, D. (Ed.), *Energy Conservation Through Building Design*, McGraw-Hill, New York, NY (1979).

### CHAPTER 3. BUILDING COMPONENTS

Balcomb, J.D. , et al., *Passive Solar Design Handbook*, U.S. Department of Energy, Vol. II (1980) and Vol. III (1982).

Burch, D.M., et al., "A Field Study of the Effect of Wall Mass on the Heating and Cooling Loads of Residential Buildings," Proceedings of the Building Thermal Mass Seminar, Knoxville, TN (June 1982).

Clark, E. and Burdahl P., "Radiative Cooling: Resource and Applications", *Passive Cooling Handbook*, Proceedings of Passive Cooling Workshop, Fifth National Passive Conference, Amherst, MA (1980).

Fairey, P.W., "Effects of Infrared Radiation Barriers on the Effective Thermal Resistance of Building Envelopes", Proceedings of ASHRAE/DOE Conference on Thermal Performance of the Exterior Envelopes on Buildings, II. Las Vegas, NV (December 1982).

Fairey P.W., "The Thermal Performance of Selected Building Envelope Components in Warm, Humid Climates", Proceedings of the Sixth Annual Technical Conference of ASME Solar Energy Division, Orlando, FL (April 1983).

Givoni, B., "Cooling of Buildings by Passive Systems", Proceedings of the First International Passive and Hybrid Cooling Conference, Miami, FL (November 1981).

Labs, K., *Regional Analysis of Ground and Above Ground Climate*, Oak Ridge National Laboratory (December 1981).

Mazrai, E., *The Passive Solar Home Book*, Rodale Press, Emmaus, PA (1979).

Watson, D. and Labs, K., *Climate Design*, McGraw-Hill Book Company, New York, NY (1983).

#### CHAPTER 4. NATURAL VENTILATION

Akins, R.E., Peterka, J.A., and Cermak, J.E., "Average Pressure Coefficients for Rectangular Buildings", Proceedings, Fifth International Conference on Wind Engineering, Ft. Collins, CO, Pergamon Press, 1400 pp. (July 1979).

Arens, E., et al., *A New Bioclimatic Chart for Environmental Design*. Contact author at Department of Architecture, UC Berkeley, CA.

Arumi, F.N., "Computer-Aided Energy Designs for Buildings", *Energy Conservation Through Building Design*, Ed. Donald Watson, in An Architectural Record Book, McGraw-Hill (1979).

Aynsley, R.M., "Tropical Housing Comfort by Natural Airflow", *Building Research and Practice*, U.K., pp. 242-252 (July/August 1980).

Aynsley, R.M., "Wind Generated Natural Ventilation of Housing for Thermal Comfort in Hot Humid Climates", Fifth International Wind Engineering Conference (1979).

Aynsley, F.M., Melbourne, W., and Vickery, B.J., "Architectural Aerodynamics", *Applied Science*, London (1977).

Baer, S., *Cooling with Night Air*, Zomeworks Corporation, Albuquerque, NM (October 1981).

Baer, S., "Cooling with Night Air", *alternate Sources of Energy*, Vol. 41, pp. 22-26 (January/February 1980).

Baer, S., "Concentrating Skylights, Insulation and Ventilation", *Home Remedies - A Guidebook for Residential Retrofit*, Ed. Tom Wilson, Mid-Atlantic Solar Energy Association, Philadelphia, PA (1980).

Chandra, S. and Kerestecioglu, A.A., "Heat Transfer in Naturally Ventilated Rooms; Data from Full-Scale Measurements", FSEC-PF-45-83, ASHRAE semiannual meeting, Atlanta, GA (January 1984).

Crowther, R., "This Building is Loaded", *Progressive Architecture*, Vol. 4, pp. 150-155 (1980).

Dick, J.B., "The Fundamentals of Natural Ventilation of Houses", *Journal, Institution of Heating Ventilating Engineers*, pp. 123-132 (June 1950).

Evans, B.H., "Energy Conservation with Natural Air Flow Through Windows", *ASHRAE Transactions*, Vol. 85, part 2, pp. 641-650 (1979).

Evans, B.H., "Natural Air Flow Around Buildings", *Research Report #59*, Texas Engineering Experiment Station, TX, A&M College System (March 1957).

Fairey, P.W., and Bettencourt, W., "La-Sucka - A Wind Driven Ventilation Augmentation and Control Device", *Proceedings, International Passive and Hybrid Cooling Conference*, Miami Beach, FL (November 1981).

Fanger, P.O., *Thermal Comfort*, McGraw-Hill (1970).

Gadgil, A., "On Convective Heat Transfer in Building Energy Analysis", Ph.D. Thesis, Report LBL-10900, Lawrence Berkeley Labs (May 1980).

"Principles of Natural Ventilation", *Building Research Establishment Digest*, 210 (February 1978).

Reed, R.H., "Design for Natural Ventilation in Hot Humid Weather", Texas Engineering Experiment Station, reprinted from *Housing and Building in Hot-Humid and Hot-Dry Climates*, (1953).

Sobin, H.J., "Window Design for Passive Ventilative Cooling: An Experimental Model-Scale Study", *Proceedings: 1981 International*

Passive/Hybrid Cooling Conference, Miami Beach, FL, pp. 191-195  
(November 1981).

Soliman, B.F. and Frick, F.R., *Effect of Building Grouping on Wind Induced Natural Ventilation*, University of Sheffield, England.

Van Straaten, J.F., Roux, A.J.A., and Richards, S.J., "Comparison of the Thermal and Ventilation Conditions in Similar Houses Employing Different Ventilation Schemes", Bulletin No. 13, National Building Research Institute, South African Council for Scientific and Industrial Research (March 1955).

Van Straaten, J.F., *Thermal Performance of Buildings*, Elsevier Publishing Co., London, pp. 266-270 (1967).

## CHAPTER 5. AIR CONDITIONING

"A Field Study of Moisture Damage in Walls Insulated Without a Vapor Barrier", Final report from the Oregon Department of Energy, Oak Ridge National Laboratory, Union Carbide (May 1980).

Akridge, J.M., "Investigation of Passive Cooling Techniques for Hot-Humid Climates", Georgia Institute of Technology (1982).

Doderer, E., "Efficient Mechanical Dehumidification Through Sensible Cooling Recovery", Proceedings of ASME Heating and Cooling Systems Conference, Washington, DC (November 11-15, 1983).

"Energy Recovery Equipment and Systems", Air to Air, SMACNA - Sheet Metal and Air-Conditioning Contractors National Association, Inc. (July 1978).

Humphreys, W.E., "Condensation and Remedial Measures", Condensation in Buildings, edited by Derek J. Croome and A.F.C. Sherratt, Applied Science Publishers Ltd., London (1972).

Khattar, M.K., et al., "Impact of Fan Control Strategy on Air Conditioner Performance and Energy Requirement in Warm, Humid Climates", Proceedings of IASTED Energy '83 Symposium (November 19, 1983).

"Load Estimating - Part 1", *System Design Manual*, Carrier Air-Conditioning Company, Syracuse, NY (1960).

Manual H - "Heat Pump Equipment Selection and Application", Air-Conditioning Contractors of America (1977).

Manual J - "Load Calculation for Residential Winter and Summer Air Conditioning", Air-Conditioning Contractors of America (1981)

Manual N - "Load Calculation for Commercial Summer and Winter Air Conditioning (Using Unitary Equipment)", Air-Conditioning Contractors of America (1982).

Manual Q - "Equipment Selection and System Design Procedures for Commercial Summer and Winter Air Conditioning (using Unitary Equipment)", Air-Conditioning Contractors of America (1977).

Manual 9 - "Code and Manual for the Design and Installation of Warm Air, Winter Air-Conditioning Systems and Year-Round Air-Conditioning Systems", National Environmental Systems Contractors Association (1960).

## CHAPTER 6. BUILDING DESIGN

American Institute of Architects, "The House Beautiful Climate Control Project", reprinted from the *Bulletin of the American Institute of Architects* (1950).

Florida Solar Energy Center, "Design Notes and Energy Notes Series", FSEC-DN-1 to 8 and FSEC-EN-1 to 10.

Harvard University, "Plants for Passive Cooling", Department of Landscape Architecture, Graduate School of Design, Cambridge, MA, for Oak Ridge National Laboratory, Solar and Special Studios Section, Energy Division (April 1981).

Mazria, E., *The Passive Solar Energy Book*, Rodale Press, Emmaus, PA (1979).

National Association of Home Builders, "Cost Effective Site Planning", NAHB, Washington, DC (1976).

Southern Solar Energy Center, "Building with Passive Solar", SSEC for the Department of Energy (March 1981).

Southern Solar Energy Center "Solar Site Planning", SSEC for the Department of Energy (1981).

Olgay, V., *Design with Climate*, Princeton University Press, Princeton, NJ (1963).

Vieira, R., and Sheinkopf, K., *Energy-Efficient Florida Home Building*, Florida Solar Energy Center, Cape Canaveral, FL (1988).

Watson, D., *Energy Conservation Through Building Design*, McGraw-Hill Book Company (1979).

## CHAPTER 7. HOT WATER

American Society of Heating, Refrigerating, and Air-Conditioning Engineers, Inc., ASHRAE Handbook - 1980 Systems Volume, Chapter 37, Atlanta, GA (1981).

American Society of Heating, Refrigerating, and Air-Conditioning Engineers, Inc., ASHRAE Standard 90A-1980, "Energy Conservation in New Building Design", Atlanta, GA (1980).

Chandra, S., Ventre, G.G., and LaHart, D.E., "A Guide for Sizing Solar Water Heaters in Florida", Florida Solar Energy Center, Cape Canaveral, FL (June 1981).

Cromer, C., "Sizing and Matching a Photovoltaic Circulation System with a Solar Domestic Hot Water System", Proceedings of Fifth Annual Technical Conference: American Society of Mechanical Engineers, Solar Energy Division, Orlando, FL (April 1983).

Energy Office, County of San Diego, California, "A Comparison of Solar and Natural Gas Water Heating System Performance in San Diego County", CA (December 1981).

Goodman, R., "Reduced Energy Consumption of Automatic Washers - Benefits and Penalties", Proceedings of the Conference on Major Home Appliance Technology for Energy Conservation, U.S. Department of Energy, West Lafayette, IN (February 1978).

Grot, R.A., "Field Performance of Gas and Electric Water Heaters", Proceedings of the Conference on Major Home Appliance Technology for Energy Conservation, op. cit.

*Hot Water Manual*, compiled by Rheem Australia Limited, Australia (February 1979).

Johnson, W., "Solar-Powered Freeze Protection", *Solar Engineering and Contracting*, Troy, MI (March/April 1983).

Merrigan, T., "Residential Conservation Demonstration: Domestic Hot Water Final Report", Florida Solar Energy Center, Cape Canaveral, FL (September 1983).

Rohles, F.H. and Konz, S.A., "Showering Behavior: Implications for Water and Energy Conservation", *ASHRAE Transactions*, 1982 Semiannual Meeting, Houston, TX (January 1982),

Root, D.E., and Ventre, G.G., *Solar Water and Pool Heating Manual*, Florida Solar Energy Center, Cape Canaveral, FL (November 1982).

U.S. Department of Housing and Urban Development, "Minimum Property Standards for One- and Two-Family Living Units".

University of Wisconsin Solar Energy Laboratory, "FCHART: A Design Program for Solar Heating Systems. Version 4.1 User's Manual", Madison, WI (June 1982).

## CHAPTER 8. PHOTOVOLTAICS

Buresch, M., *Photovoltaic Energy Systems: Design and Installation*, McGraw-Hill Book Company (1983).

Davidson, J. and Komp, R.J., *The Solar Electric Home*, AATEC Publications, Ann Arbor, MI (1983).

Jones, G.J., and Thomas, M.J., "Grid Connected PV Systems: Are They Worth It?", *Photovoltaics International*, Vol. 1, No. 3, Phoenix, AZ (August/September 1983).

Kern, E.C, and Pope, M.D., "Development and Evaluation of Solar Photovoltaic Systems: Final Report", MIT Lincoln Laboratory, Lexington, MA (June 1983).

Russell, M.C., "An Apprentice's Guide to Photovoltaics", *Solar Age*, 6 (7): 45-51 (July 1981).

Russell, M.C., "Photovoltaic System Evaluation at the Northeast Residential Experiment Station, November 1980 - May 1982, Final Report", MIT Lincoln Laboratory, Lexington, MA (January 1983).

Strong, S., "PV: An Architect's View", *Photovoltaics International*, Vol. 1, No. 3, Phoenix, AZ (August/September 1983).



## SOLAR ENERGY INDUSTRIES ASSOCIATION

Since 1974, the Solar Energy Industries Association (SEIA) has served industry as the national trade association for the solar thermal, solar electric, and passive solar manufacturers, distributors and component suppliers. Through its technical divisions, councils, and state chapters, SEIA conducts a broad range of activities for its members, including government relations, policy and regulatory development, research analysis, statistical reporting, marketing and public relations programs, export assistance, educational and promotional publications, and other programs related to building the solar industry in the United States and abroad. SEIA has historically played a very active and vital role in the political process, promoting the implementation of policies and legislation to support solar energy technology. The Solar Energy Industries Association works closely with federal agencies and national trade organizations, actively representing all facets of the solar energy and energy conservation fields.

*Kenneth Sheinkopf*, who compiled and edited this book, is Director of Special Projects for the Solar Energy Industries Association. He joined the Florida Solar Energy Center (FSEC) in 1983, and has served as the Center's Director of Continuing Education and Manager of Information Services. He is currently Director of Governmental Relations for FSEC. He has worked closely with the FSEC research staff on several major projects in passive design, and has given talks on all aspects of solar energy to more than 100 meetings throughout the world. He is the author or co-author of several books, including *Energy-Efficient Florida Home Building*, and more than 50 journal articles and professional presentations. He serves on the Board of Directors of the Buildings Division of the American Solar Energy Society. Since 1986, he has written a weekly column for FSEC on energy conservation and home comfort, currently carried by 20 Florida newspapers.

