

Power Supply Ramp Control in the APS Booster Synchrotron*

J.A. Carwardine and S.V. Milton

Advanced Photon Source, Argonne National Laboratory
9700 South Cass Avenue, Argonne, Illinois 60439 USA

RECEIVED

JUN 23 1996

OSTI

Abstract

The Advanced Photon Source (APS) booster ramp cycle is completed within 250ms and repeated at 2Hz, accelerating positrons from 400MeV to 7GeV. Phase-controlled power supplies deliver current to each of the dipole, quadrupole, and sextupole magnet families. In order to maintain constant transverse tunes and chromaticity while the beam is accelerated, quadrupole and sextupole magnet currents must closely track the current in the dipole magnets. This is achieved using a conventional regulator in the power supply together with cycle-cycle corrections applied to the reference waveforms. The system and its performance is described and tuning algorithms are discussed.

1 INTRODUCTION

The APS booster uses a simple FODO magnet lattice consisting of 68 dipole, 80 quadrupole, and 64 sextupole magnets. The quadrupole magnets are connected in chains of 40 magnets creating 'focusing' and 'defocusing' families. Sextupoles families are connected as 32 magnets per family. The power supplies are based around a 12-pulse group of wye-connected thyristor-controlled rectifiers [1].

In order to meet the accelerator requirements, current is ramped at ~4A/ms in the dipole magnets and at ~2.5A/ms in the quadrupole magnets. Beam is injected at a dipole current of ~50A and extracted at ~900A corresponding to energies of 400MeV and 7GeV, respectively; the ramp is linear throughout the acceleration cycle. Tracking and stability specifications for the power supplies are derived from the stability requirements of the transverse tunes in the accelerator. Tolerances are defined in terms of the slope and zero-intercept time of a linear fit to the output current and in terms of the Δ/I error within each cycle. The target worst-case errors for dipole and quadrupole magnets obtained by this analysis are given in Table 1.

Table 1: Target Errors for Dipole and Quadrupole Magnets

Linear Fit Characteristic	Nominal Value*	Worst Case Error
Ramp Δ/I (%)	0.0	0.1
Ramp Slope (A/ms)	2.49	0.003
Zero Crossing (ms)	7.1	0.018

*Focusing Quadrupole

*Work supported by U.S. Department of Energy, Office of Basic Energy Sciences, under Contract No. W-31-109-ENG-38.

2 CONTROL OVERVIEW

As explained in [1], the tracking and stability requirements cannot be met using a conventional power supply regulator alone because of power supply transients and limitations in the available bandwidth from both the power circuit and the load inductance. However, for a given reference waveform, the output current is very repeatable from cycle to cycle, so errors can be used to update the reference waveforms for future cycles. At APS, updates are applied to the reference waveform shape in order to improve the ramp linearity and to the reference waveform amplitude and trigger time in order to compensate for drift.

Each power supply can operate either in voltage or current mode; in both cases the objective being to control the output current. In voltage mode the power supply regulates the voltage across the load and the computer-based control system ensures that the appropriate output current is produced. In current mode, the power supply is also given the current reference waveform which the regulator attempts to follow. In both modes updates are applied to the voltage reference waveform to correct for residual errors in the output current.

Great care has been taken to ensure clean current monitoring which is crucial to the success of this system. Both reference waveforms and measured currents are digitized to 16 bits with greater than 14 bits of usable signal.

Stability and tracking requirements have been met using voltage mode; this is the standard configuration when running beam. Current mode is in the commissioning phase; it provides even greater stability and simplifies the process of running different ramping profiles.

3 VOLTAGE MODE

In this mode the power supply regulator attempts to control the voltage across the magnet according to the supplied reference waveform. The control system is responsible for generating and maintaining the required output current. The control scheme is shown in Figure 1.

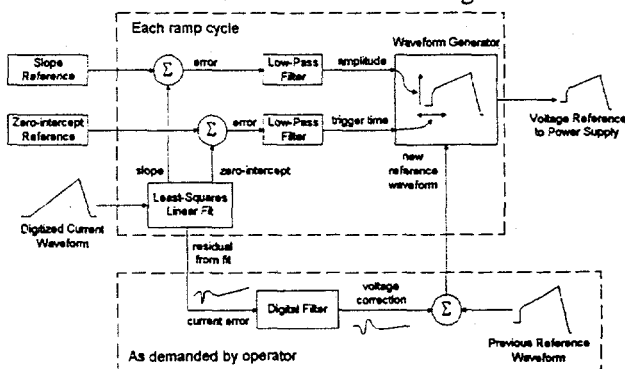

Figure 1: Control Scheme for Voltage Mode

DISCLAIMER

**Portions of this document may be illegible
in electronic image products. Images are
produced from the best available original
document.**

DISCLAIMER

This report was prepared as an account of work sponsored by an agency of the United States Government. Neither the United States Government nor any agency thereof, nor any of their employees, makes any warranty, express or implied, or assumes any legal liability or responsibility for the accuracy, completeness, or usefulness of any information, apparatus, product, or process disclosed, or represents that its use would not infringe privately owned rights. Reference herein to any specific commercial product, process, or service by trade name, trademark, manufacturer, or otherwise does not necessarily constitute or imply its endorsement, recommendation, or favoring by the United States Government or any agency thereof. The views and opinions of authors expressed herein do not necessarily state or reflect those of the United States Government or any agency thereof.

At the end of each cycle, a least-squares linear fit is applied to the measured current waveform from each magnet family. Deviations from the required slopes and zero-intercepts are corrected automatically by adjusting the amplitude and trigger time of each voltage reference waveform reducing the effect of slow drift in the power supplies, AC power line, and magnet systems. The bandwidth for these control loops is limited to around 1/10 per cycle in order to filter out random fluctuations.

Figure 2 shows the slope and zero-intercept for the focusing quadrupole magnets over a 24-hour period. Residual errors are dominated by random fluctuations with drift being eliminated by the cycle-cycle feedback.

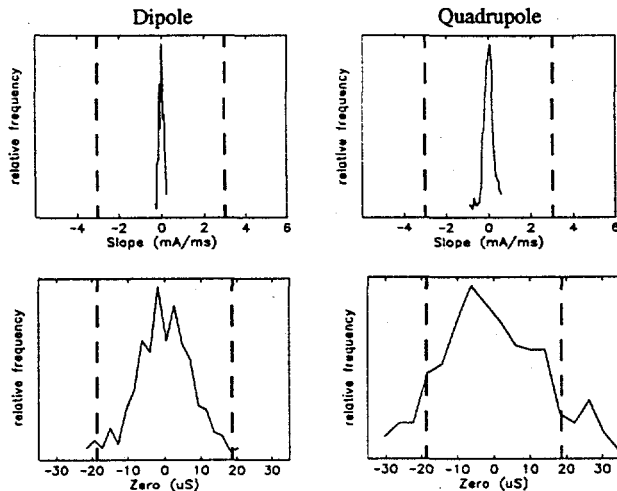

Figure 2: Deviations from Nominal Values over 24 Hours (dotted lines indicate target worst-case errors)

The same data is shown as a histogram in Figure 3 along with the equivalent dipole parameters. The larger magnet inductance helps to stabilize the dipole parameters.

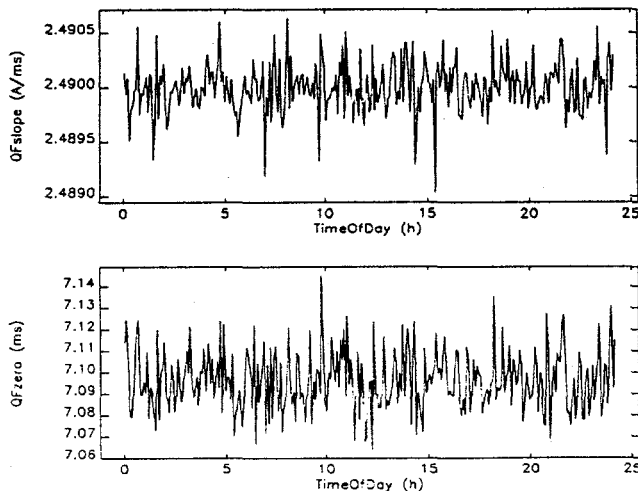

Figure 3: Measured Ramp Stability over a 24-hour Period

The stability of the slopes is well within target performance for all the magnets and, for the zero-intercepts, meets target performance 90% of the time.

It has been found that the ramp tracking is very stable when the cycle-cycle feedback is active, and frequent

updates to the reference shape have been unnecessary (often, no updates are needed over a period of many days).

4 CURRENT MODE

In this mode the power supply receives both voltage and current reference waveforms. The power supply regulator has two nested loops where the outer loop controls current and drives an inner voltage loop. The voltage reference provides feedforward to this inner loop.

The attraction of current mode is that it can dynamically reduce errors within each cycle thereby improving the cycle-cycle stability, whereas the computer control system can at best only operate on the next cycle.

The computer control system performs the same tasks as in voltage mode; cycle-cycle drift is managed by adjustments to the amplitude and trigger time of the voltage reference waveform, and residual errors in the output current are used to update the voltage reference shape. Changing the amplitude and trigger time has a different effect compared with voltage mode; the trigger time has the most effect early in the ramp, and the amplitude changes the later part of the ramp. These effects are coupled and tend to fight each other. In the future the influence matrix will be diagonalized and the algorithm modified to operate correctly on the relevant eigenmodes.

About a factor two improvement in cycle-cycle stability is obtained over voltage mode. Histograms of short-term stability for the two modes is shown in Figure 4. This data was taken over a 15-minute period; in voltage mode cycle-cycle feedback on and in current mode cycle-cycle feedback off.

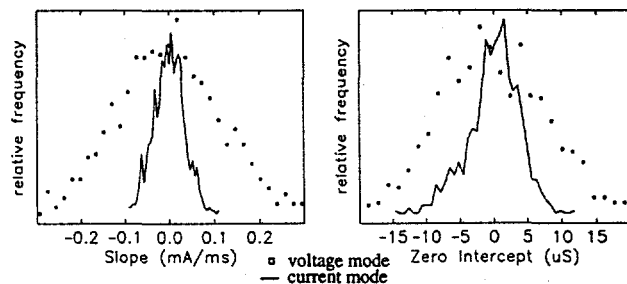

Figure 4: Deviations from Nominal Values for Quadrupole

Long-term drift is also improved in current mode and, even with cycle-cycle feedback off is comparable to that achieved in voltage mode with the cycle-cycle feedback active. Significant improvements are anticipated once the cycle-cycle feedback is operational for current mode.

5 RAMP TUNING

Ideally the voltage reference waveform would be the $'Ldi/dt + iR'$ voltage needed to drive the output current at a constant rate of rise through the magnet load. In practice, it is necessary to modify this ideal voltage reference in order to compensate for the actual response of the power supply. Ramp tuning involves measuring the output current error and using it to generate a small voltage correction which is

added to the voltage reference waveform. The process is repeated until errors are within tolerance [2].

In order to generate a voltage correction signal from a current error, a model is required of the inverse of the system response of the output current to a change in the voltage reference. In voltage mode, the system is modeled as a single pole (originating from the load), and the inverse model is a single zero together with an empirically determined time delay (added to compensate for oversimplification of the forward model).

Once tuned, ramp quality is very stable over time provided that the cycle-cycle feedback is active, and original intentions to implement frequent automatic ramp tuning have been unnecessary. Figure 5 shows the measured peak $\Delta I/I$ for the quadrupole magnet over a 24-hour period.

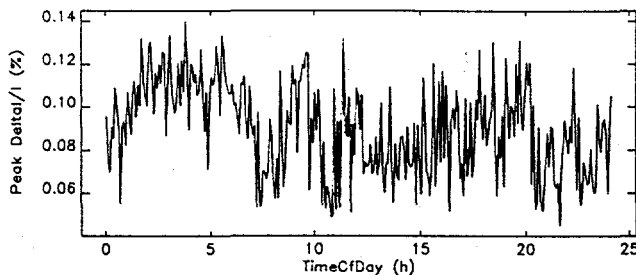

Figure 5: Peak Quadrupole $\Delta I/I$ over a 24-hour Period

The response characteristics are significantly different in current mode, and the same model cannot be used for tuning the ramps. A very simple first-order model is to generate the voltage correction from a scaled version of the current error. However, this model is only marginally stable and oscillations appear at the start of the ramp if too many corrections are applied. Nevertheless, adequate ramps have been successfully tuned using this algorithm.

6 SYSTEM IDENTIFICATION

In order to improve the forward and inverse models of the system for the ramp-tuning algorithms, attempts have been made to measure the small-signal response of the current to a change in the voltage reference. This is complicated by the need to complete each measurement within the acceleration part of the ramp cycle (220ms) and by having to avoid disturbing the current at the peak of the ramp, since this affects the starting point for the next cycle.

Frequency response measurements have been made by applying small sinusoids to the voltage reference waveform and fitting a sinusoid of the appropriate frequency to the current difference. The results are shown in Figure 6. The technique works well above a few tens of Hertz but measurements below 20Hz are difficult to make. The technique has good frequency resolution and has identified a null in the response at 180Hz caused by the power circuit. The problem is to identify the low frequency response which is needed to generate a ramp-tuning algorithm.

An alternative is to add a small zero-mean random signal to the reference waveform and measure the resulting change in output current. Using least-squares correlation

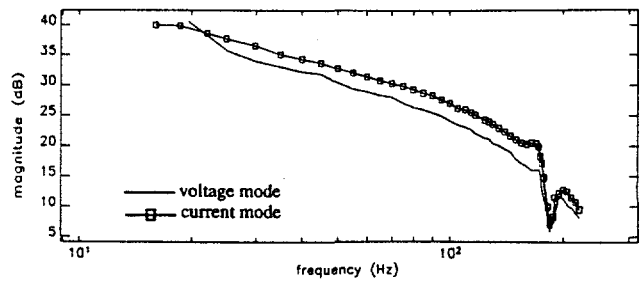

Figure 6: Frequency Response Measured using Sinewaves

techniques such as Wiener Filter or Prediction Error Filter design [3], both forward and inverse models can be generated. The advantages of this approach are that a complete measurement can be made in a single cycle and that the time-domain response is generated directly. Impulse responses from an FIR Wiener design are shown in Figure 7 and the corresponding frequency responses in Figure 8.

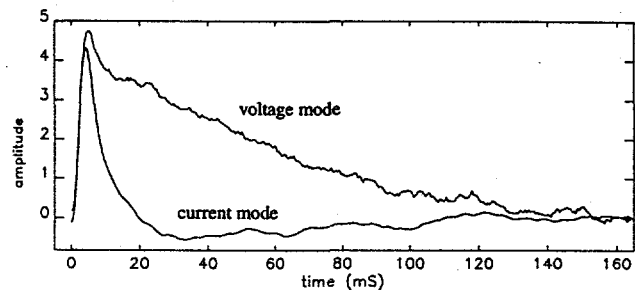

Figure 7: Impulse Response of Wiener Filter Forward Models

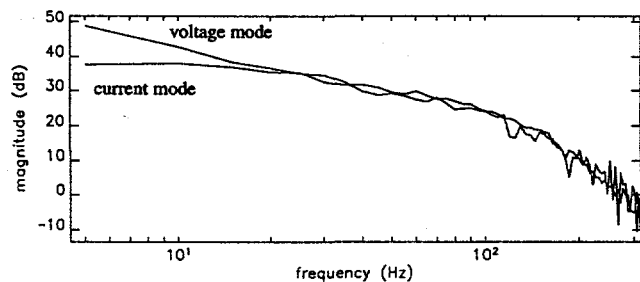

Figure 8: Frequency Responses of Wiener Filter Models

Inverse models generated using these techniques are to be incorporated into the ramp-tuning algorithms.

7 REFERENCES

- [1] J. Carwardine, S. Milton, D McGhee, "Performance of the Ramping Power Supplies for the APS Booster Synchrotron," Proc. of the 1995 PAC, Dallas, TX, USA, pp. 1967-1969 (1996).
- [2] S. Milton, J. Carwardine, "Ramp Tuning of the APS Booster Synchrotron Magnet Power Supplies," Proc. of the 1995 PAC, Dallas, TX, USA, pp. 2708-2710 (1996).
- [3] J. Proakis, D. Manokolis, "Digital Signal Processing," Macmillan Publishing, 1992.