

DISCLAIMER

This report was prepared as an account of work sponsored by an agency of the United States Government. Neither the United States Government nor any agency thereof, nor any of their employees, makes any warranty, express or implied, or assumes any legal liability or responsibility for the accuracy, completeness, or usefulness of any information, apparatus, product, or process disclosed, or represents that its use would not infringe privately owned rights. Reference herein to any specific commercial product, process, or service by trade name, trademark, manufacturer, or otherwise does not necessarily constitute or imply its endorsement, recommendation, or favoring by the United States Government or any agency thereof. The views and opinions of authors expressed herein do not necessarily state or reflect those of the United States Government or any agency thereof. Reference herein to any social initiative (including but not limited to Diversity, Equity, and Inclusion (DEI); Community Benefits Plans (CBP); Justice 40; etc.) is made by the Author independent of any current requirement by the United States Government and does not constitute or imply endorsement, recommendation, or support by the United States Government or any agency thereof.

Final report for Interdisciplinary seed grant 2024-2025

1. Cover Page

1.1 Project Title:

Computational Analysis and Optimized Modeling of Geomagnetically Induced Currents in Power Transformers

1.2 Principal Investigators:

Pablo Gomez, Professor, Electrical and Computer Engineering

Richard Meyer, Associate Professor, Mechanical and Aerospace Engineering

1.3 Date of submission:

04/30/2025

2. Introduction

2.1 Background and context

A **Geomagnetic storm** is a type of space weather event in which the Earth's magnetic field interacts with magnetic solar material (see Fig. 1) [1], [2], [3]. This interaction produces variations in the Earth's magnetic field that result in corresponding variations in the electric field according to Faraday's law. When these fields interact with long conducting paths, such as power lines, pipelines, or railways, they produce what is known as **Geomagnetically induced currents (GIC)** [2]. Fig. 2 illustrates the flow of GICs in an electric power transmission system [1].



Fig. 1 Illustration of geomagnetic storm (extracted from [3])

GIC can affect various electric power grid components such as transformers, generators, protection devices, communication systems, etc. [3]. Depending on the severity and duration of a geomagnetic storm, the effects of GIC can range from minor fluctuations in the power grid, to malfunctioning of protection devices, damage of grid components, and even complete power outages [4]. The most critical and costly piece of grid infrastructure affected by GIC is the power transformer [5]. **Power transformers** are essential devices of the power grid responsible for modifying voltage levels so that electric energy can be efficiently transmitted, distributed, and utilized. Step-up transformers increase the level of the voltage generated by power plants so that electricity can be transmitted with the maximum possible efficiency by long high voltage transmission lines. On the other hand, step-down transformers reduce the voltage to the levels of utilization by industrial, commercial, and residential consumers.

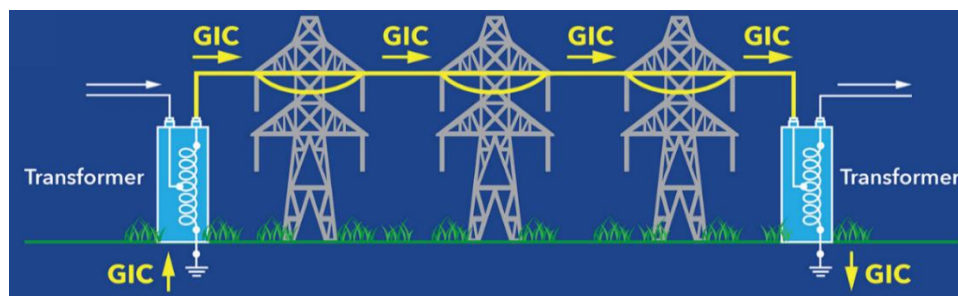

Fig. 2 Geomagnetically induced currents (GIC) flowing through transmission lines and impacting power transformers (extracted from [1])

2.2 Objectives

In this project we aim to **better understand the effect of geomagnetically induced currents (GIC) on power transformers**. Expanding upon our previous work [6] focused on producing a

methodology for accuracy-enhanced computation of GIC signatures (i.e., time-domain current magnitude variation for the event duration) from a combination of physics-based and data-driven computational tools, we propose the use of these GIC signatures as inputs for a physically-detailed and optimized model of the power transformer to investigate how GIC determination and transformer modeling influence the evaluation of GIC effects on the transformer operation, as well as in its interaction with the power grid.

3. Methodology / Changes

The proposed methodology, illustrated in Fig. 3, involves the following tasks:

3.1 Task 1: Evaluation of GIC signatures

This project relies on preliminary work aimed at the development of a physics-based and data-driven methodology for the calculation of GIC signatures. Although GIC measurements are available in the literature for validation, further work is needed to ensure that the GIC signatures are not only accurately computed, but also compatible with the transformer modeling approach followed in this project. This involves evaluating the characteristics of the GIC signatures to understand how magnetic field fluctuations can affect the transformer.

Data analysis/evaluation: Time windows in the order of 12 to 24 hr. during geomagnetic storm events are considered for this part of the study, with Earth’s magnetic field data obtained from the International Real-time Magnetic Observatory Network [7], Earth conductivity profiles from US Geological Survey [8], and electric grid topology information from existing test cases provided for research purposes [9].

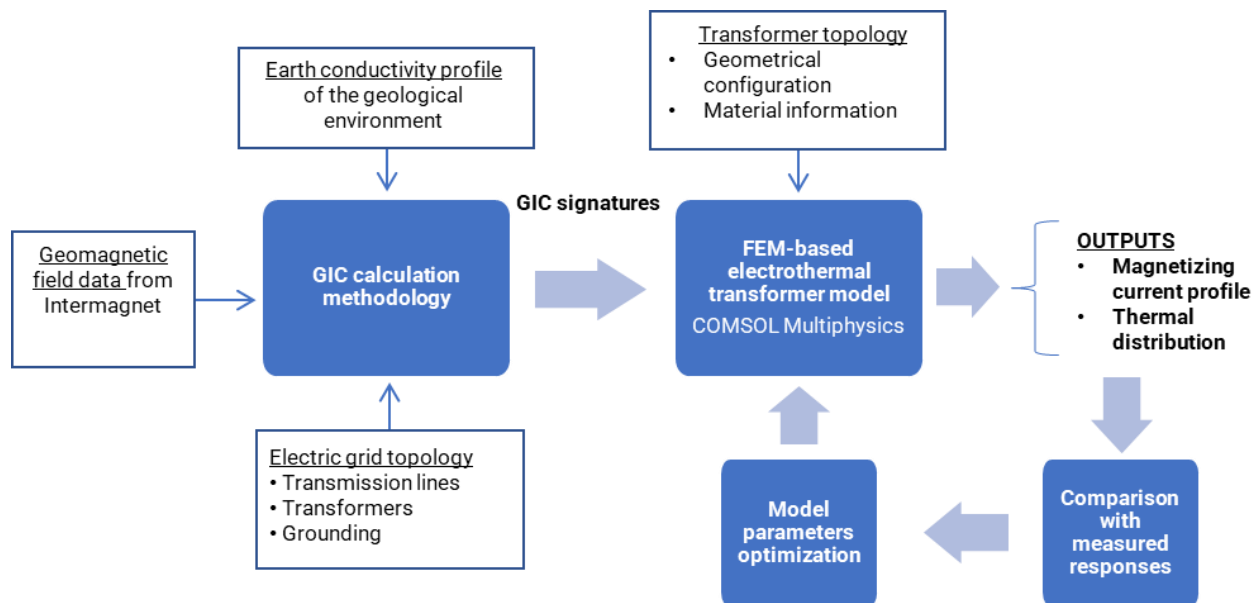

Fig. 3 Proposed methodology flowchart.

Changes: A significant GIC event occurred in May of 2024. Thus, besides the well-known event of Halloween 2003, we used data from 2024 and compared the impacts of these two datasets.

3.2 Task 2: Transformer modeling and parameter optimization for GIC

Once a transformer modeling baseline is identified from the studies performed in Task 1, it is used to implement a finite element model using software COMSOL Multiphysics.

Data analysis/evaluation: We utilized a real substation transformer topology obtained from [11], which lists all geometrical and electrical parameters of the transformer. The correct behavior of the transformer in a time-dependent FEM simulation is assessed starting with a power frequency analysis at the nominal power rating of the transformer, followed by a low frequency test (since GIC is a low frequency phenomenon), and then excited by a GIC profile obtained from admittance matrix calculation of the grid topology as explained in [6].

Changes: It was noted early in the project that a better interaction between the transformer model in COMSOL and the grid model in MATLAB was needed for an accurate prediction of GIC currents in the primary and secondary sides of the transformer. With this in mind, the optimization efforts were shifted into the development of a method that allows integrating the grid model and the GMD sources directly in COMSOL, resulting in a more realistic evaluation of the GIC effects on the transformer while connected to the power grid.

3.3 Task 3: GIC parameter sensitivity analysis

This task is focused on studying the effect of the following essential parameters on the severity of GIC effects on the transformer:

- a) the magnetic field profile during a magnetic storm event,
- b) the ground conductivity profile at the grid location,
- c) the type and materials of the transformer under test, and
- d) the topology of the grid exposed to the geomagnetic storm (e.g., transmission lines configuration, system grounding, interconnections, etc.)

Data analysis/evaluation: Our plan is to evaluate two or more sites during different geomagnetic storm events, with distinct ground conductivity conditions, grid topologies and transformer configurations. The results of this sensitivity analysis will serve to achieve our research objective to better understand how the aforementioned parameters impact the severity of GIC in power transformers.

Changes: We focused mainly on items a and b from the list above. For item a, as explained before, we considered 2 events from 2003 and 2024. For item b, rather than only considering different soil profiles, we have also evaluated the effect of different soil models. Item c was not explored due to data availability issues. For item d, rather than considering different grid topologies, we explored a more realistic way to introduce the grid topology and excitations into the FEM model for transformer GIC studies.

4. Results

4.1 Task 1: Evaluation of GIC signatures

This task was successfully completed. Considering the recent geomagnetic storm of May 10-11, 2024 [10], we compared this event to the baseline event of Halloween 2003, which was previously used in our GIC research. We also considered different locations (Washington, USA; Arizona, USA; and Ottawa, Canada) for the recent (2024) event. Finally, we evaluated the effect of the angle of the transmission line affected by GIC with respect to a reference position. Sample results of these comparative evaluations are shown in Figs. 4 to 6. These results were obtained using the same simplified transmission system considered in our previous work [6], shown in Fig. 7.

4.2 Task 2: Transformer modeling

This task was also completed, although the optimization portion was not explored in detail. A power transformer was selected based on [11]. This is a 31.5 MVA, 132 kV/33 kV, 60 Hz, star-delta power transformer with concentric windings, with the main dimensions shown in Fig. 8. Since saturation is a fundamental aspect for GIC studies, a nonlinear core model is considered, emulating the BH characteristics of silicon steel 30RK100 [12], as shown in 9.

A finite element model of the transformer was implemented in software COMSOL Multiphysics. This model is presented in Fig. 10. The model considers only one leg of the transformer, since the effect of GIC is expected to be very similar for all 3 phases. Initially, the model was tested under nominal power and frequency conditions to assess its proper performance in the time domain. Voltage and current waveforms obtained under these conditions are shown in Fig. 11. It can be observed that the magnitudes of these waveforms match the following analytical calculations:

$$V_p = 132 \text{ kV} \sqrt{2/3} = 107.78 \text{ kV}$$
$$V_s = \left(\frac{N_s}{N_p} \right) V_p = \left(\frac{433}{1000} \right) 107.78 \text{ kV} = 46.67 \text{ kV}$$

For a load impedance Z_L of 100 Ω :

$$I_s = \frac{V_s}{Z_L} = \frac{46.67 \text{ kV}}{100 \Omega} = 466.67 \text{ A}$$
$$I_p = \left(\frac{N_s}{N_p} \right) V_s = \left(\frac{433}{100} \right) (466.67 \text{ A}) = 202.1 \text{ A}$$

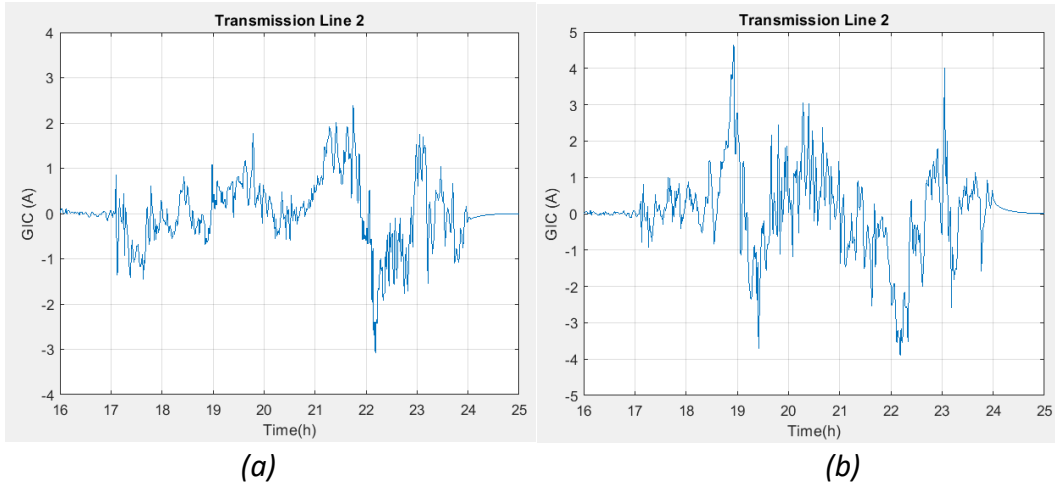

Fig. 4 GIC obtained for two different locations during the May 2024 event: (a) Newport, USA, (b) Ottawa, Canada

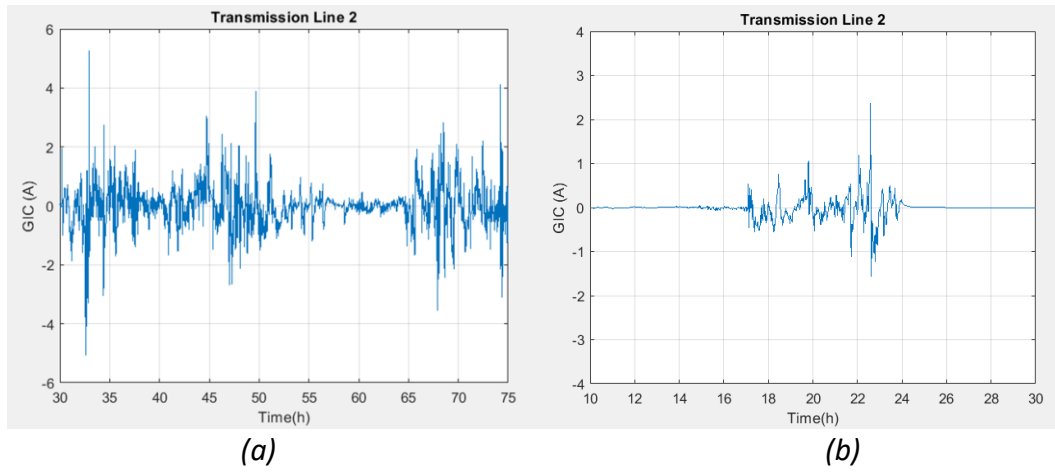

Fig. 5 GIC obtained for two different locations and two different events: (a) Halloween 2023, Newport, USA, (b) May 2024 event, Tucson, USA

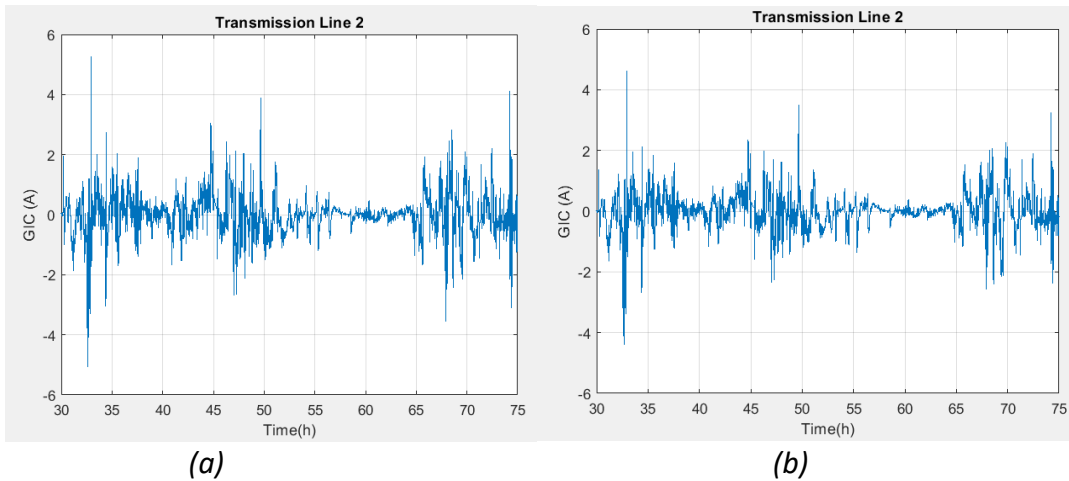

Fig. 6 GIC obtained for two different angles of coupling between the electric field from the geomagnetic event and the transmission line: (a) 45 degrees, (b) 60 degrees

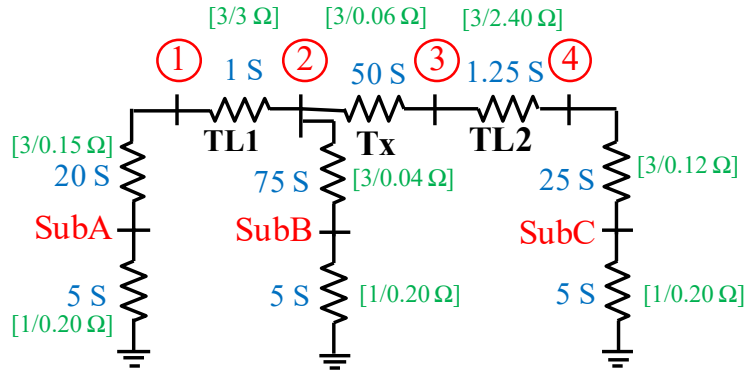

Fig. 7 Equivalent conductance circuit of test grid.

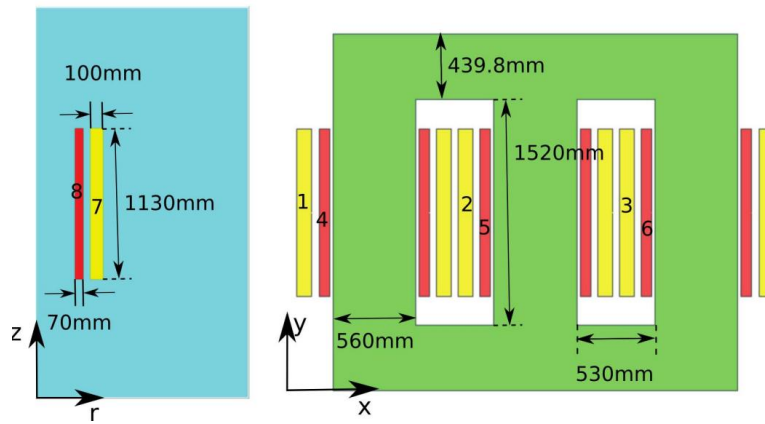

Fig. 8 Main geometrical data of the power transformer under study [11].

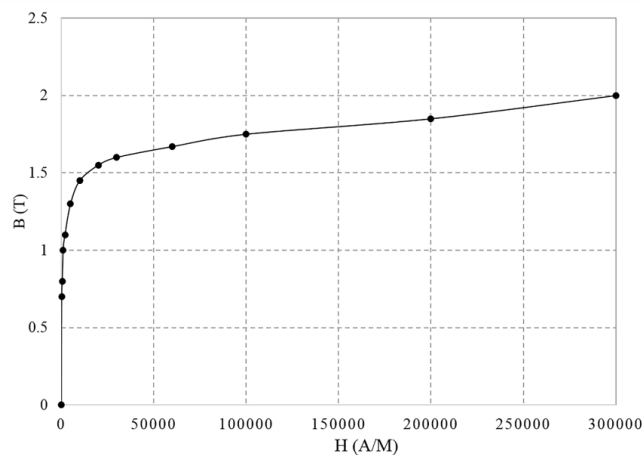

Fig. 9 BH curve of silicon steel 30RK100 [12].

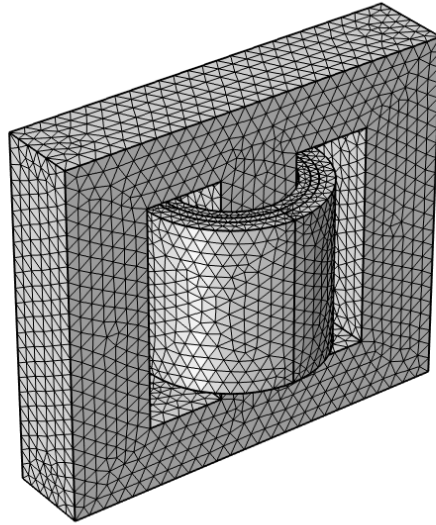
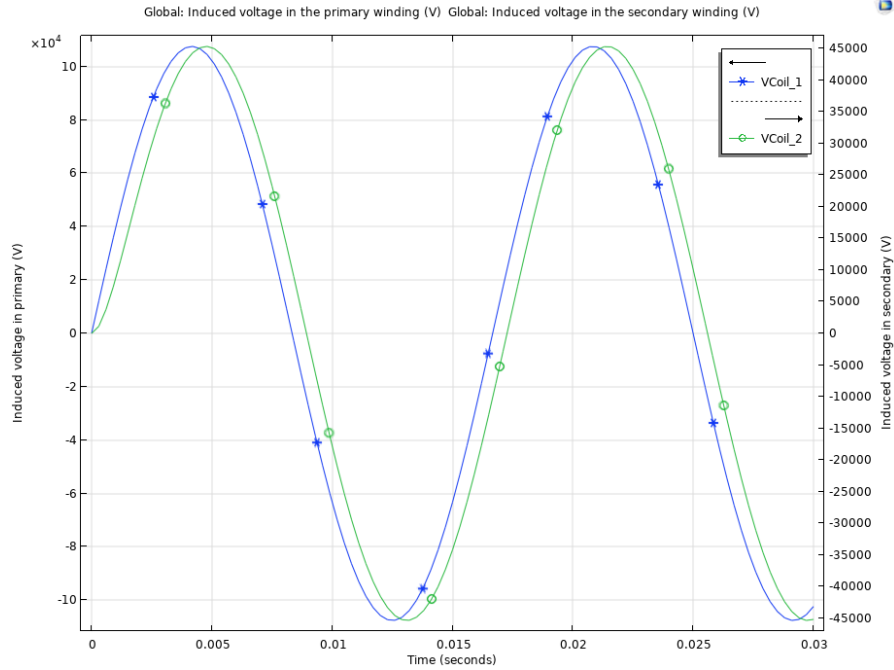

Fig. 10 Simplified FEM model of the transformer under study (for one leg).

Furthermore, the effect of the geomagnetic event on the transformer was evaluated by introducing the resistive elements of the grid topology into COMSOL using its circuit interface feature, which resulted in the circuit shown in Fig. 12. The voltage sources V1 and V2 are obtained from the electric field distribution along the two transmission lines on either side of the transformer, previously computed from a COMSOL soil model excited from real magnetic field data from Intermagnet [6].

Figures 13 and 14 show the profiles of current and voltage measured at the primary and secondary coils during the 2024 GMD event at the Newport, WA location. Although the voltages are very low compared to nominal values, the currents obtained reach peak values of approx. 10 A in the primary and 30 A in the secondary, approx. 7% and 9.4% of the primary and secondary nominal currents. These values superimposed with the nominal currents could take the transformer into saturation, although more studies are needed to evaluate this in detail. Fig. 15 shows the distribution of magnetic flux density in the transformer core during the peak time of the geomagnetic event. The highest value obtained is 0.9 T, which is close to the saturation point around 1.1 T according to Fig. 9, noting that this field is due only to GIC without the contribution of the nominal currents at power frequency.



(a)

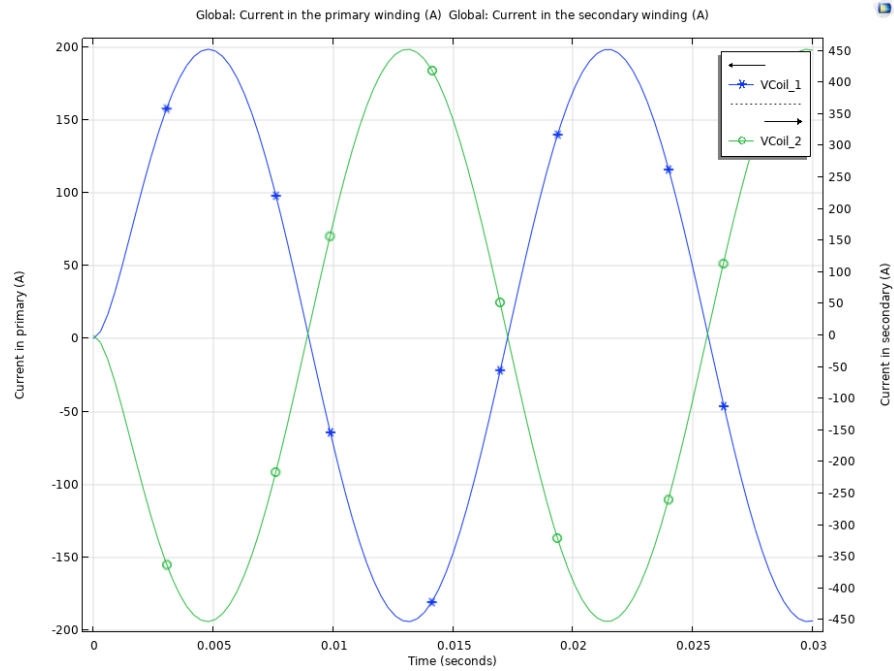

(b)

Fig. 11 Time domain response of the FEM transformer model for a load of 100 ohms: (a) voltages, (b) currents.

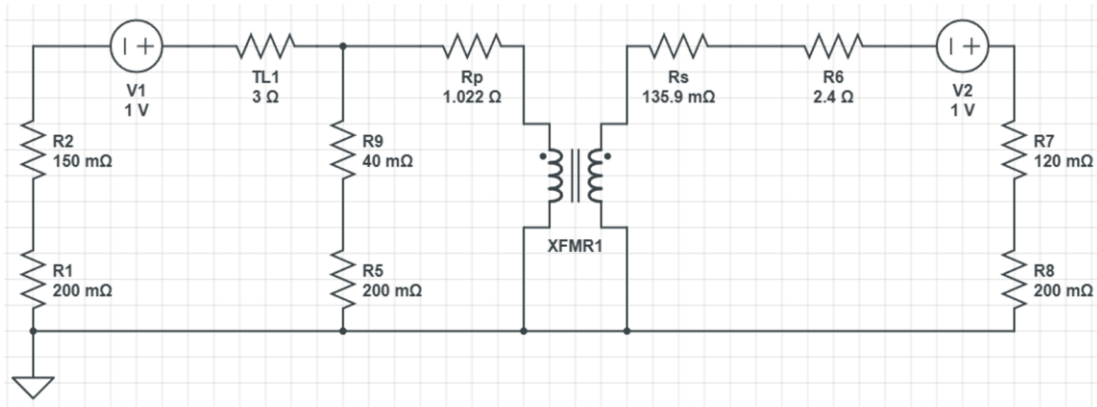

Fig. 12 Circuit representation of the grid model under test as implemented in COMSOL using electrical circuit interface.

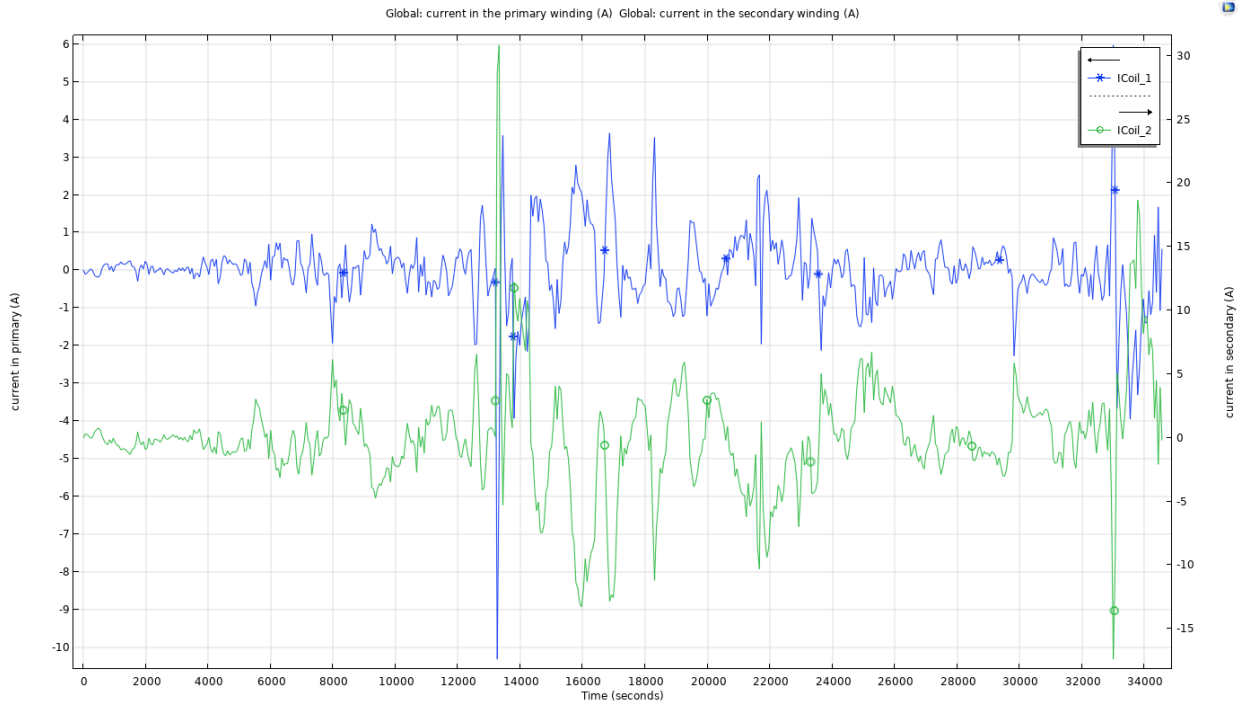

Fig. 13 Primary (blue) and secondary (green) currents during GMD event. (Note: left y-axis indicates primary currents, while right y-axis indicates secondary currents)



Fig. 14 Primary (blue) and secondary (green) voltages during GMD event. (Note: left y-axis indicates primary currents, while right y-axis indicates secondary currents).

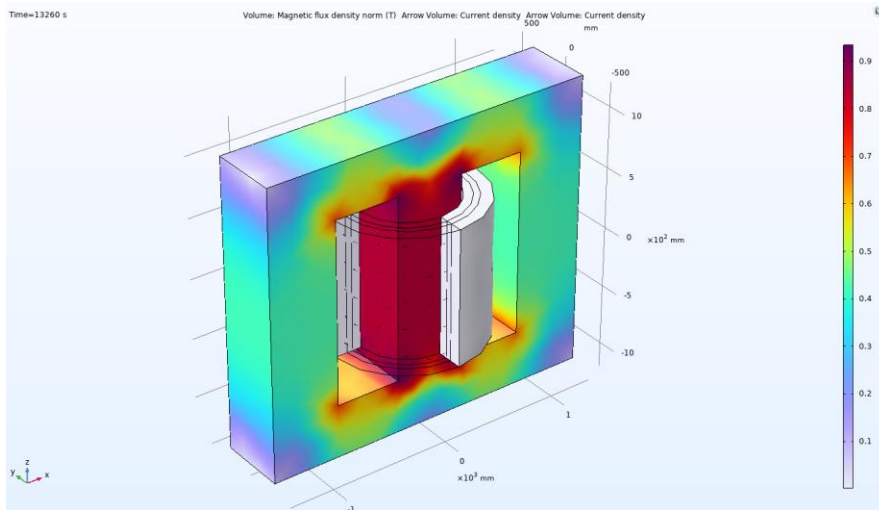

Fig. 15 Distribution of magnetic flux density (Teslas) in the transformer at the time of maximum GIC current.

4.3 Task 3: Sensitivity analysis

At the time of completion of this report, this task was still in progress as part of the thesis of an MS student. This work involves considering the effect of using a soil model with three layers instead of the two layers considered so far, as well as considering a soil model corresponding to a different location (with different depths and conductivities for each layer).

5. Challenges and Solutions

Availability of detailed transformer data is very limited due to manufacturer confidentiality. Fortunately, we were able to locate a paper with real substation transformer information, but tests for other geometries were not possible due to this restriction.

Going from a FEM transformer model operating at nominal frequency (with a time window of 30 ms) to a model excited by the GMD phenomenon (represented by voltage sources in series with transmission line resistances) required substantial time and effort, considering simulation time windows of more than 30000 seconds. This represented a 1-million times larger time window compared to the initial tests, which required several weeks of fine-tuning the simulation settings in terms of time-stepping and adaptive meshing, so that the results had sufficient accuracy while minimizing the simulation times and overall computational effort.

A nontechnical challenge of this project was finding the right student to support the work, and a steep learning curve of the methods and tools involved. This project required students with basic understanding of both power systems and electromagnetics, which was not easy to find. In addition, each of the students involved in the project required training with the tools used (IntermagNet, COMSOL and MATLAB), creating some delays.

6. Budget Overview

As planned, all expenses from this project correspond to hourly salary for students, as shown below.

Expenses	Description	Balance
\$5,360	Hourly salary for two graduate students and one undergraduate student.	\$4,640

7. Students

The proposed research has been performed at WMU under the direct supervision of the PI and co-PI with several undergraduate and graduate WMU students leading the research activities over

the course of the project. Specifically, the following students have been involved in this project so far:

- Benjamin Exline, Electrical Engineering Undergraduate student, from January to May 2024, Task 1
- Ujala Gamage, Electrical and Computer Engineering PhD student, From May to August 2024, Task 1 and Task 2
- Daniel Nyakundi, Electrical Engineering MS student, from September 2024 to date, Task 2.
- Junior Sterling, Electrical Engineering MS student, Tasks 1, 2 and 3, since January 2025 (ongoing).

8. Current and Pending Products

- A MS thesis is in progress focused on the main topic of this project.
- A technical paper is planned as a result of this project.
- Once sufficient preliminary work is completed by means of the MS thesis in progress, we plan to submit a grant proposal to the DOE Office of Cybersecurity, Energy Security, and Emergency Response (CESER).

9. References

[1] NASA Jet Propulsion Laboratory – California Institute of Technology, “Geomagnetically Induced Currents (GICs)”, April 19, 2017. Available online:

<https://www.jpl.nasa.gov/infographics/geomagnetically-induced-currents-gics>

[2] “GIC Quick Start Guide”, Power World Corporation, March 2012. Available online:

<https://www.powerworld.com/files/GICModeling.pdf>

[3] I. Fadelli, “The effects of solar flares on Earth's magnetosphere, Phys.org, April 2021. Available online: <https://phys.org/news/2021-04-effects-solar-flares-earth-magnetosphere.html>

[4] V. N. Rajput, D. H. Boteler, N. Rana, M. Saiyed, S. Anjana, M. Shah, “Insight into impact of geomagnetically induced currents on power systems: Overview, challenges and mitigation, Electric Power Systems Research, vol. 192, March 2021

[5] J. P. Eastwood, et al., “The Economic Impact of Space Weather: Where Do We Stand?” Risk Analysis, vol. 37, no. 2, pp. 206-218, 2017

[6] A. Oke, P. Gomez, "Synergistic Approach for Computational Analysis of Geomagnetically Induced Currents in Power Grids", North American Power Symposium (NAPS) 2023, Asheville, NC, USA, October 2023

[7] International Real-time Magnetic Observatory Network: <https://intermagnet.github.io/>

[8] A. Kelbert “The Role of Global/Regional Earth Conductivity Models in Natural Geomagnetic Hazard Mitigation,” Surveys in Geophysics, vol. 41, pp. 115–166, 2020

[9] R. Horton, D. Boteler, T. J. Overbye, R. Pirjola and R. C. Dugan, "A Test Case for the Calculation of Geomagnetically Induced Currents," in IEEE Transactions on Power Delivery, vol. 27, no. 4, pp. 2368-2373, Oct. 2012

[10] D. Appell, "May 2024 super geomagnetic storm challenges current space weather prediction models", Science X Network, October 2024

[11] V. M. Jimenez-Mondragon, R. Escarela-Perez, E. Melgoza, M. A. Arjona and J. C. Olivares-Galvan, "Quasi-3-D Finite-Element Modeling of a Power Transformer," IEEE Transactions on Magnetics, vol. 53, no. 6, pp. 1-4, June 2017,

[12] M. Mahamed, S. Seyyedbarzegar, "Design and Thermal Analysis of a 250 MVA HTS Transformer for Substation of Offshore Wind Farms," Physica C: Superconductivity and its applications, vol. 620, 2024