

DOE/EA-1050
May 1996

Environmental Assessment

Test Area North Pool Stabilization Project

RECEIVED
JUN 21 1996
OSTI

DISCLAIMER

This report was prepared as an account of work sponsored by an agency of the United States Government. Neither the United States Government nor any agency thereof, nor any of their employees, makes any warranty, express or implied, or assumes any legal liability or responsibility for the accuracy, completeness, or usefulness of any information, apparatus, product, or process disclosed, or represents that its use would not infringe privately owned rights. Reference herein to any specific commercial product, process, or service by trade name, trademark, manufacturer, or otherwise does not necessarily constitute or imply its endorsement, recommendation, or favoring by the United States Government or any agency thereof. The views and opinions of authors expressed herein do not necessarily state or reflect those of the United States Government or any agency thereof.



Idaho National Engineering Laboratory

U.S. Department of Energy • Idaho Operations Office



MASTER

DISTRIBUTION OF THIS DOCUMENT IS UNLIMITED
DLC

DISCLAIMER

Portions of this document may be illegible in electronic image products. Images are produced from the best available original document.

**U. S. DEPARTMENT OF ENERGY
FINDING OF NO SIGNIFICANT IMPACT FOR THE
TEST AREA NORTH POOL STABILIZATION PROJECT
AT THE IDAHO NATIONAL ENGINEERING LABORATORY**

Agency: U. S. Department of Energy (DOE)

Action: Finding of No Significant Impact (FONSI)

SUMMARY: The DOE-Idaho Operations Office has prepared an environmental assessment (EA) for the proposed Test Area North (TAN) Pool Stabilization Project at the Idaho National Engineering Laboratory (INEL). The purpose of this project is to remove the Three Mile Island (TMI) core debris, Loss-of-Fluid Tests fuels (LOFT) and government-owned commercial spent nuclear fuels (SNF) from the TAN storage pool, provide an environmentally sound method for interim storage, and stabilize the storage pool. This action will be conducted in a manner that ensures protection of human health and the environment.

The *Department of Energy Programmatic Spent Nuclear Fuel Management and Idaho National Engineering Laboratory Environmental Restoration and Waste Management Programs Final Environmental Impact Statement (DOE/EIS-0203-F)*, hereafter referred to as the FEIS, analyzed the cumulative environmental impacts of spent nuclear fuel management on the INEL including the consolidation of SNF at the Idaho Chemical Processing Plant (ICPP) and the proposed TAN Pool Stabilization Project. The Record of Decision (ROD) for this FEIS makes a decision to consolidate spent fuels currently stored at various locations at the INEL at ICPP as funding allows but deferred the decision on the TAN Pool Stabilization Project pending further project definition, funding priorities, or appropriate review under National Environmental Policy Act (NEPA). This EA was prepared to provide the further NEPA review identified in the ROD and address the site specific environmental impacts of the TAN Pool Stabilization Project.

The EA examined the potential environmental impacts of the proposed action and evaluated reasonable alternatives, including the no action alternative in accordance with the Council on Environmental Quality Regulations (40 CFR Parts 1500-1508). The proposed action analyzed in the EA would remove the canisters of TMI core debris and commercial fuels from the TAN Pool and transfer them to the ICPP for interim dry storage in an Interim Storage System (ISS) until an alternate storage location other than at the INEL, or a permanent federal SNF repository is available. The TAN Pool would be drained and placed in an industrially and radiologically safe condition for refurbishment or eventual decommissioning. The EA evaluated environmental impacts associated with (a) constructing an Interim Storage System (ISS) at ICPP; (b) removing the TMI and commercial fuels from the pool and transporting them to ICPP for placement in the ISS, and (c) draining and stabilizing the TAN Pool. Miscellaneous hardware would be removed and decontaminated or disposed of in the INEL Radioactive Waste Management Complex (RWMC). This EA also described the environmental consequences of the no action alternative. Based on the analysis in the EA, the action will not have a significant effect on the human environment within the meaning of NEPA and 40 CFR Sections 1508.18 and 1508.27.

While the EA evaluated the impacts associated with the overall scope of the TAN Pool Stabilization Project, this FONSI is limited to actions that are within the scope of DOE's decision-making authority. The DOE is applying to the Nuclear Regulatory Commission (NRC) for licensing of: a) the transportation of the spent nuclear fuel and debris to ICPP and b) the construction and operation of the ISS. While these actions are outside of the scope of DOE's decision-making authority, they will be evaluated by the NRC as part of their independent NEPA evaluation and decision-making process on these matters.

Selected Action: The selected action consists of the following elements, each of which are described or evaluated in the attached EA on the pages referenced:

- Proceed with the application for NRC licensing of the transportation and Interim Storage System (ISS). This will require development of the design for the ISS and transportation system to further refine information for the evaluation of impacts associated with these systems. The NRC will use this information to conduct their evaluation of the license application and NEPA analysis (pp. 7, 9).
- Continue with design and testing of a system to remove commercial fuels and canisters of TMI core debris from the storage pool, dewatering the canisters, and prepare the canisters and commercial fuels for transport;
- Upon NRC approval of the ISS location and method of transportation, DOE will:

dewater the TMI canisters, remove the canisters from the storage pool, and prepare them for transport (p. 8);

remove the LOFT and commercial fuels from the storage pool, drip-dry the fuels in the TAN Hot Shop, and prepare the fuels for transport (p. 8);

remove hardware from the storage pool, decontaminate reusable hardware, and dispose of the remaining hardware as low-level waste at the RWMC (p. 8);

drain the storage pool, treat the pool water with an ion exchange system or other suitable treatment system, and discharge the treated water in compliance with applicable state and federal regulations (p. 9);

stabilize the pool to place it in an industrially and radiologically safe condition for refurbishment or decommissioning (pp. 9, 17).

Schedule: The NRC licensing action is scheduled to begin in Fiscal Year 1996 and would be conducted in a manner so as to comply with the schedule stipulated in the October 16, 1995 Settlement Agreement between DOE and the State of Idaho. This schedule identifies that the TMI fuel (core debris) will be placed in the interim dry storage facility by June 1, 2001. Also, as stipulated in the Settlement Agreement, DOE has consulted with the State of Idaho concerning the location of the interim dry storage system within the INEL.

SUMMARY OF IMPACTS: The following is a summary of the impacts evaluated in the EA at the referenced pages and presented in relation to the significance criteria described in 40 CFR 1508.27.

1) Beneficial and adverse impacts [40 CFR 1508.27 (b)(1)]:

- The selected action will resolve the issue of potential future vulnerabilities associated with the storage pool (pp.1-5).
- There are no adverse impacts associated with:
 - ▶ Construction activities (p. 25);
 - ▶ Radiation emissions and exposure (pp. 25-29);
 - ▶ Storage pool water treatment and discharge (pp. 27-29);
 - ▶ Generation of radioactive and nonradioactive wastes (pp. 28-29);
 - ▶ Socioeconomic factors (pp. 29).

- 2) **Public health and safety [40 CFR 1508.27 (b)(2)]:**
 - Public exposure to radiation will be below levels known to cause adverse health effects (pp. 27, 33).
 - The highest probability of a cancer fatality in the public resulting from a "worst case" accident scenario is below the average cancer mortality rate (pp. 29-32).
 - Worker exposure during canister handling, dewatering, and transporting is within acceptable limits established by DOE (pp. 26-28).
- 3) **Unique characteristics of the geographical area [40 CFR 1508.27 (b)(3)]:**
 - No unique characteristics of the geographical area will be impacted by the project (p. 29).
- 4) **Degree to which effects on the quality of the human environment are likely to become highly controversial [40 CFR 1508.27 (b)(4)]:**
 - The project will result in no significant adverse effects on the quality of the human environment.
- 5) **Uncertain or unknown risks on the human environment [40 CFR 1508.27 (b)(5)]:**
 - No unique, uncertain, or unknown risks to, or effects on, the human environment will result from the operational or cumulative impacts associated with the project.
- 6) **Precedent for future actions [40 CFR 1508.27 (b)(6)]:**
 - The project does not set a precedent for future actions that may have significant effects.
- 7) **Cumulatively significant impacts [40 CFR 1508.27 (b)(7)]:**
 - There are no significant cumulative impacts associated with the project (p. 33-34). The cumulative impacts of reasonably foreseeable related actions have been evaluated in the FEIS. The interim storage of spent nuclear fuel at INEL is addressed in Volume I of the FEIS and the impacts of the TAN Pool Stabilization Project are addressed in Volume II. The FEIS ROD, issued May 30, 1995, identified the TAN Pool Stabilization Project as one of the projects that would be constructed under the selected alternative for INEL, the Modified Ten Year Plan (Modified Alternative B in the FEIS).

Comments were received on the draft version of this FONSI asserting that an EIS, rather than an EA, should be prepared for the TAN Pool Stabilization Project. As stated above, the FEIS has been prepared that addresses the programmatic management of spent nuclear fuel across DOE as well as the cumulative impacts of spent nuclear fuel management and related actions at the INEL. This EA compliments the FEIS with additional detailed site and project specific description and environmental analysis. (See Appendix A of the EA for DOE-ID's responses to comments.) The Department of Energy is also applying for an NRC license for the ISS and transportation aspects of the project. NEPA analysis for the transportation of the spent nuclear fuel and debris to ICPP and the construction and operation of the ISS will be conducted by the NRC as part of their regulatory review.

- 8) **Effect on cultural or historical resources [40 CFR 1508.27 (b)(8)]:**
 - No cultural resources are anticipated to be impacted (pp. 25, 29). The TAN Storage Pool and Hot Shop are potentially eligible for listing on the National Register of Historic Places, however, this action will not modify these structures (p. 25).
- 9) **Effect on threatened or endangered species or critical habitat [40 CFR 1508.27 (b)(9)]:**
 - No threatened or endangered species or critical habitat will be affected by the action (p. 29).
- 10) **Violation of Federal, State, or Local law [40 CFR 1508.27 (b)(10)]:**
 - The project will not violate any federal, state, or local law.

DETERMINATION: Based on analysis presented in the attached EA, I have determined that this project does not constitute a major Federal action significantly affecting the quality of the human environment. Therefore, preparation of an environmental impact statement is not required and I am issuing this FONSI.

INFORMATION: Copies of the EA and FIES are available from: Brad Bugger, Office of Communications, MS-1214, Idaho Operations Office, U. S. Department of Energy, 850 Energy Drive, Idaho Falls, Idaho, 83403-3189, or by calling (208) 526-0833 or the toll-free INEL citizen inquiry line (800)708-2680.

For further information on the NEPA process contact: Roger Twitchell, NEPA Compliance Officer, MS-1216, U. S. Department of Energy, 850 Energy Drive, Idaho Falls, Idaho, 83403-3189, (208) 526-0776.

Issued at Idaho Falls, Idaho on this 6th day of May, 1996.

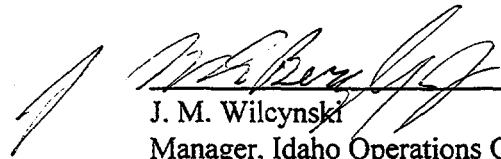

J. M. Wilcynski
Manager, Idaho Operations Office

DOE/EA-1050

Environmental Assessment
Test Area North Pool Stabilization Project

Published May 1996

U.S. Department of Energy
DOE Idaho Operations Office
Idaho Falls, Idaho

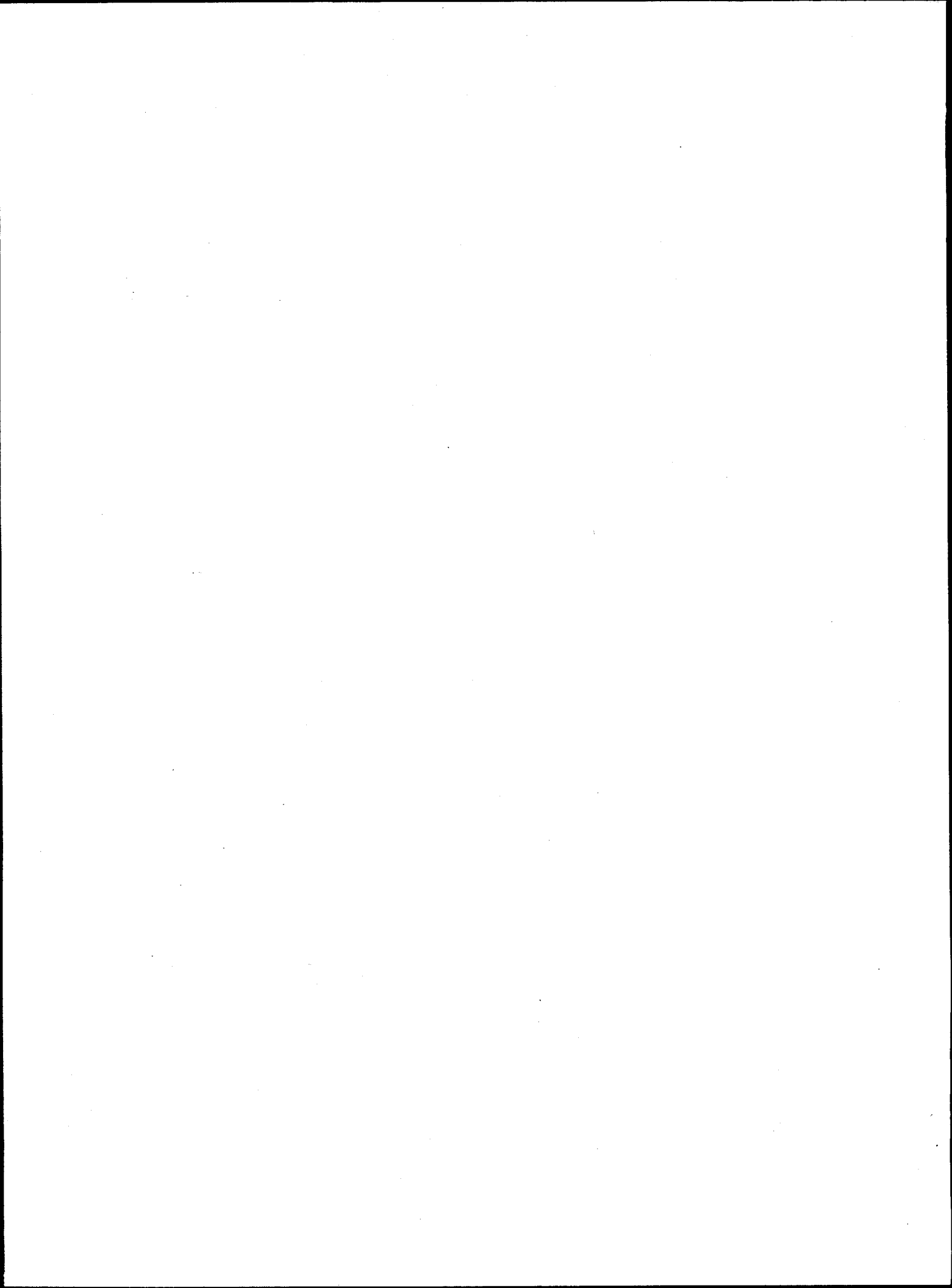

CONTENTS

CONTENTS	iii
FIGURES	iv
TABLES	iv
ACRONYMS AND ABBREVIATIONS	v
GLOSSARY	vii
Unit Prefixes	x
1. INTRODUCTION	1
1.1 Need for Action	3
1.2 Background	3
1.3 Related Actions	7
2. DESCRIPTION OF THE PROPOSED ACTION AND ALTERNATIVES	8
2.1 Proposed Action	8
2.1.1 Removal of TMI Debris, Commercial Fuel, and Hardware from the Pool	8
2.1.2 Transportation of TMI Canisters, Hardware, and Commercial Fuel	8
2.1.3 Interim Storage System (ISS)	9
2.1.4 TAN Pool Draining and Decontamination Operations	9
2.2 Alternatives to the Proposed Action	17
2.2.1 No Action	17
2.2.2 Alternatives Considered and Dismissed	17
3. AFFECTED ENVIRONMENT	22
4. ENVIRONMENTAL IMPACTS	25
4.1 Impacts Associated with the Proposed Action	25
4.1.1 Construction Impacts	25
4.1.2 Operational Impacts	26
4.1.3 Potential Impacts from Accidents	29
4.1.4 Cumulative Impacts	33
4.2 Impacts Associated with the No Action Alternative	34
5. PERMIT AND REGULATORY REQUIREMENTS	36
6. AGENCIES AND PERSONS CONSULTED	38
7. REFERENCES	39

Appendix A—Responses to Comments	A-1
Appendix B—Siting Analysis Summary for the TMI Debris and Commercial Fuel Interim Storage System	B-1

FIGURES

Figure 1. Location of facilities within the INEL.	2
Figure 2. Diagram of the TAN Hot Shop and TAN Pool Area.	4
Figure 3. Diagrams of the three types of TMI core debris canisters.	6
Figure 4. Proposed ISS location at ICPP.	10
Figure 5. Illustration of Typical Life-of -Plant NUHOMS-® ISFSI (for information only).	11
Figure 6. NUHOMS ® System Components Structures, and Transfer Equipment Elevation View.	12
Figure 7. NUHOMS ® Dry Shielded Canister Assembly Components.	13
Figure 8. NUHOMS Trailer-Mounted MP-187 Transport Cask.	14
Figure 9. Foster Wheeler Single MVDS Vault Module.	15
Figure 10. Sierra Nuclear Ventilated Storage Cask (VSC-24).	16
Figure 11. Location of TSF-07 disposal pond.	18
Figure 12. Eastern Snake River Plain and the Northern Part of the Snake River Basin (USGS1992). ...	20

TABLES

1. Resource and FEIS (DOE 1995) Cross Reference	22
2. Potential Radionuclide Inventory and Releases	26
3. EDE to MEI Due to Potential Airborne Releases from Existing Storage and the Proposed Action (Staley 1996)	27
4. Upper-bound estimates of airborne radionuclides (curies/accident) resulting from postulated accidents of the proposed action during Hot Shop operations.	31
5. Summary of radiological effects from releases due to accident scenarios	32
6. Radiological Air Emission Baseline and Ten-year Dose (DOE 1995).	34

ACRONYMS AND ABBREVIATIONS

ALARA	as low as reasonably achievable
BAT	best available technology
CAM	constant air monitor
CFR	Code of Federal Regulations
Ci	Curies
Co	cobalt
Cs	cesium
DCG	derived concentration guide
DOE	U.S. Department of Energy
DOE-ID	U.S. Department of Energy-Idaho Operations Office
DOT	U.S. Department of Transportation
EA	Environmental Assessment
EBR-1	Experimental Breeder Reactor-1
EDE	effective dose equivalent
EPA	Environmental Protection Agency
FEIS	Department of Energy Programmatic Spent Nuclear Fuel Management and Idaho National Engineering Laboratory Environmental Restoration and Waste Management Programs Final Environmental Impact Statement
FONSI	Finding of No Significant Impact
FR	Federal Register
<i>g</i>	acceleration due to gravity at sea level
H-3	tritium
HEPA	high efficiency particulate air
HLLW	high-level liquid waste
I	iodine
ICPP	Idaho Chemical Processing Plant
IDAPA	Idaho Administrative Procedures Act
IFSF	Irradiated Fuel Storage Facility
INEL	Idaho National Engineering Laboratory
ISFSI	independent spent fuel storage installation (10 CFR 72)
ISS	Interim Storage System
Kr	krypton

LET&D Liquid Effluent Treatment and Disposal
 LLW low-level waste
 LITCO Lockheed Idaho Technologies Company
 LOFT loss-of-fluid test

MCL maximum contaminant level
 MEI maximally exposed individual
 MPF maximum probable flood
 mrem millirem

NEPA National Environmental Policy Act
 NESHAP National Emissions Standards for Hazardous Air Pollutants
 NHPA National Historic Preservation Act
 NPDES National Pollutant Discharge Elimination System
 NRC U.S. Nuclear Regulatory Commission
 NSB nearest site boundary

PEW Process Equipment Waste
 PSP Pool Stabilization Project
 PTC Permit to Construct

RAM remote air monitor
 RCRA Resource Conservation and Recovery Act
 RSAC Radiological Safety Analysis Computer Program
 ROD Record of Decision
 RWMC Radioactive Waste Management Complex

SHPO State Historic Preservation Officer
 SNF spent nuclear fuel

TAN Test Area North
 TSF Technical Support Facility
 TMI Three Mile Island

USGS United States Geological Survey

W watts
 WINCO Westinghouse Idaho Nuclear Company

GLOSSARY

As low as reasonably achievable (ALARA): An approach to radiation protection to control or manage exposures (both individual and collective to the work force and the general public) and releases of radioactive material to the environment as low as social, technical, economic, practical, and public policy considerations permit.

Beyond design basis accident: An accident of the same type as a distinct design basis accident (fire, earthquake, etc) but defined by parameters that exceed in severity the parameters defined for the design basis accident.

Coffin: The box, case, or structure in which a fuel assembly is placed for safe storage. The outer dimensions are sized to ensure criticality safety when several coffins are stored together.

Criticality: An expression of the ability of a fission reaction to sustain itself based on the change in the number of neutrons engaging in the fission reaction, with each such neutron being responsible for a fission event. Since not all neutrons result in a fission event (some escape or are absorbed without resulting in a fission event), a self-sustained reaction requires enough neutrons to be produced in the fission events to sustain the reaction rate after accounting for losses. Such a balanced, equilibrium situation is referred to as a *critical* reaction, which is self-sustaining (does not need an outside neutron source) and stable (the fission rate is neither increasing nor dropping off).

Curie (Ci): A unit of radioactivity equal to 37 billion disintegrations per second; also a quantity of any radionuclide or mixture of nuclides having one Ci of activity.

Decontaminate (Decontamination): The removal or the fixing in place of radioactively contaminated particles.

Derived concentration guide (DCG): The concentration of a radionuclide in air or water that, under conditions of continuous exposure for 1 year by one exposure mode (i.e., ingestion of water, submersion in air, or inhalation), would result in an effective dose equivalent of 100 mrem (0.1 rem).

Design basis accident: Accidents that are postulated for the purpose of establishing functional requirements for safety of significant structures, systems, components, and equipment.

Dewatered Canister: A dewatered canister is one in which a majority of the free standing water has been removed. Currently, the TMI canisters are fully flooded in their storage condition in the TAN Pool. Just prior to shipping the canisters to the ICPP for interim storage, they will be dewatered. After dewatering, there will still be some free water intermingled in the debris and in the lower head (below the lower end of the drain line) of all canister types. In addition, the fuel type canisters have a LICON (light weight cement) liner that contains water. The water in this liner consists of pore water cast into the cement, water that flooded into the liner chamber after the canisters were immersed, and an unknown, but substantial quantity of water of hydration. By definition, water of hydration is water in a hydrated condition. Hydrates are solids that contain water molecules as part of their crystalline structure. The water molecules are bonded by electrostatic forces between polar water molecules and the positive or negative ions of the compound. These forces are not as strong as covalent or ionic chemical bonds. Water of hydration may be removed from the LICON liners by heating to approximately 700 to 1,100°F.

Effective dose equivalent (EDE): The sum of the products of absorbed dose and appropriate factors to account for differences in biological effectiveness caused by the quality of radiation and its distribution in the body of a reference man. The unit of the effective dose equivalent is the roentgen equivalent man (rem).

High-efficiency particulate air (HEPA) filter: A disposable filter having a minimum removal efficiency of 99.97% for 0.3 micron or larger particles.

Ion: An electrically charged atom or group of atoms. The electrical charge results when a neutral atom or group of atoms loses or gains one or more electrons. The loss of electrons results in positively charged ions (cations), the gain of electrons results in negatively charged ions (anions)

Isotope: One of two or more atoms with the same number of protons, but different numbers of neutrons, in their nuclei. Thus, carbon-12, carbon-13, and carbon-14 are isotopes of the element, carbon, the numbers denoting the approximate atomic weights. Isotopes have very nearly the same chemical properties, but often different physical properties (for example, carbon-12 and -13 are stable, carbon-14 is radioactive).

Ion exchange: A reversible process in which a solution passes over a medium that removes the soluble ions by exchanging them with labile (unstable) ions from the medium.

Maximum contaminant levels (MCLs): Environmental Protection Agency standards for contaminants in public drinking water that may have an adverse effect on people's health.

Maximally exposed individual (MEI): A hypothetical individual defined to allow dose or dosage comparison with numerical criteria for the public. This individual is located at the point on the INEL site boundary nearest to the facility in question.

Radiation absorbed dose (rad): The basic unit of absorbed dose equal to absorption of 0.01 joule per kilogram of absorbing material.

Radiolysis: Decomposition of water to form hydrogen and oxygen when subjected to a radiation environment.

Radioisotope: An unstable isotope of an element that decays or disintegrates spontaneously, emitting radiation. Approximately 5,000 natural and artificial radioisotopes have been identified.

Radionuclide: See radioisotope

Roentgen equivalent man (rem): The dosage of ionizing radiation that will cause the same biological effect as one roentgen of x-ray or gamma-ray exposure.

- **millirem** is a unit equal to 1/1000th of a rem.
- **person-rem** is a unit of collective radiological dose or the collective total dose to a population and is calculated by summing the individual doses to each member of the given population. For instance, if a population of 100 people receive 0.1 rem, then the collective dose would be 10 person-rem (100 persons x 0.1 rem).

Sizing: The process of reducing the size of various types of solid wastes by compaction, melting, or cutting.

Stabilize (Stabilization): To place the pool in a radiologically and environmentally safe, nonoperable condition, suitable for refurbishment or eventual decommission. The TAN Pool is considered to be stabilized once all of the fuel-bearing and other radioactively contaminated materials are removed from the pool, the pool water is removed, and the remaining pool surfaces are decontaminated (see Glossary) to a level reflective of the remainder of the Hot Shop.

Unit Prefixes

<u>Prefix</u>	<u>Power</u>	<u>Value</u>	<u>Symbol</u>
mega	10^6	1,000,000	M
kilo	10^3	1,000	k
centi	10^{-2}	0.01	c
milli	10^{-3}	0.001	m
micro	10^{-6}	0.000001	μ
nano	10^{-9}	0.000000001	n
pico	10^{-12}	0.000000000001	p
femto	10^{-15}	0.000000000000001	f

Conversion Table

<u>English</u>	<u>Metric</u>
1 foot	0.3048 meters
1 cubic foot	0.02832 cubic meters
1 gallon	3.785 liters
1 mile (5280 feet)	1609 meters

1. INTRODUCTION

The Test Area North (TAN) Pool is located within the fenced TAN facility boundaries on the Idaho National Engineering Laboratory (INEL) (Figure 1). The TAN pool stores 344 canisters of core debris from the March, 1979, Three Mile Island (TMI) Unit 2 reactor accident; fuel assemblies from Loss-of-Fluid Tests (LOFT); and Government-owned commercial fuel rods and assemblies. The LOFT and government owned commercial fuel rods and assemblies are hereafter referred to collectively as "commercial fuels" except where distinction between the two is important to the analysis.

DOE proposes to remove the canisters of TMI core debris and commercial fuels from the TAN Pool and transfer them to the Idaho Chemical Processing Plant (ICPP) for interim dry storage until an alternate storage location other than at the INEL, or a permanent federal spent nuclear fuel (SNF) repository is available. The TAN Pool would be drained and placed in an industrially and radiologically safe condition for refurbishment or eventual decommissioning.

This environmental assessment (EA) identifies and evaluates environmental impacts associated with (a) constructing an Interim Storage System (ISS) at ICPP; (b) removing the TMI and commercial fuels from the pool and transporting them to ICPP for placement in an ISS, and (c) draining and stabilizing the TAN Pool. Miscellaneous hardware would be removed and decontaminated or disposed of in the INEL Radioactive Waste Management Complex (RWMC). This EA also describes the environmental consequences of the no action alternative.

This EA "tiers" from a Final Environmental Impact Statement (FEIS) that analyzed the environmental impacts of various activities at the INEL, including this TAN Pool Stabilization project. See *Department of Energy Programmatic Spent Nuclear Fuel Management and Idaho National Engineering Laboratory Environmental Restoration and Waste Management Programs Final Environmental Impact Statement* (DOE, 1995). Specific areas of the FEIS that are pertinent to this EA include:

- Vol. 2, Part A, Table 2.2-1 *Corrective Actions for Addressing Spent Fuel Vulnerabilities - Test Area North*
- Vol. 2, Part A, Table 3.1-2 *Spent Nuclear Fuel - Related Projects at the INEL* (Tan Pool Stabilization Project considered in alternatives A, B, and D discussion throughout Section 3.1)
- Volume 2, Section 3.3 *Comparison of Impacts*
- Volume 2, Section 3.4 *Preferred Alternative*
- Volume 2, Section C-2.1 *Test Area North Pool Fuel Transfer*.

In addition to those environmental impacts analyzed in a general manner in the FEIS, this EA is written to describe the specific impacts of the TAN Pool Stabilization Project. The potential impacts of the proposed action and the no action alternative are evaluated in relation to the affected environment, operational and accidental releases of radiological contaminants, applicable environmental regulations, and long term DOE goals. Alternatives considered and dismissed include (a) refurbish the TAN Pool, (b) construct new wet storage, (c) store the TMI core debris canisters and LOFT and commercial fuels in existing ICPP storage

The Idaho National Engineering Laboratory

- ARA = Auxiliary Reactor Area
- CFA = Central Facilities Area
- CTF = Containment Test Facility
- EBR 1 = Experimental Breeder Reactor 1
(Historical Monument)
- ICPP = Idaho Chemical Processing Plant
- IET = Initial Engineering Test
- NRF = Naval Reactors Facility
- PBF = Power Burst Facility
- RWMC = Radioactive Waste Management Complex
- TAN = Test Area North
- TRA = Test Reactor Area
- TSF = Technical Support Facility
- WERF = Waste Experimental Reduction Facility
- WRRTF = Water Reactor Research Test Facility

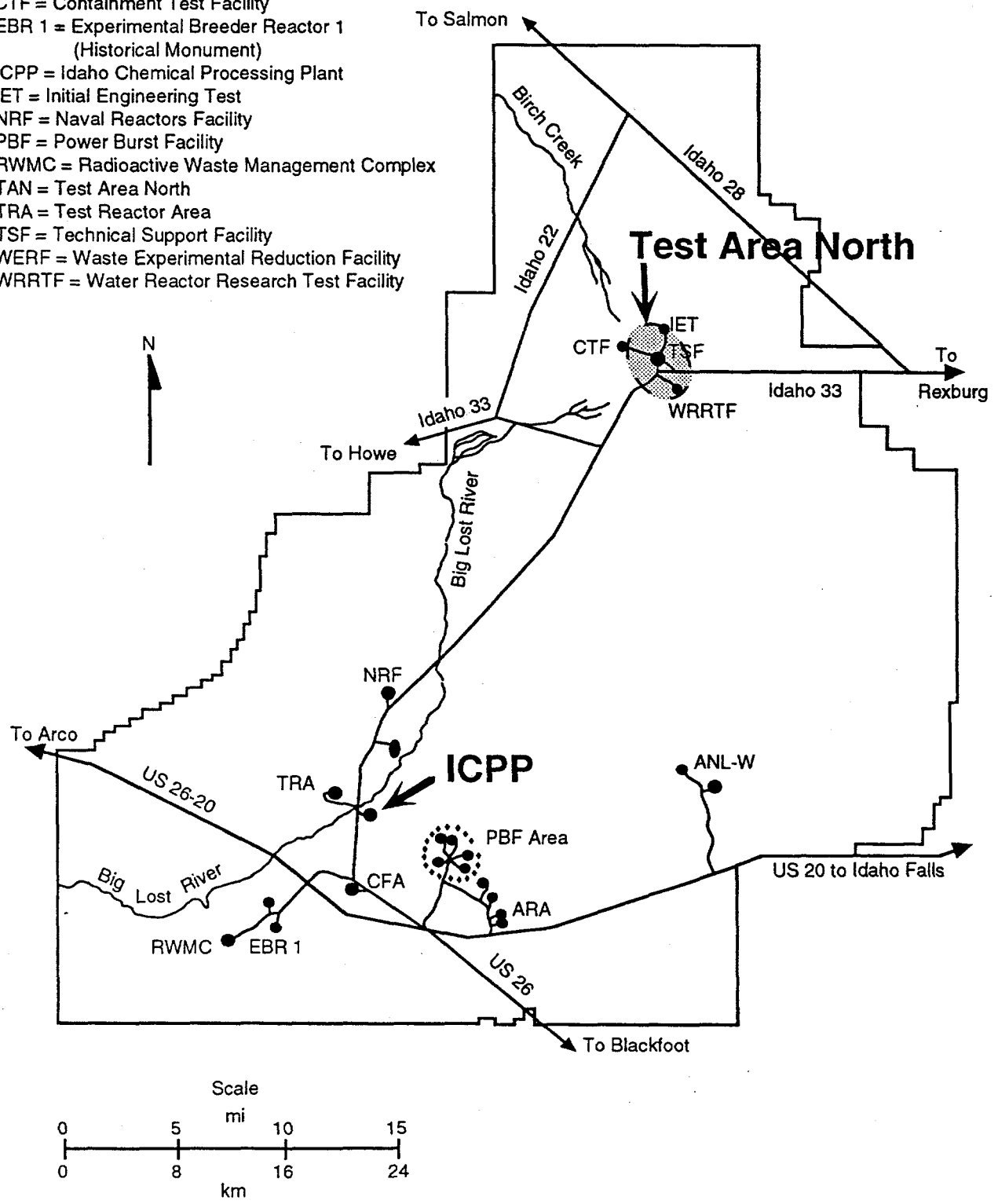

Figure 1. Location of facilities within the INEL.

systems, (d) dry the TMI debris, (e) construct an ISS at a point removed from above the Snake River Plain Aquifer, and (f) construct an ISS at TAN. These alternatives are discussed in Section 2.2.

This EA was released for a thirty day public review on February 20, 1995. Comments received from the public and State of Idaho are addressed in Appendix A. The EA (revised in response to public comment) and the draft FONSI were released for a thirty day public review and comment period from May 10, 1995 to June 9, 1995. Additional public comments were received which have been addressed in this EA.

1.1 Need for Action

- DOE has identified, and proposes to eliminate vulnerabilities associated with SNF storage facilities [*Spent Fuel Working Group Report on Inventory and Storage of the Department's Spent Nuclear Fuel and Other Reactor Nuclear Material and Their Environmental, Safety, and Health Vulnerabilities* (DOE 1993a)]. Vulnerabilities that were originally identified for TAN are storage of SNF in an unlined pool, wet storage of commercial SNF in aluminum coffins, and seismic inadequacy of the pool.^a
- In May of 1995, the State of Idaho asked the District Court to continue the prior injunction against SNF transportation by the Department of Energy, claiming that the FEIS was defective. This litigation was settled between DOE, the Department of the Navy and the State of Idaho. On October 17, 1995, the Federal District Court entered a Court Order that incorporated, as requirements, the terms and conditions of the parties' Settlement Agreement (DOE 1995b). Paragraph E7 of the Settlement Agreement states:

"DOE shall complete construction of the Three Mile Island dry storage facility by December 31, 1998. DOE shall commence moving fuel into the facility by March 31, 1999, and shall complete moving fuel into the facility by June 1, 2001."

- The TAN Pool does not meet SNF storage requirements delineated in U.S. Department of Energy (DOE) Order 420.1 "Facility Safety" (DOE 1995c). Principal deficiencies of the TAN Pool include lack of redundant containment of pool water (i.e., stainless steel pool liner), no provisions for detecting subsurface leaks from the pool, and inadequate control of the air space over the pool.

1.2 Background

The TAN-607 facility, which includes the TAN Pool and Hot Shop (Figure 2), was constructed in 1954. The TAN Pool was designed to store radioactive materials and is presently loaded to nearly 100% of useable capacity with the TMI core debris canisters, commercial fuels, and hardware (DOE 1993a). In August of 1993, the Secretary of Energy commissioned a comprehensive baseline of the environmental, safety, and health vulnerabilities associated with the storage of SNF in the DOE complex. A multidisciplinary working group comprised of DOE employees and contractors evaluated the inventory and condition of DOE's reactor-irradiated nuclear material, which includes SNF and reactor-irradiated target material. The working group

a. Subsequent studies have determined that a design basis seismic event will not result in cracking or leaking of the TAN Pool as discussed in Section 4.2 (Lacey 1994).

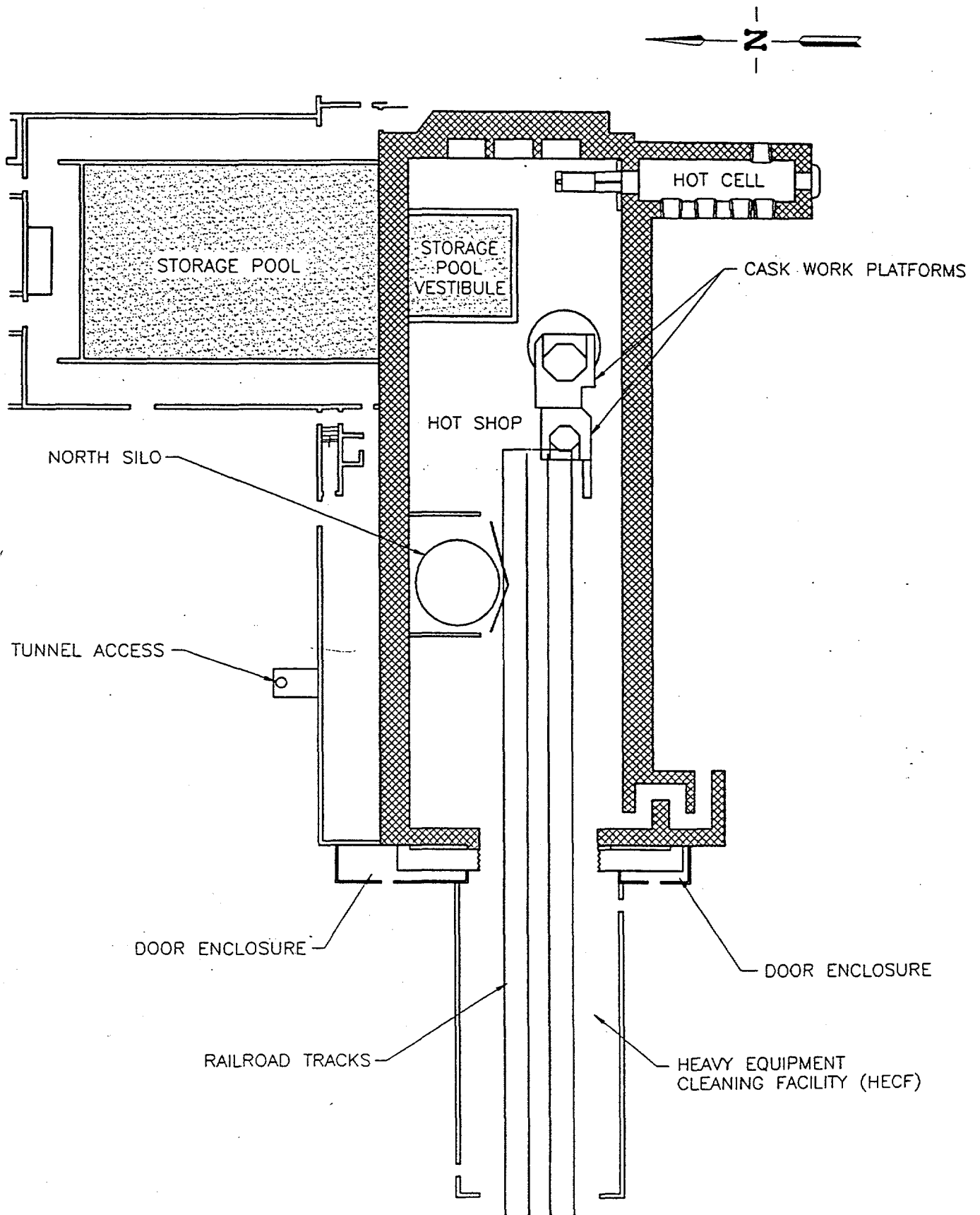

Figure 2. Diagram of the TAN Hot Shop and TAN Pool Area.

also evaluated the condition of facilities that store SNF and identified the vulnerabilities and problems associated with these facilities. Vulnerabilities identified at TAN include inadequate corrosion monitoring, lack of leak detection and leak trending of the pool water inventory and a potential deficiency in the seismic design of the basin (DOE 1993a). DOE issued a Phase I Plan of Action to address SNF storage vulnerabilities in February 1994 (DOE 1994a), a Phase II Plan of Action in April 1994 (DOE 1994b), and a Phase III Plan of Action in October 1994 (DOE 1994c). The TAN Pool Stabilization Project addresses vulnerabilities identified in these plans.

The TAN Hot Shop is a large shielded high bay with overhead cranes, a large overhead manipulator, auxiliary wall mounted manipulators, and other equipment for remotely handling radioactive material. The Hot Shop is designed for the examination, testing, and monitoring of SNF, storage casks, and radioactive materials. The TAN Pool consists of the pool and a vestibule, an extension of the TAN Pool. A submerged passageway with an underwater rail system and transfer cart connects the vestibule to the main TAN Pool. The top of the passageway is 5 ft underwater to protect the main pool area from potential radiation sources in the Hot Shop and to isolate the air exchange between the Hot Shop and TAN Pool. The Hot Shop also contains a silo, which is a shielded enclosure used for temporary storage of SNF assemblies and other radioactive materials.

The canisters containing the TMI core debris are stored in a fully flooded and vented condition in the TAN Pool. During defueling operations at the TMI-2 plant, the debris was placed in three types of cylindrical stainless-steel canisters: fuel, knockout, and filter (Figure 3). The fuel canisters are receptacles for large pieces of core debris, the knockout canisters were designed to contain smaller debris, and the filter canisters contain stainless-steel filters and fines that were collected in the filters during defueling operations. Neutron absorbing materials (boron carbide poison in the form of plates or rods) were designed into each type of canister to prevent criticality events. The canisters, placed in the TAN Pool between 1986 and 1990, are currently stored in a six-pack configuration in stainless-steel storage modules lined with poison plates.

In a wet storage condition, the TMI canisters must vent to release radiolytic generated hydrogen and oxygen. Venting is accomplished through a vent orifice located in the top of each canister. Orifices were sealed using protective caps for canister shipment from TMI in Pennsylvania to the INEL. The canisters were received at TAN and placed in the TAN Pool, the protective caps removed, and the canisters flooded with demineralized water. To allow gases generated within the canisters to escape, the vent port on each canister was connected to a water filled vent tube that extends upwards and out of the pool water surface.

The LOFT fuel assemblies originated at the LOFT facility at TAN. LOFT was a scaled-down version of a commercial pressurized water reactor where tests were conducted from 1976–1985. When the LOFT tests were completed, the fuel assemblies were taken to the Hot Shop and placed in modified TMI six-pack containers for underwater storage in the TAN pool. There are 13 complete LOFT fuel assemblies and 13 small containers (approx. 10" x 10" x 12") of LOFT fuel remnants.

The commercial fuels, which were brought to the INEL for research and development purposes, consist of fuel rods and assemblies from commercial pressurized water reactors. The fuels consist of a 10 x 10 array of aluminum storage racks containing 35 individual fuel rods, seven aluminum fuel storage coffins

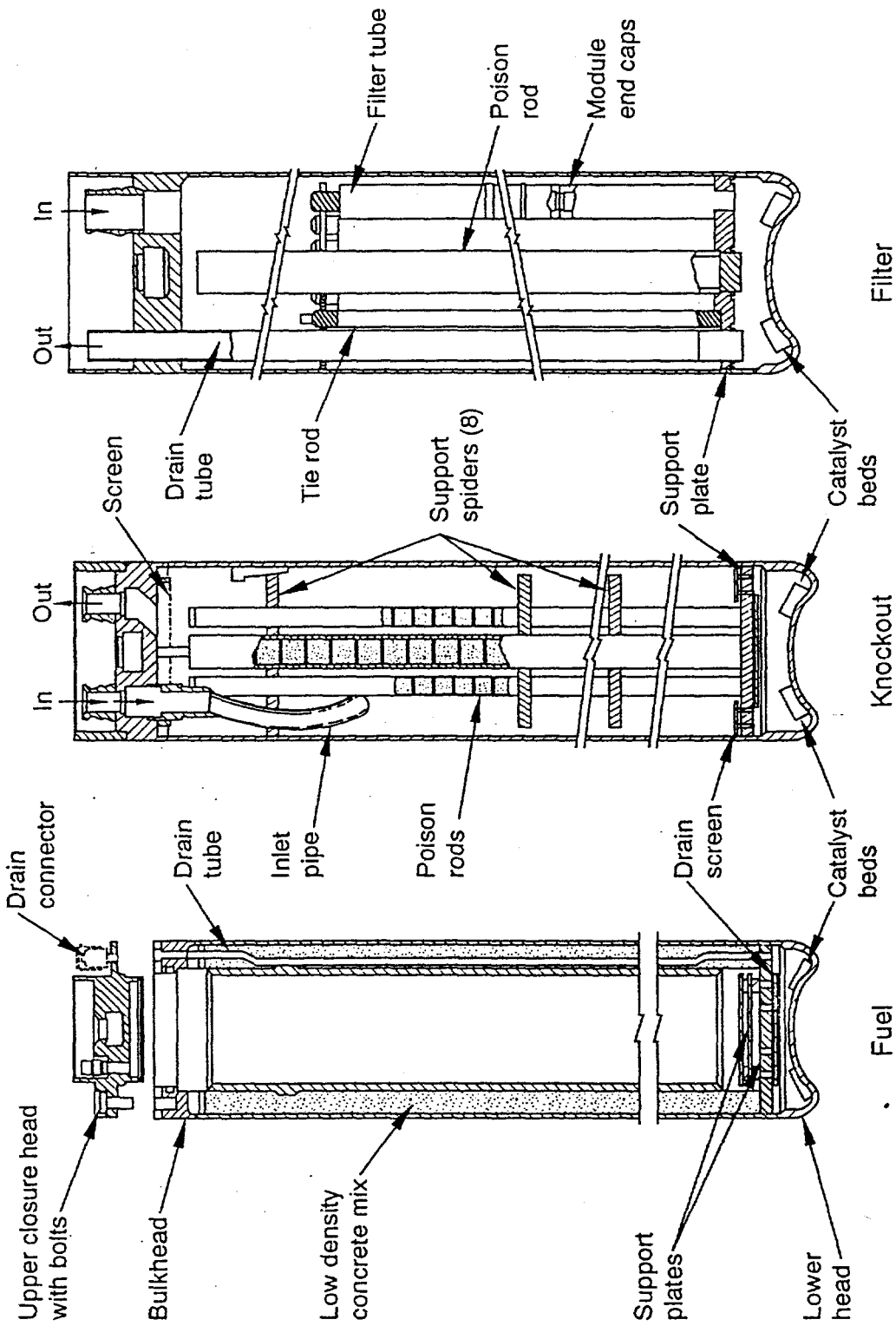

Figure 3. Diagrams of the three types of TMI core debris containers.

(see Glossary) holding a total of six fuel rod assemblies and a loose fuel rod basket. Miscellaneous hardware that would be removed from the pool after removing the TMI canisters and commercial fuels is identified in Section 2.1.1.

The damaged TMI core material contained in the canisters does not consist of intact fuel assemblies or fuel rods typical of normal commercial fuels. The core material is an agglomerate of the various items that existed within the reactor vessel after the accident. Because of this, the TMI core debris differs from normal commercial SNF and had to be placed in canisters in order to be shipped from the TMI reactor to Idaho for storage. In addition, due to the characteristics of the fuel, it must be stored in a vented configuration or in a storage system designed to accommodate the generation of combustible gases. The accident occurred early in the fuel cycle so burn-up was low, resulting in low decay heat loads in the canisters when compared to decay heat loads of normal SNF (approximately 7,000 W for the TMI core debris versus approximately 2,800,000 W for a comparable reactor core operated through the full-fuel cycle) and relatively low inventories of fission products. The high temperatures and associated core melting during the accident caused massive destruction of the core (fuel cladding, fuel pellets, control rods, and support structures) resulting in the release of a majority of the volatile fission product inventory (Akers et al. 1988). Only extremely high temperatures (greater than 2,912°F) or disruption (such as dissolution) of the fuel would result in release of the remaining volatiles (gaseous fission products). The damaged condition of the fuel, gas generation potential, low heat load, and relatively low volatile fission product inventory differentiate the debris from normal SNF. The commercial fuels also have low decay heat loads; however, because volatile fission products are contained in the fuel rod cladding, vented dry storage is not required.

1.3 Related Actions

On December 7, 1995, the Department of the Navy published an announcement in the Federal Register that they were assuming lead responsibility for an EIS evaluating container systems for the management of Navy SNF. This EIS (previously titled Environmental Impact Statement for a Multi-Purpose Canister System for Management of Civilian and Naval Spent Nuclear Fuel) was being prepared by DOE with the Navy participating as a cooperating agency. DOE is halting its proposal to fabricate and deploy a multi-purpose canister based system and the Office of Civilian Radioactive Waste Management has ceased preparation of the multi-purpose canister EIS. DOE is now a cooperating agency in the preparation the naval container system EIS. The announcement in the Federal Register indicated that the EIS will consider 6 container system alternatives for the management of Navy SNF. The alternatives addressed in the Navy EIS and this EA both consider the dry storage of SNF on the INEL. Therefore the actions addressed by these two NEPA documents are related but not connected or dependent on one another.

DOE is evaluating the benefits of applying for an NRC license for the ISS. If DOE applies for a license, the NRC, in accordance with 10 CFR 51.10 (b), has the right to prepare an independent NEPA evaluation and make a final decision on any matter within the NRC's regulatory authority.

2. DESCRIPTION OF THE PROPOSED ACTION AND ALTERNATIVES

2.1 Proposed Action

The proposed action is to remove the TMI core debris, commercial fuel, and hardware from the TAN Storage Pool. Upon removal from the pool, the fuel and debris would be transported to ICPP for temporary storage in an ISS that would be constructed. Hardware that could be reused would be decontaminated (see Glossary) and the remaining hardware would be removed and disposed of at the RWMC as low-level radioactive waste (LLW). The pool water would be treated and disposed of by one of several options discussed in Section 2.1.4. Following removal of the water, the empty pool would be decontaminated and the pool would be stabilized (see Glossary). The proposed action would be completed within approximately 10 years. Any future proposals for the TAN Pool or the Hot Shop would undergo subsequent NEPA review.

2.1.1 Removal of TMI Debris, Commercial Fuel, and Hardware from the Pool

While submerged, the TMI canisters would be dewatered (see Glossary). To dewater, the canisters would be purged with a gas (such as air, nitrogen or argon) to displace the majority of free water. Once the canisters have been dewatered, they would be removed from the pool and prepared for transport in the Hot Shop. Any associated air emissions from dewatering would be routed through a HEPA filter that would be installed as part of the dewatering system. The filtered air would be discharged to the Hot Shop and vented through the Hot Shop HEPA system to the TAN-734 stack.

The commercial fuels would be removed from the Storage Pool, washed to remove loose surface contamination, and suspended in the Hot Shop to dry. After drip-drying, the LOFT fuel assemblies would be transferred to the TAN Hot Cell located adjacent to the Hot Shop (Figure 2), and the unfueled upper core support structures would be removed so the storage system could accommodate the fuel. The commercial fuels may be staged in the shielded silo within the Hot Shop or in an existing dry storage cask located on the existing pad at TAN prior to transport.

The hardware to be removed from the Pool includes the TMI six-pack storage containers and poison plates, the LOFT six-pack containers, fuel storage coffins, the 10 × 10 storage rack array, and the LOFT upper core support structures. Equipment with potential value for reuse would be decontaminated and the remaining hardware would be transported to RWMC for disposal as LLW.

2.1.2 Transportation of TMI Canisters, Hardware, and Commercial Fuel

After canister dewatering and commercial fuel drip-drying, the respective fuels would be loaded into DOT approved casks for shipment to ICPP. Transportation of the TMI canisters and commercial fuel from TAN to ICPP would require approximately 50 shipments. The distance from TAN to ICPP is approximately 25 miles which includes 5 miles of public road, Idaho Highway 33. Hardware to be disposed of at RWMC as LLW (see Section 4.1.2.3.2) would be placed in boxes and transported approximately 31 miles to RWMC.

2.1.3 Interim Storage System (ISS)

The ISS would be designed to (a) receive the transport cask, (b) transfer the debris and commercial fuels from the transport cask into storage, (c) store the canisters and commercial fuels, (d) allow inspection and monitoring of key safety parameters during storage, and (e) provide for retrievability of the canisters and commercial fuels to allow ready retrieval of SNF for further processing or disposal (10 CFR 72.122). Retrieval capabilities would be to a vacant ISS storage position and to a transport cask.

The ISS would be designed to meet nationally-accepted or national consensus standards of construction, testing, and operation, and be NRC licensable under 10 CFR 72 as an Independent Spent Fuel Storage Installation (ISFSI). This approach would use existing technology available in the commercial SNF storage industry. As such, the ISS would be a dry, SNF storage system which is based on an existing NRC topical license adapted to the unique features of the TMI debris (disrupted fuel in existing storage canisters) and commercial fuel.

The ISS would be sized to accommodate the TMI canisters and commercial fuel. It would be located at ICPP near CPP-666 (Figure 4) in an area that would accommodate cask transport access. This system would require approximately one acre. This ISS would incorporate shielding and design features for safe operation. It would be designed to accommodate combustible gas, specifically hydrogen and oxygen generated by radiolysis (see Glossary). Any gases generated in the canisters would pass through a HEPA filter prior to release to the atmosphere. Constant air monitors (CAMs), remote air monitors (RAMs), and passive air monitoring systems would be used, if required by the safety analysis.

There are several existing commercial NRC licensed ISFSI designs that could be tailored to accommodate the TMI core debris and commercial fuel. These designs include vertical (cylindrical) casks; horizontal, dual purpose transport and storage systems comprised of a storage canister inside a storage module; and vault-type storage systems. An ISFSI may be constructed of metal or concrete. Examples of existing commercial ISFSI designs that could be adapted to these fuels are: horizontal system (Figures 5, 6, 7, and 8); vault type system (Figure 9); and a vertical cask (Figure 10).

2.1.4 TAN Pool Draining and Decontamination Operations

The TAN Pool (including the vestibule) would be drained, then decontaminated and stabilized. The pool water would be sampled and a treatment and disposal option would be selected based on sample analysis and effectiveness in achieving compliance with regulatory requirements (see Section 5.0 for Permit and Regulatory Requirements). Water treatment and disposal options include:

- a) Reducing the volume of water through an evaporative process at TAN and transporting the residues to ICPP for treatment through the existing Process Equipment Waste (PEW) evaporator or the Liquid Effluent Treatment and Disposal (LET&D) facility. Transporting the residues would require an estimated five transport vehicle round trips from TAN to ICPP and would be conducted in accordance with DOT requirements. The PEW condensate would be treated at the LET&D to remove radionuclides and the treated effluent would be discharged to the atmosphere through the main LET&D stack. The concentrates would be sent to the High Level Liquid Waste (HLLW) Tank Farm.

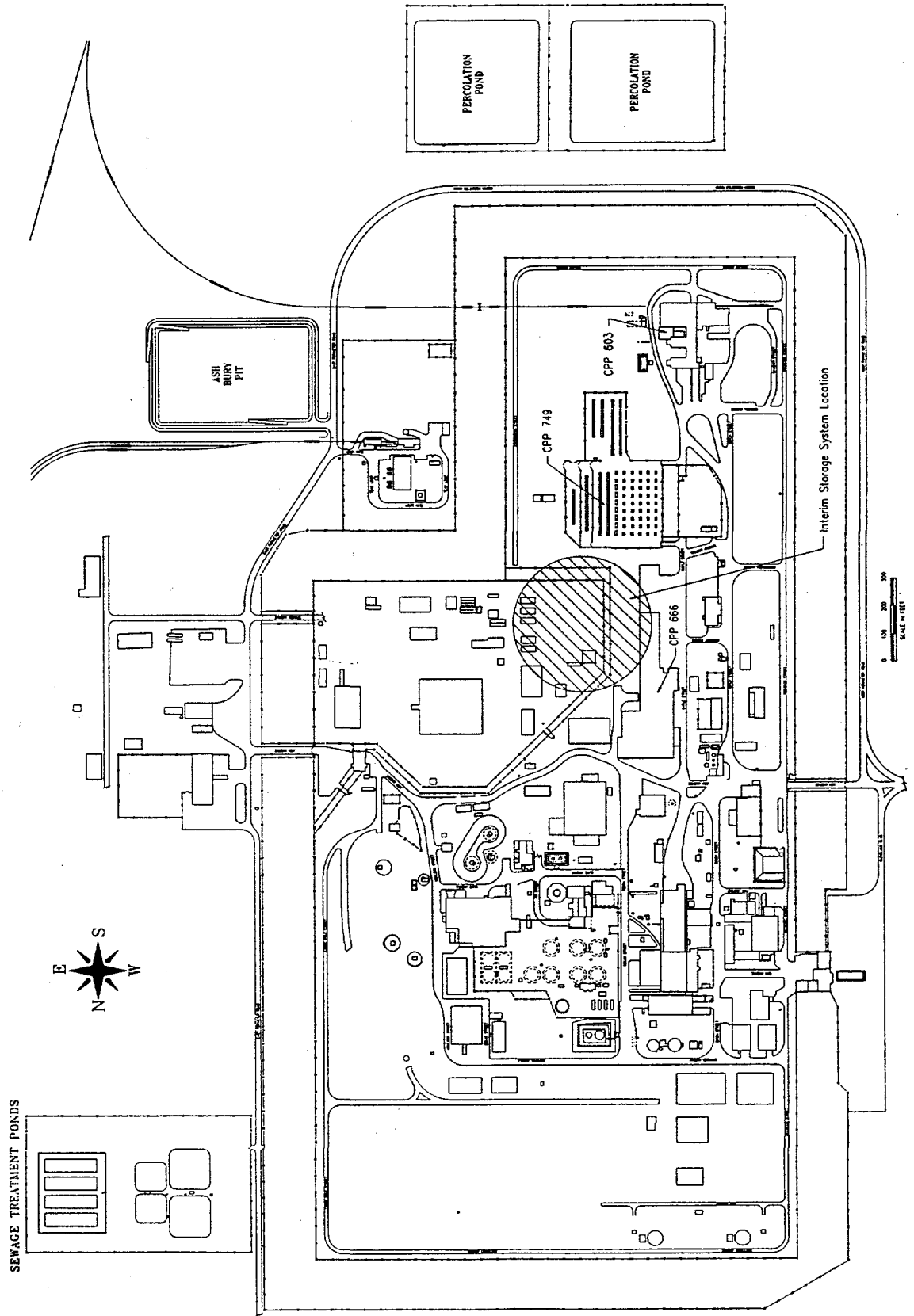

Figure 4. Proposed ISS location at ICPP.

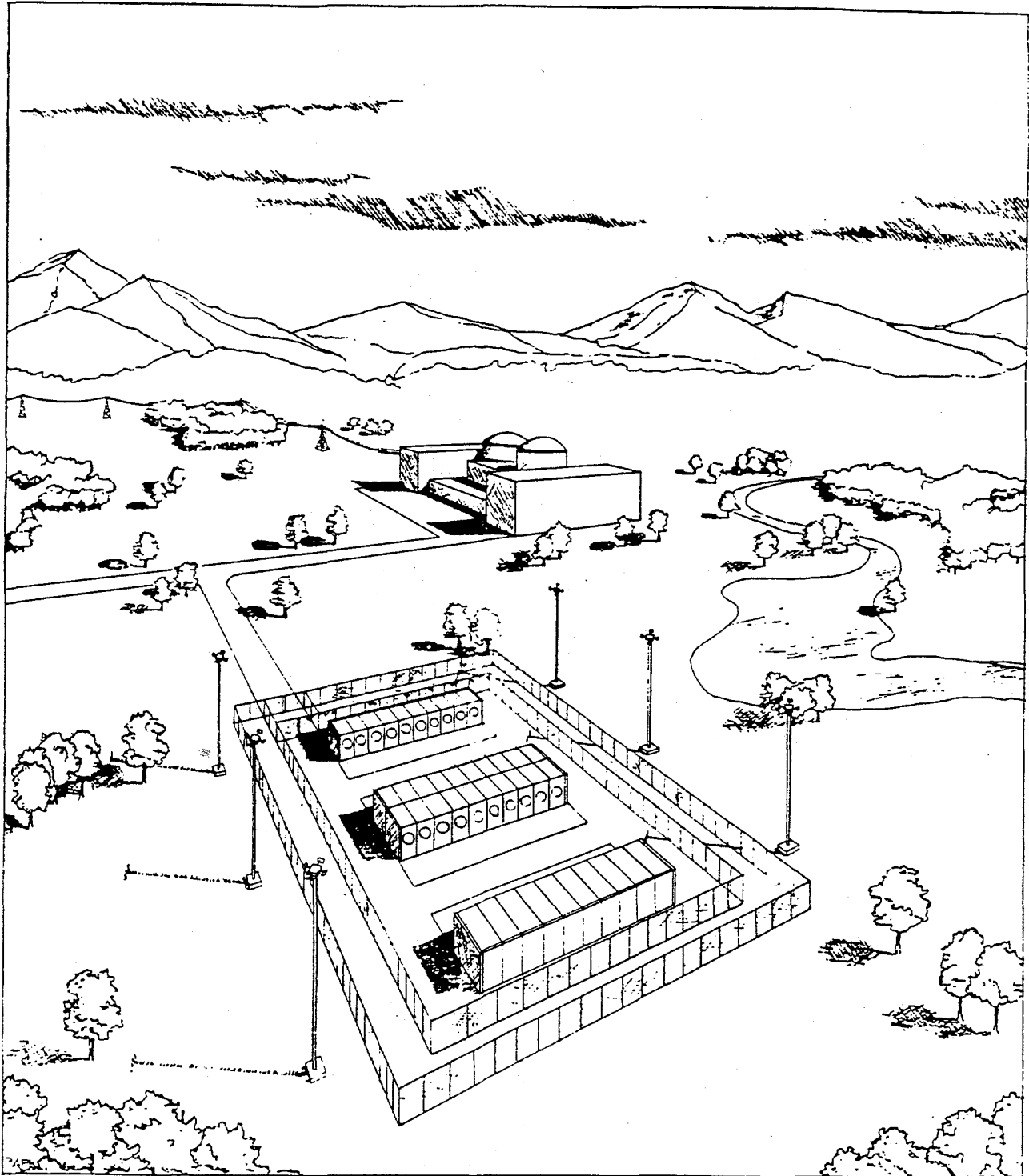

Figure 5. Illustration of Typical Life-of-Plant NUHOMS-® ISFSI (for information only).

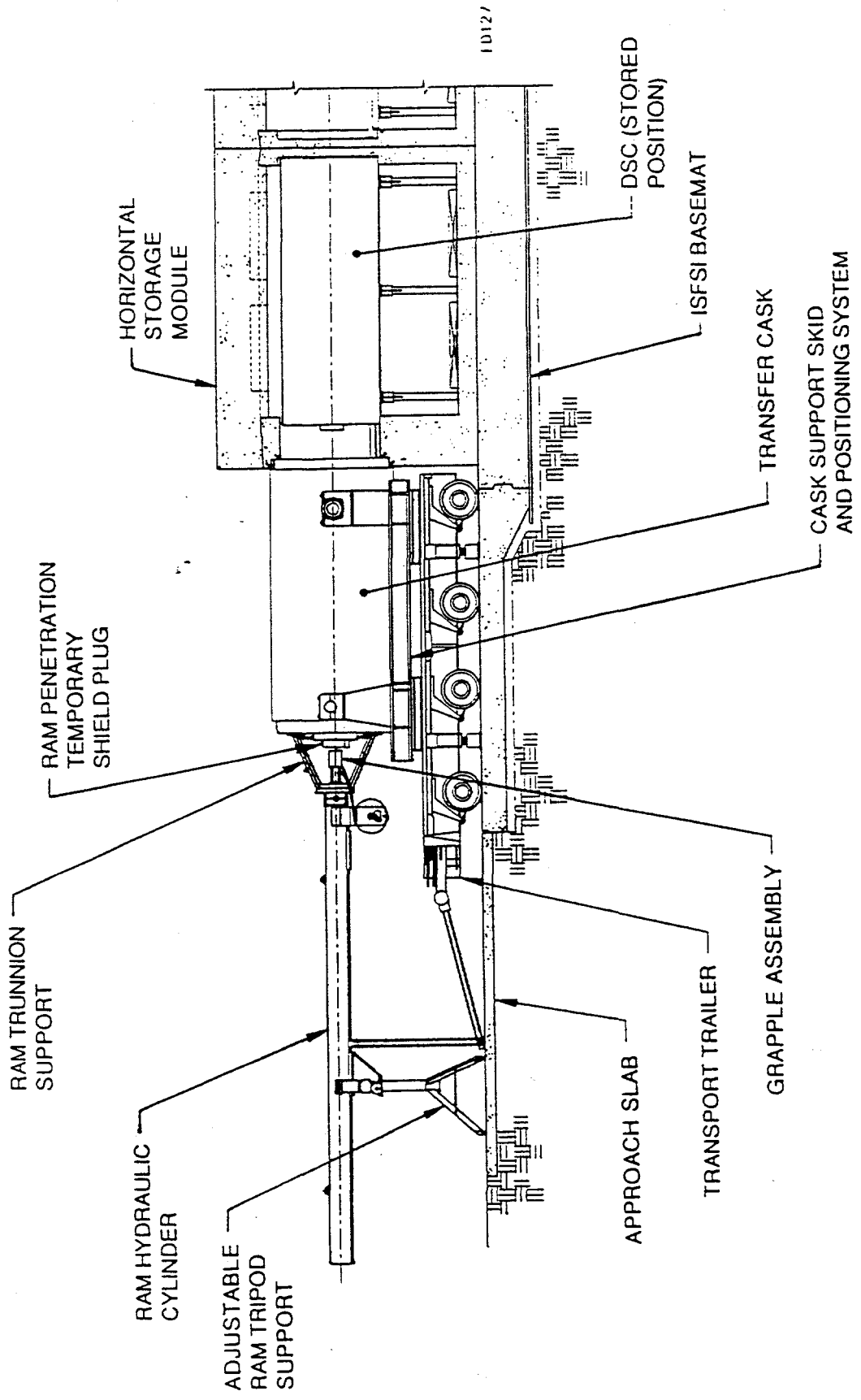

Figure 6. NUHOMS ® System Components Structures, and Transfer Equipment Elevation View.

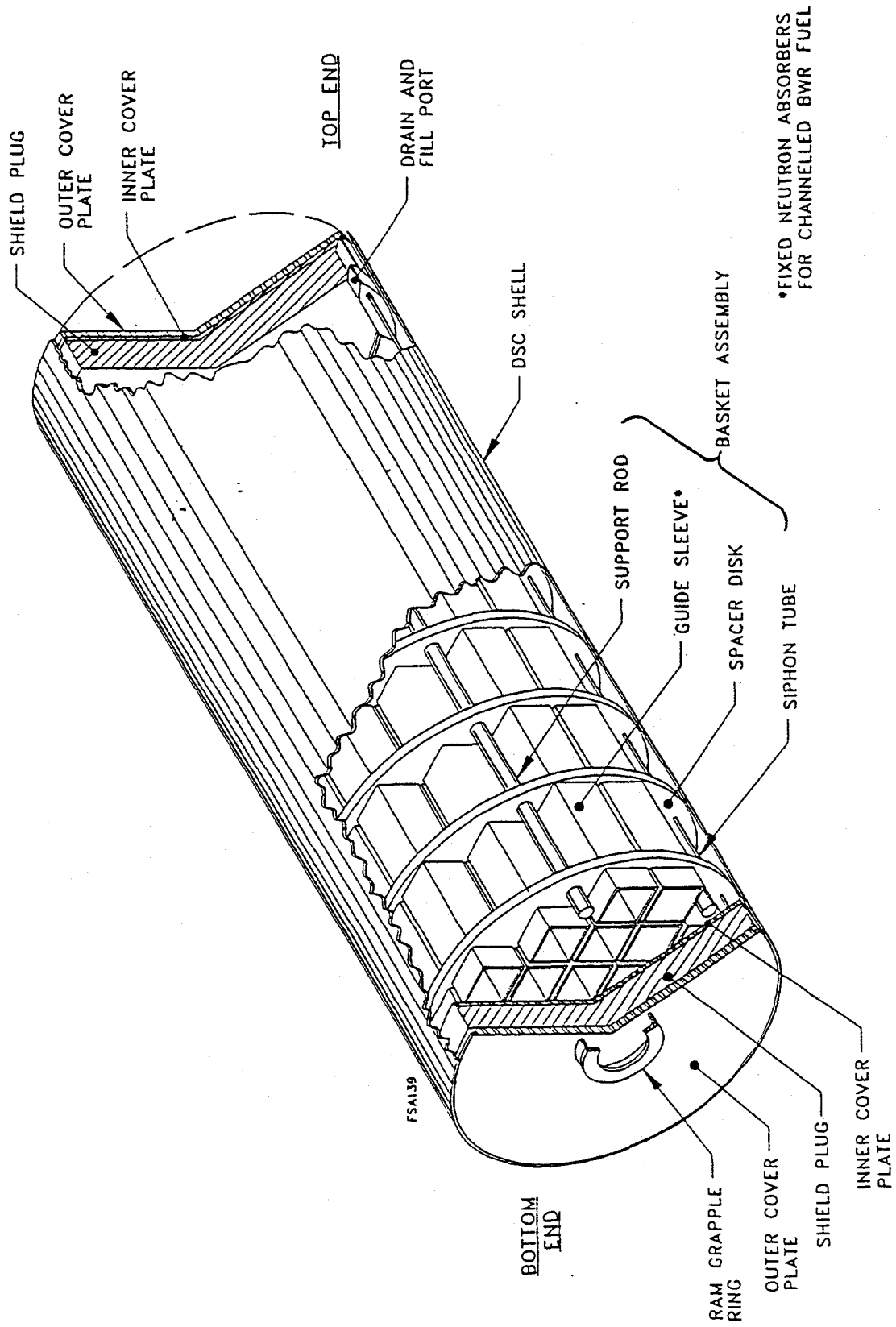
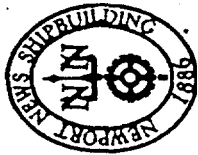

Figure 7. NUHOMS ® Dry Shielded Canister assembly Components.



VECTRA



◆ *The MP-187 is a transfer, transportation, and storage cask.*

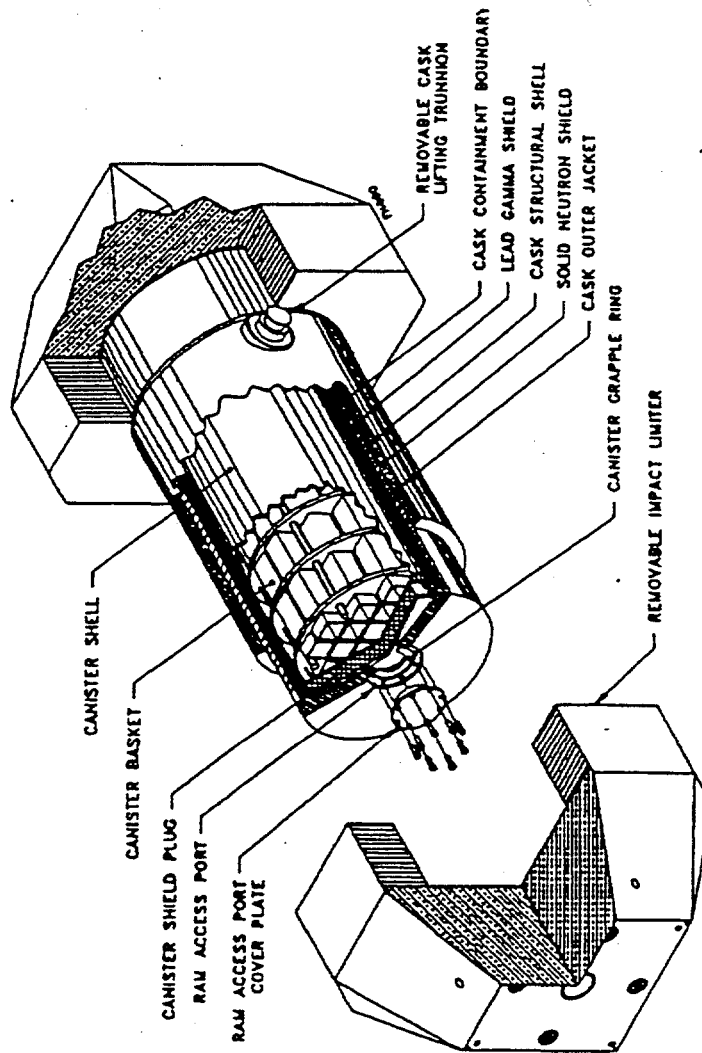

Figure 8. NUHOMS Trailer-Mounted MP-187 Transport Cask.

KEY

- 1 COOLING AIR INLET
- 2 CIVIL STRUCTURE OF THE STORAGE MODULE
- 3 STORAGE CONTAINER
- 4 CHARGEFACE STRUCTURE
- 5 SHIELD PLUGS
- 6 CASK LOAD/UNLOAD POSITION
- 7 FACILITY CRANE
- 8 WEATHER ENCLOSURE
- 9 COOLING AIR OUTLET STACK
- 10 COOLING AIR OUTLET

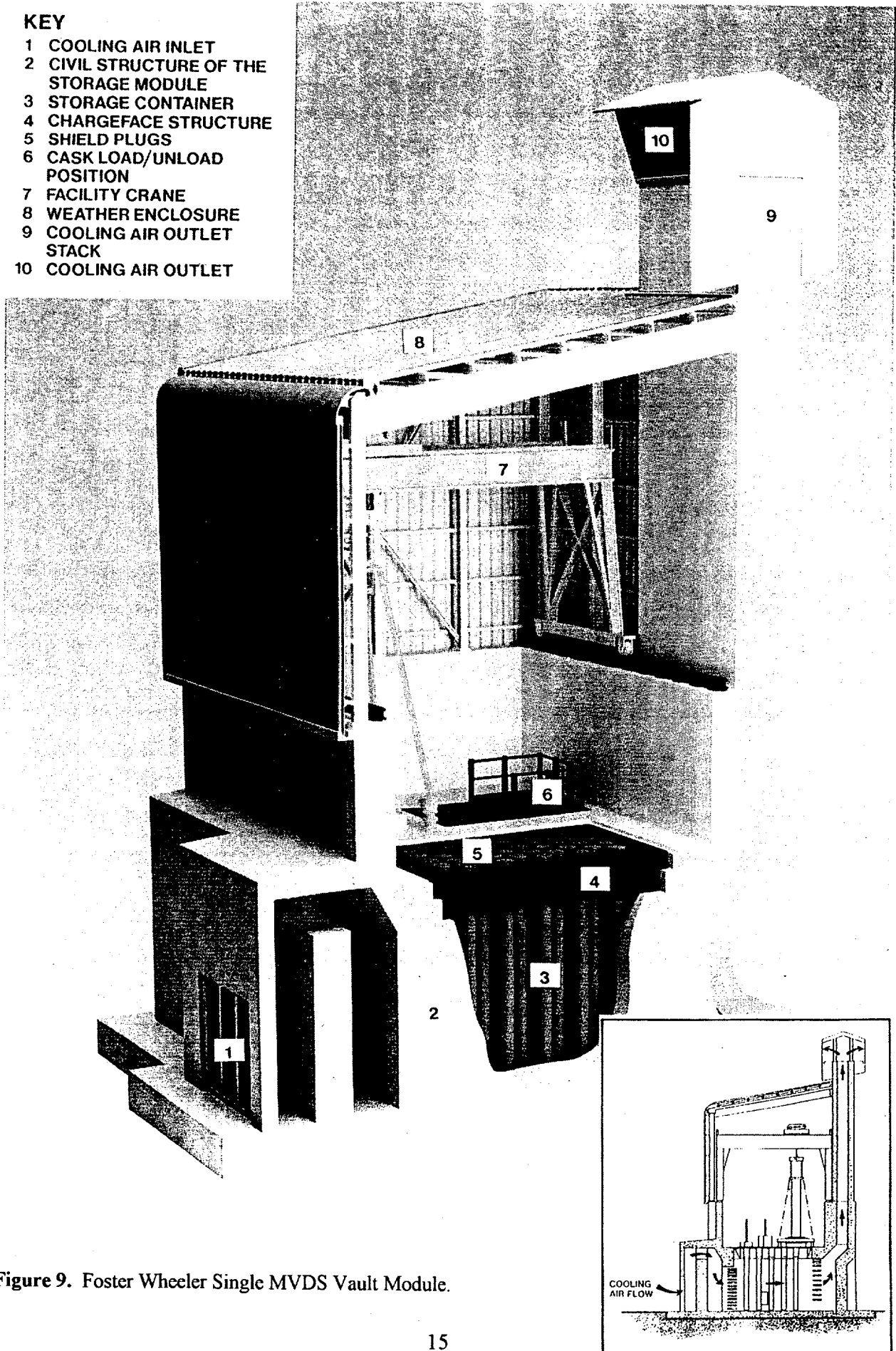

Figure 9. Foster Wheeler Single MVDS Vault Module.

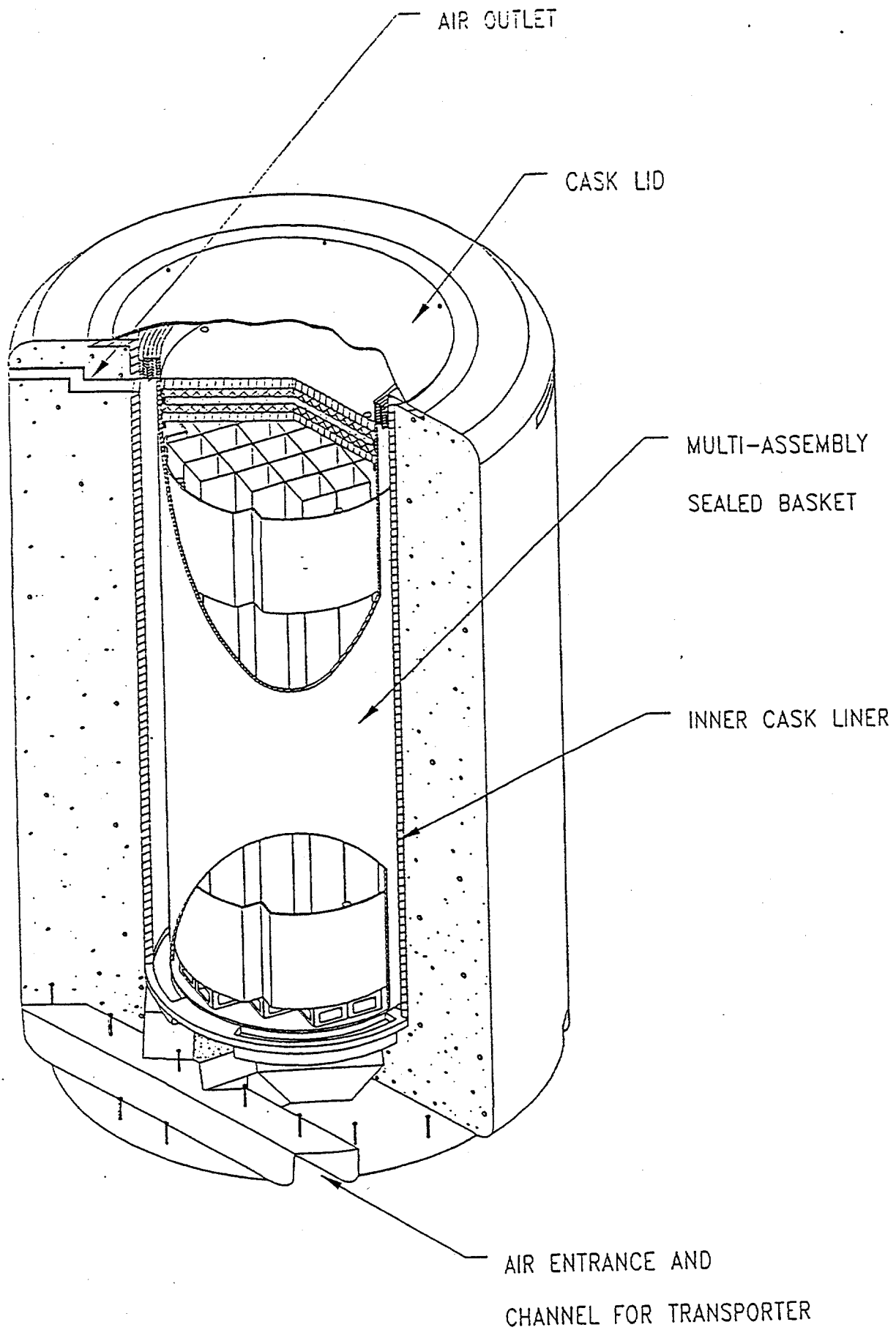

Figure 10. Sierra Nuclear Ventilated Storage Cask (VSC-24).

- b) Transporting water to ICPP for treatment and disposal through the LET&D and PEW. Transporting the water would require an estimated 160 vehicle round trips from TAN to ICPP and transportation would be conducted in compliance with DOT requirements. Residues from the treatment systems would be sent to the HLLW Tank Farm as discussed in (a).
- c) Reducing the volume of pool water through an evaporative system at TAN, stabilizing the residuals by macro encapsulation or another suitable method, and disposing of the residuals in the RWMC as LLW.
- d) Treating the water through an ion exchange or other suitable water treatment system at TAN, and discharging the treated water to (a) the TAN Technical Support Facility TSF-07 sewer system and associated pond or adjacent bermed water disposal area (Figure 11), (b) lined evaporation pond, or (c) directly to the land by a drip or sprinkler system.

2.2 Alternatives to the Proposed Action

This section describes the no action alternative and alternatives that were considered but dismissed from further consideration in this EA. These alternatives do not resolve issues associated with the need for action identified in Section 1.1.

2.2.1 No Action

The no action alternative is to continue storage of TMI core debris, commercial fuels, and hardware in the TAN Pool. The TAN Pool would remain operational. Regular surveillance, monitoring, and maintenance of the pool area and Hot Shop would continue. These activities may include: physical inspection; underwater video inspection to ensure no loss of structural containment or integrity; and routine analysis of pool water. The leak detection monitoring and corrosion inspection devices that have been installed to address some of the vulnerabilities discussed in Section 1.1 would remain operational. The TMI canisters and storage racks would require periodic requalification for continued underwater storage.

2.2.2 Alternatives Considered and Dismissed

2.2.2.1 Refurbish the TAN Pool. The TMI core debris and commercial fuels would be removed from the pool and placed into temporary storage. The pool would be upgraded to meet current standards. Suitable temporary storage facilities for the fuels and core debris do not exist at the INEL. Because the underwater design life of the TMI core debris canisters is 30 years, the integrity of the canisters would have to be reevaluated periodically. Continued storage in the TAN Pool would require the Hot Shop to remain operational.

2.2.2.2 Construct New Wet Storage. Construction of a new wet (underwater) storage pool would not meet the terms of the Settlement Agreement that requires DOE-ID to move SNF out of wet storage by 2023. In addition, wet storage facilities incur high construction and maintenance costs.

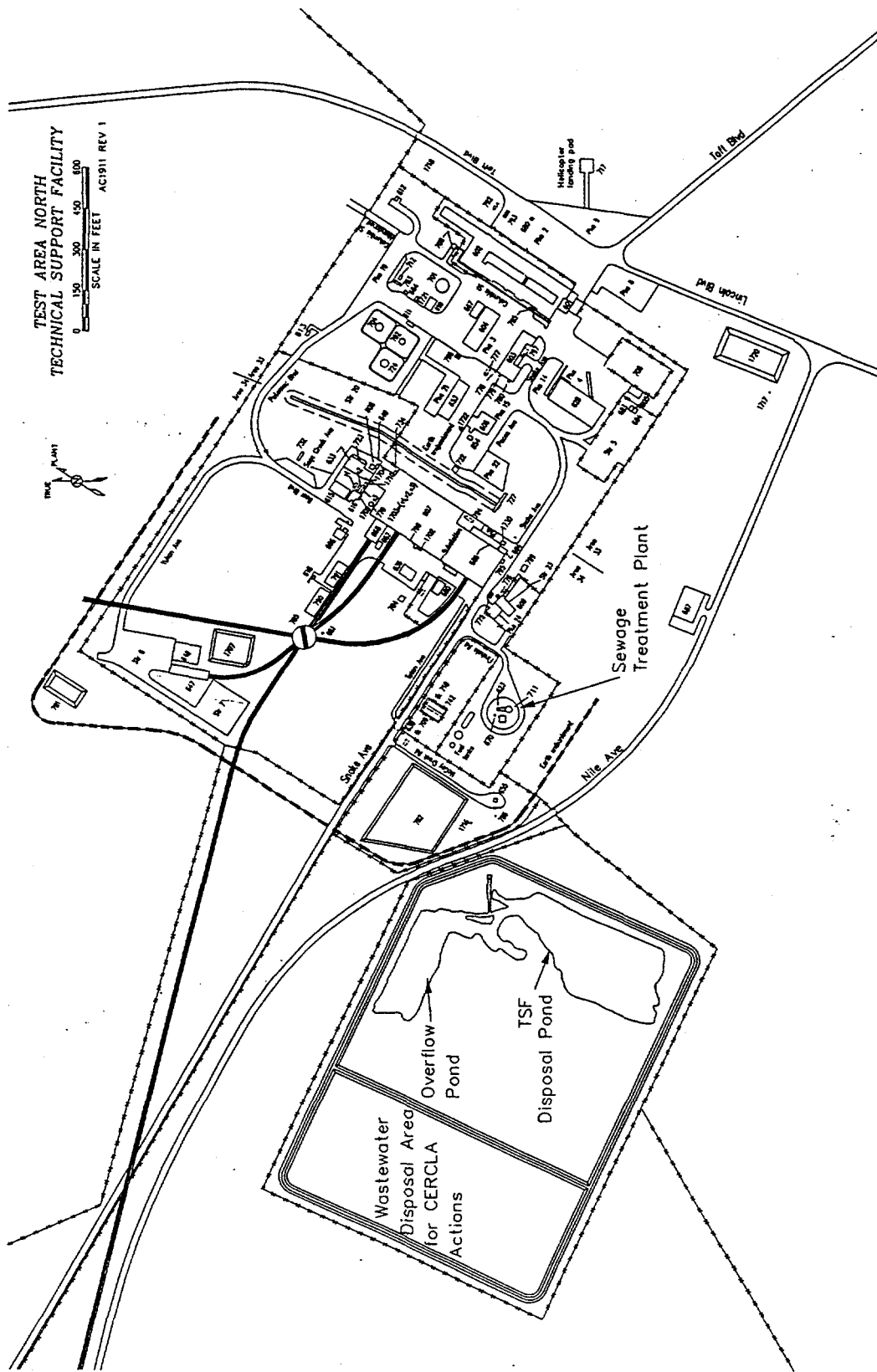

Figure 11. Location of TSF-07 disposal pond.

2.2.2.3 Store the TMI Canisters and LOFT and Commercial Fuels in Existing ICPP Storage Systems. This alternative would transport the TMI core debris and commercial fuels from TAN to ICPP, then transfer them to either underground dry vault storage (CPP-749) or the Irradiated Fuel Storage facility (IFSF) located at CPP-603 (Figure 4). This alternative was eliminated from further evaluation because there is insufficient vault space and there are other INEL fuels identified for storage in these vaults.

The IFSF is a shielded storage facility at ICPP and has 636 positions for canisters of SNF. There are currently 327 unused canister positions. The IFSF storage canisters are approximately 11-ft tall and 18 inches in diameter while the TMI canisters are approximately 12.5-ft tall and would extend approximately 18 inches above the IFSF vaults. There is not adequate space in the IFSF to transfer the TMI canisters into the IFSF canisters or for the necessary lifting and handling fixtures and tools. In addition, the TMI canisters are too tall for the shuttle bin, which transfers canisters from the handling cave to the storage area.

2.2.2.4 Construct an ISS at TAN. Construction of an ISS at TAN for the TMI and commercial fuel does not reflect the decision to consolidate SNF storage at ICPP as determined in the *Record of Decision for the FEIS* (DOE 1995a). This alternative was included in the May, 1995 version of this EA and was subsequently eliminated.

2.2.2.5 Construct an ISS at a Point Removed from above the Snake River Plain Aquifer. Paragraph E8 of the Settlement Agreement among DOE, the Department of the Navy and the State of Idaho (DOE 1995b) requires that DOE shall, after consultation with the State of Idaho, determine the location of dry storage facilities within the INEL, which shall, to the extent technically feasible, be at a point removed from above the Snake River Plain Aquifer, an EPA designated sole source aquifer. In accordance with this Agreement, a review was conducted to determine if there is such an alternative site on the INEL for the proposed ISS.

Figure 12 shows the boundaries of the INEL imposed over a map of the Eastern Snake River Basin and the Eastern Snake River Plain Aquifer. As shown on Figure 12, there are two locations on the INEL, the Birch Creek Area, and the Lemhi Range Area, that are not over the Snake River Plain Aquifer, but are still within the Eastern Snake River Basin or streamflow source area. These sites were also dismissed as one is near a geologic fault that could be considered a potential seismic threat. The other site was dismissed due to the parcel's proximity (1 mile) from a capable geological fault, steep slopes of the land, and potential habitat for sensitive species, proximity to private land, and visibility from highway 22. All precipitation that falls in the Eastern Snake River Basin that does not evaporate or is not transpired is transported by rivers and streams or flows underground to the Snake River Plain Aquifer.

The Birch Creek Area is located over an alluvial aquifer that provides recharge to the Snake River Plain Aquifer. The Lemhi Range Area encompasses the southern extension of the Lemhi Mountain Range which contains many intermittent stream channels that drain to the Snake River Plain Aquifer. Neither area would provide a construction site for the proposed ISS that is hydrologically isolated from the Snake River Plain Aquifer. Additionally, the development of either the Birch Creek or the Lemhi Range areas would require site preparation in undeveloped locations, access road construction and the extension of utility lines, all of which would cause environmental impacts. The negative environmental impacts and the cost of developing separate infrastructure in either the Birch Creek or Lemhi Range area would be much greater

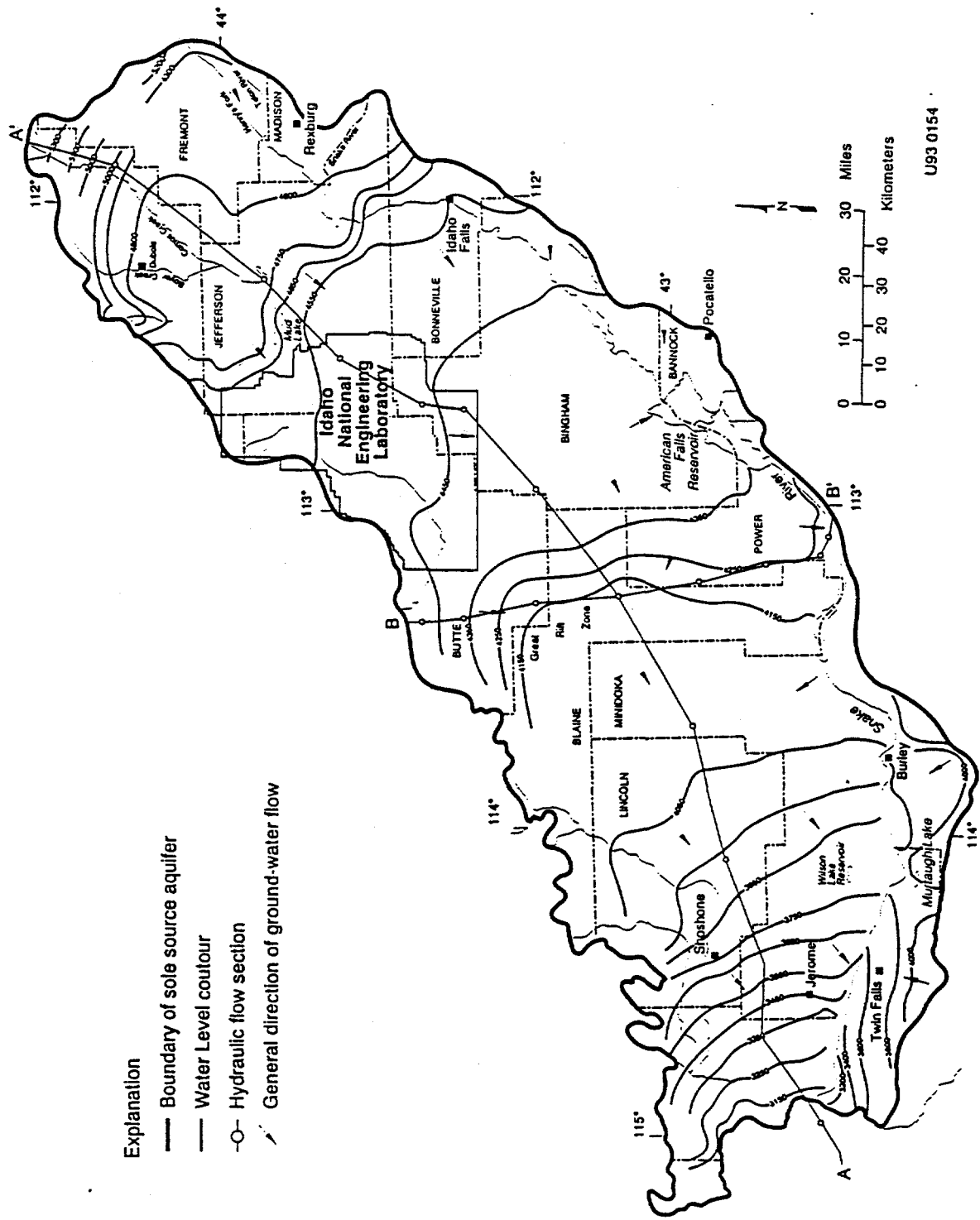

Figure 12. Eastern Snake River Plain and the Northern Part of the Snake River Basin (USGS1992).

than the construction of an ISS within the boundaries of an existing facility such as TAN or ICPP. For these reasons, the alternative of sighting the proposed ISS off the aquifer was eliminated from further consideration.

2.2.2.6 Dry the TMI Debris. Drying of the TMI debris, an option considered in the May, 1995 Draft version of this EA, has been eliminated from further consideration as a viable option for water removal from the TMI canisters. The intent was to completely dry the canisters to remove all entrained moisture and water of hydration to eliminate the potential for gas generation due to radiolysis which would facilitate storage in an unvented ISS. An analysis conducted using a test canister determined that it would be extremely difficult, if not impossible, to remove all water from the TMI canisters. Therefore, radiolysis potential would remain, and venting of the canisters would be required (Palmer 1995). Because the intent of the drying option was to allow storage in an unvented ISS, this option has been eliminated from further consideration.

3. AFFECTED ENVIRONMENT

The proposed action and alternatives would occur at ICPP and TAN, which are existing, developed facilities within the boundaries of the INEL. The INEL has been withdrawn from the public domain for the purpose of nuclear research and reactor testing. The INEL occupies 890 square miles in southeastern Idaho on the Eastern Snake River Plain. Public highways U.S. 20 and 26 and Idaho 22, 28, and 33 pass through INEL but off highway travel within the INEL and access to INEL facilities is controlled. A National Historic Landmark, Experimental Breeder Reactor-I, is located on the INEL and is open to the public. For an extensive description of the INEL's existing environment, please refer to the FEIS (DOE 1995). The FEIS conducted an extensive review of the INEL's affected environment and, in lieu of duplicating this discussion in this EA, the applicable FEIS sections are provided in Table 1. It should be noted that since the FEIS was published in April 1995, the gray wolf has been listed by the U.S. Fish & Wildlife Service as endangered; experimental/non-essential (USFWS 1995). The gray wolf may range on or near the INEL.

Table 1. Resource and FEIS (DOE 1995) Cross Reference

Resource	FEIS Reference (DOE 1995)
General Site Description	Volumes 1 and 2, Section 4.1
Land Use	Volumes 1 and 2, Section 4.2
Socioeconomics	Volumes 1 and 2, Section 4.3
Cultural Resources	Volumes 1 and 2, Section 4.4
Aesthetic and Scenic Resources	Volumes 1 and 2, Section 4.5
Site/Region Geologic Characteristics and Seismic Analysis	Volumes 1 and 2, Section 4.6 Volume 2, App. F-2
Air Resources, Climate, and Meteorology	Volumes 1 and 2, Section 4.7
Water Resources, Floodplain	Volumes 1 and 2, Section 4.8 Volume 2, Appendix F-2.2
Ecological Resources	Volumes 1 and 2, Section 4.9
Noise	Volumes 1 and 2, Section 4.10
Traffic and Transportation	Volumes 1 and 2, Section 4.11
Health and Safety	Volumes 1 and 2, Section 4.12
INEL Services	Volumes 1 and 2, Section 4.13

The INEL is located on the Eastern Snake River Plain, hereafter called the Plain. The surface of the Plain is comprised of sediments and basaltic lava flows. The lava flows range in age from 2,100 to 1.2 million years in the vicinity of the INEL. The youngest flows on the INEL have been dated at about

13,400 years old. The Plain has historically experienced few and small earthquakes and geologic evidence suggests that moderate earthquakes (magnitude 5.5 or less) at the INEL may have resulted from volcanic activity that ended 13,400 years ago. Basin and Range faulting adjacent to the plain has resulted in a higher rate of seismicity that can produce moderate to strong ground shaking at the INEL. Seismic hazards at the INEL include surface deformation (surface faulting, tilting) and ground shaking. Other potential seismic hazards (e.g., avalanches, landslides, mudslides, soil settlement, and soil liquefaction) are not likely to occur at the INEL because the local geologic conditions are not conducive to them (DOE 1995). The magnitude and frequency of these potential seismic events and their surface accelerations at the INEL have been quantitatively described in deterministic and probabilistic seismic hazard assessments for the ICPP and other INEL facilities. Additional analysis is underway in a probabilistic seismic hazard assessment. The ISS would be designed to meet the NRC seismic requirements of 10 CFR 72 "Licensing Requirements for the Independent Storage of Spent Nuclear Fuel and High-level Radioactive Waste."

There are no permanent residents on the INEL. ICPP is located 8 mi north of the INEL's southern boundary. The town nearest ICPP is Atomic City located approximately 13 mi to the southeast with a population of 25. The town nearest TAN is Mud Lake, located approximately 15 mi to the east with a population of 170. The total INEL work force in December 1995 was 8,294 and the number of employees at TAN and ICPP were 340 and 1,163 (respectively).

The areas within the fenced boundaries of ICPP and TAN have been surveyed for archaeological resources (Ringe 1993, and Reed et al. 1986). Both areas have been cleared in conjunction with earlier construction activities and no sites of archaeological or cultural importance were recorded.

Radiation in southeast Idaho in the vicinity of the INEL consists of natural background radiation from cosmic, terrestrial, and internal body sources; manmade nuclear fallout; and radiation from consumer and industrial products. These sources result in an estimated total effective dose equivalent (EDE) of 350 millirem/year (mrem/yr) to an average member of the public residing in southeastern Idaho (DOE 1993b). In 1991, the INEL added a potential $4.0E-03$ mrem/yr to the total background EDE^b (DOE 1993b). Doses were evaluated for historical releases from INEL operations (DOE 1991a) and a hypothetical offsite resident near the INEL boundary received an average dose of $5.4E-02$ mrem/yr above background from 1980 to 1989.

Surface water flows on the INEL consist of three intermittent streams (Big Lost River, Little Lost River, and Birch Creek) and localized runoff. The INEL is located in a closed basin and no surface waters flow from the site. The Snake River Plain Aquifer is the principal groundwater feature in southeastern Idaho, underlying nearly all of the Plain. The Snake River Plain Aquifer was designated a sole source aquifer by the Environmental Protection Agency. Aquifer depths within the INEL range from 200 to 900 ft. The depth to the aquifer at ICPP is approximately 450 ft and perched water has been found in the unsaturated zone at depths ranging from 40 to 377 ft. At TAN, the depth to the aquifer ranges from approximately 200 ft to over 350 ft.

b. To convert a number from scientific notation to its original form, multiply the base number times 10 raised to the given exponent. For example: to convert $3E-06$, multiply 3×10^{-6} , giving 0.000003 or 3/1 million.

There are no wetlands or 100 year floodplains located within the ICPP that would impact (or be impacted by) the action. The combination of local climate, relief, and geology provides the INEL with good natural flood-regulating characteristics. The Big Lost River is the only drainage to the INEL that provides any real flood threat to the ICPP. A flood diversion system near RWMC, constructed in 1958 and enlarged in 1984, protects INEL facilities such as ICPP from floods by diverting the floodwater to a basin that provides floodwater storage and infiltration. Based on an evaluation of the balance of storage and infiltration, the flood diversion system has the capability to accommodate the flood crest from the postulated 300-year flood (LITCO 1995a). The diversion system, therefore, is considered to provide adequate flood protection to the ICPP (LITCO 1995a) and the proposed ISS site. There are no siting limitations at the ICPP based on the 300 year floodplain, thus, the ISS is not anticipated to be affected. Snowmelt runoff on the INEL normally occurs January through March, while runoff from the surrounding mountains generally occurs in May or June. If the ground is frozen when snowmelt occurs, flooding can result because the infiltration capacity of soil is greatly reduced. In 1969 TAN experienced snow melt flooding caused by heavy rains and warm winds (Bishop 1993). The construction of dikes at TAN have controlled this source of flooding.

The impact to the ICPP of a maximum probable flood (MPF) was analyzed to provide a conservative flooding condition. The MPF is considered conservative as the last flood of the magnitude of an MPF occurred about 12,000 years ago during a wet climate cycle. The MPF scenario has flows estimated at 35,000 cubic feet per second (cfs) with a water velocity that would range from 0.6 to 3.0 feet per second on the INEL. This flood would result in shallow, slow-moving flood water within the ICPP-controlled area up to an elevation of 4916.6 ft. Based on elevations at ICPP, facilities that are in the northern half of the ICPP area would have approximately one to two feet of water while the southern end of ICPP would be above the MPF elevation (LITCO 1995a). Due to spreading and the resulting low velocity and shallow depth of the water, flooding would not pose a threat of structural damage to ICPP or TAN facilities (DOE 1995).

4. ENVIRONMENTAL IMPACTS

4.1 Impacts Associated with the Proposed Action

4.1.1 Construction Impacts

Impacts associated with construction of the proposed ISS at ICPP would be confined to approximately one acre of previously disturbed, undeveloped area. If contaminated soil is encountered during construction, the soil would be handled in accordance with INEL procedures. Radiological Control Technicians would be on duty to monitor excavation activities. Gravel used for fill material would be obtained from existing INEL borrow pits.

Excavation and leveling activities associated with construction would generate temporary local particulate atmospheric pollution in the form of dust and vehicular emissions. Dust suspension would be controlled with water sprays or other soil fixatives as necessary. Equipment for construction of the ISS would also produce a short-term increase in noise.

Nonradioactive solid waste generated from construction activities would be less than 300 ft³ and would be disposed of in the existing INEL landfill. This would be less than 1% of the total volume of waste disposed of annually in the INEL landfill complex. The landfill complex is expected to provide adequate solid waste disposal capacity for the INEL for the next 30 to 50 years (DOE 1995).

Archaeological resources are not expected to be encountered during construction. However, the INEL Cultural Resource Management Office would be consulted to assess the significance of artifacts should any be detected during construction. The INEL Cultural Resource Management Office would consult with the State Historic Preservation Officer (SHPO) and the Shoshone-Bannock Tribe, as necessary, to ensure appropriate follow-on actions. The National Historic Preservation Act (NHPA) of 1966 (See Section 5.0) requires agencies to consider the impact of activities on properties listed or eligible for listing in the National Register of Historic Places (36 CFR 800). The TAN Pool and Hot Shop are potentially eligible for this listing. There would be minimal impacts to the INEL's ecology because all construction impacts would be contained within the fenced boundaries of ICPP.

Groundwater at ICPP would not be affected by construction activities resulting from the proposed action. The construction would be conducted in accordance with requirements for storage and use of chemicals and construction materials so as to prevent potential contamination of the groundwater. The *Siting Analysis Summary for the TMI Debris and Commercial Fuel Interim Storage System* (Appendix B) also considered site suitability associated with factors such as adjacent ICPP land use, expansion capability, socioeconomics, aesthetics, access, transportation, utility (services) limitations, and impacts from adjoining facilities, and determined that there would be minimal adverse impacts associated with the proposed action.

4.1.2 Operational Impacts

4.1.2.1 Impacts to Air Quality

Existing TAN Pool Storage

The existing storage configuration of the TMI-2 core debris allows the emission of gaseous products generated from radiolysis of water within the canisters. The nature of the vent tubes (long, small diameter, water-filled) prevents emissions of any radionuclides in particulate form to the air above the TAN Pool. The pool air can enter the atmosphere via open doors, windows, and other diffusion processes. The existing configuration of the commercial fuel storage is not believed to contribute to a release of radionuclides because there is no mechanism for particulate matter resuspension or emission to the atmosphere in their current configuration.

Potential Emissions

Air quality impacts from the proposed action were included in an analysis of the canister dewatering at TAN and dry storage at ICPP (Staley 1996). Potential radionuclide inventory and release values are shown in Table 2 and used in the analysis. The CAP-88 computer code (EPA 1990), an EPA approved method of modeling NESHAP compliance, was used for calculating Effective Dose Equivalent (EDE) to the Maximally Exposed Individual (MEI).

Table 2. Potential Radionuclide Inventory and Releases

Nuclide	Ci in fuel	TAN storage release (Ci/yr)	Dewatering Release (Ci)	ICPP storage Release (Ci/yr)
H-3	7.68E +02	7.68E +01	3.00E +00	7.68E +01
Co-60	1.13E +04	3.58E -06	1.12E -05	6.16E -06
Kr-85	1.52E +04	1.52E +03	5.93E +01	1.52E +03
Sr-90	4.83E +05	1.53E -04	4.79E -04	2.63E -04
Y-90	4.83E +05	1.53E -04	4.79E -04	2.63E -04
I-129	1.15E -01	1.15E -02	4.49E -04	1.15E -02
Cs-134	2.43E +02	9.68E -08	3.03E -07	1.27E -07
Cs-137	2.82E +05	1.03E -04	3.22E -04	1.54E -04
Ba-137m	2.67E +05	9.72E -05	3.04E -04	1.45E -04
Eu-154	2.29E +03	7.25E -07	2.27E -06	1.25E -06
Pu-238	9.48E +02	3.00E -07	9.40E -07	5.16E -07
Pu-239	9.34E +03	2.96E -06	9.26E -06	5.09E -06
Pu-240	2.86E +03	9.05E -07	2.84E -06	1.56E -06
Pu-241	1.03E +05	3.26E -05	1.02E -04	5.61E -05
Am-241	4.67E +03	1.48E -06	4.63E -06	2.54E -06

Effective Dose Equivalent (EDE) to the Maximally Exposed Individual (MEI)

The EDE includes the 50-year Committed EDE from internal exposure through the ingestion and inhalation pathways and the external EDE from ground deposition and air immersion. The calculated EDE to the MEI are listed in Table 3 (Staley 1996). The estimated doses for the proposed action and the no action alternative (continued storage) are well below the NESHAP limit of 10 mrem/yr. A heating and ventilation system for the ISS is not anticipated to be required. Any potential emissions from an ISS air emissions control system (such as HEPA filters) would be evaluated in accordance with Section 5.0.

Table 3. EDE to MEI Due to Potential Airborne Releases from Existing Storage and the Proposed Action (Staley 1996).

Activity	EDE to MEI
Existing TAN Storage Pool	2.2E-03 mrem/yr
Proposed Dewatering Activity	2.4E-04 mrem/yr
Transport and Cask Receiving	0.0 mrem/yr*
Proposed ICPP ISS Dry Storage	4.0E-04 mrem/yr

* Canisters sealed during this time.

Emissions from Water Treatment and Discharge

Water treatment and discharge activities would not increase the total amount of radionuclide emissions from the INEL. There would be no radionuclide emissions from an ion-exchange treatment process because the system would be completely contained. The treatment system selected would be the best available technology that would remove the majority of the radionuclide constituents from the pool water. Although there is no known practicable method for removing tritium from liquid waste streams, the treatment and disposal operation would be designed and operated so that the tritium source and release would be considered in the ALARA (see Glossary) process. Discharging the treated water to an evaporation pond, land application, or an evaporative system, would release tritium to the atmosphere through evaporation of the discharged water. Worker exposures to tritium released by evaporation or volatilization from an unlined evaporation pond such as TSF-07, were modeled conservatively assuming the water would be discharged in the year 2001 and the entire volume of water would evaporate in one year. Exposure pathways were assumed to be inhalation and skin absorption. The dose to workers was determined to be 2.92×10^{-3} mrem or 2.92×10^{-6} rem, which is well below the worker dose limit of 2.0 rem/yr (Thorne 1995). Anticipated emissions of tritium (which has a half-life of 12.5 years) from the discharged water would result in doses that would cause no adverse health effects to the public.

Vehicular exhaust emissions would result from truck transport between ICPP and TAN. Approximately 50 round trips would be necessary to transport the TMI canisters and commercial fuel to ICPP and up to 160 round trips for transporting the pool water from TAN to ICPP (See section 2.1.3).

Foreseeable impacts from vehicular exhaust emissions are evaluated in the FEIS (DOE 1995). The FEIS indicates that vehicular exhaust emissions under any alternative would be below the applicable air quality standards, and could be attributed almost entirely to general traffic conditions. Therefore, in comparison, exhaust emissions resulting from the proposed action would contribute an inconsequential increase in vehicular-induced air impacts (DOE 1995).

4.1.2.2 Exposure to Radiation. TAN operations for TMI debris and commercial fuel removal, dewatering and loading would be conducted in accordance with DOE Orders. A radiological work permit would be required for activities that have a potential to expose workers, to ensure that work is conducted in a safe manner and that exposure would be kept ALARA. Worker doses would be monitored by dosimeters and the dose to a worker would not be allowed to exceed the applicable regulatory limits (10 CFR 835 and DOE 1995d).

The transportation from TAN to ICPP would be conducted so as to minimize radiation exposure. Specific criteria to limit radiation exposure during transport (10 CFR 71.47) include:

- 200 mrem per hour on the accessible external surface of the canister
- 200 mrem per hour at any point on the outer surface of the vehicle
- 10 mrem per hour at any point 2 meters from the vertical planes represented by the outer lateral surfaces of the vehicle.
- 2 mrem per hour in any normally occupied part of the vehicle.

Radiation exposures from the ISS at ICPP (Table 3) are below the limits identified in 10 CFR 72.104. This provides that during normal operations and anticipated occurrences, the annual dose equivalent to any individual who is located beyond the controlled area must not exceed 25 mrem to the whole body, 75 mrem to the thyroid and 25 mrem to any other organ as a result of exposure.

4.1.2.3 Waste Generation and Disposition.

4.1.2.3.1 Liquid Effluent— Approximately 780,000 gal. of water would remain in the TAN Pool following removal of the fuel bearing materials and hardware from the pool. Spectroanalyses of the pool water conducted in 1991 and 1992 identified the following concentration of radionuclides: $3.038\text{E-}06$ $\mu\text{Ci/mL}$ of cobalt-60 (Co-60), $7.7\text{E-}05$ $\mu\text{Ci/mL}$ Cs-137, and $2.0\text{E-}05$ $\mu\text{Ci/mL}$ of tritium. Derived concentration guides (DCGs) for these radionuclides from DOE Order 5400.5 are $3.0\text{E-}06$ $\mu\text{Ci/mL}$ for Cs-137 and $5.0\text{E-}06$ $\mu\text{Ci/mL}$ for Co-60. The maximum contaminant level (MCL) for tritium in drinking water is $2.0\text{E-}03$ $\mu\text{Ci/mL}$.

Upon removal of the debris, fuel, and equipment, the pool water would be analyzed to determine the appropriate treatment technology. If the treated water would be disposed of in the TSF-07 pond or adjacent associated bermed area, or by land application, disposal would be in compliance with Federal and State discharge requirements (see Section 5.0). Air emissions associated with treatment and discharge of pool water to an evaporation pond or by an evaporative system would be evaluated and may

require a PTC (see Section 5.0). Land application of the treated water would not have a negative impact on site ecology and may be used to irrigate vegetation and improve wildlife habitat.

4.1.2.3.2 Solid Waste—The TMI core debris, commercial fuels, and pool water are not RCRA regulated (LITCO 1995) and the proposed action is not anticipated to generate hazardous or mixed waste. However, if any hazardous or mixed waste is generated during dewatering operations or pool stabilization, the waste would be treated, stored, and disposed of in accordance with RCRA (40 CFR Parts 260-265) and the RCRA Land Disposal Restrictions (40 CFR Part 268).

The proposed action would generate nonradioactive and radioactive solid waste. An estimated 300 ft³ of solid nonradioactive waste would be disposed of in the INEL landfill complex. The estimated unconsolidated volume of solid nonincinerable radioactive waste generated would include 50 ft³ of upper support structures removed from the LOFT fuel assemblies; 200 ft³ of filters, removed particles, and resin beds from the water treatment system; and 17,000 ft³ of TMI six-pack storage modules and poison plates, LOFT storage containers, fuel storage coffins, and storage rack. This solid nonincinerable radioactive waste is LLW and would be sized (see Glossary) and disposed of at the RWMC. Radioactively contaminated incinerable solid wastes such as personal protective equipment would be sent to WERF. The INEL Landfill Complex, RWMC, and WERF have sufficient capacity to accept the solid wastes generated by the proposed action in addition to other INEL activities (DOE 1995), and the wastes would be disposed of in accordance with the respective facility's waste acceptance criteria.

4.1.2.4 Impacts On Socioeconomic Factors and Biological and Cultural Resources.

The proposed action would not require a permanent increase in the number of INEL employees. Activities at TAN associated with dewatering, preparation for transport, and pool stabilization would require an average of 10 workers over the project's life. ISS construction at ICPP would require an average of 20 construction workers on the site for approximately 1 year. Temporary increases in workers would have minimal impact on regional socioeconomics. The DOE operating contractor would be responsible for managing the ISS operations upon completion of construction activities.

The ISS site is within facility boundaries and has been cleared and graded in conjunction with previous construction activities. There is no unique or critical habitat involved and there would be no adverse impact to wildlife or vegetation or any listed threatened or endangered species. A biological assessment would not be required (Reynolds, 1993).

There would be no impacts to cultural resources resulting from the proposed action. No part of the proposed action would result in modification of the TAN 607 structure that would affect its eligibility for listing on the National Register of Historic Places.

4.1.3 Potential Impacts from Accidents

4.1.3.1 Potential Handling Accidents. The accidents described in this Section provide the bounding accident analysis associated with handling of canisters and commercial fuel for the proposed action. These potential accident scenarios were initiated by an earthquake (with an occurrence frequency of once in 10,000 years) that would occur during dewatering and loading operations in the Hot Shop

(Abbott 1992). Conservative estimates of radionuclide releases (Table 4) and dose impacts (Table 5) were evaluated for:

- A single TMI canister drop during crane transfer within the Hot Shop.
- A single commercial fuel assembly drop during transfer within the Hot Shop.

The dose from the dropped TMI canister accident was calculated using a filter canister since these are the only ones that contain particles small enough to be aerosolized. The release fractions assumed for the dropped canister accident were 1.0 for Dr-85 and H³, 0.3 for I-129, and 0.01 for dispersable solids in the canister. For these calculations, 10% of the core debris in the filter canisters was assumed to be dispersable solids with a diameter less than 10E-09. The dose from the dropped commercial fuel assembly accident is based on calculations using a commercial reactor spent fuel assembly. The LOFT fuels have a much lower burnup than commercial fuel, which would result in smaller fission product inventories and, therefore, smaller potential releases of radionuclides (Peterson 1991). The impact from the assembly drop is assumed to rupture 100% of the fuel rod cladding but not crush the fuel matrix. The gaseous fission products present in the fuel-clad gap would be released, but there would be no releases of solid fission products because they are contained within the fuel matrix. The amounts of gaseous fission products in the commercial fuel assembly were calculated using the ORIGEN2 computer code (DOE 1987) and a 10-year decay period. The gaseous fission product inventory in the fuel assembly was calculated to be 195 Ci of tritium, 0.634 Ci of carbon-14, and 2,060 Ci of Kr-85. Thirty percent of the total inventory in the assembly is assumed to be present in the fuel-clad gap and would be released (Table 5).

The RSAC-4 code was used to model radionuclide air dispersion and environmental transport because it is a site-specific code with the capability to evaluate short-term accident releases. For the scenarios, it was conservatively assumed the Hot Shop ventilation and filtration system would fail and radionuclides would be released to the atmosphere at ground level. Worst-case dispersion conditions of stability class F and a wind speed of two meters per second were assumed.

The handling accident involving a dropped fuel assembly produced a calculated dose to the maximally exposed individual of 1.1 rem. This dose is about 6 times greater than the dose calculated for a dropped TMI canister. For the dropped fuel assembly accident, the probability of inducing a fatal cancer in the maximally exposed individual would be about one chance in 1,800, so no adverse health effects to the MEI would be anticipated. The potential for an accident and associated dose consequences will be reduced by limiting access to the Hot Shop during operations, using remotely operated equipment, as practical, and controlling activities in accordance with written procedures.

An accident scenario based on a fuel assembly or TMI canister drop during transfer activities into an ISS at ICPP was not analyzed because a breach of a DOT approved SNF transport cask is incredible (less than 1 in a million) and the ISS would be designed to withstand a design basis seismic event or dropped storage canister.

Table 4. Upper-bound estimates of airborne radionuclides (curies/accident) resulting from postulated accidents of the proposed action during Hot Shop operations.

Radionuclide	Dropped canister (Ci/accident)	Dropped Fuel assembly (Ci/accident) ^a
Tritium (H-3)	2.80E+00	5.85E+01
Carbon (C-14)	—	1.90E-01
Krypton (Kr-85)	5.73E+01	6.17E+02
Iodine (I-129)	1.00E-04	0
Cobalt (Co-60)	1.08E-01	0
Strontium (Sr-90)	1.55E+00	0
Yttrium (Y-90)	1.55E+00	0
Cesium (Cs-134)	2.62E-03	0
Cesium (Cs-137)	9.01E-01	0
Barium (Ba-137m)	8.53E-01	0
Europium (Eu-154)	9.15E-03	0
Plutonium (Pu-238)	2.86E-03	0
Plutonium (Pu-239)	2.72E-02	0
Plutonium (Pu-240)	8.34E-03	0
Plutonium (Pu-241)	3.62E-01	0
Americium (Am-241)	1.16E-02	0

a. The dropped fuel assembly scenario assumes that the fuel rod cladding will be ruptured and that gaseous fission products in the fuel-clad gap will be released. The fuel matrix is not crushed, so there is no release of solid fission products.

Table 5. Summary of radiological effects from releases due to accident scenarios

Accident Scenario	Exposure Pathway	Effective Dose Equivalent (rem)			
		Hot Shop Worker	Onsite Worker @ 100-m	Onsite Worker @ 300-m	Maximally Exposed Individual ^a
Canister Drop	Inhalation	0 ^b	3.8E-01	3.7E-01	5.1E-02
	Ingestion	0 ^c	--	--	1.2E-01
	Ground Surface		3.1E-03	3.0E-03	4.2E-04
	Immersion		8.7E-06	8.5E-06	1.2E-06
	TOTAL		0	3.8E-01	3.7E-01
Fuel Assembly Drop	Inhalation	0 ^b	7.3E-05	7.2E-05	9.9E-06
	Ingestion	0 ^c	--	--	1.1E+00
	Ground Surface		0	0	0
	Immersion		1.3E-05	1.3E-05	1.7E-06
	TOTAL		0	8.6E-05	8.4E-05
Health effects (number)^d					
Canister drop		0 ^b	1.52E-04	1.48E-04	8.5E-05
Fuel assembly drop		0 ^b	3.4E-08	3.7E-08	5.5E-04

a. Nearest Site Boundary (6.4 miles east-northeast of TAN)

b. Workers will not be present in Hot Shop during canister/fuel transfers.

c. Worker doses do not include the ingestion pathway as no agricultural products are produced on the INEL.

d. Health effects are defined as the latent cancer fatalities. A conversion factor of 4E-04 cancer fatalities/person-rem for worker exposure and 5E-04 cancer fatalities/person-rem for public exposure was used for this analysis (10 CFR 20, "Standards for Protection Against Radiation: Final Rule," May 21, 1991).

4.1.3.2 Transportation Accidents. The FEIS (DOE 1995) analyzed transportation accidents associated with onsite SNF shipment. The FEIS analysis provides a "bounding" estimate of the annual probability of fatal cancers occurring in the local population due to a transportation accident. However, potential accident impacts associated with transportation of the TMI debris and commercial fuels would be lower than the FEIS bounding scenario. This is due to the nature of the material (See Section 1.2); the rigorous onsite mitigative measures for SNF transport (DOE 1995); and the DOT and NRC requirements for SNF transport.

4.1.3.3 Potential for Accidents During Storage. The basic design features of an ISS would mitigate the effects of casualty events from a design basis accident (see Glossary) for an earthquake, tornado, flood, fire, toppling or dropping accidents, and filter failure. In all these events, the design would prevent loss of containment, shielding, or criticality control (LITCO 1995b). The ISS would be designed to accommodate gas generation (hydrogen and oxygen) from radiolysis of water in the canisters and storage system.

4.1.4 Cumulative Impacts

The radiological releases from current and future INEL operations (DOE 1995) to the worker, MEI, and the population within 50 miles of the INEL are identified in Table 6. The incremental and cumulative 10 year dose (from 1995-2005) includes emissions associated with the TAN Pool Stabilization Project. Based on exposure for the cumulative 10 year dose, the risk to an INEL worker at the location of highest dose from airborne radionuclide emissions would cause an estimated increased lifetime chance of developing fatal cancer of less than 1 in 500,000. The occupational radiation dose received by the entire INEL workforce (about 10,000 workers) over the 10 years would result in less than 1 fatal cancer. For comparison, the natural lifetime incidence of fatal cancers in the same population from all other causes would be about 2,000 (DOE 1995). Radiological dose impacts to the MEI were conservatively summed to derive cumulative impacts, although the location of the MEI may be different for each source. This conservatism serves to establish the upper-bounding dose. Despite this conservatism, the dose to the MEI is low (Table 6) and would result in a fatal cancer risk for the MEI of less than 1 occurrence in 300,000. The cumulative 10 year dose from INEL activities from 1995 through 2005 would result in an increase of less than one fatal cancer in the population within fifty miles of the INEL (DOE 1995). The natural lifetime incidence of fatal cancers in the same population from all other causes would be about 24,000 out of a population of 120,000. Radiological releases resulting from the proposed action, present INEL operations, and the future actions would not be expected to cause adverse health effects to workers, the MEI, or the general public.

Increases in nonradiological atmospheric pollutants would consist of temporary localized releases associated with construction of the storage system and vehicular emissions during transportation. These emissions would not measurably add to time-averaged ambient air concentrations of pollutants at the INEL (DOE 1995).

Cumulative impacts associated with waste generation would be minimal. The INEL Landfill Complex, RWMC, and WERF have sufficient capacity to accept the wastes generated by the proposed action in addition to other INEL activities (DOE 1995). It is anticipated there would be no increase in the amount of hazardous or mixed wastes generated on the INEL that would result from the proposed action.

Table 6. Radiological Air Emission Baseline and Ten-year Dose (DOE 1995).

	INEL baseline annual dose	Incremental Ten year dose^{a b}	Cumulative Ten year dose^{a b}
Site worker (maximally exposed worker ^c)	.32 mrem	1.4 mrem	4.6 mrem
Offsite individual (MEI)	.05 mrem	5.8 mrem	6.3 mrem
Population within 50 miles ^d	.30 mrem	26.0 mrem	29.0 mrem
Natural Background	350 mrem		3,500. mrem

a. Includes the Pool Stabilization Project.
b. Based on implementation of projects in the FEIS (DOE 1995) from 1995 to 2005.
c. The maximally exposed worker is located at the Test Reactor Area.
d. Cumulative radiation dose (person-rem) to the population within 50 miles of site facilities from INEL operations from 1995 to 2005.

Cumulative socioeconomic impacts during construction or operation of the ISS would not be expected. The work force for this project would be drawn from existing INEL employees or commercial vendors contracted to design and construct the system. Changes in INEL employment resulting from the proposed action would be within normal fluctuations in INEL employment.

The proposed action would not contribute to cumulative impacts to biological resources. Activities associated with the proposed action would occur within the boundaries of existing facilities at the INEL.

The construction and operation of an ISS would consume irretrievable amounts of electrical energy, fuel and miscellaneous chemicals and indefinitely commit concrete, metals, plastics, lumber, sand, and gravel and a fraction of the water used in construction (DOE 1995). The proposed action would occur within the boundaries of existing industrial facilities and transportation would occur over an existing road that is adequate to support cask transport. Scarce or strategic material would not be used for the construction of the ISS.

4.2 Impacts Associated with the No Action Alternative

Annual airborne radionuclide emissions from the entire TAN facility are estimated to be 0.12 Ci (DOE 1995). Emissions from the TAN Pool and TAN-607 facility would not change as a result of the no action alternative.

There is no evidence of deterioration of concrete in the TAN Pool. Data from the leak detection system indicates that there is no evidence of any water leakage. A seismic evaluation of the TAN Pool vestibule (Lacey 1994) determined the vestibule would prove adequate for a design basis (see Glossary)

earthquake. The analysis found that the vestibule would withstand an earthquake having a peak spectral acceleration of about 0.43g with no damage or leaks. For comparison, a maximum horizontal ground surface acceleration of 0.24g at the INEL is estimated to result from an earthquake that could occur once every 2,000 years (DOE 1995). While no seismic evaluations of the pool have been performed, the pool is similar in construction to the vestibule. Therefore, it may be inferred that a design basis earthquake will not result in cracking or leaking of the TAN Pool.

An event causing the water in the pool to drain, all mitigation responses to be ineffective (emergency water replacement systems unable to maintain water above the TMI canisters), and radiation sources in the pool to be exposed was analyzed (Rohrig, 1991). Resultant radiation levels at 6.6 ft above the empty pool ranged from 1.5 to 7 rad/hr at the pool edge and 13 to 45 mrad/hr at 82 ft away from the edge of the pool. Radiation entering the Hot Shop from the pool was not a concern as there are administrative and evacuation measures that require workers to leave the Hot Shop if an incident occurs.

Although the TAN Pool, in its current condition, poses minimal threat to human health and the environment, the no action alternative would not ensure compliance with the Settlement Agreement (DOE 1995b). The TAN Pool ventilation system is not adequate and there is no secondary containment system for the TAN Pool water. Continued use of the pool storage could require extensive modifications to meet environmental and safety requirements. Additionally, storage of the TMI core debris in the TAN Pool would require continuing maintenance of the Hot Shop and pool until the ultimate storage location or disposition of the TMI core debris is determined.

5. PERMIT AND REGULATORY REQUIREMENTS

Prior to project implementation, an air emission evaluation would be conducted to determine air permitting requirements (IDAPA 1996a) applicable to the project. A PTC, if required, would address potential emissions associated with the fuel and debris removal from the TAN Pool and the operation of the ISS. Following removal of the commercial fuel, debris and hardware from the pool, an air evaluation of the pool water treatment and disposal process would be conducted and required air permits would be obtained.

Radionuclide emissions from DOE facilities are regulated under the 40 CFR Part 61, NESHAP, at Subpart H. The EPA requires a NESHAP approval if the modeled EDE is above 1% of the 10 mrem/yr standard (0.1 mrem/yr). Based on a NESHAP evaluation (Zohner 1995), the potential EDE to the MEI was calculated and found to be less than the 0.1 mrem/yr standard. Therefore, a NESHAPs application to construct is not required.

Surface land application of the treated pool water could require an Idaho Wastewater Land Application Permit in accordance with the Idaho Wastewater Land Application Permit Requirements (IDAPA 1996b). Surface land application of the pool water would require treatment to meet the release criteria, as defined by State or Federal requirements at the time of treatment, for discharge of liquid effluent with radionuclides. Discharges would also be required to meet DOE Order 5400.5 (DOE 1993c) and 10 CFR 835.

A stormwater pollution prevention plan would be completed before construction of the ISS at ICPP. The plan would be prepared in accordance with the *INEL Stormwater Pollution Prevention Plan* (DOE 1993d) and the regulations for "National Pollutant Discharge Elimination System (NPDES) General Permit for Stormwater Discharges Associated with Construction Sites" (40 CFR 122 *et. seq.*) The purpose of a storm water pollution prevention plan is to prevent erosion products and sediment from running off the site during construction.

Following are the major laws, regulations and other requirements that would be applicable to the proposed action analyzed in this EA. Detailed summaries of these laws can be found in the Volume 1, Chapter 7 of the FEIS (DOE 1995) which is incorporated by reference.

- National Environmental Policy Act of 1969, as amended (42 USC §4321 *et seq.*)
- Atomic Energy Act of 1954, as amended (42 USC §2011 *et seq.*)
- Nuclear Waste Policy Act of 1982, as amended, (42 USC §10101-10270).
- Clean Air Act, as amended (42 USC §7401 *et seq.*)
- Safe Drinking Water Act, as amended (42 USC §300 {F} *et seq.*)
- Clean Water Act, as amended (33 USC §1251 *et seq.*)
- Resource Conservation and Recovery Act, as amended (42 USC §6901 *et seq.*)
- Comprehensive Environmental Response, Compensation, and Liability Act, as amended (42 USC §9601 *et seq.*)
- Emergency Planning and Community Right-to-Know Act of 1986 (also known as "SARA Title III") (42 USC §11001 *et seq.*)
- Toxic Substances Control Act (15 USC §2601 *et seq.*)

- Pollution Prevention Act of 1990 (42 USC §13101 et seq.)
- Federal Facility Compliance Act (42 USC §6921 et seq.)
- National Historic Preservation Act, as amended (16 USC §470 et seq.)
- Archaeological Resource Protection Act, as amended (16 USC §470aa et seq.)
- Native American Grave Protection and Repatriation Act of 1990 (25 USC §3001).
- American Indian Religious Freedom Act of 1978 (42 USC §1996).
- Religious Freedom Restoration Act of 1993 (42 USC §2000bb et seq.)
- Endangered Species Act, as amended (16 USC §1531 et seq.)
- Migratory Bird Treaty Act, as amended (16 USC §703 et seq.)
- Bald and Golden Eagle Protection Act, as amended (16 USC §668-668d).
- Occupational Safety and Health Act of 1970, as amended (29 USC §651 et seq.)
- Noise Control Act of 1972, as amended (42 USC §4901 et seq.)
- Hazardous Material Transportation Act (49 USC §703 et seq.)
- Solid Waste Disposal Act as amended by the Resource Conservation and Recovery Act (42 USC §6901 et seq.)

6. AGENCIES AND PERSONS CONSULTED

The U.S. Fish and Wildlife Service (USFWS) furnishes DOE-ID with a list of threatened and endangered species at the INEL (USFWS 1995). After review of the proposed action and species list, a biological assessment determination is issued. No biological assessment is needed for the proposed action as stated in Section 4.1.2.4. This EA has been revised to respond to public and State of Idaho comments that were provided during the 2 public comment periods (See Appendix A). A section has also been added to the EA to address siting the proposed ISS off the aquifer in response to Section E8 of the Settlement Agreement (DOE 1995b).

7. REFERENCES

1. Abbott, M. L., 1994, "Radiological Impacts Analysis for the Dry Cask Storage Project Environmental Assessment", MLA-22-92, October 13
2. Akers, D. W., E. L. Tolman, P. Kuan, and D. W. Golden, 1988, "Three-Mile Island Product Inventory Estimates," *Nuclear Technology Journal*, Vol. 87, August
3. Bishop, C. W., 1993, Water Resources, in: Irving. J. S., *Environmental Resource Document for the INEL*, Volumes 1 and 2, EGG-WMO-10279, EG&G Idaho July
4. DOE, 1987, *Characteristics of Spent Fuel, High-Level Waste, and Other Radioactive Wastes Which May Require Long-Term Storage*, Office of Civilian Radioactive Waste Management, DOE/RW-0184
5. DOE, 1991a, *Idaho National Engineering Laboratory Historical Dose Evaluation*, DOE/ID-12119, Vol. 1, August
6. DOE, 1993a, *Spent Fuel Working Group Report on Inventory and Storage of the Department's Spent Nuclear Fuel and other Reactor Irradiated Nuclear Material and their Environmental, Safety and Health Vulnerabilities*, Volume 1, U. S. DOE, November
7. DOE, 1993b, *The Idaho National Engineering Laboratory Site Environmental Report for Calendar Year 1992*, DOE/ID-12082(91), June
8. DOE, 1993c, "Radiation Protection of the Public and the Environment," DOE 5400.5, Chg. 2, January 7
9. DOE, 1993d, *INEL Stormwater Pollution Prevention Plan for Construction Activities*, DOE/ID-10425, February 19
10. DOE, 1994a, *Plan of Action to Resolve Spent Nuclear Fuel Vulnerabilities, Phase I*, Volumes I and II, U.S. Department of Energy, Washington D.C., February
11. DOE, 1994b, *Plan of Action to Resolve Spent Nuclear Fuel Vulnerabilities, Phase II*, U.S. Department of Energy, Washington D.C., February
12. DOE, 1994c, *Plan of Action to Resolve Spent Nuclear Fuel Vulnerabilities, Phase III*, U.S. Department of Energy, Washington D.C., February
13. DOE, 1995, *Department of Energy Programmatic Spent Nuclear Fuel Management and Idaho National Engineering Laboratory Environmental Restoration and Waste Management Programs Final Environmental Impact Statement*, DOE/EIS-0203-F, April
14. DOE, 1995a, *Record of Decision for the Department of Energy Programmatic Spent Nuclear Fuel Management and Idaho National Engineering Laboratory Environmental Restoration and Waste Management Programs Final Environmental Impact Statement*. May 30

15. DOE, 1995b, "Settlement Agreement" between the State of Idaho, Department of the Navy, and the Department of Energy, Oct. 16
16. DOE, 1995c, Order 420.1 "Facility Safety," November 16, 1995
17. DOE, 1995d, Order 441.1 "Radiological Protection for DOE Activities"
18. EPA, 1990, *The Clean Air Act Assessment Package - 1988 (CAP-88), A Dose and Risk Assessment Methodology for Radionuclide Emissions to Air*, Vol. 1, U.S. Environmental Protection Agency, Office of Radiation Programs, October 1990
19. Fischer, L. E., et al., 1987, *Shipping Container Response to Severe Highway and Railway Accident Conditions*, NUREG/CR-4829
20. Idaho Administrative Procedures Act (IDAPA), 1996a, "Rules for the Control of Air Pollution In Idaho," IDAPA 16.01.01.001 *et. seq*
21. Idaho Administrative Procedures Act (IDAPA), 1996b, " Wastewater Land Application Permit Rules," IDAPA 16.01.17.001 *et. seq*
22. Lacey, J., 1994, "Seismic Analysis of the Hot Shop Vestibule at TAN-607," EDF-TANO-94-24, EG&G Idaho, June
23. LITCO 1995a, *Idaho Chemical Processing Plant Safety Analysis Report Part I, Ch. 1* (INEL-94/022). March.
24. LITCO 1995b, *Performance Specification, ICPP Interim Storage System (ISS) Facility for the Long Term Storage of TMI-2 Fuel Project*, Rev 1, Project File No. 015239, May
25. Palmer, J. O., 1995. "Background on the Decision Not to Dry the TMI-2 Storage Canisters in Preparation for Interim Storage" LITCO, Letter No. AJP-02-95, Feb. 16
26. Peterson, H. K., 1991, Letter to S. K. Gray, EG&G "Reevaluation of the Dry Cask Storage Environmental Concerns" Letter No. HKP-11-91, Nov. 8
27. Reed, W. G., R. N. Holmer, B. L. Ringe, and J. W. Ross, 1986, *Archaeological Investigations on the INEL*, Idaho State University, Swanson/Crabtree Anthropological Research Laboratory, Report of Investigations 86-4
28. Reynolds, T. L., 1993, Memorandum to S. K. Gray, Subject: "Pool Stabilization Project" July 9
29. Ringe, B. L., 1993, Memorandum to S. K. Gray, Subject: "Dry Cask Storage Project," INEL Cultural Resources Office, EG&G Idaho, Inc., July 15
30. Rohrig, N. D., 1991, "TAN-607 Dose Estimates for Pool Draining Accident", EDF-WMTO-91-07, July
31. Staley, C.S., 1996, "Dose to Maximally Exposed Individuals due to Potential Airborne Releases from the INEL Storage of the TMI-2 Fuel Project," Engineering Design File EMA-96-001, LITCO, February

32. Thorne, D. to S. K. Gray, 1995. Memorandum, Subject: *"Assessment of the Potential Dose to INEL Workers from the Discharge of Tritiated Water in the TAN Pool to Disposal Ponds,"* April 9,
33. USFWS, 1995, Species List No. FWS 1-4-95-SP-225, File #506.0000, U.S. Fish and Wildlife Service, Sept. 22
34. Zohner, S. K., 1995 Letter to T. A. Solle, LITCO, *NESHAP Evaluation of TMI-2 Fuel Dewatering, Transportation and Dry Storage SKZ-05-95.* September 27
35. 10 CFR 20, Appendix A, "Protection Factors for Respirators," January 1987
36. 10 CFR 71, Section 55, "Packaging and Transportation of Radioactive Material, General Requirements for All Fissile Material Packages" 1991
37. 10 CFR 72, "Licensing Requirements for the Independent Storage of Nuclear Fuel and High-Level Radioactive Waste," 1991
38. 10 CFR 835, "Occupational Radiation Protection," 1993
39. 40 CFR 61, "National Emission Standards for Hazardous Air Pollutants," December
40. 40 CFR 260, "Hazardous Waste Management System: General"
41. 40 CFR 261, "Identification and Listing of Hazardous Wastes"
42. 40 CFR 262, "Standards Applicable to Generators of Hazardous Waste"
43. 40 CFR 263, "Transporters of Hazardous Waste"
44. 40 CFR 264, "Standards for Owners and Operators of Hazardous Waste Treatment, Storage and Disposal Facilities"
45. 40 CFR 265, "Interim Status Standards for Owners and Operators of Hazardous Waste Treatment, Storage and Disposal Facilities"
46. 40 CFR 268, "Land Disposal Restrictions," 1991
47. 40 CFR 122, "National Pollutant Discharge Elimination System," 1989

Appendix A

Responses to Comments

In accordance with the Department of Energy, Idaho Operations Office policy, the draft Environmental Assessment (EA) for the Test Area North Pool Stabilization Project was provided to the State of Idaho, the Shoshone-Bannock Tribes, and the public on February 20, 1995, for a 30-day public review and comment period. Following this public comment period, the EA was revised and on May 10, 1995 a draft EA and Finding of No Significant Impact (FONSI) was released for a 30-day public review and comment period. Following this second comment period, the EA and FONSI were revised in response to the comments and to incorporate information from the *Record of Decision for the Department of Energy Programmatic Spent Nuclear Fuel Management and Idaho National Engineering Laboratory Environmental Restoration and Waste Management Programs Final Environmental Impact Statement*. This appendix contains a summary of comments received on the draft EA and Department of Energy responses.

Appendix A

Responses to Comments

RESPONSES TO PUBLIC COMMENTS

Public Comment

Comment: Commentor asked why (nuclear) waste continues to be produced if there are problems finding places to put it.

Response: The purpose of the Test Area North (TAN) Pool Stabilization Project (PSP) Environmental Assessment (EA) is to evaluate the environmental impacts associated with the stabilization of the existing TAN Pool and its replacement with a passive, dry storage system to store these existing fuel and debris. The EA does not address production of new spent nuclear fuel or shipment of fuels to the INEL, and continued production and disposal of nuclear waste is outside the scope of this document.

RESPONSES TO STATE OF IDAHO'S COMMENTS

A. General Comment

1. Comment: The State of Idaho and the Snake River Alliance expressed concern over the level of NEPA analysis (EA vs EIS) for the proposed action.

Response: Appendix D to Subpart D of DOE's NEPA Implementing Procedures (10 CFR 1021) lists classes of actions that normally require an EIS. Item D10 of Appendix D to Subpart D lists the "Siting, construction, operation, and decommissioning of major treatment, storage and/or disposal facilities for high-level and/or spent nuclear fuel, such as spent fuel storage facilities and geologic repositories" as one of the classes of actions normally requiring an EIS.

The FEIS (DOE 1995) analyzes the cumulative environmental impacts of spent nuclear fuel management on the INEL including the consolidation of spent nuclear fuel at ICPP and the proposed TAN Pool Stabilization Project. The Record of Decision (ROD) for this FEIS makes a decision to consolidate spent fuels currently stored at various locations at the INEL at the ICPP as funding allows but deferred the decision on the TAN Pool Stabilization Project pending further project definition, funding priorities, or appropriate review under NEPA.

This EA was prepared to provide the further NEPA review identified in the ROD and address the site specific environmental impacts of the TAN Pool Stabilization Project. An EA is the appropriate level of NEPA review because neither the TAN Pool nor the proposed Interim Storage System at ICPP are major storage facilities within the meaning of DOE's NEPA Implementing Procedures. The meaning of the term "major" in the context of actions requiring EIS's is addressed in DOE's proposed amendment to the NEPA Implementing Procedures (61 FR 6414). Also, the analyses in this EA did not disclose any potential significant environmental impacts associated with the proposed action.

If DOE applies for NRC licensing of the ISS, an independent NEPA analysis would be conducted by the NRC for proposed actions conducted subject to their regulatory authority such as: a) the transportation of the spent nuclear fuel and debris to ICPP and b) the construction and operation of the ISS.

B. Specific Comments

1. Comment: The statement is made that miscellaneous hardware will be removed from the pool and disposed of in the RWMC. There are some "skeletons," fuel assembly hardware, in the pool that may be Greater Than Class C low level waste, which could not be disposed of at the RWMC. DOE needs to address this issue.

Response: Greater than Class C waste is a radioactive low level waste that exceeds the NRC concentration limits for Class C low level waste as specified in 10 CFR 61. The miscellaneous hardware, described in Section 2.1.1, is not fissile materials and is less than Class C waste. This hardware is LLW and meets the waste acceptance criteria for disposal at RWMC.

2. Comment: The statement is made that future programmatic missions have not been identified for TAN. Why, then is DOE proposing to store fuel at TAN?

Response: Section 1.0 has been revised to eliminate the storage of SNF at TAN as an alternative and Section 2.2.2.4 has been added to identify that storage of SNF at TAN would not be consistent with the FEIS Record of Decision (DOE 1995f). This revision to the EA is consistent with the decision in the ROD to consolidate the INEL SNF at ICPP.

3. Comment: The statement is made that the Storage Pool poses a minimal threat to human health and the environment. This seems to contradict the Preferred Alternative and support the No Action Alternative. What is the justification for the Preferred Alternative?

Response: Section 1.1 has been revised to clarify the need for action and the "Preferred Alternative" has been replaced with the "Proposed Action." It is DOE's intent to comply with the Settlement Agreement between the State of Idaho, Department of Energy, and the Navy, which states at Paragraph E7:

"DOE shall complete construction of the Three Mile Island dry storage facility by December 31, 1998. DOE shall commence moving fuel into the facility by March 31, 1999, and shall complete moving fuel into the facility by June 1, 2001."

This issue was negotiated to correct vulnerabilities previously identified at the TAN facility.

4. Comment: The statement is made that DOE-HQ signed an Action Description Memorandum (ADM) on May 26, 1993 stating that an EA would be the appropriate level of NEPA documentation. At that time, the plan was to place the TMI debris in Dry Casks and all fuel from the pool was to be stored on a pad at TAN. The change in project description has affected the appropriate level of NEPA documentation.

Response: See Response A(1).

5. Comment: The statement is made that the TMI fuel must be stored in a vented condition. However, it is already stated in the EA that the volatile radionuclides have escaped from the fuel as a result of the meltdown. Generation of hydrogen and oxygen gases from residual water should be minimal as the containers will be dried with hot nitrogen. A better explanation of why venting is required should be supplied.

Response: Section 1.2 has been revised to discuss the condition of the damaged fuel and venting requirements. This EA has also been rewritten to delete the option of drying the canisters. See Section 2.2.2.6.

6. Comment: The statement is made that the ISS would provide retrievability of the canisters to a spare position in the ISS or to a transfer cask that could interface with other ICPP fuel handling equipment. DOE needs to explain why this is required.

Response: Retrievability is an NRC requirement (10 CFR 72.122) that mandates that an ISS be designed to allow ready retrieval of spent fuel for further processing or disposal. Section 2.1.3 has been revised to identify this NRC requirement and rationale.

7. Comment: The statement is made that there are several types of ISS facilities available that could be modified to accommodate the TMI core debris and provides some description of them. DOE needs to provide more specific detail for the decisionmaker and the public to evaluate this issue.

Response: Figures 5 through 10 have been added to the EA to identify various existing commercial dry SNF storage systems that could be available. Any existing design would require modifications to accommodate the unique requirements of the TMI core debris. The extent of modifications required is not known at this time, since procurement of a storage system has not yet occurred. The environmental impacts of these different hypothetical designs do not differ from one design to the next.

8. Comment: "The ISS facility would be sized to accommodate 344 TMI canisters with a minimum of 5 spare storage positions for recovery purposes and would include space for appropriate support functions." From this statement the questions have to be addressed: what is the maximum storage capacity of this new facility; what is the cost; and, what other fuel types could be stored there?

Response: Retrievability is an NRC requirement for SNF storage systems. Many storage facilities are preconstructed modular units with a specific number of storage units (cells) per module. It is reasonable to assume that use of a modular type facility would result in a few (5 to 10) additional cells or storage positions. The estimated range of costs for the facility is 10 to 20 million dollars. The ISS design is specific to the TMI debris and commercial fuel stored in the TAN Pool. Any potential future expansion of this ISS would be required to be in compliance with the Settlement Agreement (DOE 1995b) and the February 28, 1996 Amended Record of Decision for the FEIS (DOE 1995).

9. Comment: Why is this DOE's preferred alternative? There are no reasons given other than the following speculative statement on (page 31, Para. 1) "The LET&D and PEW facilities at ICPP are Resource Conservation and Recovery Act (RCRA)-regulated facilities and analysis of the pool water would determine whether the water would meet the waste acceptance criteria for these facilities."

An explanation of why DOE prefers this alternative must be given when the following statements make it clear that the preferred alternative would not afford a higher degree of environmental protection: (Page 31, Section 4.1.2.3 Para. 2) "There is currently no defined DOE policy regarding de minimis quantities of radionuclides that can be discharged into the TAN TSF-07 sanitary and industrial wastewater pond or other radionuclide discharges to the soil column at the INEL." - "Because there is no treatment technology for tritium, the tritium concentration in the treated water would be equivalent to the concentration before treatment."

Response: Any of the identified treatment systems for the Storage Pool water would treat the water to meet the State and Federal requirements applicable at the time of treatment, currently projected to occur in 2001. The preferred option would not involve transportation of nearly 780,000 gallons of water to ICPP. It is anticipated that the release criteria applicable at the time of treatment can be met by the preferred treatment alternative. No treatment technology is capable of removing tritium since tritiated water is simply water with 2 additional protons on the hydrogen atom (H^3) and is, consequently, released by evaporation or volatilization.

10. Comment: The statement is made that the unfueled upper core support structures will be removed from the LOFT fuel. What will happen to these support structures? Are they Greater Than Class C waste? If so, they cannot be disposed of in the RWMC. On page 31, it says this waste would be considered low level waste. DOE needs to address the characterization of this waste stream in more detail.

Response: Section 2.1.1 has been modified to identify that the LOFT upper support structure may be disposed of at RWMC as LLW. These support structures are not fissile material, and are less than Class C waste.

11. Comment: Why isn't CPP-666 considered as a possible storage location for the TMI, LOFT and commercial fuels?

Response: CPP-666 is proposed to undergo a fuel storage rack reconfiguration to provide storage capacity for the fuels identified in the FEIS.

12. Comment: The statement is made that even though CPP-749 contains 14 wells specifically designed for the LOFT fuel, the drainage, monitoring and shielding is inadequate. A better explanation is needed as to why 14 wells specifically built for this fuel are inadequate. The potential to upgrade this facility should be addressed. Further, what is the status of the monitoring system for the fuel currently stored at CPP-749?

Response: The sentence in question was removed from the EA and language was added to Section 2.2.2.3 to clarify why the CPP-749 dry wells were not considered further. Upon review of this statement, DOE determined it was not accurate as the CPP-749 wells were designed as a generic underground storage system that can accommodate numerous fuel types (including LOFT fuel) and provide adequate monitoring, shielding, draining and venting capacity. This alternative was dismissed from further evaluation because other ICPP and TRA fuels have been identified for storage in the wells.

13. Comment: The statement is made that storage in the IFSF would be unsafe because the TMI canisters would extend 18 inches above the IFSF canisters. What modifications would be necessary for the IFSF to accept the TMI canisters? It seems appropriate to discuss whether modifications can be made before rejecting storage at IFSF.

Response: Section 2.2.2.3 was revised to address the rationale for rejecting this alternative.

14. Comment: The statement is made that the preferred alternative for treating the pool water is ion exchange or some other suitable treatment system. This statement is followed a short time later by statements that prior to draining the pool, the water would be analyzed and testing would be conducted to determine the appropriate treatment process. Hasn't at least some of this analysis and testing already been done?

Response: This sentence in Section 2.1.4 has been modified to clarify the intent of the paragraph. The water is tested on a regular basis. However, during the canister transfers and dewatering activities, the water would be churned and changes in the pool water concentrations could occur. Following water treatment, sampling of the treated water would also be conducted to ensure that the treatment system meets the discharge requirements.

15. Comment: Would there be no release of gaseous or particulate fission products from the dewatering (as opposed to drying) process, even though the drying process would be bounding?

Response: Releases from dewatered canisters would occur and the releases have been discussed in the EA in section 4.1.2.1. This section has been rewritten to address current ISS design information. The estimated doses for the proposed action of dewatering are well below the NESHAP limit of 10 mrem/yr.

16. Comment: Modeled doses should probably be expressed as rem and person-rem, not rem/yr and person-rem/yr. Only a one year emission period is being modeled. Also, cancer risk should be compared to the average lifetime probability of cancer death of about 18 percent.

Response: This table discussed the maximum dose consequence from drying, an alternative that has been eliminated [see Response B(5)]. Table 3 now identifies the EDE to the maximally exposed individual (MEI) for the proposed action. Though only a one-year emission period is modeled, the doses are expressed as rem- and person-rem per year for consistency and comparison value throughout the EA. Average lifetime probabilities are not typically compared to risks to the (individual) MEI as the maximally exposed individual is not an average value, but an estimate of risk of health effects (i.e. fatal cancers) from one action such as an accident or a specific activity with a definitive life-span.

17. Comment: The statement: "Anticipated emissions of tritium (which has a half-life of 12.5 years) from the discharged water would result in doses that would cause no adverse health effects to the public and as evidenced by worker doses of less than two rem/yr in the pool area." [underline added]. The underlined portion of this sentence is unclear and misleading, since a previous sentence states that the tritium release rate from an evaporative system would be higher than from the present pool. If the rate is higher, then exposures to a worker adjacent to an evaporation pond would be higher than the rate experienced next to the indoor pool. In fact, if the exposure occurs on a hot day, the rate and therefore the dose may be considerably higher.

Response: Exposures to INEL workers from tritium releases from an evaporation pond such as TSF-07 were modeled and the results were added to this discussion in Section 4.1.2.1. Currently, releases from the storage pool area result in worker doses of less than 2 rem/yr. The modeled dose for a worker standing next to an uncovered, unlined pond is below this value and below the DOE worker dose limit.

18. Comment: The statement is made that an individual would have to stand next to a loaded dry storage cask for 28 years to receive a 1 rem dose from neutrons. It is unclear why the analysis includes a discussion of neutrons, since this source of radiation is insignificant. As stated later in the same paragraph, greater than 97% of the radiation field around the outside of the cask would be from Cs-137 which is a gamma emitter.

Response: The paragraph was revised to reflect that the majority of the dose rate on the outside of the cask is due to Cs-137. The doses due to neutron emissions are insignificant, do not affect the outcome of the impact evaluation and were, therefore, deleted from the discussion in Section 4.1.2.2.

19. Comment: "The highest latent cancer fatality from potential accidents would result from the nitrogen gas line rupture accident"... is unclear. Presumably, "The highest probability of cancer fatality to the MEI..." is intended.

Response: The EA has been revised to delete canister drying as an alternative [see response B(5)]. As a gas-line rupture was associated with drying, the accident scenario associated with the use of nitrogen has also been eliminated. In addition, the highest probability of cancer fatality to the MEI is now from the commercial fuel assembly drop and the language in the EA has been revised.

20. Comment: How can the "Total effective dose equivalent (rem)" for the "Onsite worker at 300 m of 8.4E-05" be so much smaller than the "Maximally exposed individual at 1.1E+00." Wouldn't the workers receive more of a dose than offsite individuals?

Response: The MEI dose is higher because the release would be from the 45 ft TAN stack. Due to wind direction and speed, and other parameters, the worker at 300 m would potentially receive a lower dose.

21. Comment: Why is the dose (and corresponding cancer risk) to the MEI from the fuel assembly drop higher by a factor of about 10,000 than the dose to the onsite worker at 300 m, while for the other accidents the dose to the MEI is lower by a factor of about 1/2? Is an ingestion pathway being considered for this accident that leads to a higher MEI dose, or is this simply a typographical or transcription error? Note that this result is also inconsistent with the statement on p. 34, para. 5 quoted above.

Response: Table 5 has been revised to identify the exposure pathways. The fuel assembly drop gives no inhalation dose, therefore the ingestion pathway becomes a larger player in the total dose than a canister drop accident and worker exposures are proportionally much smaller (due to no ingestion). In addition, a different source term was used for each accident scenario as identified in Table 4 of the EA. The source term for the fuel assembly drop is very different than for the other accidents. C-14, which is present in the fuel assembly drop source term, but not the canister drop accident scenario, adds a significant amount of ingestion potential for the MEI. For the canister drop, ingestion accounts for approximately 70% of the dose. Consequently, dividing the MEI dose (which includes ingestion) by a very low worker dose (300-m, no ingestion), results in the large ratio presented in the comment above.

22. Comment: The statement is made that exposures along the south side of the pool were not analyzed for an accident that drains the pool as there is no access and the Hot Shop walls provide shielding in that direction. Based on the facility description and diagram in this EA, if the pool were to drain, the pool vestibule would also and radiation could enter the Hot Shop through the normally submerged passage way between them.

Response: This comment is correct. Section 4.2 has been revised to clarify the statement and identify the administrative controls that are in place to ensure workers leave the Hot Shop if an incident were to occur.

Appendix B

Siting Analysis Summary for the TMI Debris and Commercial Fuel Interim Storage System

Appendix B

Siting Analysis Summary for the TMI Debris and Commercial Fuel Interim Storage System

1. PURPOSE

This appendix summarizes the analysis conducted for the storage of the Three Mile Island (TMI) core debris, fuel assemblies from Loss-of-Fluid-Tests (LOFT), and government-owned commercial fuel rods and assemblies. The LOFT and government-owned commercial fuel rods and assemblies are hereafter referred to collectively as "commercial fuels". The preferred method of storage of these materials, as identified in the *Test Area North Pool Stabilization Project Environmental Assessment* (EA) (DOE 1995a), is dry storage in an interim storage system (ISS). The ISS would provide for the safe, reliable, and efficient management of this fuel until retrieved for ultimate disposal at a location outside the State of Idaho. As identified in the *Department of Energy Programmatic Spent Nuclear Fuel Management and Idaho National Engineering Laboratory Environmental Restoration and Waste Management Programs Final Environmental Impact Statement* (FEIS) (DOE 1995) Record of Decision (ROD), spent nuclear fuel located at the INEL would be sited at the Idaho Chemical Processing Plant (ICPP). Also included in this document is a summary of the analysis conducted to respond to the Tri-Party Settlement Agreement and the identification of future analysis to be conducted for Nuclear Regulatory Commission (NRC) licensing.

2. ALTERNATIVES ANALYSIS PROCESS

The range of reasonable alternatives for the location and method of storage for the TMI core debris and commercial fuels was identified by DOE-ID with input from DOE-HQ and the INEL management and operations contractors, WINCO, EG&G, and their successor, LITCO. The FEIS ROD provided direction for consolidation of INEL spent nuclear fuel at the Idaho Chemical Processing Plant (ICPP). Input was also solicited from the public through the DOE-ID NEPA process during the preparation of the EA. The EA's proposed action is to construct an ISS at ICPP. Storage alternatives that were not reasonable and dismissed are also identified in the EA.

The site selection and methods of storage were identified based on an evaluation of information including: special requirements associated with the debris storage; the need to consolidate spent nuclear fuel to minimize environmental, safety, and health (ES&H) vulnerability issues (WINCO 1994); dry storage providing a safe method of storage for spent fuel and special nuclear materials; and facility and natural resource analysis. Physical and natural resources such as hydrology, floodplains, slope, seismic risks, and threatened and endangered species were analyzed. The availability and proximity to infrastructure, facility security needs, land use compatibility, existing storage locations, and condition, lifespan, and future mission of existing facilities were also factored into the identification of storage options and locations.

The FEIS identified the Test Area North Pool Stabilization Project as one of the "ongoing projects" (Section C-2.1 of Volume 2, Part B of DOE 1995). The project's impacts were evaluated in the FEIS as part of the Alternatives A (no action), B (Ten-Year Plan), and D (Maximum Treatment, Storage, and Disposal). Based on the FEIS analysis, the ROD signed on May 30, 1995, identified actions that will occur at the INEL including a statement that "new dry storage capacity will be constructed and phased in" and "spent fuels currently stored at various locations at the Idaho National Engineering Laboratory will be

consolidated at the Idaho Chemical Processing Plant facilities as funding allows.” Specific action on the TMI fuel was identified in the ROD Appendix that stated “A new dry storage system for the storage of Three Mile Island fuel currently stored in an aging facility at Test Area North will be constructed upon receipt of any required approvals by the Nuclear Regulatory Commission.” The ROD appendix noted that this project is also the subject of an environmental assessment and that the “facility construction and operation were included in the cumulative impacts analyzed in the Environmental Impact Statement.”

2.1 Summary of Considerations for the Preferred Storage Method and Location

This section summarizes the siting analysis for the ISS at ICPP. The site, identified in Figure 4 of the EA, was selected based on an analysis of available sites at the ICPP facility. The ICPP site has existing ancillary services that facilitate dry fuel storage and management. These include a fenced (and restricted) exterior service boundary; emergency and security services; infrastructure including electricity, sewer, water, and stormwater systems; an internal transportation system of roads that connect to the INEL collector and arterial transportation system; and a rail access that could be used for loading and transporting the TMI debris and commercial fuels from the INEL to the final disposal site, when available. A summary of the evaluation of impacts to human health and the environment associated with ISS storage at the identified ICPP site follows:

Land Use: There would be minimal adverse impact to land use as a result of this action (Volume 1, Appendix B, Section 5.2 of DOE 1995). The proposed site for the dry storage of the TMI core debris and commercial fuels is less than 1 acre within the existing fenced area at the ICPP. This area is already dedicated to industrial use and has been previously disturbed by ICPP activities. The use of this land for spent nuclear fuel and debris storage is compatible with adjacent land uses which include the fuel receipt and storage areas (to the west and south) and the technical and operations support uses (to the east and north).

Expansion Capability: The ISS site has sufficient area for potential expansion (approximately 4 acres) that would be available for consolidation of spent fuel currently at the INEL.

Access: Construction of the ISS is proposed as a turn-key construction project where the contractor is responsible for design, construction, testing, and readiness review of the ISS prior to turnover to DOE-ID. A turn-key project requires that the contractor has control of the construction area with minimal access restrictions. This enables construction to proceed in an expedient manner with the contractor having control (with associated responsibility and liability) of activities at the construction site. At ICPP, this requirement may be met by selecting a site that has direct access to the external fence, can be fenced from the remainder of the facility, and does not interfere or conflict with the internal transportation system including emergency ingress or egress routes. The selected site meets this criterion.

Transportation: Shipping casks and the method of transport from TAN to ICPP will comply with applicable NRC and Department of Transportation requirements. Based on the transportation requirements, there are no reasonably foreseeable accident scenarios that would cause a threat to the public or environment from a radiological release from the casks (Section 4.1.3.2 of DOE 1995a).

RCRA, CERCLA, Radiological or Utility Restrictions: This site is not a RCRA, CERCLA or radiologically controlled area (Ferguson et al, 1994). The construction site does not have underground or overhead utilities that would be impacted or require moving. Site approval has been received from the Lockheed Idaho Technologies Company (LITCO) Facility Planning Committee and designated Siting Coordinators (Mickelson 1995).

Risks to Human Health and Environment: As documented by the FEIS bounding accident analyses (Volume 1, Appendix B, Section 5.15 of DOE 1995) and project specific analyses in the EA (Section 4.1.3 of DOE 1995a), there are no significant risks to human health or the environment associated with transportation or storage of the TMI debris or commercial fuel at the INEL. In addition, in review of the *Idaho Chemical Processing Plant Safety Analysis Report* (LITCO 1995), the site is not restricted by safety zones or setback standards based on potential accident scenarios for existing buildings and uses at ICPP (Baranick, 1996).

Socioeconomics: Construction of this dry storage ISS at the ICPP would cause a short-term increase in the temporary construction force at the INEL. This increase would be within the normal workforce fluctuations. Construction and operation of this ISS would not cause any long-term changes in employment, population, housing, or community services. It is anticipated that existing INEL personnel with expertise and training in the management of stored spent nuclear fuel would manage this ISS. As fuel handling personnel are already employed at the ICPP, the siting of additional storage capacity within the ISS could provide for an efficiency of personnel, support buildings, training, and equipment. There would be no adverse socioeconomic impacts resulting from the activity (Section 4.1.2.4 and 4.1.4 of DOE 1995a; Volume 1, Appendix B, Section 5.3 and 5.16.2 of DOE 1995).

Cultural and Paleontological Resources: The site is located within the fenced area at ICPP and has been extensively disturbed from previous activities. All areas within the ICPP facility perimeter have been surveyed for historical and archeological resources and, based on a cultural resource review for this project, would not be impacted (Section 4.1.1 of DOE 1995a; Volume 1, Appendix B, Section 5.4 and 5.16.3 of DOE 1995). If excavation activities expose any unusual materials (e.g., bones, fossils, obsidian flakes, darkly stained soil horizons) construction activities would cease immediately, resuming only after professional cultural or paleontological resource specialists are consulted and any necessary mitigative action completed.

Aesthetic and Scenic Resources: Due to the siting of this ISS in an existing developed area and the distance from public access points (greater than 2 miles), there would be no adverse consequences to aesthetic and scenic resources (Volume 1, Appendix B, Section 5.5 of DOE 1995). Although the construction would produce fugitive dust that could temporarily affect visibility, standard construction practice to minimize both erosion and dust generation would be followed. ISS operation would not cause a degradation of the air quality standards that would impact the Class I air quality standards for the Craters of the Moon National Monument wilderness area.

Geology and Soils: Impacts to geologic resources would be associated with the excavation into soil and subsurface at the site, soil mounding and banking, and the extraction of aggregate from site gravel pits for base and fill material. Based on the limited area of excavation and volume of fill material required for the project, there would be no adverse impact to the geological resources. A secondary impact to geological resources from construction activities would be the potential for increased soil erosion. The project would minimize any potential soil erosion by the use of a stormwater pollution prevention plan to control stormwater runoff, slope stability, and provide for site revegetation so as to cause no adverse impact to geological resources (Section 4.1.1 of DOE 1995a; Volume 1, Appendix B, Section 5.6 of DOE 1995).

Air Quality: There would be no adverse impacts to air quality as the project would comply with the Clean Air Act which contains requirements to prevent the deterioration of air quality from radiological and non-radiological emissions (Section 4.1.2.1 and 4.1.4 of DOE 1995a; Volume 1, Appendix B, Section 5.7 and 5.16.4 of DOE 1995). Potential short-term impacts to nonradiological air quality would include fugitive dust and exhaust emissions from support equipment during construction that would be temporary and localized. These short-term impacts would be reduced by following standard construction practices to minimize dust generation through the use of watering and dust surfactants. Long-term impacts would be evaluated as part

of a permit to construct (PTC) evaluation. This evaluation would identify the applicable requirements of the Clean Air Act and ensure that any required permits and approvals would be obtained prior to construction.

There would be no adverse impacts due to radiological emissions from the fuel debris and commercial fuel during storage at the ICPP. On an INEL-wide basis, there would be no increase in emissions, only a change in the location of emissions from the current location at TAN to ICPP. The modeled effective dose equivalent (EDE) of emissions from the fuel and debris is below the National Emission Standards for Hazardous Air Pollutants (NESHAPs) standard of 1% of the 10 mrem/yr standard (.1 mrem/yr) and NESHAPs approval is not required (Zohner, 1995).

Water Usage: During construction, there would be increased water use associated with dust suppression and general construction activities. This water would be supplied from the existing ICPP water system and the short-term usage would not adversely impact the capability of the water system or wells. When constructed, the ISS would not be connected to the water system. Therefore, no long-term impact on water usage is anticipated as a result of the operation of this ISS (Volume 1, Appendix B, Section 5.8 of DOE 1995, Section 4.1.1 of DOE 1995a).

100 and 300 Year Floodplains and Wetlands: There are no wetlands or 100 year floodplains located within the ICPP (Ferguson, et al. 1994) that would be impacted by the project (Volume 1, Appendix B, Section 5.9 of DOE 1995). The combination of local climate, relief, and geology provides the INEL with good natural flood-regulating characteristics. The Big Lost River is the only drainage to the INEL that provides any real flood threat to the ICPP. A flood diversion system near RWMC, constructed in 1958 and enlarged in 1984, protects INEL facilities such as ICPP from floods by diverting the floodwater to a basin that provides floodwater storage and infiltration. Based on an evaluation of the balance of storage and infiltration, the flood diversion system has the capability to accommodate the flood crest from the postulated 300-year flood [Section 1.4.5.2.4 of LITCO 1995]. The diversion system, therefore, is considered to provide adequate flood protection to the ICPP (Section 1.4.5.2.6 of LITCO 1995) and the proposed ISS site. There are no siting limitations at the ICPP based on the 300 year floodplain; thus, the ISS is not anticipated to be affected.

Maximum Probable Flood (MPF): The impact to the ICPP of a maximum probable flood (MPF) was analyzed to provide a conservative flooding condition. The MPF is considered conservative as the last flood of the magnitude of an MPF occurred about 12,000 years ago during a wet climate cycle. The MPF scenario has flows estimated at 991.2 m³/s (35,000 cfs) with a water velocity that would range from 0.18 to 0.91 meters per second (0.6 to 3.0 feet per second) on the INEL. This flood would result in shallow, slow-moving flood water within the ICPP-controlled area up to an elevation of 1498.7 m (4916.6 ft). Based on elevations at ICPP, facilities that are in the northern half of the ICPP area would have approximately one to two feet of water while the southern end of ICPP would be above the MPF floodplain (Figure 1.4-57 of LITCO 1995).

The MPF velocities and water depth would have minimal impact on an ISS due to its design to withstand flooding. All INEL facilities are designed to meet the INEL architectural and engineering standards that establish design criteria to protect new facilities from adverse impacts associated with a MPF. Methods of flood protection (including MPF protection) include adding fill material to elevate structures; placing the contents above the flood elevation; designing the structure and the contents to protect against structural failure, to keep water out, or to reduce the effects of water entry. These methods would be employed in the design of the ISS. It is noted that an updated floodplain map of the Big Lost River floodplain is being prepared that will map the 100 and 500 year floodplains. Pending completion of the updated floodplain map (expected to be available in 1997), it is assumed that the area encompassed by the MPF is greater than that for the 100 year and 500 year floods. As discussed previously, any potential impact to the ISS from a MPF would be mitigated as part of the design.

Ecology: There are no threatened or endangered species of animals or plants located within the ICPP facility perimeter that would be impacted by this project (Section 4.1.2.4 of DOE 1995a) and no long-term adverse impacts are anticipated (Volume 1, Appendix B, Section 5.9 of DOE 1995).

Seismic Hazards: Seismic hazards at the INEL include surface deformation (surface faulting, tilting) and ground shaking. Other potential seismic hazards (e.g., avalanches, landslides, mudslides, soil settlement, and soil liquefaction) are not likely to occur at the INEL because the local geologic conditions are not conducive to them (Section 4.6.3, Volume 2, Part A, DOE 1995). The magnitude and frequency of these potential seismic events and their surface accelerations at the INEL have been quantitatively described in deterministic and probabilistic seismic hazard assessments for the ICPP and other INEL facilities. This information and any ongoing INEL seismic analysis would be used to assess the INEL seismic hazards for the NRC evaluation. To ensure that the ISS is constructed to withstand seismic hazards, the ISS would be designed to meet the NRC seismic requirements of 10 CFR 72 "Licensing Requirements for the Independent Storage of Spent Nuclear Fuel and High-level Radioactive Waste."

4. OFF-AQUIFER SITING ANALYSIS

Additional evaluations for dry storage of the TMI material have been conducted in response to the tri-party (settlement) agreement between the State of Idaho, the Navy and the U.S. DOE signed on October 17, 1995. An analysis (Moriarty, 1995) was conducted to determine the feasibility of locating dry storage of spent nuclear fuel on INEL land at a site that is not over the Snake River Plain Aquifer (SRPA). The study identified two potential sites at the INEL that were not over the SRPA. This analysis dismissed one site as it is a recharge area for the SRPA and is near a geologic fault that could be considered a potential seismic threat. The other site was dismissed due the parcel's proximity (1 mile) from a capable geological fault, steep slopes of the land or drainage to the SRPA, potential habitat for sensitive species, proximity to private land, and visibility from Highway 22. Dismissal of this parcel is supported by the May, 1995 report "*Spent Fuel Storage at the INEL Yet Off the Aquifer*" that reiterates the water recharge and seismic concerns associated with the parcel.

5. FUTURE NEPA AND SAFETY ANALYSES

DOE plans to proceed with Nuclear Regulatory Commission (NRC) licensing of the ISS. NRC licensing requirements include additional NEPA and safety analysis of the location and the method of storage as part of the NRC licensing review process (10 CFR §§51 and 72). These analyses will ensure that the ISS is designed and sited so as to not provide undue risk to the health and safety of the public and environment. NRC review includes consideration of the frequency and severity of external natural along with man-induced events that could affect the safe operation of the ISS (10 CFR §§ 72.90).

NRC review requires that consideration be given to the present and future character and distribution of population, land and water uses, and potential consequences of a release of radioactive material (10 CFR §§72.98 and 72.100). The ISS will be evaluated for seismicity (10 CFR §§72.102) for a design basis earthquake including impacts associated with the maximum vibratory ground acceleration, soil instability due to ground disruption, and seismically induced floods. When the specific requirements related to the site characteristics and method of storage that may directly affect public health or the environment are assessed by the NRC and determined to conform to the requirements, NRC will issue a license to construct the ISS. Continued operation of the licensed ISS will require ongoing NRC compliance and inspections.

6. SUMMARY

DOE has identified and analyzed the impacts associated with the storage of the TMI debris and commercial fuels. The preferred alternative, as identified in the *Test Area North Pool Stabilization Project EA*, is dry storage in an ISS at ICPP. Based on a thorough analysis of the impacts associated with the ISS siting and operation at ICPP, it has been identified that there would be minimal adverse impacts associated with the action (DOE 1995a, DOE 1995). This has been supplemented with further analyses concerning the feasibility of siting a storage site at the INEL that is off the Snake River Plain Aquifer. This evaluation determined that locations that are off the aquifer are not suitable storage sites, further supporting the EA analysis. DOE plans to proceed with NRC licensing of the ISS. This will result in additional NEPA and safety analysis by the NRC of the location and method of storage as part of the licensing requirements. This analysis will ensure that the ISS is designed and sited to protect the health and safety of the public and environment. Continued operation of the licensed ISS under ongoing NRC compliance and inspections will ensure that this protection is maintained.

7. REFERENCES

- Baranick, J. O., 1996 Letter to J. O. Carlson, LITCO, *ICPP High Consequence Accidents* (GDP-01-96). Feb. 12
- DOE 1995 *Department of Energy Programmatic Spent Nuclear Fuel Management and Idaho National Engineering Laboratory Environmental Restoration and Waste Management Programs Final Environmental Impact Statement* April.
- DOE 1995a *Test Area North Pool Stabilization Project Environmental Assessment* (DOE/EA-1050). May.
- Ferguson, F. G., J. Andrews, 1994 *Idaho Chemical Processing Plant Technical Site Information*. WINCO-1200. March.
- LITCO 1995 *Idaho Chemical Processing Plant Safety Analysis Report Part I, Ch. 1* (INEL-94/022). March.
- Mickelson, W.A., 1995 Letter to J. O. Carlson, LITCO, *ICPP Siting Request* WAM-02-95. Jan. 23.
- Moriarty, T. P., 1995 Letter to M. R. Arenaz, DOE-ID, *Feasibility of Locating Dry Storage of Spent Nuclear Fuel on Idaho National Engineering Laboratory (INEL) Land at a Site That Does Not Overlie the Snake River Plain Aquifer (SRPA)*, Nov. 15.
- WINCO 1994 *INEL Integrated Spent Nuclear Fuel Consolidation Task Team Report* (WINCO-1217) Sept. 12.
- Zohner, S. K., 1995 Letter to T. A. Solle, LITCO *NESHAP Evaluation of TMI-2 Fuel Dewatering, Transportation and Dry Storage* SKZ-05-95. Sept. 27.