

4-17

SANDIA REPORT

SAND96-0923 • UC-704

Unlimited Release

Printed April 1996

RECEIVED

MAY 15 1996

OSTI

Ceramic Powder Synthesis in Supercritical Fluids

C. L. J. Adkins, E. M. Russick, J. Cesarano, M. E. Tadros, J. A. Voigt

Prepared by
Sandia National Laboratories
Albuquerque, New Mexico 87185 and Livermore, California 94550
for the United States Department of Energy
under Contract DE-AC04-94AL85000

Approved for public release; distribution is unlimited.



SF2900Q(8-81)

DISTRIBUTION OF THIS DOCUMENT IS UNLIMITED

MASTER

Issued by Sandia National Laboratories, operated for the United States Department of Energy by Sandia Corporation.

NOTICE: This report was prepared as an account of work sponsored by an agency of the United States Government. Neither the United States Government nor any agency thereof, nor any of their employees, nor any of their contractors, subcontractors, or their employees, makes any warranty, express or implied, or assumes any legal liability or responsibility for the accuracy, completeness, or usefulness of any information, apparatus, product, or process disclosed, or represents that its use would not infringe privately owned rights. Reference herein to any specific commercial product, process, or service by trade name, trademark, manufacturer, or otherwise, does not necessarily constitute or imply its endorsement, recommendation, or favoring by the United States Government, any agency thereof or any of their contractors or subcontractors. The views and opinions expressed herein do not necessarily state or reflect those of the United States Government, any agency thereof or any of their contractors.

Printed in the United States of America. This report has been reproduced directly from the best available copy.

Available to DOE and DOE contractors from
Office of Scientific and Technical Information
PO Box 62
Oak Ridge, TN 37831

Prices available from (615) 576-8401, FTS 626-8401

Available to the public from
National Technical Information Service
US Department of Commerce
5285 Port Royal Rd
Springfield, VA 22161

NTIS price codes
Printed copy: A03
Microfiche copy: A01

Ceramic Powder Synthesis in Supercritical Fluids

C. L. J. Adkins and E. M. Russick
Organic Materials Processing

J. Cesarano and M. E. Tadros
Ceramic Processing Science

J. A. Voigt
Ceramic Synthesis and Inorganic Chemistry

Sandia National Laboratories
Albuquerque, NM 87185

Abstract

This report presents the results of a feasibility study performed in order to investigate the use of supercritical fluids to synthesize ceramics. Two approaches were taken. A small batch high pressure carbon dioxide reactor was built. In this reactor it was found that oxide ceramics can be synthesized in a supercritical carbon dioxide (SCCO₂) environment if surfactants are used to stabilize the reactants. The presence of the SCCO₂ soluble surfactant is critical to the process. A spherical, polydisperse (diameters ≤ 1 micron) titanium dioxide powder was synthesized in SCCO₂ using titanium isopropoxide and water. The advantages of working in carbon dioxide, versus supercritical water, include mild pressures and temperatures, a less corrosive environment, and, in general, a safer, simpler system. As an alternative approach, a continuous flow, high pressure water reactor was built. Temperature control and equipment maintenance on this system proved very difficult.

Intentionally left blank.

Contents

Introduction	1
Background	1
Synthesis of Titanium Dioxide Using the Reverse Micelle Technique	5
Experimental.....	5
Control Experiments.....	6
Results	9
Conclusions	12
Powder Synthesis in a Continuous Hydrothermal/Supercritical Reactor System	13
Equipment.....	14
Reactor/Flowrate Temperature Calibration	16
Boehmite.....	16
Conclusions	17
References	18

Figures

1	The Physical Processes by Which an Aerosol Forms and Grows by Thermal Decomposition/Reaction.....	3
2	Rapid Expansion of a Supercritical Fluid Through a Nozzle	3
3	Static CO ₂ Reverse Micelle Reactor	6
4	View Cell Apparatus for Solubility Measurements.....	7
5	Schematic of Reaction Medium	8
6	Silver Chloride Particles Prepared from Aqueous Solutions of AgNO ₃ and NaCl with Zonyl FSJ Surfactant	8
7	SEM of Titanium Dioxide Particles Prepared from Ti[OCH(CH ₃) ₂] ₄ , and an Aqueous Solution of Zonyl FSJ in SCCO ₂	9
8	X-ray Diffraction Pattern of Titanium Dioxide Powder Prepared Using Reverse Micelle Technique	10
9	TGA/DTA Results for Titanium Dioxide Powder Prepared in SCCO ₂	11
10	SEM of Titanium Dioxide Prepared by Hydrolysis of Ti[OCH(CH ₃) ₂] ₄ in a Mixture of Pentanol and Zonyl FSJ.....	11
11	SEM of Titanium Dioxide Particles Prepared from Ti[OCH ₂ CH(C ₂ H ₅)(CH ₂)CH ₃] ₄ and an Aqueous Solution of Zonyl FSJ in SCCO ₂	12
12	Continuous Hydrothermal/Supercritical Reactor System Schematic	14

Tables

1	Critical Properties of Common Fluids.....	2
2	Solubility Data for Metal Alkoxides at 40°C	13
3	Temperature-Flowrate Characteristics of the Flow Reactor System	17



Ceramic Powder Synthesis in Supercritical Fluids

Introduction

Today, gas-phase processing plays an important role in the commercial production of a number of ceramic powders.¹ These include titanium dioxide, carbon black, zinc oxide, and silicon dioxide. The total annual output of these materials is on the order of 2 million tons.¹ The physical processes involved in gas-phase synthesis are typical of those involved in solution-phase synthesis --- chemical reaction kinetics, mass transfer, nucleation, coagulation, and condensation.

Since the phenomena associated with ceramic processing begin with preparation of the starting powder, new techniques and methods for synthesizing high-purity, non-agglomerated, well-characterized, submicron powders having a narrow size distribution are constantly being sought. Indeed, advanced material synthesis and innovative aerosol processes have been singled out as areas requiring additional research in powder synthesis.² "Gas-phase" synthesis methods (non-liquid) offer a number of benefits in the production of ceramic powders. These are: (1) direct formation of the particulate --- calcining is not generally required as a separate step; (2) complex oxide formation is possible; (3) intimate mixing of the components; (4) high purity; (5) size distribution control; and (6) waste minimization. Perhaps the greatest disadvantages to gas-phase synthesis are the difficulty of the processes and their control, and lack of a full understanding of the relationship between the physical processes involved and their impact on the resulting product powder morphology.

This report will focus on the work done under a Laboratory-Directed Research and Development (LDRD) project that explored the use of various high pressure techniques for ceramic powder synthesis. Under this project, two approaches were taken. First, a continuous flow, high pressure water reactor was built and studied for powder synthesis. And second, a supercritical carbon dioxide static reactor, which was used in conjunction with surfactants, was built and used to generate oxide powders.

Background

A supercritical fluid is defined as a material above its critical temperature and critical pressure (see Table 1). Consequently, these fluids are not in the

"gas-phase", although they are characterized by "gas-like" transport properties and "liquid-like" densities. They also offer a greatly enhanced solvating capability when compared to gases. Recently, the use of supercritical fluids has been applied to the generation of ceramic powders.^{3,5} Reactions in the supercritical phase can lead to the nucleation of particles or the rapid expansion of a supercritical fluid can result in the particle formation.^{3,4} As the pressure is reduced, the solubility of the solute decreases and supersaturation occurs. Stable nuclei are formed and coagulation and condensation result in particle growth. The process is much like that which occurs in a vapor precursor/thermal decomposition particle formation process. The advantages of high pressure processes include: (1) waste minimization since the process fluid is recyclable; (2) submicron powder formation; and (3) "nonequilibrium" products as a result of the rapid particle formation in the rapid expansion technique. Disadvantages include: (1) the high pressure operation; and (2) a general lack of information and understanding about the behavior of supercritical fluids.

Table 1. Critical Properties of Common Fluids

Solvent	Critical Temperature (°C)	Critical Pressure (atm)
Ammonia	132.5	112.5
Carbon Dioxide	31	72
Ethanol	243	63
Isopropanol	235	47
Nitrous Oxide	36.5	71.7
Water	374.1	218.3

A schematic of a generic process whereby particles are nucleated under constant pressure conditions is presented in Figure 1. The sequence of events is similar whether particle formation occurs under atmospheric or high pressure conditions. The rapid expansion process is schematically described in Figure 2. The working fluid is compressed to a supercritical condition and flows to a vessel containing the bulk material that is to be dissolved. Solute-rich fluid flows to a collection chamber where it is allowed to expand through a nozzle. The gaseous working fluid passes out of the chamber. In the laboratory the gas is typically vented, although it could easily be recycled. The point at which particle formation actually occurs is still a subject of debate.

Matson et al.⁴ have used the rapid expansion technique to produce silica powders from supercritical water. The solubility of silica in water at 500°C and 1000 atm is 2600 ppm.³ It was found that the size of the product depended strongly on the silica concentration in the supercritical fluid prior to expansion.

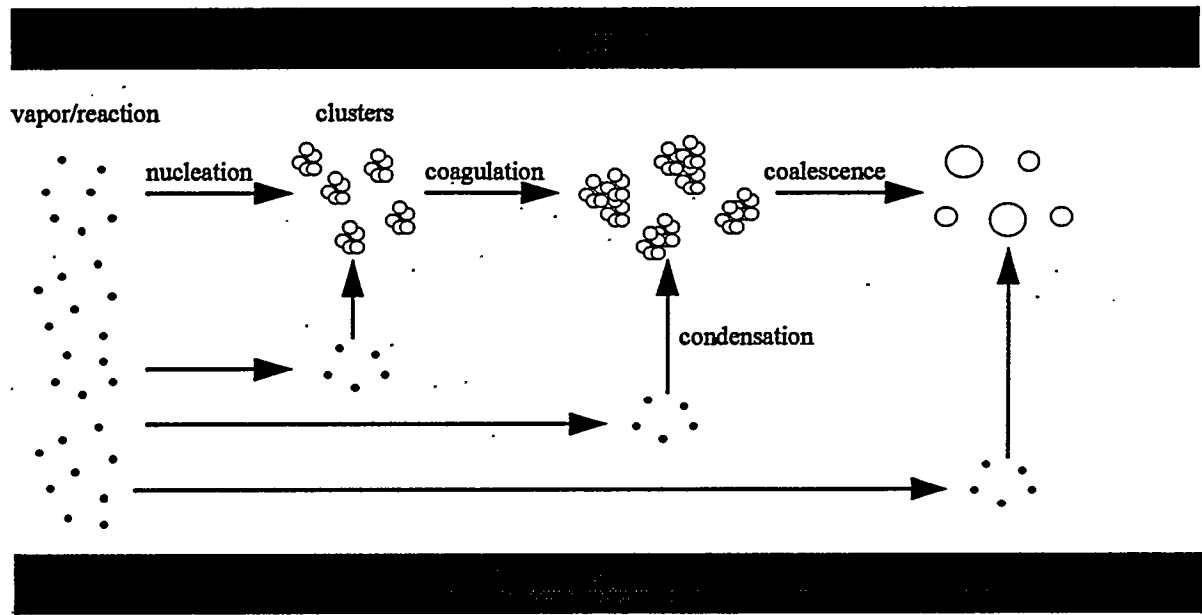

Figure 1. The Physical Processes by Which an Aerosol Forms and Grows by Thermal Decomposition/Reaction

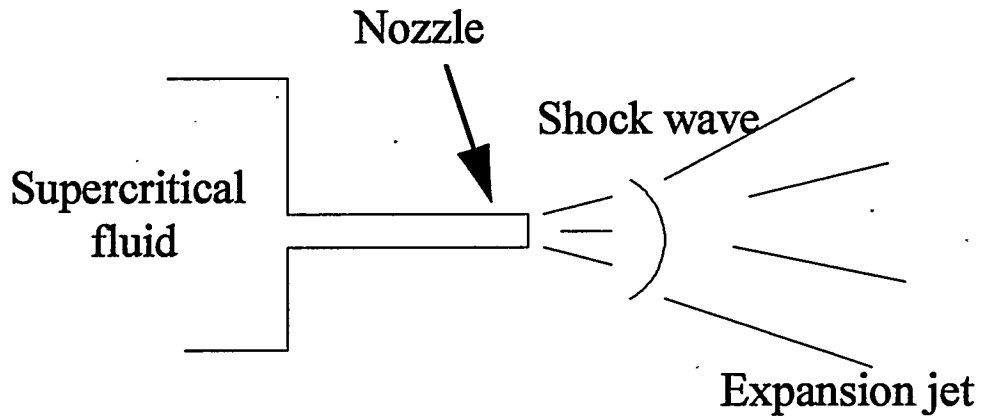

Figure 2. Rapid Expansion of a Supercritical Fluid

Particle sizes ranged from 0.1 to 0.5 μm in diameter. The morphology of the particles was found to depend on the nature of the expansion nozzle --- an orifice nozzle produced elongated particles while a capillary nozzle produced spheres. The difficulty with this particular process is that it is simply the regeneration of an already existing silica powder which is relatively insoluble in the working fluid. Germanium oxide (GeO_2) powder was also produced using a similar process.³

Pommier et al.⁵⁻⁷ produced spinel, MgAl_2O_4 , powders in supercritical ethanol. In this case, the supercritical fluid served as a reactive medium as opposed to merely a carrier fluid. A 0.1 M solution of the precursor material, $\text{Mg}(\text{Al}(\text{OR})_2)_4$ where R is a sec-butyl group, was charged into a high pressure reactor. The reactor was pressurized and heated. The vessel was then depressurized and the powders collected and dried. Primary particle sizes ranged from 0.04 to 0.2 μm , although due to agglomeration, the light scattering measurements indicated particle sizes on the order of several microns. Low levels of residual organic were detected after drying and the particles were approximately 10 to 30% crystalline. After annealing at 1000°C for an hour, complete crystallization was obtained. It is believed that simultaneous hydrolysis, polycondensation, and thermal decomposition reactions lead to powder formation.

In another investigation of high pressure ceramic synthesis, Adschiri et al.⁸ used metal salt -- nitrates, chlorides, etc. -- solutions as the metal oxide precursor materials. These solutions were fed to a continuous flow, high pressure water reactor where the temperature and pressure were increased to supercritical conditions. Hydrothermal crystallization of the powder occurred. The water-powder mixture was collected at the reactor outlet through the back-pressure regulator. Reactor residence time was on the order of two minutes. The oxides were formed via hydrolysis of the salt to produce metal hydrous oxide, followed by dehydration. Small particles (< 1 micron) were formed. The inherent disadvantage of this technique -- reaction followed by controlled pressure let-down -- is that a water slurry of the product is collected and must be filtered and dried.

Finally, it is possible to use the supercritical fluid as a carrier solvent which does not participate in the reaction, but merely disperses the reactants. A "fluid-philic" surfactant can be used to form reverse micelles in which a water-soluble reactant is dispersed in the supercritical fluid. A second reactant, soluble in the supercritical fluid, diffuses into the micelle and reacts. From a powder production standpoint, one of the advantages of this technique is that each micelle acts as an individual reactor which is diffusion-limited. High diffusion rates may reduce the powder polydispersity and the pressure dependence of the

fluid's behavior will facilitate particle separation. Also, the addition of surfactant allows the use of supercritical fluid's one does not expect to participate in the reactions. This technique was used by Matson et al.⁹ to form Al(OH)₃ particles in supercritical propane. A surfactant was used to generate reverse micelles containing aqueous aluminum nitrate. The Al(OH)₃ particles were precipitated upon the injection of ammonia. The mean particle size depended on the aluminum nitrate concentration in the micelles.

Synthesis of Titanium Dioxide Using the Reverse Micelle Technique

Supercritical carbon dioxide is an attractive medium for the synthesis of ceramic powders because it is nontoxic, nonflammable, has a low critical temperature, a high degree of compressibility, and low cost. However, the highly nonpolar character of CO₂ limits the solubility of polar materials.¹⁰ In order to use SCCO₂ as a reaction medium, it is necessary to use the reverse micelle technique described above. Hydrocarbon-based surfactants have limited solubility and are not useful for the stabilization of aqueous droplets in SCCO₂. Surfactants with low solubility parameter moieties such as fluorocarbon or dimethyl siloxane groups are more soluble in SCCO₂¹¹⁻¹⁴ and some of these surfactants have been shown to enable formation of reverse micelles and microemulsions in supercritical CO₂.^{12,13} The objective of this work is to investigate conditions for the synthesis of titanium dioxide particles from titanium alkoxides in supercritical CO₂.

Experimental

Reagent grade titanium alkoxides were used without further purification. Zonyl FSJ (Du Pont) is a water soluble fluorinated anionic surfactant with the general formula $(F(CF_2CF_2)_zCH_2CH_2O)_xP(O)(ONH_4)_y$, where $x = 1$ or 2 , $y = 1$ or 2 , and $z = 1-7$. This surfactant contains 15% isopropanol and 40% water. Aerosol-OT (Dow) is an anionic surfactant having the formula sodium bis(2-ethylhexyl) sulfosuccinate $(RO_2CCH_2CH(SO_3Na)CO_2R)$, $R = CH_2(CH_2)_3CH(C_2H_5)CH_2-$.

The reactions were performed in a 300 ml Parr high pressure cell fitted with three 2.4 cm thick sapphire windows at right angles. Two Pyrex glass containers were placed inside the reactor. The glass containers were sufficiently tall to ensure that the rim of the containers was higher than the top portion of the viewing windows as shown in Figure 3. This configuration ensured that the contents of the two glass containers did not mix with each other upon filling the reactor with liquid CO₂ to within the viewing level.

The general experimental procedure was as follows. The metal alkoxide was placed in one of the Pyrex containers and an aqueous solution of surfactant was placed in the other Pyrex container. The reactor was then flushed and filled with liquid CO₂ at 15°C to a level corresponding to the top portion of the viewing windows (~110 ml). The contents of the containers were each individually stirred by magnetic bars and a magnetic stirrer. The reactor was then heated to the desired temperature for a specified time, cooled to 20°C, vented, and opened. Particles were collected and examined by SEM, X-ray diffraction, and thermal analyses.

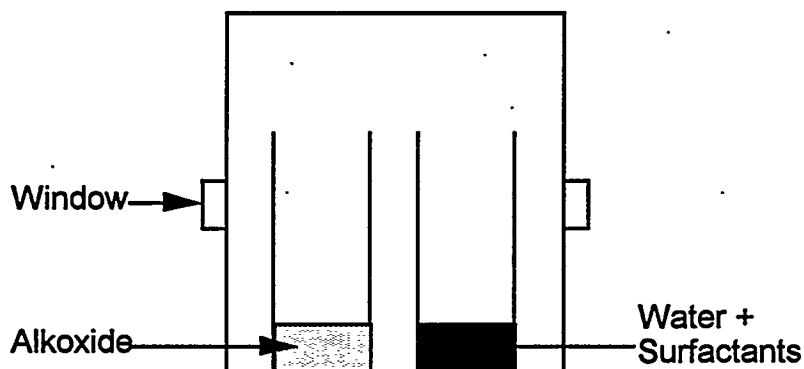

Figure 3. Static CO₂ Reverse Micelle Reactor

The solubility of various metal alkoxides in supercritical CO₂ was measured in a high pressure view cell. A schematic of this apparatus is shown in Figure 4. A high pressure "syringe" was used to vary the volume and pressure. A sapphire window allows viewing of the mixture by a fiber optic boroscope. The entire system was placed in a thermostated chamber. All solubility experiments were carried out at 40.0±0.1°C. Given amounts of an alkoxide and CO₂ were weighed into the cell which was then heated and stirred. The pressure was increased until a homogeneous phase was observed. The pressure was then decreased slowly until a "dew point" was observed, corresponding to conditions for phase separation of the alkoxide from the CO₂. This can be interpreted two ways. First, at 40°C and all pressures greater than the dew point, this amount of alkoxide is soluble in the SCCO₂. Or second, at 40°C and the dew point pressure, the alkoxide is soluble up to this concentration.

Control Experiments

In order to form a metal oxide in this apparatus, the following had to be true. First, the surfactant was soluble in SCCO₂. Second, the surfactant would form reverse micelles containing water in the SCCO₂. And third, the metal alkoxide was soluble in the SCCO₂ (see Figure 5). In order to verify the first and second points -- that the surfactant would stabilize an aqueous dispersion in SCCO₂ -- a series of control experiments were performed.

An aqueous solution of silver nitrate (AgNO_3) and a surfactant was placed in one of the glass containers and an aqueous solution of sodium chloride (NaCl) and the same surfactant was placed in the other. The reactor was charged with CO_2 and heated as usual. The results indicated that when no surfactant, or when Aerosol-OT was used, no AgCl precipitate was observed. Clearly, no mixing occurred between the solutions in the supercritical CO_2 phase under these conditions. However, when the fluorinated surfactant Zonyl FSJ was used, fine particles of AgCl were obtained (see Figure 6). Zonyl FSJ is soluble in CO_2 and carries the aqueous solutions into contact with each other. These particles are similar to particles prepared by the direct mixing of two microemulsion solutions, one containing AgNO_3 and the other containing NaCl .¹⁵ In the past, dyes have been used to ascertain the formation of stable micelles and microemulsions in supercritical fluids^{12,16}. The precipitation method adopted here is preferred over the dye solubility method because of the difficulties associated with observations through the reactor and potential interactions between the dye and carbonic acid, *e.g.*, thymol blue is bleached in the presence of CO_2 and water.

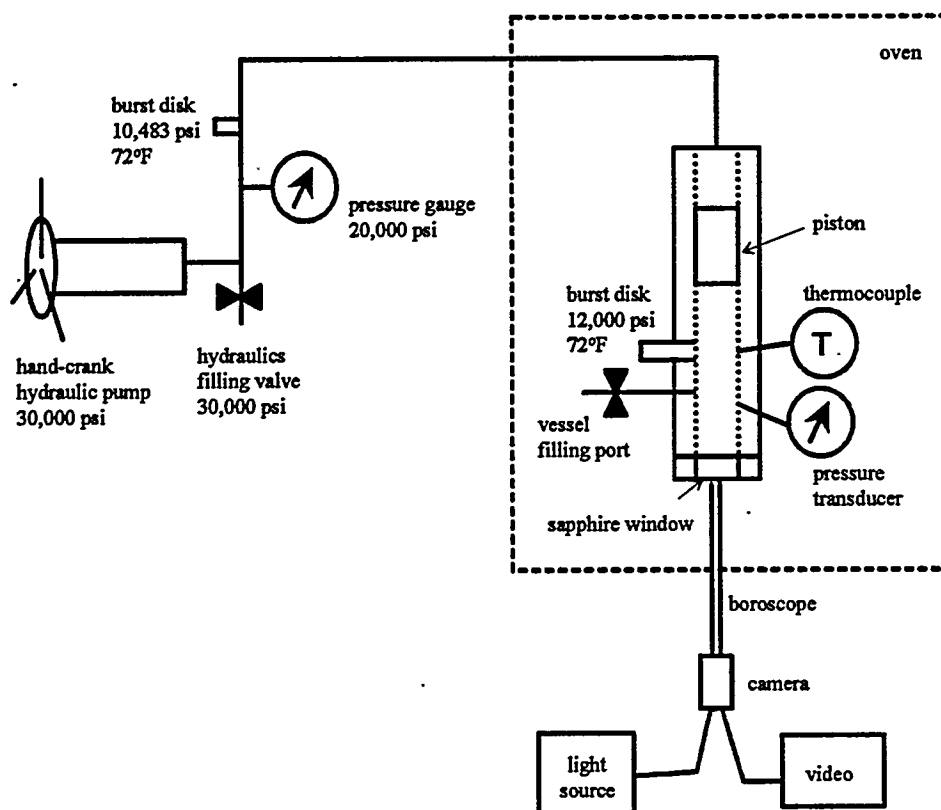

Figure 4. View Cell Apparatus for Solubility Measurements

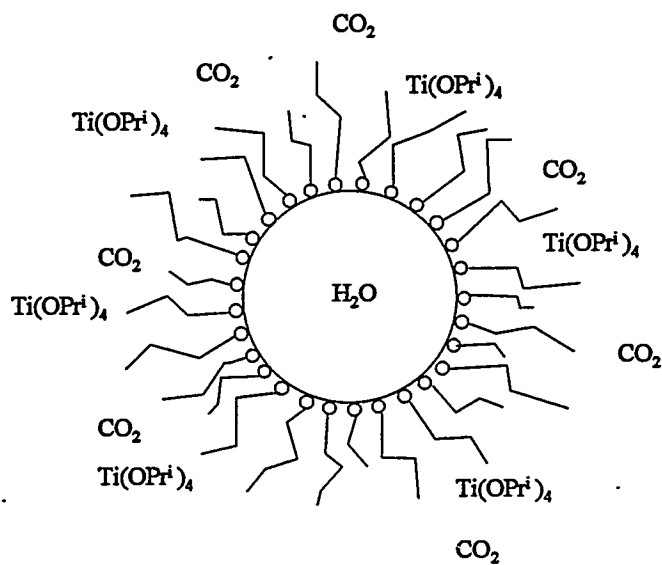

Figure 5. Schematic of Reaction Medium

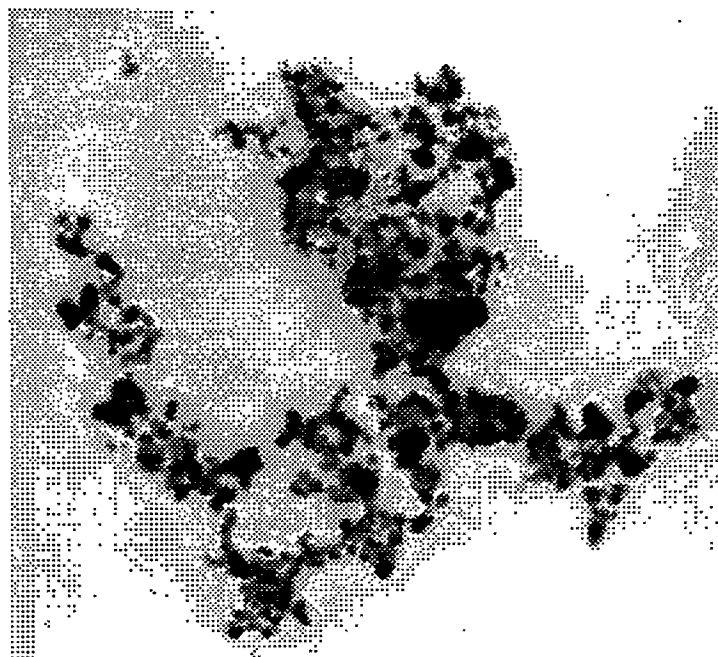

Figure 6. Silver Chloride Particles Prepared from Aqueous Solutions of $AgNO_3$ and $NaCl$ with Zonyl FSJ Surfactant. (Magnification: 1,386,000 x)

A second control experiment was carried out in which water was placed in one of the Pyrex containers and titanium(IV) isopropoxide, $\text{Ti}[\text{OCH}(\text{CH}_3)_2]_4$, in the other container. No surfactant was used. The reactor was charged with CO_2 and heated to 50°C for 4 hours. No particles were observed on the walls of the reactor, although a small amount of precipitate was observed in the water container due to diffusion of some of the soluble titanium(IV) isopropoxide in the SCCO_2 . For effective powder generation, it is necessary to bring both reactants together in the supercritical phase.

Results

In a typical experiment, 2.0 g of titanium(IV) isopropoxide are placed in one of the Pyrex containers and 1.0 g of water and 2.0 g of Zonyl FSJ were mixed and placed in the other container. The reactor was heated to 50°C for 4 hrs. A white powder was observed covering the walls of the reactor and the glass containers. Scanning electron microscopy (SEM) indicated the formation of a polydisperse, spherical powder in the 0.1- 2 micron range (see Figure 7). X-ray diffraction showed the particles to be poorly crystalline anatase (see Figure 8). Thermogravimetric and differential thermal analyses were used to study the weight loss and crystallization behavior of the powders. Typical results are depicted in Figure 9. The powder lost about 10% of its weight endothermically between 25 and 200°C . An additional 18% weight loss occurs between 200 and 300°C . The two exothermic peaks that appear at about 300 and 500°C correspond to the crystallization of anatase and rutile, respectively.

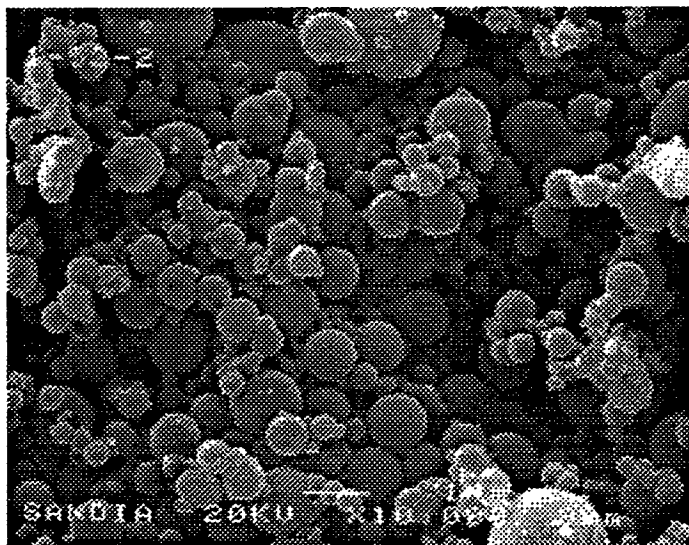

Figure 7. SEM of Titanium Dioxide Particles Prepared from $\text{Ti}[\text{OCH}(\text{CH}_3)_2]_4$, and an Aqueous Solution of Zonyl FSJ in SCCO_2 . (Magnification: 10,000 x)

A comparison of particles formed in the supercritical CO₂ environment and particles formed by hydrolysis of titanium(IV) isopropoxide in a mixture of pentanol, Zonyl F5J, and a small amount of water was carried out. Figure 10 shows that the particles formed in pentanol were not spherical.

A variety of experiments were carried out in the supercritical fluid reactor in the temperature range of 50-95°C and pressure range of 100-184 atm. The products obtained were similar to those shown in Figure 7.

Other titanium alkoxides were tested. In the case of titanium(IV) ethoxide (Ti(OC₂H₅)₄) the particles obtained were similar to those obtained using titanium(IV) isopropoxide. On the other hand, titanium(IV) butoxide (Ti[O(CH₂)₃CH₃]₄), titanium(IV) 2-ethylhexoxide (Ti[OCH₂CH(C₂H₅)(CH₂)₃CH₃]₄), or aluminum tri-*sec*-butoxide (Al[OCH(CH₃)C₂H₅]₃), did not result in formation of spherical particles. Instead a mass of irregularly shaped particles was formed in the alkoxide container (see Figure 11). Solubility measurements were made for these alkoxides in supercritical CO₂ at 40.0±0.1°C using the view cell. These data are given in Table 2. Again, it is important to remember that to uniquely define a supercritical fluid, both temperature and pressure must be specified and the solubilities in Table 2 represent the maximum alkoxide that will dissolve at 40°C and the pressure listed.

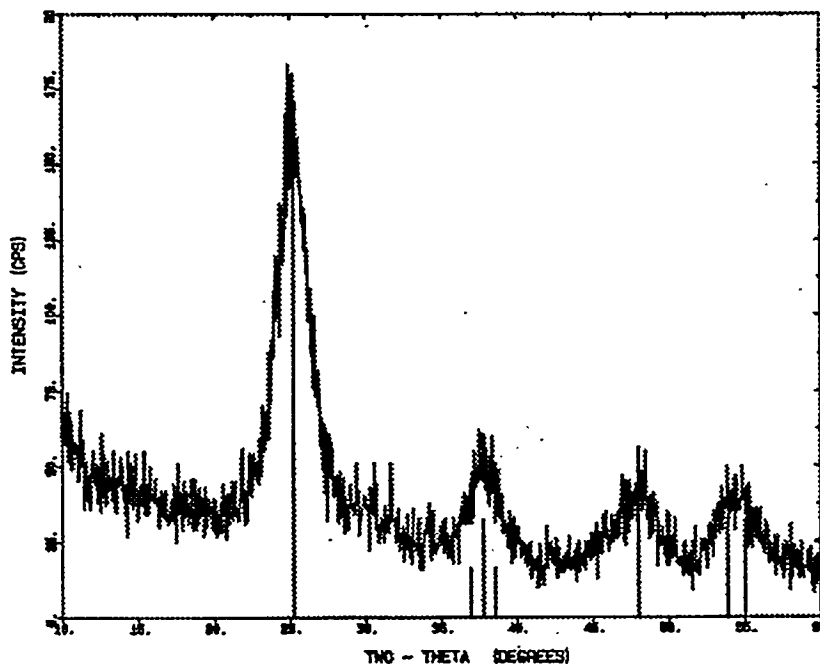

Figure 8. X-ray Diffraction Pattern of Titanium Dioxide Powder Prepared Using Reverse Micelle Technique

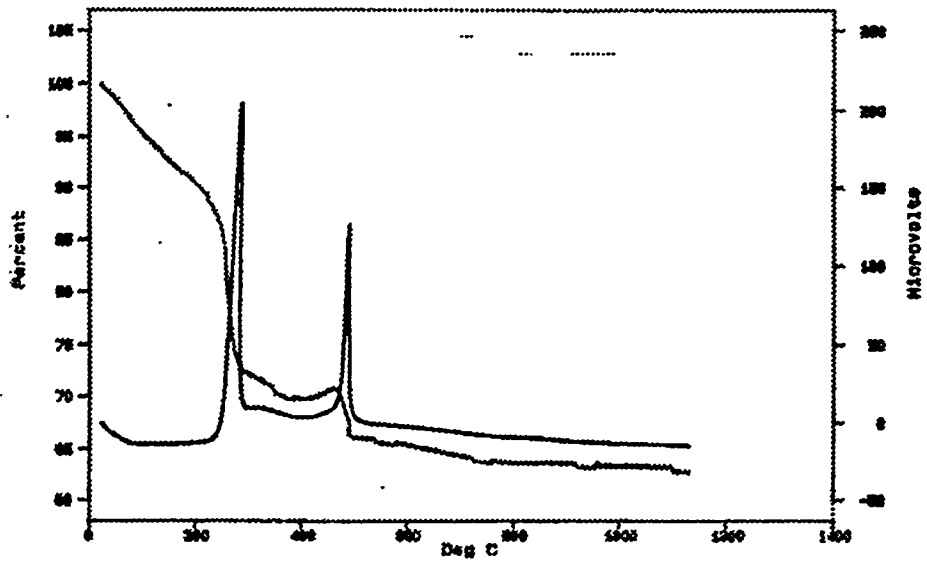

Figure 9. TGA/DTA Results for Titanium Dioxide Powder Prepared in SCCO_2 . (10°/min in air)

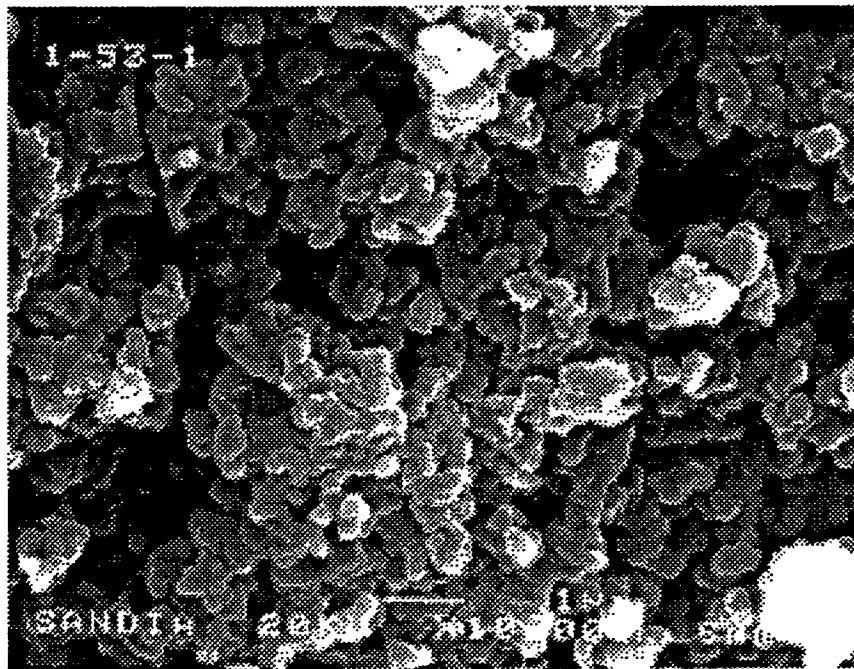

Figure 10. SEM of Titanium Dioxide Prepared by Hydrolysis of $\text{Ti}[\text{OCH}(\text{CH}_3)_2]_4$ in a Mixture of Pentanol and Zonyl FSJ. (Magnification: 10,000 x)

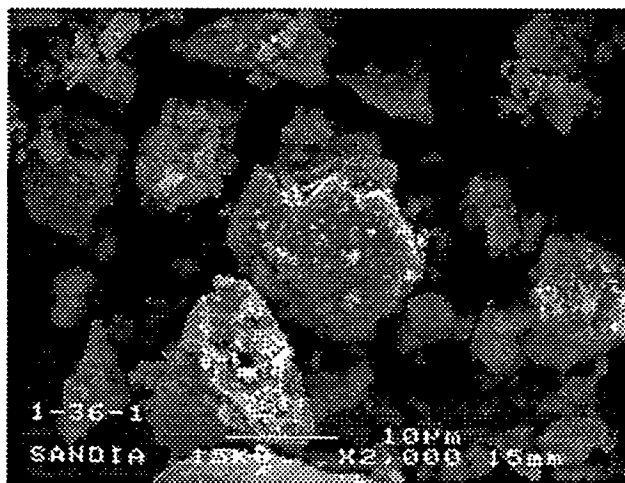

Figure 11. SEM of Titanium Dioxide Particles Prepared from $\text{Ti}[\text{OCH}_2\text{CH}(\text{C}_2\text{H}_5)(\text{CH}_2)_3\text{CH}_3]_4$ and an Aqueous Solution of Zonyl FSJ in SCCO_2 . (Magnification: 2,000 x)

The solubility of these materials in SCCO_2 loosely parallels the vapor pressure, decreasing as the vapor pressure decreases (as indicated by the boiling points). Titanium(IV) ethoxide is known to form polymeric species, tetrameric in the solid state and trimeric in benzene solutions. On the other hand, the sterically hindered titanium(IV) isopropoxide, $\text{Ti}[\text{OCH}(\text{CH}_3)_2]_4$, is monomeric. This may account for its high solubility in SCCO_2 . Titanium(IV) butoxide and aluminum tri-*sec*-butoxide are also known to form oligomers in the unhydrolyzed states. Particle formation in the supercritical phase under the conditions employed is clearly dependent on the solubility of the alkoxide. If the alkoxide is not sufficiently soluble in the SCCO_2 , the surfactant-water mixture diffuses to the alkoxide to form particles at the interface, rather than particle formation occurring in the supercritical phase.

Conclusions

Spherical particles of titanium dioxide (anatase) were prepared in supercritical carbon dioxide from titanium alkoxides and water. The dissolution of the alkoxide and stabilization of water dispersions in supercritical CO_2 were found to be critical for the formation of spherical particles. An anionic fluorinated surfactant which is soluble in SCCO_2 was used to stabilize water dispersions in the supercritical phase. Use of a hydrocarbon-based surfactants, which are not soluble in SCCO_2 , did not result in particle formation. The solubility of the titanium alkoxide in the SCCO_2 has a direct influence on particle formation and appears to parallel the vapor pressure, which is dependent on the oligomerization of the unhydrolyzed alkoxides. Polydispersity in particle sizes is due to nucleation occurring simultaneously with particle growth.

Table 2. Solubility Data for Metal Alkoxides at 40°C

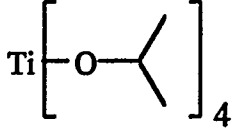
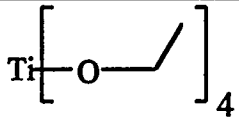
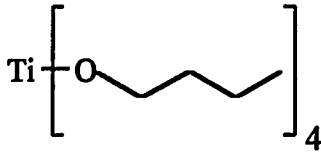
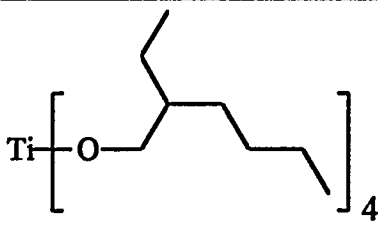
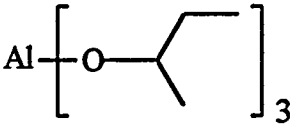
Alkoxide	P (atm)	Solubility @ 40°C, P (Weight %)	Boiling Point
 Titanium (IV) isopropoxide	81	4.25	232°C@760mm
 Titanium (IV) ethoxide	120	4.19	150°C@10mm
 Titanium (IV) butoxide	184	3.05	206°C@10mm
 Titanium (IV) 2-ethylhexoxide	353	2.21	249°C@11mm
 Aluminum tri-sec-butoxide	>612	6.13	200°C@30mm

Powder Synthesis in a Continuous Hydrothermal/Supercritical Reactor System

The rapid expansion technique is extremely dependent on the flow characteristics of the expansion nozzle. In addition, for homogeneous nucleation to occur properly in the spray, there must be no particle formation in the supercritical phase prior to expansion -- otherwise condensation would be the primary mechanism of growth. Consequently, the focus in this project was

placed on understanding particle formation (and therefore how to avoid it) in the supercritical phase reactor. Powder synthesis *in* the supercritical medium provides an opportunity to generate crystalline powders with controlled morphology and particle size distribution using a fundamental understanding of particle nucleation and growth kinetics and mechanisms. The long term goal of this effort is the development of a technique to produce “designer” powders with properties optimized for specific materials development projects. Indeed, a new project focusing on the formation of lead zirconate titanate powders for neutron generators has begun and this technique will be included.

The equipment necessary for exploring powder synthesis via rapid expansion is similar to that needed for powder synthesis via reaction in the supercritical phase. The cooling system (to chill the supercritical fluid to liquid conditions), back pressure regulator (for pressure let-down), and powder collection system can be replaced with a nozzle to convert the reaction synthesis system into a rapid expansion system provided that no particle generation occurs in the supercritical region. The apparatus, the temperature/flow rate characteristics of the system, the system operating procedure, and a test of the system in which boehmite (AlOOH) was prepared in supercritical water are discussed below for a reaction synthesis apparatus.

Equipment

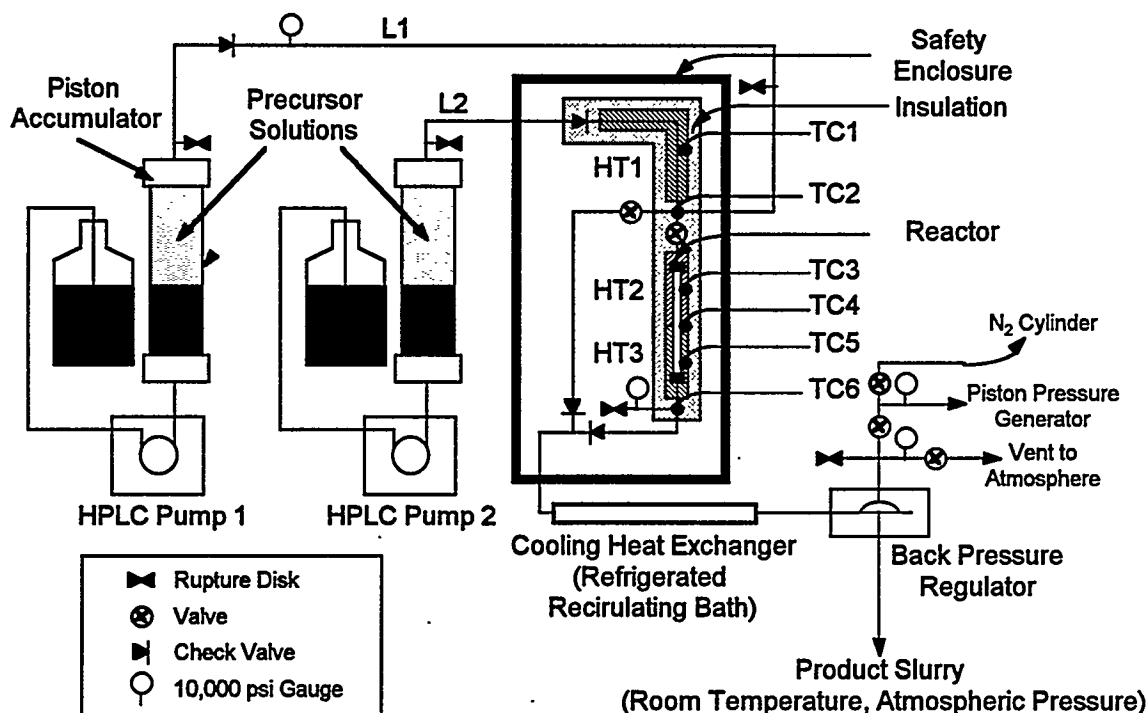

Figure 12. Continuous Hydrothermal/Supercritical Reactor System Schematic (TC = thermocouple, HT = heating tape, and L = reactant feed line)

A bench-scale continuous hydrothermal/supercritical reactor system was designed and built. A schematic of the system is shown in Figure 12. This multipurpose system is capable of operating as a continuous laminar flow tubular reactor or as a stopped-flow reactor. The system was designed to process under conditions of up to 450°C in temperature and at pressures of up to 340 atm. These operating conditions allow for solution processing of materials in an aqueous environment from single phase hydrothermal conditions up through the supercritical range. By replacing the output fitting of the tubular reactor with a orifice plate, the system can also be operated as a supercritical expansion reactor.

The system was constructed of 316 stainless steel with two reactant feed lines (L1 and L2), where the solutions were fed from two 500 ml piston accumulators driven by HPLC pumps rated to 410 atm. Basically, the feed systems are similar to having two large syringe pumps. The HPLC pumps provide highly accurate and constant flow rates regardless of system pressure. Feed L2 was fitted with a heating tape, H1, to preheat the stream before it is mixed with stream L1. The controlling thermocouple (T2) is positioned in the feed stream at the point where the two streams are mixed. This positioning of the controlling thermocouple proved to be the most efficient way of rapidly heating the two solutions to the desired temperature as they are mixed.

The tubular reactor used was 12 inches long with an interior diameter of 0.197 inches and constructed of 316 stainless steel. Only in the reactor would the water be supercritical. Supercritical water is known to be highly corrosive and often more expensive alloys, *e.g.*, Inconel, are used. However, it was felt that with monitoring, effective and safe use could be made of a stainless steel reactor based on the literature indicating that much work was being done in this area with stainless steel. The reactor section of the system was located as close to the feed stream mixing tee as the fittings would allow. Two heating tapes were used to control the reactor temperature (designated as H2 and H3 in Figure 12, referenced to thermocouples TC3 and TC5, respectively). The entire preheated section of L2 and the reactor were wrapped with insulation to help improve temperature uniformity. Because of the high thermal conductivity of the stainless steel, the feed from the reactor cooled rapidly. The reactor exit temperature of the product stream was monitored by an in-stream thermocouple (TC6) that was located as close to the exit port of the reactor as the fittings would allow. After leaving the reactor the product stream was cooled to room temperature by flowing chilled water through copper tubing that was wrapped around the tubing containing the product stream.

The pressure in the system was controlled by a back pressure regulator through which the product stream was fed before it was vented to atmospheric

pressure and collected. The back pressure regulator consisted of a diaphragm which opened when the system pressure exceeded that of the pressure set on the diaphragm side opposite of that where the product stream flowed. The procedure for operation of the reactor system is given in Appendix A.

Reactor/Flowrate Temperature Calibration

Much time was taken to insure that the two reactant feed streams could be rapidly and simultaneously mixed and heated to the desired temperature. This proved to be a difficult and time consuming task at the temperatures and pressures of interest (350-450°C and > 200 atm). It was accomplished through the use of a mixing-tee configuration in which the controlling thermocouple of the heater for one of the reactant streams (L2) was placed in the tee. The set point temperature for this heater was set to the desired reaction temperature. This resulted in the heating this stream to temperatures greater than desired to compensate for the thermal energy required to heat the feed from the other reactant stream. Experiments were carried out to map out the temperature-feed flow rate space that is allowed based on the capacity of the heating elements. Table 3 shows the results of these experiments. In general it took between 10 and 20 minutes for the system to reach equilibrium when the temperature and/or the feed flow rates were changed. The results shown in the table illustrate two of the limitations of the system. For the 300°C set point and L1/L2 flow rate combinations of 0.1/0.9 ml/min and 0.5/4.5 ml/min, the monitoring thermocouple at the center of the reactor zone (TC4) showed a temperature above that of the desired temperature. This indicates that too much thermal energy was being provided for this region of the reactor. With a higher total flow rate of 10 ml/in (L1/L2 = 1.0/9.0 ml/min), a larger load on the heating tapes evened out the temperature distribution. The other limitation is shown in the 400°C and high total flow rate (L1/L2 = 1.0/9.0 ml/min) data. For this case, the heating capacity of the tapes was exceeded and the system was not capable of reaching the desired system temperature. These limitations could be overcome with a more sophisticated heating and temperature control system.

Application to Boehmite Synthesis

The hydrolysis of aluminum salt solutions to form AlOOH (boehmite) precipitates was used as the test system for the reactor in its continuous reactor mode. The experiment was successfully completed producing the desired product. Unfortunately, during this experiment one of the HPLC pumps malfunctioned. Extensive delays in its repair by the manufacturer, prevented further experimentation. However, it was demonstrated that the system would operate under either hydrothermal or supercritical conditions. The equipment

will be used in fundamental studies of lead zirconate titanate particle growth as part of a new project looking the solution synthesis of these materials for neutron generator applications.

Table 3. Temperature-Flowrate Characteristics of the Flow Reactor System (Pressure = 272 atm (water was used in L1 and L2))

Set Temp (°C)	Flowrate (ml/min)		Thermocouple Readings (°C)					
	L1	L2	TC1	TC2	TC3	TC4	TC5	TC6
300	0.1	0.9	277	299	300	327	302	72
300	0.5	4.5	252	294	297	327	302	220
300	1.0	9.0	299	300	299	298	303	264
350	1	4	318	347	346	349	350	275
350	2	3	352	351	351	355	351	248
400	0.1	0.9	368	398	400	398	401	126
400	0.5	4.5	389	397	396	392	399	325
400	1	9	310	292	389	389	394	356
400	1	4	403	397	399	393	399	351

Conclusions

The continuous flow reactor was constructed first and based on the difficulty in establishing a constant temperature profile that was flowrate insensitive and the maintenance difficulties, it was decided that there is a distinct benefit to operating at the lower pressures and less corrosive conditions associated with carbon dioxide. The use of surfactants, provided they are soluble and form micelles in the supercritical fluid, greatly extends the regime in which carbon dioxide can be considered as a reaction medium. It was demonstrated that either the water continuous flow or carbon dioxide reverse micelle technique can be used to generate ceramic powders. The control and equipment is difficult to maintain in the high temperature, high pressure water system. The reverse micelle technique has definite advantages if the fluid of interest (for instance, ammonia) is not considered safe to work with in large quantities. Appropriate use of micelles would minimize the active fluid volume and potentially lead to the formation of non-oxide ceramics.

References

1. P. Stamatakis, C. A. Natalie, B. R. Palmer and W.A. Yuill, *Aerosol Sci. and Technol.*, **14**(3), 316 (1991).
2. B. J. Ennis, J. Green and R. Davies, *Chemical Engineering Prog.*, **90**(4), 32 (1994).
3. D. W. Matson, R. C. Peterson and R. D. Smith, *J. Matls. Sci.*, **22**, 1919 (1987).
4. D. W. Matson, J. L. Fulton, R. C. Petersen and R. D. Smith, *Ind. Engr. Chem. Res.*, **26**, 2298 (1987).
5. C. Pommier, K. Chhor, J. F. Bocquet and M. Barj, *Matl. Res. Bull.*, **25**, 213 (1990).
6. M. Barj, J. F. Bocquet, K. Chhor, and C. J. Pommier, *J. Matls. Sci.*, **27**, 2187 (1992).
7. C. J. Pommier, K. Chhor, J. F. Bocquet and M. Barj, *Ind. Ceram., Verriere*, **881**, 260 (1993).
8. T. Adschiri, K. Kanazawa and K. Arai, *J. Amr. Ceramic Soc.*, **74**(4), 1019 (1992).
9. D. W. Matson, J. L. Fulton, and R. D. Smith, *Materials Letters*, **6**(1,2), 31 (1987).
10. K. A. Consani and R. D. Smith, *J. Supercritical Fluids*, **3**, 51 (1990).
11. T. A. Hoefling, D. A. Newman, R. M. Enick and E. J. Beckman, *J. Supercritical Fluids*, **6**, 165 (1993).
12. T. A. Hoefling, R. M. Enick and E. J. Beckman, *J. Phys. Chem.*, **95**, 7127 (1991).
13. J. M. DeSimone, E. E. Maury, Y. Z. Menceloglu, J. B. McClain and T. J. Romack, *Science*, **265**, 356 (1994).
14. A. Iezzi, P. Bendale, R. M. Enick, M. Turberg, and Brady, *Fluid Phase Equilibria*, **52**, 307 (1989).
15. M. Dvolaitzky, R. Ober, C. Taupin, A. Anthore, X. Auvray, C. Petipas and C. J. Williams, *J. Dispersion Sci. Tech.*, **4**, 29 (1983).
16. R. W. Gale, J. L. Fulton and R. D. Smith, *J. Amr. Chem. Soc.*, **109**, 920 (1987).

DISTRIBUTION:

1	MS 0333	A. J. Hurd, 1841
1	0333	M. E. Tadros, 1841
1	1349	J. Cesarano, 1841
1	1407	J. H. Aubert, 1815
1	0367	C. L. J. Adkins, 1815
1	0367	E. M. Russick, 1815
1	1405	J. A. Voigt, 1846
1	1405	B. Hammetter, 1846
1	1435	H. J. Saxton, 1800
1	1436	C. Meyers, 1011
1	9018	Central Technical Files, 8523-2
5	0899	Technical Library, 4414
1	0619	Print Media, 12615
2	0100	Document Processing, 7613-2 For DOE/OSTI

