

Sludge Processing Options for early HLW Treatment at Hanford

September 2022

Amy M Westesen
Ashley N Williams
Reid A Peterson
Carolyn A Burns

DISCLAIMER

This report was prepared as an account of work sponsored by an agency of the United States Government. Neither the United States Government nor any agency thereof, nor Battelle Memorial Institute, nor any of their employees, makes **any warranty, express or implied, or assumes any legal liability or responsibility for the accuracy, completeness, or usefulness of any information, apparatus, product, or process disclosed, or represents that its use would not infringe privately owned rights.** Reference herein to any specific commercial product, process, or service by trade name, trademark, manufacturer, or otherwise does not necessarily constitute or imply its endorsement, recommendation, or favoring by the United States Government or any agency thereof, or Battelle Memorial Institute. The views and opinions of authors expressed herein do not necessarily state or reflect those of the United States Government or any agency thereof.

PACIFIC NORTHWEST NATIONAL LABORATORY
operated by
BATTELLE
for the
UNITED STATES DEPARTMENT OF ENERGY
under Contract DE-AC05-76RL01830

Printed in the United States of America

Available to DOE and DOE contractors from the
Office of Scientific and Technical Information,
P.O. Box 62, Oak Ridge, TN 37831-0062;
ph: (865) 576-8401
fax: (865) 576-5728
email: reports@adonis.osti.gov

Available to the public from the National Technical Information Service
5301 Shawnee Rd., Alexandria, VA 22312
ph: (800) 553-NTIS (6847)
email: orders@ntis.gov <<https://www.ntis.gov/about>>
Online ordering: <http://www.ntis.gov>

Sludge Processing Options for early HLW Treatment at Hanford

September 2022

Amy M Westesen
Ashley N Williams
Reid A Peterson
Carolyn A Burns

Prepared for
the U.S. Department of Energy
under Contract DE-AC05-76RL01830

Pacific Northwest National Laboratory
Richland, Washington 99354

Abstract

The U.S. Department of Energy's (DOE) Hanford Site has 177 underground storage tanks that contain wastes from past nuclear fuel reprocessing and waste-management operations. Over 20% of this waste is in the form of an insoluble sludge that will require solids concentration and washing prior to vitrification for long-term disposal. An assessment of potential flowsheet operations to support feed preparation activities prior to high level waste (HLW) vitrification has been conducted to better evaluate pretreatment processing options. Settling studies assessing the baseline approach of a settle-decant method were explored as well as a crossflow filtration system to be used alternatively for concentrating and washing HLW sludge. Significant variations in behavior of settling rates and sludge characteristics give reason to evaluate alternative pretreatment options for the HLW. Non-radioactive sludge containing iron oxide, boehmite, and gibbsite were evaluated via gravity settling and crossflow filtration to determine the behavior of these compounds in various tank waste matrices. Understanding the predictive capabilities of HLW solids settling as well as sludge concentration via crossflow filtration can help provide technical guidance during flowsheet planning.

Summary

This report summarizes the work performed under FY22 LDRD “HLW Sludge Processing Options”. Settling of high-level waste (HLW) solids in process vessels is a key conceptual process step in providing HLW sludge feed to the Hanford Waste Treatment and Immobilization Plant (WTP) HLW Facility. Potential flowsheet options that could enable flexibility in startup of HLW vitrification prior to completion of all planned WTP Facilities are potentially desirable. To support planning for sludge feed to HLW, settling studies and crossflow filtration with Fe and various Al phases were conducted. Characterization of Hanford tank sludge shows Al and Fe make up the majority of prevalent metals in the waste solids, after Na. Red iron oxide was used as the Fe source and processing behaviors were examined in the presence of boehmite and gibbsite, two Al phases known to impact both settling and filtration.

Three simulants, representing Al phases found in the largest fractions of the total sludge inventory were evaluated in 1, 2.5, and 5 M NaOH matrices to represent tank conditions at potential processing stages. Gravity induced settling rates with initial solids concentrations ranging from 4 - 32 wt% showed significant dependence on both initial solids concentration and NaOH concentration. As initial solids concentration increased in the feed, there was a proportionate decrease in the hindered settling rate observed. Additionally, viscosity and density impacts from increasing NaOH concentration resulted in slower settling rates in 5 and 2.5 M NaOH compared to 1 M NaOH. Final solids consolidation (vol %) appeared relatively independent of the initial solids concentration, however, the final solids concentration (vol%) decreased as a function of increased NaOH concentration.

Bench-scale filtration testing with 9.2 kg’s of each simulant feed were conducted using crossflow filtration to assess an alternative processing potential for concentrating and washing HLW sludge. The feeds were recirculated through the system at a targeted 2.1 m/s while the permeate flowrate was allowed to drift freely. A constant temperature and transmembrane pressure 20 °C and 138 kPa (20 psid), respectively, were maintained for each testing evolution. Filter feeds were prepared at 8 wt% solids in 5, 2.5 and 1 M NaOH. Slurries were dewatered to concentrate the solids in the system up to nominally 20 wt%. The impact of washing the slurry from 5 M NaOH to 1 M NaOH was seen through an increase in filter flux for all three slurry feeds. Simulant slurry with iron oxide and gibbsite did not operate in the cake-formation regime and displayed a relatively constant permeate flowrate despite the increasing wt% undissolved solids (UDS) in the system. Simulants containing boehmite transitioned to the post-cake formation region quickly and showed excellent extrapolation to the gel-point maximum. For eventual waste treatment processes, the overall impact of centrifuged solids on either filtration or settle/decant are contrasting. Samples with lower centrifuged solids loadings will have high filtration throughput but lower settling rates. Thus, samples with high centrifuged solids loading will result in higher settling rates but lower filtration rates. This dependence will need to be considered when determining the best pretreatment flow path for varying tank chemistries.

Acknowledgments

This research was supported by the **EED Seed Investment**, under the Laboratory Directed Research and Development (LDRD) Program at Pacific Northwest National Laboratory (PNNL). PNNL is a multi-program national laboratory operated for the U.S. Department of Energy (DOE) by Battelle Memorial Institute under Contract No. DE-AC05-76RL01830. The authors thank Renee Russell for conducting the technical review of this report and Matt Wilburn for his technical editing contribution on this report.

Contents

Abstract.....	ii
Summary.....	iii
Acknowledgments.....	iv
1.0 Introduction	1
2.0 Experimental Methods	2
2.1 Simple Sludge Simulants: Analytes-of-Interest Chemistry	2
2.2 Gravity Settling and Centrifugation.....	2
2.3 Crossflow Filtration.....	4
3.0 Results	6
3.1 Physical Properties.....	6
3.1.1 Gravity Settling Results	6
3.1.2 Centrifuged Solids	12
3.1.3 Particle Size Distribution (PSD).....	13
3.2 Crossflow Filtration.....	14
4.0 Conclusions.....	17
5.0 References.....	18

Figures

Figure 1 Settling Cycle of a Suspension	3
Figure 2 Filter System Piping & Instrumentation Diagram	5
Figure 3 Interface distinction between 8 and 16 wt% at 1-, 2-, 4-, and 8-minute settling intervals	8
Figure 4 Dimensional Settling Curve for Simulant 1 (Iron Oxide and Boehmite)	9
Figure 5 Dimensional Settling Curve for Simulant 2 (Iron Oxide and Gibbsite)	9
Figure 6 Dimensional Settling Curve for Simulant 3 (Iron Oxide, Boehmite and Gibbsite).....	10
Figure 7 Insoluble Solids Concentration for Simulant 1 (Iron Oxide and Boehmite).....	11
Figure 8 Insoluble Solids Concentration for Simulant 2 (Iron Oxide and Gibbsite).....	11
Figure 9 Insoluble Solids Concentration for Simulant 3 (Iron Oxide, Boehmite and Gibbsite).....	12
Figure 10 PSD of Slurries on a Volume-Weighted Bases for Simulants 1, 2, and 3 in Cumulative Under-Size-Percentage Distribution.....	13
Figure 11 Dewatering of Simulant 1 from 8 wt% to 20 wt% in 1, 2.5 and 5 M NaOH	15
Figure 12 Dewatering of Simulant 2 from 8 wt% to 20 wt% in 1, 2.5 and 5 M NaOH	15
Figure 13 Dewatering of Simulant 3 from 8 wt% to 20 wt% in 1, 2.5 and 5 M NaOH	16

Tables

Table 1 Simulant and Hanford Sludge Properties Comparison	2
Table 2 Composition of simulant Hanford sludge in 5 M NaOH (basis 9.17 kg).....	5
Table 3 Simulant Settling Test Results	6
Table 4 Simulant Centrifuged Solids Measurements, wt%	12
Table 5 Summary of Cumulative Under-Size-Percentage Distribution and Mean Volume- Weighted Distribution for Simulants 1, 2, and 3	13
Table 6 Summary of Crossflow Filtration Results for Simulants 1, 2, and 3	14

1.0 Introduction

The Hanford site currently houses 56 million gallons of hazardous and radioactive waste stored in underground tanks. Hanford's tanks contain a mixture of supernate, water-soluble saltcake, and water-insoluble sludge. The saltcake and supernate will be processed to remove cesium, and then immobilized as low-activity waste. The tank sludges, on the other hand, contain the bulk of the radionuclides and will be pretreated separately and disposed of as high-level waste (HLW). To minimize their impact on the final waste volume, these sludges will be retrieved from the tank and pretreated to separate out the bulk of the interstitial supernate prior to HLW vitrification.

Alternative flowsheet options that could enable timeline flexibility in startup of HLW vitrification prior to completion of all planned WTP Facilities are potentially desirable. Settling of HLW solids in process vessels is a primary process step used at the West Valley Demonstration Project and at the Savannah River Site and also in conceptual flowsheets for providing early HLW feed to the WTP HLW Vitrification Facility. Part of the challenge for in tank processing is the paucity of settling data to confirm process conditions. Preliminary assessments indicate that the time available for settling may be as little as 14 days, which is not universally supported by the settling data (Wells et al. 2020). In addition, the average solids concentration needed in the slurry feed to the HLW vitrification facility is nominally 15 wt% solids, however, the measured average solids concentration in existing HLW sediment can vary from less than 7 wt% to greater than 74 wt% solids (Wells et al. 2020). These disparities can pose a process challenge for creating optimal melter feed conditions when planning for the application of a settle/decant process for HLW feed delivery. Additional variations in behavior of settling rates and sludge characteristics give reason to evaluate alternative pretreatment options for HLW. As such, a treatment process has been proposed that will utilize crossflow filtration to filter supernate and concentrate HLW sludge. Filtration of the waste can be necessary to remove components such as aluminum, sodium, and phosphorus that are soluble in water and often limit the waste loading of glass.

To support HLW flowsheet options analysis, non-radioactive sludge simulants targeted to represent Fe and Al phases found in the largest fractions of the total sludge inventory were evaluated by gravity settling and crossflow filtration. This report compares the behavior of AlOOH (boehmite) and Al(OH)₃ (gibbsite) on the aforementioned pretreatment options to determine their impacts on waste processing.

2.0 Experimental Methods

The settling studies and crossflow filtration were conducted on three sludge slurries comprised of iron oxide and various amounts of AlOOH (boehmite) and/or Al(OH)₃ (gibbsite). A brief description of the equipment and testing for each of these studies are described in the sections below.

2.1 Simple Sludge Simulants: Analytes-of-Interest Chemistry

The simple simulant sludges used in this testing are summarized in Table 1. Compounds in the sludge were chosen based on comparison to actual Hanford sludge chemical and physical properties, including liquid density, pH, and UDS particle size. The simulants represent the bulk aluminum-containing sludges based on the predominant Al phase (gibbsite or boehmite). Included in Table 1 are a complex simulant and actual Hanford sludge previously characterized by PNNL (Russell et al. 2009, Wells et al. 2010). All sludges were prepared in 1, 2.5 and 5.0 M NaOH to represent potential HLW processing conditions.

Table 1 Simulant and Hanford Sludge Properties Comparison

Property	Simulant 1	Simulant 2	Simulant 3	Complex Simulant CBM-3 ¹	Hanford Sludge ²	
Solid Phase	Iron Oxide, 0.5	Iron Oxide, 0.5	Iron Oxide, 0.33	Iron Oxide, 0.14	Iron Oxide, 0.078	
Compound,	Boehmite, 0.5	Boehmite, 0.0	Boehmite, 0.33	Boehmite, 0.355	Boehmite, 0.115	
Mass Fraction	Gibbsite, 0.0	Gibbsite, 0.5	Gibbsite, 0.33	Gibbsite 0.355	Gibbsite, 0.449	
PSD	d10	12	1.3	6.8	1.6	1.0
Percentile	d50	68	32	41	9.5	6.3
(μm)	d90	161	91	101	36	59
(1) Russell et al. (2009)						
(2) Wells et al. (2010)						

2.2 Gravity Settling and Centrifugation

Settling behavior of the simulant sludge was determined by both gravity settling and centrifugation. Aliquots of the samples were allowed to settle in graduated cylinders from initial weight percent's ranging from 4 to 32 wt%. The height of the sediment bed and total sample height were recorded as a function of time. Samples were then centrifuged and the volume of the centrifuged supernate and centrifuged solids were recorded. To obtain representative aliquots, the simulants were well mixed before being transferred into the graduated cylinder or centrifuge cone. At the start of these settling tests, each aliquot was well mixed by inverting and shaking up the solution.

As the samples settled, an interface developed between the turbid solution and clear supernate. The sediment volume is the volume from the bottom of the suspension column to the interface between the clear supernate and cloudy suspension. Under the force of gravity, the solids in the suspension sank to the bottom of the cylinder, forming a sludge layer and a clear supernate layer. The final sediment bed volume was measured after no significant change was observed in the height of this sludge layer over 1 hour. The volume percent settled solids were then determined by dividing the final sediment bed volume by the total volume of the slurry. Figure 1 provides a schematic illustration of the settling cycle of a suspension, the portion where the interface is defined by hindered settling is noted as the linear region of the settling graph. This initial settling behavior is observed to descend in a fast, linear manner that is consistent with a nearly constant velocity. As the settling rate begins to deviate from the linear trend, the system shifts from predominately hindered settling to compaction. During compaction, the sediment is almost completely settled but is gradually consolidated under its own weight. This interface motion is slow and typically not at a constant velocity.

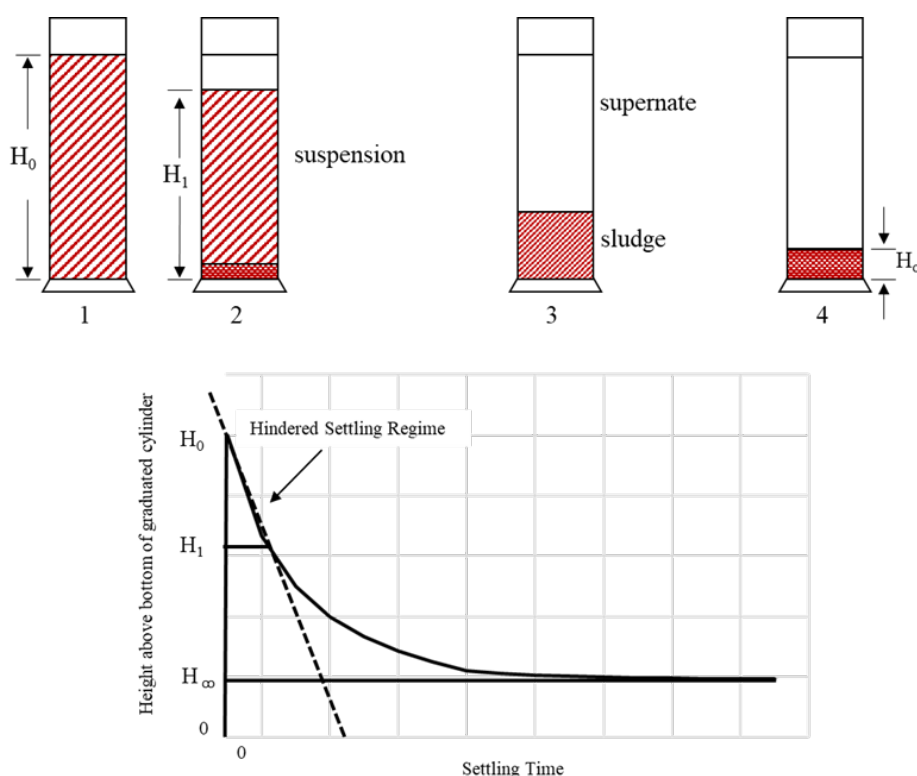

Figure 1 Settling Cycle of a Suspension

The settling rate measured by this method is controlled by the settling rate of the smallest particles in the suspension. In a suspension with particles of uniform size, all the particles will settle at the same rate, and a sharp boundary will exist between the clarified portion of the settling system and the fraction of the system where the particles are still settling. Hanford tank wastes (and the sludge simulants reported herein) are polydisperse systems, where each size fraction settles at its own characteristic velocity. The rate at which a particle settles in a suspending liquid depends on the size, shape, and density of the particle as well as the density and viscosity of the suspending medium. Stoke's law provides a mathematical expression of the terminal settling velocity for spherical particles shown in Equation (1). It should be noted that the solids used in this testing are asymmetric and will experience an increase on the friction factor of the settling particle, which decreases the settling rate when compared to a spherical particle.

$$W_{s,0} = \frac{(\rho_s - \rho_w)gd^2}{18\mu} \quad (1)$$

where,

$W_{s,0}$ = Stoke's settling rate, m/s

ρ = density, g/mL

g = gravitational acceleration, m/s²

d = particle diameter, cm

μ = viscosity, Pa*s

Interstitial liquid associated with the settled solids was further separated from the solids by centrifugation. The sediment volume was measured on each aliquot as a function of time. The volume percent centrifuged solids was then determined by dividing the sediment volume by the total volume of the slurry. Since the solutions were prepared using dry mass of solids, the weight percent supernate and centrifuged solids were calculated by dividing their individual mass by the total slurry mass.

2.3 Crossflow Filtration

Crossflow filtration was conducted on 9.2 kg's of each simulant feed. Simulants were prepared at a nominal 8.0 wt% solids in 5 M NaOH to represent unwashed retrieved sludge from double-shell tanks. After concentrating the slurry up to 20 wt% during dewatering operations, deionized water was added to the feed reservoir to drop the Na concentration down to 2.5 M Na and 8 wt% solids. This was done again after dewatering the slurry at 2.5 M Na to drop the concentration down to 1 M NaOH. The crossflow filter element used in testing was an 8-foot-long, 0.5-in ID Mott media grade 0.1, 316 L sintered stainless steel symmetric element. Figure 2 shows the filter System Piping & Instrumentation Diagram (P&ID) for the filtration apparatus.

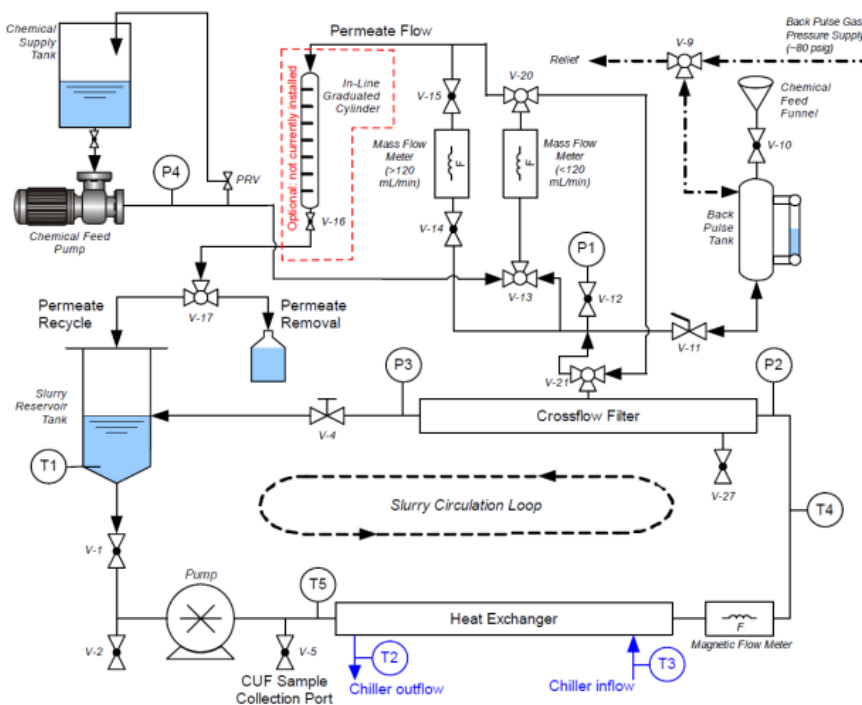

Figure 2 Filter System Piping & Instrumentation Diagram

Transmembrane pressure profiles and temperature were kept at a constant 138 kPa (20 psid) and 20 °C for each test. The slurries were recirculated through the filter element at an axial velocity of 2.1 m/s (7 ft/s) and the permeate flowrate was allowed to drift. The filter unit was operated in constant dewatering mode to increase the slurry concentration from a feed condition of 8 wt% to a targeted 20 wt%. Before a test condition was changed (NaOH M or slurry feed), a back-pulse on the filter was conducted to restore permeate flux to the starting condition. Composition of the simulants used in the testing are shown in Table 2.

Table 2 Composition of simulant Hanford sludge in 5 M NaOH (basis 9.17 kg)

Component	Simulant 1 (mass, g)	Simulant 2 (mass, g)	Simulant 3 (mass, g)
Iron Oxide (Fe ₂ O ₃)	367.0	367.0	244.5
Boehmite (AlOOH)	367.0	-	244.5
Gibbsite (Al(OH) ₃)	-	367.0	244.5
50 wt% NaOH	2875	2875	2875
Density, g/mL	1.177	1.170	1.173

3.0 Results

Potential flowsheet operations were conducted on simple simulants containing Fe and Al phases to evaluate HLW pretreatment processing options. Settling studies assessing the in-tank settle-decant method were explored as well as an at-tank crossflow filtration system to be used alternatively for concentrating and washing HLW sludge.

3.1 Physical Properties

Three sludge slurries comprised of iron oxide and various amounts of AlOOH (boehmite) and/or Al(OH)₃ (gibbsite) were evaluated by gravity settling, centrifugation, and particle size distribution. This section discusses the physical property results from these tests.

3.1.1 Gravity Settling Results

Settling tests were performed on the three simulant sludge compositions in NaOH matrices of 1, 2.5 and 5 M NaOH. The settling conditions, velocities, and solids concentrations for these tests are shown in Table 3. The solids and the supernate separated with varying distinctions of the interface depending on the initial solid's concentration. For simulants containing 16 wt% or greater, a discrete separation was seen between the suspension and clear supernate. Figure 3 shows the visual differentiation in clarity between the 8 and 16 wt% settling slurries at time stamps of 1, 2, 4, and 8 minutes for simulant 1. In all cases, the interface formed within the first 2 minutes of settling. For most of the experiments, the solution clarified within 15 minutes from the formation of the interface (clarity was based on there being no visible particles in solution). The cloudiness was the result of fine particles of iron oxide remaining suspended in the supernate even after the bulk of the sludge material has settled. As these smaller particles settled, the solution cleared.

Table 3 Simulant Settling Test Results

Slurry Feed	Initial Solid Concentration (wt%)	NaOH Concentration, M	Hindered Settling Rate (cm/min)	Final Solid Concentration (wt%)
Simulant 1	4	1	2.90	42
		2.5	1.22	37
		5	0.33	30
	8	1	1.32	40
		2.5	0.52	36
		5	0.06	28
	16	1	0.35	41
		2.5	0.12	40
		5	0.01	37
	24	1	0.16	44
		2.5	0.04	40
	32	1	0.05	42
2.5		0.04	43	

Table 3 Simulant Settling Test Results Continued

Simulant 2	4	1	1.75	47
		2.5	0.86	45
		5	0.87	41
	8	1	0.85	43
		2.5	0.39	38
		5	0.24	41
	16	1	0.21	50
		2.5	0.19	53
		5	0.08	45
	24	1	0.11	47
		2.5	0.09	53
	32	1	0.07	48
2.5		0.05	53	
Simulant 3	4	1	1.69	43
		2.5	0.81	41
		5	0.22	34
	8	1	0.75	39
		2.5	0.27	40
		5	0.10	34
	16	1	0.17	44
		2.5	0.08	45
		5	0.02	39
	24	1	0.08	42
		2.5	0.04	46
	32	1	0.04	45
2.5		0.02	43	

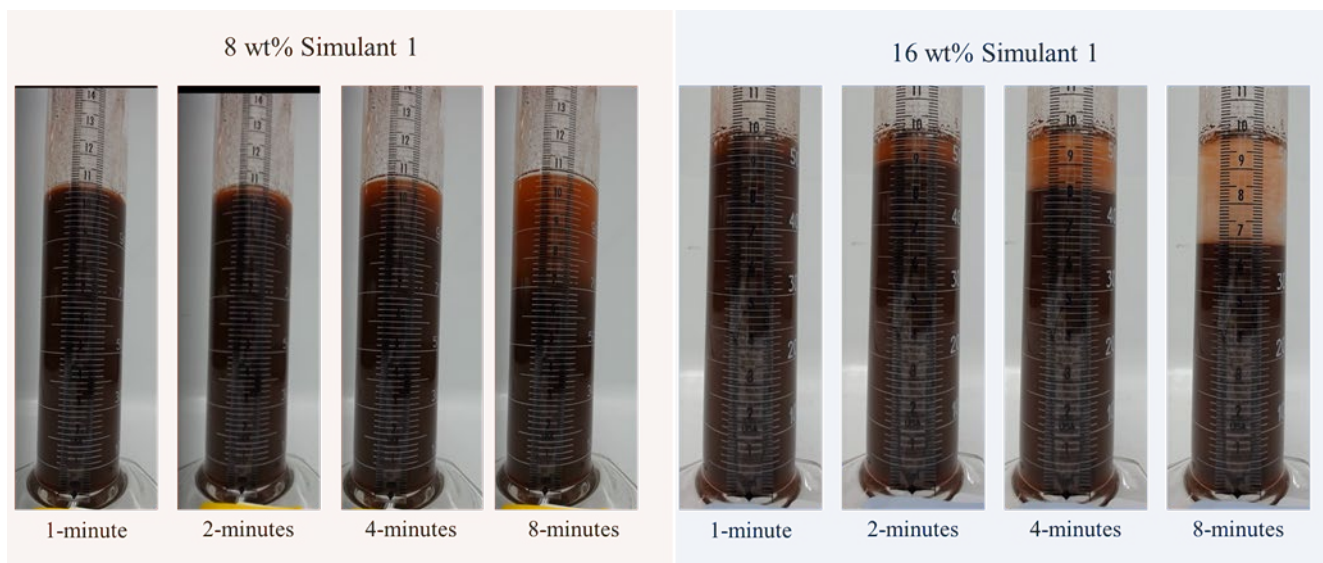

Figure 3 Interface distinction between 8 and 16 wt% at 1-, 2-, 4-, and 8-minute settling intervals

Several trends can be seen from the settling results in Table 3. The hindered settling rate appears to be strongly concentration dependent. Increases in solids concentration results in a proportionate decrease in the hindered settling rate. Furthermore, the sludge settles fastest in 1 M NaOH, next fastest in 2.5 M NaOH, and slowest in the 5 M NaOH. This is consistent with expectations since 5 M NaOH has a viscosity 30% greater than that of 1 M NaOH, and the Stokes settling velocity is inversely proportional to viscosity and solution density.

The settling curves for the above data are shown in Figure 4 through Figure 6 and are similar to those typically seen for hindered settling. The hindered settling region is a relatively straight line followed by a slowing of the settling during compaction. The maximum settling rate is taken from a linear regression of the hindered settling region. For the tests shown here, hindered settling is complete within 30 to 60 minutes. Compaction usually required 1 to 6 hours.

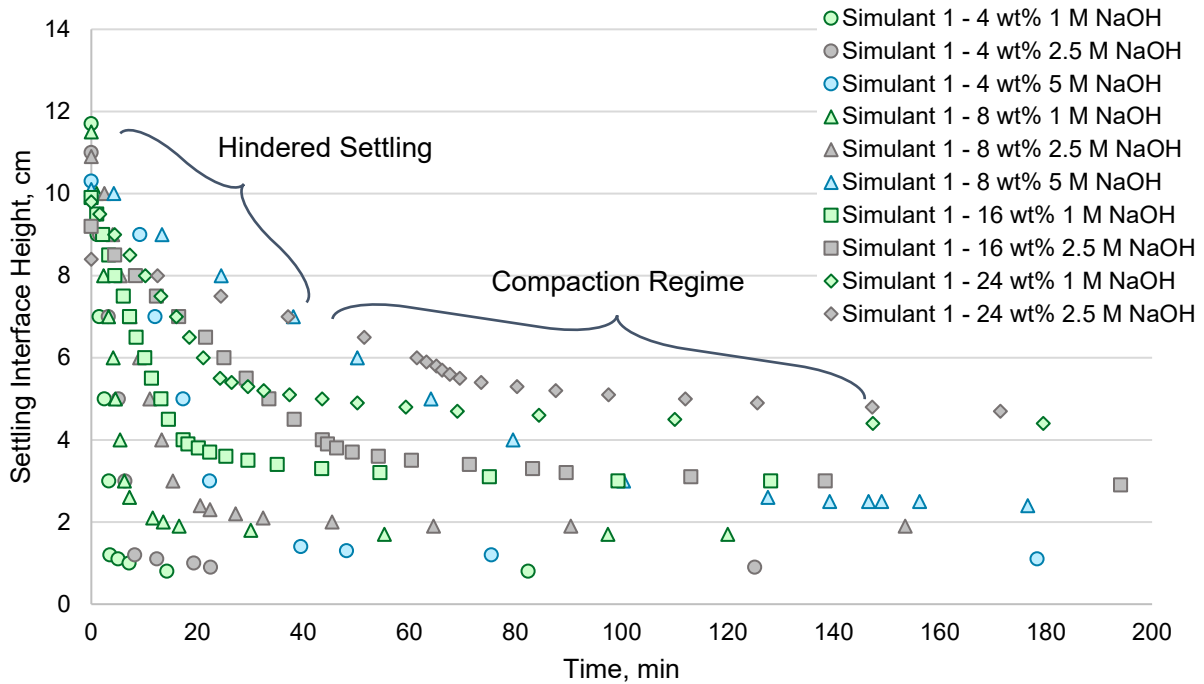

Figure 4 Dimensional Settling Curve for Simulant 1 (Iron Oxide and Boehmite)

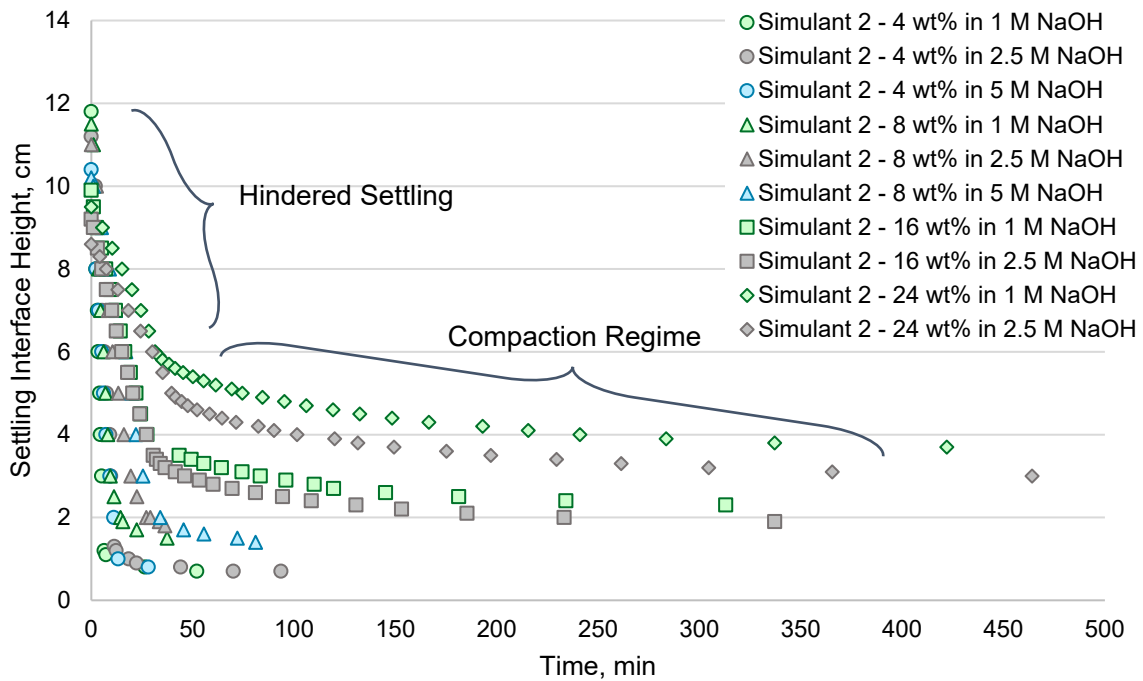

Figure 5 Dimensional Settling Curve for Simulant 2 (Iron Oxide and Gibbsite)

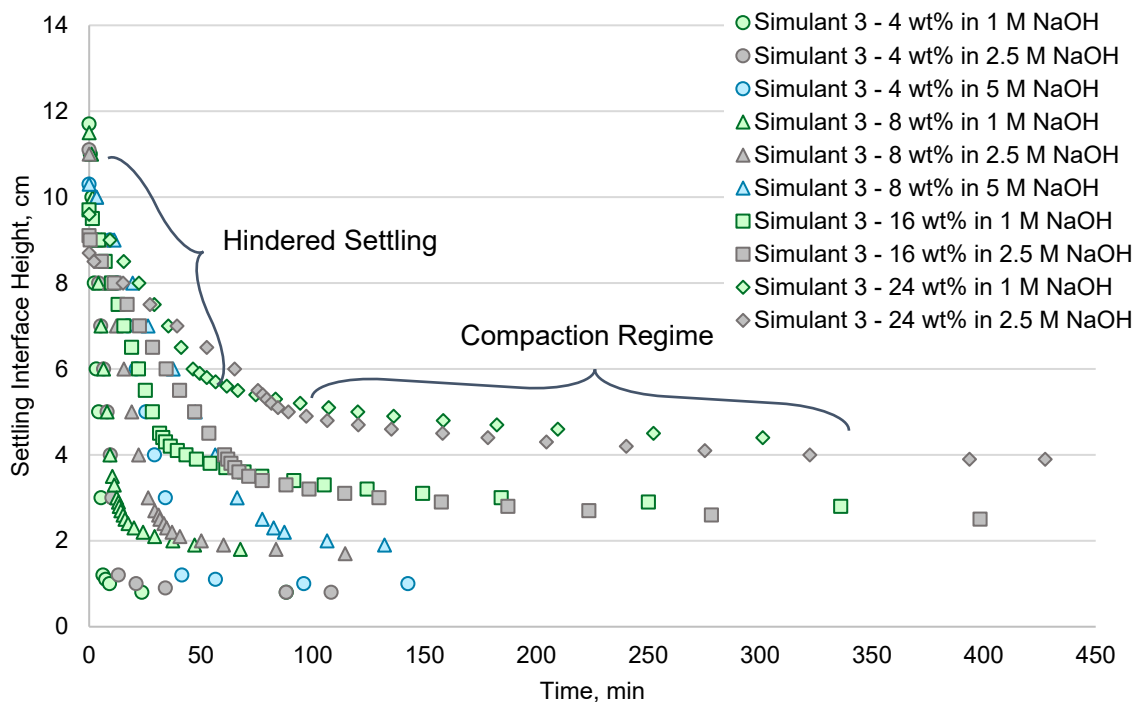

Figure 6 Dimensional Settling Curve for Simulant 3 (Iron Oxide, Boehmite and Gibbsite)

Figure 7 through Figure 9 provide the same settling data in terms of solids concentration vs time. As can be seen from the figures, final compaction is relatively independent of the initial solids concentration. These results are reasonable considering the final compaction is based on sludge height, which was nearly constant through all tests. The rate of compaction appeared to decrease as a function of increased NaOH concentration. Additionally, the final solids concentration in the sediment decreases as a function of increasing NaOH concentration. This is likely a result of changes in the particle-particle interactions during the course of the settling process. For example, at higher ionic strength matrices, repulsive electrostatic forces between particles become more significant, making the compaction of the sludge more difficult. In all slurries, the maximum settled solids concentration averaged 42 ± 5.5 wt%. It is important to recognize, if a potential HLW slurry feed target concentration is 15-20 wt%, a potential settled layer target will need to be much higher (30-40 wt%) to represent a condition where supernate liquid could be decanted to the extent that, when remaining supernate liquid and sediment are mixed, the potential feed slurry solids concentration can be achieved. Slurries tested here show no indication of being problematic with respect to using a settle/decant process to achieve slurry concentrations, however, it should be noted that compounds of Al and Fe used for this testing were selected to match chemical performance but may not represent the exact phases present in Hanford tank sludge.

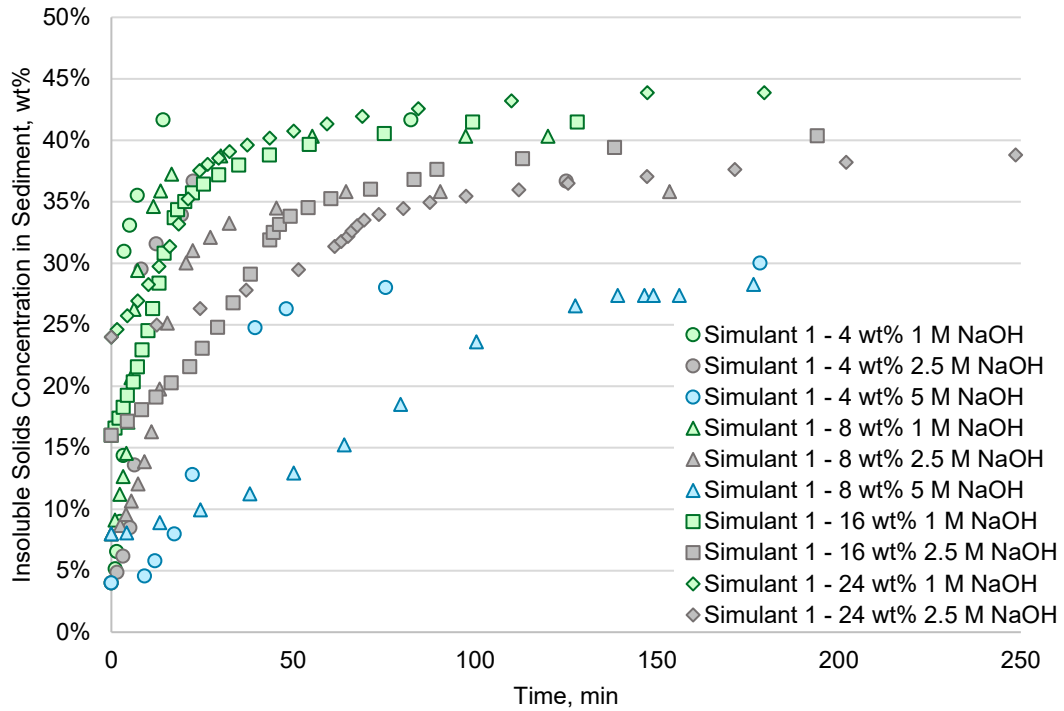

Figure 7 Insoluble Solids Concentration for Simulant 1 (Iron Oxide and Boehmite)

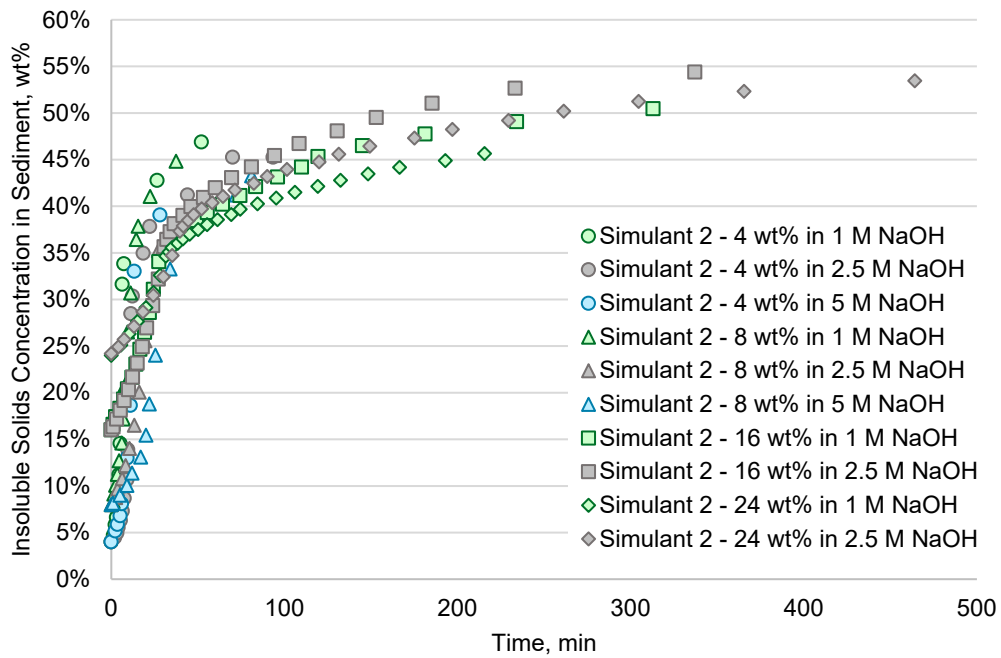

Figure 8 Insoluble Solids Concentration for Simulant 2 (Iron Oxide and Gibbsite)

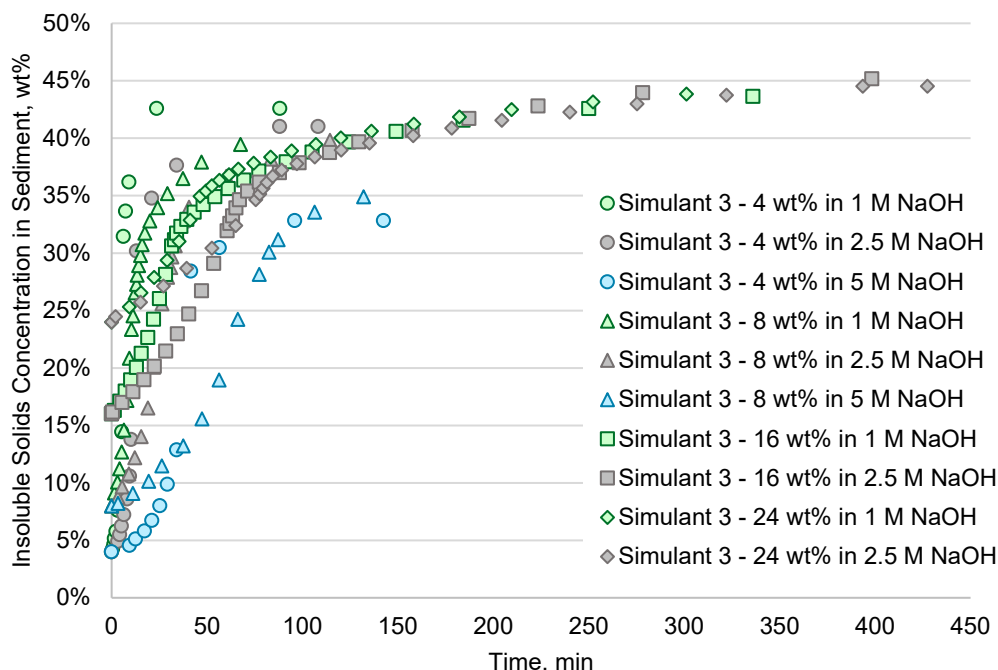

Figure 9 Insoluble Solids Concentration for Simulant 3 (Iron Oxide, Boehmite and Gibbsite)

3.1.2 Centrifuged Solids

The effective maximum solids concentration for each simulant was determined via centrifugation (5 minutes at 2000 RPMs). The average wt% centrifuged solids for Simulants 1, 2, and 3 were $49 \pm 3\%$, $67 \pm 8\%$, and $54 \pm 4\%$, respectively, of the total slurry mass. The centrifuged solids for individual measurements in each NaOH matrix are listed in Table 4. Results from the centrifuged solids measurements validate gravity settled solid behavior with a decrease in final wt% as a function of increasing NaOH concentration. However, in contrast to what would be expected, Simulant 2 experienced the highest of the centrifuged solids measurements but was consistently the lowest in gravity settling rates. In all slurries, the centrifuged solids measurement was nominally 10% greater than the maximum settled solids concentration.

Table 4 Simulant Centrifuged Solids Measurements, wt%

Slurry Feed	1 M NaOH	2.5 M NaOH	5 M NaOH
Simulant 1- Iron Oxide and Boehmite	$52.2 \pm 0.0\%$	$48.7 \pm 2.3\%$	$46.8 \pm 2.3\%$
Simulant 2 – Iron Oxide and Gibbsite	$70.9 \pm 4.7\%$	$72.2 \pm 0.0\%$	$58.0 \pm 0.0\%$
Simulant 3 – Iron Oxide, Boehmite, and Gibbsite	$57.1 \pm 2.9\%$	$55.6 \pm 0.0\%$	$49.6 \pm 0.0\%$

3.1.3 Particle Size Distribution (PSD)

Figure 10 presents the particle size distribution (PSD) plots of the slurries on a volume-weighted basis. Each point represents the percentage of total slurry with particle size less than or equal to the given diameter. The plots indicate that in all three slurries, the particles or agglomerates are less than 300 microns in diameter. A summary of the particle sizes, on a volume-weighted basis, is presented in Table 5. The slower settling rate of Simulant 2 may be directly related to the small size of the particles.

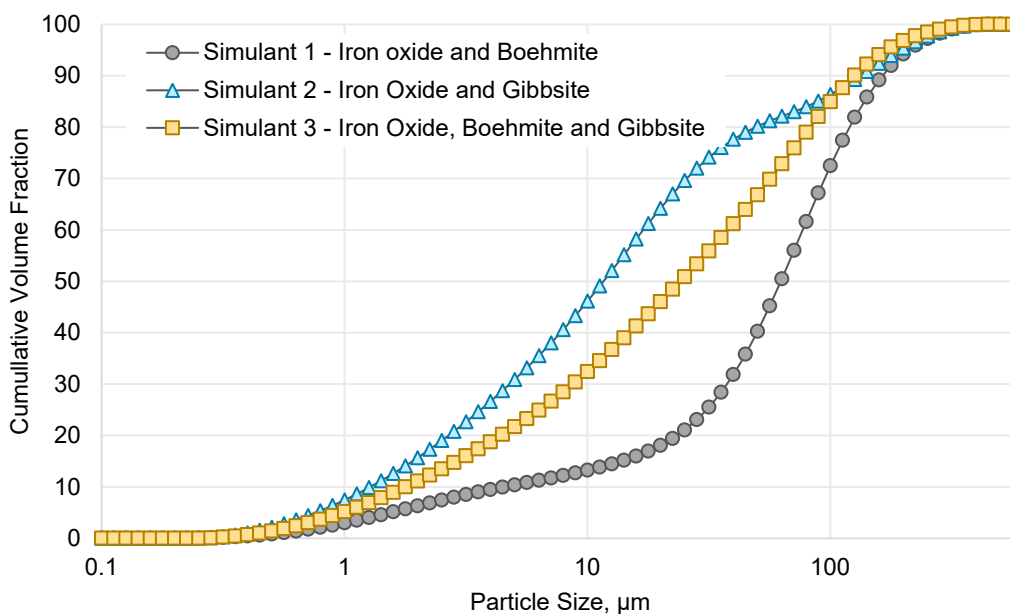

Figure 10 PSD of Slurries on a Volume-Weighted Bases for Simulants 1, 2, and 3 in Cumulative Under-Size-Percentage Distribution

Table 5 Summary of Cumulative Under-Size-Percentage Distribution and Mean Volume-Weighted Distribution for Simulants 1, 2, and 3

Slurry Feed	10 Percentile (microns)	50 Percentile (microns)	90 Percentile (microns)	Mean Volume (microns)
Simulant 1- Iron Oxide and Boehmite	11.54	67.96	161.07	63.24
Simulant 2 – Iron Oxide and Gibbsite	1.30	32.04	90.85	11.25
Simulant 3 – Iron Oxide, Boehmite, and Gibbsite	6.86	41.01	100.94	25.17

3.2 Crossflow Filtration

A summary table of the crossflow filtration test conditions are shown in Table 6. The impact of washing the slurry from 5 M NaOH to 1 M NaOH is seen through an increase in both filter flux and centrifuged solids concentration for all three slurry feeds. Decreasing Na molarity in the feed decreases viscosity of the solution thereby increasing filter flux. The permeate flowrates through the system required no correction for temperature because the temperature remained constant at 21 ± 2 °C throughout all phases of testing. All solutions started at a nominal 8 wt% insoluble solids and concentrated up to 20 wt% in order to collect sufficient data to develop a linear flux decline relationship with increasing solids concentration. In contrast to gravity settling, Simulant 2 experienced the highest permeate flowrates despite also having the highest centrifuged solids measurements. This is due to a lack of cake formation on the filter surface throughout the duration of testing.

Table 6 Summary of Crossflow Filtration Results for Simulants 1, 2, and 3

Process Parameter	Simulant 1- Iron Oxide and Boehmite			Simulant 2 – Iron Oxide and Gibbsite			Simulant 3 – Iron Oxide, Boehmite, and Gibbsite		
	5	2.5	1	5	2.5	1	5	2.5	1
NaOH Concentration, M	5	2.5	1	5	2.5	1	5	2.5	1
Initial Solids Concentration, wt %	8.0	8.0	8.1	8.0	8.0	8.2	6.7	6.7	6.7
Final Solids Concentration, wt %	19.8	18.6	18.8	20.0	22.9	26.4	15.7	15.6	19.1
Centrifuged Solids, wt %	47	49	52	58	72	71	50	56	57
Avg TMP, psig	18.2	15.1	16.4	15.7	11.0	18.4	21.1	18.7	19.8
Permeate Density, g/mL	1.15	1.08	1.04	1.15	1.09	1.05	1.18	1.08	1.04
Slurry Temperature, °C	22.6	21.4	21.3	18.3	18.3	19.0	20.4	20.6	23.9
Max Permeate Flow, mL/min	66.0	62.1	91.9	82.1	169.9	315.5	78.5	115.9	125.1
Min Permeate Flow, mL/min	25.7	3.0	42.5	3.2	48.7	114.2	29.0	24.0	44.4

Centrifuged solids measurements served as the gel-point maximum for each simulant feed. This value, defined as the point where filter flux declines to zero, is plotted alongside the filter flux vs log wt% UDS in Figure 11 through Figure 13. Dashed lines connecting the initial permeate flow to the centrifuged solids measurement are included on each graph to define the cake-formation linear flow dependence regime. Each of the data sets shown started with a backpulse to remove any residual solids from the filter prior to dewatering operations. Simulant 2 did not operate in the cake-formation regime, appearing as a relatively horizontal line on the chart with increasing wt% UDS. This result suggests that the solids loadings were not close enough to the ultimate gel point for the concentration polarization limitation to govern the

filtration rate. Slurries 1 and 3 transitioned to the post-cake formation region quickly and showed excellent extrapolation to the gel-point maximum.

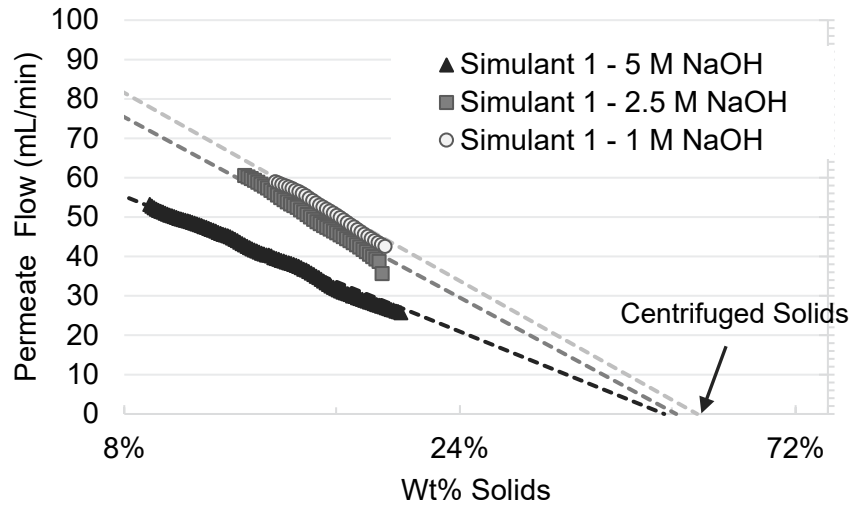

Figure 11 Dewatering of Simulant 1 from 8 wt% to 20 wt% in 1, 2.5 and 5 M NaOH including cake-formation linear flow dependence regime

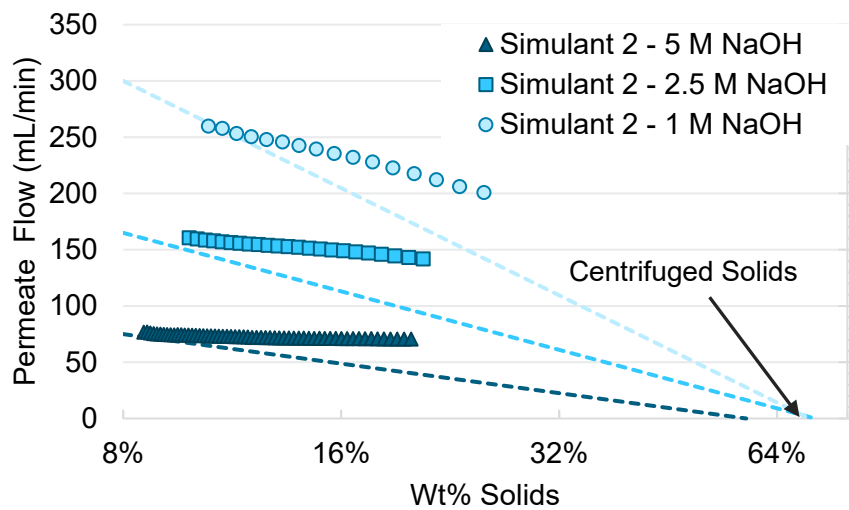

Figure 12 Dewatering of Simulant 2 from 8 wt% to 20 wt% in 1, 2.5 and 5 M NaOH including cake-formation linear flow dependence regime

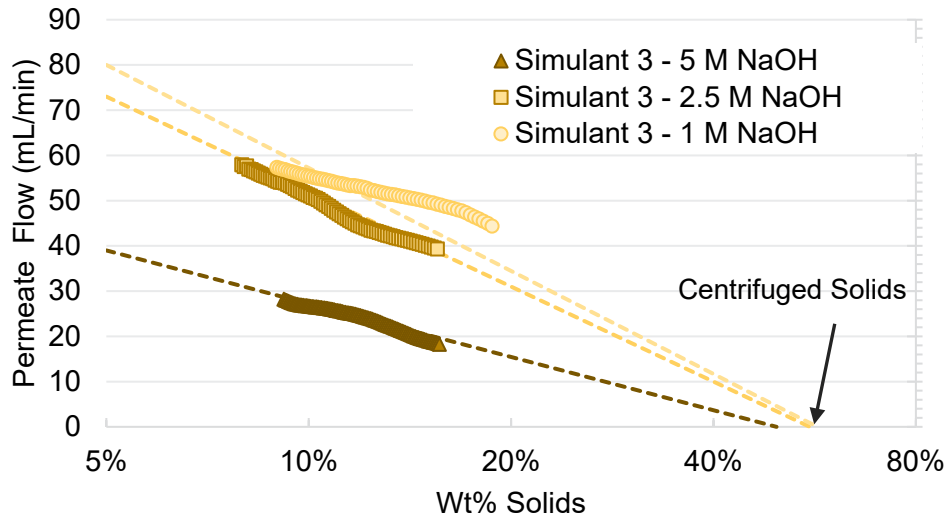

Figure 13 Dewatering of Simulant 3 from 8 wt% to 20 wt% in 1, 2.5 and 5 M NaOH including cake-formation linear flow dependence regime

4.0 Conclusions

As part HLW pretreatment processing evaluations, settling studies and crossflow filtration with Fe and various Al phases were conducted. Characterization of Hanford tank sludge shows Al and Fe make up the majority of prevalent metals in the waste solids, after Na. Red iron oxide was used as the Fe source and processing behaviors were examined in the presence of boehmite and gibbsite, two Al phases known to impact both settling and filtration. Three Na concentrations were used, 1, 2.5, and 5 M NaOH to bound tank conditions at potential process stages.

Gravity induced settling with solids concentrations less than 8 wt% were quickly settled within 30 minutes, while slurries with greater than 8 wt% solids concentrations required much longer times (1-3 hours) for complete settling. Solids generally settled as a single, distinct interface at initial rates ranging from 0.04 to 2.9 cm/min. These rates were significantly higher in 1 M NaOH interstitial solution matrices than in 5 M NaOH. The rate of compaction appeared to be strongly dependent on NaOH concentration. This relationship is due to changes in viscosity with increasing NaOH concentration, causing additional resistance to settling particles. Additionally, the final solids concentration in the sediment decreases as a function of increasing NaOH concentration. Simulant 2 experienced the slowest settling rates and may be directly related to the small size of the particles measured via PSD.

The effective maximum solids concentration for each simulant was determined via centrifugation. Centrifuged solids measurements were nominally 10% higher than what was seen from settling studies and confirmed settling behavior experiencing a decrease in final wt% as a function of increasing NaOH concentration.

Centrifuged solids measurements served as the crossflow filtration gel-point maximum for each simulant feed. Filtration feeds were dewatered from 8 wt% to 20 wt% in 5, 2.5 and 1 M NaOH. The impact of washing the slurry from 5 M NaOH to 1 M NaOH was seen through an increase in both filter flux and centrifuged solids concentration for all three slurry feeds. Simulant 2 did not operate in the cake-formation regime, appearing as a relatively horizontal line on the chart with increasing wt% UDS. This result suggests that the solids loadings were not close enough to the ultimate gel point for the concentration polarization limitation to govern the filtration rate. Slurries 1 and 3 transitioned to the post-cake formation region quickly and showed excellent extrapolation to the gel-point maximum.

Settling and/or filtration time estimates will be required for preliminary design of the HLW pretreatment process. Predictive methods for settling time and filtration performance will help enable process optimization to reach target feed solids concentration and assure pretreatment methods will be effective. This testing documents operational steps necessary for conducting centrifuged solids measurements and settling tests with HLW sludge samples. Repeatability of settling at varying Na concentrations and initial solids compositions bounds the behavior necessary for predicting overall sludge settling behavior. Settling measurements taken at a single condition are insufficient for representing waste samples outside of that composition. Additionally, consideration of centrifuged solids measurements will need to be accounted for when determining the best pretreatment flow path for varying tank chemistries as its impact on settling and filtration are contrasting. Although slurries described in the testing reported herein were selected to match HLW sludge chemistry, these components may not represent physical performance and additional work could focus on determining more representative Al and Fe phases.

5.0 References

Russell RL, DE Rinehart, JM Billing, HD Smith, and RA Peterson. 2009. *Development and Demonstration of Ultrafiltration Simulants*. PNNL-18090, WTP-RPT-183, Rev. 0, Pacific Northwest National Laboratory, Richland, Washington.

Tilanus SN, LM Bergmann, RO Lokken, AJ Schubick, EB West, RT Jasper, SL Orcutt, TM Holh, AN Praga, MN Wells, KW Burnett, CS Smalley, JK Bernards, D Reaksecker, and TL Waldo. 2017. *River Protection Project System Plan*. ORP-11242, Rev. 8, U.S. Department of Energy Office of River Protection, Richland, Washington.

Wells BE, RL Russell, LA Mahoney, GN Brown, DE Rinehart, WC Buchmiller, EC Golovich, and JV Crum. 2010. *Hanford Sludge Simulant Selection for Soil Mechanics Property Measurement*. PNNL-19250, Rev. 0. Pacific Northwest National Laboratory, Richland, Washington.

Wells BE, PA Gauglitz, LA Mahoney, and MS Fountain. 2020. *Technical Gaps in Hanford High-Level Waste Solids Settling Behavior and Settling Time Evaluation for Direct Feed High-Level Waste (DFHLW) Operations*. PNNL-30080, Rev. 0; RPT-OSIF-011, Rev. 0. Pacific Northwest National Laboratory, Richland, Washington.

Pacific Northwest National Laboratory

902 Battelle Boulevard
P.O. Box 999
Richland, WA 99354

1-888-375-PNNL (7665)

www.pnnl.gov