



BNL-224791-2023-TECH

EIC-ADD-TN-068

Preliminary Shielding Analysis for the 1012 400 MeV Linac Building

C. Schaefer

September 2023

Electron-Ion Collider
Brookhaven National Laboratory

U.S. Department of Energy
USDOE Office of Science (SC), Nuclear Physics (NP) (SC-26)

Notice: This technical note has been authored by employees of Brookhaven Science Associates, LLC under Contract No. DE-SC0012704 with the U.S. Department of Energy. The publisher by accepting the technical note for publication acknowledges that the United States Government retains a non-exclusive, paid-up, irrevocable, world-wide license to publish or reproduce the published form of this technical note, or allow others to do so, for United States Government purposes.

DISCLAIMER

This report was prepared as an account of work sponsored by an agency of the United States Government. Neither the United States Government nor any agency thereof, nor any of their employees, nor any of their contractors, subcontractors, or their employees, makes any warranty, express or implied, or assumes any legal liability or responsibility for the accuracy, completeness, or any third party's use or the results of such use of any information, apparatus, product, or process disclosed, or represents that its use would not infringe privately owned rights. Reference herein to any specific commercial product, process, or service by trade name, trademark, manufacturer, or otherwise, does not necessarily constitute or imply its endorsement, recommendation, or favoring by the United States Government or any agency thereof or its contractors or subcontractors. The views and opinions of authors expressed herein do not necessarily state or reflect those of the United States Government or any agency thereof.

EIC TECHNICAL NOTE
BROOKHAVEN NATIONAL LABORATORY

AUTHORS: C. Schaefer

DATE: September 2023

TITLE: Preliminary Shielding Analysis for the 1012 400 MeV Linac Building

1. Introduction

EIC is planning to purchase a 400 MeV turnkey pre-injector linear accelerator (Linac) which will be in a new building at the end of an existing RHIC tunnel at 12 o'clock. The building will contain the Linac Tunnel and associated accelerating structures, Klystron Gallery and waveguides, laser, utility, and control rooms. This report only examines the radiation source term produced by operating the Linac and not supplemental shielding that may be required to shield the Klystrons or solid state amplifiers in the Klystron Gallery from the x rays they emit.

Normal Portland concrete blocks are planned to provide shielding between the Linac vault and the occupiable portions of the building per the attached drawing. It is expected that this facility will not be routinely occupied during operations (post commissioning). The shielding design considers EIC's draft Shielding Policy that states shielding and other controls for areas where access is controlled for radiological purposes will be designed so that an ambient dose of 100 mrem per year to a worker is not likely.

2. Approach

EIC performed Monte Carlo radiation transport simulations using FLUKA and documented the results in a formal report (see attachment one). The FLUKA code is a fully integrated Monte Carlo simulation package for the interaction and transport of particles and nuclei in matter. The FLUKA model was developed from the preliminary building drawing and the beam source was provided by E. Wang. The thicknesses of the internal concrete shield walls between the accelerator and the occupiable spaces outside the accelerator vault were varied to help determine a shield design that satisfies EIC's draft shielding policy. Additional details are provided in the attached 400 MeV Linac at IR12 Preliminary FLUKA Report.

3. Assumptions

- This is a preliminary shielding report. It is assumed that some portions of the building structure used in the analysis may change as the design matures.
- Component dimensions and distances are as per revision A of drawing number 2011M0138 (see attachment two).
- Beam loss is 1% of maximum output or 0.56 nano-amps (nA).
- The density of Portland concrete is assumed to be 2.3 g cm^{-3} .
- The concrete shield walls between the Linac and the occupiable areas of the building are assumed to reach from the floor to the ceiling and are continuous.
- Soil density is assumed to be 1.6 g cm^{-3} .

4. Shielding Recommendations

Concrete Shield Walls

It is recommended to construct the concrete radiation shield walls as per the dimensions provided in revision A of drawing number 2011M0138 (attached). Individual stacked concrete blocks should be used. These are readily available to EIC. This shielding configuration meets the design objectives of EIC's draft Shielding Policy. Expected on-contact dose rates at the concrete shield wall are expected to be $\leq 1 \mu\text{Rem/h}$ above the local background. Penetrations should be angled and packed with supplemental shielding materials (e.g., steel, etc.).

Roof Shielding

The simulated dose rates on the roof are up to ~ 10 mrem/hour with an average of a few mrem/hour. EIC is planning to control access to the roof by using fencing and locked gates. From a radiation exposure perspective, one must consider not only exposure to BNL staff but also to the public. Building 1012 is only 270 meters from the site boundary, and radiation skyshine estimates using NCRP-151 methodology show that annual doses of 0.1 – 1 mrem are possible assuming 5000 hours of 400 MeV Linac operation annually.

The BNL Radiological Control Manual requires that radiation exposures to members of the public off-site shall not exceed 5 mrem in one year from the normal operation of any one single facility. The 5 mrem in one year limit applies to all EIC facilities collectively, not just Building 1012. Consequently, it is desirable to reduce the building 1012 skyshine estimate by a factor of ten using roof shielding.

Figure 1 below shows the effect on simulated dose rate as a function of concrete wall thickness. The red line is for the utilities, control, and laser rooms where the primary concrete wall will be constructed, and the blue line is for the downstream portion of the support building. The distance from the accelerator beam pipe to the roof is 14 feet, and the distance from the beam pipe to the inner surface of the vertical concrete shield wall at the Utilities room is 14.2 feet. The similarity in geometry allows use of the plot to estimate roof shielding without any corrections for distance. From Figure 1 it is seen that 25 cm (10 inches) of concrete provides an initial reduction in dose rate of about two orders of magnitude. Five (5) inches of light concrete or equivalent mass thickness of steel roof shielding will be sufficient to achieve the reduction in skyshine doses required.

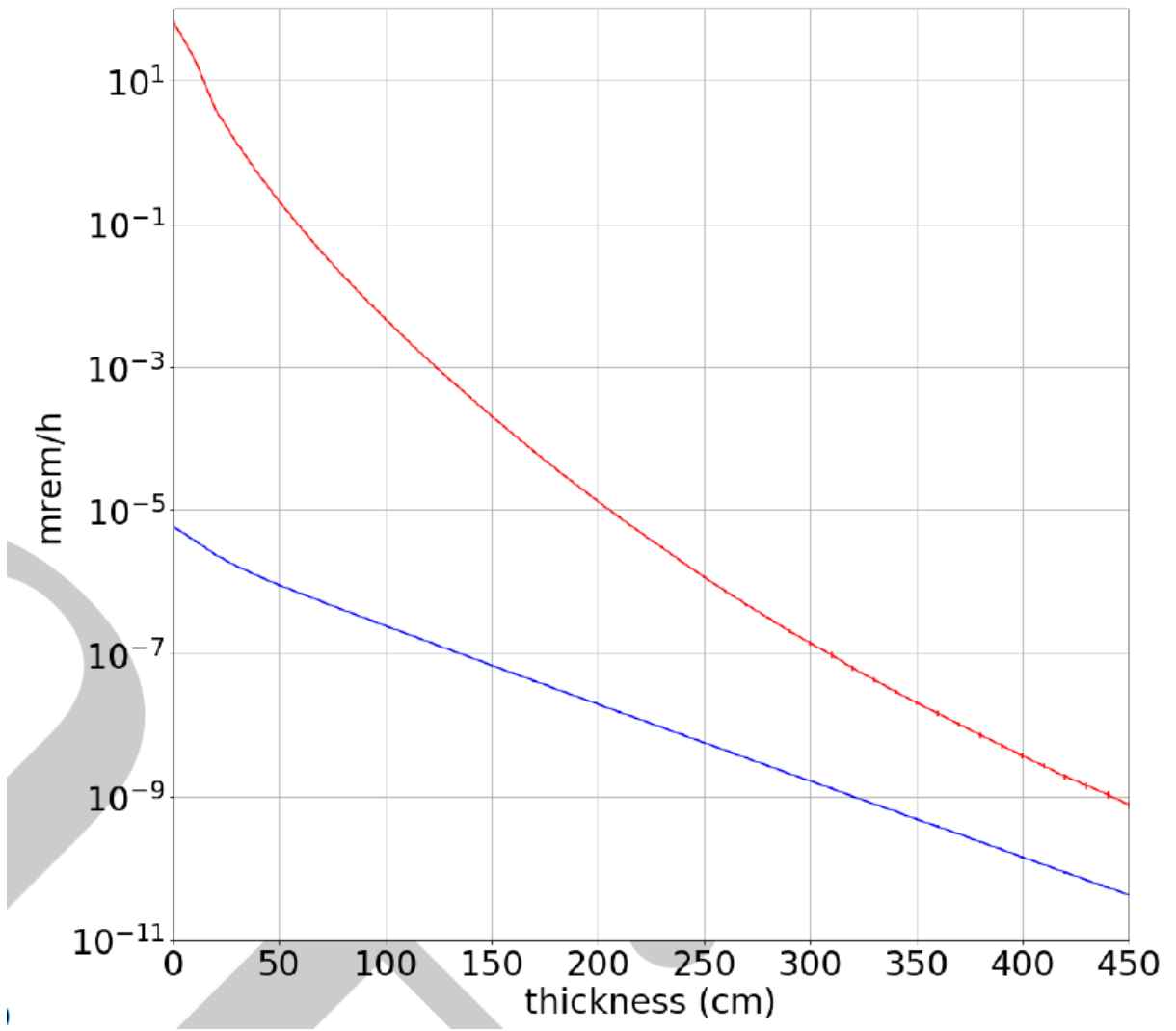

Figure 1 - mrem/hour profiles across the concrete walls of the utilities room and the support building

Outer Building Shielding

The shielding between the outside of the building and the RHIC tunnel may consist of either an extension of the soil berm or concrete wall shielding. The thickness should be equivalent to the 48 inches of light concrete between the accelerator and the utilities room and extend as close to the roof (18 feet from tunnel floor) as is achievable but not less than two-thirds of the building height.

Attachments

1. M. Chin. *400 MeV linac at IR12: Preliminary FLUKA simulation*, January 2023
2. Collider-Accelerator Drawing No. 2011M0138, Rev. A, May 2022

400 MeV linac at IR12: Preliminary FLUKA simulation

Radiation transport is simulated stochastically to inform building design of the support building, utility room, control room, laser room and pump room south of the 400 MeV linac. No conservative margin has been applied; conservative margins are left to the decision makers.

I. UPDATE (SEP 6): INTERNAL REVIEW & TIMELINE

Jan 20: Mary sent this report to Lori Stiegler, Chuck Schaefer, Angelika Drees, John Skaritka, Kevin Smith, Joe Tuozzolo and Erdong Wang, suggesting a group discussion on input parameters which were changing since November.

Feb 6: Lori scheduled a group meeting for Feb 22, inviting Ricardo dos Santos Augusto and Mo Benmerrouche as reviewers.

Feb 14: Lori cancelled the scheduled meeting, passing to Chuck.

Feb 14: Mary sought Ricardo's review over Teams. Ricardo pointed out a truncated plot, finding no issue, "some low statistics but they do not affect the conclusion". Mary explained that stats were necessarily so, as simulations were killed and restarted with changed inputs every few days since November, and this report was for the group to discuss over – to converge on inputs.

Mar 1: Mary sought review from Mo over a Teams call. Mo suggested that a different fluence-to-dose conversion be used, and thicker averaging slices.

Mar 24: Mary reported to Chuck over a Teams call the reviews by Ricardo and Mo.

Aug 18: Infrastructure called for a meeting, which advised that Chuck should apply occupancy factors and author a technical note based on this report.

II. BEAM ANGLE

A beam angle of 20° with respect to the beam axis is considered. This is understood from Erdong to be the worst case. For a vacuum chamber of radius 1.415 cm , by simple trigonometry the beam would hit the beampipe 4 cm downstream. The beam effectively takes the shape of a conic surface, reaching for the beampipe from the beam axis for its first collision with matter (Fig. 1).

III. BEAM LOSS

Beam loss is translated for simulation by taking 1% of 56 nA beam current. All of the 0.56 nA , distributed uniformly along the beamline, hits the beampipe as described in preceding section. That is, only loss particles are simulated.

IV. BEAM ENERGY

Increasing electron energy from zero to 400 MeV along the $\approx 50\text{ m}$ beamline is simulated by downsampling Erdong's Parmela output to 27 cm intervals (Fig. 2).

One could have and typically would have simulated just 400 MeV electrons, invoking the catch-all name of *conservative estimation*. That is how nearly the whole world is over-shielded.

V. GEOMETRY AND COMPOSITION

Geometry is provided in a STEP file by Vito. Most materials are stainless steel; some others are copper. All walls are Portland concrete of density 2.3 g cm^{-3} . Soil composition is as provided to PK Job by BNL Environmental and Waste Management Services Division; soil density 1.6 g cm^{-3} is understood to be representative of Long Island[1]. This value is lower than the NCRP *low-density soil* of 1.7 g cm^{-3} [2].

Space outside Vito's model is filled with soil (west, north, east, above and below) and air (south). In the simulation all walls go right up to the ceiling, which is 4.572 m from the floor. Maintaining the in-side of Vito's walls, walls are simulated thicker than given, so that decisions may be made by scissor-trimming the walls to the \dot{H} of choice. With the \dot{H} contours as guidance, the support building, utility room, control room, laser room and pump room may be carved out.

VI. AMBIENT DOSE EQUIVALENT

Ambient dose equivalent (\dot{H}) is estimated by FLUKA 4-3.1 [3], [4] simulations, where mix-field fluences of stochastically-simulated tracks are converted to dose equivalents [5], [6]. Via latching[7], components contributing towards \dot{H} are broken down to:

- Streaming down the 6 tubes running from the top of the tunnel to the support building; the particle or at least one of its ancestors has been in at least one of the tubes.
- Scattering down the labyrinth southeast; the particle or at least one of its ancestors has been in the labyrinth.

\dot{H} maps (Fig. 3 to Fig. 7) are plotted on three sections: a horizontal section and a vertical section around the beam axis, averaged over $\pm 1\text{ m}$ in the third dimension, and a horizontal section around the tubes running from the top of the tunnel to the support building, averaged over $\pm 51\text{ cm}$ in the third dimension.

LIST OF FIGURES

1	Fluence (cm^{-2}) per primary electron before any inelastic collision: sections co-planar (left) and perpendicular (right) to the beam axis, averaged over $\pm 1\text{ cm}$ and 10 m in the third dimension, respectively.	3
2	Section-by-section energy gain along eight linac sections. Energy is downsampled from Er-dong's Parmela simulation and used as input for radiation-transport simulation; downsampling effects are not visible on this scale. Beamline and built environment are from Vito.	4
3	Total $\dot{H}(mrem/h)$ in the horizontal section $\pm 1\text{ m}$ around beam axis: \dot{H} (left) and the corresponding % error (right). Axes mark Cartesian coordinates in cm . Bin dimensions are $10\text{ cm} \times 10\text{ cm}$	5
4	Total $\dot{H}(mrem/h)$ in the horizontal section $\pm 1\text{ m}$ around the tunnel-to-support tubes: \dot{H} (left) and the corresponding % error (right). Axes mark Cartesian coordinates in cm . Bin dimensions are $10\text{ cm} \times 10\text{ cm}$	6
5	Total $\dot{H}(mrem/h)$ in the vertical section $\pm 1\text{ m}$ around beam axis: \dot{H} (left) and the corresponding % error (right). Axes mark Cartesian coordinates in cm . Bin dimensions are $10\text{ cm} \times 10\text{ cm}$	7
6	Tunnel-to-support-streaming component in the horizontal section $\pm 1\text{ m}$ around the tunnel-to-support tubes: \dot{H} (left) and the corresponding % error (right). Axes mark Cartesian coordinates in cm . Bin dimensions are $10\text{ cm} \times 10\text{ cm}$. Blank pixels appearing white indicate neither zero \dot{H} nor zero error.	8
7	Labyrinth-scatter component in the horizontal section $\pm 1\text{ m}$ around beam axis: \dot{H} (left) and the corresponding % error (right). Axes mark Cartesian coordinates in cm . Bin dimensions are $10\text{ cm} \times 10\text{ cm}$. Blank pixels appearing white indicate neither zero \dot{H} nor zero error.	9

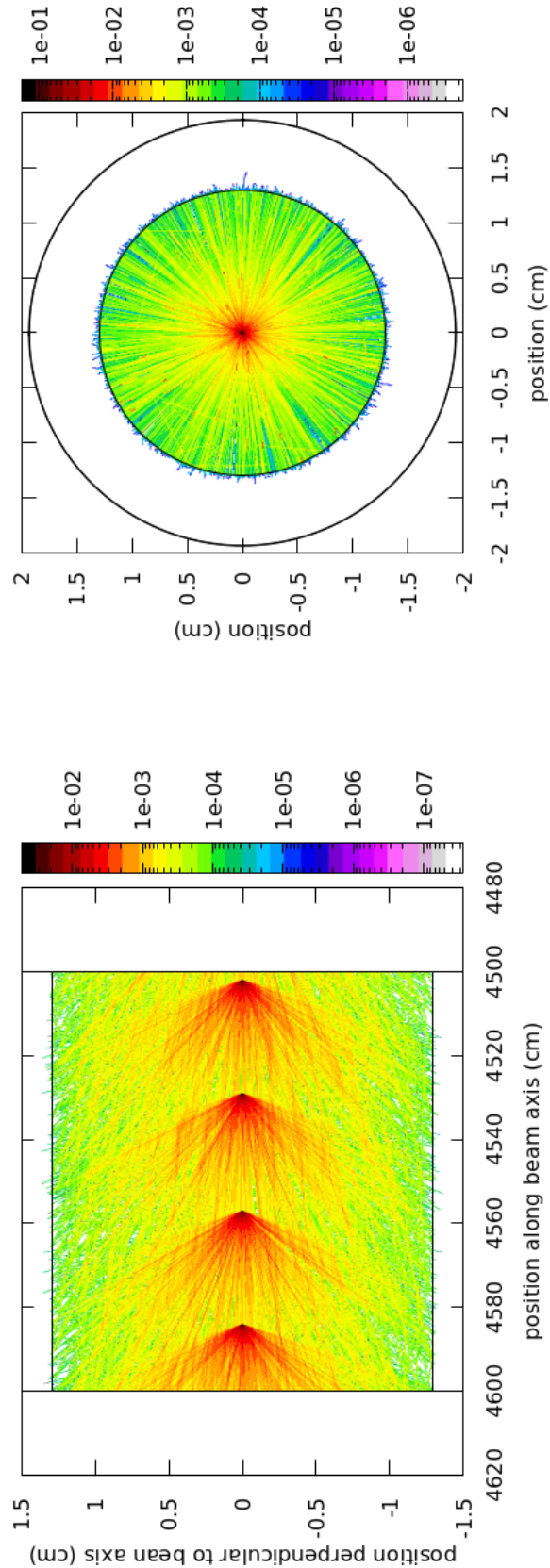

Fig. 1: Fluence (cm^{-2}) per primary electron before any inelastic collision: sections co-planar (left) and perpendicular (right) to the beam axis, averaged over $\pm 1\text{ cm}$ and 10 m in the third dimension, respectively.

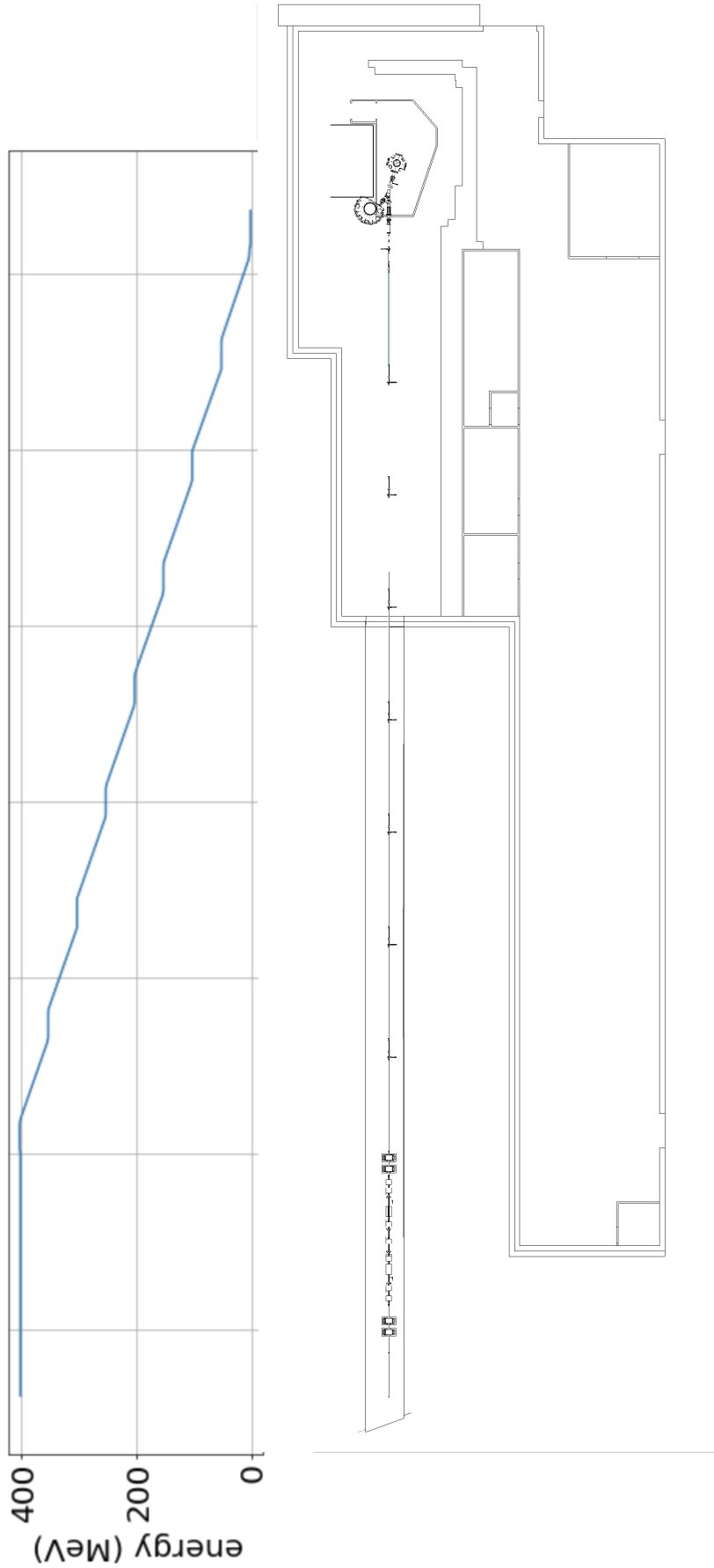

Fig. 2: Section-by-section energy gain along eight linac sections. Energy is downsampled from Erdong's Parmela simulation and used as input for radiation-transport simulation; downsampling effects are not visible on this scale. Beamline and built environment are from Vito.

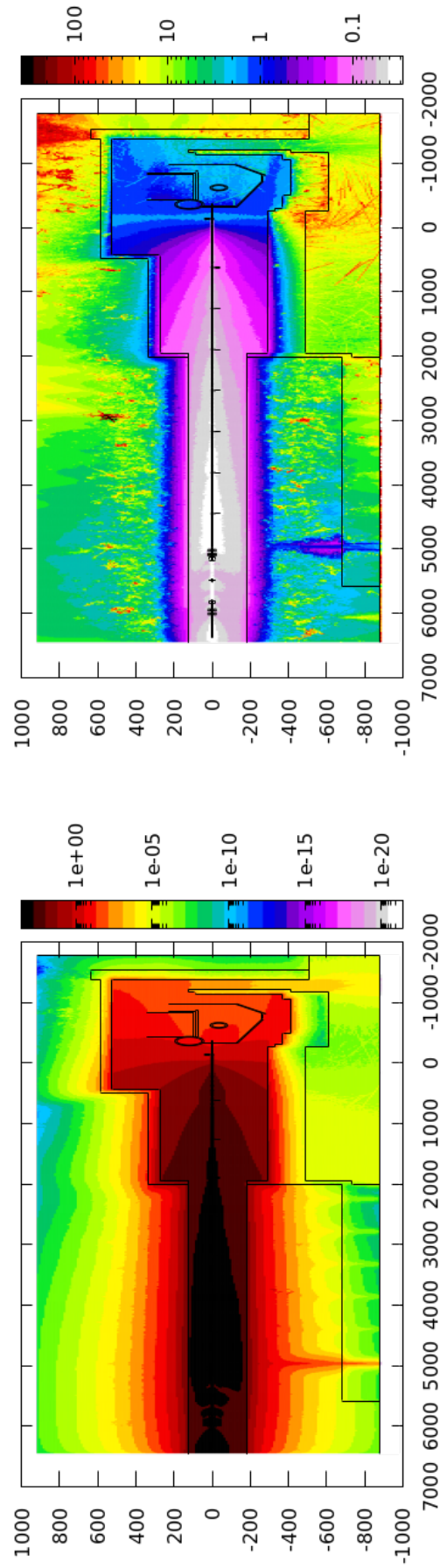

Fig. 3: Total $\dot{H}(mrem/h)$ in the horizontal section $\pm 1 m$ around beam axis: \dot{H} (left) and the corresponding % error (right). Axes mark Cartesian coordinates in cm . Bin dimensions are $10 cm \times 10 cm$.

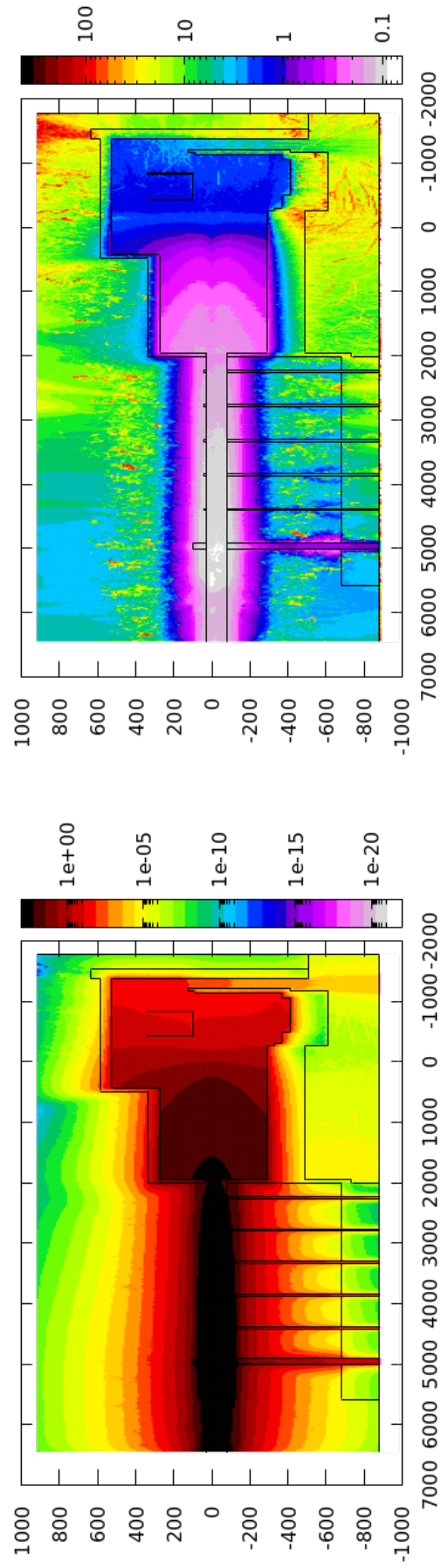

Fig. 4: Total $\dot{H}(mrem/h)$ in the horizontal section $\pm 1 m$ around the tunnel-to-support tubes: \dot{H} (left) and the corresponding % error (right). Axes mark Cartesian coordinates in cm . Bin dimensions are $10 cm \times 10 cm$.

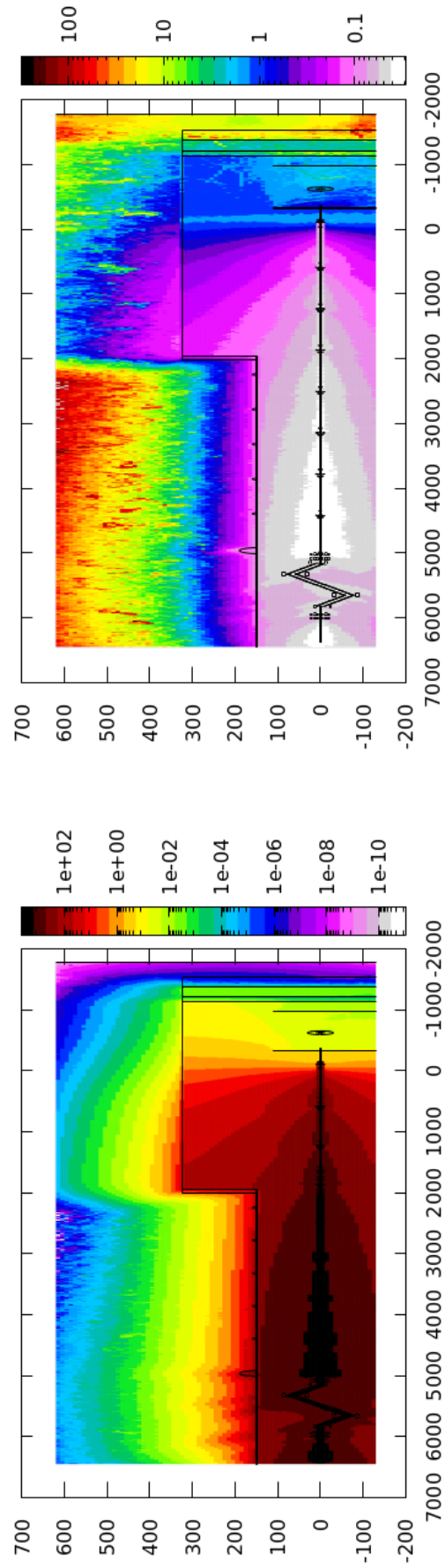

Fig. 5: Total \dot{H} ($mrem/h$) in the vertical section $\pm 1 m$ around beam axis: \dot{H} (left) and the corresponding % error (right). Axes mark Cartesian coordinates in cm . Bin dimensions are $10 cm \times 10 cm$.

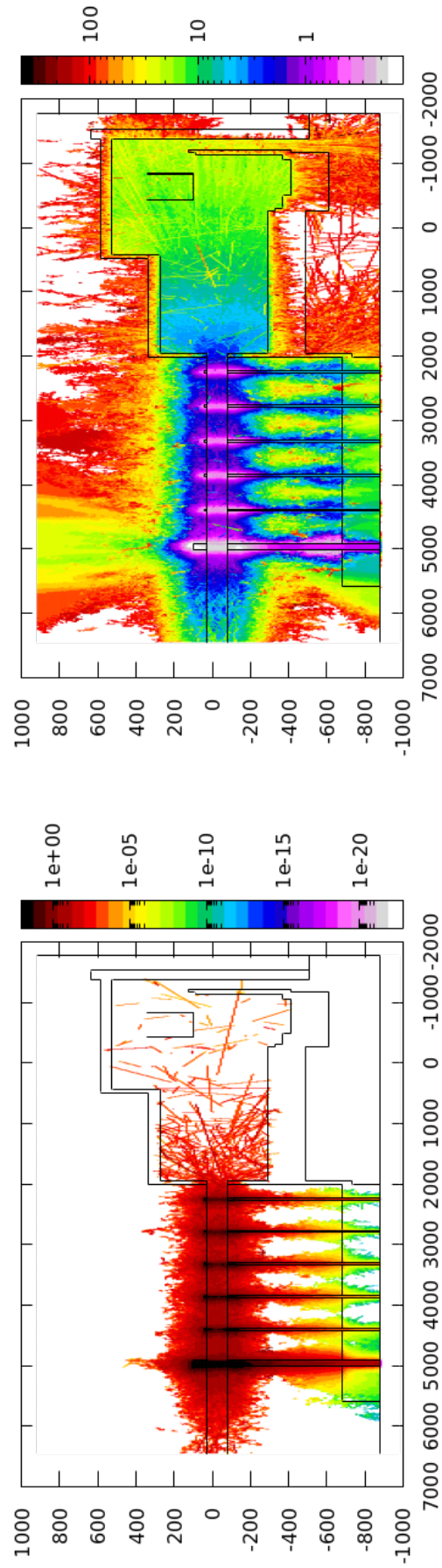

Fig. 6: Tunnel-to-support-streaming component in the horizontal section $\pm 1 m$ around the tunnel-to-support tubes: \dot{H} (left) and the corresponding % error (right). Axes mark Cartesian coordinates in cm . Bin dimensions are $10 cm \times 10 cm$. Blank pixels appearing white indicate neither zero \dot{H} nor zero error.

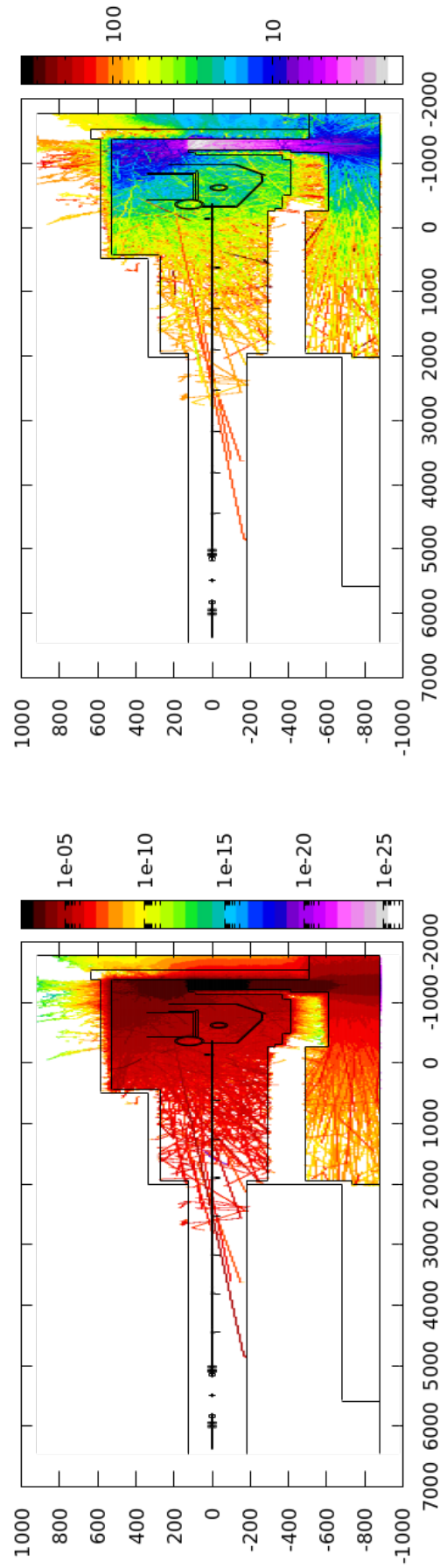

Fig. 7: Labyrinth-scatter component in the horizontal section $\pm 1 m$ around beam axis: \dot{H} (left) and the corresponding % error (right). Axes mark Cartesian coordinates in cm . Bin dimensions are $10 cm \times 10 cm$. Blank pixels appearing white indicate neither zero \dot{H} nor zero error.

REFERENCES

- [1] P. K. Job and W. R. Casey, “Activation analysis of soil, air and water near the NSLS-II accelerator enclosures,” *NSLS-II Technical Note*, 2008.
- [2] NCRP, “NCRP Report No. 144: radiation protection for particle accelerator facilities,” *National Council on Radiation Protection and Measurements*, 2005.
- [3] G. Battistoni, T. Böhlen, F. Cerutti, M. P. W. Chin, L. S. Esposito, A. Fassò, A. Ferrari, A. Lechner, A. Empl, A. Mairani, A. Mereghetti, P. G. Ortega, J. Ranft, S. Roesler, P. R. Sala, V. Vlachoudis, and G. Smirnov”, “Overview of the FLUKA code,” *Annals of Nuclear Energy*, vol. 82, pp. 10–18, 2015.
- [4] C. Ahdida, D. Bozzato, D. Calzolari, F. Cerutti, N. Charitonidis, A. Cimmino, A. Coronetti, G. L. D’Alessandro, A. Donadon Servelle, L. S. Esposito, R. Froeschl, R. García Alfa, A. Gerbershagen, S. Gilardoni, D. Horváth, G. Hugo, A. Infantino, V. Kouskoura, A. Lechner, B. Lefebvre, G. Lerner, M. Magistris, A. Manousos, G. Moryc, F. Ogallar Ruiz, F. Pozzi, D. Prelicpean, S. Roesler, R. Rossi, M. Sabaté Gilarte, F. Salvat Pujol, P. Schoofs, V. Stránský, C. Theis, A. Tsinganis, R. Versaci, V. Vlachoudis, A. Waets, and M. Widorski, “New capabilities of the FLUKA multi-purpose code,” *Frontiers in Physics*, vol. 9, pp. Art.–Nr.: 788 253, 2022.
- [5] ICRP, “Conversion coefficients for use in radiological protection against external radiation;” vol. ICRP Publication 74, 1996.
- [6] M. Pelliccioni, “Overview of fluence-to-effective dose and fluence-to-ambient dose equivalent conversion coefficients for high energy radiation calculated using the FLUKA code,” *Radiation Protection Dosimetry*, vol. 88, pp. 279–297, 2000.
- [7] M. P. W. Chin, F. Cerutti, A. Ferrari, P. Garcia Ortega, and P. R. Sala, “Monte Carlo latching studies of prompt-gamma detection during hadrontherapy,” *IEEE Transactions on Nuclear Science*, vol. 61, no. 5, pp. 2540–46, 2014.

REVISION APPROVALS						
REV	EDN NO.	DESCRIPTION	DATE	BY	CHK	SUPV
1		INITIAL RELEASE				

NOTES:

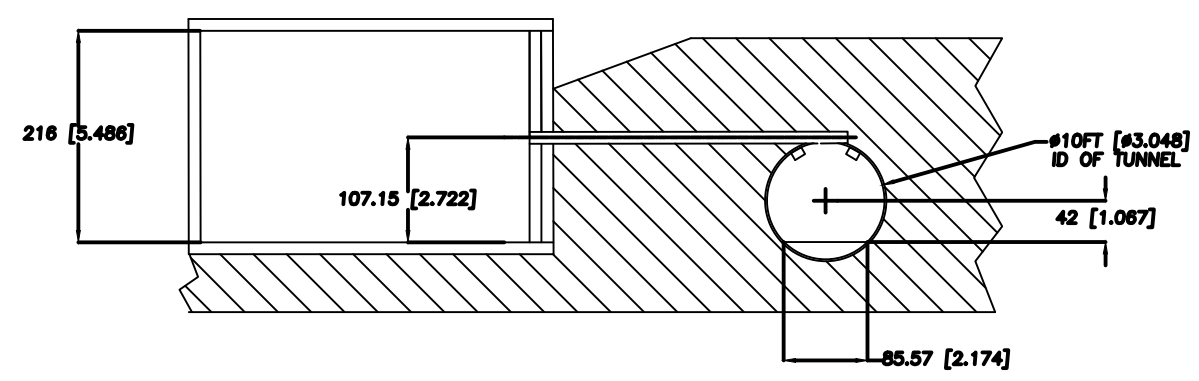
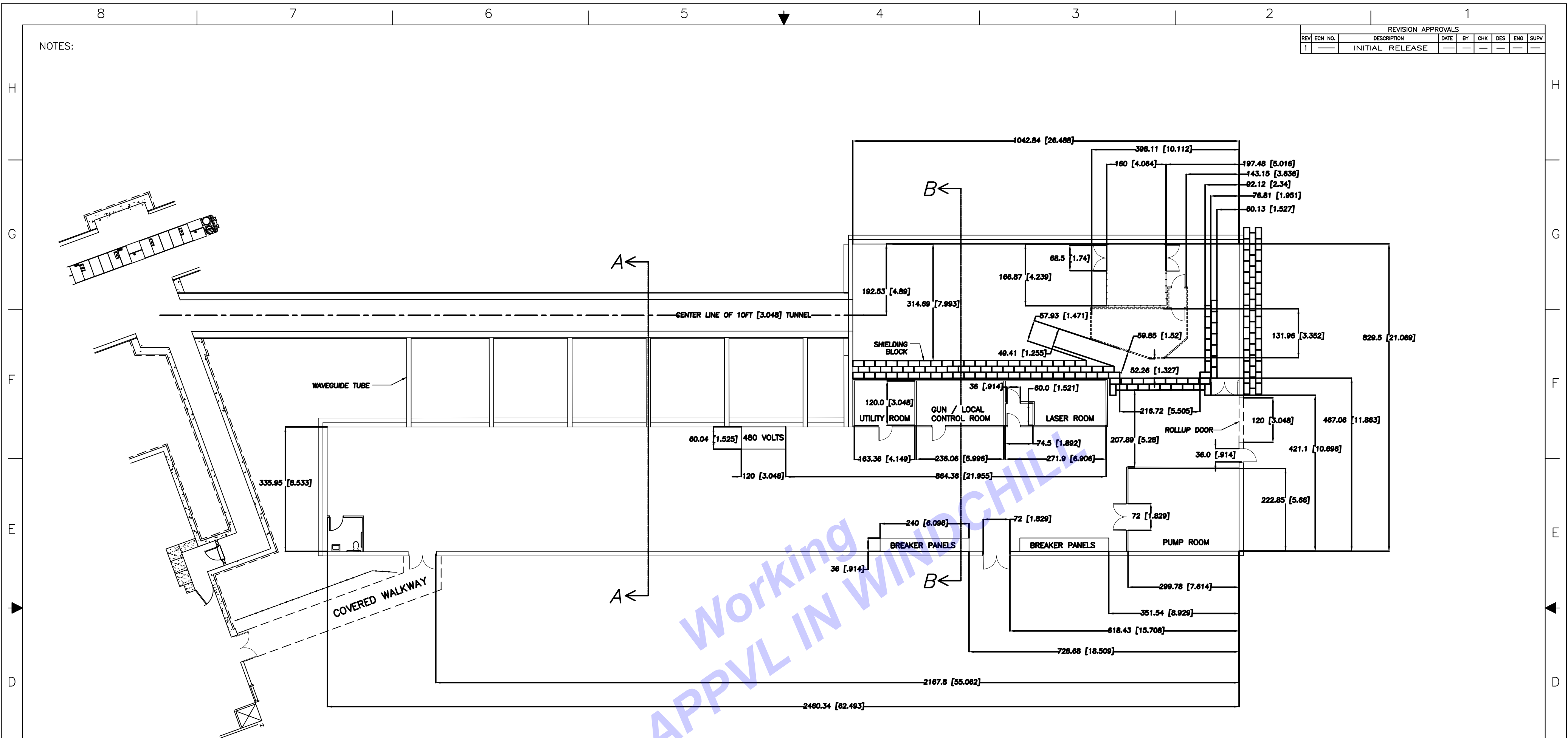

SECTION A-A
VIEW ROTATED 90° CLOCKWISE

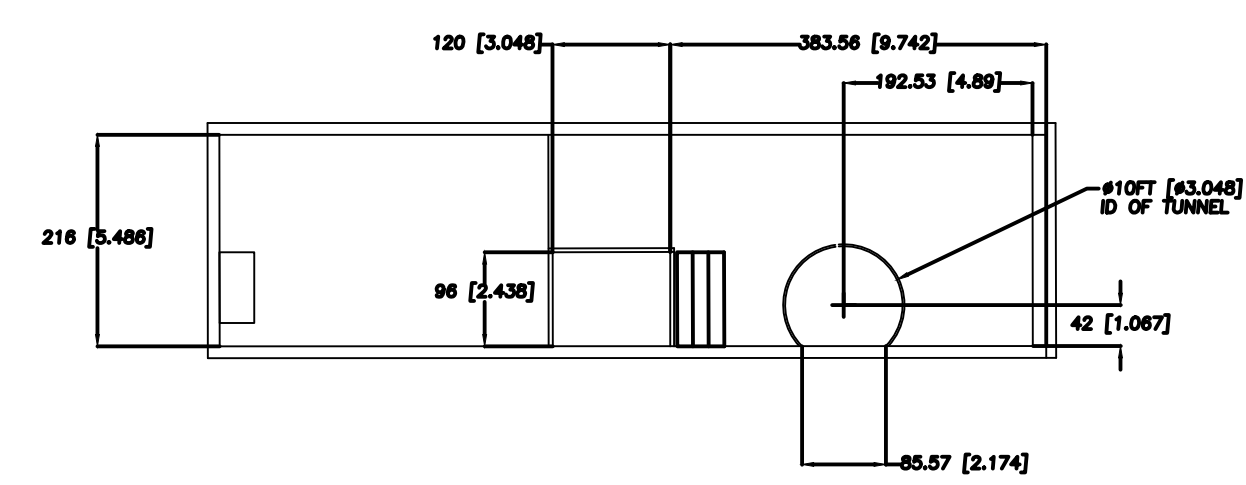

SECTION B-B
VIEW ROTATED 90° CLOCKWISE

PRELIMINARY

INTERPRET IN GENERAL ACCORDANCE WITH ASME Y14.5 UNLESS OTHERWISE SPECIFIED DIMENSIONS ARE IN INCHES DECIMAL TOLERANCES: .125 & .250 ± .010 .001 & .015 ± .002 ANGULAR TOLERANCES ± 1°		V DEMONTE 5/12/22 J SKARTIKA 5/24/22		COLLIDER-ACCELERATOR DEPARTMENT BROOKHAVEN NATIONAL LABORATORY UPTON, N.Y. 11973 TITLE: EIC 400MeV TURN KEY LINAC PROCUREMENT BLDG. LAYOUT	
USED ON DRAWING NO. QTY. PER ASSY. APPLICATION: FINISH	125 / BREAK SHARP EDGES MAX. .03 MIN. .015	SIZE: E CATEGORY: A3	DRAWING NUMBER: 2011M0138 REV: A	SCALE: 1/8"=1'-0" SHEET: 1 OF 3	AUTOCAD

DWG NO 2011M0138 SH 1 OF 3 A

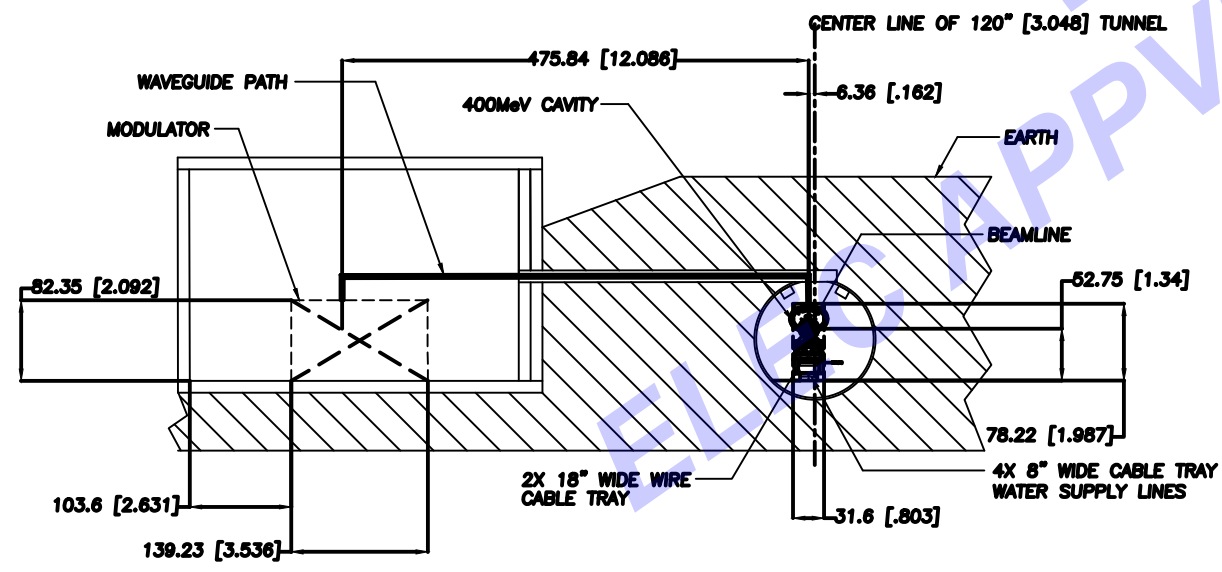
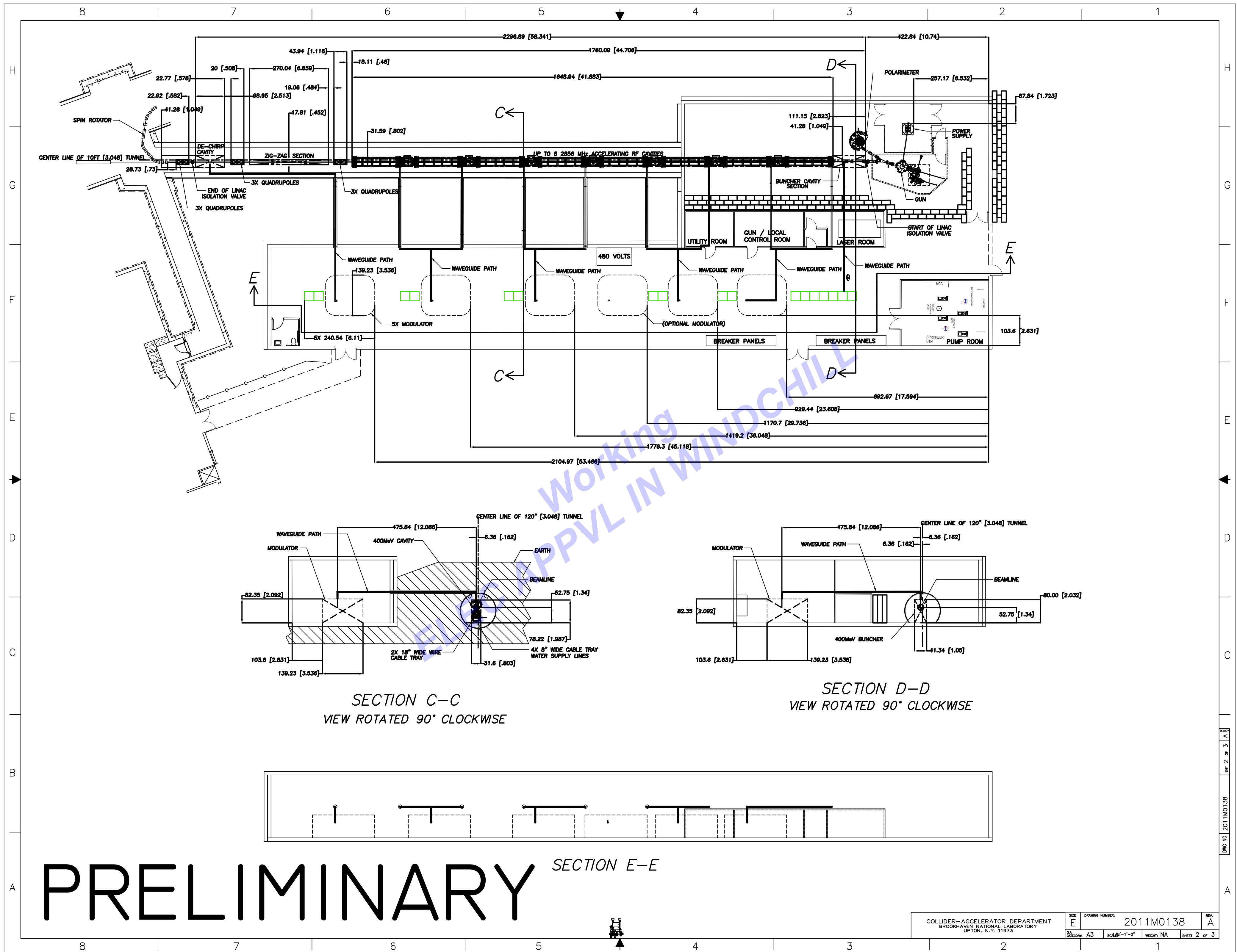

SECTION C-C
VIEW ROTATED 90° CLOCKWISE

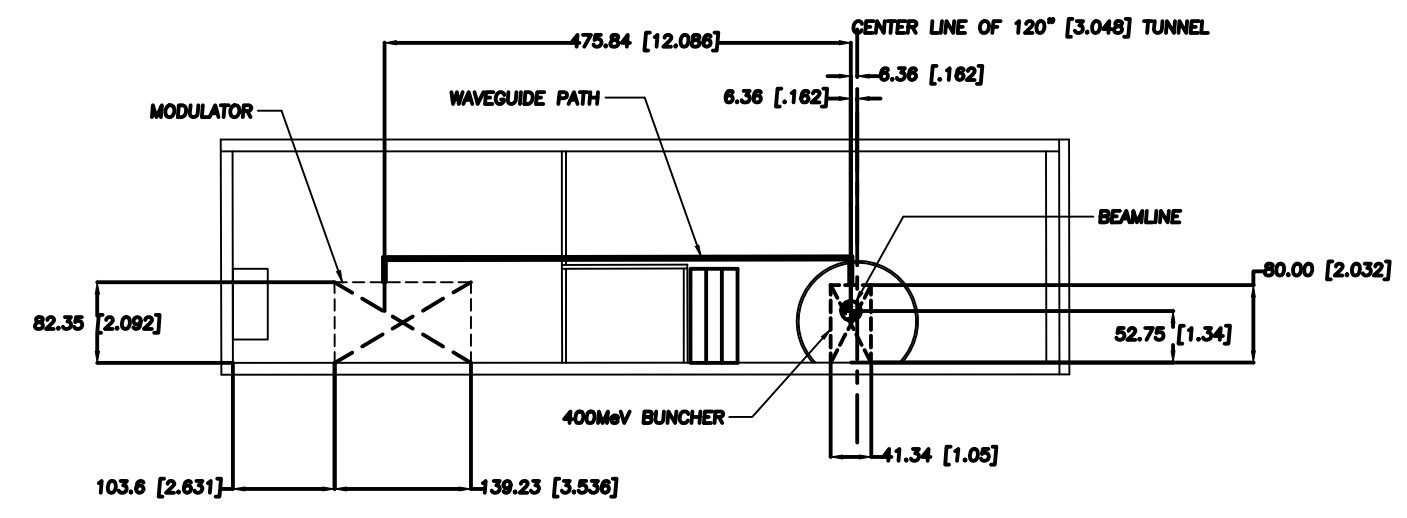

SECTION D-D
VIEW ROTATED 90° CLOCKWISE

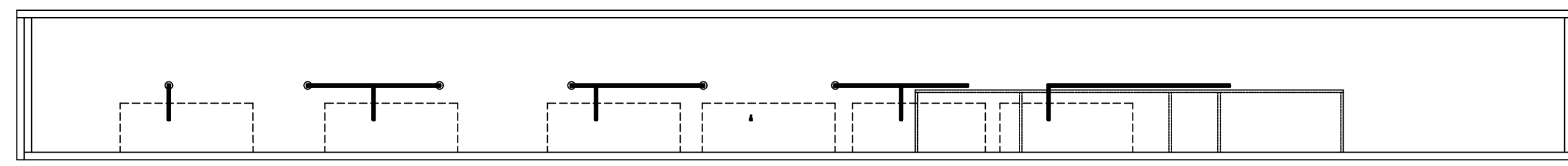

SECTION E-E

PRELIMINARY

COLLIDER-ACCELERATOR DEPARTMENT		SIZE	DRAWING NUMBER	REV.
BROOKHAVEN NATIONAL LABORATORY		E	2011M0138	A
LIFTON, N.Y. 11973		SCALE	1"=10'	
CAT. NO.	A3	WEIGHT	NA	SHEET 2 OF 3

DWG NO 2011M0138
SHEET 2 OF 3

PRELIMINARY

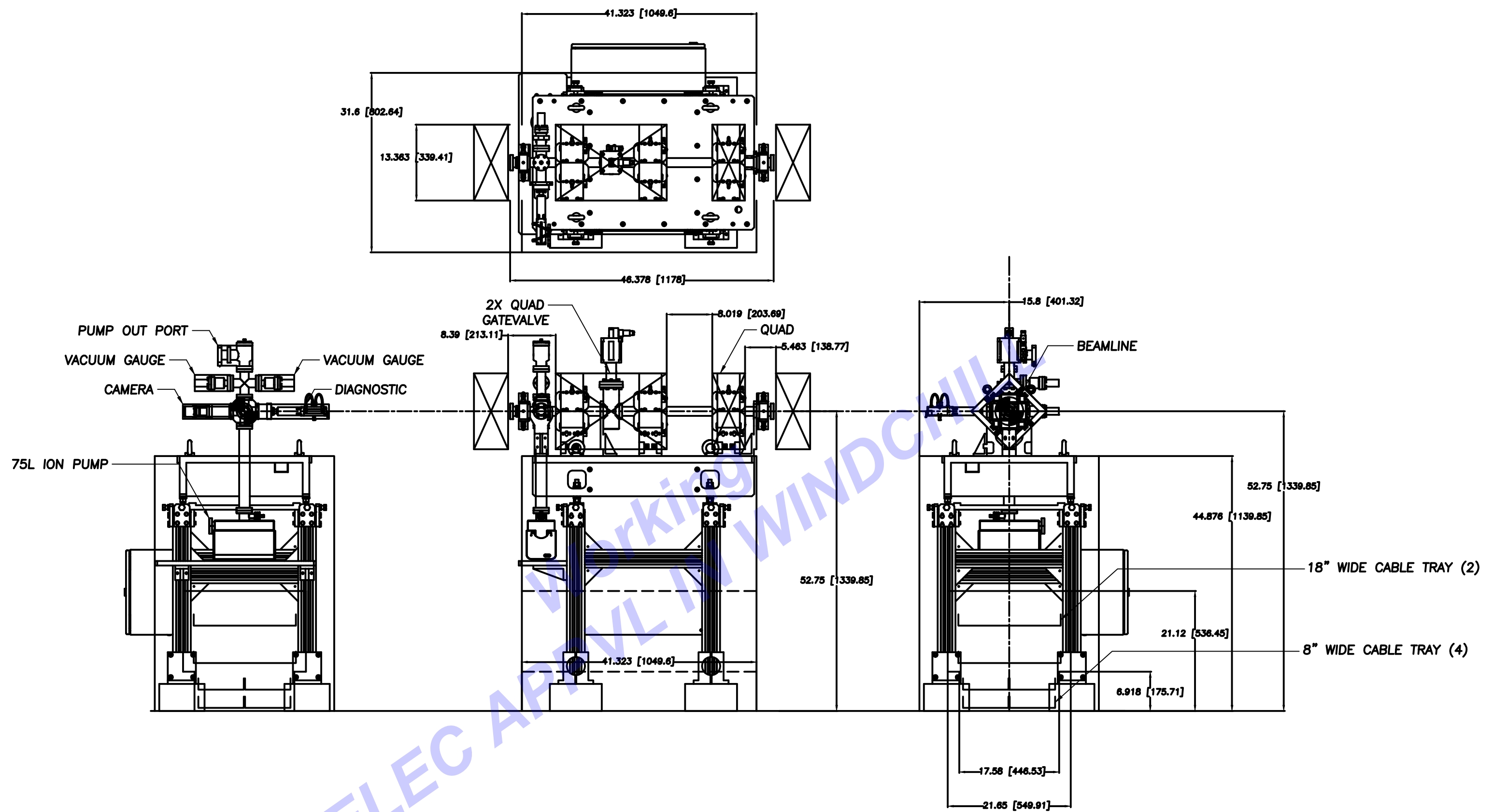

QUADRUPOLE ASSEMBLY