

# Advanced Measurements for Resilient Integration of Inverter-Based Resources

## PROGRESS MATRIX Year-1 Report

**March 2023**

JD Follum	K Mahapatra
R Hovsopian	A Riepnieks
NM Stenvig	AJ Wilson
Y Agalgaonkar	S Chanda
K Chatterjee	S Granda



## DISCLAIMER

This report was prepared as an account of work sponsored by an agency of the United States Government. Neither the United States Government nor any agency thereof, nor Battelle Memorial Institute, nor any of their employees, makes **any warranty, express or implied, or assumes any legal liability or responsibility for the accuracy, completeness, or usefulness of any information, apparatus, product, or process disclosed, or represents that its use would not infringe privately owned rights**. Reference herein to any specific commercial product, process, or service by trade name, trademark, manufacturer, or otherwise does not necessarily constitute or imply its endorsement, recommendation, or favoring by the United States Government or any agency thereof, or Battelle Memorial Institute. The views and opinions of authors expressed herein do not necessarily state or reflect those of the United States Government or any agency thereof.

PACIFIC NORTHWEST NATIONAL LABORATORY

*operated by*

BATTELLE

*for the*

UNITED STATES DEPARTMENT OF ENERGY

*under Contract DE-AC05-76RL01830*

Printed in the United States of America

Available to DOE and DOE contractors from the  
Office of Scientific and Technical Information,  
P.O. Box 62, Oak Ridge, TN 37831-0062;  
ph: (865) 576-8401  
fax: (865) 576-5728  
email: [reports@adonis.osti.gov](mailto:reports@adonis.osti.gov)

Available to the public from the National Technical Information Service  
5301 Shawnee Rd., Alexandria, VA 22312  
ph: (800) 553-NTIS (6847)  
email: [orders@ntis.gov](mailto:orders@ntis.gov) <<https://www.ntis.gov/about>>  
Online ordering: <http://www.ntis.gov>



# Advanced Measurements for Resilient Integration of Inverter- Based Resources

PROGRESS MATRIX Year-1 Report

JD Follum<sup>1</sup>  
R Hovsapian<sup>2</sup>  
NM Stenvig<sup>3</sup>  
Y Agalgaonkar<sup>2</sup>  
K Chatterjee<sup>1</sup>

K Mahapatra<sup>1</sup>  
A Riepnieks<sup>1</sup>  
AJ Wilson<sup>3</sup>  
S Chandra<sup>2</sup>  
S Granda<sup>2</sup>

March 2023

---

<sup>1</sup> PNNL  
<sup>2</sup> NREL  
<sup>3</sup> ORNL



## Abstract

As nearly every aspect of the electric power grid undergoes rapid change, measurement technologies that support grid operation and planning must evolve as well. Recent large-scale deployments of inverter-based resources (IBRs) have brought to the forefront the critical need for new measurement technologies. Though these IBRs are vital to achieving the nation's clean energy goals, their rapid deployment has in some cases led to negative impacts on the reliability and security of the bulk power system (BPS). Advanced power system measurements, including synchronized phasor and waveform measurements, are key to making IBR integration secure and reliable. To this end, the Department of Energy (DOE) initiated a project in 2022 to develop advanced measurement capabilities and analytics that will accelerate adoption of IBRs while improving the reliability and resilience of the BPS. This report discusses a portion of the findings from the project's first year, which focused on surveying existing measurement capabilities of partner utilities and comparing these capabilities with the requirements of applications that support IBR integration. This report also discusses how these findings will guide the development and demonstration of a set of applications in the project's second year.



## Acknowledgments

The authors gratefully acknowledge Marissa Morales-Rodriguez of DOE's Office of Energy Efficiency and Renewable Energy (EERE), Solar Energy Technology Office (SETO) and Sandra Jenkins of DOE's Office of Electricity, Transmission Reliability and Renewables Integration program for their helpful insight and funding support. We are also grateful to the Bonneville Power Administration (BPA), Kaua'i Island Utility Cooperative (KIUC), and the Western Area Power Administration (WAPA) for providing information about measurement systems and measurements to support further research. In particular, we would like to thank Tony Faris, Elliott Mitchell-Colgan, and Steve Yang at BPA; the engineering staff at KIUC; and Sean Erickson, Joshua Moyers, Jodi Jensen, Michael Logan Pokallus, and Scott Johnson at WAPA. Finally, we thank our colleagues Jason MacDonald, Kristina LaCommare, and Sascha von Meier of Lawrence Berkeley National Laboratory (LBNL) and Alex McEachern at McEachern Labs for their contributions on aspects of the project not reported in this document and their helpful discussions throughout the past year.



## Acronyms and Abbreviations

AI/ML	Artificial Intelligence and Machine Learning
BESS	Battery Energy Storage System
BPA	Bonneville Power Administration
DER	Distributed Energy Resource
DFR	Digital Fault Recorder
DOE	Department of Energy
GPS	Global Positioning System
IBR	Inverter-Based Resource
KIUC	Kaua'i Island Utility Cooperative
LBNL	Lawrence Berkeley National Laboratory
NREL	National Renewable Energy Laboratory
ORNL	Oak Ridge National Laboratory
PDC	Phasor Data Concentrator
PLL	Phase-Locked Loop
PMU	Phasor Measurement Unit
PNNL	Pacific Northwest National Laboratory
POC	Point of Connection
POI	Point of Interconnection
POM	Point of Measurement
PV	Photovoltaic
RMS	Root Mean Square
ROCOF	Rate-of-Change-of-Frequency
SSO	Subsynchronous Oscillation
TS	Transmission System
UGA	Universal Grid Analyzer
WAPA	Western Area Power Administration



# Contents

Abstract .....	iii
Acknowledgments.....	v
Acronyms and Abbreviations .....	vii
1.0 Introduction .....	1
2.0 BPA Gap Analysis.....	3
2.1 BPA’s Existing Measurement Capabilities .....	3
2.1.1 Synchrophasor Measurements from PMUs.....	3
2.1.2 Point-on-Wave Measurements from DFRs .....	4
2.2 Application Evaluation.....	5
2.2.1 Inertia Estimation from Ambient Data .....	6
2.2.2 Subsynchronous Oscillation (SSO) Source Localization .....	7
2.2.3 Disturbance Monitoring .....	8
2.2.4 Data-Driven Modeling for Stability and Control .....	10
2.2.5 Monitoring Support for Ride-Through Control Capability .....	11
2.2.6 Anti-Islanding Protection .....	12
2.2.7 Weak Grid Planning.....	13
2.3 PNNL’s Field Demonstration Plan .....	14
3.0 KIUC Gap Analysis.....	18
3.1 KIUC’s Existing Measurement Capabilities .....	18
3.1.1 Site-Specific Analysis .....	18
3.1.2 General High-Speed Measurement Capabilities at KIUC.....	19
3.2 Application Evaluation.....	20
3.2.1 Grid Frequency Characterization and Extreme Frequency Event Detection .....	20
3.2.2 IBR-Related High-Frequency Oscillation Detection and Modeling .....	21
3.2.3 Study of Higher-Frequency Grid Signatures.....	23
3.3 ORNL’s Live Demonstration Plan.....	24
4.0 WAPA Gap Analysis.....	26
4.1 WAPA’s Existing Measurement Capabilities Application Evaluation .....	26
4.1.1 Oscillation Detection and Mitigation .....	28
4.1.2 Disturbance Monitoring .....	29
4.1.3 Model Validation.....	29
4.2 NREL’s Live Demonstration Plan .....	30
4.2.1 NREL ARIES Facility.....	31
4.2.2 WAPA Data Archive.....	31
4.2.3 WAPA Data Streaming to DRTS.....	32
5.0 Research Gaps .....	35

6.0 Conclusion.....	36
7.0 Bibliography.....	37

# Figures

Figure 2-1. Conceptual diagram describing the terms POC, POM, POI. Adapted from IEEE 2800 Std (IEEE, 2022). .....	6
Figure 2-2. Conceptual illustration of the Generator Scorecard report for two generators. These diagrams are based on images shared by BPA. ....	16
Figure 2-3. Screen capture of the Archive Walker user interface showing the detection of an oscillation in PMU measurements. ....	17
Figure 4-1. WAPA customer service territory .....	26
Figure 4-2. Approximate locations of PMUs across the WAPA customer service territories.....	27
Figure 4-3. Notional IBR oscillation damping control architecture .....	29
Figure 4-4. Typical model validation process.....	30
Figure 4-5. NREL's ARIES Facility .....	31
Figure 4-6. WAPA raw data streaming to DRTS – database management .....	32
Figure 4-7. WAPA raw data streaming to DRTS leveraging OpenPDC .....	33
Figure 4-8. WECC reduced order mode and CHIL interface of the PMUs. ....	34

# Tables

Table 2-1. Specifications for BPA’s PMU system.....	4
Table 2-2. Specifications for BPA's DFR system.....	5
Table 2-3. Comparison of BPA’s measurement capabilities with the requirements of the inertia estimation application.....	7
Table 2-4. Comparison of BPA’s measurement capabilities with the requirements of the subsynchronous oscillation source localization application.....	8
Table 2-5. Comparison of BPA’s measurement capabilities with the requirements of the disturbance monitoring application.....	9
Table 2-6. Comparison of BPA’s measurement capabilities with the requirements of the data-driven modeling for stability and control application.....	10
Table 2-7. Comparison of BPA’s measurement capabilities with the requirements of the monitoring support for ride-through control capability application.....	12
Table 2-8. Comparison of BPA’s measurement capabilities with the requirements of anti-islanding protection application.....	13
Table 2-9. Comparison of BPA’s measurement capabilities with the requirements of weak grid planning application.....	14
Table 3-1. Requirements for grid frequency characterization and measuring extreme frequency events..	21
Table 3-2. Requirements for measurement of high-frequency oscillations .....	22
Table 3-3. General requirements for POW measurements of IBR-related disturbances .....	24
Table 4-1. Measurement sensor infrastructure in DSW customer service region.....	27
Table 4-2. Measurement sensor infrastructure in RM & SN customer service region .....	27

# 1.0 Introduction

As nearly every aspect of the electric power grid undergoes rapid change, measurement technologies that support grid operation and planning must evolve as well. Recent large-scale deployments of inverter-based resources (IBRs) have brought to the forefront the critical need for new measurement technologies. Though these IBRs are vital to achieving the nation’s clean energy goals, their rapid deployment has in some cases led to negative impacts on the reliability and security of the bulk power system (BPS), as evidenced by the Blue Cut Fire and Canyon 2 Fire system disturbances. Advanced power system measurements capable of capturing the high-speed behaviors involved in these events, including synchronized phasor and waveform measurements, are key to making IBR integration secure and reliable.

Recognizing the need to investigate the role of advanced power system measurements in the integration of IBRs, the U.S. Department of Energy (DOE) funded the project Probing with GridSweep Electrical Sensing and Signals – Measurement, Analytics, and Testbeds for Resilient Integration and eXamination of IBRs (PROGRESS MATRIX). The project is a joint effort among Pacific Northwest National Laboratory (PNNL), Oak Ridge National Laboratory (ORNL), National Renewable Energy Laboratory (NREL), and Lawrence Berkeley National Laboratory (LBNL). The overall objective of the project is to develop advanced measurement capabilities and analytics that will accelerate adoption of IBRs while improving the reliability and resilience of the BPS. This report discusses results from one portion of the project’s first year.

Specifically, this report discusses the survey of partner utilities’ measurement capabilities and evaluation of IBR related applications performed by PNNL, ORNL, and NREL. For the survey, PNNL partnered with the Bonneville Power Administration (BPA), ORNL worked with Kaua‘i Island Utility Cooperative (KIUC), and NREL partnered with the Western Area Power Administration (WAPA). The laboratories worked with these utilities to understand the types of sensors deployed at IBR sites within their territory. Of particular interest were synchrophasor measurements available from phasor measurement units (PMUs) and point-on-wave (POW)<sup>1</sup> measurements from digital fault/disturbance recorders (DFRs/DDRs), power quality meters, and merging units. The team also investigated communication channels for retrieving the data, formats for storing data, and limitations on aggregating data from different sources.

Information about utility measurement capabilities was critical in evaluating the potential of measurement-based applications intended to support IBR integration. The concepts for these applications were collected from literature reviews and generated by the laboratory team in collaboration with partner utilities. For each application, requirements such as sample rate, reporting rate, record duration, bandwidth limitations of signal-processing algorithms, and triggering conditions were documented. The application requirements were then compared against the measurement capabilities of partner utilities to identify gaps limiting the deployment of the applications. In the long term, this information will be useful to the utilities as they continue to integrate IBRs and invest in their measurement infrastructure. In the near term, the findings will guide the development and demonstration of a set of applications in the project’s second year.

The details of the outcomes from the project’s first year are provided in the following three chapters, with each chapter covering the work of a laboratory coordinating with a utility partner. The chapters are

---

<sup>1</sup> In this report, unless otherwise mentioned, POW refers to time-synchronized point-on-wave measurements. The data derived from multiple channels of a single sensor is by default synchronized. For wide-area synchronization of multiple sensors, global positioning system (GPS) or network time protocol (NTP) time-synchronization may be adopted.

structured similarly, and each includes a discussion of the partner utility's measurement capabilities, results from application evaluations, and plans for a demonstration in the project's second year. Chapter 2.0 discusses PNNL's work with BPA, which led to a plan for a field demonstration of a PMU-driven application to monitor the performance of power plants. ORNL's work with KIUC to compare instrument capabilities with application requirements is presented in Chapter 3.0, as is ORNL's plan to demonstrate the frequency-based characterization and event detection application with their testbed. WAPA's measurement capabilities and applications of interest to NREL are presented in Chapter 4.0. For their demonstration, NREL plans to demonstrate the oscillation mitigation, model validation and disturbance monitoring application using their Advanced Research on Integrated Energy Systems (ARIES) testbed. The report concludes with a discussion of high-level research gaps in Chapter 5.0 and a review of findings and plans for future work in Chapter 6.0.

## 2.0 BPA Gap Analysis

This chapter compares the data acquisition and reporting capabilities of BPA's measurement systems with those required by the IBR-related applications shortlisted by PNNL in Section 2.2. For each of these applications, the gap between the existing infrastructure and the prerequisites for an online and/or offline field demonstration at BPA are identified. The gap analysis helped in shortlisting a few potential applications for demonstration from a long list of IBR applications initially compiled based on a literature review. An overview of BPA's existing measurement capabilities is presented next.

### 2.1 BPA's Existing Measurement Capabilities

BPA is a regional power marketing administration within the US DOE responsible for transmitting and selling wholesale electricity in the Pacific Northwest. It owns more than 15,000 miles of transmission lines and 261 substations, which accounts for approximately 75% of the high voltage transmission (230 kV and higher) capacity in the region (BPA, 2016).

In this analysis, both synchrophasor and waveform measurement capabilities at BPA are considered. The information about the measurement systems were gathered from publicly available BPA reports and presentations, and from conversations with BPA engineers.

While comparing BPA's capabilities in PMU- versus POW-based monitoring, the key point that arises is with respect to its readiness level in operationalizing these technologies. The existing data reporting infrastructure at BPA supports continuous streaming of PMU data at 60 frames/sec from the substations to control centers for online monitoring, but the same for higher resolution POW data is yet to be realized. The POW data, therefore, is stored locally at the substations and retrieved when needed. The finer details of the respective measurement systems are discussed next.

#### 2.1.1 Synchrophasor Measurements from PMUs

Depending on how the measured data from a PMU is utilized at its control center, BPA classifies its PMUs into two different types:

- 1) *Control PMUs*: data from these PMUs are suitable for use in real-time decision making. Applications include oscillation detection, mode metering, islanding detection, frequency event detection, state estimation, and remedial action scheme (RAS)-based wide-area control. These PMUs are critical to reliable operation of the system and therefore have redundancy and backup.

There are two sets of control PMUs at each critical location, each of which sends data to two different control centers. There is also an inter-control center link to route PMU data between the control centers, which serves as a backup to the direct communication between each control center and its primary PMU. Phasor data concentrators (PDCs) at each control center can switch from their primary to backup, if necessary, based on their PMU status word.

- 2) *Data PMUs*: data from these PMUs are only used in offline applications like post-event analysis and model validation.

The specifications of BPA's PMU system are listed in Table 2-1.

**Table 2-1. Specifications for BPA’s PMU system.**

<b>Reporting rate</b>	60 frames/s
<b>Sampling rate</b>	8 kHz
<b>Trigger</b>	No triggering; continuous recording
<b>Timing accuracy</b>	C37.118-2005 compliant; typically, better than 1 $\mu$ s
<b>Measurement redundancy</b>	Control PMUs fully redundant – 2PMUs at each location Data PMUs not redundant – only 1 PMU at each location
<b>Installations</b>	Control PMUs: 77 PMU pairs at 54 sites Data PMUs: 32 PMU pairs at 23 sites
<b>Communication system</b>	Dedicated fiber optic communication – SONET UDP multicast Encrypted at field and decrypted at control center
<b>Communication bandwidth</b>	256 kbps for installations with 1 PMU (Data PMU) Double for installations with 2 PMUs (Control PMUs)
<b>Latency</b>	Typically, tens of ms
<b>Archival</b>	OSIsoft PI; data stored in floating point format; minimal processing – no filtering and compression

The unfiltered raw synchrophasor data obtained from the field sensors is stored using OSIsoft PI. The control room applications extract this data using PI-based tools, and then using the retrieved data performs monitoring operations such as oscillation detection and frequency analysis and later writes the results (including the alarm statuses) back into PI. This operational archive has size limitations. Typically, BPA stores 6 months of operational data. In addition to this, BPA also hosts a 200 TB R&D-grade archive for long-term storage. The archive stores 4+ years of full-fidelity data from all BPA PMUs and WECC partners in *PDAT* format. This contains flat binary files with C37.118 configuration frame followed by one minute of data frame.

### **2.1.2 Point-on-Wave Measurements from DFRs**

BPA’s primary source of POW measurements is their set of digital fault recorders (DFRs). These DFRs are deployed with configurations compliant with the NERC PRC-002 standard. Based on the requirements of the standard, the specifications of BPA’s DFR system can be expected to meet or exceed the specifications in Table 2-2. BPA’s DFRs and PMUs sample data from same current and potential transformers.

**Table 2-2. Specifications for BPA's DFR system.**

<b>Measurements</b>	Phase to neutral voltage at each bus for each phase; Phase current for each phase and the neutral current for all (a) transmission lines connected to the bus, and (b) transformers with LV-side voltage 100 kV or above
<b>Triggered/continuous</b>	Trigger-based; not continuous
<b>Trigger settings</b>	At least one of the following: (a) neutral overcurrent  (b) phase undervoltage or overcurrent
<b>Recording rate</b>	At least 16 samples/cycle (960 samples/s)
<b>Record length</b>	Either of (a) 2 cycles of pre-trigger data and total record of 30 cycles for the same trigger, or (b) 2 cycles of pre-trigger data, first 3 cycles of post-trigger data, and the final cycle of the fault as seen by DFR
<b>Measurement redundancy</b>	None; only 1 DFR at each location
<b>Communication</b>	Connected over dedicated network
<b>Streaming</b>	Polling done when needed

## 2.2 Application Evaluation

This section describes a variety of applications related to operations and services associated with IBRs connected to the transmission system (TS). As indicated by the citations throughout the following subsections, the initial concepts for these applications were found in the literature. PNNL reviewed many other potential applications before down selecting to these seven as the highest value for a TS and realistic for implementation at utility premises. The application descriptions include the initial concepts found in the literature as well as novel ideas conceived by PNNL. After identifying these applications, PNNL worked with BPA to understand how well each application's measurement requirements aligned with BPA's measurement capabilities, specifically for the systems providing synchrophasor and POW measurements. The results of this review are presented in a table at the end of each subsection. When evaluating a measurement's required location, the terminology from IEEE 2800 standard (IEEE, 2022) is adopted. As illustrated in Figure 2-1, these terms are:

- Point of interconnection (POI): The point where the interconnection system connects an IBR to the TS.
- Point of measurement (POM): A point between the high-voltage bus of the IBR and the interconnection system (IEEE, 2022). In most cases, for the TS owner, POM can be at the POI.
- Point of connection (POC): The point where an IBR unit is electrically connected to a collector system, as specified by the IBR owner.

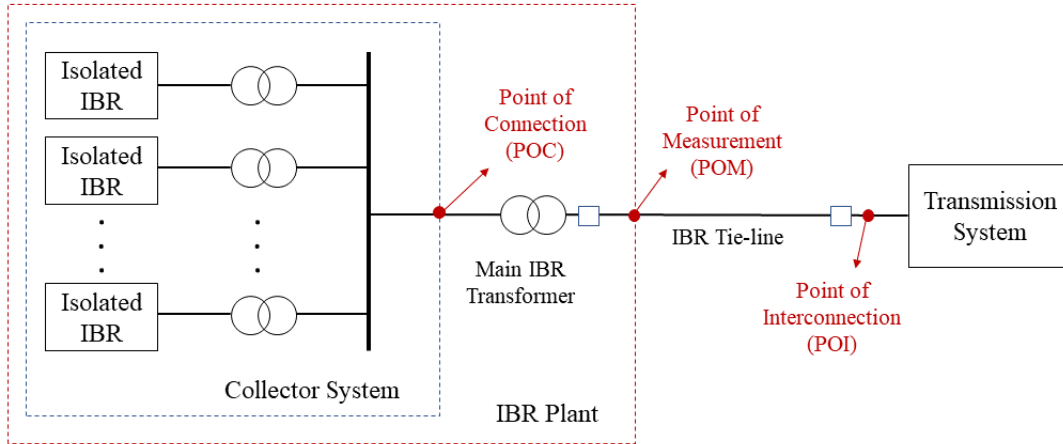

**Figure 2-1. Conceptual diagram describing the terms POC, POM, POI. Adapted from IEEE 2800 Std (IEEE, 2022).**

### 2.2.1 Inertia Estimation from Ambient Data

With the gradual replacement of synchronous generators with IBRs, the effective rotational inertia of the power system reduces. Reduced inertia implies high rate-of-change-of-frequency (ROCOF) and faster changes in system frequency with chances of excursions outside the reliable operating limits (Ashton, Saunders, Taylor, Carter, & Bradley, 2015). The inertia monitoring application is an online situational awareness tool that uses PMU data to estimate the effective area inertia (of a regional system) in quasi-real-time. The application may be designed to operate on ambient data, transient ringdown data, or both. Under ambient conditions, as a part of dynamic security assessment, this application periodically updates the operator with available system inertia – information that can be used in dynamic contingency planning and in control designs like scheduling of virtual inertia from the IBRs. This offers the transmission operator the ability to plan on fast frequency reserves.

In this project, an inertia monitoring application that would utilize continuous streaming of synchrophasor measurements was conceived. The application would divide a large, interconnected power system into multiple areas (or regional systems) and compute the effective inertia for each area. The application would require an estimation algorithm that fits a transfer function between the ambient perturbations in the system frequency measurements and the changes in the total load in that area. Assuming a quasi-state ambient operation, the change in load in an area is obtained by summing the ambient perturbations in generator and IBR power outputs, and the tie line flows into the area (Tuttelberg, Kilter, Wilson, & Uhlen, 2018). The inertia constant is calculated from the parameters of the estimated transfer function. Depending on the length of the estimation time-window, inertia estimation under ambient conditions may be coupled with the estimation of the electromechanical modal parameters.

BPA’s existing synchrophasor measurement infrastructure would be well-suited to support an inertia monitoring application. The application would require PMU measurements from all major generator and IBR buses and tie-line buses in an area. The accuracy of the inertia monitoring depends on the extent to which the inertial response is captured in the ambient dynamics. To that end, a modulator for perturbing the system variables could also be considered to excite the frequency dynamics.

**Table 2-3. Comparison of BPA’s measurement capabilities with the requirements of the inertia estimation application.**

	<b>Application Requirements</b>	<b>BPA’s Capabilities</b>	<b>Compatibility</b>
<b>Measurement Type</b>	PMU	PMU	✓
<b>Measurement Location</b>	Tie lines, SGs, and IBRs	Multiple locations in the TS	✓
<b>Reporting Rate</b>	at least 30 Hz	60 Hz	✓
<b>Synchronization</b>	Yes	Yes	✓
<b>Continuous Reporting</b>	Yes	Yes	✓
<b>Application Hosting (Centralized/Distributed)</b>	Centralized	Centralized	✓
<b>Online/Offline</b>	Online	Online	✓

### 2.2.2 Subsynchronous Oscillation (SSO) Source Localization

This application would use high-resolution measurements to detect, characterize, and localize occurrences of subsynchronous oscillatory phenomena in a power system. These oscillations may arise due to electrical interactions between series capacitors and IBR controls in type-3 and -4 wind generators or from the interactions solely within an IBR – between its outer control loops and a phase-locked loop (PLL) of low-frequency bandwidth or between its inner control loop and a PLL of higher-frequency bandwidth (Hatziaargyriou, et al., 2021) (Cheng, et al., 2023). On detection of an SSO, a necessary first step in its mitigation is locating the source. Thereafter, once the critical wind generators are identified, tripping or other control commands may be issued to stop the oscillation.

In the recent past, SSOs have been observed in the BPA system, especially under high wind conditions (Cheng, et al., 2023). With increasing penetration of wind systems, the occurrences of these oscillations will only increase in the coming years, motivating the need for an automated application for SSO detection and source localization.

The application would use time-stamped continuous or triggered POW measurements from DFRs at the IBR POI. The measurements would be time-synchronized and sent to a control center through communication links. At the control center, the current and the voltage waveform data from each DFR location would be processed to estimate the oscillation frequency and amplitude, along with the effective Thevenin impedance looking into the IBR terminals (Xu, Huang, Xie, & Li, 2022). In this analysis, a negative resistance implies the corresponding wind plant contributes positively towards sustaining the SSO.

The application could be designed for continuous reporting if the continuous streaming of POW data to the control center is available. This would require a major update on the communication system with regards to enhancing speed (in terms of samples-per-second) and bandwidth while minimizing the latency. Alternatively, the application could be designed to be activated on event triggers. Under such a scheme, the POW data from DFRs may be analyzed locally to detect for onset of SSOs without the need to stream data continuously to a central facility. Once an SSO is detected, the DFRs from multiple locations are triggered to record the measurements, timestamp them, and report it to the control center. The SSO localization application, hosted at the control center, then processes the time-aligned recorded data in quasi-real-time to identify the oscillation sources.

**Table 2-4. Comparison of BPA’s measurement capabilities with the requirements of the subsynchronous oscillation source localization application.**

	<b>Application Requirements</b>	<b>BPA’s Capabilities</b>	<b>Compatibility</b>
<b>Measurement Type</b>	POW	POW (DFR)	✓
<b>Measurement Location</b>	POI	POI	✓
<b>Reporting Rate</b>	Higher than 120 Hz	960 Hz	✓
<b>Synchronization</b>	Yes	No	
<b>Streaming</b>	Continuous (preferred), Trigger-based polling is fine if the application is also trigger-based	Polled	✓
<b>Application Hosting (Centralized/Distributed)</b>	Centralized	-	
<b>Online/Offline</b>	Online	Online	✓

### 2.2.3 Disturbance Monitoring

The recent events such as the Blue Cut Fire and the Canyon 2 Fire have identified limitations associated with the existing disturbance monitoring system at the IBR plants (NASPI, 2022) (NERC, 2020). The synchrophasor data, reporting at 60 frames-per-second, is often insufficient to adequately determine the inception, the cause, and the effects of different power system events like erroneous inverter tripping, momentary cessation, etc. These highlight the need for improved high-speed measurement systems for disturbance monitoring.

Typically, IBR related disturbances can be divided into the following types:

1. Voltage disturbances: transient overvoltage and undervoltage events, postfault voltage overshoot, sub-cycle transient overvoltage, successive voltage dips, etc.
2. Frequency disturbances: spurious frequency measurements caused by distortion and transients, underfrequency and overfrequency events, etc.
3. Current disturbances: instantaneous overcurrent, post-fault current injection, reverse current, negative and zero sequence current injection, etc.
4. Power quality disturbances: harmonic current/voltage distortions, rapid voltage changes and flickers.
5. Other disturbances: erroneous inverter tripping, momentary cessation as a form of ride-through, tripping based on instantaneous overvoltage, plant-level controller ramp rates interacting with the recovery, PLL synchronization issues, interconnection faults, unintentional islanding, reverse phase sequence, breaker failure, transformer failure (NERC, 2018).

In this application, artificial intelligence and machine learning (AI/ML) techniques would be applied to POW datasets to detect event signatures and their precursors. Labeled field-measured datasets would significantly aid in the offline training process and in the creation of event library. Online window-based

unsupervised statistical analysis could be used in detection of new events for which prior labels are not available.

The following salient points should be considered for this application:

1. Measurements from a large region that are time-synchronized can be used for detection of system-wide events. Unsynchronized measurements can only be used for local event detection. For every specific event, it is necessary to identify the relevant and the minimum set of measurements needed to detect it.
2. It is challenging to design a single application to detect all the types of disturbance events accurately. There does not exist any specific method which works on multimodal datasets to identify and categorize all the events with sufficient confidence. The detection methods are further challenged by measurement and model uncertainties.
3. The Blue Cut Fire and Canyon 2 Fire disturbances demonstrated that the measurements collected at POI are not sufficient to detect transient overvoltage that caused tripping of the IBRs. Inverter level recordings of grid voltage, inverter current, and calculated frequency at the terminal of POC provided the evidence for tripping. Availability of these measurements can enhance the detection performance.

For online implementation of the application at a control center, it is necessary to have a continuous streaming of time-synchronized POW measurements from IBR substations to the control center. However, streaming may not be needed for the detection of local events.

**Table 2-5. Comparison of BPA’s measurement capabilities with the requirements of the disturbance monitoring application.**

	<b>Application Requirements</b>	<b>BPA’s Capabilities</b>	<b>Compatibility</b>
<b>Measurement Type</b>	PMU, POW (DFR)	PMU, POW (DFR)	✓
<b>Measurement Location</b>	POI added value if POC-data available	POI	✓
<b>Reporting Rate</b>	Hundreds of Hz	60 Hz (PMU) 960 Hz (DFR)	✓
<b>Synchronization</b>	Yes	Yes (PMU) No (DFR)	✓
<b>Continuous Reporting</b>	Preferred	Yes (PMU) No (DFR)	✓
<b>Application Hosting (Centralized/Distributed)</b>	Centralized, may be distributed for local events	-	
<b>Online/Offline</b>	Online	Online (PMU) Offline (DFR)	✓

## 2.2.4 Data-Driven Modeling for Stability and Control

Data-driven models can be used to predict the behavior of IBR when connected to the grid during normal operating conditions, contingencies, and varying environmental factors. These models are of two types: black box models and gray box models. Both impedance/admittance spectrum models can be estimated in those structures. Impedance/admittance spectrum models (Fan L. , et al., 2022) (Fan & Miao, 2020) until now have been estimated using frequency scanning techniques and frequency domain analysis. The model is derived using a class of system identification algorithms that first inject voltage perturbations in the form of single-frequency sinusoids. The voltage and current measurements at the terminals of IBRs or plant and network are then recorded. Utilizing those measurement data, a multi-port admittance-based transfer function matrix is formulated. This multi-input multi-output system with transfer functions is then utilized to do stability analysis or control designs for IBRs.

Data-driven models are appealing for the following reasons:

- Data-driven models can be used for stability analysis, sub-synchronous resonance (SSR) mitigation, and control system design for IBR-based systems.
- Measurements can lead to more accurate models for predicting system behavior under the varying operating condition that can be used in detailed planning studies with IBRs for faster simulation.
- As per a recent NERC disturbance monitoring report (NERC, 2020), parameterization of the models used in root mean square (RMS) positive sequence simulation platforms for interconnection-wide studies do not completely represent the large disturbance behavior of IBRs, such as momentary cessation and ride-through scenarios. This causes errors in the planning studies performed by transmission planners, planning coordinators, and reliability coordinators. With high-speed measurements, it is expected that more detailed models can be calibrated to perform studies to identify any potential instability conditions.
- Streaming measurements can be used to update admittance spectrum models at different nodes in the power system in the online environment to monitor system stability in real-time.

Implementing this application requires POW measurements from POM under different grid dynamic events to accurately represent the IBR plant. Historical plant level measurement recordings and wide area phasor measurements are sufficient for black box model estimation. Information on the availability of the number of IBRs and their capacities, plant level control settings, limits, and ramp rates would be helpful in accurately differentiating between the IBR plant operating regions in gray box-based IBR model identification.

**Table 2-6. Comparison of BPA’s measurement capabilities with the requirements of the data-driven modeling for stability and control application.**

	<b>Application Requirements</b>	<b>BPA’s Capabilities</b>	<b>Compatibility</b>
<b>Measurement Type</b>	PMU, POW (DFR)	PMU, POW (DFR)	✓
<b>Measurement Location</b>	POM and/or POC	POI, POM	✓
<b>Reporting Rate</b>	60Hz PMU and >2kHz (DFR)	60 Hz (PMU) 960 Hz (DFR)	

<b>Synchronization</b>	Yes	Yes (PMU) No (DFR)	
<b>Continuous Streaming</b>	Preferred	Yes (PMU) No (DFR)	✓
<b>Application Hosting (Centralized/Distributed)</b>	Centralized/Distributed	-	
<b>Online/Offline</b>	Offline	Online (PMU) Offline (DFR)	✓

## 2.2.5 Monitoring Support for Ride-Through Control Capability

As defined by IEEE Standard 1547<sup>TM</sup>-2018, ride-through is the ability to withstand voltage or frequency disturbances inside defined limits and to continue operating as specified (Photovoltaics, 2018). Ride-through controls prevent inverters from tripping under an overcurrent, overvoltage, over-power, over-energy, etc. (Hart, 2022). These controls are applied for both voltage and frequency and are necessary for protection systems to reliably operate. Power plant controllers are responsible for grid integration functions such as ride-through under low-voltage, high-voltage, and under-frequency ride-through. The IBR plant response is dominated by that of individual IBR units under this type of control and requires coordination between plant-level and individual unit-level controls. POM and POC measurements of voltage and frequency can be used for input into the control mechanism for maintaining stability during disturbance conditions (Hart, 2022).

Existing ride-through settings at individual IBRs are different which causes a misoperation from IBR plant output. The main problem here is ride through settings based on IBR terminal measurements may not be an accurate representation of grid conditions and what is expected from the IBR plant by the transmission operators. NERC reports have highlighted the need to adjust these settings, though there does not exist any single prescribed way to modify them. The process of modification is location dependent. In this case, a wide area measurements-based support to manage each IBRs can play a key role, which provides generator operators with actionable information from the transmission operator to integrate these types of controls.

The conceived application would support plant-level ride-through controls by (1) carefully monitoring plant-level injection patterns over time and (2) identifying the periods at which a ride-through mode of operation from IBRs is desired by transmission operators. This would improve transmission reliability and contribute positively to system transient stability. Synchronized wide-area measurements from the transmission grid as well as from plant-level voltage, frequency, current injections, and power injections at POIs would be analyzed to determine the ride-through regions of operation and any discrepancies in plant-level aggregated injections. Based on the historical data analysis, the proposed algorithm would derive actionable quantities from the extracted measurements to help inform IBR plant owners/generator operators. Once trained, the algorithm could be deployed online to derive recommendation metrics for plant owners on when it is essential to continue to inject in a ride-through mode of operation from inverters. The online algorithm can then be used by transmission operators to inform on ride-through control methods necessary to avoid problematic IBR tripping negatively contributing to system damping and causing unstable scenarios.

**Table 2-7. Comparison of BPA’s measurement capabilities with the requirements of the monitoring support for ride-through control capability application.**

	<b>Application Requirements</b>	<b>BPA’s Capabilities</b>	<b>Compatibility</b>
<b>Measurement Type</b>	PMU, POW (DFR)	PMU, POW (DFR)	✓
<b>Measurement Location</b>	POM and/or POC	POI, POM	✓
<b>Reporting Rate</b>	60Hz PMU and >3-20 kHz (DFR)	60 Hz (PMU) 960 Hz (DFR)	
<b>Synchronization</b>	Yes	Yes (PMU) No (DFR)	
<b>Continuous Streaming</b>	Preferred	Yes (PMU) No (DFR)	
<b>Application Hosting (Centralized/Distributed)</b>	Centralized/Distributed	-	
<b>Online/Offline</b>	Online	Online (PMU) Offline (DFR)	✓

### 2.2.6 Anti-Islanding Protection

Anti-islanding protection in an IBR refers to its ability to disconnect from the transmission system when the grid is undergoing major power loss. This prevents the formation and sustained existence of unintended islands with local load-generation balance (Kroposki, 2016) (da Cunha Lima, et al., 2021). Common methods for anti-islanding protection include the design of reverse/minimum import/export relays, passive/active islanding, and communication-based methods.

Deployment of anti-islanding protection capability for IBR plants is important for the following reasons:

- As per IEEE 1547 standard test requirements, each inverter is tested for anti-islanding studies. However, it does not test groups of inverters of similar or different manufacturers or at the IBR plant for islanding detection (Anti-Islanding Protection with Grid-Tied PV Inverters, 2023).
- There does not exist a single active islanding function in an IBR plant which involves IBRs from different manufacturers (Anti-Islanding Protection with Grid-Tied PV Inverters, 2023).
- Duration of continuous operation in case of an unintentional island for different generating systems and loads might be different (Anti-Islanding Protection with Grid-Tied PV Inverters, 2023).
- IEC 62116 has presented a requirement to have sensitive anti-islanding techniques. However, false islanding detection events can result in protection misoperation, undesirable IBR disconnections (da Cunha Lima, et al., 2021) (Vandenberghe, 2004), and dangerous situations for people. This can in turn lead to cascading events under different circumstances affecting bulk system operation.
- Existing anti-islanding algorithms of IBRs are not immune to grid disturbances or event-driven voltage and frequency oscillations and there does not exist any solution to differentiate between the two (da Cunha Lima, et al., 2021).

- Existing anti-islanding algorithms are sensitive to changes in grid impedance for detecting islands (AESO, 2022).

For detecting an unintentional island with a high degree of confidence and differentiating those from a ride-through scenario, wide area grid level phasor measurements and IBR plant POI POW measurements need to be combined for input to the detection technique. This requires continuous monitoring data to identify changes in grid impedance and corresponding islanding patterns to train the AI/ML model. After testing, these trained models can be deployed online to inform plant owners and utilities of the precursors to the islanding situation and help in applying anti-islanding control and protection methods.

**Table 2-8. Comparison of BPA’s measurement capabilities with the requirements of anti-islanding protection application.**

	<b>Application Requirements</b>	<b>BPA’s Capabilities</b>	<b>Compatibility</b>
<b>Measurement Type</b>	PMU, POW (DFR)	PMU, POW (DFR)	✓
<b>Measurement Location</b>	POM	POI, POM	✓
<b>Reporting Rate</b>	60-120 Hz PMU and >3-20 kHz (DFR)	60 Hz (PMU) 960 Hz (DFR)	
<b>Synchronization</b>	Yes	Yes (PMU) No (DFR)	
<b>Continuous Streaming</b>	Preferred	Yes (PMU) No (DFR)	
<b>Application Hosting (Centralized/Distributed)</b>	Centralized/Distributed	-	
<b>Online/Offline</b>	Online	Online (PMU) Offline (DFR)	✓

### 2.2.7 Weak Grid Planning

The “strength” of a system refers to its ability to transfer power in steady state while maintaining adequate margins of voltage and frequency stability (Jayasinghe, 2021). Several quantities such as Short Circuit Ratio (SCR), X/R ratio, and ROCOF (Photovoltaics, 2018), and their modified versions, are typically used to quantify the strength of a connection point for an IBR-connected grid. When IBR-injected currents affect the POI voltage magnitude significantly, the system is considered as weak. Weak grids affect the inertial response or fast voltage angle fluctuations. Weak grid situations are also responsible for problems in voltage recovery (Huang, 2012) during fault or N-1 conditions. Weak grid studies focus on the performance challenges associated with connecting IBRs to weak grids. These studies require extensive transient simulations of the system for identifying modeling, control, and protection issues while accurately predicting system behavior and designing mitigation measures. These types of studies are heavily dependent on models, which are in turn calibrated using both PMU data and POW data. Thus, measurements are necessary not just for the identification and classification of weak grids but also for designing appropriate control and protection measures and thus require both PMU and POW measurements.

The major challenge under a weak grid condition is large signal stability which involves recovery during and after fault conditions. Controls need to be adjusted to reduce/slow down active power recovery and

provide high voltage magnitude control. These operations require continuous synchronized monitoring of voltages and active power, reactive power, and currents at the plant. These measurements are then used as input to the control algorithms to adjust injections from IBRs into the grid or apply power flow control to maintain system voltage.

In this application, wide area phasor measurements and POW measurements would be analyzed to develop different types of system and asset level metrics (Photovoltaics, 2018) to understand the system strength and reliability contribution of each IBR plant. The metrics would be developed from offline dynamic simulation studies of N-K scenarios and would be tested and validated on field measurements to predict system strength online. The estimation performance on how much each IBR site is supporting would be evaluated in different grid dynamic disturbances and would help in identifying the plant controls which need to slow down the active power and voltage recovery for supporting weak grid conditions.

**Table 2-9. Comparison of BPA’s measurement capabilities with the requirements of weak grid planning application.**

	<b>Application Requirements</b>	<b>BPA’s Capabilities</b>	<b>Compatibility</b>
<b>Measurement Type</b>	PMU, POW (DFR)	PMU, POW (DFR)	✓
<b>Measurement Location</b>	POM	POI, POM	✓
<b>Reporting Rate</b>	Hundreds of Hz	60 Hz (PMU) 960 Hz (DFR)	
<b>Synchronization</b>	Yes	Yes (PMU) No (DFR)	
<b>Continuous Streaming</b>	No	Yes (PMU) No (DFR)	
<b>Application Hosting (Centralized/Distributed)</b>	Centralized	-	
<b>Online/Offline</b>	Offline	Online (PMU) Offline (DFR)	✓

## 2.3 PNNL’s Field Demonstration Plan

After evaluating the applications discussed in Section 2.2, the PNNL project team met with staff members from BPA to present the ideas and receive feedback. Based on this discussion, the disturbance monitoring (Section 2.2.3) and data-driven modeling (Section 2.2.4) applications have been selected for further development in the project’s second year. Because these applications require POW measurements that are not yet available in the field, they will be demonstrated offline using simulated measurements.

The meeting with BPA also led to the identification of an application suitable for a live field demonstration. The application, which was suggested by a BPA engineer, was for a *Generator Scorecard* tool to automatically evaluate the performance of power plants within BPA’s territory. The Generator Scorecard application will address BPA’s need to automatically monitor the performance of the many new IBR power plants that are being brought online. This will be accomplished by first monitoring voltage, active power, and reactive power measurements streamed from substations serving power plants, including IBRs. Leveraging prior research, events due to generator tripping, capacitor switching, line

switching, and others will be detected. Automated methods will then be used to evaluate the frequency- and voltage-regulation performance using the collected measurements. The application will also identify improper power plant tripping based on NERC's PRC-024. The application will develop reports (generator scorecards) for review by BPA. A conceptual illustration of a report is presented in Figure 2-2.

Following initial development, the Generator Scorecard application will be tested with field-measured data from BPA. The data was provided to PNNL under prior arrangements, and BPA has agreed to allow PNNL to use the data to support the PROGRESS MATRIX project. The data used for testing will be drawn from 4.7 TB of data from 26 PMUs collected over a two-year period. Measurements from three wind farms will be the primary focus of the analysis.

After initial development and offline testing are complete, the application will be implemented as an extension of the Archive Walker tool to facilitate the field demonstration. Archive Walker is a tool for the identification of periods of interest in PMU data that was developed by PNNL and initially conceived by BPA (Follum, et al., 2018). It was designed to be readily extensible, so it is ideal for use in this demonstration. As depicted in Figure 2-3, Archive Walker's user interface enables fast review of detected disturbances, a feature that will be important for reviewing the application's results. Once the Generator Scorecard capability is integrated, Archive Walker will be deployed for testing and field demonstration at BPA's synchrophasor laboratory in Vancouver, Washington. The tool will monitor PMU data in near real time from multiple substations near power plants. PNNL will work with BPA to review results and evaluate the tool's performance.

**Generator 1: Pass**

Ridethrough: 89 of 90 disturbances

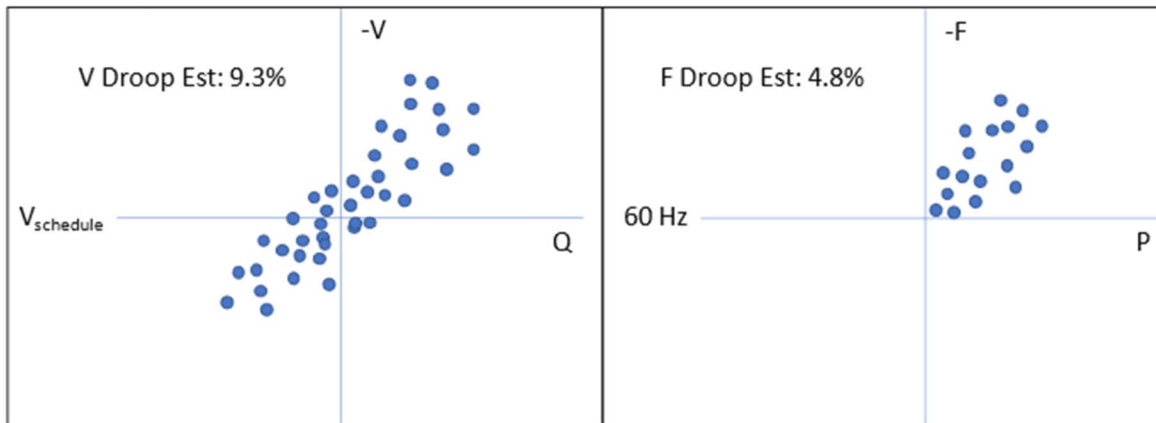

**Generator 2: Fail**

Ridethrough: 75 of 90 disturbances

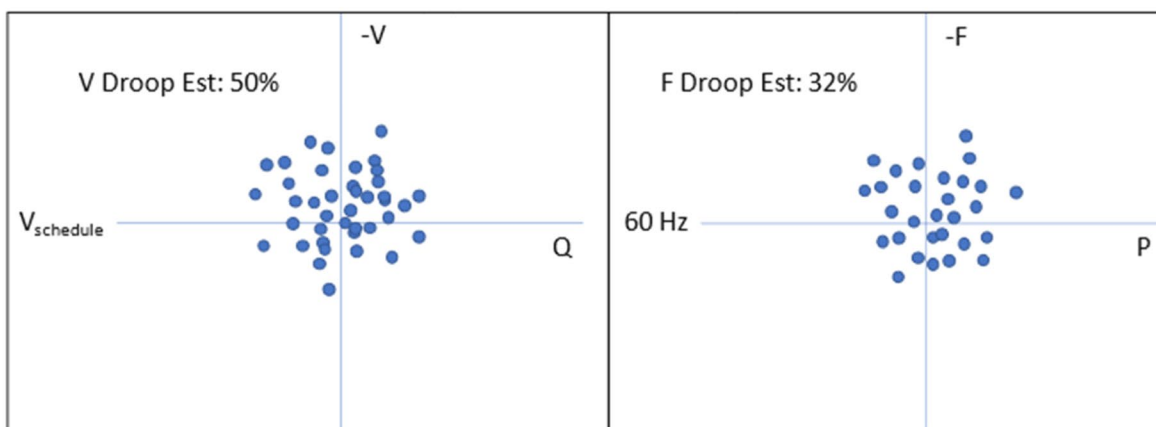

**Figure 2-2. Conceptual illustration of the Generator Scorecard report for two generators. These diagrams are based on images shared by BPA.**

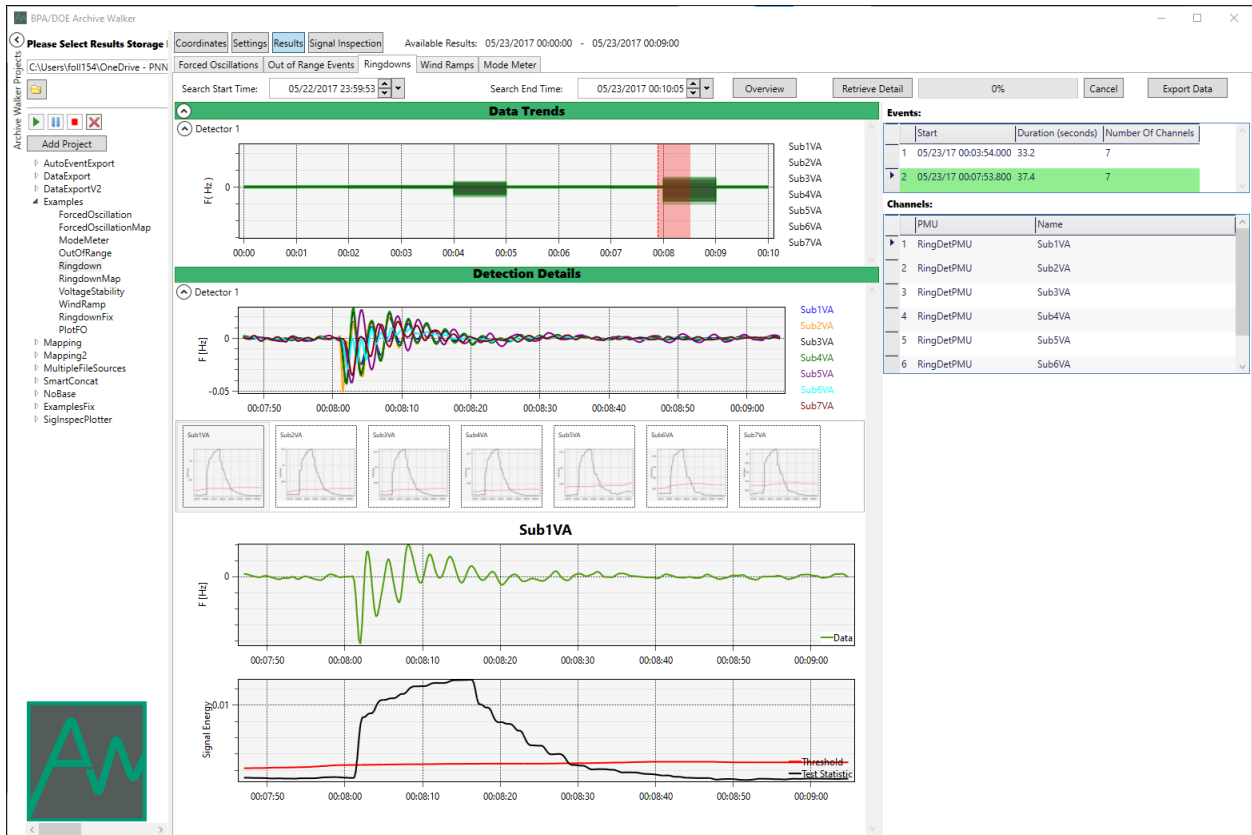

Figure 2-3. Screen capture of the Archive Walker user interface showing the detection of an oscillation in PMU measurements.

## 3.0 KIUC Gap Analysis

Kauai Island Utility Cooperative (KIUC) is a not-for-profit electric cooperative operating on the Island of Kauai, Hawaii. KIUC's generation fleet includes 260MW of installed capacity, with an average of roughly 50MW in operation. The KIUC generates nearly 70 percent of its power from renewable sources. KIUC owns approximately 1500 miles of transmission and distribution circuits and includes 4,300 rooftop solar systems in service (Kauai Island Utility Cooperative, 2023).

### 3.1 KIUC's Existing Measurement Capabilities

As inverter-based resources (IBRs) continue to increase in distribution systems it is important to improve monitoring technologies, ensuring the safe, efficient, and reliable operation of IBRs and their integration with the bulk power grid. NERC has published multiple reports and emphasized that monitoring is crucial to understand the performance of IBRs, particularly for post-event analysis after system faults. Grid measurement is a broad topic—there are many different types of grid measurements. The goal of this evaluation is to understand the monitoring capability of IBRs in industry by summarizing for a particular utility--KIUC. The focus of the summary is the high-speed grid measurements that are most important for dynamic modelling and analysis of IBRs during system events such as faults.

#### 3.1.1 Site-Specific Analysis

In this survey, the measurement capabilities of a single substation were investigated. The site chosen is a solar PV plus Battery Energy Storage System (BESS) and pumped storage hydro project. The solar photovoltaic (PV) generating capacity is 35 MW, and BESS also has 35 MW capacity.

At the point of interconnection (POI) and point of common coupling (PCC), IEEE Standard 2030.8 was used as requirements for measurement data intervals. Two types of instruments are mainly used for high-speed grid measurement data collection: protective relays and digital fault recorders.

##### 3.1.1.1 Protective Relays

The protective relays can measure and record basic grid attributes. For example, they can measure sequence of event (SOE) records, and time stamp all the protective element decisions. They can also record event oscillography data in COMTRADE data format. The oscillography data is usually high sampling rate point-on-wave data recorded by relay during system disturbances. In addition, the protective relays can measure and provide synchrophasor data in the format of IEEE C37.118. The synchrophasor data is usually at a lower rate (e.g., 30 Hz, 60Hz) compared to high sampling rate oscillography data. The measurements of synchrophasor data usually include power, RMS, phase angle, grid frequency, etc.

##### 3.1.1.2 Digital Fault Recorders

Digital Fault Recorders (DFRs) can be used to collect high-speed power grid measurement data. For example, the TESLA 4000 DFR has the capability to both record and stream synchrophasor data using its integrated PMU. The instrument can record high sampling rate POW data with a configurable sampling rate and record length. The POW data total length can be configured from 0.2 seconds to 15 seconds, and pre-fault length can be configured from 0 seconds to 8 seconds. The number of samples per cycle can be

configured from 32 to 384, which is equivalently from 1.92 Hz to 23.04 kHz. The device can be accessed remotely via communication link.

### **3.1.1.3 Time Synchronization**

Grid measurements should be time stamped with high accuracy. The GPS satellite receiver can be used to provide time synchronization signals for the entire facility including: all protective relays, all network equipment, all controllers, all inverters, and all other electronics.

## **3.1.2 General High-Speed Measurement Capabilities at KIUC**

In larger KIUC substations, DFRs are used to collect high-speed measurements. The DFRs can work as multi-functional instruments based on configurations.

### **3.1.2.1 DFR High-Speed Mode**

In high-speed transient mode, the DFR can measure and collect high-resolution POW data, at a level of several kHz (e.g., 7680 Hz). Note that the high-speed data collection under this mode is not continuous, instead it is trigger-based data acquisition. The duration of data that can be recorded is at the level of several seconds. The data is saved in local memory and could be overwritten when the memory is full and new events are recorded.

Note that the high-speed POW data is the most critical data for in-depth analysis of IBRs during system transient events or faults. It should also be noted that high-speed POW data is usually collected based on event triggers and not collected contiguously, so there is no guarantee that POW data could be captured for a given system event. The POW data for an event may not be captured at all due to the limitations of triggering functions, or the data may be overwritten when the memory is full in the local device.

### **3.1.2.2 DFR PMU Mode**

The DFRs used at KIUC can also be configured to provide PMU functionality. In this mode, the measurements are computed and streamed continuously through the network, and all the measurements are time stamped. The measurements are synchrophasor measurements, which typically include power, RMS, phase angle, and frequency. The measurement rate is typically 60 samples per second.

### **3.1.2.3 Universal Grid Analyzers**

In addition to DFRs, another type of high-speed measurement instrument—Universal Grid Analyzers (UGAs)—are also used to monitor the KIUC power grid. The UGA is a multi-functional and easy-to-deploy measurement instrument developed by the University of Tennessee and ORNL (Lingwei Zhan, 2015). The UGA can provide synchrophasor measurements including RMS, phase angle, frequency, and ROCOF. All measurements are time synchronized by GPS. The measurement rate of the UGA can be configured from 10 Hz to 120 Hz. Beyond the synchrophasor function, the UGA can also perform power quality analysis, such as harmonics, sag/swell, and unique noise analysis.

More importantly, motivated by the emerging need and high value of high-speed POW data, the UGA development team is developing a continuous POW measurement function in the UGA. Instead of the trigger-based POW measurement function used by DFRs that only record POW data during system

events, the UGA could record the POW data continuously, and stream the continuous POW data over a network to a data server.

## 3.2 Application Evaluation

Both the monitoring and understanding of grid disturbances contributed to by IBRs require necessary measurement capabilities. These capabilities will be dependent on a number of factors, described in the following subsections. Several key application areas are also described in detail, including:

- Grid frequency characterization and extreme frequency event detection,
- IBR-related high-frequency oscillation detection and modeling
- Study of IBR-related grid signatures captured by POW measurement devices

### 3.2.1 Grid Frequency Characterization and Extreme Frequency Event Detection

Detecting extreme frequency and characterizing the grid frequency is critical to understand the stability and robustness of the power grid. Due to the ever-increasingly high penetration of renewable energy resources, the grid frequency will vary drastically as more dynamics are introduced into the system, largely because of a lack of sufficient large rotational inertia. Inertia is provided by traditional large turbines and generators due to stored rotational energy, allowing for the system to remain online long enough for the problem to be addressed. However, typical sources of renewable energy (wind, solar, etc.) do not produce the level of stored energy needed to “keep the system afloat”, opening the door for increased instability problems not seen in the past.

The characterization of grid frequency includes analysis of two distinct aspects: ambient frequency and disturbance-related frequency. Ambient grid frequency under normal grid operations without major grid events can be characterized in terms of statistics such as frequency distribution, varying over different variables such as hours of the day or seasons in the year. Disturbance-related frequency may be characterized using parameters such as ROCOF, frequency nadir (minimum), etc. The ROCOF gives a measure of how severely the operating frequency of the system is changing with respect to time.

To study the aforementioned frequency characteristics in a highly renewable power grid, the measurements need to be taken from an area with a high concentration of renewables. To understand the frequency resulting from dynamic behavior, a measurement rate of at least 10 Hz is recommended. Additionally, a measurement accuracy of 5 mHz (milli-Hertz) and timing accuracy of 1 microsecond, following the IEEE/IEC PMU Standard 60255-118-1-2018 which is met by PMUs utilized by industry today. However, it should be noted that these requirements are subject to change, as frequency of the grid with distributed energy resources (DERs) at the distribution level could be subject to more dynamics than those at the transmission level. Measurement latency is not a factor here as this application is focused on offline analysis. Table 3-1 summarizes these requirements.

High-speed synchronized frequency measurements can be provided by PMUs or other measurement instruments, such as relays or DFRs, that have synchrophasor measurement capabilities built in. Wide-spread deployment of PMUs and/or DFRs at the distribution level is generally not economically feasible. Instead, distribution-level phasor measurement devices, such as the Universal Grid Analyzer (UGA) (Lingwei Zhan, 2015), may be used as an alternative.

Multiple distribution-level phasor measurement devices, such as the UGA, have been deployed in substations at KIUC near sites of installed renewables. These devices possess the capability to stream frequency readings continuously. At the time of the writing of this report, there is no significant observed challenge limiting the deployment of such devices for this application. The primary challenge is ensuring the devices operate continuously over the course of an entire year, covering all four seasons.

**Table 3-1. Requirements for grid frequency characterization and measuring extreme frequency events.**

<b>Requirements</b>	
<b>Measurement Location</b>	Any area with a high concentration of renewables
<b>Measurement Parameter</b>	Frequency
<b>Measurement Rate</b>	$\geq 10$ Hz
<b>Measurement Accuracy</b>	$< 5$ mHz
<b>Timing Accuracy</b>	1 $\mu$ s
<b>Measurement Latency</b>	No

### 3.2.2 IBR-Related High-Frequency Oscillation Detection and Modeling

Oscillations are an inherent phenomenon in power systems that can threaten grid reliability if not managed or mitigated appropriately. Traditional low frequency power system oscillations in the large scale grid have been well studied in recent years with the help of the widespread deployment of PMUs and associated software tools. Frequencies of these oscillations are usually below 1 Hz; thus, they can be easily captured by PMUs. However, the oscillation frequencies in areas with high concentration of renewables may be much higher, sometimes reaching as high as 20-40 Hz (e.g., subsynchronous oscillations).

These higher oscillation frequencies pose significant challenges to measurement systems. First, per the Nyquist-Shannon sampling theorem, the measurement sampling rate must be at least twice the highest oscillation frequency to fully capture the oscillation. In practice, three to five times are recommended for accurate estimation. In other words, for an oscillation of 40 Hz, it is recommended that measurement rate is at least 120 Hz, which is rarely met by existing phasor measurement systems. Second, it should be noted that typically the measurement data itself are filtered representations of the phenomena being captured, and as such may not have the oscillations preserved in the measurements. As a result, the oscillations would not be captured at all no matter the sampling rate.

**Table 3-2. Requirements for measurement of high-frequency oscillations**

	<b>Requirement</b>	
<b>Measurement Parameter</b>	Voltage, Phase Angle, Power, Frequency	POW
<b>Measurement Location</b>	Any area with a high concentration of renewables	Any area with a high concentration of renewables
<b>Measurement Rate</b>	$2f_{osc}$	960 Hz
<b>Measurement Bandwidth</b>	$f_{osc}$	$f_{osc}$
<b>Measurement Accuracy</b>	IEEE/IEC 60255-118-1-2018	1%
<b>Timing Accuracy</b>	1 $\mu$ s	1 $\mu$ s
<b>Measurement Latency</b>	No	No

Grid oscillations may be observed in many measurement parameters, including voltage, phase angle, power, and frequency. Choosing the quantity that is most suitable for oscillation detection and modelling is dependent on the type of oscillation being studied. The measurement rate of these quantities is a key requirement, and the requirement depends on the maximum frequency of the oscillation to be detected, denoted as  $f_{osc}$  in the table. Theoretically, the measurement frequency must be at least twice the frequency of the target oscillation. For example, a 10 Hz oscillation frequency needs at least a sampling rate of 20 Hz. In practice, the sampling rate should be 3 to 5 times of target frequency. However, it should be emphasized that satisfaction of the sampling rate requirement does not necessarily guarantee the oscillation can be detected from the measurements. The bandwidth of these measurements needs to be satisfied as well. Generally, analog or digital filters are applied for computing these measurement quantities, and these filters will have some bandwidth associated with them. For example, synchrophasor computations usually use the Discrete Fourier Transform (DFT), and DFT itself introduces a “low-pass filter” property on the measurements, resulting in filtering out high frequency components in the final measurement output.

Unfortunately, the bandwidth of these measurement quantities measured by PMUs are not usually provided, and users of the measurement data are not aware of it as a result. This information may be gleaned by either consulting the manufacturers or performing lab tests on the instrumentation. It should be noted, however, that IEEE/IEC 60255-118-1-2018 only has an oscillation frequency accuracy requirement of up to 5 Hz (magnitude, and phase angle), so it should not override the bandwidth and sampling rate requirements.

Aside from these measurement quantities, POW measurement data can serve as an alternative measurement data source. This is because POW measurement data provides access to the raw grid waveforms, facilitating great flexibility for developing suitable oscillation detection methods. In other words, POW measurement data allows the user to develop measurement (e.g., voltage RMS, phase angle) methods that have high bandwidth and are suitable for oscillation detection. A sampling rate of 960 Hz

(16 sample per cycle for 60 Hz power grid) and 1% magnitude error can be satisfied by most POW measurement devices, while also satisfying measurement requirements for oscillation detection.

### **3.2.2.1 Limitations of Deployment of Advanced Measurement Applications**

To capture and analyze oscillations, detection methods need to be developed. These types of algorithms are currently not widely deployed, thus continued research and development is needed for continued enhancement. Additionally, installation of relevant equipment needs to be completed at sites determined to be sources of oscillations. The measurement data required by the developed detection methods will determine what quantities need to be measured. The measurement data may include, but is not limited to voltage magnitude, phase angle, frequency, or POW measurements.

Note that this assumes that the detection algorithms are deployed in a remote server, outside of the measurement device. An alternative approach is to deploy the oscillation detection method inside the grid measurement instrument; however, this will increase the cost of production of these measurement devices, increase the computational burden required on the measurement device, and stress network bandwidth (because oscillation detection methods require measurements from multiple locations, the data must be streamed in near real-time).

As discussed previously, voltage, phase angle, power, and frequency may be obtained from PMUs. Reporting rates of PMUs typically range from 10 Hz to 60 Hz. However, the bandwidth capabilities of the PMUs are not usually provided. IEEE/IEC 60255-118-1-2018 suggests a maximum requirement of 5 Hz dynamic oscillations (magnitude and phase angle), therefore PMUs should be able to capture magnitude and phase angle oscillations that are lower than 5 Hz. However, it is uncertain that oscillations higher than 5 Hz frequency can be reflected in PMU measurements with existing hardware due to these bandwidth restrictions.

POW measurement data is usually captured by DFRs. The POW measurements by DFRs are usually trigger-based, thus POW measurement data are collected intermittently.

### **3.2.3 Study of Higher-Frequency Grid Signatures**

DERs typically use power converters (e.g., DC/DC, DC/AC) to convert electricity and interface with the bulk power grid. Power converters often operate at kHz level due to the switching operations used in the conversion process, so they have much faster dynamic response capabilities and control flexibility when compared to traditional generators. Therefore, interactions between the bulk power grid and connected DERs is much more complicated and has not been well studied. For example, in Blue Cut Fire event, the line-to-line fault caused over 700 MW of solar interruption. It was later found that the measurement algorithm used by solar inverters wrongly estimated the grid frequency, triggering the low frequency protection of solar inverters. Among the different types of measurement data, POW data could be of most significant value as it provides measurements at the lowest-level and highest fidelity whereas all other measurement types in this space are processed using said POW data. For example, to study the root cause of a phase-locked loop (PLL) measurement problem (as with the case of the Blue Cut Fire), only POW data will be enlightening because the PLL measurement algorithm uses POW data as its input for frequency estimation. In other words, a lot of high-speed information is lost when POW is processed into lower reporting rate measurement quantities, such as those produced by PMUs.

### 3.2.3.1 Challenges Associated with Measurement of POW Data

Although POW is of significant value to performance analysis of DERs and the study of highly renewable power grids, acquiring POW data is not trivial. POW measurements require very high sampling rates, therefore storage and transfer of the data is costly. Therefore, instruments such as DFRs and relays only collect POW data during triggered system events and thus only store a short period of POW data (usually less than one second for an event) in local storage. Using these devices to collect POW data in distribution networks is not practical for several reasons: 1) they are expensive; 2) they are multi-functional devices and mostly designed for transmission networks; 3) they collect POW data using triggers that are configurable, and the adaptability of these configuration settings to distribution networks is unknown; and 4) only a short period of POW data during system events can be obtained, therefore ambient (i.e. steady-state operating) POW data is not usually available.

**Table 3-3. General requirements for POW measurements of IBR-related disturbances**

<b>POW Measurement Requirements</b>	
<b>Measurement Location</b>	Any area with a high concentration of renewables
<b>Measurement Parameter</b>	Voltage and/or current waveforms
<b>Measurement Rate</b>	> 960 Hz
<b>Measurement Accuracy</b>	< 1%
<b>Timing Accuracy</b>	1 $\mu$ s
<b>Measurement Latency</b>	No
<b>Continuous Measurement</b>	Yes

### 3.3 ORNL’s Live Demonstration Plan

The first priority application ORNL will develop is grid frequency characterization and event detection. Frequency characterization under normal conditions can be highly variable in systems with high IBR content. The same is true during significant disturbances, making this an important metric of grid health. The fast system dynamics introduced by renewables will cause more dynamic distortions and interferences in grid frequency, making accurate and fast grid frequency measurement more challenging. This study will identify the challenges by analyzing the performances and limitations of industry widely used algorithms and provide recommendations to help estimate grid frequency more accurately and reliably. Data collected from the high renewable grid at KIUC will be used to develop and evaluate algorithms to address generation tripping, load shedding, faults, and other transients, within the context of frequency-based measurements. Synthetic models and testbeds will be used to supplement data as needed.

The second priority application will expand upon the first using POW measurements. The task would develop appropriate event triggering techniques needed for continuous measurements and investigate the event classification solutions for high IBR content systems. The interaction between IBRs and bulk power grid during system events could introduce dynamic or transient distortions to power grid waveforms.

Capturing the waveforms during the events is critical to understand the behaviors and operations of IBRs and its interactions with bulk power grid. First, we will develop event detection methods that can extract anomalous waveforms from continuous POW data. Due to the potential large volume of POW data, the detection method must be computationally efficient and fast for events detection. Second, we will perform data analytics on the POW data, and implement event type identification. Continuous POW measurement data is not currently available from KIUC, but ORNL can leverage POW data from other partners it already has access to. High IBR content synthetic models and testbeds will be used to generate testing and training data.

### **Testbed Setup and Demonstration**

This work will develop the applications and analytics tools and then validate them in laboratory using ORNL's Hardware Testbed (HTB), the high-fidelity sensor testing system, and sensor testbed of Distributed Energy Communications and Controls (DECC) Laboratory. Specifically, the HTB will be programmed to emulate the static and dynamic behaviors of IBRs as well as electric power grid (e.g., transmission and distribution system, IBRs, and microgrids, etc.) to provide a close-to-real-world platform for evaluating sensor measurement performances and response of IBRs under various power system events. This enables fast development and efficient pre-deployment validation of the new monitoring strategies and analytics tools.

Additionally, ORNL's high-fidelity and automation sensor test system will be used to evaluate sensor measurement performance and provide further feedback for measurement specifications to meet the modelling and analytics of IBRs. The test system can automatically produce various voltage and current waveforms as well as replay real system events, thus finish hundreds of tests in a couple of hours.

The DECC Laboratory at ORNL houses and manages indoor and outdoor sensor testbeds, which allows for characterization of field-level measurements using actual equipment. Various sensing technologies, including instrument transformers, will be characterized against various IBR-related events.

ORNL's live demonstration will be performed with the Hardware Testbed of its DECC. Some integration will also take place with the Anomaly Detection Testbed (also in DECC), and Advanced Protection and Controls Lab (GRID-C), where hardware in the loop (HIL) simulations are planned for testing. The ultimate demonstration will leverage each setup to demonstrate the application(s) most fully. ORNL plans to demonstrate the grid frequency characterization and event detection application using the testbed setup. The POW measurement application will be demonstrated offline. ORNL's offline demonstrations will utilize synthetic models/data and (if applicable) collected field data. The algorithms will be demonstrated and documented for their functionality and performance.

## 4.0 WAPA Gap Analysis

WAPA's customer service territory is divided into five regions, as shown in Figure 4-1. The Upper Great Plains Region (UGP) spans Montana, North and South Dakota, eastern Nebraska, western Minnesota, and Iowa regions. The Rocky Mountain Region (RM) spans Wyoming, western Nebraska, western and northern Kansas, and Colorado. The Desert Southwest Region (DSW) constitutes southern Nevada, northeast Arizona, and southern California. The Sierra Nevada Region (SN) covers northern California and northern Nevada. The Colorado River Storage Project Region (CRSP) covers northeastern Nevada, Utah, New Mexico, west Texas, and northeastern Arizona (WAPA, 2023).

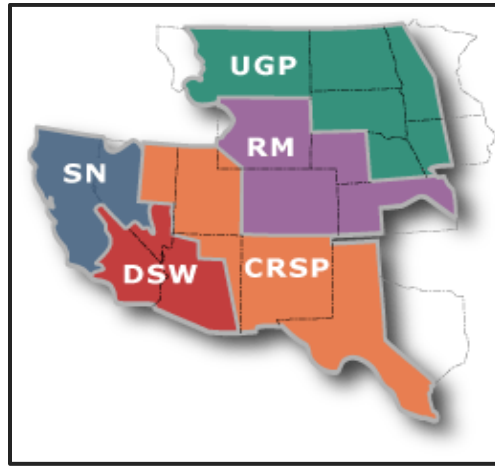
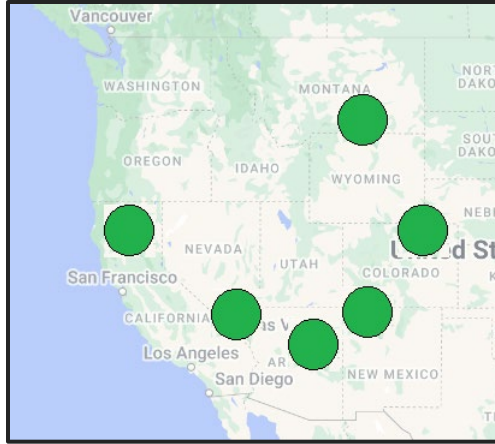

Figure 4-1. WAPA customer service territory

### 4.1 WAPA's Existing Measurement Capabilities Application Evaluation

The synchrophasor measurement placement across the WAPA territory was determined in the last decade. The Peak Reliability Coordinator closure resulted in several changes for WAPA. The Southwest Power Pool began providing RC services to WAPA's eastern region and the associated transmission operators. Sierra Nevada started receiving RC services from the California Independent System Operator. WAPA's own PMU measurements are located across the WAPA customer service territory. Data is captured from eleven different PMUs, illustrated in Table 4-1 and Table 4-2. The approximate geographic and network location of PMUs is shown in Figure 4-2. About a year of PMU data is stored centrally and archived for post-event analysis. Even though some phasor measurements are captured using relays, these relays are dedicated to synchrophasor applications. The control or protection functionalities of these relays are not enabled.



**Figure 4-2. Approximate locations of PMUs across the WAPA customer service territories**

**Table 4-1. Measurement sensor infrastructure in DSW customer service region**

PMU Number	1	2	3	4	5	6	7
Customer service territory	DSW	DSW	DSW	DSW	DSW	DSW	DSW
Bus voltage where PMU is installed	345 kV	345 kV	345 kV	345 kV	345 kV	230 kV	230 kV
Sensor specification	Overcurrent Relay	Overcurrent Relay	Overcurrent Relay	Overcurrent Relay	Overcurrent Relay	Transformer Protection Relay	Transformer Protection Relay
Reporting Rate	30/60 Hz	30/60 Hz	30/60 Hz	30/60 Hz	30/60 Hz	30/60 Hz	30/60 Hz

**Table 4-2. Measurement sensor infrastructure in RM & SN customer service region**

PMU Number	8	9	10	11
Customer service territory	RM	SN	RM	RM
Bus voltage where PMU is installed	230 kV	525 kV	345 kV	230 kV
Sensor specification	Transformer Protection Relay	PMU	Transformer Protection Relay	Transformer Protection Relay
Reporting Rate	30/60 Hz	30/60 Hz	30/60 Hz	30/60 Hz

The WAPA service regions have diverse IBR resources owned by different companies. Multiple measurements such as IBR active/reactive power injection, point of measurement voltages, and currents are captured. However, only a few phasor measurements and point-on-wave measurements are currently captured at the IBR point of measurement. The point-on-wave measurements available at the IBR point of measurement and across the WAPA territory needs further investigation. More than 1 GW of IBR generation is in the interconnection queue, which presents an opportunity to capture phasors or point-on-wave data. Future infrastructure upgrades are identified based on initial analysis. Some of the measurement infrastructure gaps are identified as follows. The following infrastructure upgrades will enable better capture of phasor measurements and point-on-wave data for situational awareness.

- Typically, the data is stored to a compressed binary format and subsequently converted to CSV when further analysis is needed to manage memory. More storage space can enable the archival of data from more sensors.
- Currently, system anomaly events are logged in coordination with the reliability coordinator. However, the visualization of some of the archived data will enable more situational awareness analytics.
- Additional PMU locations could be enabled once appropriate cyber security measures are in place that can effectively protect the critical substation equipment. WAPA is exploring hardware enforced security solutions, such as data diodes, which enable data delivery without introducing an access point to the operational technology environment.

These infrastructure upgrades will enable better situational awareness and more phasor and point on wave measurement data captures. NREL, in coordination with WAPA, has identified three application development activities for WAPA which can enhance its situational awareness and modeling abilities. The following sections describe these three applications in detail.

#### **4.1.1 Oscillation Detection and Mitigation**

Various disturbances and synchronous generator operations in power systems significantly impact stability margins. The ability of a power grid to maintain synchronism following a small disturbance event is critical. The lack of adequate damping torque is the reason for oscillatory instability. Typically low, frequency oscillation can result in inter-area modes or local modes. The proliferation of IBRs results in a displacement of synchronous generation, which reduces system inertia, and inter-area oscillations become a significant challenge. Undamped inter-area oscillations can impose power transfer capacity constraints which may result in a blackout or cascading failure. Many inter-area oscillation events are reported in the literature, including in the WECC area. Therefore, it is essential to dampen the oscillations to ensure a stable operation. Apart from inter-area oscillations, forced oscillation is another crucial phenomenon that is triggered by exogenous disturbances. IBR proliferation can increase the vulnerability of the system to forced oscillation. However, IBRs, if control is adequately designed, can regulate injected power nearly instantaneously to damp out system oscillations. In recent years, several subsynchronous oscillation events have occurred in systems with high penetrations of IBRs (Cheng, 2023). Thus, power oscillation detection and mitigation are crucial. Typically to detect the oscillations, as mentioned in the earlier sections, sub-synchronous oscillations and forced oscillation measurements will require continuous point-on-wave measurement at a reporting rate much above 60 Hz. WAPA has digital fault recorders available on the network, but locations for many are not at the point of interconnections of IBRs. Hence lack of availability of continuous point-on-wave measurement at strategic locations can hinder oscillation detection. Oscillation mitigation necessitates an appropriate design of control architecture. A notional IBR control architecture to damp the oscillations is shown in Figure 4-3.

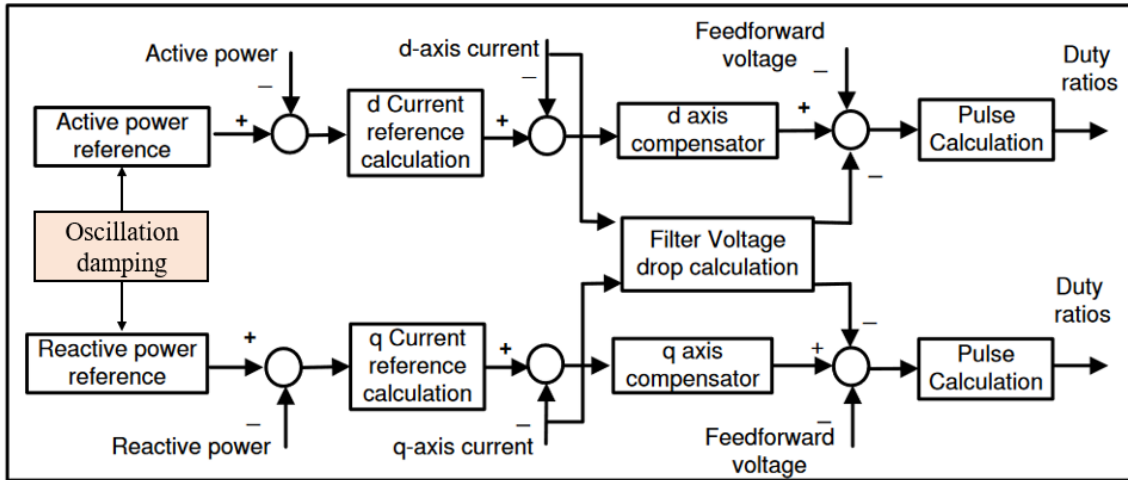

Figure 4-3. Notional IBR oscillation damping control architecture

#### 4.1.2 Disturbance Monitoring

The second application is grid disturbance monitoring capability that can be helpful for WAPA operators. Disturbance monitoring needs PMU measurements and preferably point-on-wave measurements. Having a point on wave or PMU measurements at the point of interconnection of IBR is essential to detect disturbances introduced by IBRs. Also, preferentially disturbance monitoring will need reporting rate much higher than the WAPA reporting rates of (30 Hz/60 Hz). WAPA PMU measurements are continuous, which is essential for monitoring disturbances. However, their locations are only sometimes at the point of interconnection of IBRs.

Generic power system disturbance monitoring requires multiple PMU measurements across the WAPA customer service territory. Currently, eleven phasor measurements are available, as shown in Table 4-1 and Table 4-2. It would be beneficial to capture phasor and point-on-wave measurements from various locations across different WAPA service regions for monitoring disturbances.

#### 4.1.3 Model Validation

A typical power system model validation process is described in Figure 4-4. Model validation is an elaborate process in which the power system model's performance is compared against the practical measurement data. A reduced order model can be tuned considering various simulation and contingency cases. WAPA model validation simulations can leverage the widespread inter-area oscillation mode reported by WECC (WECC, 2020). Further measurements taken at the point of interconnection of the generating facility or measurements taken at the generating unit can be leveraged, as discussed in (WECC, 2021). The existing WAPA PMU data repository can be leveraged, as well. However, more PMU measurements at various WAPA measurement locations and the point of interconnection of the generating facility can ensure a robust model validation.

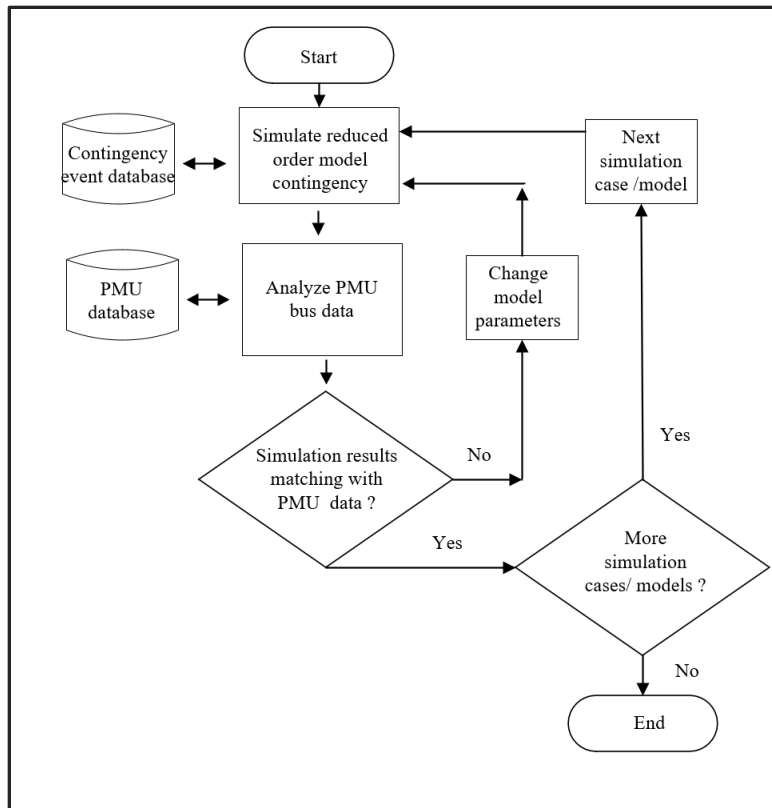

**Figure 4-4. Typical model validation process**

The above applications will be developed leveraging NREL's Advanced Research on Integrated Energy Systems (ARIES) lab facility. A WAPA-specific lab setup development is planned at the NREL. The components of the lab setup are discussed in the next section.

## 4.2 NREL's Live Demonstration Plan

NREL's ARIES consists of a cluster of Digital Real-Time Simulation (DRTS) platforms capable of emulating the power system at various timescales between 50 microseconds and as low as 200 nanoseconds. ARIES also houses advanced grid sensors such as PMUs, power quality metering, data streaming infrastructure, and multi-MW IBRs (hardware for wind turbines, solar PV, and battery energy storage). This provides real-time evaluation capability for a regional-level bulk power grid analysis suitable to WAPA. Specifically, with regards to applications developed above, ARIES can be leveraged as follows.

- **Oscillation detection and mitigation:** WAPA data will allow the NREL team to develop an oscillation mitigation application for real-world WAPA use cases. ARIES setup enables the analysis of multiple oscillations, what-if scenarios, and mitigation strategies. The oscillation detection/mitigation application will be built around NREL's ARIES assets with IBR pads and a network of high-fidelity measurement nodes. Transient measurements from an existing network of PMUs at NREL will aid the analysis. The oscillation detection and mitigation applications will be developed in close coordination with WAPA.
- **Disturbance monitoring:** The present practical measurement repository from WAPA can be leveraged with advanced visualization techniques at ARIES setup to analyze whether existing

measurements can capture disturbances. The large cluster of DRTS simulators at ARIES can also emulate disturbance events.

- **Model validation:** The diverse contingency scenarios can be modeled at ARIES, and results can be compared with the available WAPA PMU data repository to validate WAPA/WECC models. ARIES is an ideal platform to validate WAPA/WECC models.

#### 4.2.1 NREL ARIES Facility

NREL capabilities are comprised of a Multiphysics real time simulation environment with real time simulators for at-scale hardware in the loop testing for wind and solar PV facilities, electrical storage, dynamometers, and controllable grid interface.

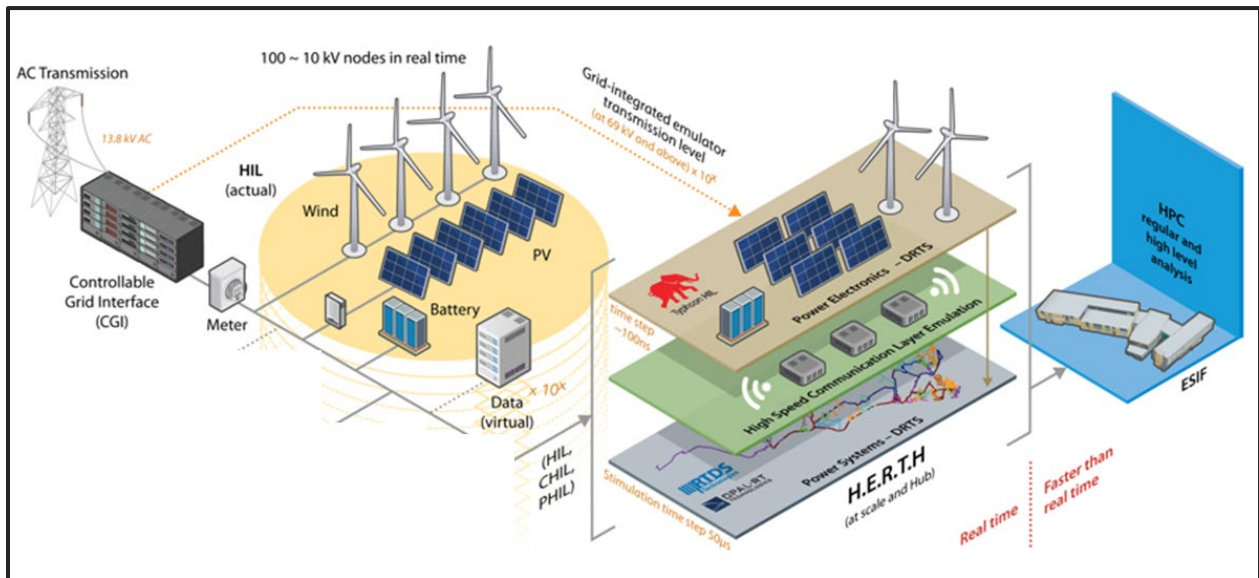

Figure 4-5. NREL's ARIES Facility

The ARIES platform at NREL is composed of a large cluster of Digital Real-Time Simulators (DRTS) as demonstrated in Figure 4-5 to capture Electro-Magnetic Transients (EMT) and Electro-Mechanical interactions. This at-scale transmission level collaborative sensing emulation framework will be capable of large-scale integration of multi-point hardware-in-the-loop (HIL) and testing multiple transmission & distribution nodes in real-time. The DRTS cluster can enable the integration of hardware sensors, such as Phasor Measurement Units (PMUs), relays, etc.

#### 4.2.2 WAPA Data Archive

NREL received nearly 12 Terabytes of data for 11 PMUs for variable periods between 2015 and 2019. The data was passed as CSV, which leads to the data being uncompressed and unwieldy for advanced analytics. NREL is investigating industry-data compression techniques, for instance, converting the files into a parquet format to ensure that backup of the PMU data can be done in a more efficient format. NREL data

archival objective is to provide better analytics of WAPA data. Thus, the pre-processing data activity for the lab setup has the following goals.

- Utilize efficient compression algorithms to store data more compactly. It will help storage infrastructure to be scalable for even larger datasets.
- To ensure easy and faster data processing systems to read and analyze specific data. This will allow for faster queries, streaming into the time series Quasar database.
- To design real-time sensors integration to detect abnormalities in the data streams.

### 4.2.3 WAPA Data Streaming to DRTS

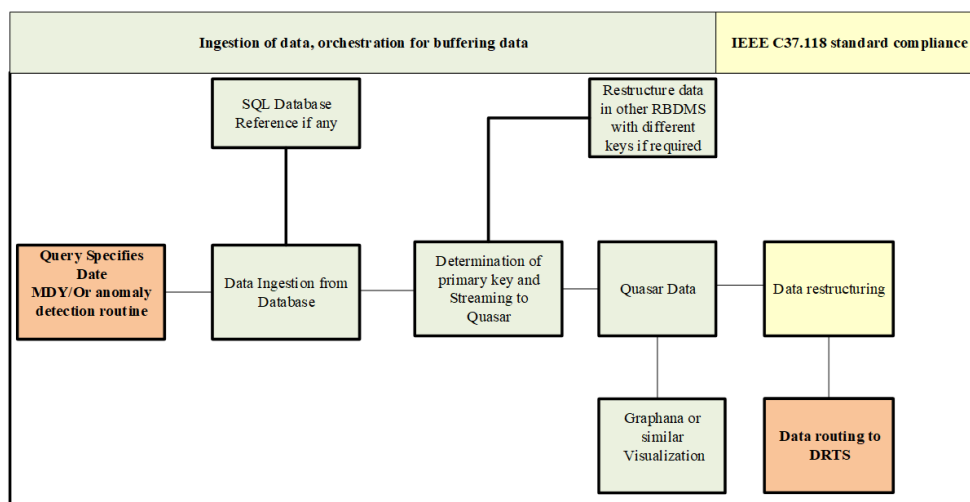

**Figure 4-6. WAPA raw data streaming to DRTS – database management**

The platform can also integrate high-fidelity data, such as that of utility-grade sensor data, as shown in Figure 4-6. ARIES setup can visualize data in real-time for analysis purposes. ARIES also incorporates multiple parameters sensing capabilities with large-scale IP-addressable connected utility sensors. In addition, the DRTS cluster allows the installation of protection hardware, such as utility-grade traveling-wave and phasor-based relays. The cluster can also integrate synchronized waveform measurement devices and non-conventional instrument transformers (e.g., Sample Value-based non-conventional instrument transformers). Overall, the setup can help generate real-world operational data with actual hardware sensors and integrate real-world data generated from external sources. This enables verification and validation of protection and control topologies for fault detection, oscillation monitoring, cascading failure analysis, etc.

To overcome large-scale data ingestion bottlenecks, the ARIES platform stages data in various methods to allow for high-fidelity streaming, as seen in Figure 4-7. Using this data topology, NREL can integrate raw WAPA data at-scale and allow for dynamic changes to telemetry while running at-scale simulations.

Quasar is a software to ingest and query petabytes of data in near real-time, making it very suitable for data collection in large DRTS clusters with multiple interconnected hardware in the loop. Once raw data is ingested and metadata processing is performed, set-up segments telemetry into various Quasar streams. Quasar is an open-source software platform that enables data archival and analysis tools providing high-speed data processing. Quasar enables the segmentation of the data streams to interactive data visualization

components and can readily process it into machine learning methods. Quasar can capture the complete waveform data at the highest resolution directly from various protocols such as MQTT. Within the NREL-ARIES architecture, a Quasar instance setup was deployed and tested at-scale with devices directly communicating with the cluster using different network mediums that support TCP/IP and protocol translators. Additional processing can readily be performed by researchers using the embedded Quasar API. It can be streamed readily to or from the DRTS cluster using various protocols, MQTT, or RAW TCP/IP sockets.

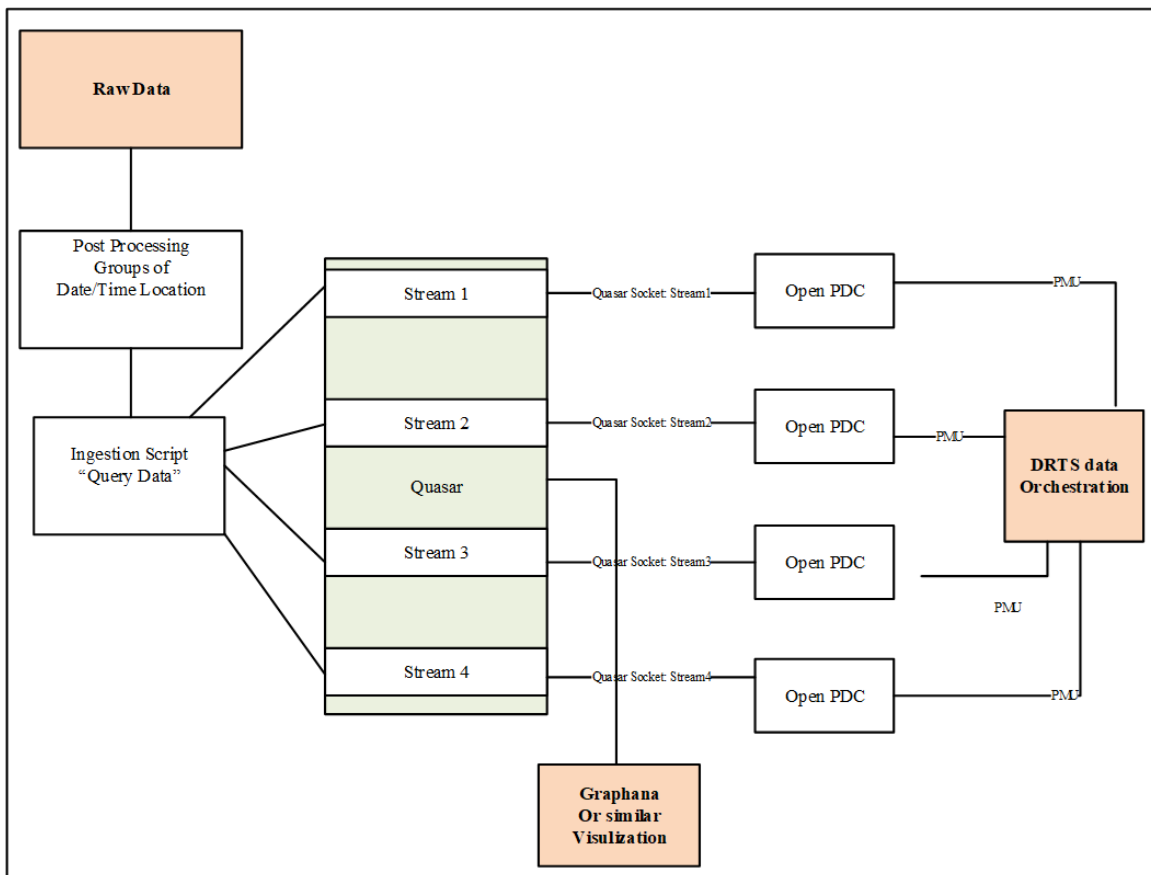

**Figure 4-7. WAPA raw data streaming to DRTS leveraging OpenPDC**

WAPA data can also be leveraged by the other projects while validating some of the oscillation detection and control techniques. OpenPDC (open-source phasor data concentrator) is an ideal software architecture for real-time processing and streaming power system sensor time-series data. This software provides our testbed PMU-specific functionalities, such as PMU data streaming and connection testing. It has the NASPI PMU Registry, a centralized repository from which multiple sensor information can be retrieved. NREL can integrate over one hundred PMUs in a software emulation environment and hardware PMUs combined with a small subset of this architecture seen in Figure 4-8.

Thus, data can be live-streamed in DRTS while leveraging existing PHIL and at-scale transmission setup at ARIES. Using real-time sensor data, this ARIES setup will enable researchers to evaluate transmission stability, oscillations, and various blackout prevention scenarios. WAPA data archival and its ingestion with DRTS will be a valuable lab setup enabling real-time modeling of several utility use cases.

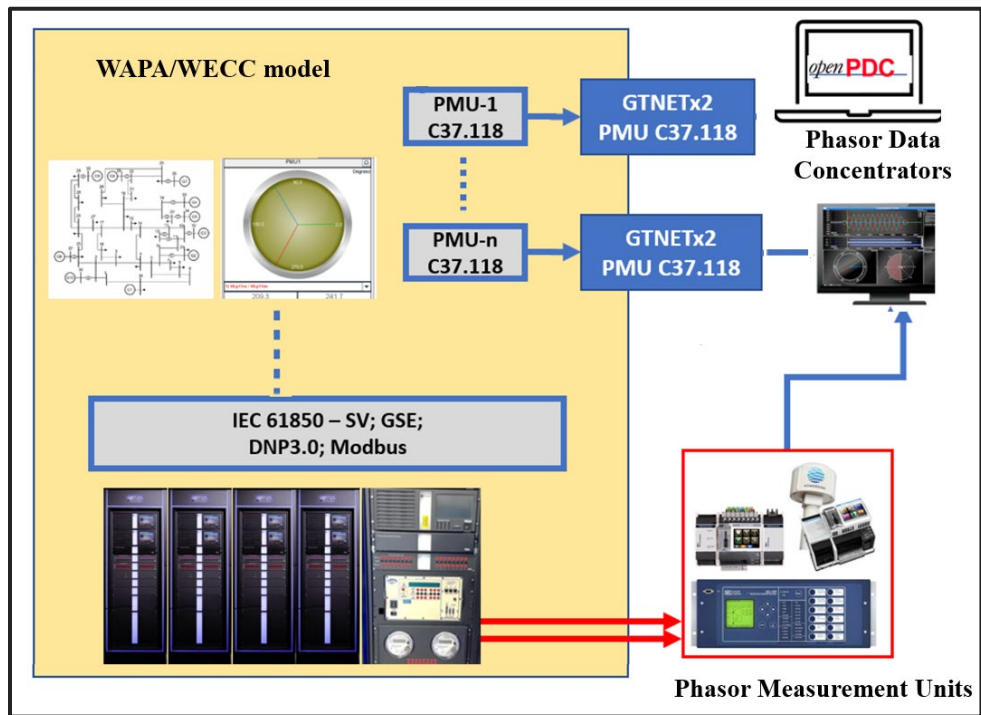

Figure 4-8. WECC reduced order model and CHIL interface of the PMUs.

## 5.0 Research Gaps

The gaps discussed in the previous three chapters focused on the limitations of existing measurement systems operated by the project's utility partners. This chapter provides a discussion of additional gaps related to the research being performed in this space.

In reviewing the literature to identify measurement-based IBR applications, it became clear that many researchers do not account for measurement accessibility when designing and testing their applications in simulation. Researchers tend to develop and test algorithms assuming that measurements from ideal locations are available. This is reasonable for early-stage research, but it limits the transferability of that research to practical use. For an application to be practical, it needs to provide value to an organization that has access to the necessary measurements. An application that requires measurements from an IBR plant's POC is not necessarily valuable to the plant operator. Even if the application has value for the transmission system operator, the POC measurements are likely unavailable. Researchers need to better understand and articulate who will benefit from their proposed application and what measurements are available to their user.

One of the factors impacting the availability of advanced measurements is data sharing. The barriers to collecting waveform measurements from within an IBR plant are relatively low. However, even if the measurements exist, there are barriers to making the measurements available to transmission system operators. The hesitancy for IBR plant owners to share detailed models for fear of disclosing proprietary information is well known, and this hesitancy extends to waveform measurements. Without a solid value proposition or requirement from the transmission system operator, these measurements will not be shared.

Whether the waveform measurements are collected by the plant at the POC or by the system operator at the POI, their continuous streaming poses significant challenges. Strong business cases are needed to justify significant investments in instruments, network management, security, and archiving tools. Laboratory demonstrations can help build this business case, but for the next several years field demonstrations and utility deployments will need to leverage practical alternatives to continuously streaming POW measurements. For example, hybrid applications could rely primarily on synchrophasors and analyze short POW records as necessary.

In the area of advanced power system measurements, waveform measurements have received significant attention from researchers in recent years. Another recent area of emphasis for researchers is the application of artificial intelligence and machine learning (AI/ML) methods to analyze power system measurements. Though promising results have been generated, the lack of labeled event data remains a limiting factor. Researchers tend to expect utilities to carefully associate detailed event descriptions with measurements, but this is not a task that utilities have been motivated to perform. If the value proposition for AI/ML methods is strong enough for utilities to begin labeling event data, tools are needed to make the task efficient.

## 6.0 Conclusion

The integration of IBRs into the nation's power system is critical to achieving the nation's clean energy goals. The processes and tools needed to maintain the BPS reliability in the midst of this transformation span many aspects of power system planning and operation. Advanced measurement systems are one capability that utilities can use to support IBR integration. During the first year of the PROGRESS MATRIX project, the laboratory team examined opportunities presented by measurement-based applications and the gaps that currently limit their deployment.

Transmission system operators are currently limited in the measurement-based applications available to them based on measurement type, location, and availability. Synchrophasors are widely deployed in transmission substations and report measurements continuously. Much can be accomplished with these measurements, but the phasor representation of voltage and current waveforms omits details needed for IBR applications such as root cause analysis and oscillation detection. Waveform measurements can provide the detail lacking in synchrophasors, but at present most POW measurements are collected for short durations based on predefined triggers. Communication and storage costs limit utilities in making these measurements more broadly available. Whether based on PMU or POW measurements, IBR applications that depend on measurements from an IBR plant's point of connection are more difficult for transmission operators to implement than those depending on measurements from transmission substations.

Despite these challenges, there are several opportunities to develop and demonstrate measurement-based IBR applications. In the coming year, each laboratory involved in the PROGRESS MATRIX project will demonstrate how advanced measurement systems can be used to better integrate IBRs. These demonstrations will be performed with consideration of measurement system limitations to improve the practicality and value proposition for transmission system operators. As researchers better address limitations with practical solutions, utilities will be better able to adopt the measurement technologies and applications that will lead to accelerated adoption of IBRs and improved reliability and resilience of the bulk power system.

## 7.0 Bibliography

- AESO. (2022). *DER Anti-islanding Screening and Study Guideline*. Retrieved from [https://www.aeso.ca/assets/DER-Anti-islanding-Screening-and-Study-Guide\\_FINAL.pdf](https://www.aeso.ca/assets/DER-Anti-islanding-Screening-and-Study-Guide_FINAL.pdf)
- Anti-Islanding Protection with Grid-Tied PV Inverters*. (2023, Feb 28). Retrieved from [solectria.com](https://solectria.com/blog/anti-islanding-protection-with-grid-tied-pv-inverters/): <https://solectria.com/blog/anti-islanding-protection-with-grid-tied-pv-inverters/>
- Ashton, P. M., Saunders, C. S., Taylor, G. A., Carter, A. M., & Bradley, M. E. (2015). Inertia Estimation of the GB Power System Using Synchrophasor Measurements. *IEEE Transactions on Power Systems*, 701-709.
- BPA. (2016, July). *Keeping the way clear for safe, reliable service*. Retrieved from Bonneville Power Administration: <https://www.bpa.gov/-/media/Aep/lands/lusi-Keeping-the-way-clear-for-safe-reliable-service.pdf>
- Cheng. (2023, January ). Real-World Subsynchronous Oscillation Events in Power Grids With High Penetrations of Inverter-Based Resources. *IEEE Transactions on Power Systems*, 38(1), pp. 316-330,. Retrieved from <https://ieeexplore.ieee.org/>
- Cheng, Y., Fan, L., Rose, J., Huang, S.-H., Schmall, J., Wang, X., . . . Zhou, J. (2023). Real-World Subsynchronous Oscillation Events in Power Grids With High Penetrations of Inverter-Based Resources. *IEEE Transactions on Power Systems*, 316-330.
- da Cunha Lima, A., Luis do N. Severo, A., Menegazzo, L. F., Michels, L., Marquioro de Freitas, C., Andrade Mourinho, F., & de Bitencourt, I. A. (2021). Challenges for Loss-of-Mains Protection System in Inverter-Based Resources Applications. *Brazilian Power Electronics Conference (COBEP)* (pp. 1-8). IEEE.
- Fan, L., & Miao, Z. (2020). Time-domain measurement-based  $dq$ -frame admittance model identification for inverter-based resources. *IEEE Transactions on Power Systems*, 2211-2221.
- Fan, L., Miao, Z., Shah, S., Koralewicz, P., Gevorgian, V., & Fu, J. (2022). Data-Driven Dynamic Modeling in Power Systems: A Fresh Look on Inverter-Based Resource Modeling. *IEEE Power and Energy Magazine*, 64-76.
- Follum, J. D., Wang, H., Etingov, P. V., Tuffner, F. K., Agrawal, U., Huang, Z., . . . Heredia, E. M. (2018). *Archive Walker Software: Setting Up and Reviewing Analyses with the Archive Walker GUI*. PNNL-28016.
- Hart, P. J. (2022). Provably-Stable Overload Ride-Through Control for Grid-Forming Inverters Using System-Wide Lyapunov Function Analysis. *IEEE Transactions on Energy Conversion* 37, 2761-2776.
- Hatzargyriou, N., Milanovic, J., Rahmann, C., Ajarapu, V., Canizares, C., Erlich, I., . . . Vournas, C. (2021). Definition and Classification of Power System Stability – Revisited & Extended. *IEEE Transactions on Power Systems*, 3271-3281.
- Huang, S.-H. J. (2012). Voltage control challenges on weak grids with high penetration of wind generation: ERCOT experience. *IEEE Power and Energy Society General Meeting* (pp. 1-7). IEEE.
- IEEE. (2022). *IEEE Standard for Interconnection and Interoperability of Inverter-Based Resources (IBRs) Interconnecting with Associated Transmission Electric Power Systems*.
- Jayasinghe, G. a. (2021). *Stability-Enhancing Measures for Weak Grids Study*. ARENA. *Kaua'i Island Utility Cooperative*. (2023, March 3). Retrieved from <https://www.kiuc.coop/>
- Kroposki, B. (2016). *Prevention of unintentional islands in power systems with distributed resources*. No. NREL/PR-5D00-67185. Golden, CO (United States): National Renewable Energy Lab (NREL).
- Lingwei Zhan, J. Z. (2015). Universal Grid Analyzer Design and Development. *IEEE Power and Energy Society General Meeting* (pp. 1-5). Denver: IEEE.
- NASPI. (2022). *NASPI-NERC Joint Technical Workshop Inverter Based Resource*. Retrieved from <https://www.naspi.org/node/960>

- NERC. (2018). *BPS-Connected Inverter-Based Resource Performance*. Retrieved from [https://www.nerc.com/comm/RSTC\\_Reliability\\_Guidelines/Inverter-Based\\_Resource\\_Performance\\_Guideline.pdf](https://www.nerc.com/comm/RSTC_Reliability_Guidelines/Inverter-Based_Resource_Performance_Guideline.pdf)
- NERC. (2020). *Recommended Disturbance Monitoring for Inverter-Based Resources*. NERC Synchronized Measurements Subcommittee (SMS).
- Photovoltaics, D. G. (2018). *IEEE standard for interconnection and interoperability of distributed energy resources with associated electric power systems interfaces*. IEEE Std 1547: 1547-2018.
- Tuttelberg, K., Kilter, J., Wilson, D., & Uhlen, K. (2018). Estimation of Power System Inertia From Ambient Wide Area Measurements. *IEEE Transactions on Power Systems*, 7249-7257.
- Vandenberghe, F. E. (2004). *FINAL REPORT of the Investigation Committee on the 28 September 2003 Blackout in Italy*. UCTE, Tech. Rep.
- WAPA. (2023). *WAPA Customer service territories*. WAPA. Retrieved from <https://www.wapa.gov/regions/Pages/service-map.aspx>
- WECC. (2020). *WECC Generating Facility Data, Testing and Model Validation Requirements*. <https://www.wecc.org>.
- Xu, W., Huang, Z., Xie, X., & Li, C. (2022). Synchronized Waveforms – A Frontier of Data-Based Power System and Apparatus Monitoring, Protection, and Control. *IEEE Transactions on Power Delivery*, 3-17.





<http://gridmodernization.labworks.org/>