

Design and implementation of a prototype infrared video bolometer (IRVB) in MAST Upgrade

Fabio Federici,^{1,2,3, a)} Matthew L. Reinke,^{2,4} Bruce Lipschultz,¹ Andrew J. Thornton,³ James R. Harrison,³ Jack J. Lovell,^{2,3} Matthias Bernert,⁵ and the MAST Upgrade team^{b)}

¹⁾*York Plasma Institute, Department of Physics, University of York, Heslington, York, YO10 5DD, United Kingdom*

²⁾*Oak Ridge National Laboratory, Oak Ridge, Tennessee 37831, USA*

³⁾*United Kingdom Atomic Energy Authority, Culham Centre for Fusion Energy, Culham Science Centre, Abingdon, Oxon, OX14 3DB, United Kingdom*

⁴⁾*Commonwealth Fusion Systems, Cambridge, MA 02139, USA*

⁵⁾*Max Planck Institute for Plasma Physics, EURATOM Association, D-85748 Garching, Germany*

A prototype infrared video bolometer (IRVB) was successfully deployed in the Mega Ampere Spherical Tokamak Upgrade (MAST Upgrade or MAST-U), the first deployment of such a diagnostic in a spherical tokamak. The IRVB was designed to study the radiation around the lower x-point, another first in tokamaks, and has the potential to estimate emissivity profiles with spatial resolution beyond what is achievable with resistive bolometry. The system was fully characterised prior to installation on MAST-U and the results are here summarized. After installation, it was verified that the actual measurement geometry in the tokamak qualitatively matches the design; this is a particularly difficult process for bolometers and was done using specific features of the plasma itself. The installed IRVB measurements are consistent both with observations from other diagnostics including magnetic reconstruction, visible light cameras and resistive bolometry, as well as the IRVB designed view. Early results show that with a conventional divertor geometry and only intrinsic impurities (for example C, He), the progression of radiative detachment follows a similar path to that observed for large aspect ratio tokamaks: The peak of the radiation moves along the separatrix from the targets to the x-point and high field side midplane with a toroidally symmetric structure that can eventually lead to strong effects on the core plasma inside the separatrix.

I. INTRODUCTION

The management of the heat from the fusion reaction is a critical aspect for the design of future tokamak power plants. Of the energy from fusion reactions about 1/5 is released to the core plasma. When this leaves the core it is directed to the solid surfaces of the target via a very thin layer of plasma, with width of the order of few mm^{1,2}, leading to heat fluxes of the order of 10GW/m².³ To keep the heat flux below engineering limits (of the order of 10MW/m²)⁴ simulations show that for ITER a reduction of a factor of 100 near the separatrix can be achieved thanks to atomic processes like excitation/line radiation, charge exchange, and recombination.⁵ To further reduce the heat flux detachment a state in which the plasma recombines in the volume before reaching solid surfaces is expected to be employed.⁶ When these conditions are achieved it is expected that a large fraction of the fusion and auxiliary heating power will be dissipated by the plasma in the form of radiation. The location of the radiating regions can have a significant impact on the core plasma⁷ therefore it is important to well characterise the power balance and radiated power profile in current machines to understand the stability and performance of strongly radiating plasmas and support predictions for future devices. Key diagnostics are bolometers that usually operate by exposing a thin foil to plasma radiation and by

monitoring its temperature. The subject of this paper is a prototype infrared video bolometer (IRVB) installed on the Mega Ampere Spherical Tokamak Upgrade (MAST-U) to study x-point and divertor radiation. The IRVB concept has previously been demonstrated on tokamaks (Alcator C-Mod⁸, HL-2A⁹, JT-60U¹⁰, KSTAR^{11,12}) and stellarators (LHD^{13,14}, Heliotron J¹⁵) and its basic operating principles are well known. A thin foil is exposed to the plasma radiation through a pinhole aperture so that each point of the foil corresponds to a different line of sight (LOS). The foil heats up according to the radiation it receives and the change in foil temperature is measured via an infrared camera. The advantage, relative to discrete resistive bolometer sensors¹⁶, lies in the very large number of LOS accessible with a single IRVB device and the capability to image very large or small portions of the plasma based on foil and pinhole relative position. The foil is also a completely passive component, potentially better resistant to neutron irradiation therefore more reactor relevant, than in a resistive bolometer, where on the foil is glued the active resistors used to measure its temperature. The downsides are that the physics of thermal diffusion needs to be considered which introduces a limit in the time resolution of the diagnostic. The IRVB technique is not new, but the current application in MAST-U represents the first successful implementation on a spherical tokamak. Additionally, in most cases, the IRVB is tuned to image the core plasma, while in this case the aim is to measure the radiated power profile in the vicinity of the lower x-point with high resolution. This choice also comes from the need to complement the MAST-U resistive bolometry system with a radiated power diagnostic with high resolution in a region of the plasma characterised by sharp variations. This paper will

^{a)}The author to whom correspondence may be addressed: fabio.federici@york.ac.uk

^{b)}See author list of "J. Harrison et al 2019 Nucl. Fusion 59 112011 (<https://doi.org/10.1088/1741-4326/ab121c>)

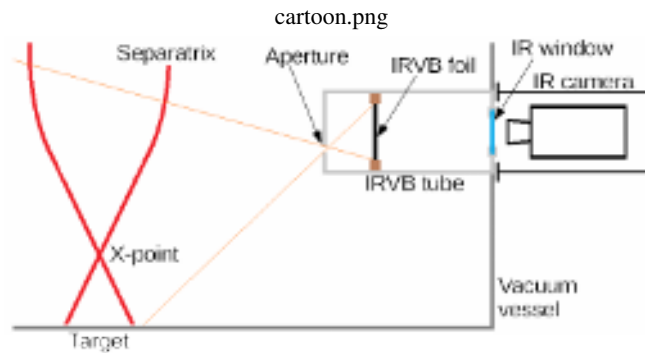

FIG. 1: Schematic representation of the main components of a IRVB diagnostic

detail the considerations that dictated this prototype design. The entire calibration procedure and the lessons learned from this implementation will also be presented. Early results from the first experimental campaign in MAST-U (MU01) will be shown.

II. IRVB BASICS

A sketch of the IRVB in MAST-U is in Figure 1.

There are various elements to consider in the design of the IRVB diagnostic as shown in Figure 1. Considering how thin a typical carbon coated foil is (composed of $10\mu\text{m}$ graphite + $2.5\mu\text{m}$ platinum + $10\mu\text{m}$ graphite as per¹⁷ and their standard properties), when the temperature on one side is increased by a set amount it takes $\sim 7\text{ns}$ for the other side to reach the 99% of that increase. The heat transfer across the foil is so fast compared to the maximum frame rate of the infrared (IR) cameras available (tens of kHz) and the timescale of the phenomena of interest (1-10ms) that it permits treating heat diffusion as a 2D problem. The thinner the foil the lower the thermal inertia, allowing for a higher temperature rise for given input power. The thickness must nevertheless be large enough for the vast majority of the radiation to be absorbed. The foil must also (if a significant amount of neutrons are produced by the plasma) be made of a material weakly prone to neutron induced transmutation and vacuum compatible.¹⁸ It is important that the foil has low reflectivity for the wavelength range of interest. Metals normally used in bolometers have low reflectivity for UV and shorter wavelengths, but high for longer as the majority of radiation from the plasma is emitted at VUV wavelengths. This is usually addressed by coating the foil with a thin layer of carbon (as done in our case), known as "blackening", that weakly absorbs and weakly reflects high energy photons but has low reflectivity and high absorption at low energies. The coating does not significantly impact the reflectivity of radiation entering the diagnostic at shallow angles and reaching the foil supports.¹⁹ This light would require multiple reflections to reach the foil and would, therefore, be scattered resulting in a weak offset in a large portion of the foil. This would not change its capability to observe sharp features from the plasma. The coating introduces an interface between ma-

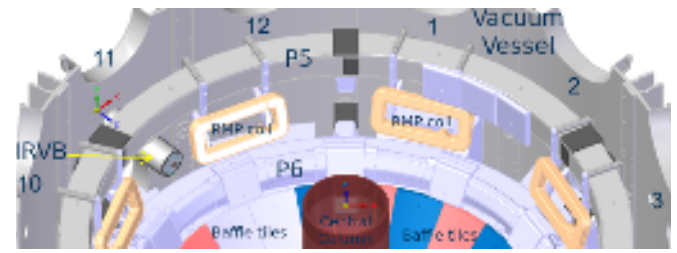

FIG. 2: Top view of the lower half of MAST-U, showing the positioning of the IRVB inside the vacuum vessel respect to other features. The numbers identify the sectors, assigned clockwise in the toroidal direction.

terials that might impede heat transfer and increases the mass of the foil increasing its inertia. The coating could also, depending on the technique, be deposited non uniformly on the foil, adding to the non uniformity already present on the foil. The coating must also be stable and vacuum compatible.²⁰

The infrared camera must be positioned as close as possible to the foil in order to increase the resolution and signal to noise ratio. If the neutron flux is significant, or there are mechanical constraints, mirrors or periscopes must be used. All apparatus must be suitable to transmit infrared radiation and properly coated to avoid reflections. The camera itself has to be suitable for measuring temperature differences of few K around room or vacuum vessel temperature. Of great importance in the design is the positioning and size of the pinhole aperture with respect of the foil. The distance and position impacts the field of view (FOV) of the diagnostic, its spatial resolution and the radiation intensity.

III. MAST-U IRVB DESIGN

The IRVB design is based on work previously done for NSTX-U²¹ and here it will be shown how the design was adapted to the specific geometry of MAST-U. The vertical location of the IRVB was dictated by the available ports on the machine. The one assigned to the IRVB is HE11-2, located in sector 11 and centered 0.7m below the midplane. The pinhole was placed as close as possible to the plasma to enable an unobstructed, wide field of view while being protected by the surrounding structures and safely outside the plasma scrape-off layer (SOL), at a radius of 1.55m . The resulting positioning of the IRVB tube can be seen in Figure 2.

With the above constraints, the pinhole was located off the centre of the foil so that the the LOS starting from the x-point in the poloidal view of the plasma would land in the centre of the foil. Two-thirds of the foil surface will have a mostly poloidal view of the plasma, while one-third will have a mainly tangential view. The foil is composed of a $2.5\mu\text{m}$ platinum film coated with graphite on both sides of dimensions $9 \times 7\text{cm}$ as supplied by the National Institute for Fusion Science (NIFS), with the longer side aligned with the vertical axis of the machine to provide a large coverage in that direction. An exploded view of the components and their final

appearance are shown in Figure 3 and Figure 4 respectively. In the design of the assembly, particular care was dedicated to:

1. The presence on the re-entrant and air side section of the diagnostic of features that can be used to align the view with the MAST-U geometry as intended.
2. The mechanical rigidity of the assembly and the increase of magnetic permeability due to welds. The tube has a weld along its length that was heat treated to reduce the relative magnetic permeability below 1.05.
3. Blackening all the surfaces that could cause reflections and direct light to the foil. The entire detector sub-assembly was blackened with Moly-Paul powder in an isopropanol solution (the same used within the MAST-U vacuum vessel (VV)) while it was deemed sufficient to grit blast the other surfaces.
4. The presence of cutouts in the tube to equalise the pressure within. The effect of rapid pressure changes was tested on a dummy foil created for this purpose in the benchtop setup (see Figure 15) causing no motion of the foil with depressurization of up to 0.05bar/s (only cooling due to ambient air decompression) and visible motion but no damage up to 0.2bar/s .
5. Maintaining electrical isolation between the tube and the absorber assembly (foil and copper plates) with PEEK isolation washers to avoid eddy currents through the absorber.
6. Use of vented screws for tapped holes to avoid trapping air and slowing down the vessel pump down.

The power density on the foil was estimated with CHERAB^{22–24}, a code that can perform ray tracing with the full geometry of MAST-U. Based on prior experience with the IRVB on NSTX-U²⁵, the noise equivalent power density (NEPD) is expected to be in the region of $\sim 5\text{W/m}^2$, and so a desired signal of $\sim 100\text{W/m}^2$ was utilized in the pinhole camera design.

The power distribution on the foil was also simulated in the case of a core and divertor region filled with a homogeneous emitter.²⁶ See Figure 5.

The bottom left region of the image is where no radiation can arrive. This could have been helpful for the prototype phase, because that area could have been used as a reference where the power is zero. For this reason it has been decided to adopt a stand-off between pinhole and foil distance of 45mm for MU01, which covers results shown in this manuscript. This allows for an intense enough radiation from the X-point to adopt a relatively small 4mm diameter pinhole, allowing for better resolution. In Figure 6 it is illustrated how, with a smaller pinhole, the signal level is lower but it is easier to identify close but distinct structures in the radiation distribution, even from the poloidal view alone (left side of the foil). For closer radiating structures it would be easier to distinguish them as separate in the tangential view (right side of the foil) with a smaller rather than large pinhole. The MAST-U IRVB

diagnostic has been returned to operation on MAST-U for the second campaign (MU02) with a stand-off of 60mm which enables higher spatial resolution within the divertor region.

An approximate view inside MAST-U, imagining that the IRVB operates as a camera to show the features and obstructions, is shown in Figure 7. The view of the plasma is mainly poloidal on the left side of the central column, but the field of view is large enough to see both sides of the central column.

Figure 8 displays the overlap between the coverage and views of the resistive bolometry system and that of the IRVB. The core resistive bolometer LOSs are mostly suited to measure the fairly homogeneous core emissivity profiles on a flux surface, as there is no overlap between the various LOS. The super-x chamber has a good coverage, but only between the x-point and the entrance to the divertor defined by the baffle. The IRVB is aimed to fill the gap between the two systems.

The assembly holding the foil is composed by a $2.5\mu\text{m}$ thick platinum foil from Nilaco, Japan, held between oxygen free copper plates and was originally prepared by NIFS. The foil is the same as that used in Alcator C-mod⁸ where it is described in more detail. The foil thickness is optimised to stop photons with energies up to 8.2keV .^{14,19} The foil and its support frame have been spray blackened on both sides with Aerodag® G Graphite Aerosol and calibrated with a procedure analogous to the one described in²⁸. The layer of graphite helps to absorb radiation in the visible range, avoiding reflection; even if its thickness is larger than the platinum layer¹⁷ it should be thermally irrelevant.²⁹ Lower energy photons like visible light represent a minor energy loss channel, but their relevance is expected to increase in deeply detached and cold plasmas, therefore the importance of the coating.³⁰ In²⁰ it is shown that this type of coating causes irregularities in the foil, leading to non uniform temperature increases. To alleviate this issue, the carbon layer can be deposited with a vacuum evaporation technique that guarantees reproducibility and uniformity, as done at LHD.²⁰ Given the prototype nature of the present implementation and the availability of a vacuum compatible certified absorber, this foil was deemed sufficient.

To guarantee consistency in the positioning and orientation of the foil with respect to the pinhole, a series of markings were inscribed by NIFS on the copper plates as shown in Figure 9. The yellow numerical markings are also used to define the thermal calibration supplied with the foil. The compatibility of the assembly with the thermal expansion caused by the MAST-U VV bake was studied. The bake causes the VV and internal components to reach $\sim 110^\circ\text{C}$ and 120 to 200°C respectively, likely causing the absorber assembly to reach an intermediate temperature. The thermal expansion coefficients for Cu and Pt are $16\mu\text{m/mK}$ (similar to steel) and $9\mu\text{m/mK}$ respectively. This could have led to stress and thus tearing of the foil, but confidence was gained with the pressure test mentioned in Section III on the mechanical resilience of the foil. Another item of concern related to the bake is the stability of the carbon coating on the absorber foil. The technical datasheet for Aerodag® G used for coating, indicates that it can be used as lubricant up to 200°C . Considering the possible failure modes, any piece of carbon detaching from the absorber assembly was expected to stay within the tube, pos-

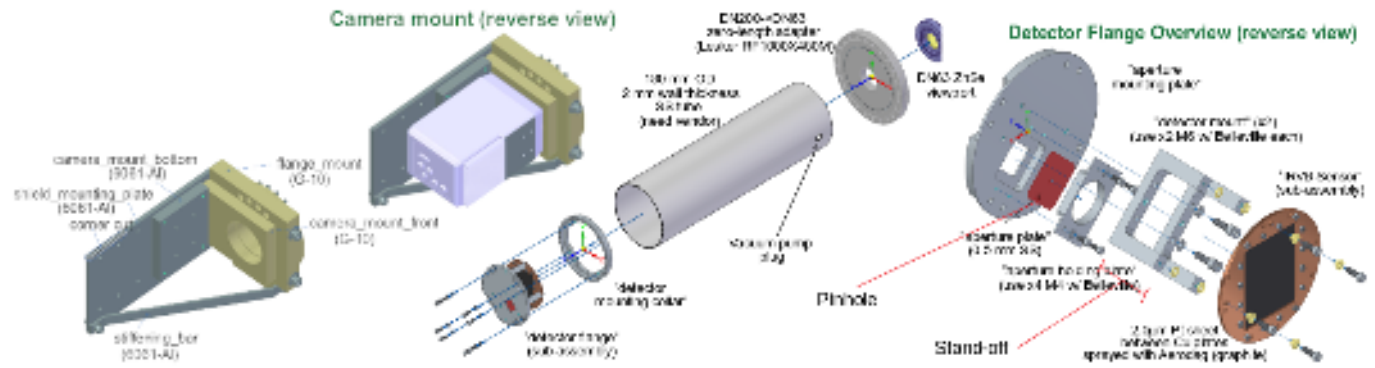

FIG. 3: IRVB components overview: exploded view showing all internal components before welding and assembly.

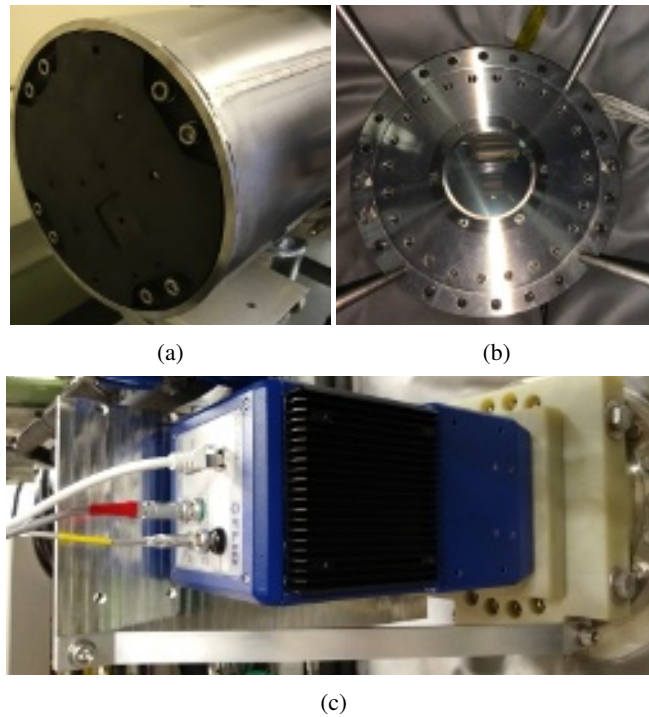

FIG. 4: IRVB components overview: (a) photograph of the foil assembly inside the tube, (b) the view port side of the tube installed in MAST-U and (c) the camera installed on the flange respectively. Photographs taken 2018/07/23, 2018/12/03, 2021/05/14 respectively. To change pinhole size and foil pinhole distance the tube must be removed while the camera is always accessible.

ing no risk for MAST-U operations. The IRVB has ultimately undergone the entire bake cycle prior to MU01 and after inspection did not seem to suffer any damage.

The tube where the foil is installed extends from the vacuum chamber wall to a position close to the plasma, but still safely outside the SOL and potential particle and power loads. The camera images the absorber foil through a 10mm thick ZnS view port from Crystran with 4 – 5 μm and 8 – 10 μm anti reflection coating on both sides and is bolted to the tube. The

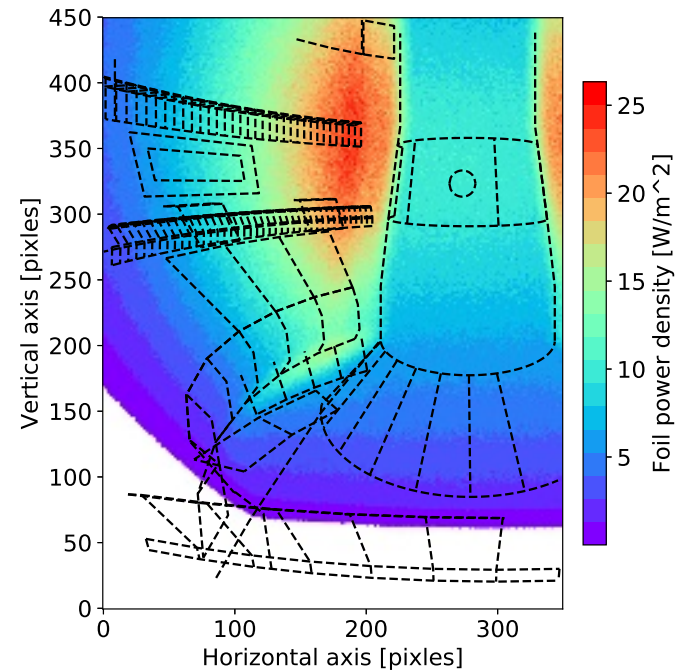

FIG. 5: Radiated power deposited on foil with a 4mm diameter pinhole and 45mm stand-off between pinhole and foil, for the case of the core and divertor regions emitting homogeneously at a level of 50kW/m³. The white region does not receive any radiation from the plasma, in black are overlaid the projection of relevant features of MAST-U structure on the foil for reference.

orientation of the view port with respect to the camera, even if it should not matter substantially, was maintained throughout the test and assembly phases for consistency. The view port assembly was leak checked before final installation with the setup in Figure 15. The camera, a FLIR SC7500 with InSb detector array, is equipped with a 4 – 5 μm pass band filter and has a spectral range of 1.5 – 5.1 μm . This model was selected so that the same could be adopted for other diagnostics in MAST-U and the same acquisition software could potentially be developed. This is inconvenient for the IRVB, as the optimal wavelength for a black body radiator around room

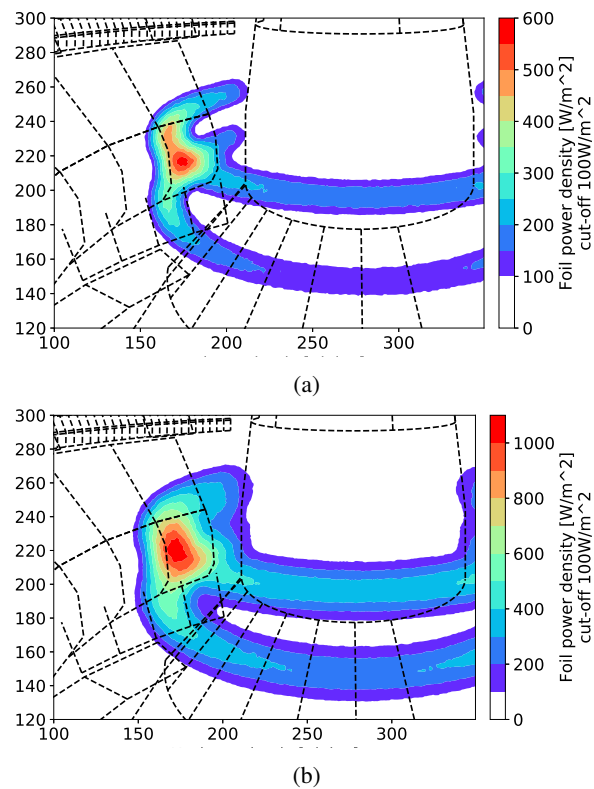

FIG. 6: Radiated power deposited on foil, modeled with CHERAB, of two toruses of 4 cm minor radius separated by 16cm in vertical position with uniform emissivity such as to total 0.5MW of radiated power, located at the expected x-point location. The pinhole size was varied from 4mm (a) to 6mm (b) to illustrate the loss of spatial resolution. The power deposited on the foil below $100W/m^2$ is not shown, as that is the minimum desired signal level. Only the relevant section of the foil is shown. In black are overlaid the projection of relevant features of MAST-U structure on the foil for reference.

temperature is around $10 - 14\mu m$. Considering that the volume between foil and camera is fully enclosed in the IRVB tube and that the temperature of the entire assembly does not deviate appreciably from room temperature during the short duration of the pulse, the use of the filter would not have prevented any stray light to effect the measurements. For this reason the camera was used without the internal filter, increasing the signal. At the maximum frame rate at full frame (383Hz) and 2ms integration time a strong signal around 11000 counts is measured (see Figure 13) with saturation at $2^{14} = 16384$ counts and a noise floor ~ 5 counts. During testing a design flaw of the present IRVB design was discovered. It became clear that, even with the presence of the anti reflection coating, the view port caused the so-called "narcissus effect". This happens when the camera can see its own reflection on the view port, hence "narcissus". The view is orthogonal to the camera FOV, so at its center is the image of the reflection of the sensor array. The detector array is cooled to about $-203^\circ C$, while around it the body of the camera is slightly

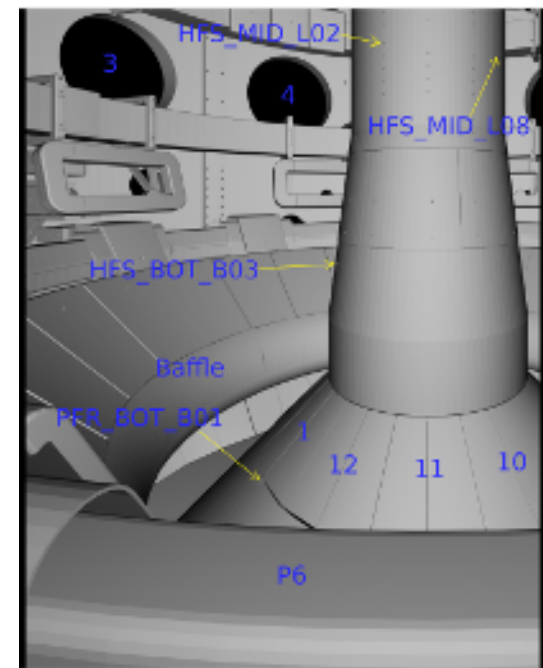

FIG. 7: Approximate view inside MAST-U as if the IRVB operates as a camera. Blue labelling is used to highlight the various sectors and the fuelling locations in the IRVB field of view (FOV). At the bottom of the image is the coil P6 obstructing the field of view.

above room temperature. This causes a "dark spot" to appear at the centre of the image. The main difficulty in dealing with the effect arises from the inability to perfectly match the orientation of the view port during calibration and on the machine. Ultimately this systematic error, if stable intra-shot, does not effect the temporal and spatial temperature derivatives on which the analysis primarily relies. In future iterations of the diagnostic, the view port should be angled with respect to the camera so as to reflect light from an area with a more homogeneous temperature and emissivity.

The camera is bolted to aluminum plates cantilevered off an insulating G-10 piece that is connected directly to the vacuum vessel flange (to stop induced current loops) as shown in Figure 4. The aluminum plates holding the camera have multiple holes so that the camera can be located at 4 fixed distances from the the view port (8.7, 11.2, 13.7, 16.2cm), with the closest being the one with the foil in focus. The ability to vary the camera location allowed us to progressively test the compatibility of the camera with magnetic field. That data was collected during the commissioning phase of the MAST-U magnets while the camera was first as far as possible from the VV. Once the maximum field was reached the camera was then progressively moved towards its final position whilst checking that no anomalies in its operation arose. The camera operated normally at all distances, making a magnetic shield around it unnecessary.

This is the author's peer reviewed, accepted manuscript. However, the online version of record will be different from this version once it has been copyedited and typeset.
PLEASE CITE THIS ARTICLE AS DOI: 10.1063/1.50128768

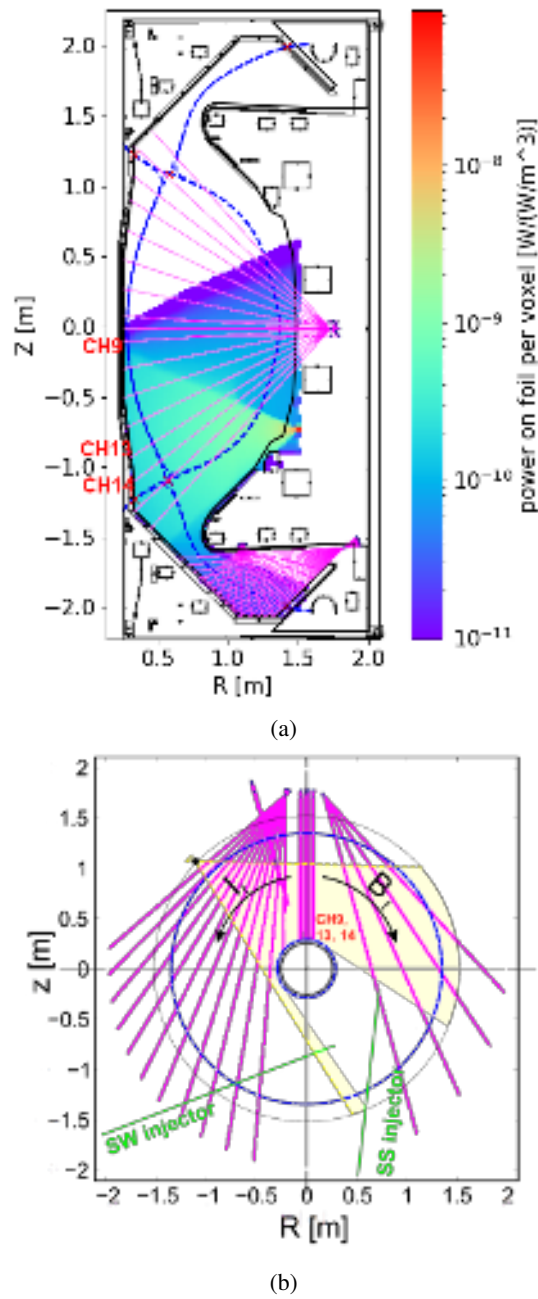

FIG. 8: (a) Poloidal view of MAST-U showing the comparison of the resistive bolometer system LOS (magenta) with a color plot obtained by scanning all the voxels with a $1\text{W}/\text{m}^3$ emitter and integrating the power absorbed by the foil, indicating the regions of higher sensitivity of the IRVB. (b) Top view of MAST-U showing the position of neutral beam injectors (NBI, green), of the co- and counter-NBI resistive bolometer LOSs and the IRVB FOV (yellow, mostly counter-NBI). Adapted from²⁷. For reference the separatrix of a typical plasma is shown as an overlay of a blue dashed line. The resistive bolometer LOSs that will be used in the later analysis are here identified.

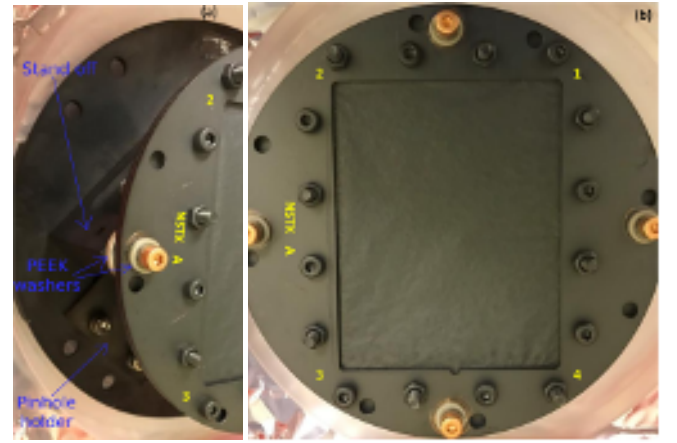

FIG. 9: Photographs of the foil in relation of the pinhole (a) and of all the identifying markings (b), taken 23/07/2018.

IV. SYSTEM CALIBRATION

Before scientific utilization, the IRVB diagnostic has to be properly calibrated. This includes the temperature response of the IR camera, the thermal response of the foil and spatial alignment of the pinhole and camera. Laboratory tests can be performed for the first two calibrations, while the third was verified during operation, using observed features inside the tokamak.

A. Counts to temperature model

The temperature calibration is the procedure used to convert the camera raw data from counts to temperature. It involves defining the mathematical model for the conversion and finding the coefficients required. Once defined it can be applied to MAST-U data to obtain the IRVB foil temperature. The surface of the foil is approximated as a black body emitter. The total number of photons emitted by a BB source Φ_p within the camera integration time can be modelled as per Equation 1

$$\Phi_p(T) = \varepsilon i \int_{\lambda_1}^{\lambda_2} \frac{2\pi c}{\lambda^4} \frac{1}{e^{\frac{hc}{\lambda kT}} - 1} d\lambda \quad (1)$$

where ε is the emissivity, i the integration time, λ the wavelength, $\lambda_1 - \lambda_2$ the wavelength range allowed by the camera or filter and T the surface temperature. To simplify the calculations an interpolator is built such that:

$$\frac{\Phi_p(T)}{T} = \alpha(T), T = \alpha_r(\Phi_p) \quad (2)$$

The number of photons reaching the camera is proportional to the number of photons emitted from the absorber foil (a_1), with an additional offset due to thermal photons originating from the view port and the air between sample and camera as

well as their reflections (a_2). This offset will be approximately constant because it will not depend on the surface temperature observed by the camera. Assuming that the number of counts is proportional to the number of photons, and that this does not depend on the photon wavelength, the number of camera counts can be expressed as:

$$C = a_1 \cdot \Phi_p(T) + a_2 \quad (3)$$

where $a_1 \in [0, \infty]$ and $a_2 \in [-\infty, \infty]$ the proportional and constant components. Once a_1 is determined the temperature is calculated as:

$$T = \alpha_r(\Phi_p(T)) = \alpha_r\left(\frac{C - a_2}{a_1}\right) = \alpha_r\left(\frac{C - C_0}{a_1} + \Phi_p(T_0)\right) \quad (4)$$

T_0 and C_0 are the temperature and counts relative to the initial conditions at the beginning of the shot (approximated with the vacuum vessel temperature). The power absorbed by the IRVB foil is obtained using the temperature increase over the profile before the pulse so the constant offset from the calibration will not impact the results.

B. Temperature calibration

Given that the IRVB relies on measuring small temperature differentials with high precision it was necessary to calibrate all camera pixels independently. Given a black body source that could encompass the entire field of view with the image in focus was not available, the method employed was similar to the one by Reinke⁸: A Sofradir non-uniformity correction (NUC) plate, built such that it emits black body radiation uniformly with an emissivity close to 1, was used. The plate was then heated in an oven to $\sim 70^\circ\text{C}$, then left to cool to room temperature while taking samples with the IR camera. Similarly, the plate was also cooled below room temperature and observed while heating up. The temperature of the plate was monitored with a thermocouple. For consistency, two cooling and heating temperature ramps were performed and the data fitted with the model in Section IV A. The infrared camera is equipped with two distinct digitizers therefore the calibration will be operated independently for each. This means that the two digitizers behave as two distinct instruments; the power absorbed by the foil will be calculated independently for each and then averaged, causing a reduction of the maximum (full frame) frame rate from 383 to 192Hz.

The geometry of the calibration is represented in Figure 10. The relative distances are the same as when the camera is installed. The rotational orientation of the view port was maintained during calibration and on the machine thanks to markings on the side of the window. During testing the narcissus effect was clearly observed.

Figure 11 displays the qualitative effect of the presence of the view port. Figure 11a shows the typical view when the camera images the NUC plate; vignetting due to the camera

lenses is apparent. Figure 11b shows the effect of the window reflections. In Figure 11c the effect on the foil image is shown. The dark spot caused by the narcissus is at the centre of the image, decreasing the counts by ~ 200 counts at an integration time of 2ms . This should be a systematic error and, therefore, should mostly impact the a_2 coefficient that ultimately doesn't impact the temperature measurement. During the temperature ramps it was observed that the NUC plate, albeit having a uniform emissivity, shows a non uniform temperature across the FOV due to heat transfer. The plate is naturally cooled/heated via conduction, convection and black body radiation. Air flows around the plate and can lead to uneven heat transport.

The temperature non uniformity across the image was estimated for different temperature ramps as shown in Figure 12b and it was found to be at most 0.3°C on average in the temperature range of interest. As shown in Figure 12a the spatial variation of temperature is very slow, with a very minor impact on the spatial and temporal derivative. The effect of the location where the thermocouple is connected to the NUC plate was also investigated by moving it to different corners of the plate. The spread of the temperature around a curve that fits average camera counts and temperature for all the probe positions with the model in Section IV A is about 0.25°C . There was, though, no pattern found so the difference is most likely due to the connection of the sensor to the plate rather than the actual temperature of the plate.

The result of the scan for the two pixels identified in Figure 11, one close to the centre of the narcissus effect and one on its side, are shown in Figure 13. Equation 3 can reproduce the measurements with high accuracy. As expected the presence of the narcissus mostly affects the a_2 offset.

The results of the calibration for the entire foil are shown in Figure 14. Both coefficients are affected by vignetting and the narcissus effect. It is noteworthy that the ~ 200 counts at the centre of the narcissus are assigned entirely to the constant parameter, as one would expect for a systematic error. Some of the variation in a_1 , especially the red ring around the centre, could be related to the narcissus, meaning that its effect is not completely independent of temperature. The variation in a_1 is very small, however, only $\sim 2\%$ and changes fairly slowly across the FOV, resulting in a small impact on the spatial and temporal temperature derivatives. Both coefficients seem to have a general dependency on the vertical direction (right to left in the figure), possibly due to the slight non-uniformity of the temperature of the NUC plate.

For future calibrations, a large flat black body calibration source with the capability to cool below and heat above room temperature could be used to further reduce the uncertainties in the NUC plate temperature.

C. Foil model

The foil thermal response is dictated by heat transport: the source is the radiated power from the plasma (P_{foil}) while the local sinks are its black body radiation (P_{BB}), conduction ($P_{\Delta T}$) and temperature variation ($P_{\frac{\partial T}{\partial t}}$). The foil is very thin and

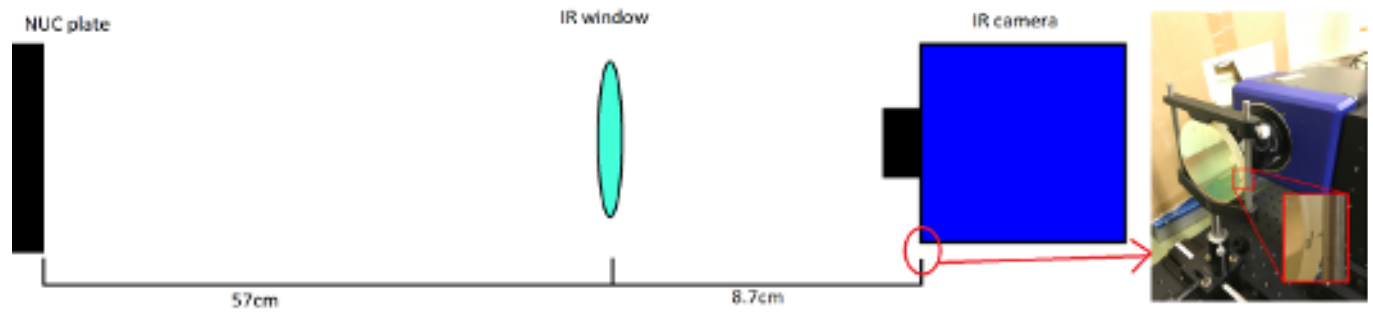

FIG. 10: Schematic of the calibration setup. The NUC plate and the IR window are located at the same distance from the camera as when installed and as per design. Effort is made to keep the window with the same rotational orientation. See the marking for the view port alignment in the detail.

therefore 2D heat transport can safely be considered instead of 3D. Equation 5 shows how to calculate the power absorbed by the foil based on its temperature.

$$\begin{aligned}
 P_{foil} &= P_{\frac{\partial T}{\partial r}} + P_{\Delta T} + P_{BB} \\
 P_{\frac{\partial T}{\partial r}} &= \frac{kt_f}{\kappa} \frac{dT}{dt} \\
 P_{\Delta T} &= -kt_f \left(\frac{\partial^2 T}{\partial x^2} + \frac{\partial^2 T}{\partial y^2} \right) \approx -kt_f L \cdot T \\
 P_{BB} &= 2\epsilon \sigma_{SB} (T^4 - T_0^4)
 \end{aligned} \quad (5)$$

where k is the thermal conductivity, t_f the thickness, κ the thermal diffusivity, ϵ the black body emissivity and σ_{SB} the Stefan-Boltzmann constant. L is the matrix containing the coefficients to build the temperature Laplacian via the dot product. It is built such that its dot product with the temperature returns the sum of the second order central finite difference in all directions. In the Laplacian matrix the elements corresponding to the derivative in the diagonal direction are divided by 2, to account for the increase in distance.

Assuming $\alpha(T)$ to be slowly varying the uncertainty in the temporal variation, diffusion and radiation terms of the heat equation can be calculated with Equations 6, 7 and 8 respectively for the pixel i :

$$\sigma_{\frac{\partial T}{\partial t}} = \frac{kt_f}{\kappa dt} \sqrt{\left(\frac{\sigma_{C_{i+1}}}{a_1 \alpha(T_{i+1})} \right)^2 + \left(\frac{\sigma_{C_{i-1}}}{a_1 \alpha(T_{i-1})} \right)^2 + \left[(T_{i+1} - T_{i-1}) \frac{\sigma_{a_1}}{a_1} \right]^2} \quad (6)$$

$$\sigma_{\Delta T} = \frac{kt_f}{dx^2} \sqrt{L^2 \cdot \left[\left(\frac{\sigma_{C_i}}{a_1 \alpha(T_i)} \right)^2 + \left(\frac{\sigma_{C_0}}{a_1 \alpha(T_0)} \right)^2 + \left((T_i - T_0) \frac{\sigma_{a_1}}{a_1} \right)^2 \right]} \quad (7)$$

$$\sigma_{T_i} = \frac{1}{\alpha(T_i)} \sqrt{\frac{(\sigma_{C_i}^2 + \sigma_{C_0}^2)}{a_1^2} + \left[\left(\frac{C_i - C_0}{a_1} \right) \frac{\sigma_{a_1}}{a_1} \right]^2 + (\alpha(T_i) \sigma_{T_0})^2}$$

$$\sigma_{BB} = 4\epsilon \sigma_{SB} \sqrt{(T_i^3 \sigma_{T_i})^2 + (T_0^3 \sigma_{T_0})^2} \quad (8)$$

D. Foil calibration

In this section the calibration procedure followed to obtain the foil properties will be detailed. To calibrate the foil its thickness t_f , thermal κ diffusivity and black body emissivity ϵ must be determined (assuming nominal Platinum thermal conductivity $k = 71.6W/mK$). A set of spatially resolved parameters was supplied together with the foil of which the average and variability across the foil corresponds to $\epsilon = 0.85 \pm 0.04$, $t_f = 1.29 \pm 0.17 \mu m$. Nominal platinum thermal diffusivity is assumed $\kappa = 2.5 \cdot 10^{-5} m^2/s$. These values were obtained with a single exposure of a laser of known power, pulse and spatial shape by monitoring the cooling down phase of the foil in vacuum as described in²⁸. There are different ways to find the foil parameters, all reliant on shining a laser on the foil (see references^{28,31,32}).

Rather than using a single laser exposure, the method of choice relied upon varying the laser intensity, frequency and focus as done by Reinke.⁸ With slow pulses, the time variation component tends to become irrelevant such that only black body radiation and diffusion remain. With a defocused laser (low laser power density), the temperature increase is low and the spatial distribution slowly varying, increasing the relevance of the black body radiation. With a fast pulsed laser the time dependent component is dominant.

A bench top vacuum system was built for the foil calibration, shown in Figure 15. The vacuum is necessary to eliminate convection as a heat loss mechanism, as it is also absent during the experiments. The pressure during calibration was $\sim 3 \cdot 10^{-5} bar$, compared to $\sim 10^{-8} bar$ during MAST-U experiments. A $5mW$, $655nm$ BlueLyte laser was used, capable of gradually reducing the total power output to zero and with a maximum modulation up to $750kHz$. The laser was equipped with an adjustable lens to change the focus. The laser was calibrated with a Thorlabs PDA100A2 diode in combination with a variable aperture. The maximum laser intensity was measured to be about $1200W/m^2$ and $50W/m^2$ when focused and defocused respectively, with a maximum total power of $4.16mW$. The laser was controlled with a square wave function generator so that the laser output was modulated in intensity, frequency and focus. The transmission of the vacuum

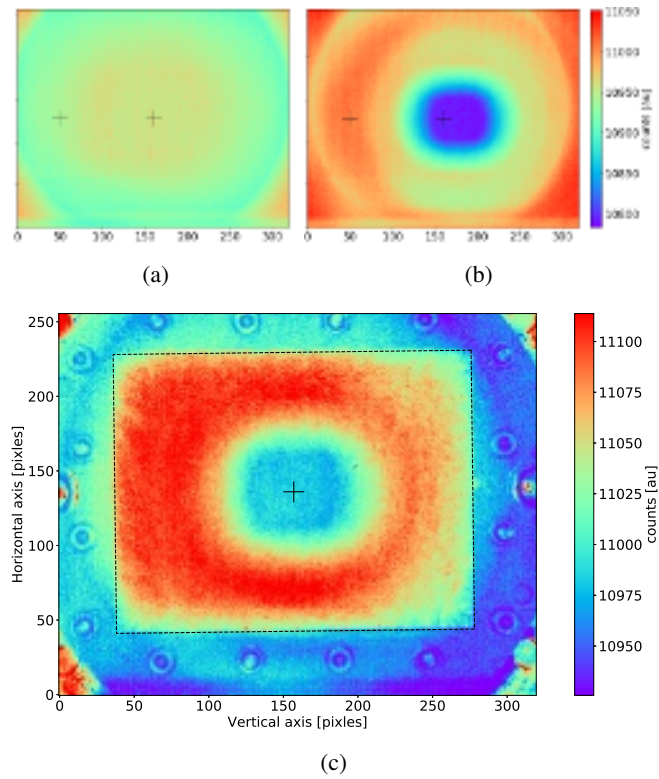

FIG. 11: Example of non uniformity of the counts of the IR camera when aimed at the NUC plate at room temperature. Shown are the images without the view port (a) and with (b). The same scale is applied to both plots and there was a 2ms integration time. The black cross indicates two reference points (inside/outside the narcissus) that will be used in later analysis. c shows the position of the foil (the red square) inside the camera field of view. Around the foil are the bolts that lock the foil in between the two copper plates, that can be used to identify the foil orientation.

window on the laser side was measured at 93.3% and taken into account. The power delivered to the foil integrated over the pinhole area, P , can be determined with Equation 5. To find the foil thermal properties, the running average of P is computed, averaging over the duration of half the square wave duration. The peaks P_h and troughs P_l of the running average are compared to the input values P_m .

A scan in laser power from 0 to 100% and frequency from 0.2 to 90Hz with the laser fully focused and fully defocused was carried out in the location of the foil closer to the pinhole. The fit was done with data up to 10Hz returning the following fit parameters: $\varepsilon = 1$, $t_f = 2.69\mu\text{m}$, $\kappa = 1.35 \cdot 10^{-5} \text{m}^2/\text{s}$. The t_f/κ ratio is similar to foil properties measured prior to the installation on NSTX-U, differing significantly from the supplied one.²⁵ The difference in the t_f and κ values is likely due to the difference in emissivity inferred.

An example of the power calculated in the laser experiments is shown in Figure 16 while Figure 17 shows the quality of the fit for varying power and frequency and for focused and defocused laser light. It can be observed that above 30Hz the

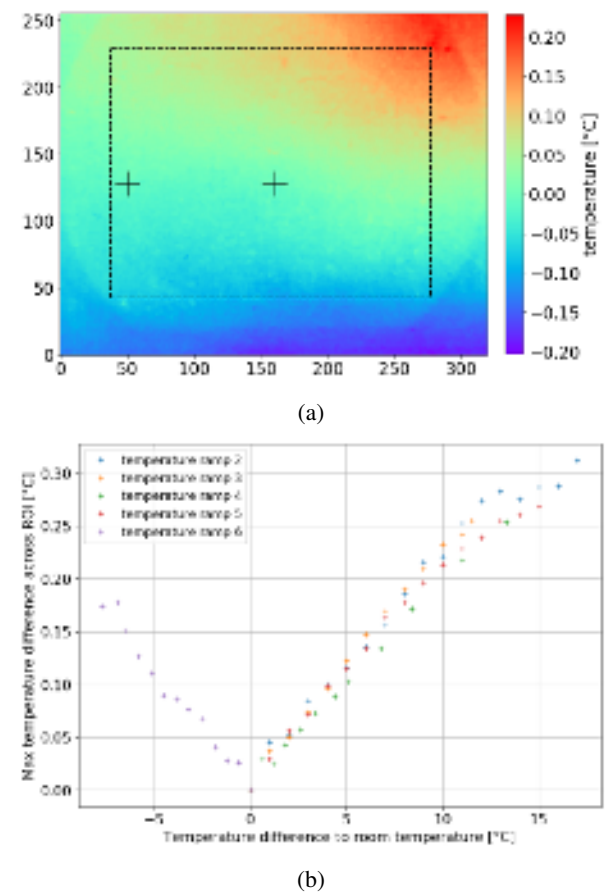

FIG. 12: (a) Shown are the IR camera counts at 41.9°C minus the counts at room temperature, scaled up such that the average across the foil is the same as at high temperature. In black is highlighted the region corresponding approximately to the IRVB foil and the two reference points defined in Figure 11. The vertical orientation is here bottom to top, with the top of the image being up. (b) Peak temperature difference between the temperature deriving from the counts at high temperature and the counts at room temperature scaled up as previously mentioned.

inferred power drops, implying a limit in the temporal resolution of the IRVB. The data corresponding to the defocused laser degrades at lower frequencies, as the total delivered laser power is lower. During these experiments it was also observed that a fixed oscillation of 0.01K at about 29Hz is superimposed on the data so measurements at the same frequency or higher will be affected. The oscillation seems to be independent of the power supply system and the frame rate but proportional to the integration time, ultimately due to the internal operation of the camera.

These foil properties were measured in a single location and were therefore assumed uniform across the foil. To account for the variability across the foil the uncertainty from the fit is increased by the variability of the properties provided to us with the foil. This returns the uncertainties $\sigma_\varepsilon/\varepsilon = 8.61\%$, $\sigma_{t_f}/t_f = 13.6\%$, $\sigma_\kappa/\kappa = 13.9\%$ (for κ is used

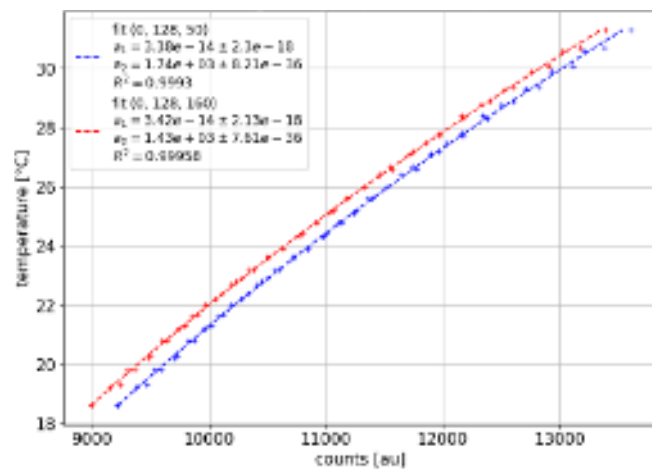

FIG. 13: Comparison of the temperature calibration curves for a pixel at the centre of the narcissus (red) with one on its side (blue). The legend gives the fit parameters (a_1 proportional and a_2 additive components), their uncertainties, and the coefficient of determination of the fit.

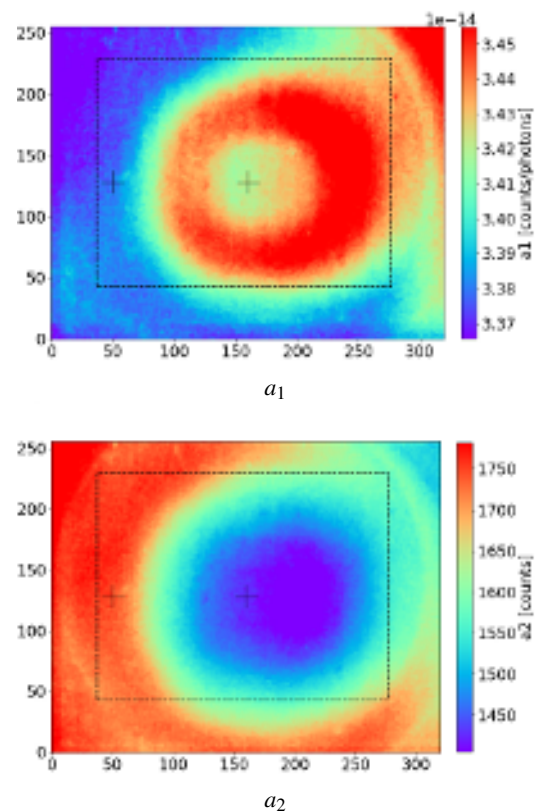

FIG. 14: a_1 and a_2 coefficients of Equation 3 obtained via calibration with the NUC plate. In black is highlighted the region corresponding approximately to the IRVB foil and the two reference points defined in Figure 11. The vertical orientation during this calibration is right to left, with the top on the left.

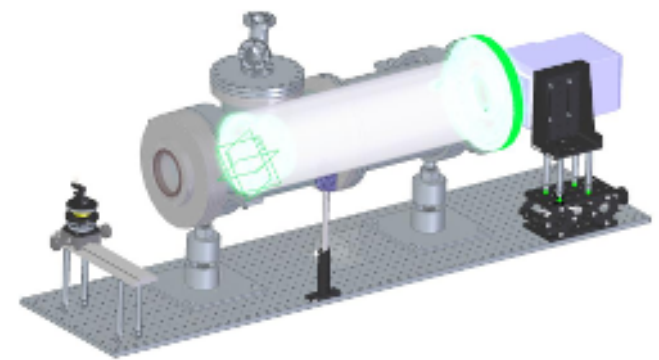
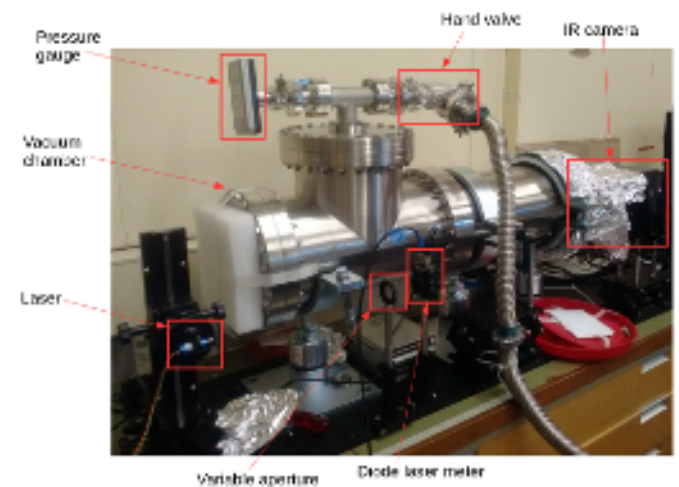

FIG. 15: Photograph (a) and CAD model (b) of the bench-top setup used for the foil calibration. In the CAD model the re-entrant tube is shown in white and the foil assembly is on the left side. The photograph, taken on 02/08/2018, shows the laser used to illuminate the foil, as well as the diode and aperture used to calibrate the laser and vacuum system.

the same variability across the foil as for t_f).

E. Viewing geometry validation

The viewing geometry of the diagnostic as designed in Section III has to be validated to make sure that each IRVB pixel FOV into the plasma is as expected. For diagnostics where a camera is directly imaging inside the vacuum vessel this is usually done by acquiring long exposure images and matching the observed features on the machine surface with features from CAD models. For bolometers this is not possible as the black body radiation of the vessel surfaces is many orders of magnitude below the detection limit, even when heated up by the plasma. For this reason this spatial calibration has to rely on laser light sources. The size and orientation of the LOS viewing cone is often measured in dedicated laboratory experiments and translated into machine coordinates using some

This is the author's peer reviewed, accepted manuscript. However, the online version of record will be different from this version once it has been copyedited and typeset.
PLEASE CITE THIS ARTICLE AS DOI: 10.1063/1.50128768

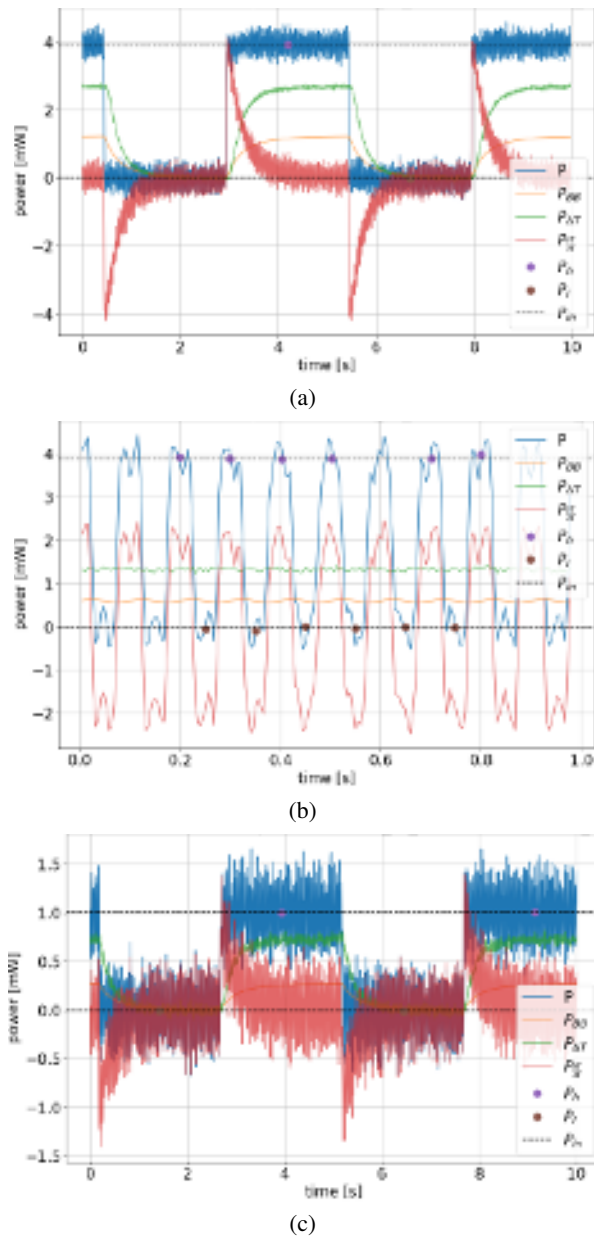

FIG. 16: Examples of the power absorbed by the foil and its components (total absorbed power P and its components black body radiation P_{BB} , conduction $P_{\Delta T}$ and temperature variation $P_{\frac{\partial T}{\partial t}}$; peaks and troughs of P running average, P_h and P_l ; peak input power P_{in}) with the laser at maximum intensity for a focused low frequency case (a), a focused high frequency case (b) and a defocused low frequency one (c).

reference point of the diagnostic assembly and the vessel.^{33,34} If there is good access to the inside of the machine, a laser can be placed in fixed locations to measure the bounds of the light detection region of every LOS.³⁵ More recently, in the effort to develop the bolometer system for ITER, a robotic arm was developed on AUG which can probe the relation between the origin of the emission and sensor response by moving a laser to various positions in the field of view of the bolometer.³⁶

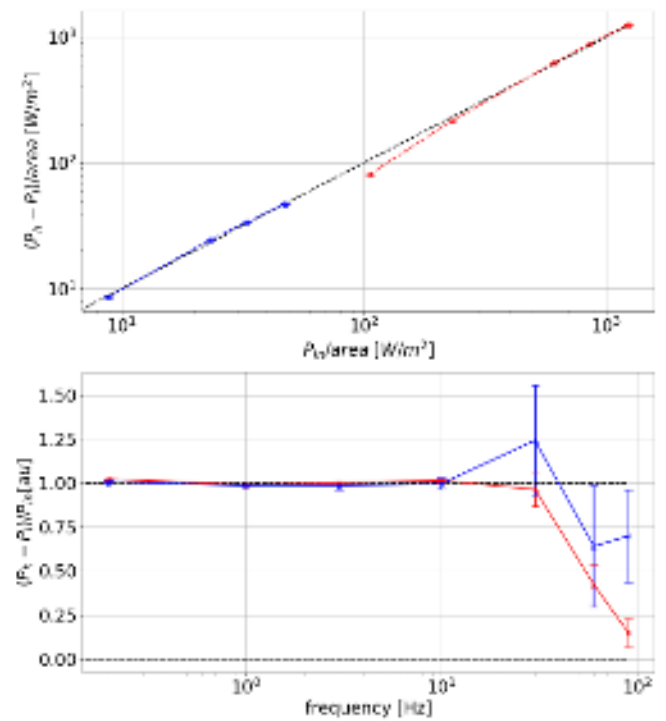

FIG. 17: Variation of the measured power compared to the expected values with laser intensity (top) and frequency (bottom). The blue color indicates the defocused cases while the red the focused ones. P_h and P_l are the inferred high and low power level of the laser square wave, $area$ is the area of the foil receiving laser light, P_{in} is the known peak laser power density.

An inability to access the interior of MAST-U prevented these types of measurements. For these reasons the geometry of the IRVB was verified by comparing known features of the plasma during operation with their expected locations, adapting methods used for visible imaging. The bright features of interest are fueling locations, alignment of the center-column and the flash heating of the foil from disruptions.

1. Spatial calibration using fueling valves and EFIT++

The plasma can be fuelled via a multitude of entry ports, of which only some are directly visible by the IRVB. The names of the valves corresponding to the visible outlets are indicated in Figure 7. If hot plasma is present in the immediate vicinity of the gas outlet, the hot electrons dissociate and then excite and ionise the injected neutrals. If the electron temperature is not too high and the plasma is close enough, a bright non-toroidally-symmetric emission appears in the vicinity of the gas outlet. In all the observed discharges when the gas injection valve PFR_BOT_B01 was employed, a localised bright region never appeared, possibly because the separatrix was too far away or the gas flow too low. The fuelling valves, then, that caused a visible localised emission to appear in the IRVB FOV are HFS_MID_L08 and HFS_BOT_B03, al-

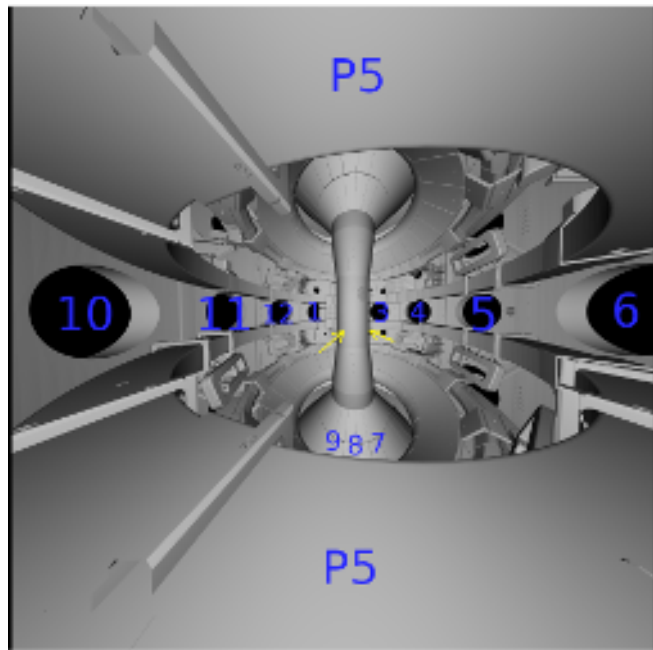

FIG. 18: Field of view of the high speed visible light camera indicating the sector numbers. In yellow the locations of the outlets of the gas valve HFS_MID_L08 are indicated.

though HFS_BOT_B03 was only used once and thus not very useful to compare across pulses.

The 2 HFS_MID_L08 valve outlets locations at the inner wall can be used as one spatial calibration of the IRVB viewing geometry. The valve is consistently used throughout MU01 and its outlets are both in the field of view of the high speed visible light camera (HSV), shown in Figure 18, while only one outlet is in the IRVB FOV. Strong visible light brightness does not necessarily indicate a strong total radiated power, but indicates regions where neutral hydrogen is interacting with the plasma.³⁷

Figure 19 shows the comparison of the localised emission arising from the use of valve HFS_MID_L08 for HSV and IRVB for the shot 45351. Figure 19a shows the brightness from the IRVB while Figure 19b shows the brightness from the HSV. The IRVB shows that the emissivity is clearly non symmetric and localised in the proximity of the outlet. The HSV data is affected by saturation but the bright spot due to both outlets is clearly visible. To further illustrate the validity of the comparison Figure 19b shows the time evolution of the average of the relative brightness around outlets compared to the flow rate of gas programmed for the valve. Both IRVB and HSV measure an increase and decrease of the local emissivity that matches the gas output.

Figure 20 shows a later stage of the discharge when the HFS_MID_L08 valve is off. The image, determined with EFIT++ magnetic reconstruction³⁸, shows that high emissivity regions are present along the inner and outer legs as would be expected in the divertor for a detached target. This consistency is true across all shots providing further indication of the similarity of the real IRVB geometry to the designed one.

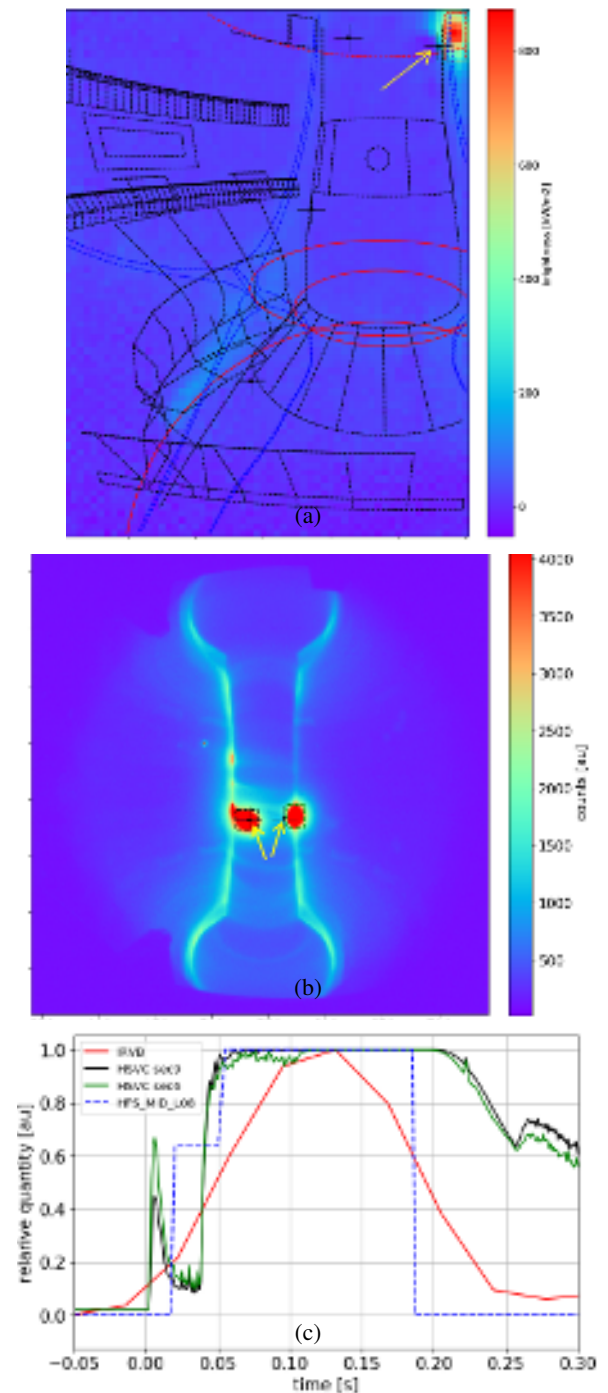

FIG. 19: Example of the radiation caused by the valve HFS_MID_L08 from shot 45295. (a) brightness data from IRVB at 132ms. Shown in dashed blue is the poloidal projection of the separatrix. The toroidal traces of x-point and strike points are shown in solid red, and in dashed red is the magnetic axis. The outlet of the valve HFS_MID_L08 in the IRVB FOV, marked by a black cross and a yellow arrow, is clearly visible in the IRVB image. In (b) a cropped image of the raw data from the high speed visible light camera (HSV) for the same shot at 50ms. The two bright spots correspond to the two outlets from the valve, both in the HSV FOV, marked as in (a). Note: this data is affected by saturation. In (c), the relative average of the readings inside the dashed regions that are outlined in a and b, and the programmed flow for the HFS_MID_L08 valve.

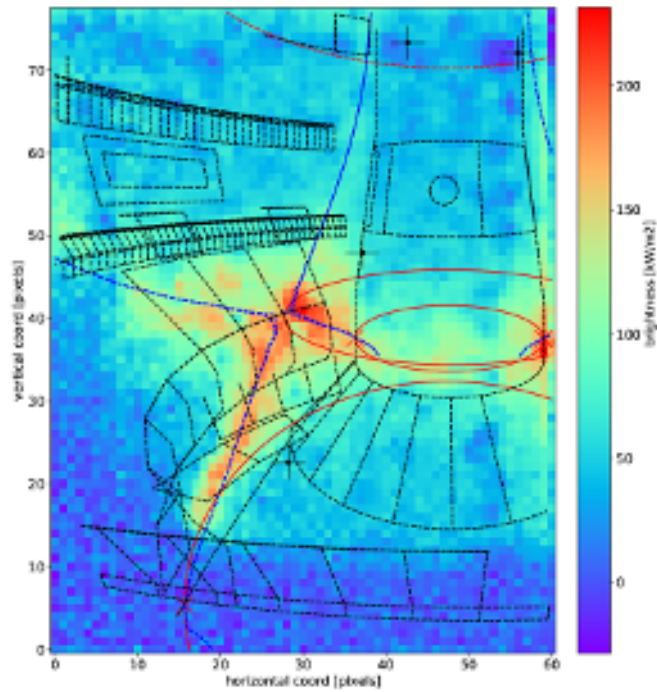

FIG. 20: IRVB Brightness image of the plasma from shot 45295, 388ms, at a time when high field side valves are off and the target is radiatively detached. In blue a tangential projection the separatrix from EFIT++ magnetic reconstruction overlaid on the image using nominal IRVB design geometry. The toroidal traces of x-point and strike points are shown in solid red, and in dashed red, is the magnetic axis.

2. Spatial calibration using disruptions

During disruptions the core plasma can quickly move towards plasma facing components (PFC). There the ion flux is recycled as neutrals which are then excited through electron-atom interactions, leading to a strong localised radiation from the proximity of the PFCs in question. Additionally, some carbon can be sputtered from the PFCs because of the sudden increase of particle flux and also lead to radiation from the excited C ions and neutrals. Because of the transient nature of the phenomena it is sufficient to investigate the temporal derivative of the foil temperature, neglecting the other components of the heat transfer equation, to locate regions where a high emission originates.

Figure 21 shows the foil temperature increase due to a disruption at the end of shot 45225. The plasma moved towards the lower half of the machine and as a consequence a strong emission comes from regions of the image within close proximity to the tiles. Details of the radiation structure can't be easily interpreted as the source of signal is not necessarily toroidally symmetric. A bright emission is present close to the tiles around the baffle and it is therefore possible to observe the presence of a part of the foil that cannot be illuminated because of the interference of the P6 coil close to the pinhole seen in Figure 7. The demarcation line between the region of

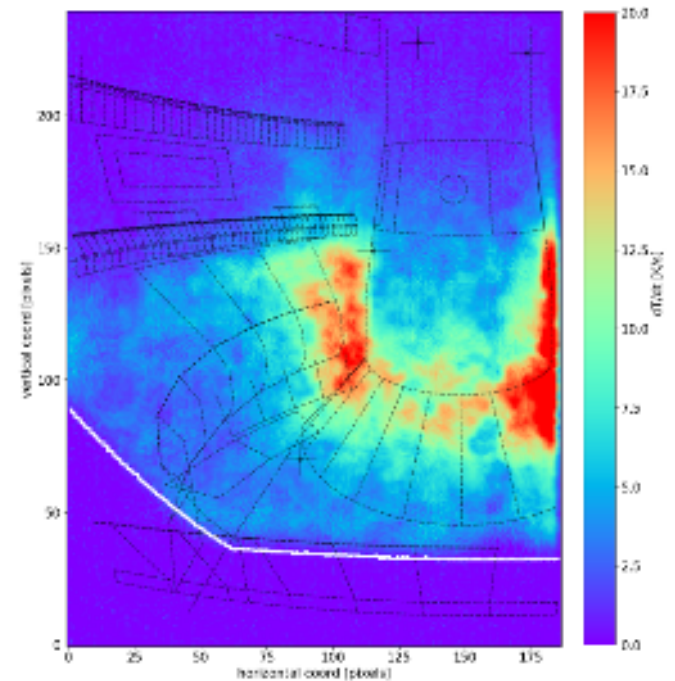

FIG. 21: Image of foil temperature increase due to the disruption of the plasma in shot 45225. No temporal or spatial binning of the data applied. Indicated in white is the demarcation line between the region of the foil that receives any radiation or none from an homogeneous emitter in the core and divertor region from Figure 5.

the foil that can or cannot receive radiation from Figure 5 is overlaid, and it lines up well with the observation.

From the above observations it can be stated that the IRVB is positioned "close" to what is expected from the design; we cannot be quantitative in determining how accurate the view of each pixel is. The FOV calibration could be further improved by including the valve HFS_MID_LO2 and modifying the geometry such that the observation in Figure 5 has an even better match with Figure 21, but a confirmation of the geometry as per design is for now sufficient.

V. RESULTS

Once the IR camera, the foil and the viewing geometry are validated the IRVB can be used to measure the radiation brightness (and emissivity) from the plasma during experiments. The data is first split between the two digitizers and the counts converted to temperature as per Section IV A. As mentioned in Section IV D the camera is affected by a pickup oscillation of the signal at a frequency of about 29Hz , so the temperature is binned in time over one period of such oscillation, returning a temporal resolution of about 30ms . In order to reduce the noise the temperature is also binned spatially over the foil, with a good compromise between resolution and noise being a 3×3 pixel binning, reducing the independent LOS in the plasma from 36700 to about 3900. The binned tempera-

ture is then used to calculate the power absorbed by the foil and the result from the two digitizers averaged. Finally the power is converted to brightness multiplying by $4\pi/\text{etendue}$.

In conventionally diverted discharges³⁹ in which the core density was progressively increased with either fuelling from the midplane or the divertor, it can be observed that the peak brightness is at first close to the targets before moving along the divertor legs to the x-point forming what has been called an x-point radiator configuration (XPR)⁴⁰ or X-point MARFE⁴¹. On further increase of the density, the radiation moves upstream along the inner separatrix to a region around the midplane where a toroidally symmetric MARFE-like structure forms at the high field side (HFS) of the plasma⁴². From there the structure becomes brighter and moves slowly inwards from the inner wall, correlating with the ensuing disruption.

These phases are shown for the double null low power Ohmic shot 45473 in Figure 22. The movement of the radiation can be correlated with other plasma parameters like the core plasma density and with the existing resistive bolometry system for which the chordal views are shown in Figure 8. For MU01, multiple LOSs of the resistive bolometers were damaged and the measurements were severely affected by noise, but the system was robust enough to return low time resolution data. The two LOS closest to the x-point are not available, but the one just below the midplane (CH9, see Figure 8) is.

Figure 23 shows the comparison between resistive bolometry CH9 chordal brightness and similar brightness measurements from the IRVB. Figure 23a shows the average IRVB brightness inside the regions marked with matching colors in Figure 22 vs time. The region with the highest brightness changes with time according to the time development described for Figure 22. This is related to a monotonic increase of the core density that causes the plasma to detach from the targets. The brightness from the resistive bolometer CH9 (Figure 23d) has to be compared with the midplane data from the IRVB (Figure 23a). The absolute value of the brightness is different, with the IRVB recording about two times the brightness of the resistive bolometer (possibly because the LOS of the IRVB is integrated over a much longer path through the plasma). Most importantly, though, the emission starts to rise for both at $\sim 550\text{ms}$ and at a similar rate, indicating that both are observing the same phenomena. An important observation to demonstrate the absence of systematic errors is to check the region of the foil that should not receive radiation from the plasma shown in Figure 5. This is labelled as *control* in Figure 23 and while drifting upwards in time it is much smaller than the relevant quantities. This region can also be used to measure the noise level of the diagnostic. The measured NEPD, with the binning mentioned above, is $0.79\text{W}/\text{m}^2$, close to that indicated by previous models ($0.58\text{W}/\text{m}^2$ from⁴³) and below initial expectations. The uncertainty on the power density with the same binning, whose estimate includes the uncertainty on the foil parameters and the camera calibration, has a minimum of about $10\text{W}/\text{m}^2$, gradually increasing with a stronger signal up to about $30\text{W}/\text{m}^2$ in Figure 24d.

In higher power discharges, like when the NBI is used and H-mode can be achieved, a similar sequence of events hap-

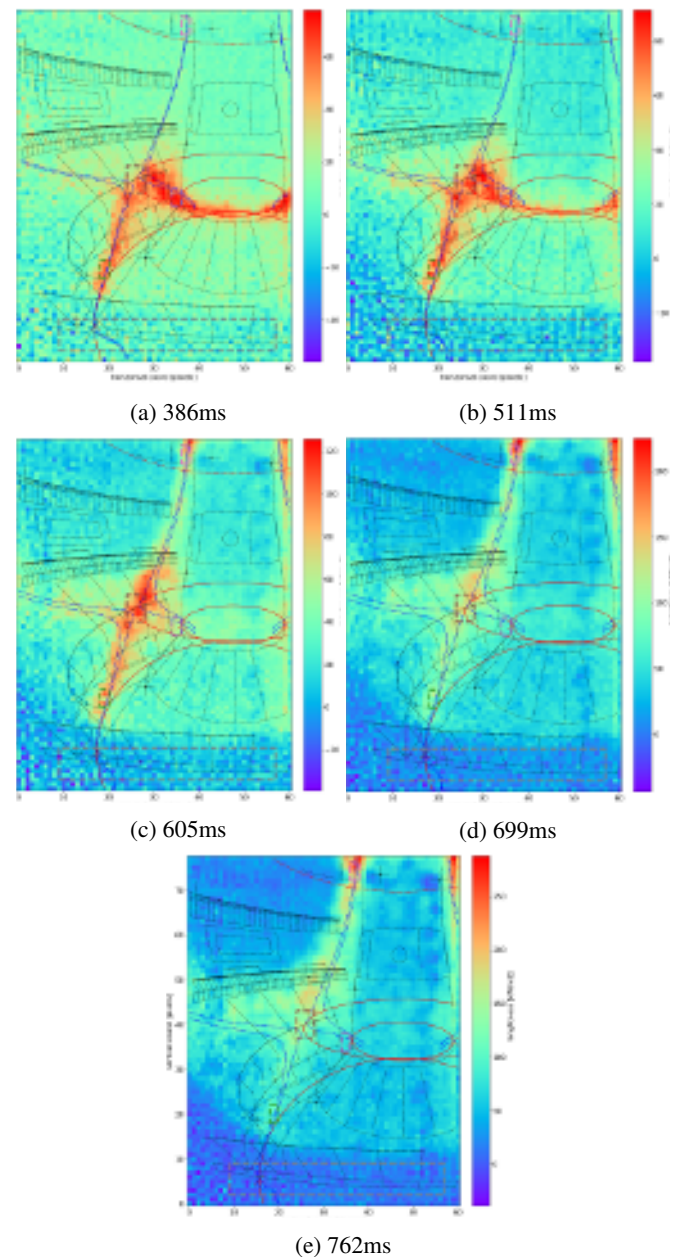

FIG. 22: Changes in brightness pattern in a density ramp for a conventional divertor, L-mode, Ohmic plasma (shot 45473, Double-null and 600kA). First the inner target is radiatively attached (a), then it starts detaching (b) to form an x-point radiator (c) and finally a radiation MARFE-like structure on the high field side (HFS) midplane (d). Further increasing the density the structure moves inward (e) leading to a disruption. Note that the all images have different color bar ranges. The average brightness in the regions marked by the dashed lines (green: outer target, violet: inner target, brown: x-point, pink: midplane, gray: control) will be used for later analysis.

This is the author's peer reviewed, accepted manuscript. However, the online version of record will be different from this version once it has been copyedited and typeset.
PLEASE CITE THIS ARTICLE AS DOI: 10.1063/1.50128768

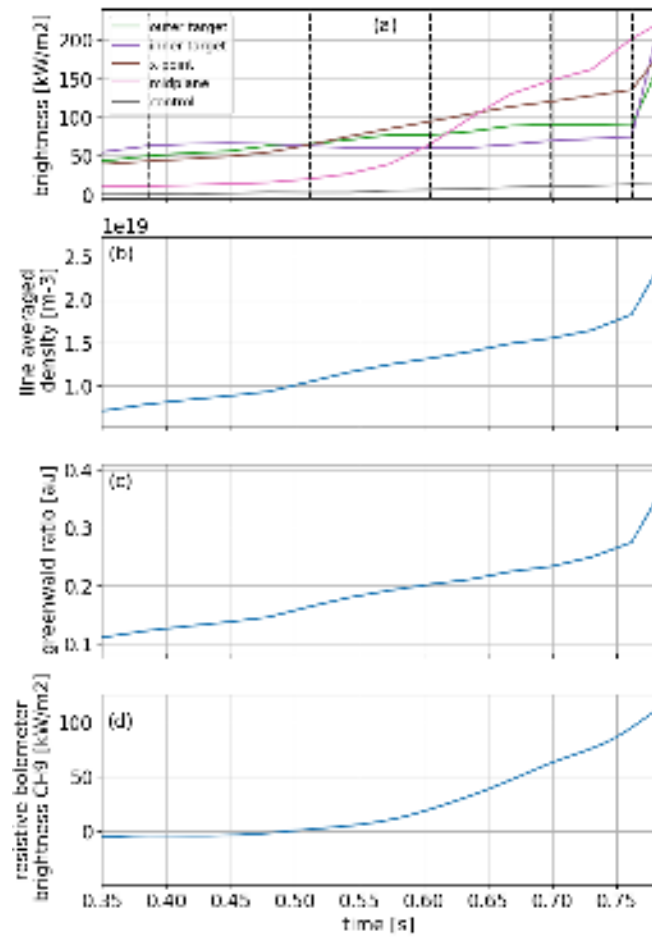

FIG. 23: Comparison of the measurements from different diagnostics for the shot 45473. In (a) is the IRVB brightness averaged inside the regions indicated with dashed lines of matching colors around the x-point and other regions in Figure 22 while the vertical black lines indicate the time corresponding to the images in Figure 22. In (b) is the core line averaged density, (c) is the Greenwald density ratio and (d) is the brightness from the resistive bolometer core toroidal channel 9.

pens to that shown and discussed above for L-mode plasmas and detachment. This is demonstrated in Figure 24 which shows the change in IRVB brightness pattern for a conventional divertor beam heated discharge. The sequence proceeds as for the lower power one, except that after the HFS MARFE-like structure is developed, the core density decreases and the peak radiation moves back closer to the x-point. The brightness is much higher than Figure 22 because of the increase in heating power. In Figure 24a a region at the top left of the image that shows strong brightness but which does not seem field aligned can be observed. This region typically has strong brightness in beam heated discharges before and after the H-mode phase. Similar behaviour was observed also in resistive bolometry for LOS aimed in the direction opposite to the NBI. The origin of this effect is unclear but it is possible

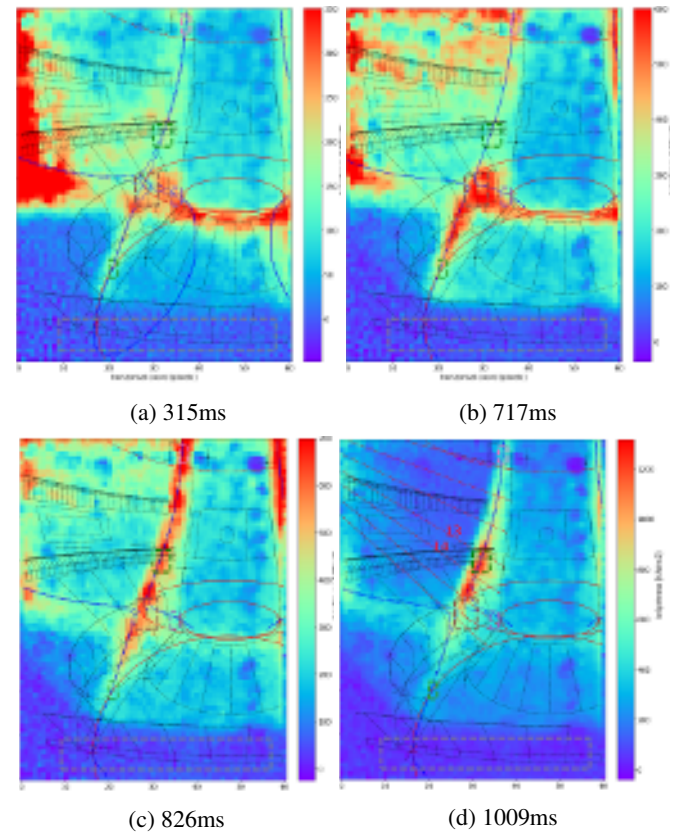

FIG. 24: Changes in brightness pattern in a density ramp for a conventional divertor, H-mode, beam heated plasma (shot 45401, Double-null and 750kA). First, the inner target is radiatively attached (a). Then, it detaches and forms an x-point radiator (b) and finally a radiation MARFE-like structure on the HFS midplane (c). In this shot the density was decreased after this point and this resulted in the peak radiation to move back towards the x-point (d). The bright region at the top left of (a) is likely due to the foil being heated by a particle flux rather than radiation from the plasma. In (d) are overlaid in dashed red and numbered, the resistive bolometer LOS through similar regions as included in the IRVB brightness image shown. Note that all images have different color bar ranges. The average brightness in the regions marked by the dashed lines (green: outer target, violet: inner target, brown: x-point, pink: midplane, gray: control) will be used for later analysis.

that the heat flux is associated with fast particles escaping the core plasma and undergoing charge exchange. This could be verified by comparing the brightness of the region of interest with data from the fast ion loss detector diagnostic, or results from modelling, but it is outside the scope of this manuscript.

Figure 25 shows the relevant time traces for shot 45401. The density is much higher and the Greenwald fraction (a metric of the tokamak performance such that the maximum usually achievable is 1⁴⁴) corresponding to radiative detachment is around 0.6 rather than 0.15 as for the lower power shot 45473. Here the comparison with resistive bolometry can be

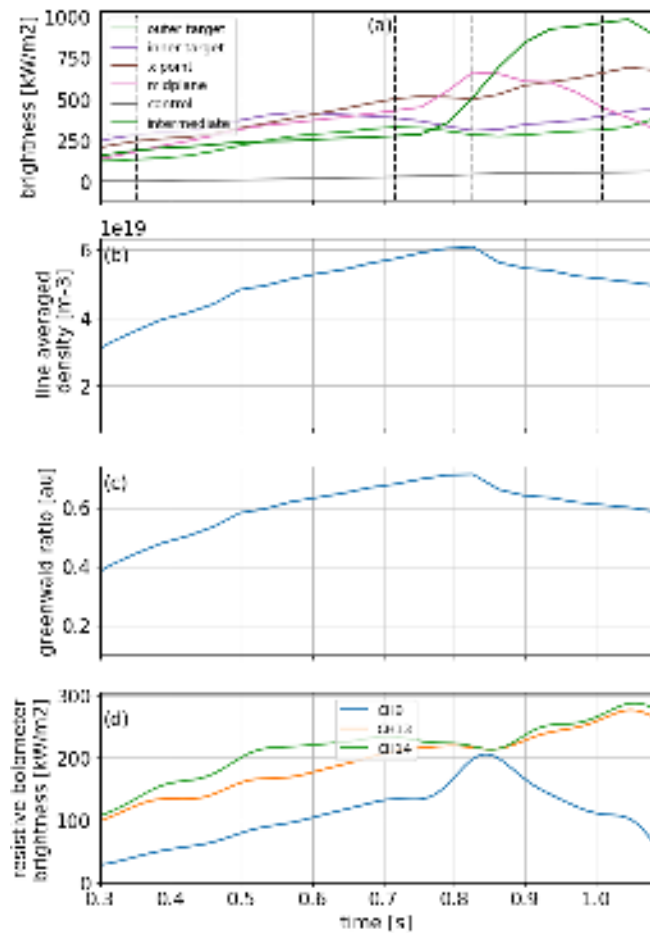

FIG. 25: Comparison of the measurements from different diagnostics for the shot 45401. In (a) is the IRVB brightness averaged inside the regions indicated with dashed lines in Figure 24 while the black lines indicate the time corresponding to the images in Figure 24. In (b) is the core line averaged density, (c) is the Greenwald density ratio and (d) is the brightness from the resistive bolometer core toroidal channel 9, 13 and 14, where the first corresponds to the midplane while the others to the intermediate regions of the IRVB.

done both at the midplane (CH9) as well as close to the location on the separatrix labelled as intermediate, that corresponds to channel 13 and 14 (CH13, CH14). Agreement is good at the midplane but not as good in the intermediate position, where CH13 and CH14 detect significant radiation even before ~ 850 ms, unlike IRVB. The difference is likely not due to the NBI, as only the leftmost part of the foil is affected, and also only the outermost counter-NBI resistive bolometer LOS is affected (see Figure 8b), while it could be due to a different length of the resistive bolometer LOS in the emitting region or because it is detecting some radiation from the inner leg (CH14 could be more affected than CH13, hence the higher brightness in CH14).

VI. SUMMARY

The IRVB diagnostic was successfully deployed in MAST-U. This represents a new implementation of the bolometric diagnostic, not only because it is the first use on a spherical tokamak device, but also because it is aimed at measuring the total radiation emissivity in the region of the x-point, where significant spatial gradients are expected and a high spatial resolution is necessary. The choices that guided the design of all aspects of the diagnostic are reported, with lessons learned for future implementations. The calibration procedures are detailed, including the verification that the IRVB positioning, viewing geometry and FOV qualitatively match the design after installation, normally a challenging task for bolometers. The early results from the first MAST-U experimental campaign show that the evolution of detachment in a spherical tokamak follows similar trends as for low aspect ratio ones, at least for the conventional divertor. In the first MAST-U campaign (MU01) discharges, with only intrinsic impurities, the radiation peaks move along the two divertor legs and the HFS separatrix depending on the level of detachment. The x-point radiator was observed as an intermediate stage, before the peak of the radiation moves upstream along the inner separatrix up to the HFS midplane forming a toroidally symmetric MARFE-like structure. It was also verified that the IRVB measurements are roughly consistent with resistive bolometry. To further exploit the diagnostic it will be necessary to perform tomographic inversions of the line integrated data to observe the evolution of the poloidal emissivity profile with changes in the core plasma density. This will allow the inner and outer leg to be examined in more detail and demonstrate the expected high spatial resolution from the IRVB. Simplified integral methods exist to extract an approximate total radiated power without the need of a full tomographic inversion⁴⁵ but are here out of scope. Tomographically inverted data and inferences from it will be presented in a future publication dedicated to the scientific exploitation of the diagnostic.

ACKNOWLEDGMENTS

This work is supported by US Department of Energy awards DE-AC05-00OR22725 and DESC0014264 and under the auspices of the Engineering and Physical Sciences Research Council [EP/L01663X/1 and EP/W006839/1]. To obtain further information on the data and models underlying this paper please contact PublicationsManager@ukaea.uk.

Support for M. L. Reinke's contributions was in part provided by Commonwealth Fusion Systems.

This work has been carried out within the framework of the EUROfusion Consortium, funded by the European Union via the Euratom Research and Training Programme (Grant Agreement No 101052200-EUROfusion). Views and opinions expressed are, however, those of the author(s) only and do not necessarily reflect those of the European Union or the European Commission. Neither the European Union nor the European Commission can be held responsible for them.

The authors wish to also acknowledge Byron J. Peterson for

providing the blackened and calibrated platinum foil used as absorber in the IRVB.

- ¹M. Faitsch, T. Eich, G. F. Harrer, E. Wolfrum, D. Brida, P. David, M. Griener, and U. Stroth, "Broadening of the power fall-off length in a high density, high confinement H-mode regime in ASDEX Upgrade," *Nuclear Materials and Energy*, vol. 26, 2021. 1
- ²D. Silvagni, T. Eich, M. Faitsch, T. Happel, B. Sieglin, P. David, D. Nille, L. Gil, and U. Stroth, "Scrape-off layer (SOL) power width scaling and correlation between SOL and pedestal gradients across L, i and H-mode plasmas at ASDEX Upgrade," *Plasma Physics and Controlled Fusion*, vol. 62, no. 4, 2020. 1
- ³A. Q. Kuang, S. Ballinger, D. Brunner, J. Canik, A. J. Creely, T. Gray, M. Greenwald, J. W. Hughes, J. Irby, B. LaBombard, B. Lipschultz, J. D. Lore, M. L. Reinke, J. L. Terry, M. V. Umansky, D. G. Whyte, and S. Wukitch, "Divertor heat flux challenge and mitigation in SPARC," *Journal of Plasma Physics*, 2020. 1
- ⁴A. Loarte, B. Lipschultz, A. S. Kukushkin, G. F. Matthews, P. C. Stangeby, N. Asakura, G. F. Counsell, G. Federici, A. Kallenbach, K. Krieger, A. Mahdavi, V. Philipps, D. Reiter, J. Roth, J. Strachan, D. G. Whyte, R. Doerner, T. Eich, W. Fundamenski, A. Herrmann, M. Fenstermacher, P. Ghendrih, M. Groth, A. Kirschner, S. Konoshima, B. LaBombard, P. Lang, A. W. Leonard, P. Monier-Garbet, R. Neu, H. Pacher, B. Pegourie, R. A. Pitts, S. Takamura, J. L. Terry, and E. Tsitrone, "Chapter 4: Power and particle control," *Nuclear Fusion*, vol. 47, no. 6, 2007. 1
- ⁵A. S. Kukushkin, H. D. Pacher, G. W. Pacher, V. Kotov, R. A. Pitts, and D. Reiter, "Consequences of a reduction of the upstream power SOL width in ITER," *Journal of Nuclear Materials*, vol. 438, no. SUPPL, pp. S203–S207, 2013. [Online]. Available: <http://dx.doi.org/10.1016/j.jnucmat.2013.01.027> 1
- ⁶B. Lipschultz, J. L. Terry, C. Boswell, J. A. Goetz, A. E. Hubbard, S. I. Krashennikov, B. LaBombard, D. A. Pappas, C. S. Pitcher, F. Wising, and S. Wukitch, "The role of particle sinks and sources in Alcator C-Mod detached divertor discharges," *Physics of Plasmas*, vol. 6, no. 5 I, pp. 1907–1916, 1999. 1
- ⁷F. Reimold, M. Wischmeier, M. Bernert, S. Potzel, A. Kallenbach, H. W. Müller, B. Sieglin, and U. Stroth, "Divertor studies in nitrogen induced completely detached H-modes in full tungsten ASDEX Upgrade," *Nuclear Fusion*, vol. 55, no. 3, 2015. 1
- ⁸M. L. Reinke, J. L. Terry, G. G. Van Eden, B. J. Peterson, K. Mukai, T. K. Gray, and B. C. Stratton, "Experimental tests of an infrared video bolometer on Alcator C-Mod," *Review of Scientific Instruments*, vol. 89, no. 10, pp. 1–7, 2018. 1, 3, 7, 8
- ⁹J. M. Gao, Y. Liu, W. Li, J. Lu, Y. B. Dong, Z. W. Xia, P. Yi, and Q. W. Yang, "Minimum Fisher regularization of image reconstruction for infrared imaging bolometer on HL-2A," *Review of Scientific Instruments*, vol. 84, no. 9, 2013. 1
- ¹⁰B. J. Peterson, S. Konoshima, H. Parchamy, M. Kaneko, T. Otori, D. C. Seo, N. Ashikawa, and A. Sukegawa, "Observation of divertor and core radiation in JT-60U by means of bolometric imaging," *Journal of Nuclear Materials*, vol. 363-365, no. 1-3, pp. 412–415, 2007. 1
- ¹¹J. Jang, W. Choe, B. J. Peterson, D. C. Seo, K. Mukai, R. Sano, S. Oh, S. H. Hong, J. Hong, and H. Y. Lee, "Tomographic reconstruction of two-dimensional radiated power distribution during impurity injection in KSTAR plasmas using an infrared imaging video bolometer," *Current Applied Physics*, vol. 18, no. 4, pp. 461–468, 2018. 1
- ¹²B. J. Peterson, S. Oh, D. Seo, J. Jang, J. S. Park, K. Mukai, and W. Choe, "Signal to noise ratio of upgraded imaging bolometer for KSTAR," *Review of Scientific Instruments*, vol. 89, no. 10, 2018. [Online]. Available: <http://dx.doi.org/10.1063/1.5038935> 1
- ¹³B. J. Peterson, "Infrared imaging video bolometer," *Review of Scientific Instruments*, vol. 71, no. 10, pp. 3696–3701, 2000. 1
- ¹⁴B. J. Peterson, E. A. Drapiko, D. Seo, and N. Ashikawa, "Upgrade of Imaging Bolometers on LHD," *Plasma and Fusion Research*, vol. 5, pp. S2095–S2095, 2010. [Online]. Available: <http://joi.jlc.jst.go.jp/JST.JSTAGE/pfr/5.S2095?from=CrossRef> 1, 3
- ¹⁵A. Miyashita, K. Mukai, S. Ohshima, R. Matoike, B. J. Peterson, S. Kobayashi, H. Okada, S. Kado, T. Minami, T. Mizuuchi, S. Konoshima, and K. Nagasaki, "First Application of an InfraRed Imaging Video Bolometer to Heliotron J Plasma," *Plasma and Fusion Research*, vol. 16, pp. 1202079–1, 2021. 1
- ¹⁶K. F. Mast, J. C. Vallet, C. Andelfinger, P. Betzler, H. Kraus, and G. Schramm, "A low noise highly integrated bolometer array for absolute measurement of VUV and soft x radiation," *Review of Scientific Instruments*, vol. 62, no. 3, pp. 744–750, 1991. 1
- ¹⁷S. N. Pandya, B. J. Peterson, R. Sano, K. Mukai, E. A. Drapiko, A. G. Alekseyev, T. Akiyama, M. Itomi, and T. Watanabe, "Calibration of a thin metal foil for infrared imaging video bolometer to estimate the spatial variation of thermal diffusivity using a photo-thermal technique," *Review of Scientific Instruments*, vol. 85, no. 5, 2014. 2, 3
- ¹⁸K. Mukai, B. J. Peterson, N. Ezumi, N. Shigematsu, S. Ohshima, A. Miyashita, and R. Matoike, "Sensitivity improvement of infrared imaging video bolometer for divertor plasma measurement," *Review of Scientific Instruments*, vol. 92, no. 6, 2021. 2
- ¹⁹B. L. Henke, E. M. Gullikson, and J. C. Davis, "X-Ray Interactions: Photoabsorption, Scattering, Transmission, and Reflection at E = 50–30,000 eV, Z = 1–92," *Atomic Data and Nuclear Data Tables*, vol. 54, no. 2, pp. 181–342, 1993. [Online]. Available: https://henke.lbl.gov/optical_constants/https://linkinghub.elsevier.com/retrieve/pii/S0092640X83710132 2, 3
- ²⁰K. Mukai, B. J. Peterson, S. Takayama, and R. Sano, "In situ calibration of the foil detector for an infrared imaging video bolometer using a carbon evaporation technique," *REVIEW OF SCIENTIFIC INSTRUMENTS*, vol. 87, pp. 2014–2017, 2016. 2, 3
- ²¹G. G. Van Eden, M. L. Reinke, B. J. Peterson, T. K. Gray, L. F. Delgado-Aparicio, M. A. Jaworski, J. Lore, K. Mukai, R. Sano, S. N. Pandya, and T. W. Morgan, "Design and characterization of a prototype divertor viewing infrared video bolometer for NSTX-U," *Review of Scientific Instruments*, vol. 87, no. 11, 2016. [Online]. Available: <http://dx.doi.org/10.1063/1.4955487> 2
- ²²C. Giroud, A. Meakins, M. Carr, A. Baciero, and C. Bertrand, "CHERAB spectroscopy modelling framework," 2018. [Online]. Available: <http://doi.org/10.5281/zenodo.1206142> 3
- ²³M. Carr, A. Meakins, A. Baciero, M. Bernert, A. Callarelli, A. Field, C. Giroud, J. Harrison, N. Hawkes, S. Henderson, B. Lipschultz, T. Lunt, D. Moulton, and F. Reimold, "Towards integrated data analysis of divertor diagnostics with ray-tracing," in *44th EPS Conference on Plasma Physics*, no. June 2017, 2017, p. 2017.
- ²⁴A. Meakins, Carr M., "Raysect Python raytracing package," 2017. [Online]. Available: <http://doi.org/10.5281/zenodo.1205064> 3
- ²⁵M. L. Reinke, "Experimental Tests of an Infrared Video Bolometer on Alcator C-Mod," in *22nd Topical Conference on High Temperature Plasma Diagnostics*. San Diego, USA: Oak Ridge National Laboratory, 2018. 3, 9
- ²⁶F. Federici, J. Harrison, T. Farley, and A. J. Thornton, "Analysis routines for the paper "Design and Implementation of a prototype infrared video bolometer (IRVB) in MAST Upgrade"," Culham, UK, 2022. [Online]. Available: <http://zenodo.org/record/7108499> 3
- ²⁷J. F. Rivero-Rodriguez, M. Garcia-Munoz, L. Sanchis, R. Martin, K. G. McClements, R. J. Akers, A. Snicker, J. Ayllon-Guerola, J. Buchanan, P. Cano-Megias, J. Galdon-Quiroga, D. Garcia-Vallejo, and J. Gonzalez-Martin, "Development and installation of a scintillator based detector for fast-ion losses in the MAST-U tokamak," in *45th EPS Conference on Plasma Physics, EPS 2018*, vol. 2018-July, 2018, pp. 233–236. 6
- ²⁸M. Itomi, B. J. Peterson, Y. Yamauchi, R. Sano, K. Mukai, and S. N. Pandya, "Improvement on infrared imaging video bolometer by laser calibration method," *Plasma and Fusion Research*, vol. 9, no. SpecialIssue2, pp. 1–4, 2014. 3, 8
- ²⁹G. G. Van Eden, M. L. Reinke, S. Brons, G. van der Bijl, B. J. Krijger, R. Lavrijsen, S. Huber, R. Perillo, M. van de Sanden, and T. W. Morgan, "Plasma radiation studies in Magnum-PSI using resistive bolometry," *Nuclear Fusion*, vol. 58, no. 10, p. 106006, 2018. [Online]. Available: <http://stacks.iop.org/0029-5515/58/i=10/a=106006?key=crossref.f30310d2b1f793c0cf0d3eeab3463023> 3
- ³⁰E. Havlíčková, J. Harrison, B. Lipschultz, G. Fishpool, A. Kirk, A. J. Thornton, M. Wischmeier, S. Elmore, and S. Allan, "SOLPS analysis of the MAST-U divertor with the effect of heating power and pumping on the access to detachment in the Super-x configuration," *Plasma Physics and Controlled Fusion*, vol. 57, no. 11, 2015. 3

This is the author's peer reviewed, accepted manuscript. However, the online version of record will be different from this version once it has been copyedited and typeset. PLEASE CITE THIS ARTICLE AS DOI: 10.1063/5.0128768

This is the author's peer reviewed, accepted manuscript. However, the online version of record will be different from this version once it has been copyedited and typeset.
PLEASE CITE THIS ARTICLE AS DOI: 10.1063/1.50128768

- ³¹R. Sano, B. J. Peterson, E. A. Drapiko, D. Seo, Y. Yamauchi, and T. Hino, "Foil calibration for IR imaging bolometer by laser irradiation," *Plasma and Fusion Research*, vol. 7, no. SPL.ISS.1, pp. 3–6, 2012. 8
- ³²F. Cernuschi, A. Russo, L. Lorenzoni, and A. Figari, "In-plane thermal diffusivity evaluation by infrared thermography," *Review of Scientific Instruments*, vol. 72, no. 10, pp. 3988–3995, 2001. 8
- ³³K. McCormick, A. Huber, L. C. Ingesson, F. Mast, J. Fink, W. Zeidner, A. Guigon, and S. Sanders, "New bolometry cameras for the JET Enhanced Performance Phase," *Fusion Engineering and Design*, vol. 74, no. 1–4, pp. 679–683, 2005. 11
- ³⁴A. Huber, K. McCormick, P. Andrew, P. Beaumont, S. Dalley, J. Fink, J. C. Fuchs, K. Fullard, W. Fundamenski, L. C. Ingesson, F. Mast, S. Jachmich, G. F. Matthews, P. Mertens, V. Philipps, R. A. Pitts, S. Sanders, and W. Zeidner, "Upgraded bolometer system on JET for improved radiation measurements," *Fusion Engineering and Design*, vol. 82, no. 5–14, pp. 1327–1334, 2007. 11
- ³⁵M. L. Reinke, "Experimental Tests of Parallel Impurity Transport Theory in Tokamak Plasmas," Ph.D. dissertation, Massachusetts Institute of Technology, 2011. [Online]. Available: http://www.psf.mit.edu/library/catalog/reports/2010/11rr/11rr014/11rr014_abs.html 11
- ³⁶F. Penzel, H. Meister, M. Bernert, T. Sehmer, T. Trautmann, M. Kannamüller, J. Koll, and A. W. Koch, "Automated in situ line of sight calibration of ASDEX Upgrade bolometers," *Fusion Engineering and Design*, vol. 89, no. 9–10, pp. 2262–2267, 2014. 11
- ³⁷N. R. Walkden, J. Harrison, S. A. Silburn, T. Farley, S. S. Henderson, A. Kirk, F. Militello, and A. J. Thornton, "Quiescence near the X-point of MAST measured by high speed visible imaging," *Nuclear Fusion*, vol. 57, no. 12, 2017. 12
- ³⁸L. L. Lao, H. S. John, R. D. Stambaugh, A. G. Kellman, and W. Pfeiffer, "Reconstruction of current profile parameters and plasma shapes in tokamaks," *Nuclear Fusion*, vol. 25, no. 11, pp. 1611–1622, 1985. 12
- ³⁹W. Morris, J. R. Harrison, A. Kirk, B. Lipschultz, F. Militello, D. Moulton, and N. R. Walkden, "MAST Upgrade Divertor Facility: A Test Bed for Novel Divertor Solutions," *IEEE Transactions on Plasma Science*, vol. 46, no. 5, pp. 1217–1226, 2018. 14
- ⁴⁰M. Bernert, F. Janky, B. Sieglin, A. Kallenbach, B. Lipschultz, F. Reimold, M. Wischmeier, M. Cavedon, P. David, M. G. Dunne, M. Griener, O. Kudlacek, R. M. McDermott, W. Treutterer, E. Wolfrum, D. Brida, O. Février, S. Henderson, and M. Komm, "X-point radiation, its control and an ELM suppressed radiating regime at the ASDEX Upgrade tokamak," *Nuclear Fusion*, vol. 61, no. 2, 2021. 14
- ⁴¹A. Kallenbach, M. Bernert, M. Beurskens, L. Casali, M. G. Dunne, T. Eich, L. Giannone, A. Herrmann, M. Maraschek, S. Potzel, F. Reimold, V. Rohde, J. Schweinzer, E. Viezzer, and M. Wischmeier, "Partial detachment of high power discharges in ASDEX Upgrade," *Nuclear Fusion*, vol. 55, no. 5, 2015. 14
- ⁴²V. P. Lipschultz, R. La Bombard, P. Marmar, R. Pickrell, R. R. Terry, R. R. Watterson, and S. M. Wolfe, "Marfe: An edge plasma phenomenon," *Nuclear Fusion*, vol. 24, no. 8, pp. 977–988, 1984. 14
- ⁴³S. N. Pandya, B. J. Peterson, M. Kobayashi, S. P. Pandya, K. Mukai, and R. Sano, "A reconsideration of the noise equivalent power and the data analysis procedure for the infrared imaging video bolometers," *Review of Scientific Instruments*, vol. 85, no. 12, 2014. 14
- ⁴⁴M. Greenwald, "Density limits in toroidal plasmas," *Plasma Physics and Controlled Fusion*, vol. 44, no. 8, 2002. 15
- ⁴⁵L. C. Ingesson, "Comparison of Methods to Determine the Total Radiated Power in JET," JET Joint Undertaking, Abingdon, Tech. Rep. 99, 2000. 16

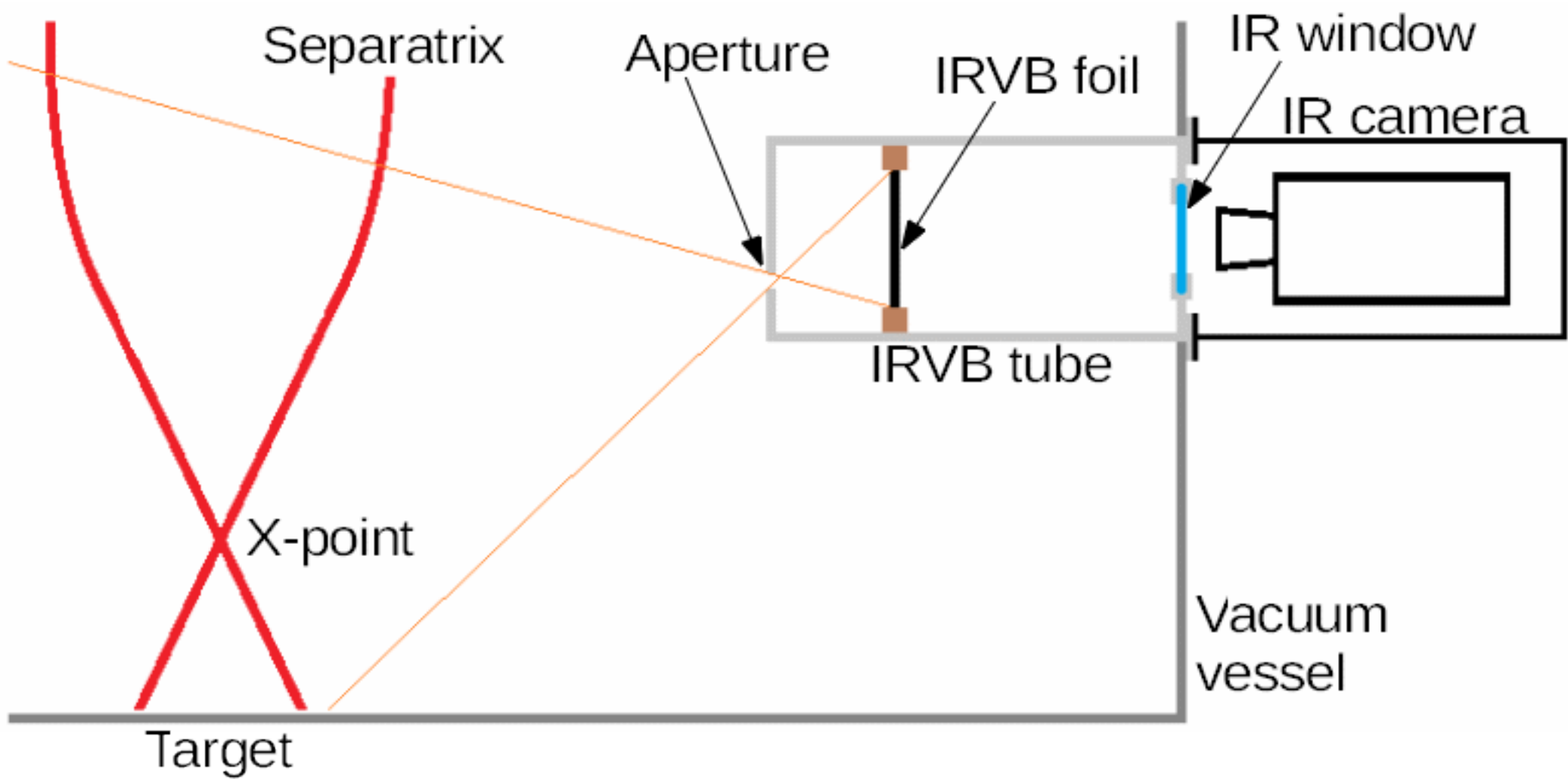

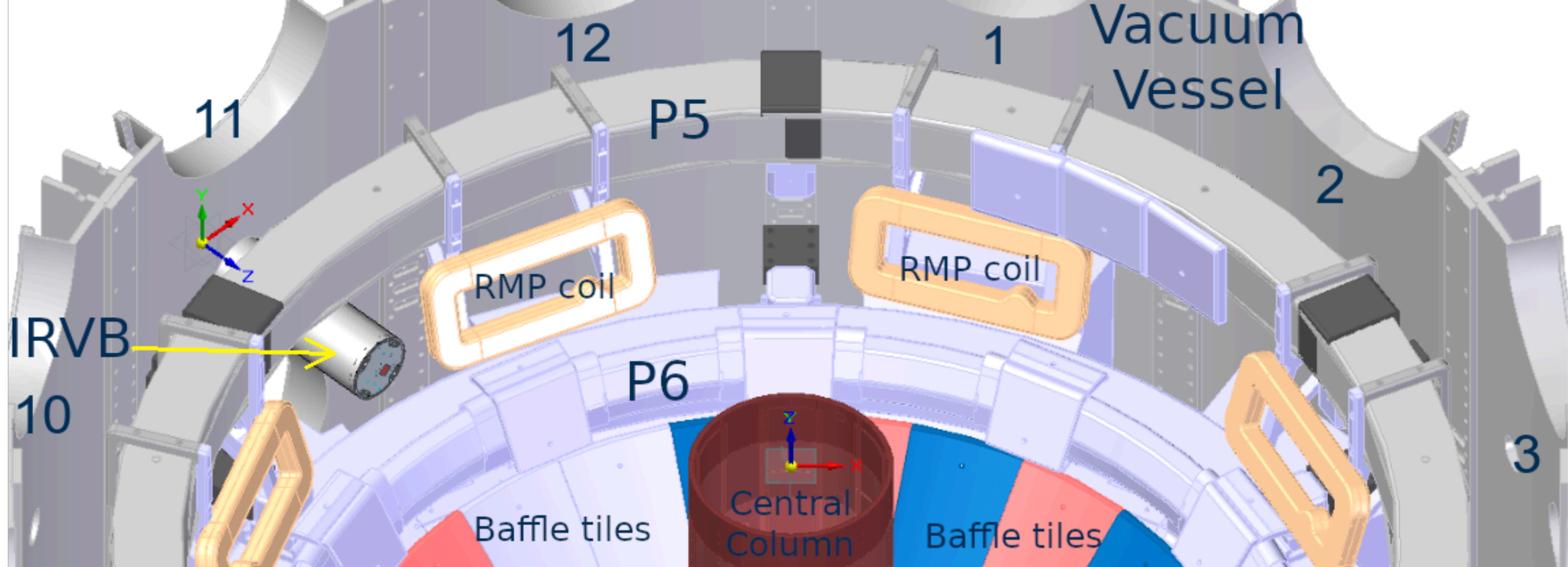

Camera mount (reverse view)

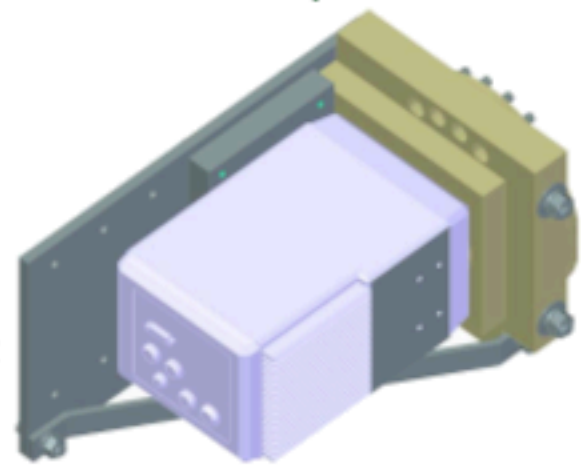
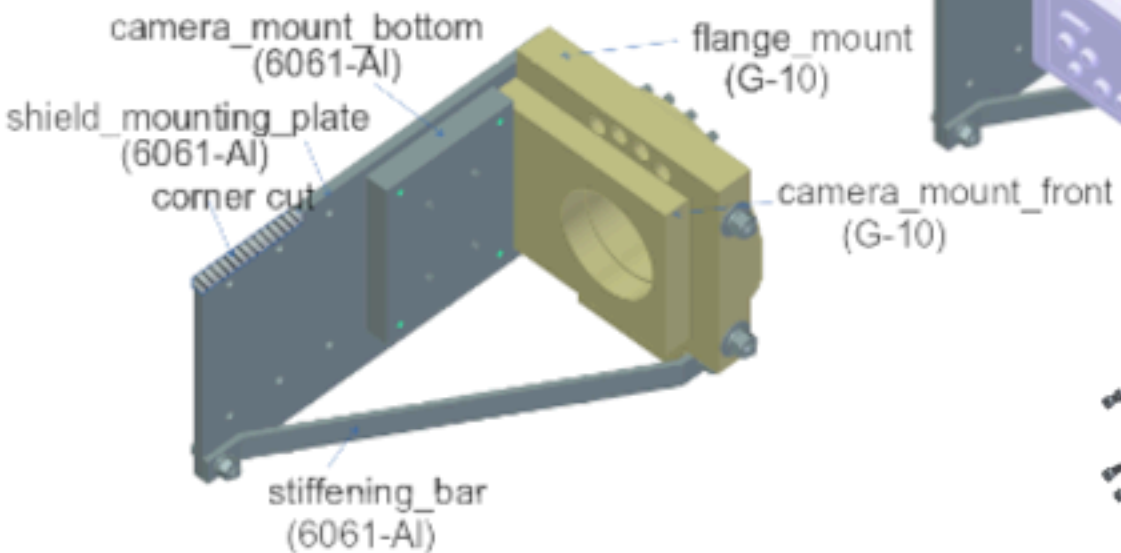

DN200->DN63
zero-length adapter
(Lesker RF1000X450M)

180 mm OD
2 mm wall thickness
SS tube
(need vendor)

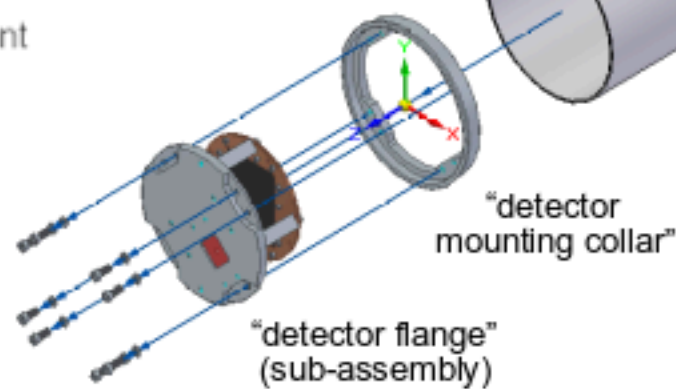

Detector Flange Overview (reverse view)

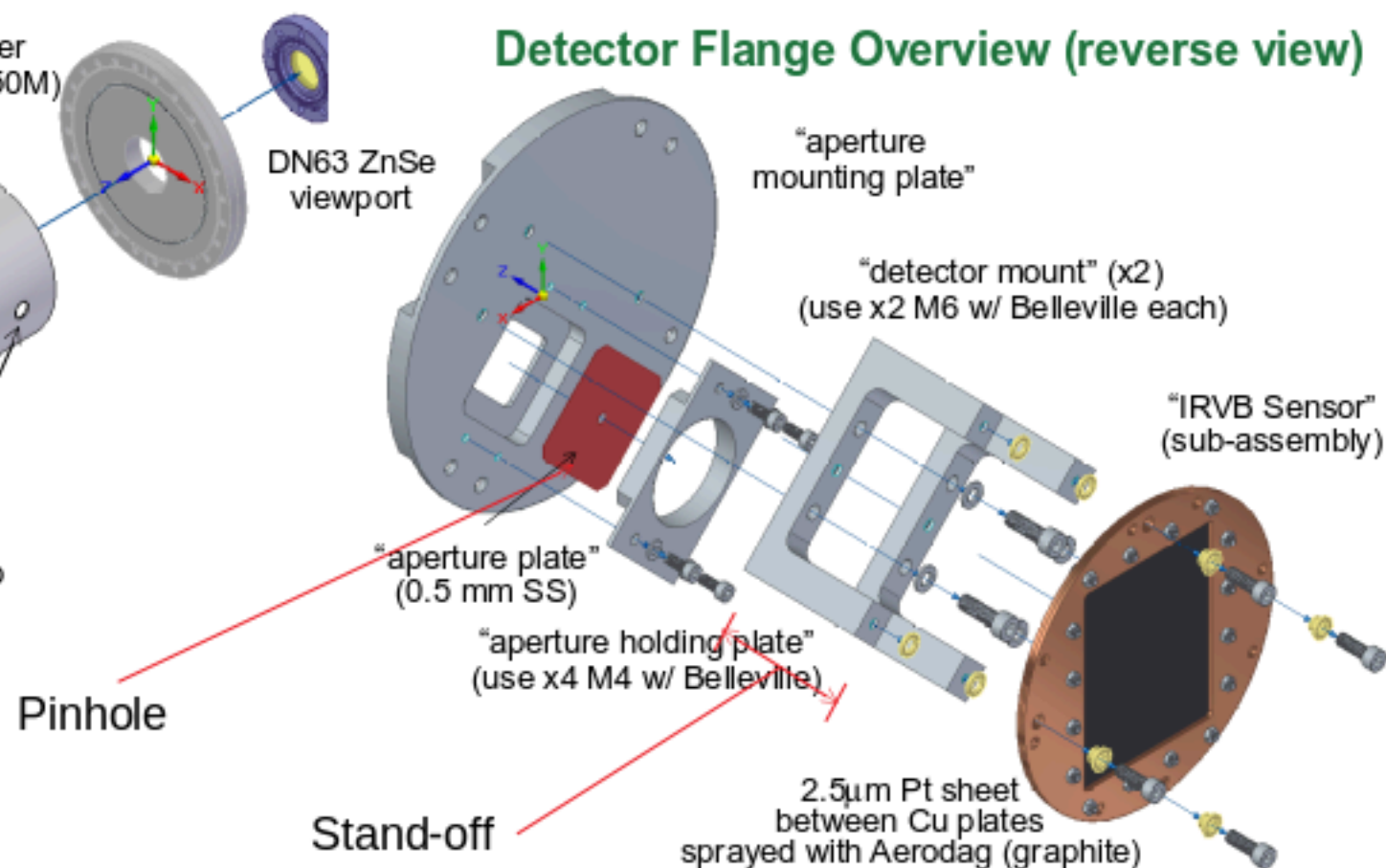







SC7000

FLIR

Power density on the foil generated via CHERAB simulation
Radiator of $r=0.04\text{m}$ at $R=0.55\text{m}$, $Z=-1.2\text{m}$, 0.5MW
standoff= 0.045m , pinhole= 4mm

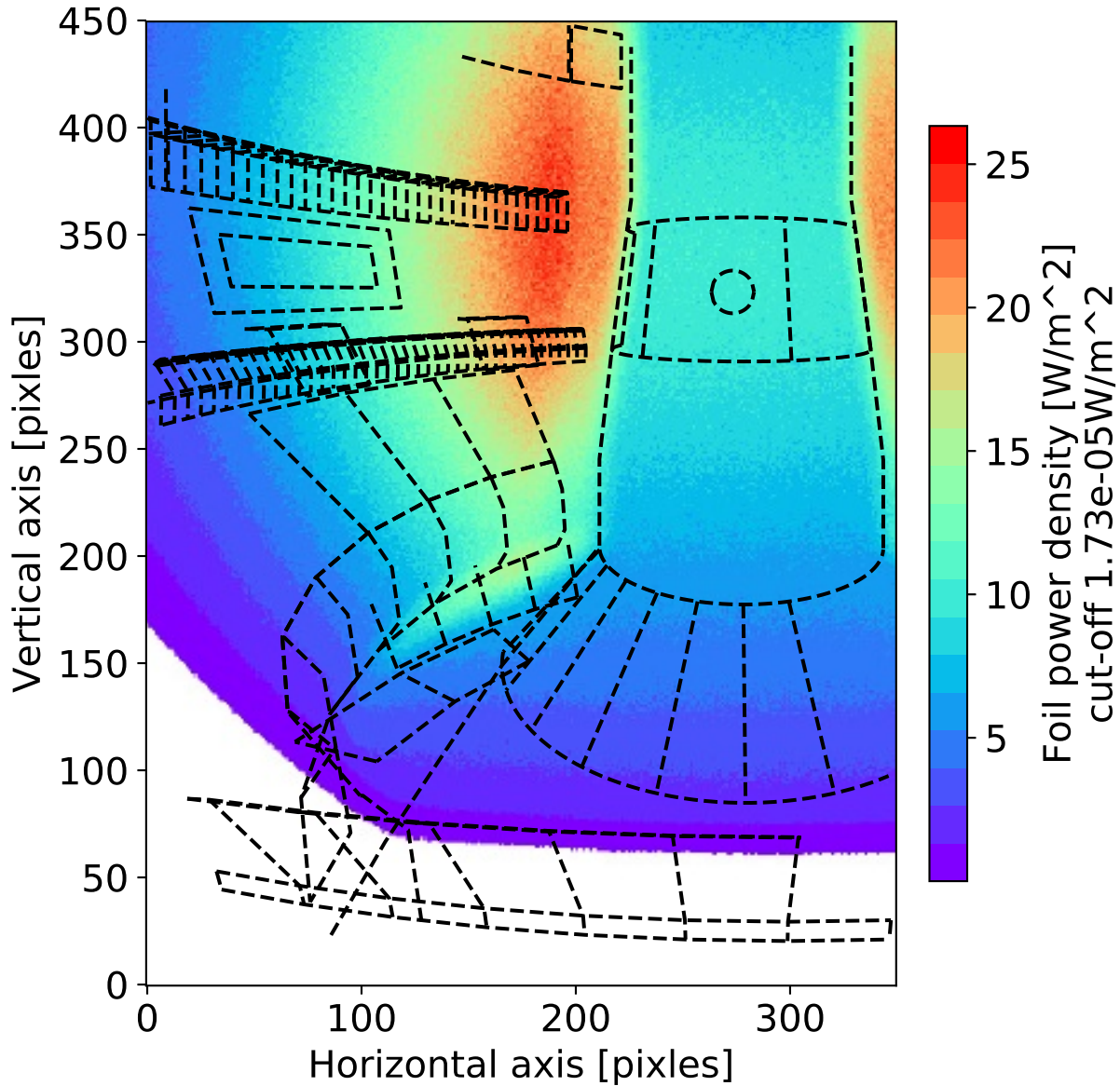

Power density on the foil generated via CHERAB simulation
Radiator of $r=0.04\text{m}$ at $R=0.55\text{m}$, $Z=-1.2\text{m}$, 0.5MW
standoff= 0.045m , pinhole= 4mm

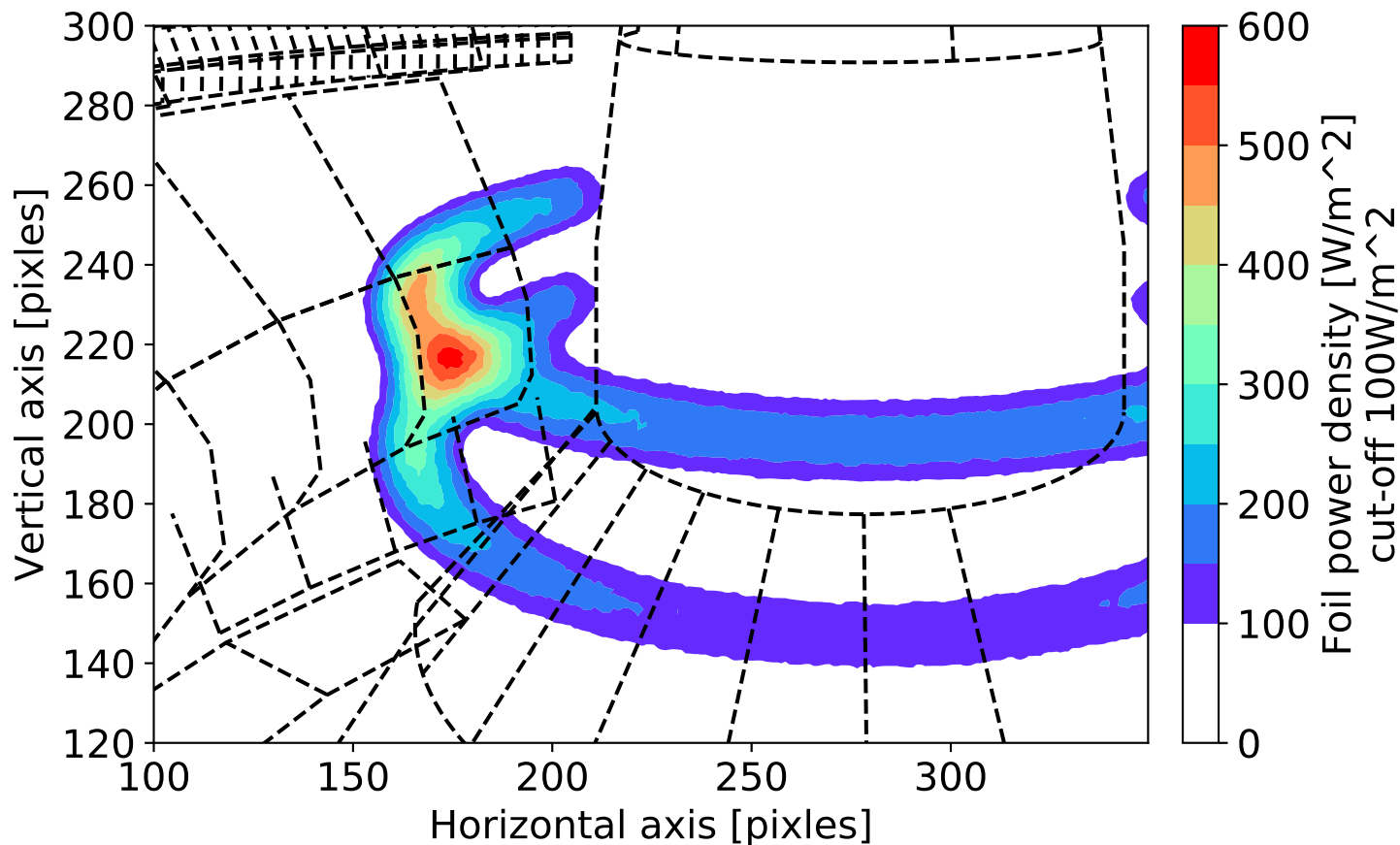

Power density on the foil generated via CHERAB simulation
Radiator of $r=0.04\text{m}$ at $R=0.55\text{m}$, $Z=-1.2\text{m}$, 0.5MW
standoff= 0.045m , pinhole= 6mm

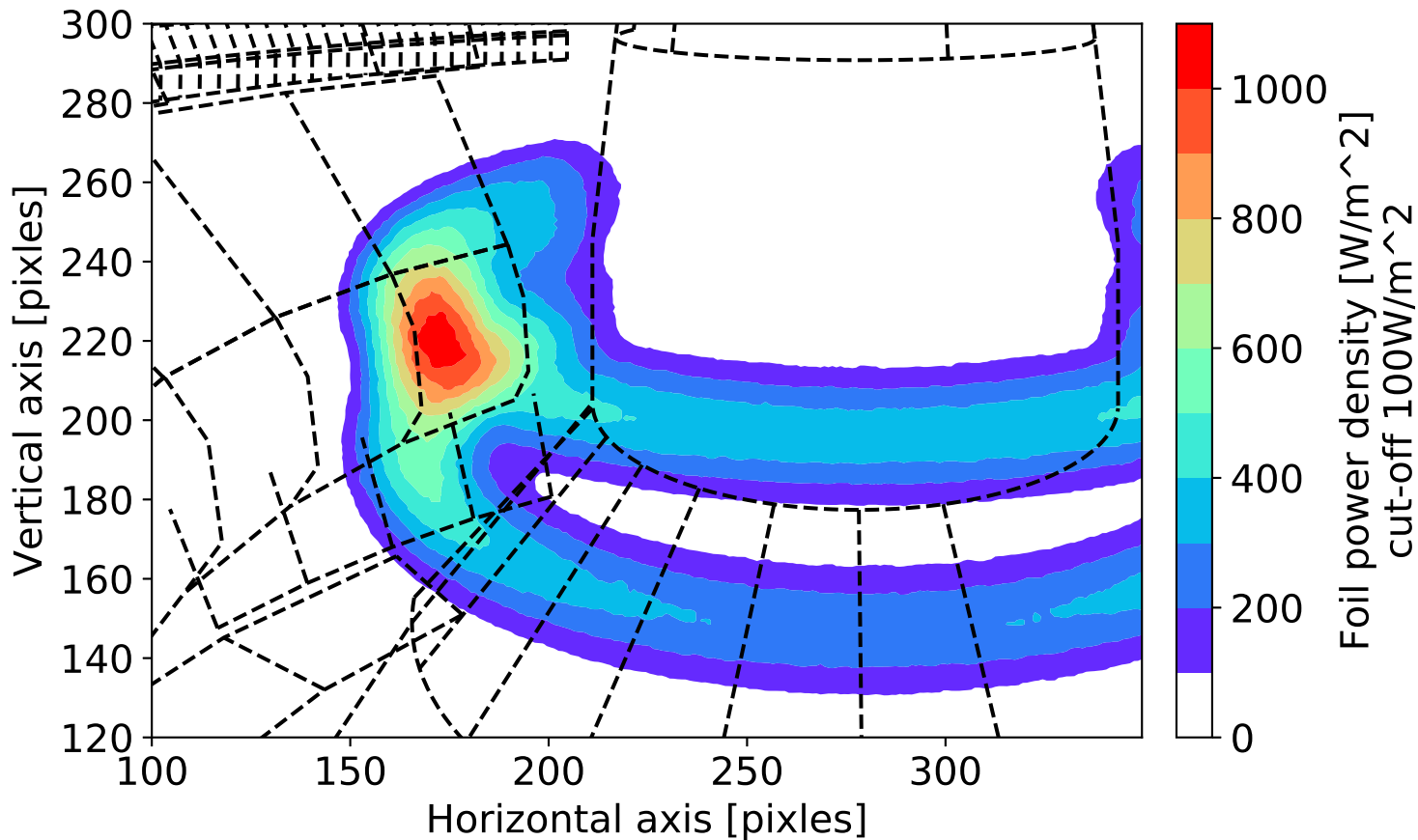

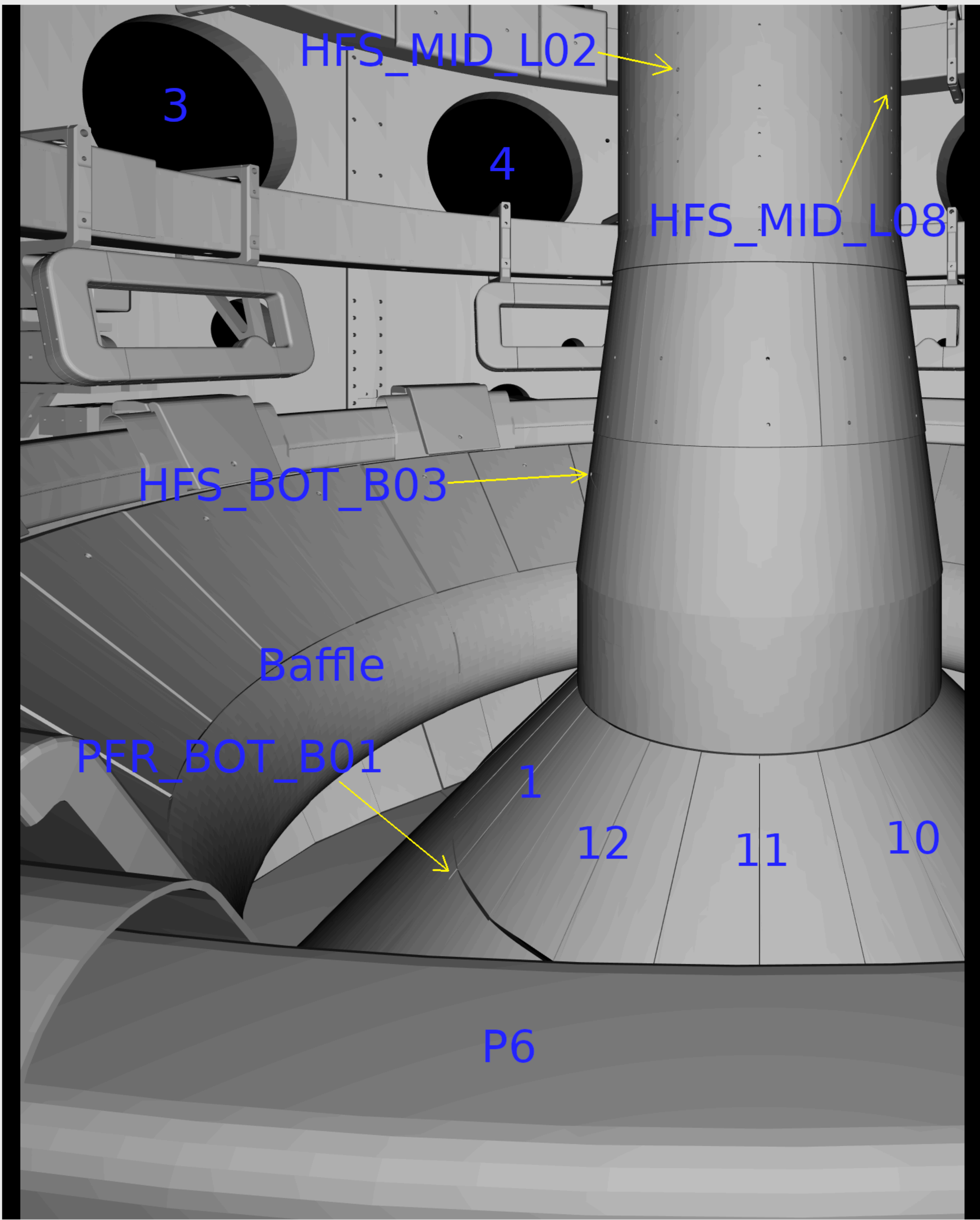

Machine Model Virtual Calibration

Camera Intrinsic

Use intrinsic from existing calibration:

Calibrate from chessboard images:

Use ideal pinhole camera model:

Pixel Size:

Number of pixels: x

Focal Length:

Camera Positioning

Position the virtual camera using mouse controls on the 3D view, or enter coordinates manually below. You can select a preset view or existing calibration to start from.

Start from preset:

- MAST Upgrade
 - HE05-Lower
 - HE05-Upper
 - HL04
 - HL06
 - HM08
 - HM09
 - HM10
 - HU04
 - HU06
 - HU10
 - HU12
- From Calibrations
 - IRVB5
 - IRVB6

Load from existing calibration:

Cam X: Target X:

Cam Y: Target Y:

Cam Z: Target Z:

Cam Roll:

Mouse Control Settings

Right click + drag: Look around Rotate model

Mouse sensitivity:

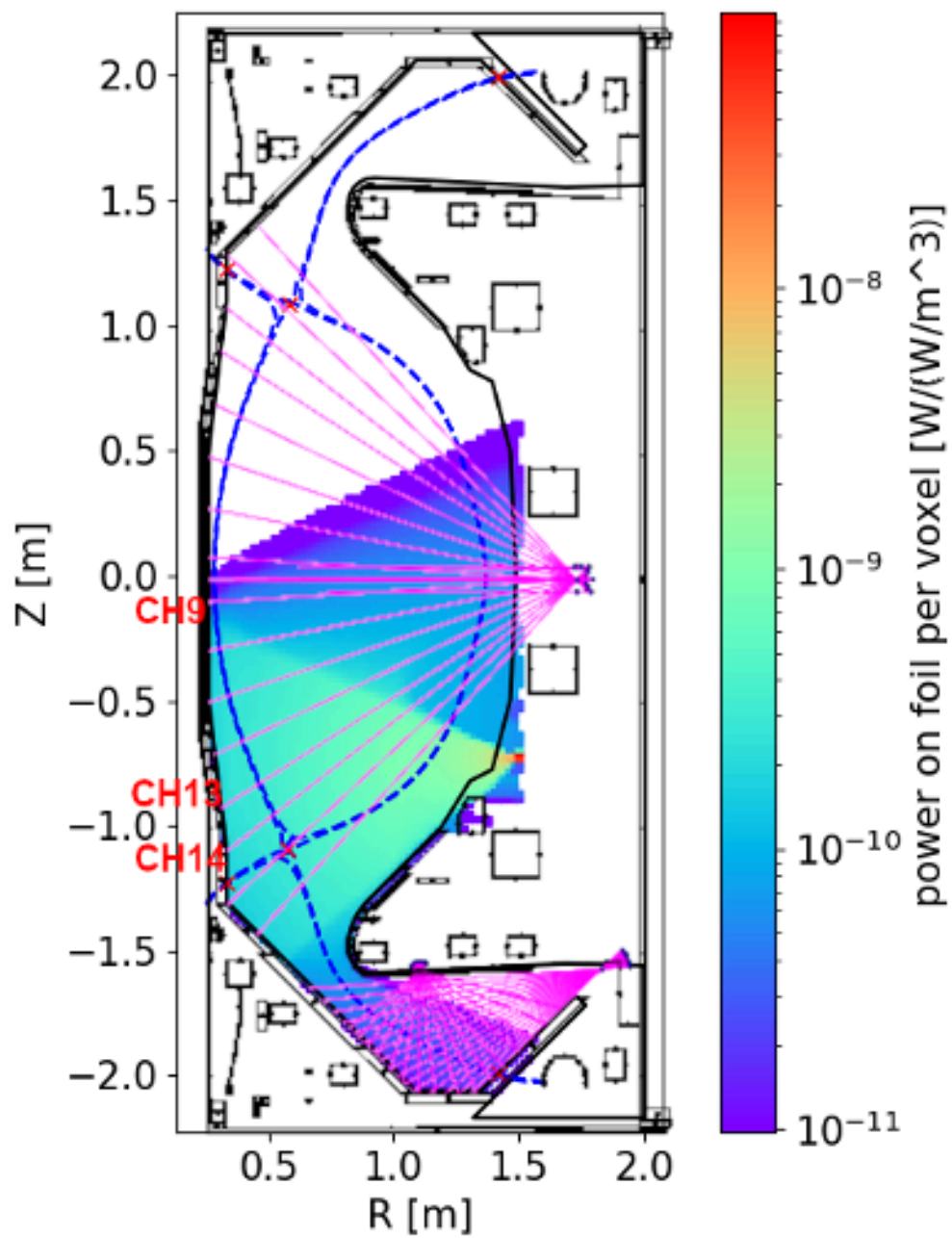

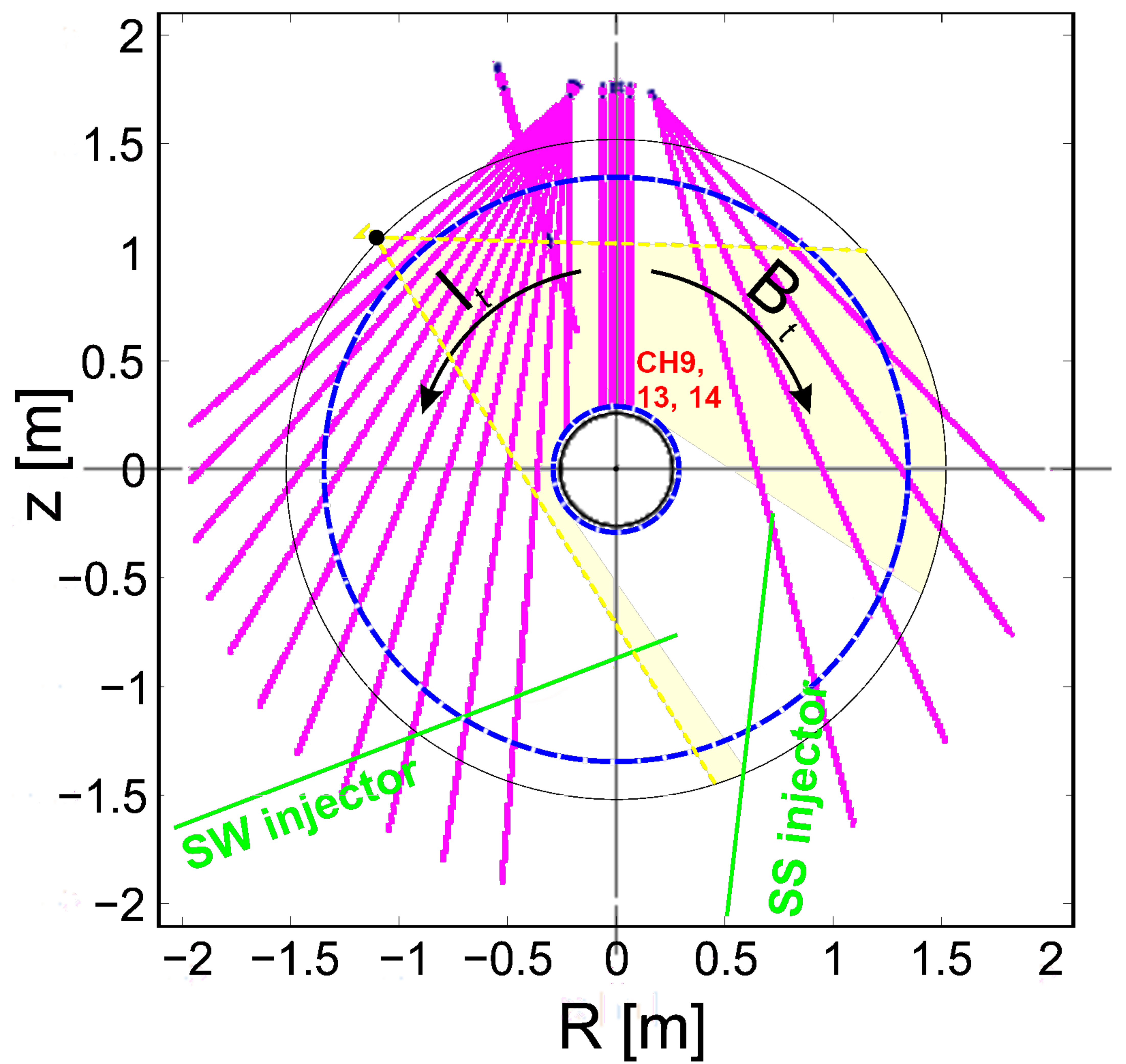

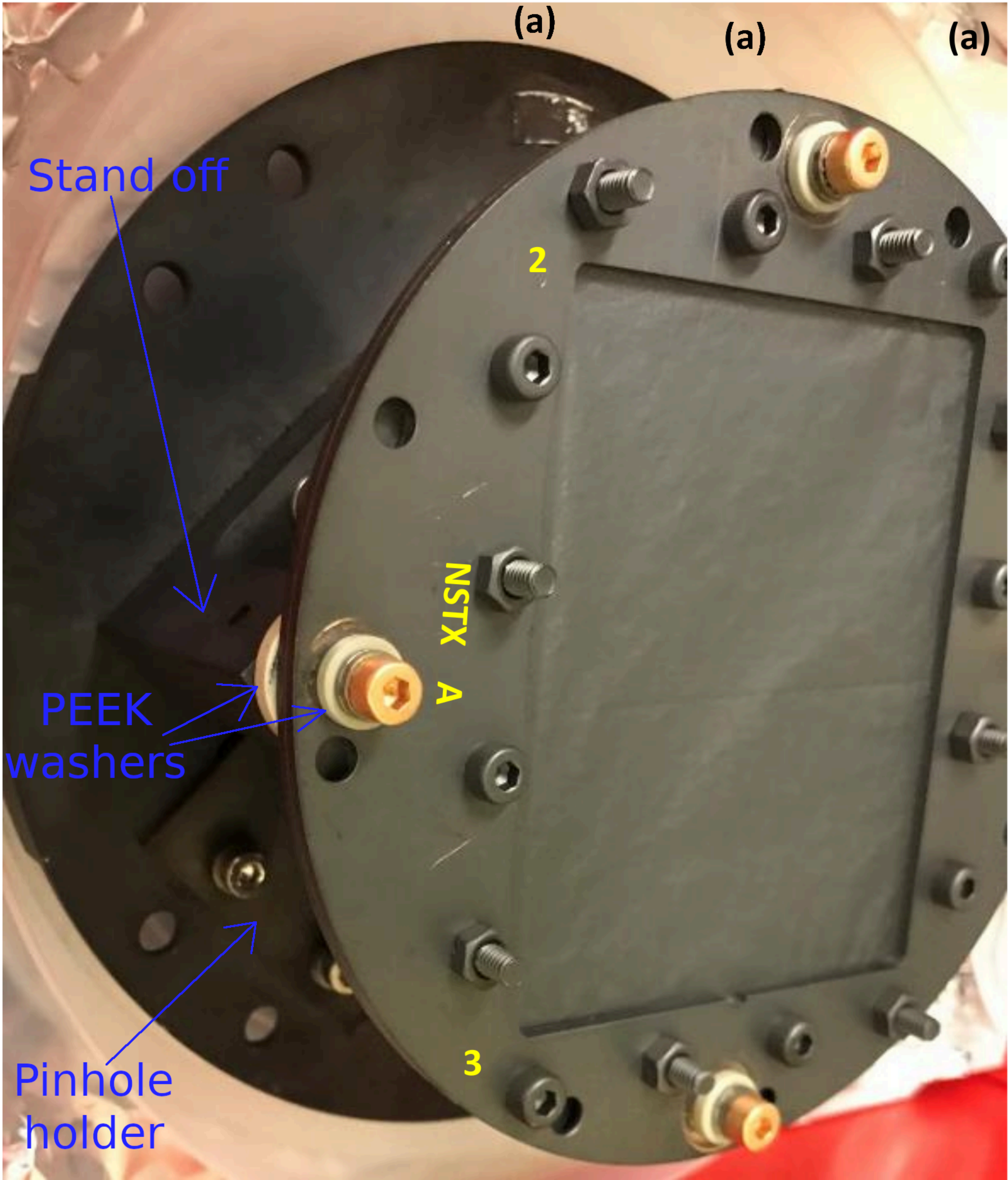

(a)

(a)

(a)

Stand off

2

NSTX A

PEEK washers

3

Pinhole holder

(b)

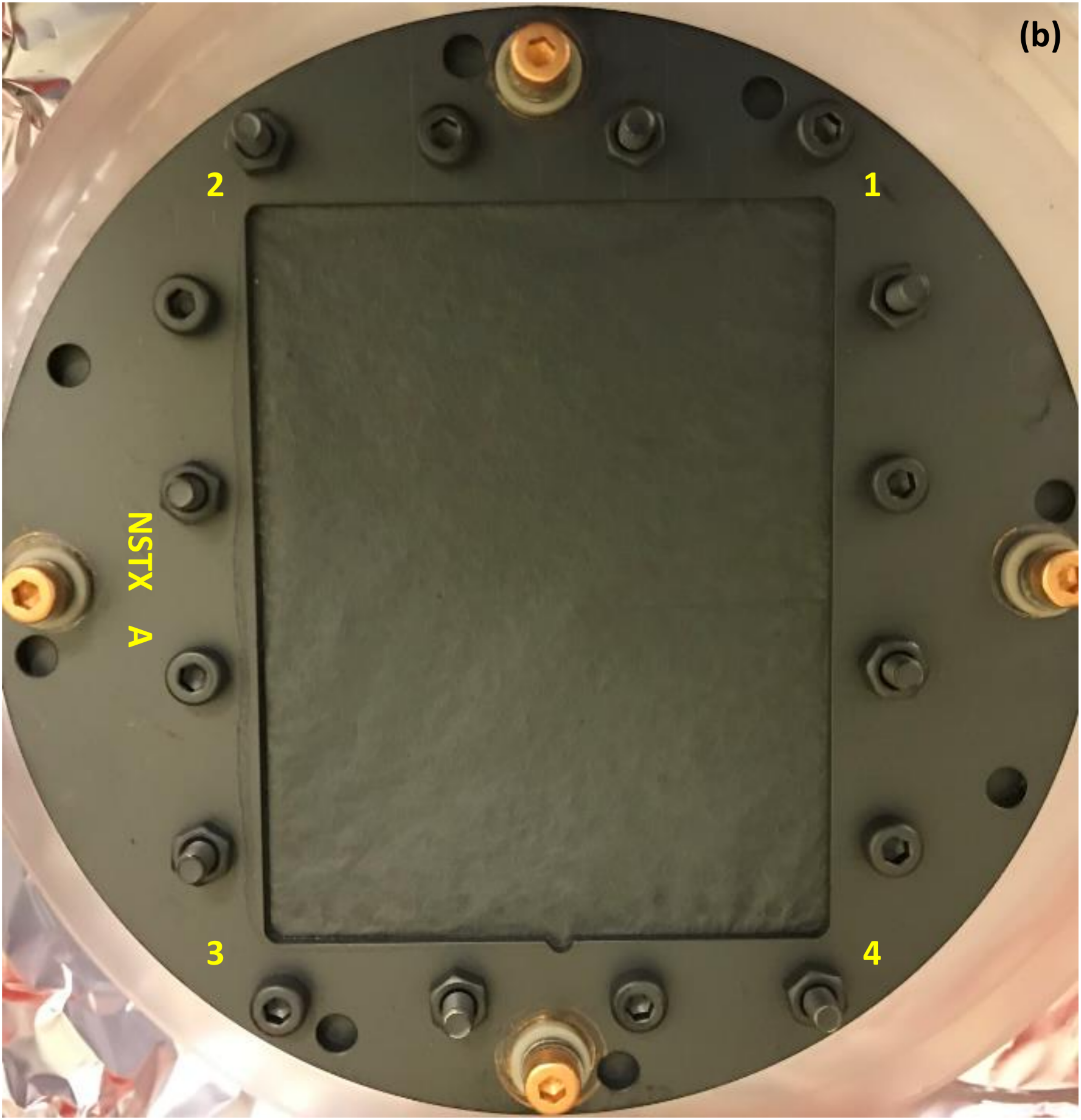

NSTX A

2

1

3

4

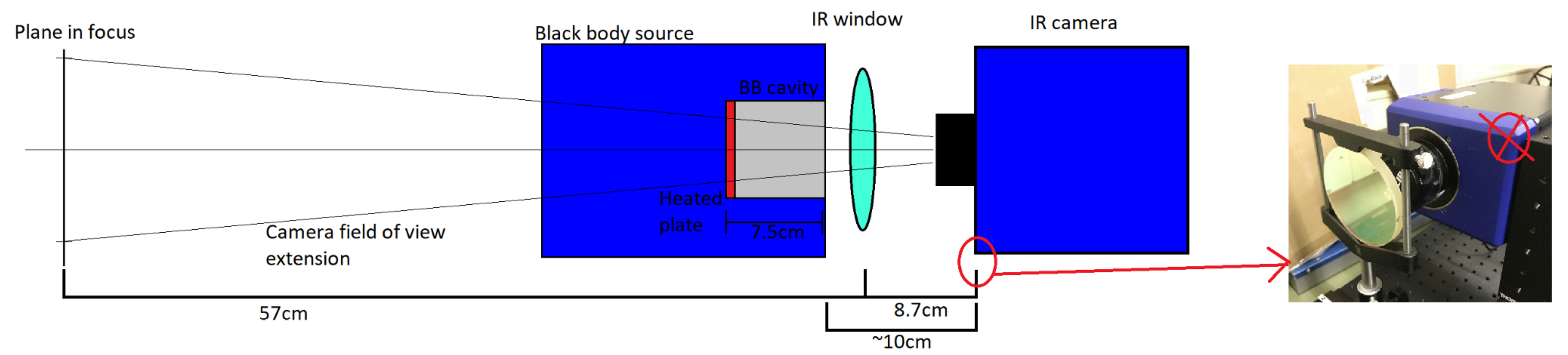
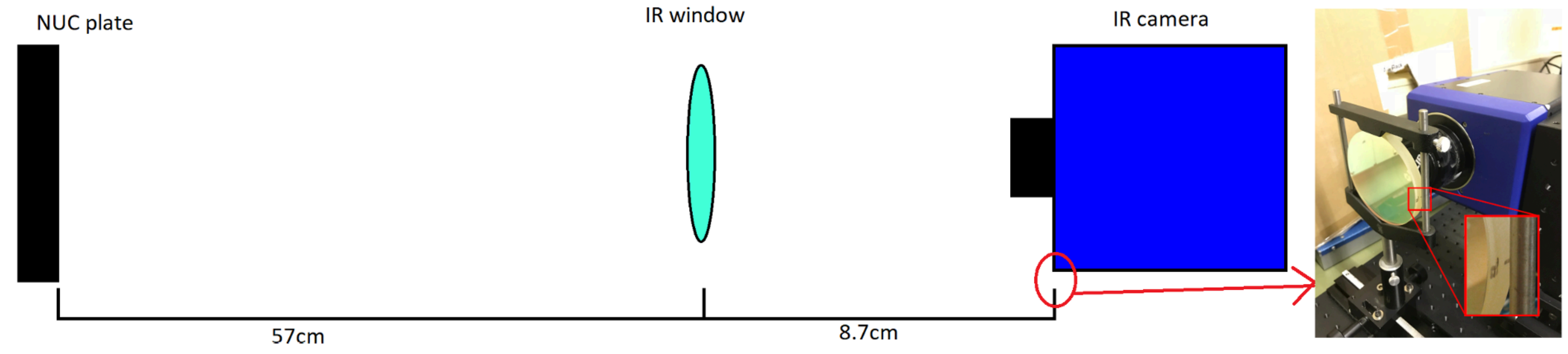
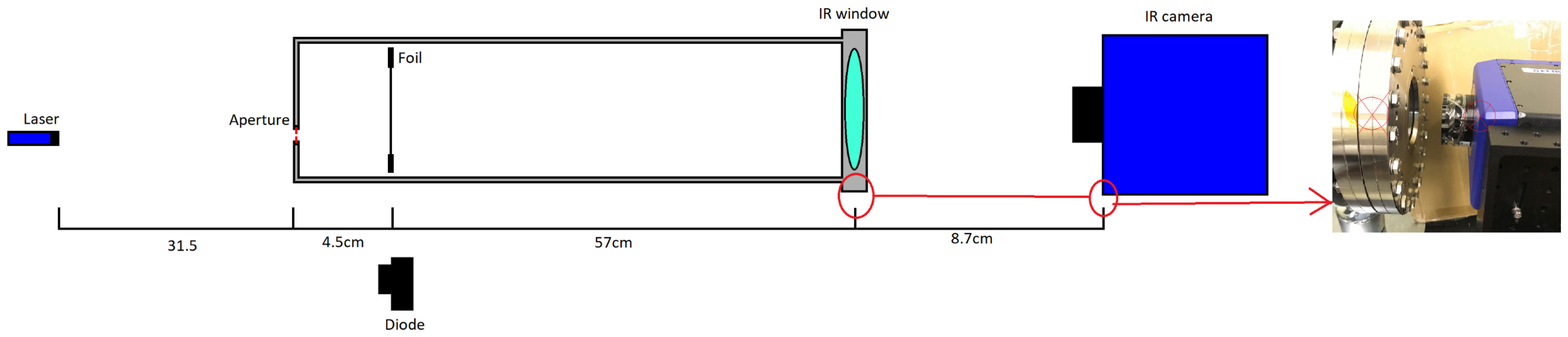

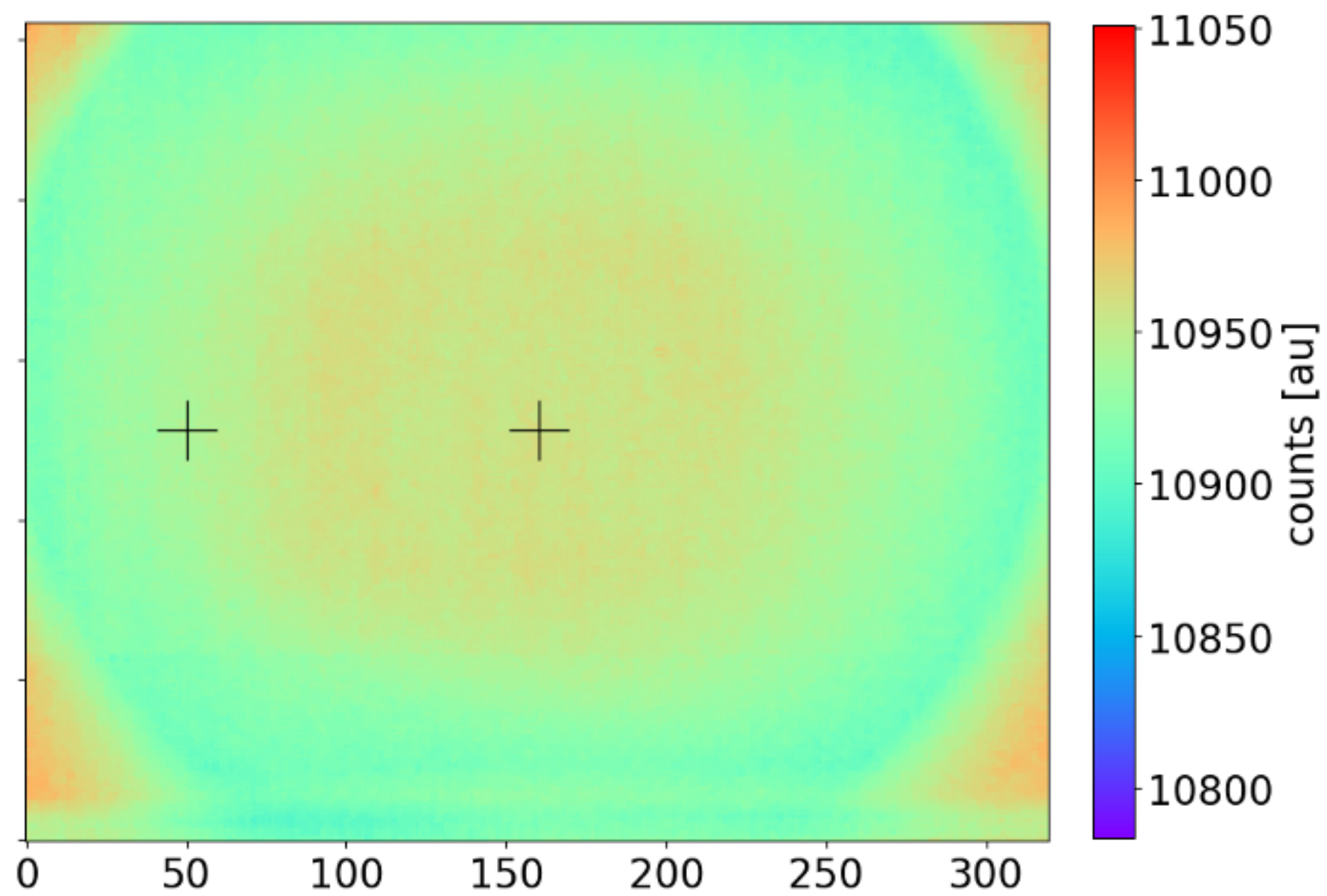

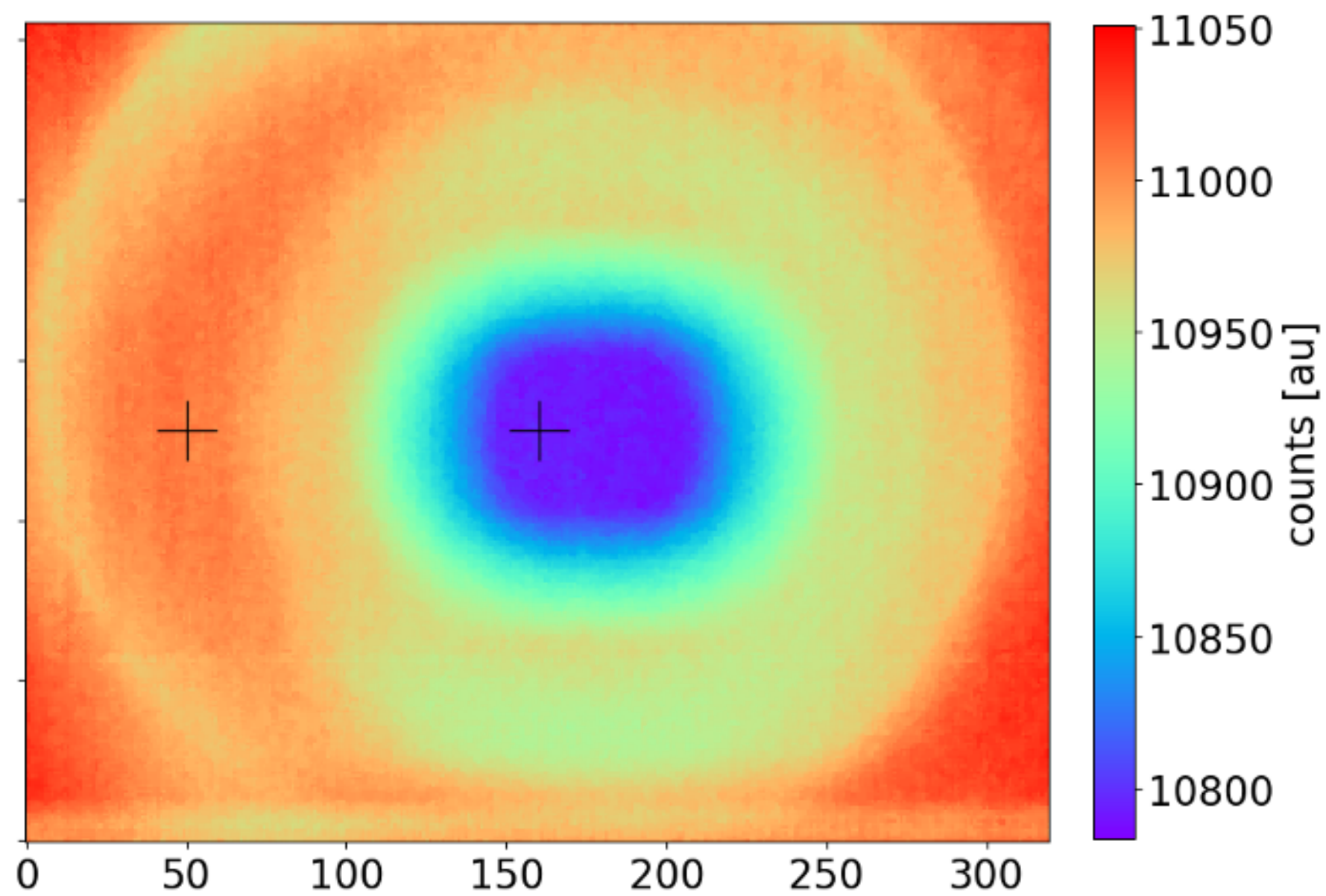

Foil search in /home/ffederic/work/irvb/MAST-U/2021-10-28/IRVB-MASTU_shot-45473.ptw
Foil center [157, 136], foil rot 0.7deg, foil size [240, 187]pixel

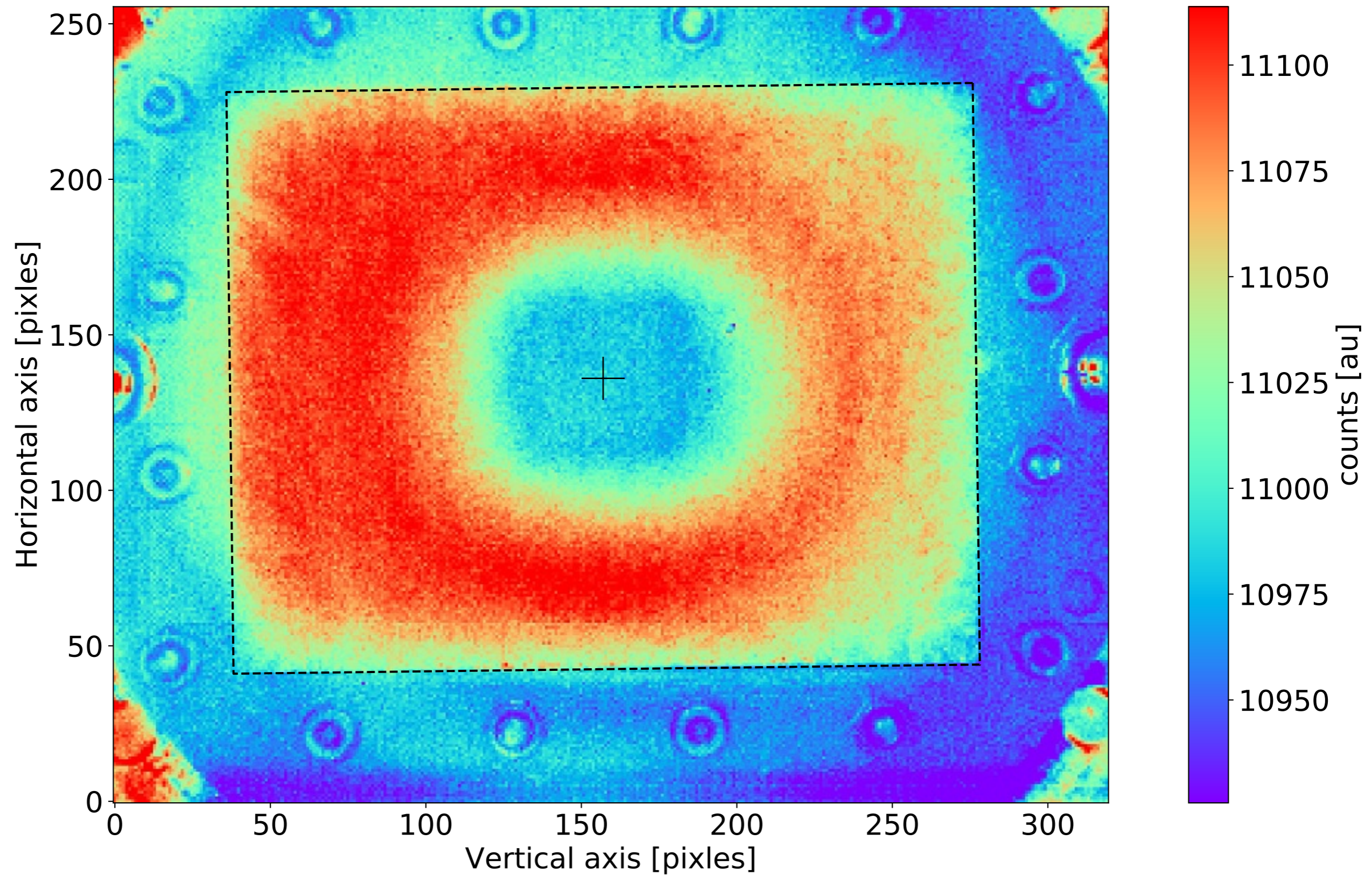

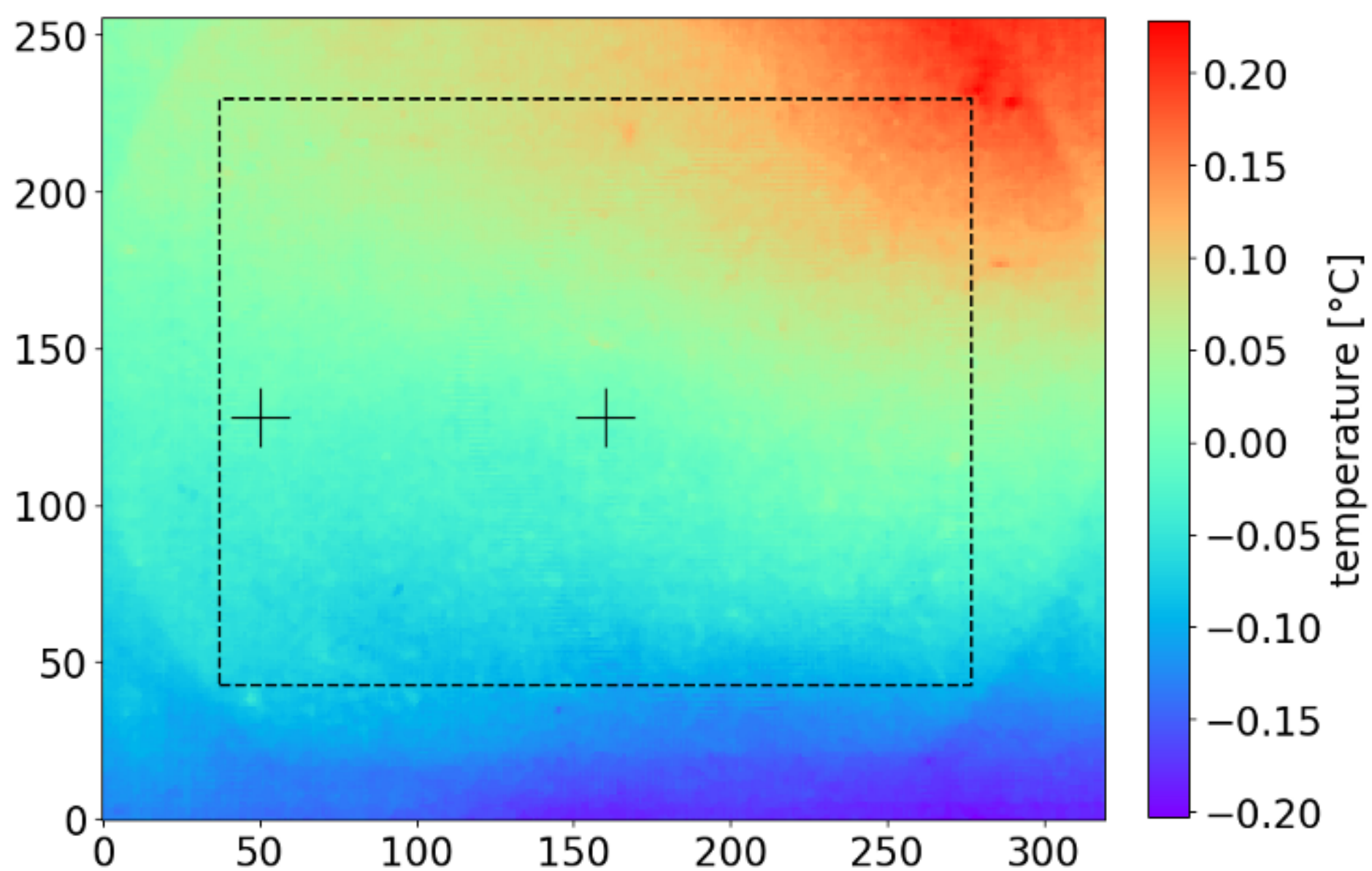

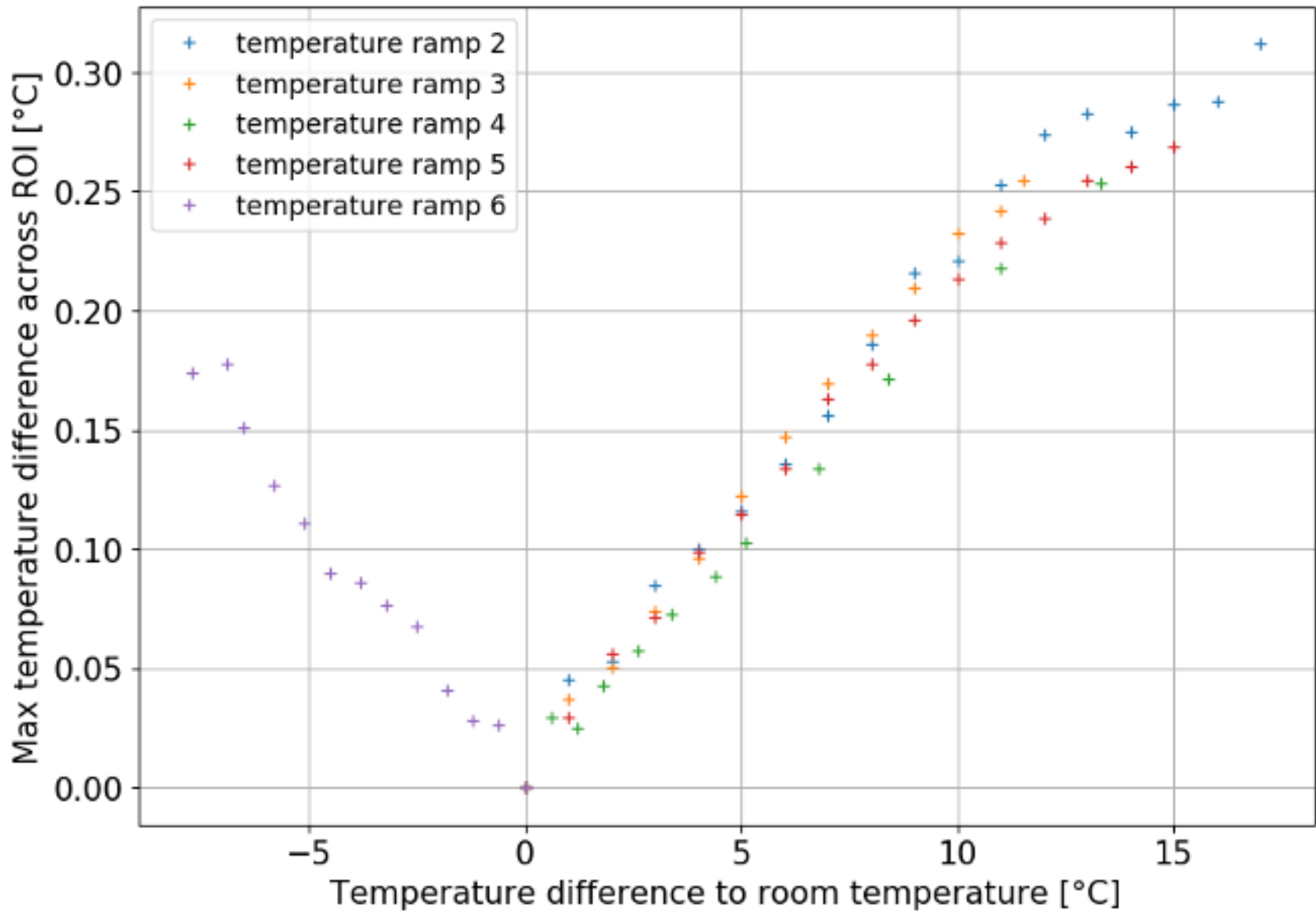

digitizer,j,k=(0, 128, 160)

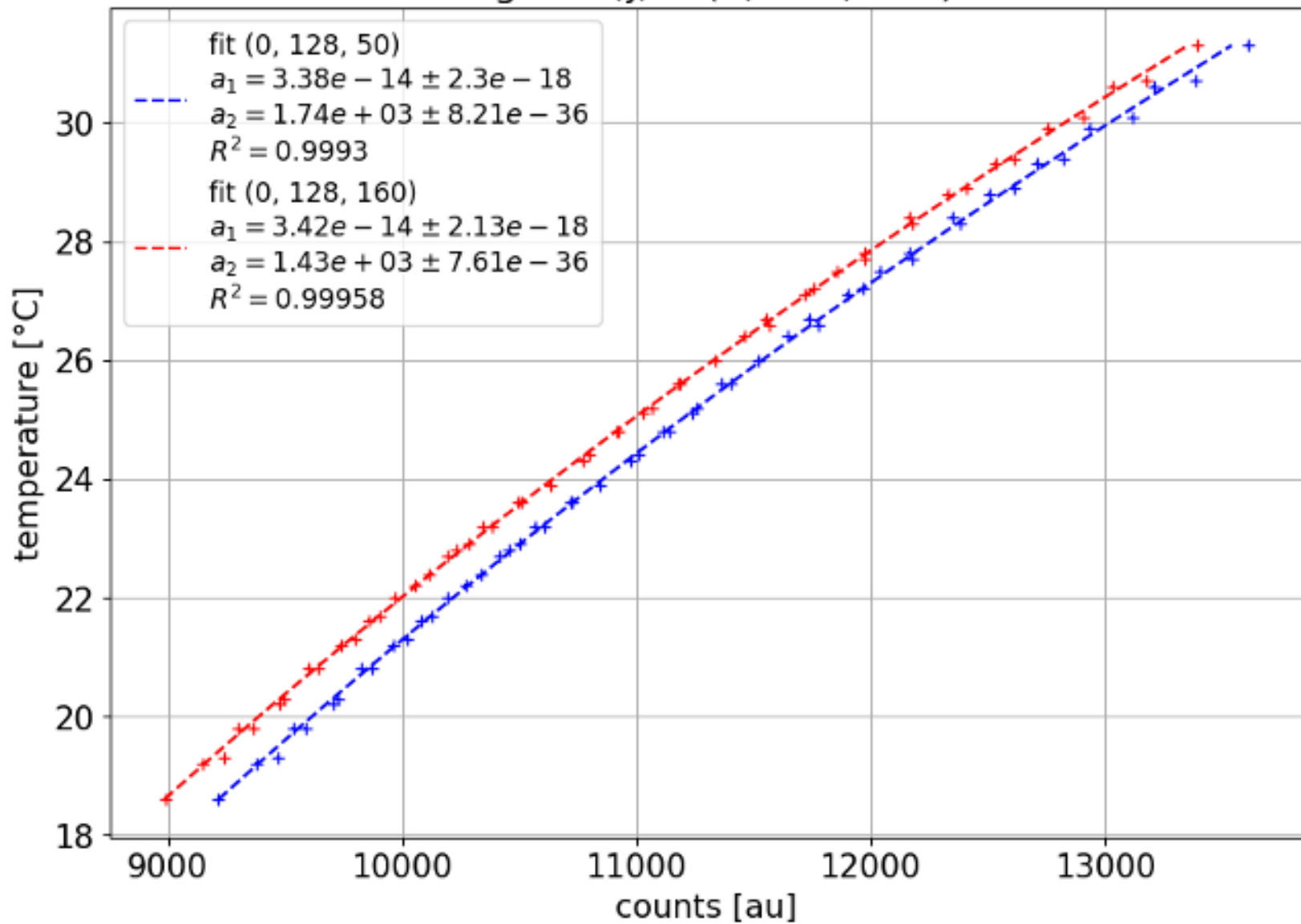

proportional pure window component BB curve fit NUC
NUC plate original scans with window inttime=2.0 # ms

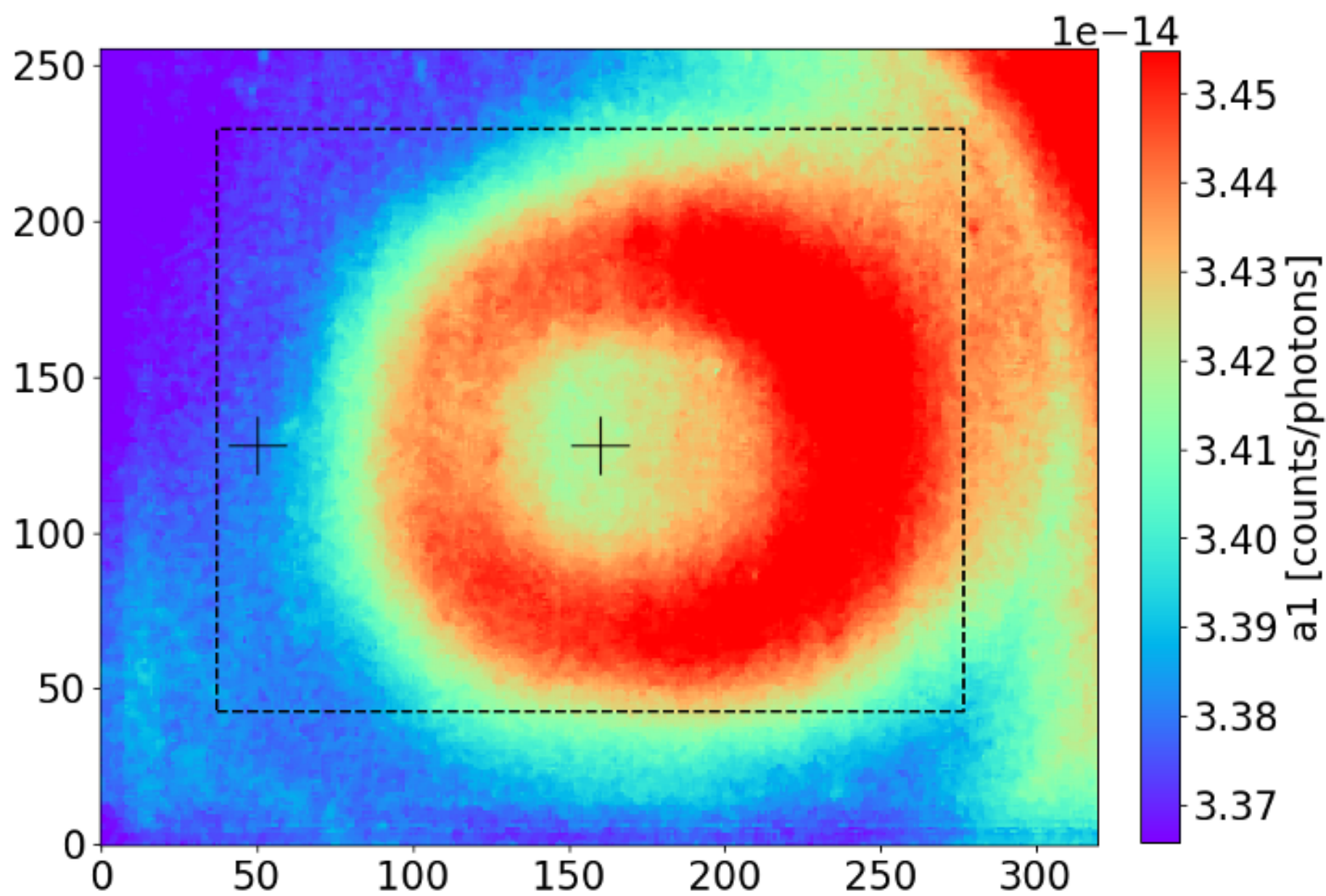

constant pure window component BB curve fit NUC
NUC plate original scans with window inttime=2.0 # ms

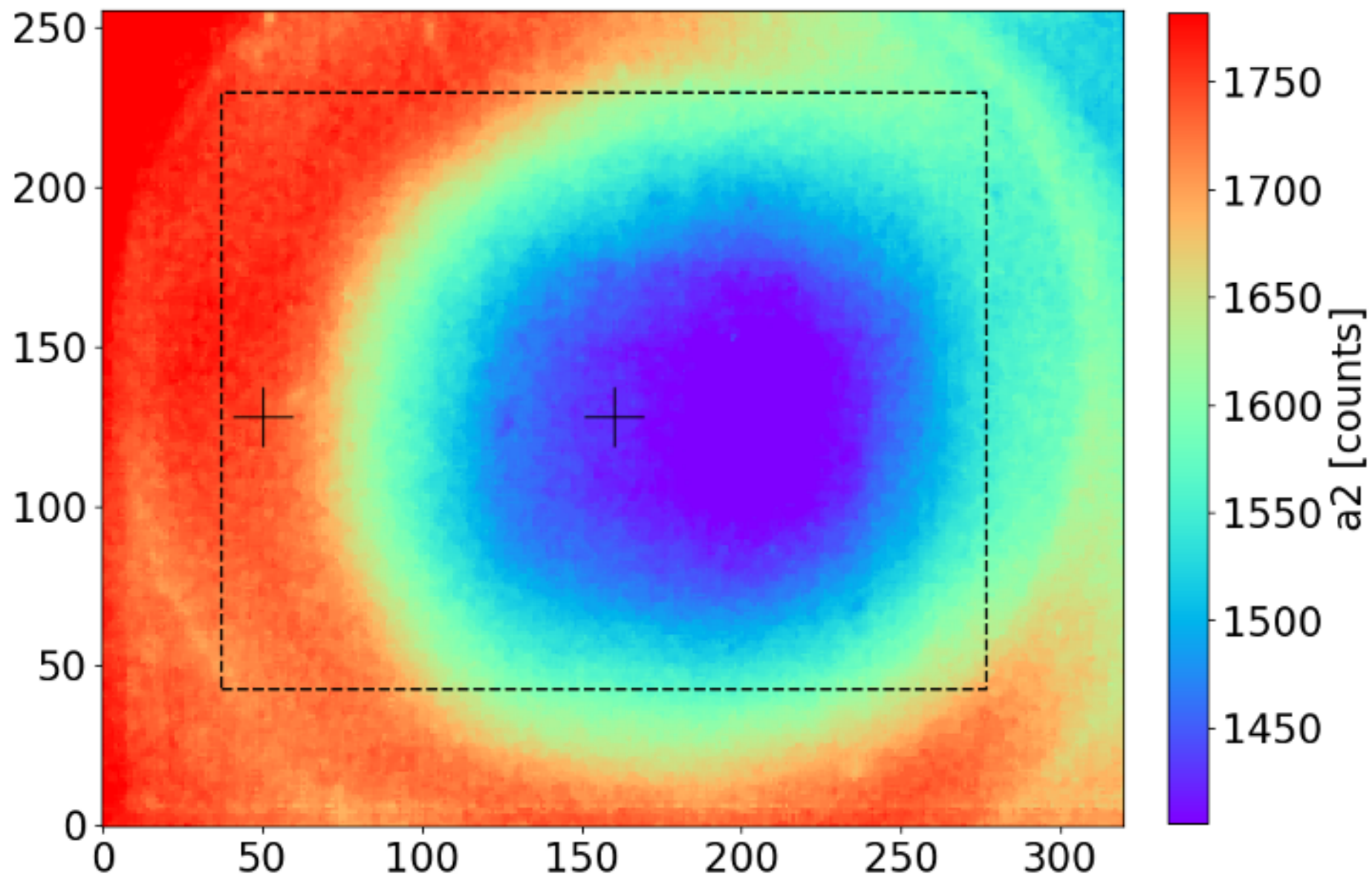

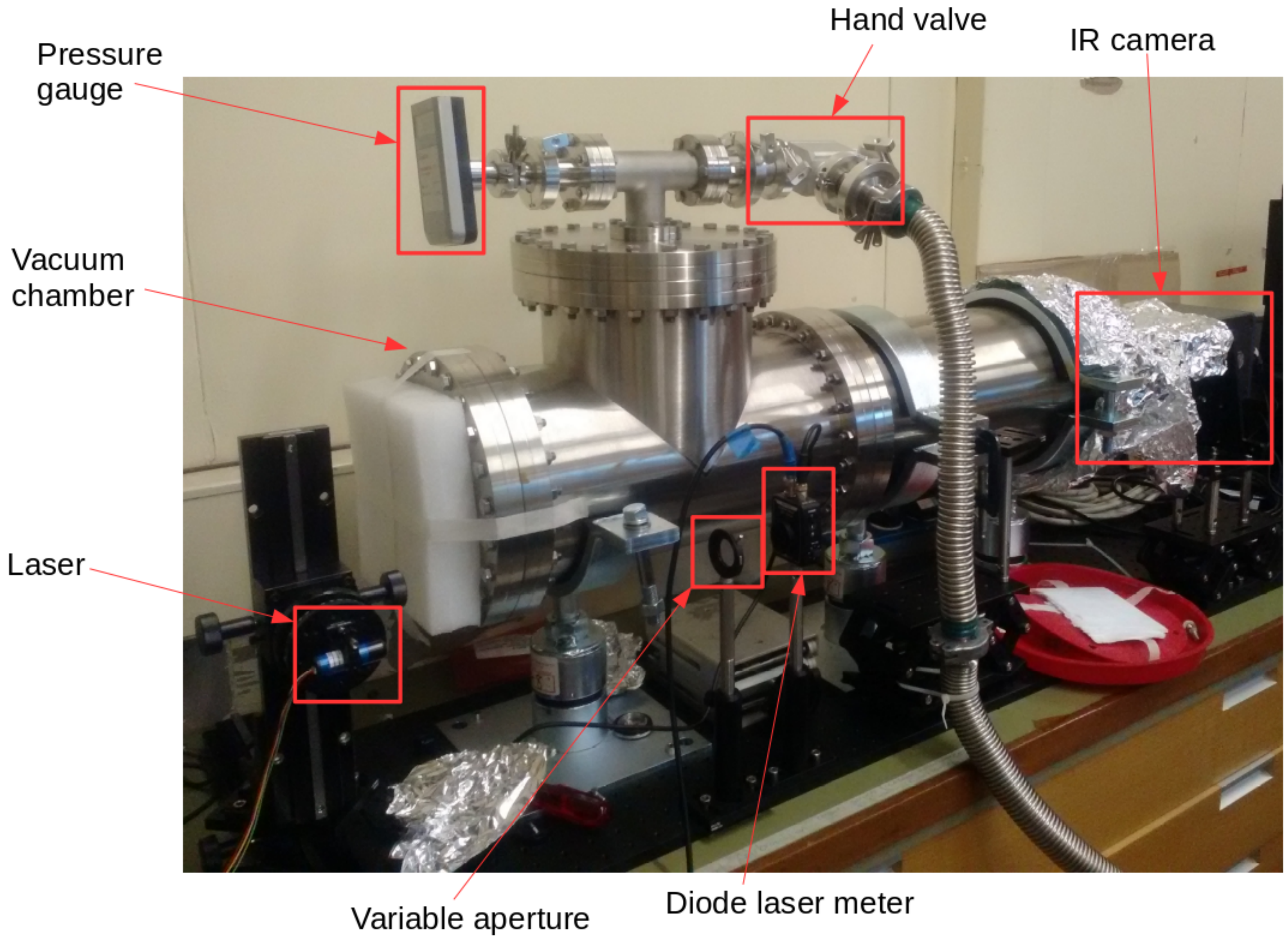

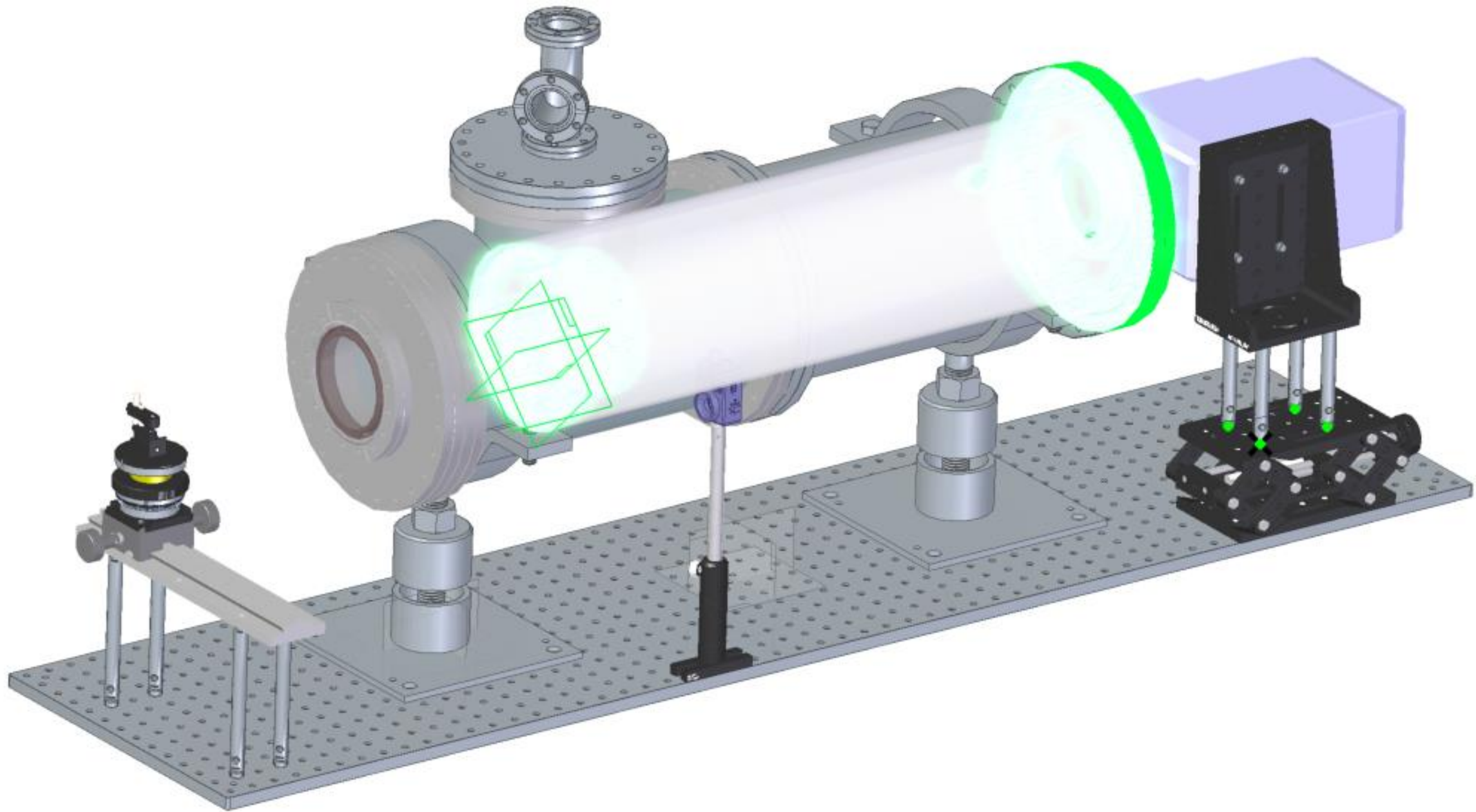

/home/ffederic/work/irvb/laser/Aug20_2018/irvb_full-000005 in laser22

Input focused, spot location [188, 42] power 0.00388W, freq 0.2Hz, duty0.5

High Power=0.00393+/-0W, Low Power=-2.45e-05+/-0W, sharpness=1.91

diffusivity 1.35e-05,thickness 2.69e-06,emissivity 1,defocused_to_focused 1.03,laser_through_mirror_correction 1

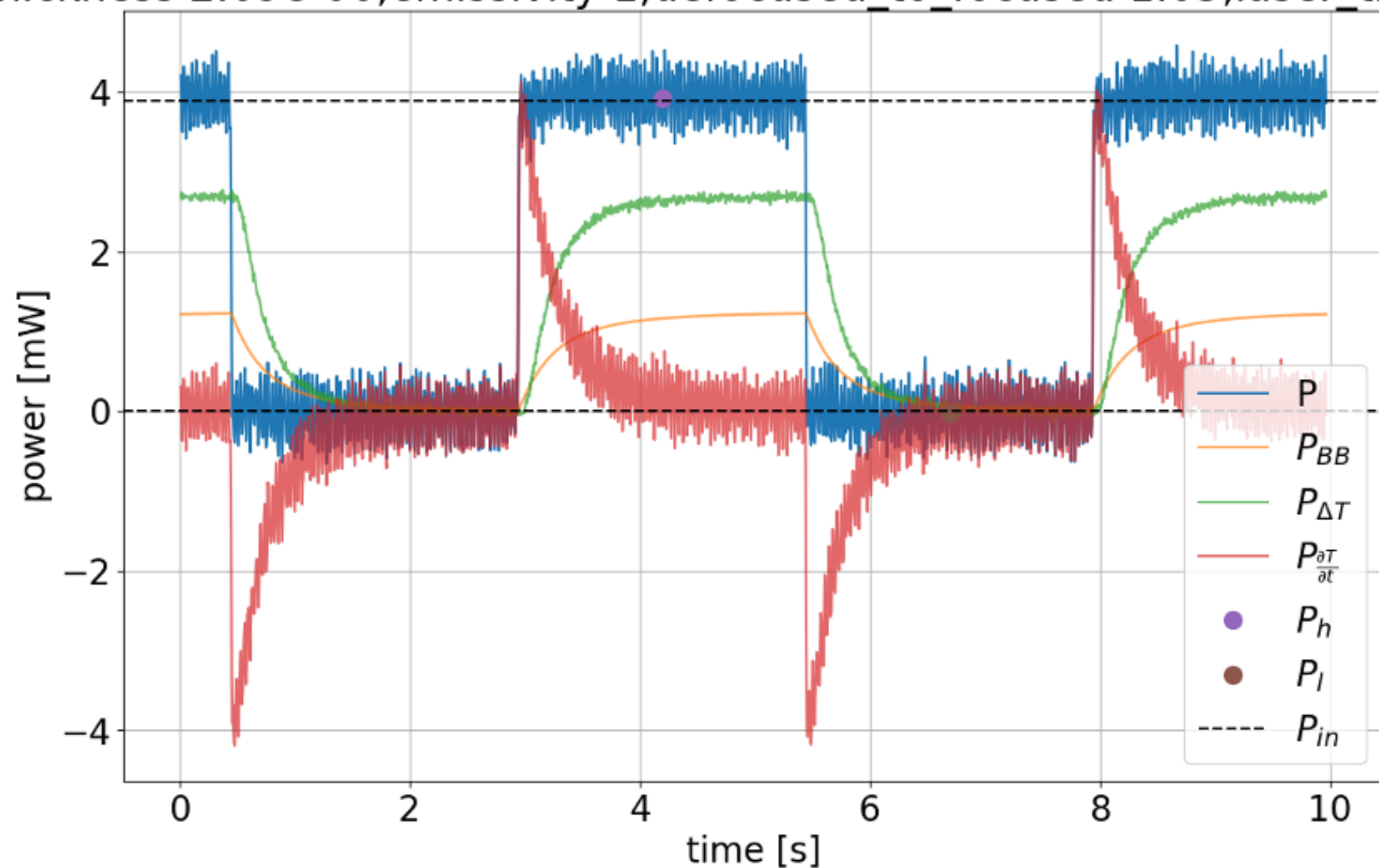

/home/ffederic/work/irvb/laser/Aug20_2018/irvb_full-000010 in laser22

Input focused, spot location [188, 42] power 0.00388W, freq 10Hz, duty0.5

High Power= $0.00391 \pm 3.73e-05$ W, Low Power= $-2.92e-05 \pm 3.28e-05$ W, sharpness=1.3

diffusivity $1.35e-05$, thickness $2.69e-06$, emissivity 1, defocused_to_focused 1.03, laser_through_mirror_correction 1

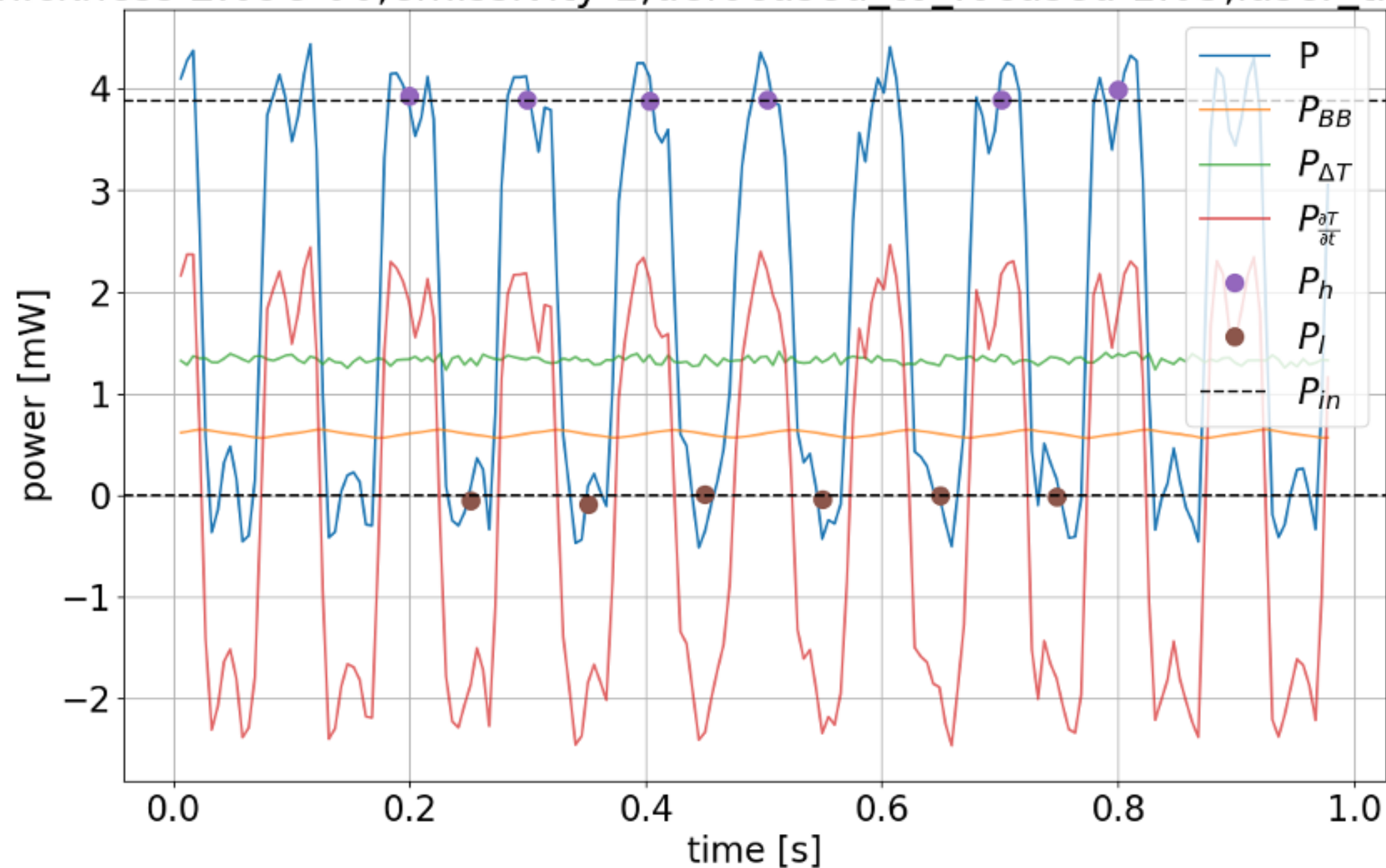

/home/ffederic/work/irvb/laser/Aug23_2018/irvb_full-000006 in laser33

Input fully_defocused, spot location [188, 42] power 0.00101W, freq 0.2Hz, duty0.5

High Power= $0.001 \pm 4.68 \times 10^{-6}$ W, Low Power= $-9.56 \times 10^{-6} \pm 2.81 \times 10^{-6}$ W, sharpness=1.97

diffusivity 1.35×10^{-5} , thickness 2.69×10^{-6} , emissivity 1, defocused_to_focused 1.03, laser_through_mirror_correction 1

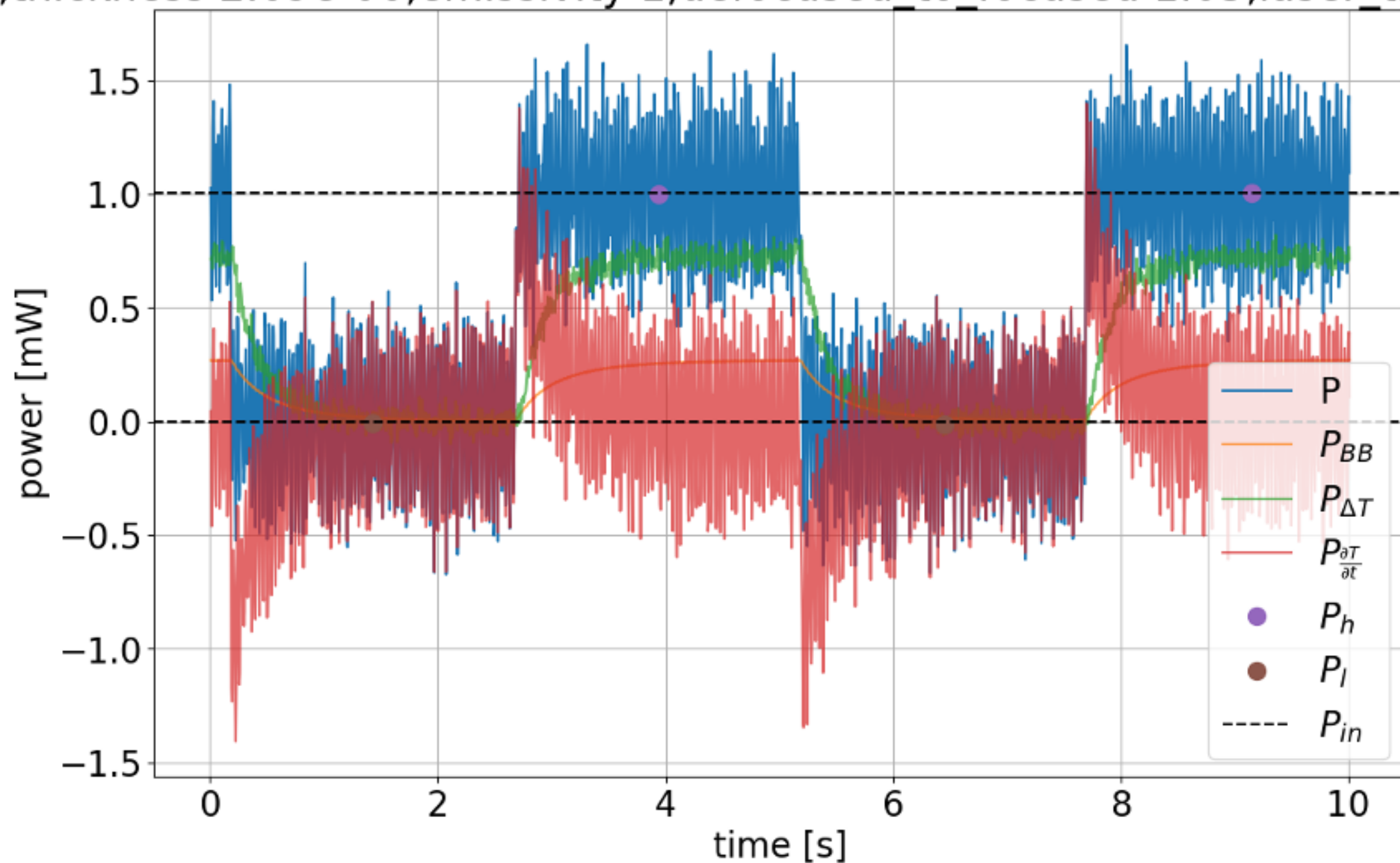

nominal properties
spot location [188, 42]

diffusivity 1.35e-05,thickness 2.69e-06,emissivity 1,defocused_to_focused 1.03,laser_through_mirror_correction 1

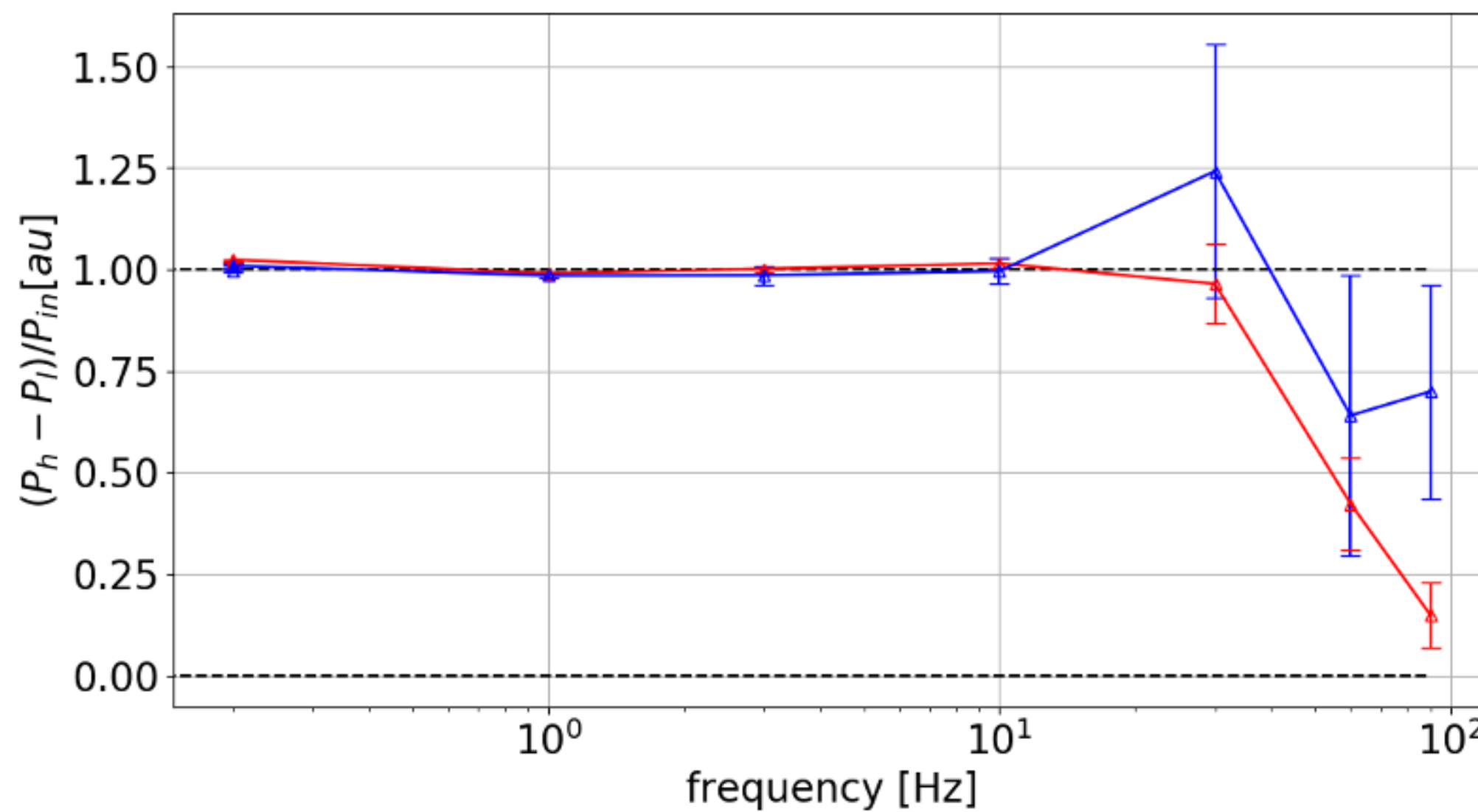
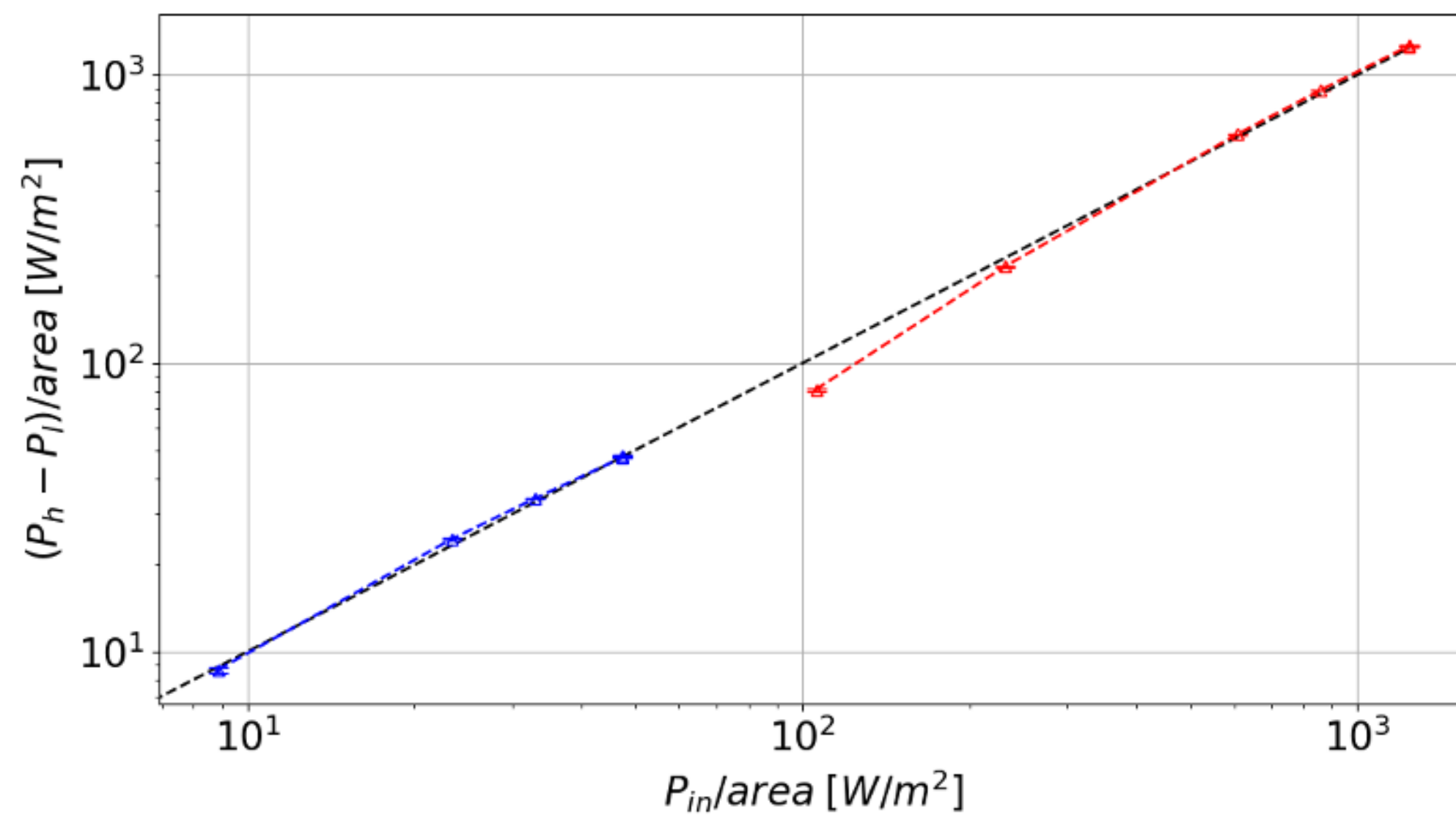

P5

10

11

12

1

3

4

5

6

9 8 7

P5

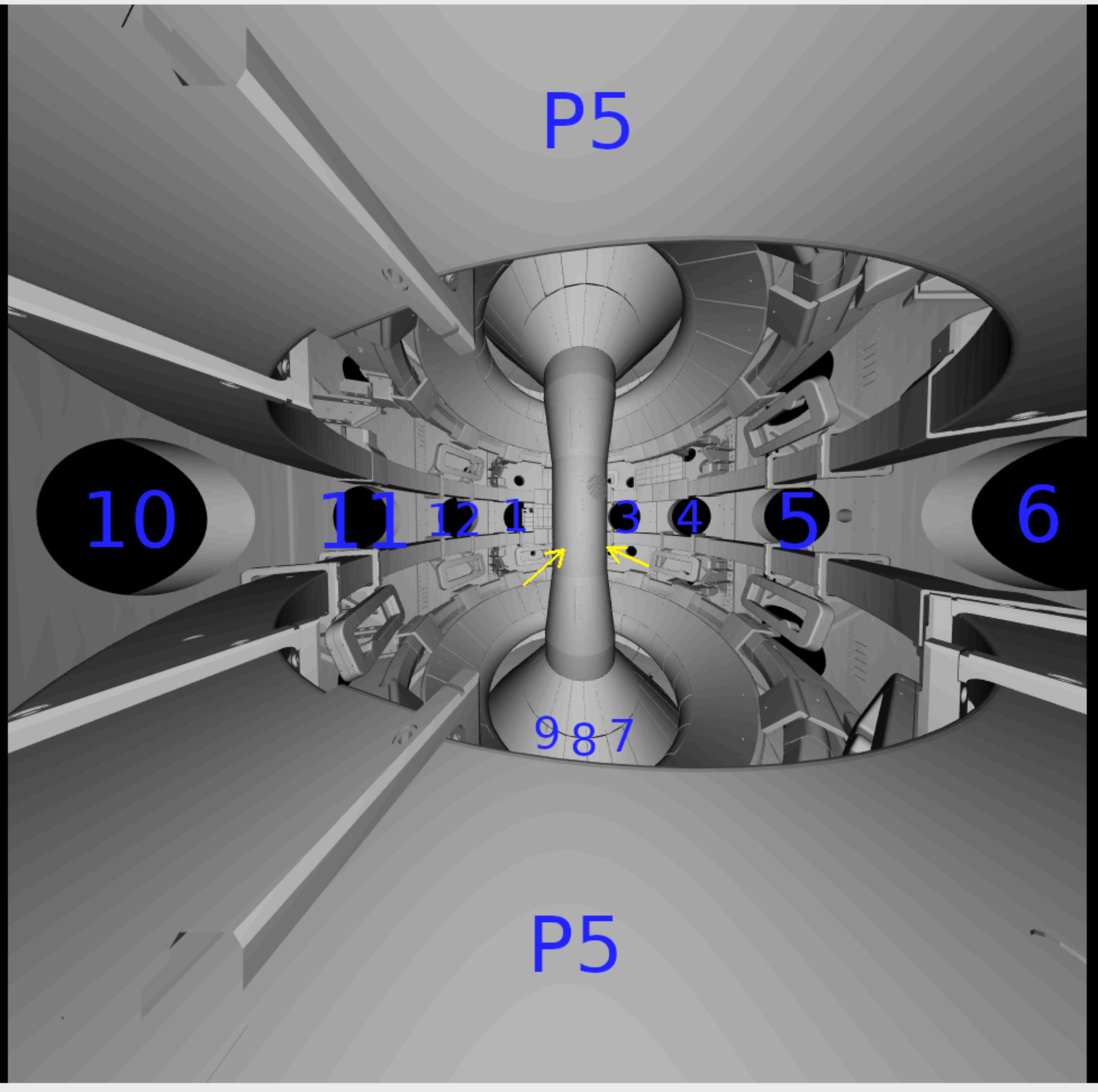

shot 45283
bin7>2c0
Time 100ms

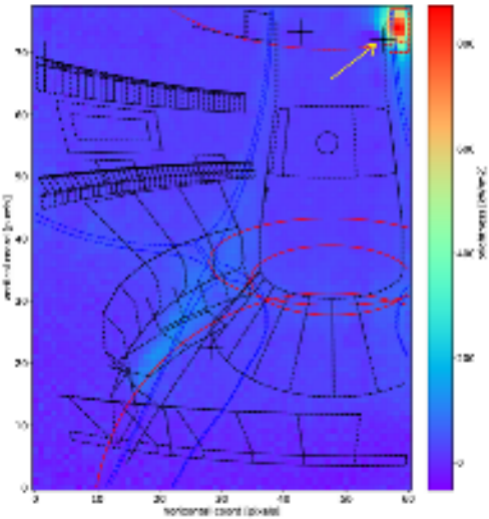

shot 45295
50 ms

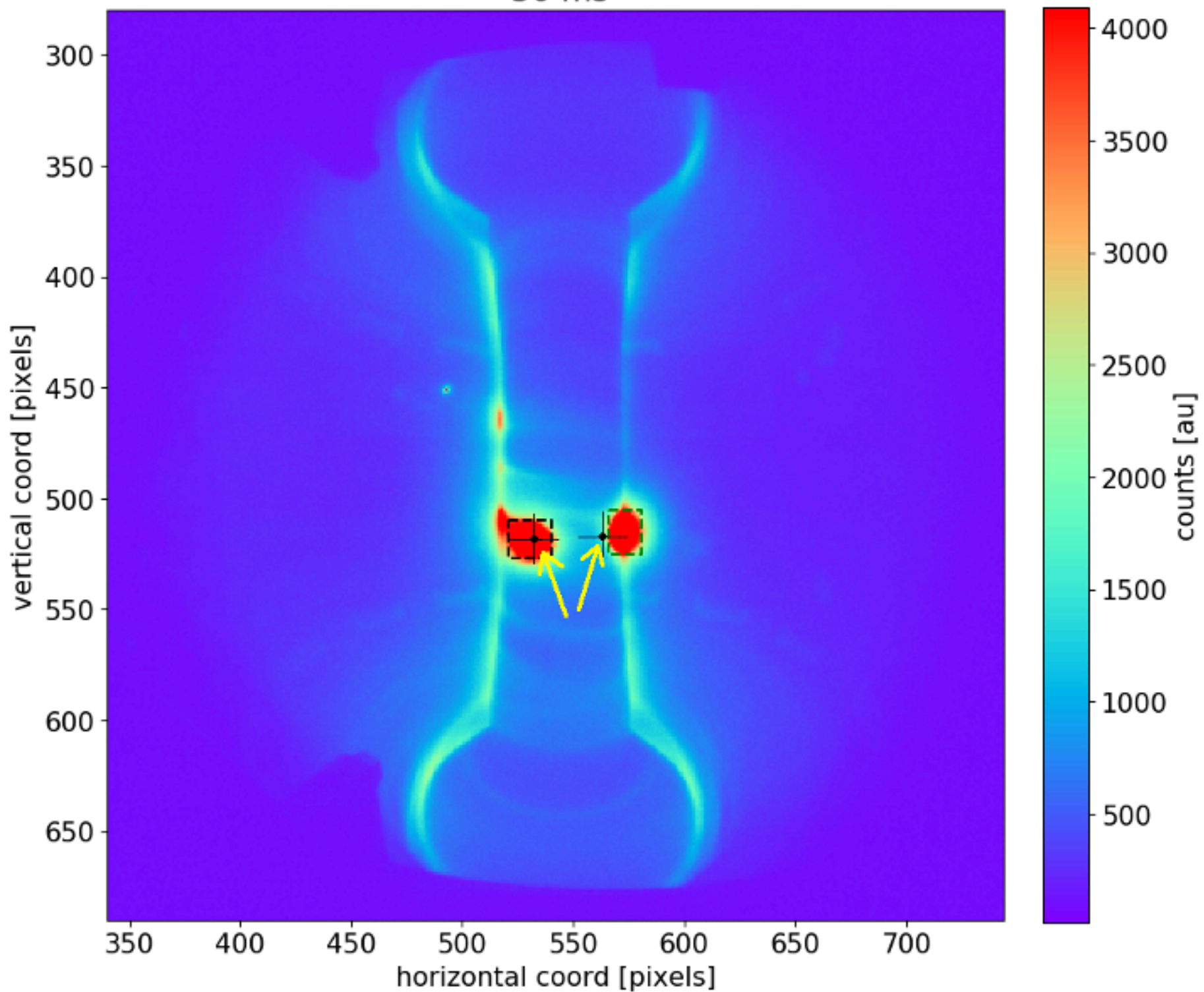

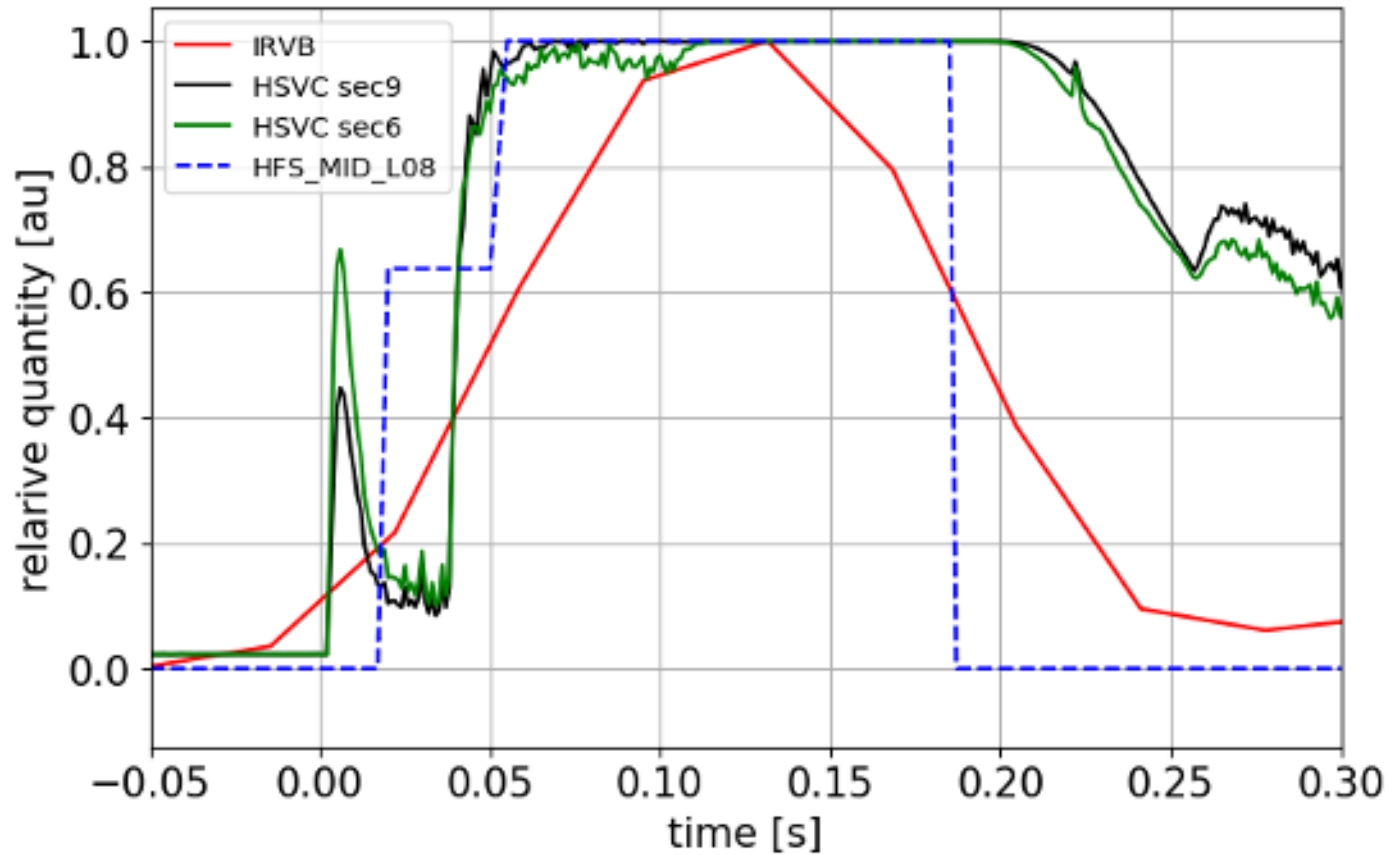

shot 45283
bin(7x2)c
Time 300ms

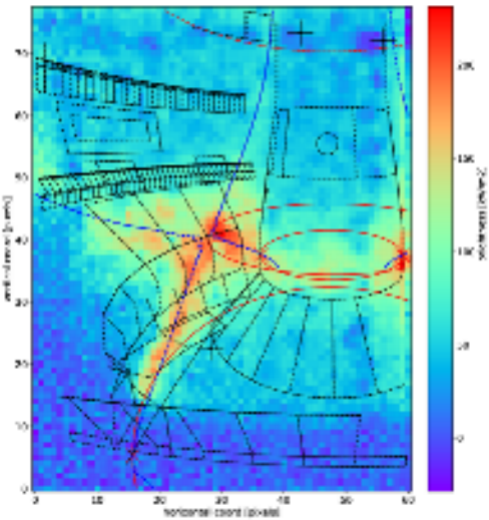

shot 45225
no binning
Time 802ms

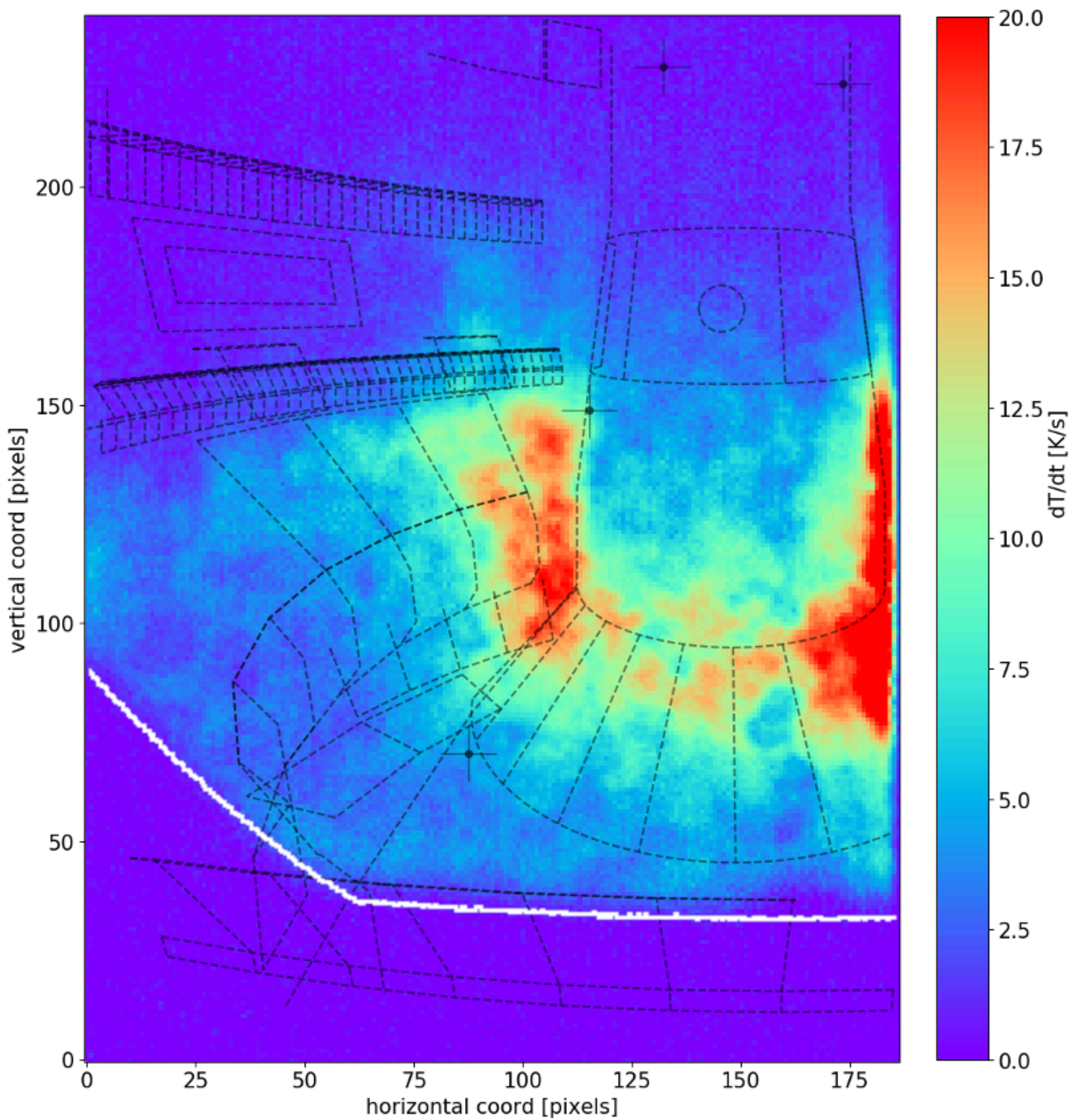

shot 45473
bin6x3x3
Time 386ms

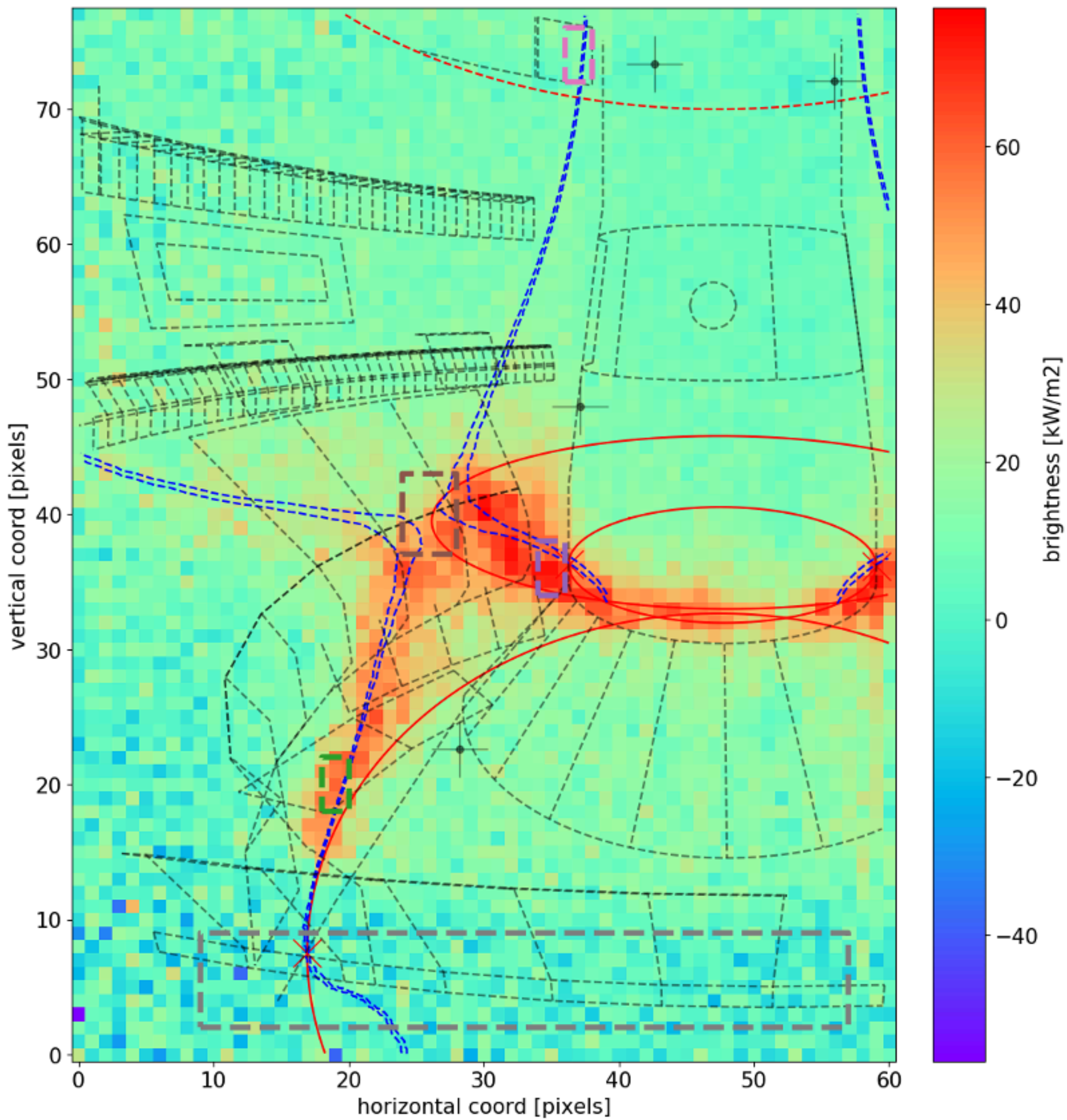

shot 45473
bin6x3x3
Time 511ms

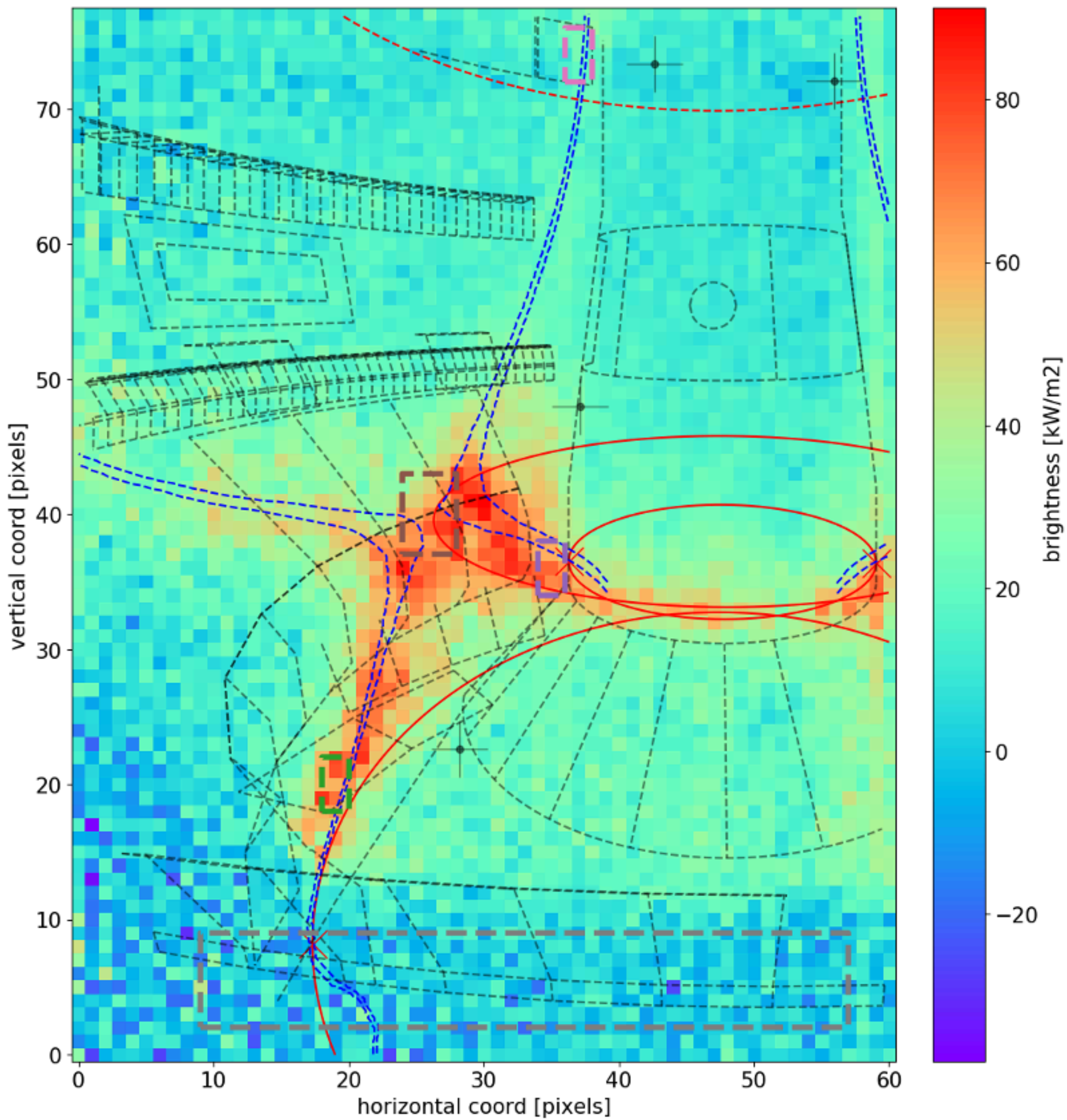

shot 45473
bin6x3x3
Time 605ms

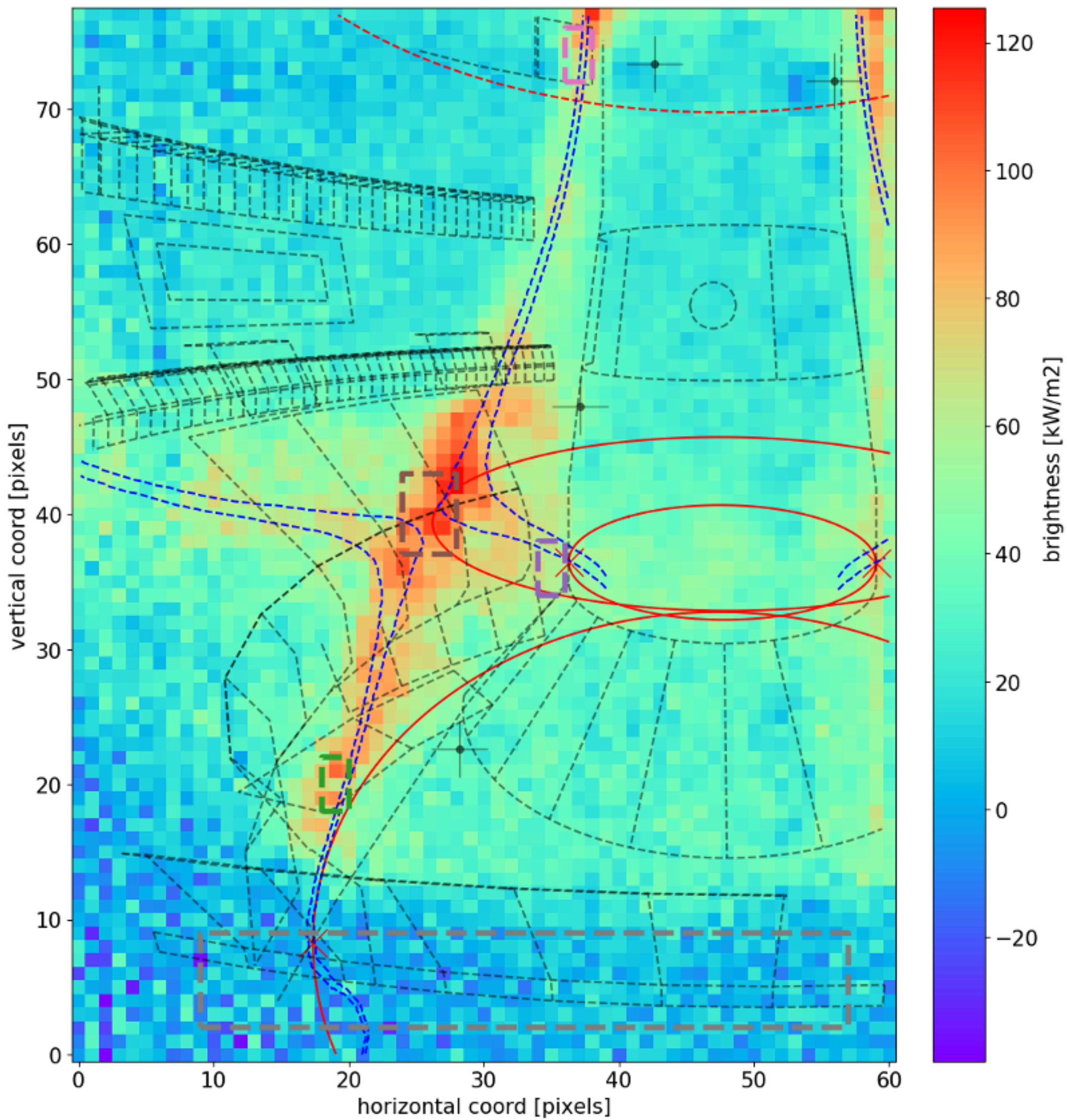

shot 45473
bin6x3x3
Time 699ms

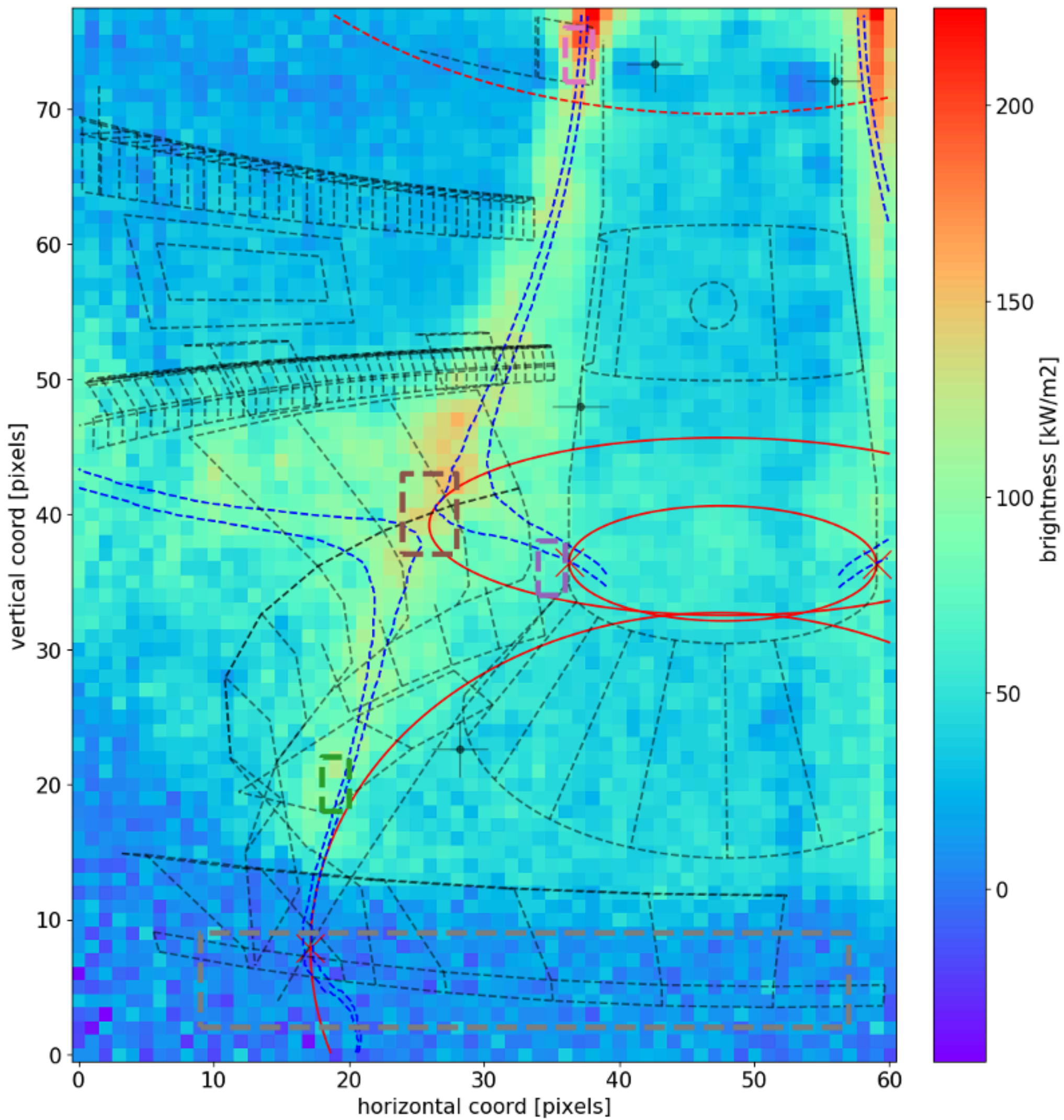

shot 45473
bin6x3x3
Time 762ms

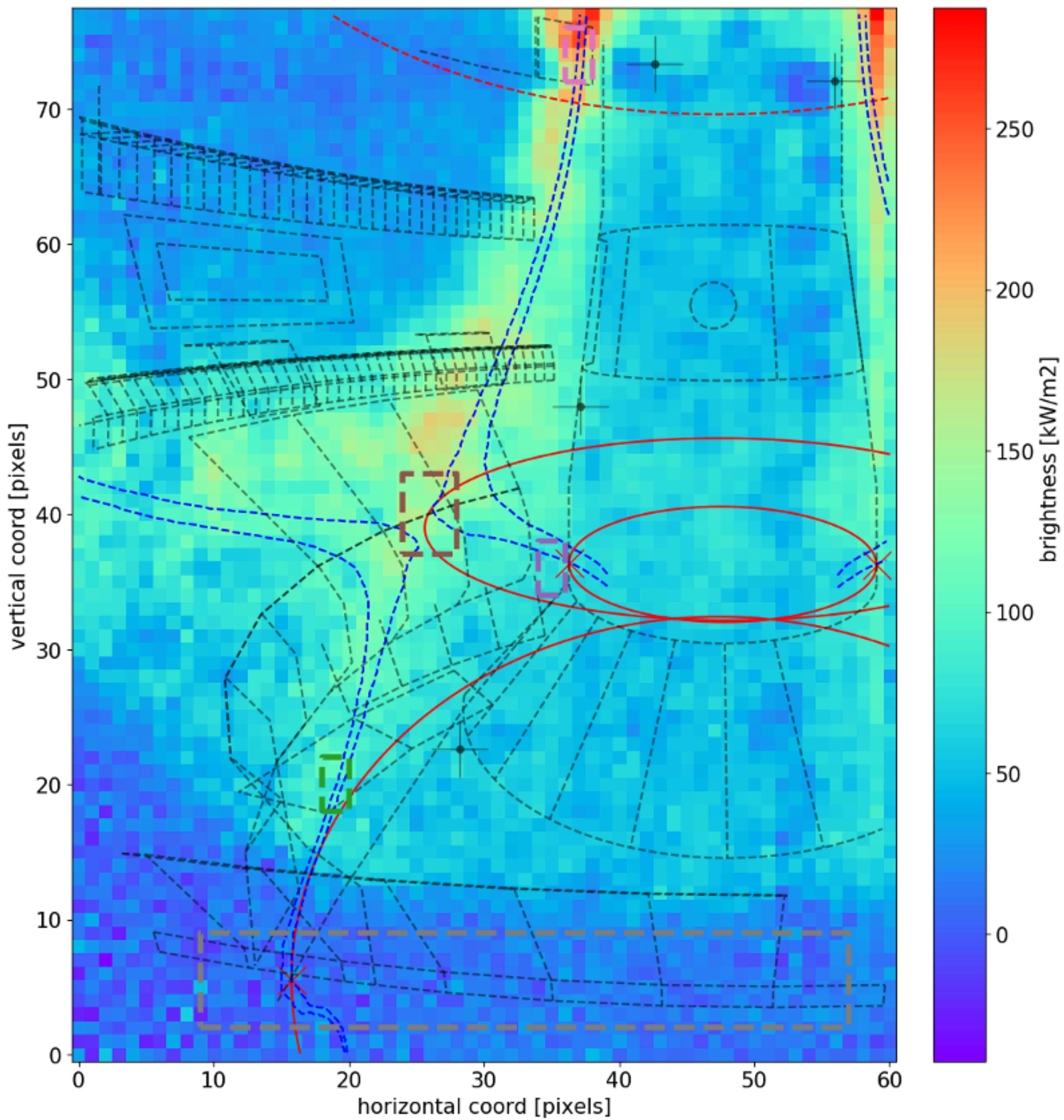

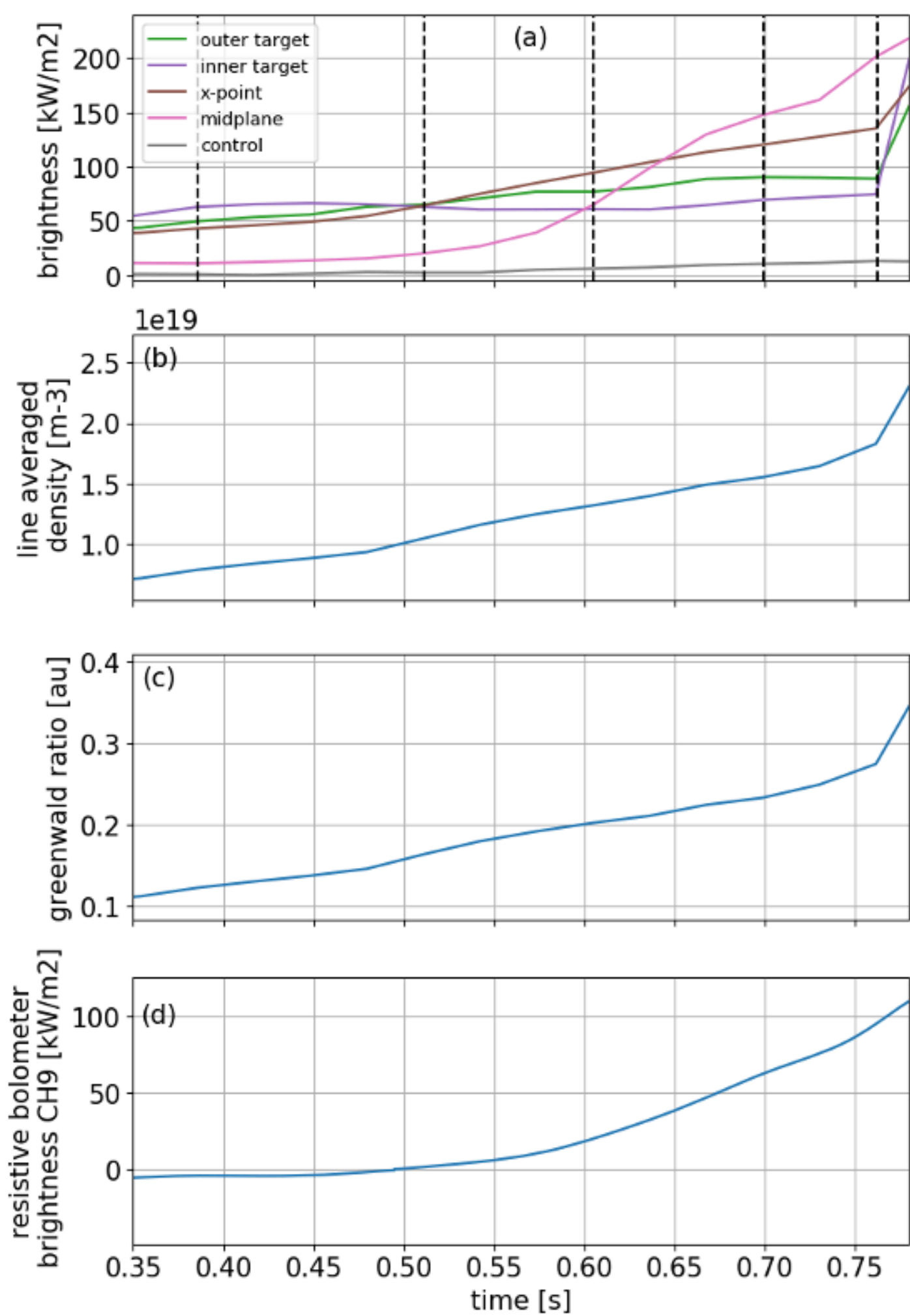

shot 45401
bin7x3x3
Time 315ms

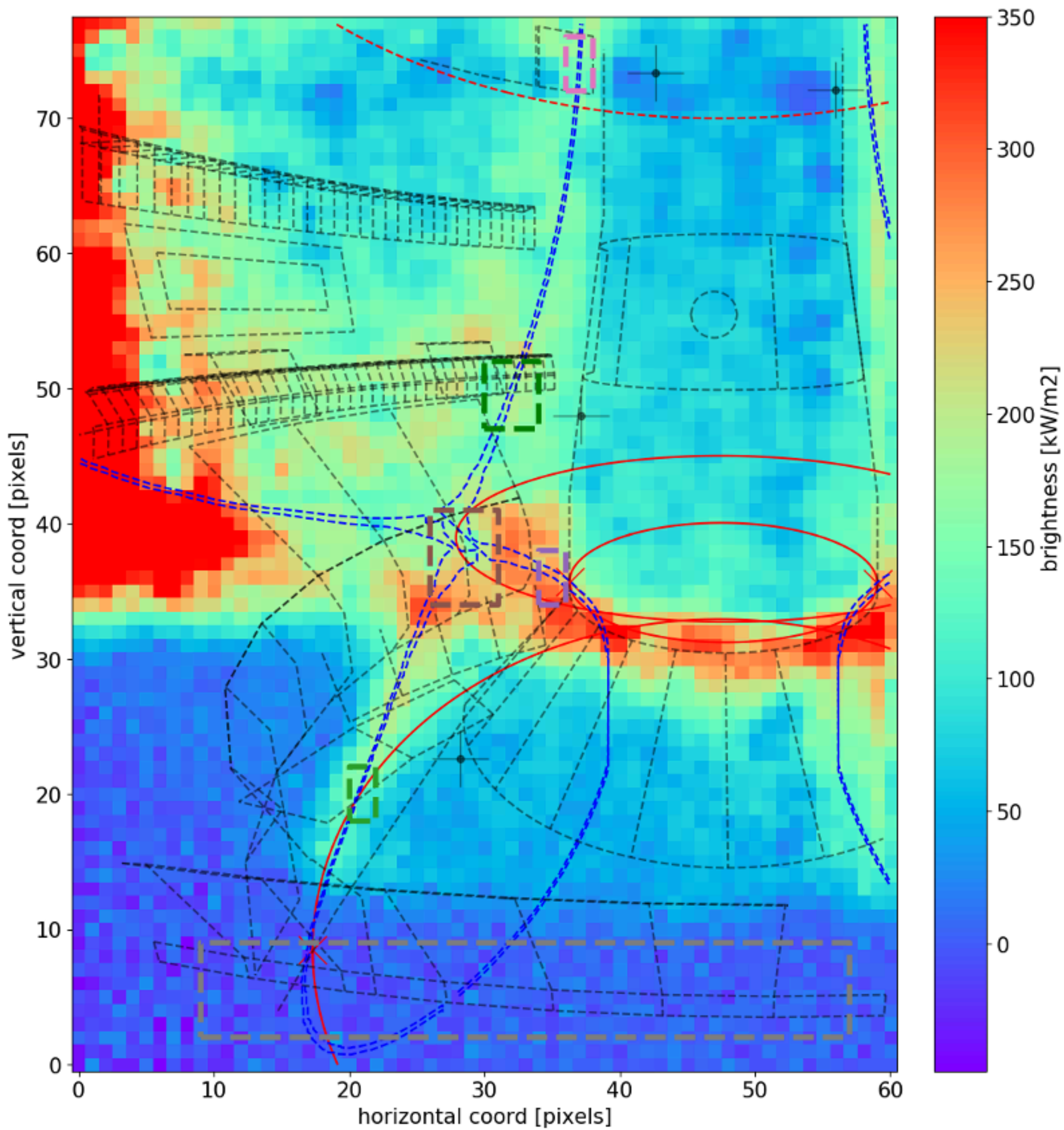

shot 45401
bin7x3x3
Time 717ms

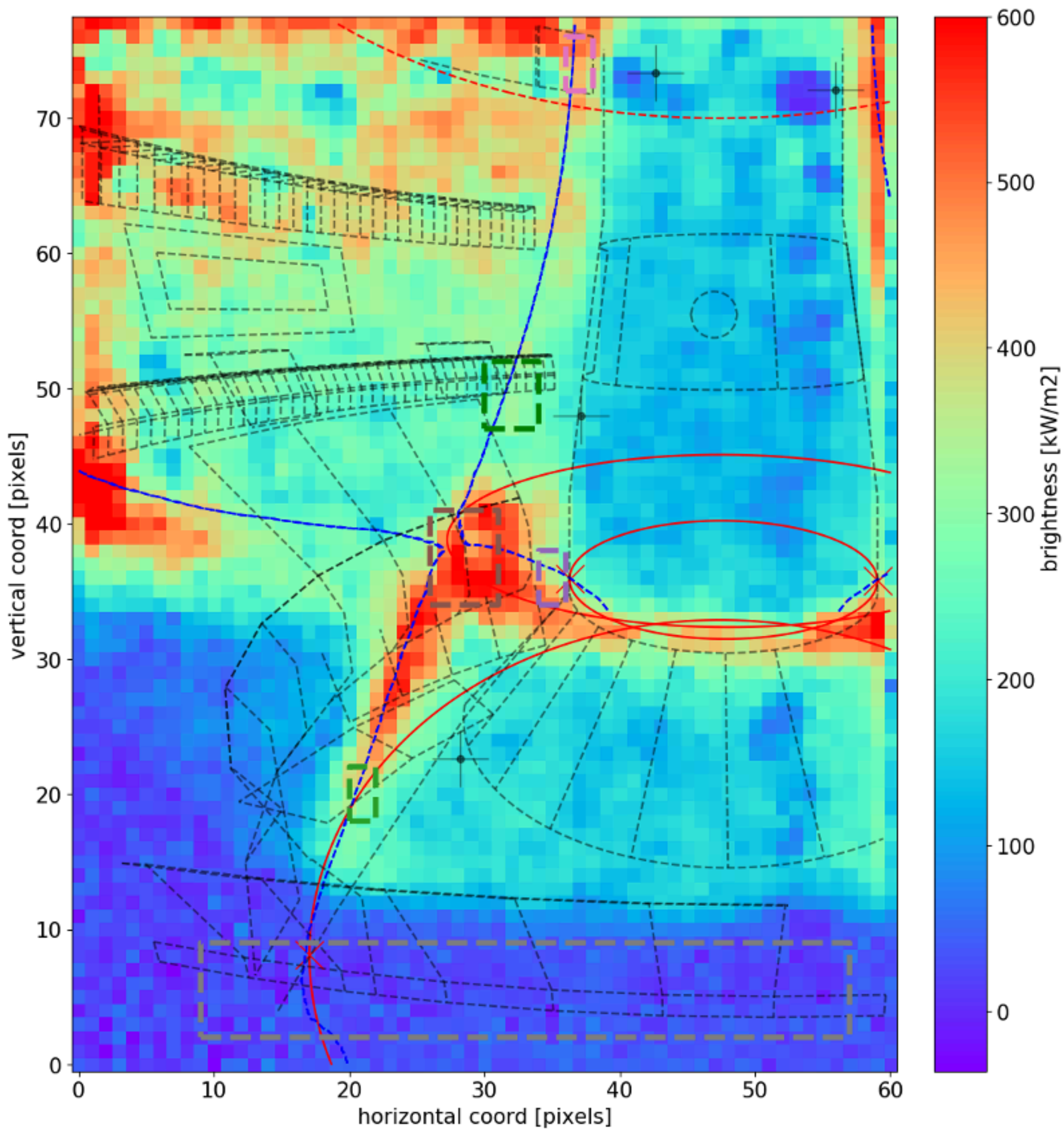

shot 45401
bin7x3x3
Time 826ms

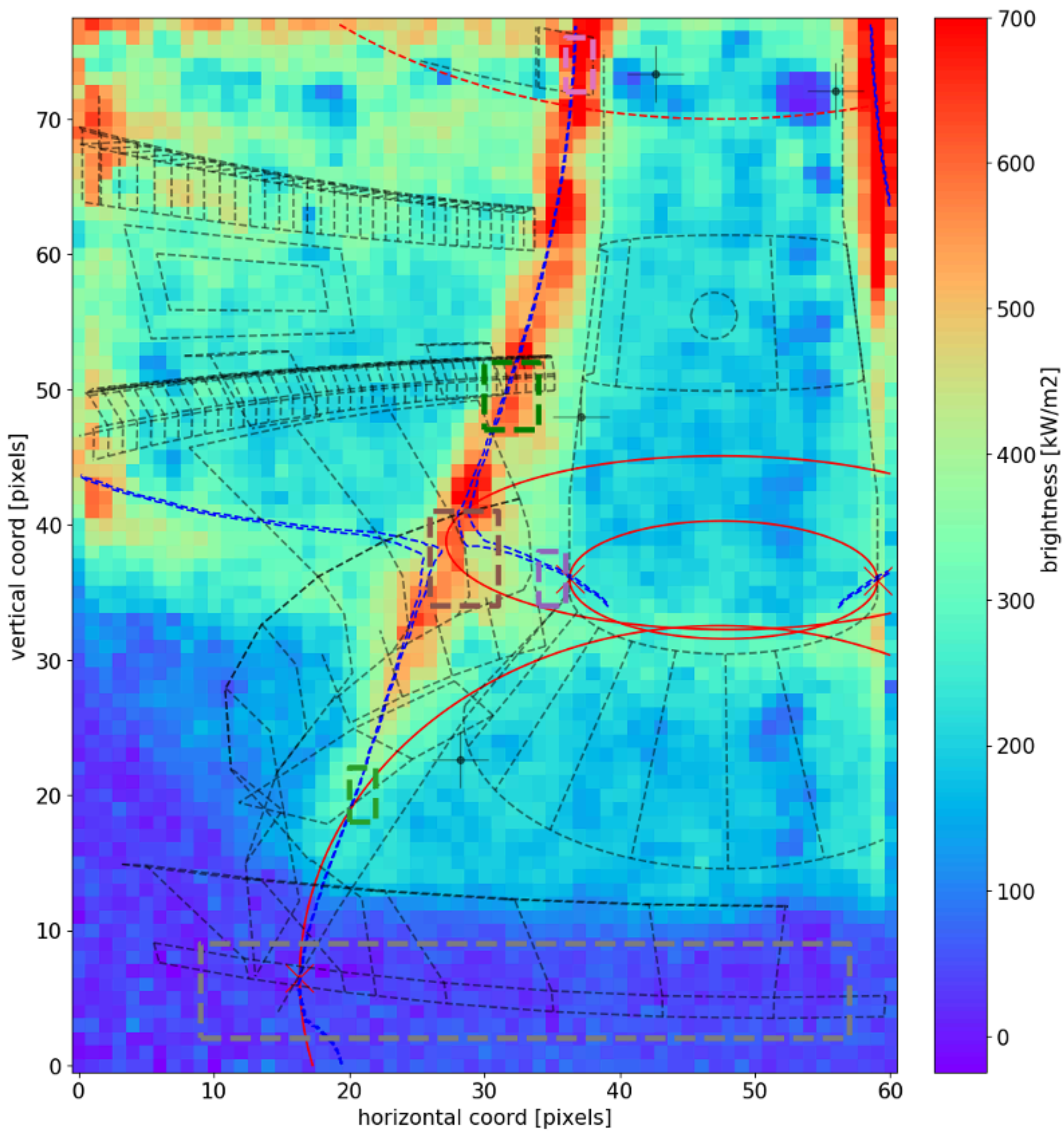

shot 45401
bin7x3x3
Time 1.01e+03ms

