

IER-423 Flattop Benchmark

CED-2

LA-UR-21-22953

**David Hayes, Theresa Cutler, Jeffrey Favorite, Joetta Goda,
Jesson Hutchinson, Robert Little, William Myers, Michael Rising**

March 2021

IER 423: Reevaluation of Flattop HEU Core Benchmark. CEDT Phase-2 Final Design

1. Objective

The final design for the Flattop HEU Core Benchmark is presented in this report. Physical measurements will be performed on Flattop components using modern instruments and techniques to define uncertainties necessary to meet contemporary ICSBEP standards.

2. Background

A preliminary re-evaluation (Ref. 1) of ICSBEP HMF-0028 (Flattop HEU Core) (Ref. 2) led to the development of IER-423 CED-1 (Ref. 3), wherein total relative uncertainties in k_{eff} were provided based on a new detailed model. The total relative uncertainties are presented in Table I (Ref. 1). The estimated uncertainty on the total uncertainty is +100%/-0%, given a lack of documented uncertainties on mass, dimensions, and densities of predominantly the natural uranium (NU) and highly enriched uranium (HEU) components.

Table I. Total Relative Uncertainty in k_{eff} (Preliminary)

Effect	$\sigma k/k_{eff}$
Mass and Volume Uncertainty of HEU Parts	± 0.00071
Mass and Volume Uncertainty of NU Parts	± 0.00137
HEU Isotopics	± 0.00018
Structural Material Mass Densities	± 0.00001
Gaps Between Reflector Parts	± 0.00025
Total	± 0.00157

3. Evaluation of Uncertainties

The largest uncertainty (by a factor of almost 2) was due to NU mass and volume uncertainty. An uncertainty of ± 0.03 inches in the outer radius of the NU reflectors, leads to a volume uncertainty of $\pm 1\%$. The volume uncertainty coupled with a mass uncertainty of $\pm 1\%$ results in a k_{eff} uncertainty of ± 0.00137 . The next largest uncertainty was due to HEU core mass and volume uncertainty. Favorite used an uncertainty of ± 0.003 inches in the radius of the HEU core, which led to a volume uncertainty of $\pm 0.4\%$. The volume uncertainty coupled with a mass uncertainty of $\pm 0.1\%$ results in a k_{eff} uncertainty of ± 0.00071 .

Modern measurement systems and techniques have been explored to resolve mass, volume, and density uncertainties. Accurate assessment of their uncertainties are as important as having accurate measurements of mass, dimensions, and densities. The uncertainties of the uncertainties reported in Ref. 1 were enormous because the underlying uncertainties were merely guesses.

Instruments to measure mass, dimensions, and density were selected based on minimizing uncertainties and ease of implementation in situ. Weighing the NU reflectors will require a crane scale. The MSI 4300 Port-A-Weigh Plus has an accuracy of +0.1% (one-sided uncertainty) of the applied load (Ref. 4). Dimensions are best obtained via coordinate measuring machine (CMM).

The Romer 8520-7 with RS6 Scanner provides a reverse engineering capability with an accuracy of ± 0.0026 mm (± 0.00102 inches) (Ref. 5). Accurate densities (on small actual or representative components) may be obtained using pycnometry. The Ultrapyc 5000 has an accuracy of $\pm 0.03\%$ (Ref. 6). These accuracies will be used to compute expected uncertainties in k_{eff} using sensitivity coefficients (Ref. 1) for mass and volume reproduced in Table II and Table III.

Table II. Relative Uncertainty in k_{eff} Due to Mass and Volume Uncertainty of NU Parts

$\sigma m/m$ → $\sigma V/V$ ↓	± 0	± 0.005	± 0.01	± 0.015
± 0.000	± 0.00000	± 0.00051	± 0.00103	± 0.00154
± 0.004	± 0.00034	± 0.00062	± 0.00108	± 0.00158
± 0.008	± 0.00069	± 0.00086	± 0.00124	± 0.00177
± 0.012	± 0.00103	± 0.00115	± 0.00146	± 0.00186
± 0.016	± 0.00138	± 0.00147	± 0.00172	± 0.00207
± 0.020	± 0.00172	± 0.00180	± 0.00201	± 0.00231

Table III. Relative Uncertainty in k_{eff} Due to Mass and Volume Uncertainty of HEU Parts

$\sigma m/m$ → $\sigma V/V$ ↓	± 0	± 0.0001	± 0.001
± 0.000	± 0.00000	± 0.00005	± 0.00053
± 0.004	± 0.00053	± 0.00053	± 0.00075
± 0.008	± 0.00106	± 0.00106	± 0.00118
± 0.012	± 0.00158	± 0.00158	± 0.00167
± 0.016	± 0.00211	± 0.00211	± 0.00218
± 0.020	± 0.00264	± 0.00264	± 0.00269

Using the uncertainties in Table II and Table III, new uncertainties were determined using the accuracy (± 0.026 mm (2σ)) of the RS6 3D Laser Scanner with Model 8525-7 Absolute Arm and the accuracy of the MSI-4300 Scale ($\pm 0.1\%$). If the uncertainty in the dimensions of the NU parts is actually ± 0.0015 in. (± 0.038 mm), then the volume uncertainty would be $\pm 0.05\%$. That coupled with a mass uncertainty of $\pm 0.1\%$ would reduce the corresponding k_{eff} uncertainty to ± 0.00013 . If the uncertainty in the radius of the HEU core is actually ± 0.0015 in., then the volume uncertainty would be $\pm 0.19\%$. That coupled with a mass uncertainty of $\pm 0.01\%$ (using conventional scales) would reduce the corresponding k_{eff} uncertainty to ± 0.00035 . Results are summarized in Table IV.

Table IV. Comparison of Uncertainties with and without Modern Measurements

Uncertainties in NU Components					
	Radius		Volume	Mass	k_{eff}
	[inches]	[mm]	[%]	[%]	
Previous Assumptions	±0.03	±0.762	±1	±1	±0.00136
New data	±0.0015	±0.038	±0.05	±0.1	±0.00013
Uncertainties in HEU Components					
	Radius		Volume	Mass	k_{eff}
	[inches]	[mm]	[%]	[%]	
Previous Assumptions	±0.003	±0.076	±0.4	±0.01	±0.00071
New data	±0.0015	±0.038	±0.19	±0.01	±0.00035

Modern, accurate measurements of the Flattop reflector and core dimensions and masses supplemented with representative densities will lead to a very detailed Flattop benchmark with a defensible uncertainty.

4. Context and Potential Impact

The evolution of relative uncertainties in k_{eff} is presented in Table V. Conducting modern measurements of masses, dimensions, and densities is expected to result in a six-fold decrease in the total relative uncertainty in k_{eff} for the Flattop HEU Benchmark.

Table V. Comparison of Existing and Preliminary Flattop HEU Benchmark Total Relative Uncertainty in k_{eff} .

Effect	HMF-028	IER-423 CED-1	IER-423 CED-2
	σ_k/k_{eff}	σ_k/k_{eff}	σ_k/k_{eff}
Mass and Volume Uncertainty of HEU Parts	±0.00160	±0.00071	±0.00035
Mass and Volume Uncertainty of NU Parts	-	±0.00137	±0.00013
HEU Isotopics	-	±0.00018	±0.00018
Structural Material Mass Densities	-	±0.00001	±0.00001
Gaps Between Reflector Parts	-	±0.00025	±0.00025
Total	±0.00300	±0.00157	±0.00048

Flattop has been used for many experiments at NCERC. This includes the DUFF experiment, IER-252 (Flattop radiation field in DAF), IER-253 (International Intercomparison Exercise for Nuclear Accident Dosimetry using Flattop), and many activation foil and fission chamber measurements (e.g., IER-281, IER-504). Detailed simulation comparisons (such as for the IRPHeP) will be possible for past and future experiments (e.g., IER-301, Plutonium Aging) with an accurate ICSBEP evaluation. Modern, accurate measurements of the Flattop reflector and core dimensions and masses supplemented with representative densities will lead to a very detailed

Flattop benchmark with a defensible uncertainty consistent with contemporary ICSBEP standards.

5. Conclusion

The objective of defining uncertainties for the Flattop HEU Benchmark that meet modern ICSBEP standards may be met utilizing instrumentation and techniques identified above. Final design for the Flattop HEU Benchmark has been established as the configuration preliminarily evaluated in Ref. 1 with updated physical measurements.

6. Cost Estimate

The cost estimate for executing the requisite measurements and documenting the benchmark are provided in Table VI.

Table VI. Cost Estimate

Activity	Estimated Cost
Measurement Tools Procurement	
○ Pycnometer	\$19,000
○ CMM	\$102,367
○ Training	\$7,500
○ Digital Crane Scale	\$4,169
Measurement Execution (Three weeks of NCERC operations to disassemble, measure, assemble, and measure excess.)	\$300,000
ICSBEP Evaluation	
○ Write-up/Revision	\$200,000
○ Presentation at ICSBEP	\$50,000

Note that the instrumentation above will be valuable to all experiments at NCERC.

7. References

1. J. A. Favorite, *Preliminary Flattop-25 Reevaluation Results*, LA-UR-15-29661, (2015).
2. R. W. Brewer, T. P. McLaughlin, and Virginia Dean, "Uranium-235 Sphere Reflected by Normal Uranium Using Flattop," *International Handbook of Evaluated Criticality Safety Benchmark Experiments*, HEU-MET-FAST-028, Revision 1, Nuclear Energy Agency, Organization for Economic Co-Operation and Development (September 2015).
3. J. A. Favorite, *et al*, *Reevaluation of Flattop HEU Core Benchmark. CEDT Phase-1 Preliminary Design*, LA-UR-16-21751, (2016).
4. MSI-4300 Port-A-Weigh Plus Digital Crane Scale Specifications, Page 2
5. Hexagon Absolute Arm Specifications, Page 30
6. Ultrapyc 5000 Specifications, Page 3



Los Alamos National Laboratory, an affirmative action/equal opportunity employer, is managed by Triad National Security, LLC, for the National Nuclear Security Administration of the U.S. Department of Energy under contract 89233218CNA000001.

MSI-4300 PORT-A-WEIGH PLUS

DIGITAL CRANE SCALE

The Port-A-Weigh Plus is world renowned for safe and reliable use in heavy-duty industrial crane scale applications. No other crane scale compares with the advanced features and benefits provided by the MSI-4300.

Port-A-Weigh Plus includes an extra large 1.6 inch (40 mm) alphanumeric LCD display with adjustable backlighting providing user-friendly visibility from a distance in day or night conditions. Full digital calibration and self-diagnostic circuitry ensure simple and cost-effective maintenance over a long and useful product life. All electronics are securely shock mounted in a robust NEMA 4/IP66 enclosure including dual O-ring sealing gaskets to ensure watertight integrity in washdown and marine applications. The Port-A-Weigh Plus is the ideal crane scale for all heavy-duty applications in nearly any industrial environment.



Specifications

Accuracy:	+ (0.1% +1 d) of applied load
Resolution:	3000 to 5000 d standard (up to 10,000 d available)
Enclosure:	NEMA 4 IP66, marine grade 356 alloy anodized cast aluminum
Top Lifting Eye, Shackle & Hook:	Crosby® or equal with 360° thrust-bearing swivel hook
Design Overload:	200% safe / 500% ultimate (except as noted)
Functions:	POWER, ZERO, NET/GROSS, TARE and programmable TEST/USER
Display:	Six-digit, 1.6 in (40 mm) LCD (upper) Eight-digit, 0.8 in (20 mm) LCD (lower) with adjustable display contrast
Displayable Units:	Pounds, kilograms, tons, and metric tons selectable
Power:	12 volt rechargeable battery. 115/230VAC battery charger included
Operating Time:	300 hours with typical use
Operating Temperature:	5°F to 122°F (-15°C to 50°C)
Filtering:	OFF, LO, Medium and HI selectable
Approvals:	NTEPC 92-176-5,0000 lb (2,500 kg) Measurement Canada AM-4984

Options and Accessories

- NTEP Certified (contact factory for current USA and International approvals)
- Universal direct power supply: 85-265VAC, 47-440 Hz/130-300VDC
- D-Cell alkaline battery power
- Substitute shackle for bottom swivel hook (for possible headroom loss reduction)
- Oversized top lifting eye or shackle (for oversized crane hook interface)
- Oversized bottom swivel hook
- Low headroom adapter (for in-block installation)
- Audible alarm
- Marine/Fishing configuration (contact factory for further information)

Specifications and Dimensions

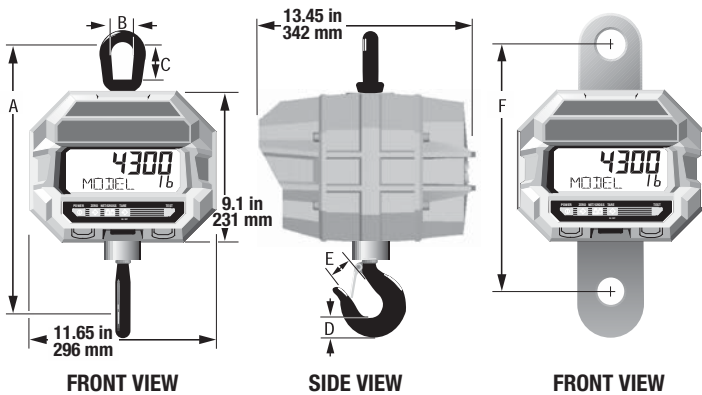

Note: 50/70/100,000 lb models come standard with top shackle and bottom swivel hook.

Capacity	Resolution**	A*	B*	C*	D*	E*	F	Hook	Eye Nut or Shackle	Approx. Shipping Weight
500 lb 250 kg	0.2 lb 0.1 kg	18.3 in 465 mm	2.25 in 57.1 mm	3.06 in 77.7 mm	1.44 in 37.0 mm	1.41 in 36.0 mm	—	5 ton alloy swivel	CR #7 eye nut	53 lb 24 kg
2,000 lb 1,000 kg	1 lb 0.5 kg	18.3 in 465 mm	2.25 in 57.1 mm	3.06 in 77.7 mm	1.44 in 37.0 mm	1.41 in 36.0 mm	—	5 ton alloy swivel	CR #7 eye nut	53 lb 24 kg
5,000 lb 2,500 kg	1 lb 0.5 kg	20.5 in 521 mm	2.50 in 64.0 mm	3.50 in 89.0 mm	1.81 in 46.0 mm	1.69 in 42.9 mm	—	7 ton alloy swivel	CR #8 eye nut	62 lb 28 kg
10,000 lb 5,000 kg	2 lb 1 kg	20.5 in 521 mm	2.50 in 64.0 mm	3.50 in 89.0 mm	1.81 in 46.0 mm	1.69 in 42.9 mm	—	7 ton alloy swivel	CR #8 eye nut	62 lb 28 kg
20,000 lb 10,000 kg	5 lb 2 kg	28.5 in 724 mm	4.00 in 101.6 mm	6.25 in 159 mm	2.62 in 66.5 mm	2.41 in 61.2 mm	—	15 ton alloy swivel	CR #11 eye nut	105 lb 47 kg
30,000 lb 15,000 kg	10 lb 5 kg	30.0 in 762 mm	4.00 in 101.6 mm	6.25 in 159 mm	3.00 in 76.2 mm	3.19 in 81.0 mm	—	22 ton alloy swivel	CR #11 eye nut	125 lb 55 kg
50,000 lb 25,000 kg***	10 lb 5 kg	41.0 in 1041 mm	5.00 in 127 mm	6.00 in 152 mm	3.62 in 92.0 mm	3.63 in 92.0 mm	15.0 in 381 mm	30 ton alloy swivel	CR 25 ton shackle # 2130	235 lb 106 kg
70,000 lb**** 35,000 kg****	20 lb 10 kg	43.2 in 1097 mm	5.00 in 127 mm	6.00 in 152 mm	4.56 in 116 mm	3.75 in 95.0 mm	15.0 in 381 mm	37 ton alloy swivel	CR 40 ton shackle # 2140	270 lb 121 kg
100,000 lb***** 50,000 kg*****	20 lb 10 kg	52.1 in 1324 mm	5.75 in 146 mm	6.65 in 169 mm	5.06 in 129 mm	4.25 in 108 mm	16.25 in 413 mm	CR 45 ton S1 swivel	CR 55 ton shackle # 2140	420 lb 189 kg

CR = Crosby® or equivalent (Crosby is a registered trademark of The Crosby Group, LLC.)

* These dimensions also apply to 50/70/100,000 lb models with hook and shackle

** Resolution subject to change for NTEP Certified and OIML units

*** Ultimate overload: 490% of kg capacity

**** Ultimate overload: 475% of lb capacity / 430% of kg capacity

***** Ultimate overload: 450% of kg capacity

Your Rice Lake Weighing Systems distributor is:

RICE LAKE
WEIGHING SYSTEMS

230 W. Coleman St. • Rice Lake, WI 54868 • USA
TEL: 715-234-9171 • FAX: 715-234-6967 • www.ricelake.com

An ISO 9001 registered company © 2014 Rice Lake Weighing Systems PN 154315 10/14
Specifications subject to change without notice.

Absolute Arm specifications

Absolute Arm 7-Axis accuracy and size specification

	Model	E _{UNI} ¹	P _{SIZE} ²	L _{DIA} ³	P _{FORM} ⁴	RS6 SSA ⁵	RS5 SSA ⁵	RS-SQUARED SSA ⁵	Weight	Max. reach
83 series	8320-7	0.043 mm	0.016 mm	0.054 mm	0.033 mm	0.059 mm	0.062 mm	NA	8.8 kg	2.48 m
	8325-7	0.048 mm	0.023 mm	0.060 mm	0.043 mm	0.065 mm	0.068 mm	0.164 mm	9.1 kg	2.98 m
	8330-7	0.078 mm	0.034 mm	0.090 mm	0.058 mm	0.082 mm	0.092 mm	0.204 mm	9.4 kg	3.48 m
	8335-7	0.092 mm	0.042 mm	0.115 mm	0.067 mm	0.099 mm	0.105 mm	0.242 mm	9.7 kg	3.98 m
	8340-7	0.114 mm	0.051 mm	0.140 mm	0.084 mm	0.118 mm	0.122 mm	0.283 mm	10.0 kg	4.48 m
	8345-7	0.158 mm	0.078 mm	0.168 mm	0.106 mm	0.163 mm	0.172 mm	0.338 mm	10.3 kg	4.98 m
85 series	8520-7	0.029 mm	0.010 mm	0.038 mm	0.021 mm	0.041 mm	0.045 mm	NA	9.0 kg	2.48 m
	8525-7	0.031 mm	0.012 mm	0.048 mm	0.025 mm	0.047 mm	0.048 mm	0.138 mm	9.3 kg	2.98 m
	8530-7	0.057 mm	0.020 mm	0.083 mm	0.038 mm	0.064 mm	0.066 mm	0.168 mm	9.6 kg	3.48 m
	8535-7	0.069 mm	0.024 mm	0.099 mm	0.045 mm	0.078 mm	0.080 mm	0.196 mm	9.9 kg	3.98 m
	8540-7	0.084 mm	0.030 mm	0.120 mm	0.050 mm	0.089 mm	0.091 mm	0.228 mm	10.2 kg	4.48 m
	8545-7	0.113 mm	0.048 mm	0.140 mm	0.065 mm	0.141 mm	0.148 mm	0.271 mm	10.5 kg	4.98 m
87 series	8725-7	0.029 mm	0.011 mm	0.044 mm	0.023 mm	0.043 mm	0.044 mm	0.123 mm	9.3 kg	2.98 m
	8730-7	0.053 mm	0.018 mm	0.076 mm	0.035 mm	0.056 mm	0.058 mm	0.148 mm	9.6 kg	3.48 m
	8735-7	0.064 mm	0.022 mm	0.092 mm	0.041 mm	0.068 mm	0.071 mm	0.173 mm	9.9 kg	3.98 m
	8740-7	0.078 mm	0.028 mm	0.110 mm	0.046 mm	0.080 mm	0.082 mm	0.198 mm	10.2 kg	4.48 m
	8745-7	0.104 mm	0.044 mm	0.125 mm	0.060 mm	0.121 mm	0.127 mm	0.222 mm	10.5 kg	4.98 m

3D scanner specifications

	RS6	RS5	RS-SQUARED	HP-L-8.9
Scanner type	Blue laser line scanner	Red laser line scanner	Structured light scanner	Red laser line scanner
Accuracy	0.026 mm (2σ)	0.028 mm (2σ)	0.06 mm (2σ)	0.04 mm (2σ)
Point acquisition rate	up to 1.2 million points/s	752 000 points/s	4 000 000 points/s (grid of raw points, no interpolation available)	45 000 points/s
Points per frame	max. 4000	max. 7520	1 million	750
Frame rate	max. 300 Hz	max. 100 Hz	max. 4 Hz	60 Hz
Line width (mid)	150 mm	115 mm	-	80 mm
Frame size (at mid-range)	-	-	300 mm x 300 mm	-
Standoff	165 ± 50 mm	165 ± 50 mm	300 ± 50 mm	135 ± 45 mm
Minimum point spacing	0.027 mm	0.011 mm	0.21 mm	0.08 mm
System scanning certification	yes	yes	yes	no
Laser class	2	2M	2	2
Operating temperature	5–40°C	5–40°C	5–40°C	5–40°C
Weight	0.4 kg	0.4 kg	1.4 kg	0.32 kg

Industry solutions

Gas pycnometry is used extensively for determining the true density of porous solids. The Ultrapyc series complies with many ASTM, ISO, MIPF, and JIS standard test methods used across a wide variety of industries.



Powder coatings and dried film coatings The crystallinity of plastics and the true density of dry pigments are monitored by gas pycnometry to better understand the mechanical behavior of these materials. In addition, gas pycnometry can help determine the volatile organic content within dried films in order to assess the level of curing.



Cements The true density of cement is used for the accurate calculation of powder characteristics. Measured after setup time, the insights gained are important for formation and stability determination.



Mining and oil exploration Gas pycnometry is the primary technique used to quickly assess the composition of the solids used in drilling fluids.



Polymers and foams Gas pycnometry is widely used to characterize the relative amounts of crystalline and amorphous phases within polymer materials. This technique is also used to assess the open cell content of foam materials to predict their performance as insulators or as sound- or collision dampening materials.



Pharmaceuticals The true density of active and excipient materials is used to determine the composition for both development and process control purposes.



Ceramics and catalysts Density values are used in the development, manufacturing, and troubleshooting of refractory materials to confirm that the desired crystal phase is present and closed porosity is absent.



Metallurgy The true density of complex metal shapes formed by powder metallurgy is used to track the purity of raw materials or the presence of open or closed pores throughout processing.

Specifications

	Ultrapyc 3000	Ultrapyc 5000	Ultrapyc 5000 Foam	Ultrapyc 5000 Micro
	The base model	Includes built-in temperature control and PowderProtect mode	Includes built-in temperature control, PowderProtect mode, and foam mode	Includes built-in temperature control and PowderProtect mode
Large cell: 135 cm ³		Accuracy: 0.02 % Repeatability: 0.01 %		
Medium cell: 50 cm ³		Accuracy: 0.02 % Repeatability: 0.01 %		
Small cell: 10 cm ³		Accuracy: 0.03 % Repeatability: 0.015 %		
Micro cell: 4.5 cm ³				Accuracy: 0.10 % Repeatability: 0.05 %
Meso cell: 1.8 cm ³				Accuracy: 0.30 % Repeatability: 0.15 %
Nano cell: 0.25 cm ³				Accuracy: 1.00 % Repeatability: 0.50 %
Preparation modes	Flow, pulse	Flow, pulse, vacuum		
Transducer accuracy	Better than 0.1 %			
Pressure reading resolution	Digital pressure display resolution of 0.0001 psi			
Connections	4 USB ports			
Instrument dimensions				
Weight	10 kg			
W x D x H	27 cm x 48 cm x 25 cm			
Built-in temperature range	15 °C to 50 °C with stability better than ±0.05 °C			
Available connectivity to any balance using RS232 communication Results available on screen, via a printer, or electronically in text and pdf formats All units calibrated at the factory using NIST-traceable spheres A pressurized gas source up to 20 psi and a standard power outlet are required for operation.				
Accessories				
	Micro cell option		Non-elutriating cells	
Selected international standards	ASTM B923-10	Metal Powders	ASTM D5550-14	Soils
	ASTM C110-15	Cements	ASTM D5965-02 (2013)	Coatings
	ASTM C2604-02 (2012)	Refractories	ASTM D6093-97 (2011)	Pigments
	ASTM D2638-10	Carbon	ASTM D6226-15	Rigid Foams
	ASTM D4892-14	Carbon	USP 699	Pharmaceuticals