

Induced Fracture Geometry in Layered Media under Mixed Mode I and III Loading Conditions

Liyang Jiang, Hongkyu Yoon, Antonio Bobet, Laura J. Pyrak-Nolte

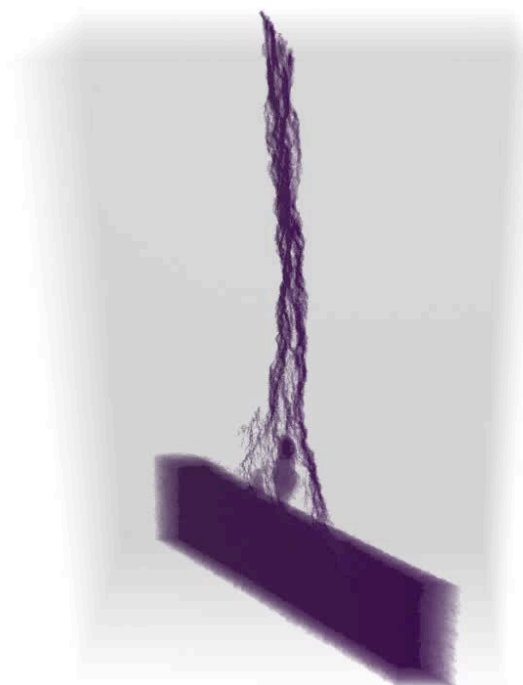

PURDUE
UNIVERSITY®

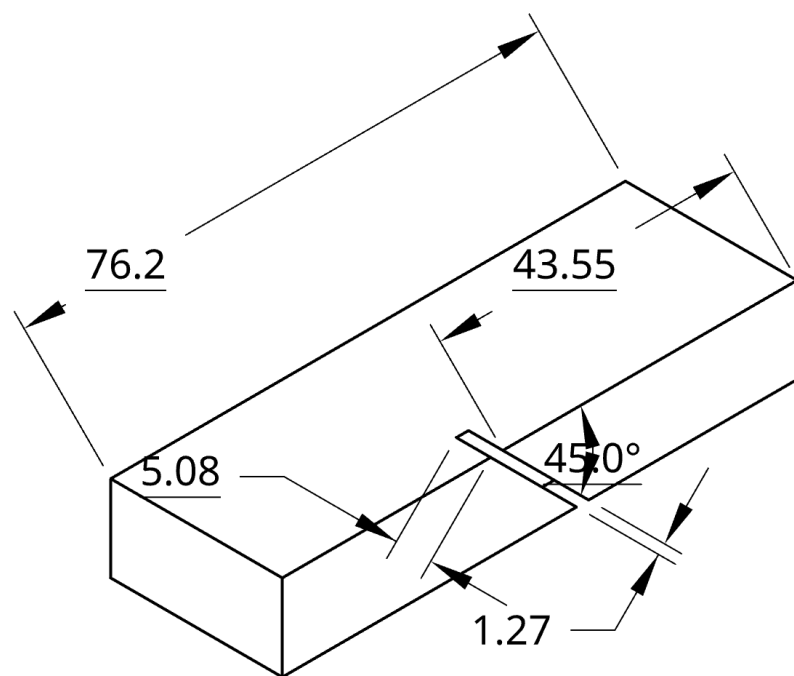

AGU FALL MEETING
New Orleans, LA & Online Everywhere
13-17 December 2021

Mixed Mode I and III Loading in Three Point Bending (3PB) Tests

Mode I & III (Mixed Mode)
Off Center Notch - Angle

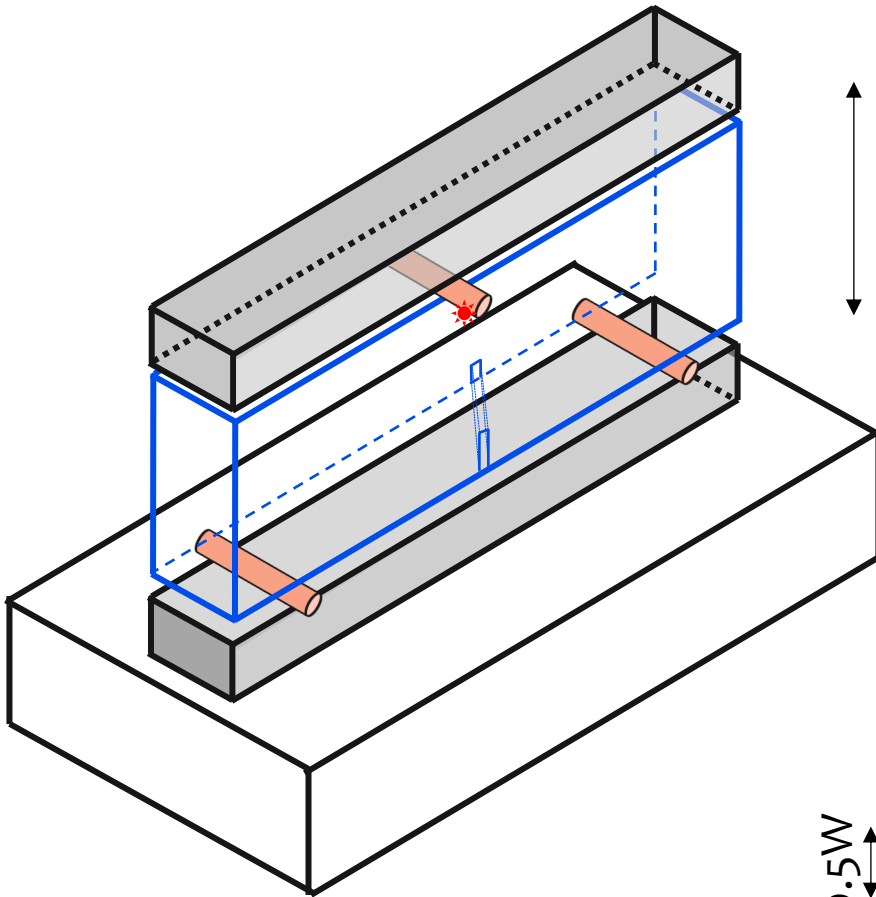

Front View

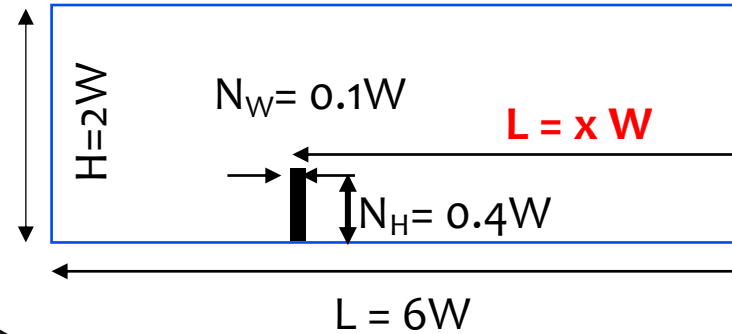

Back View

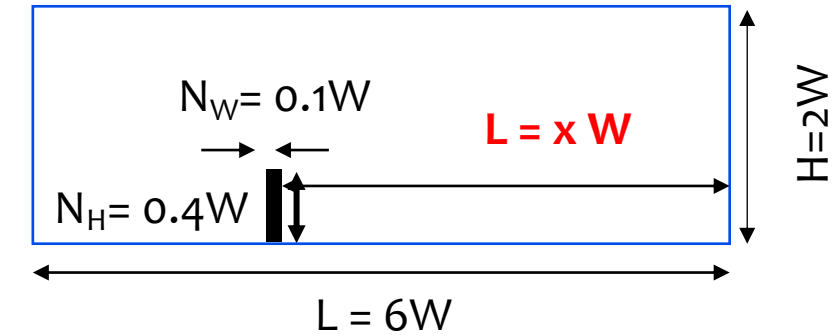

Where x depends on θ

Top View

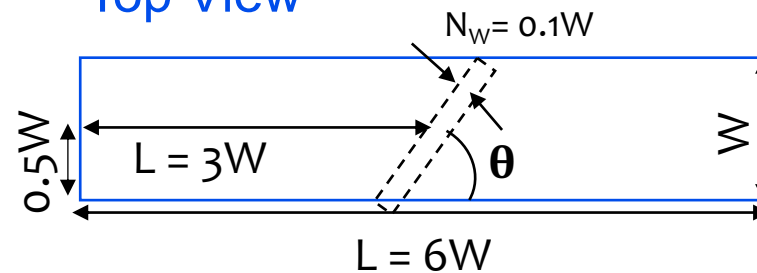

Side View

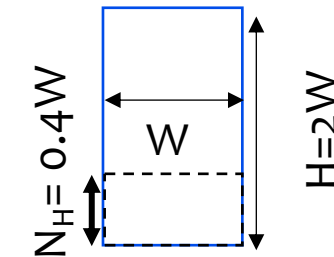

$W = 12.7 \text{ mm}$
 $H = 25.4 \text{ mm}$
 $L = 76.2 \text{ mm}$

Notch is rotated about center with an angle, $\theta = 20^\circ, 30^\circ, 45^\circ, 60^\circ$



Orientation in the Printing Bed

Printing Directions for Samples

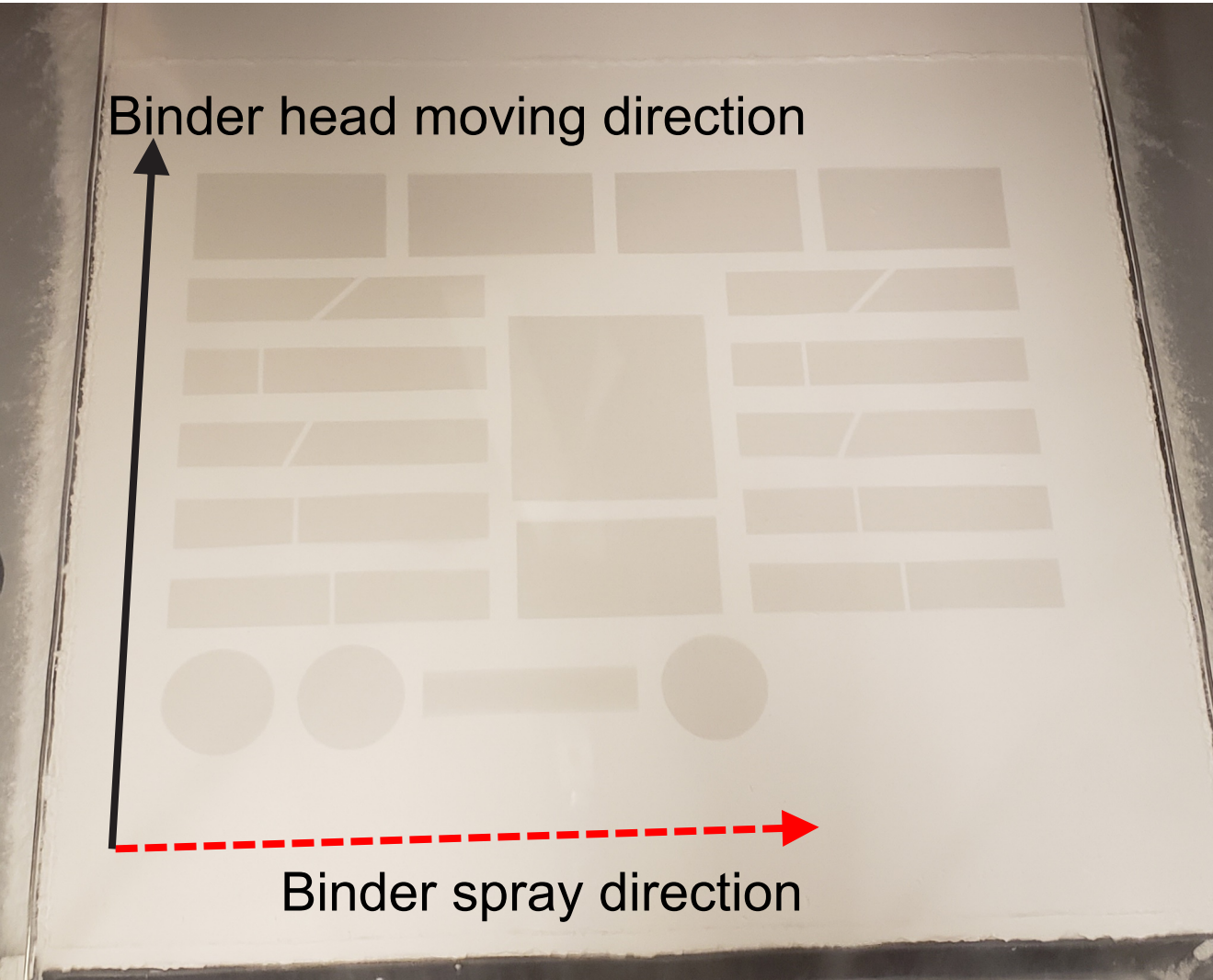

Samples after Printing



Sample Printing Design

Divider

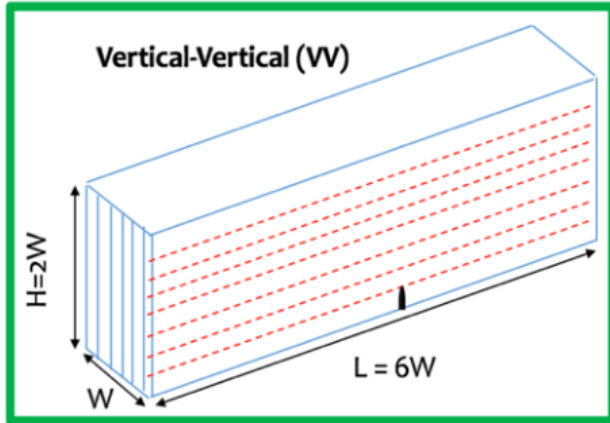

Short-Transverse

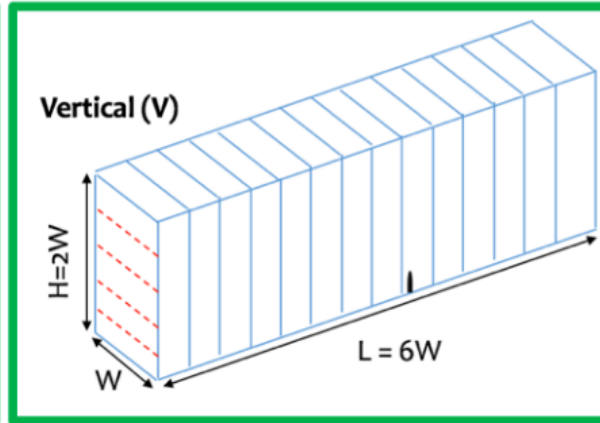

Arrester

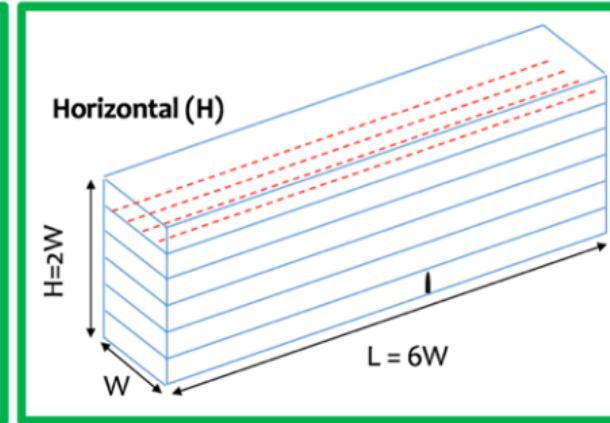

Divider

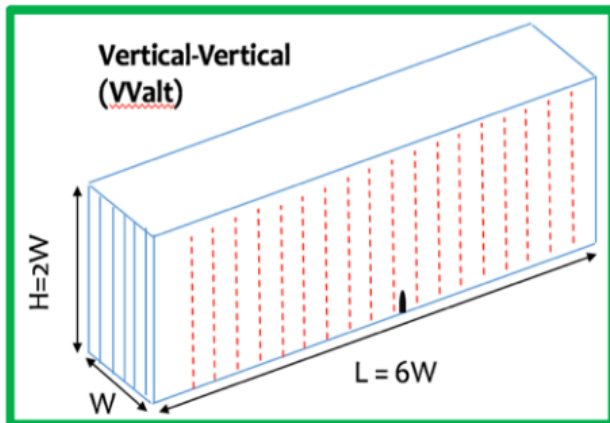

Short-Transverse

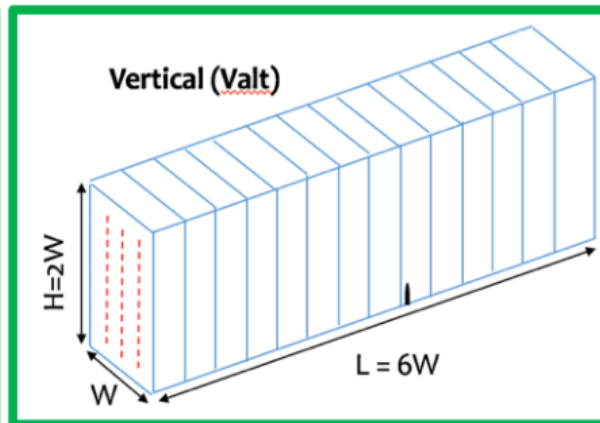

Arrester

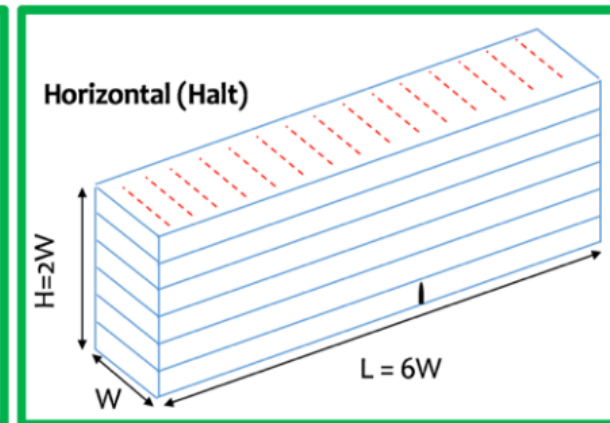

orientation of the bassanite layers (blue lines)
orientation of the gypsum texture (red lines)

Three Point Bending (3PB) Tests

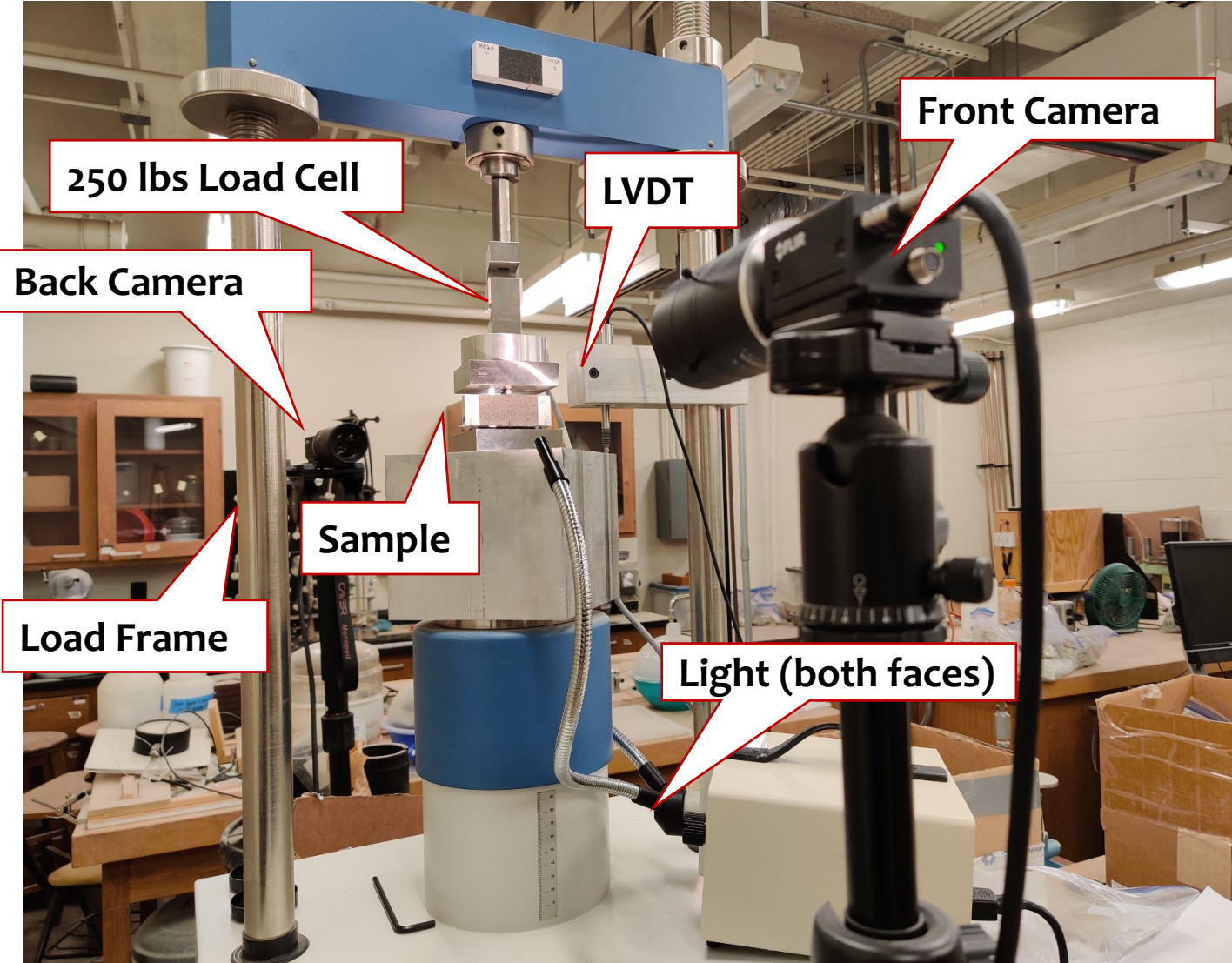

Experimental Setup

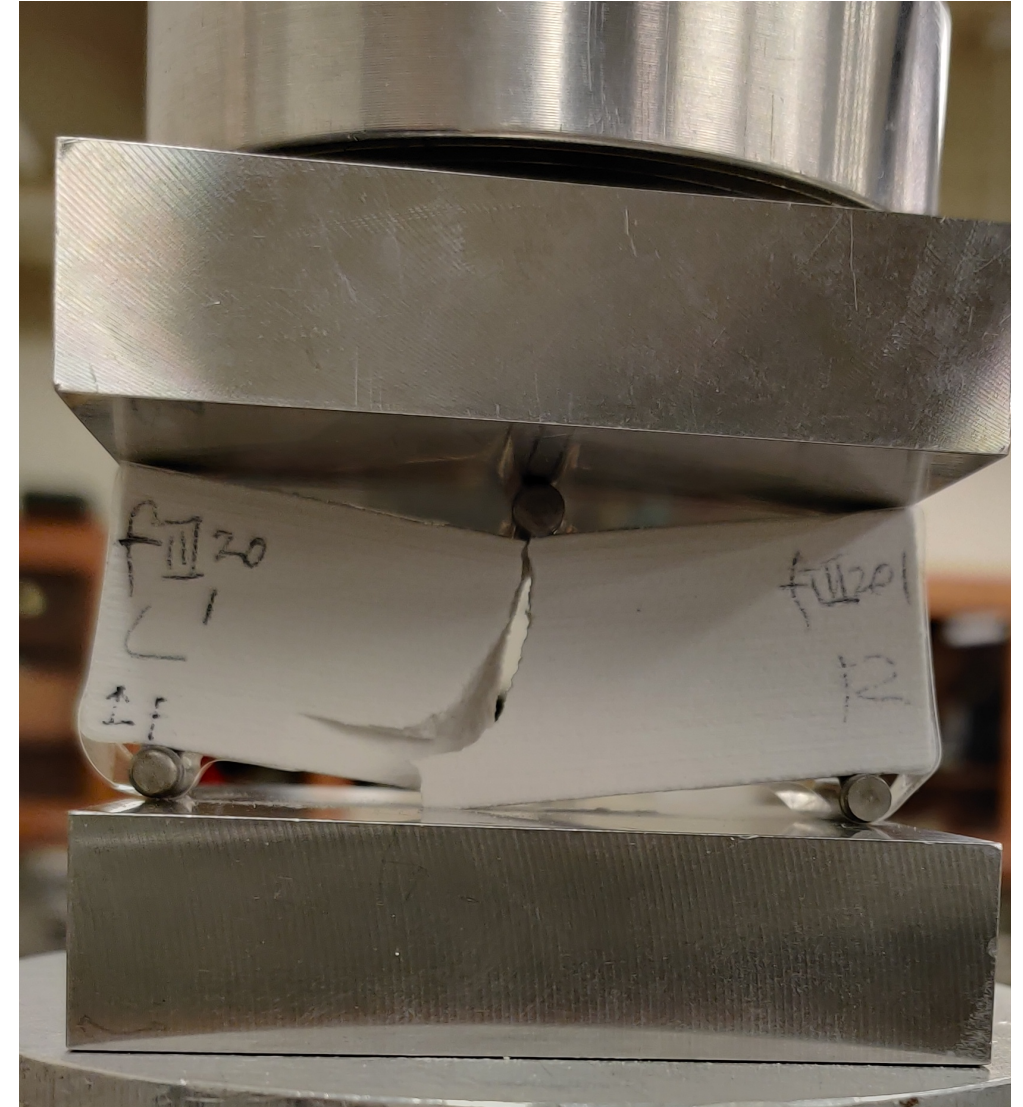

Sample after Failure

Mixed I and III – Failure Load—Fracture Toughness

3PB Tests of Mixed Mode I and III

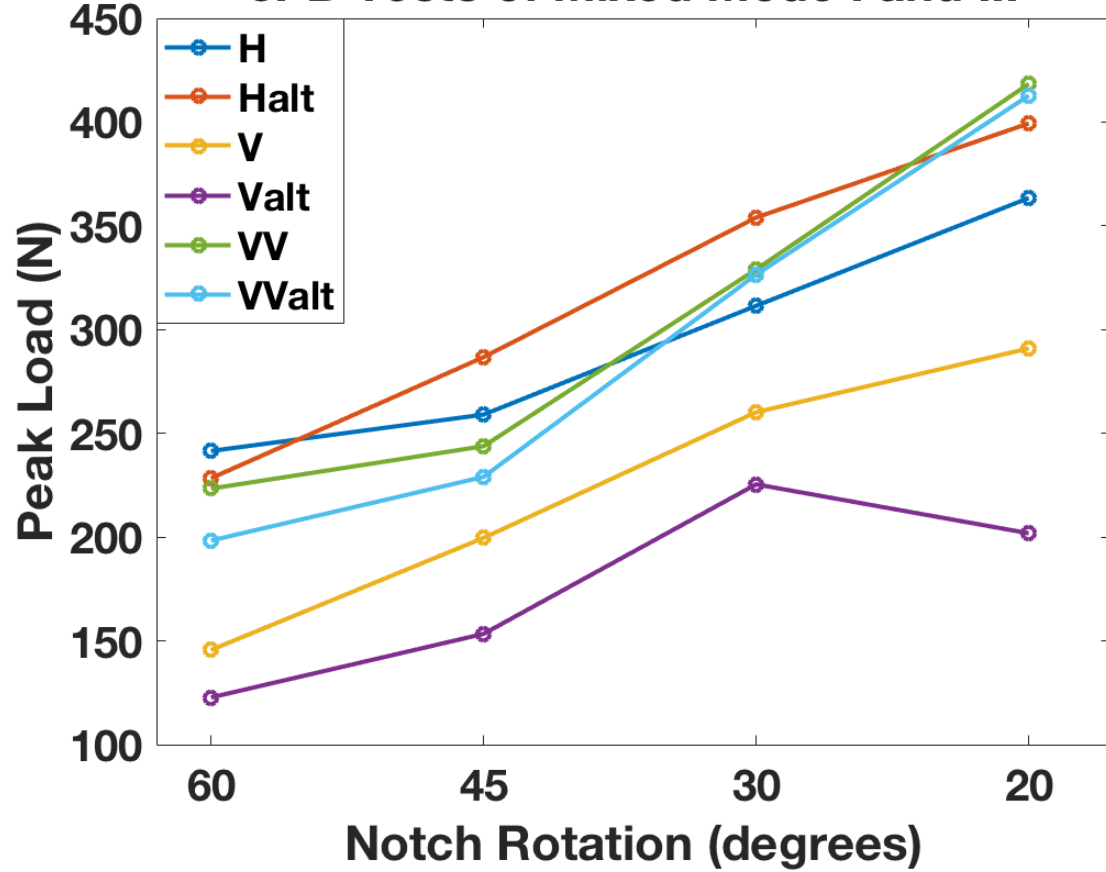

Bottom View of Cracked H Sample

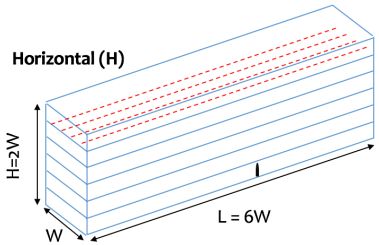

Arrestor (H)

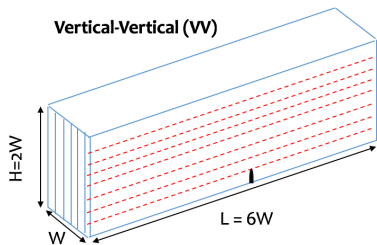

Divider (VV)

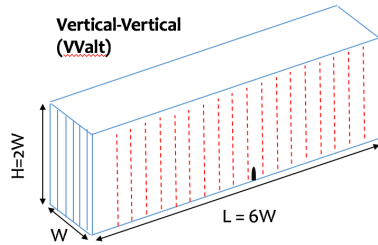

Divider (VValt)

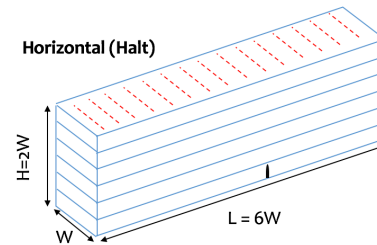

Arrestor (Halt)

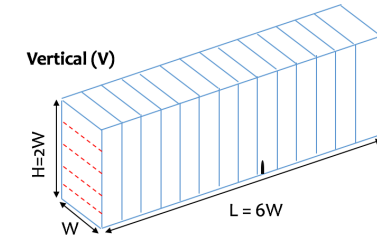

Short-Transverse (V)

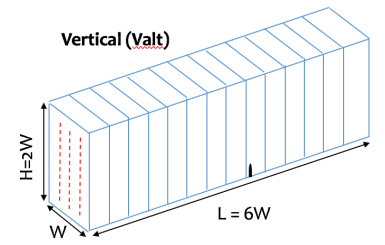

Short-Transverse (Valt)

3D X-ray CT Tomography of Induced Fractures

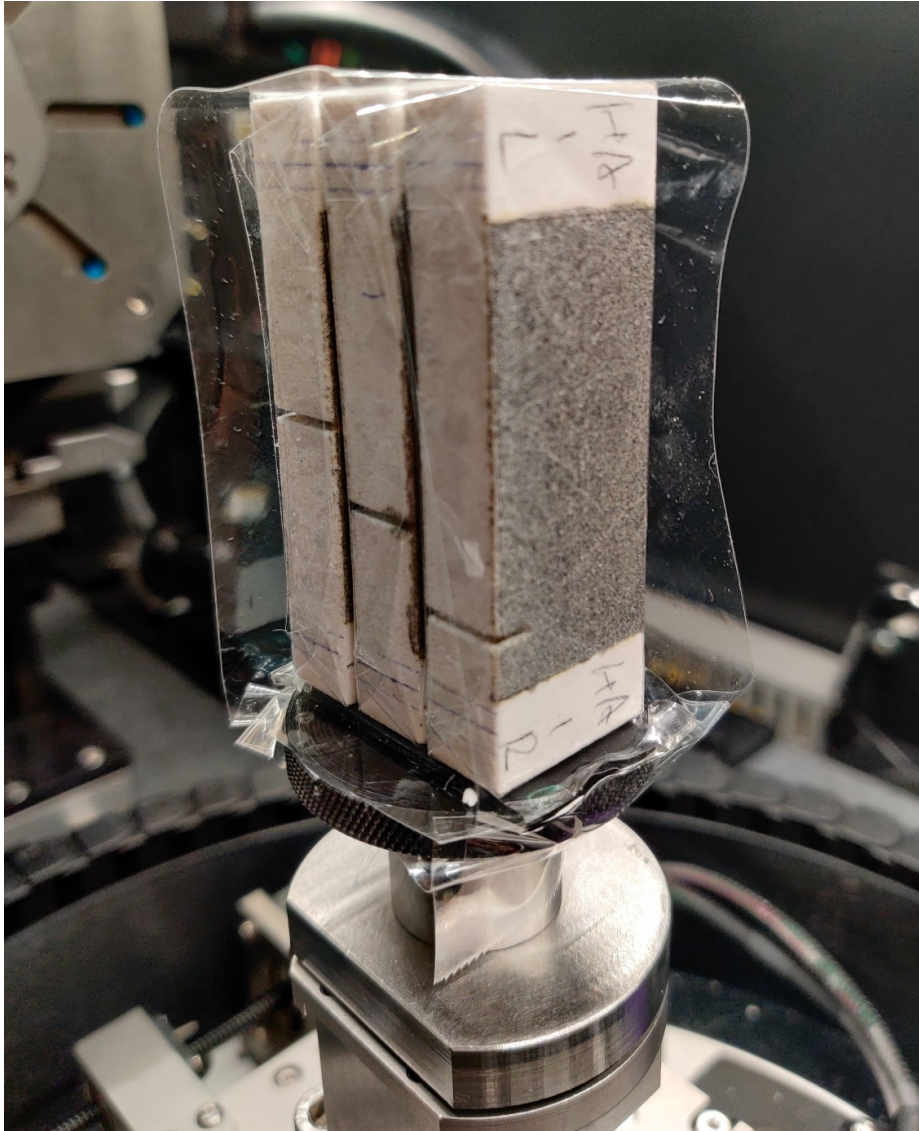

Three samples on stage inside Xray machine

A screenshot of the 'Image Control' software interface. The interface has a menu bar with 'Annotation', 'Info', 'Axes', 'Thermal', and 'Reference'. The 'Info' menu is selected. The main area displays various parameters for the CT tomography scan, including imaging mode, camera settings, source information, and exposure time. There are input fields for several parameters like source setting, source-RA distance, detector-RA distance, pixel size, and exposure time. At the bottom, there are 'Edit' and 'Update' buttons.

| Image Control | | | |
|--|----------------------------|----------------------|---------|
| Annotation Info Axes Thermal Reference | | | |
| Imaging Mode: | Tomography | Source Information | |
| Camera Binning: | 1 | Power: | 9.99 |
| Camera Temperature: | -59 C | Voltage: | 149.83 |
| File Data Type: | USHORT | Target Current: | 66.66 |
| Display Data Type: | FLOAT | Tube Current: | 168.19 |
| Image Size: | 2048 x 2048 | Centering X: | 165.82 |
| File Size: | 25608.000 MB | Centering Y: | 129.14 |
| Source Filter: | Air | Vacuum Level: | 7.23 |
| Source Setting: | 150 kV 67 uA | Focus Current: | 2382.12 |
| Source-RA distance: | 200.0123 mm | Hours on target: | 13.12 |
| Detector-RA distance: | 75.0014 mm | Target turn #: | 574 |
| Pixel size: | 24.9798 um | Filament: | 7.287 |
| Optical Magnification: | 0.39305 : "0.4X" | Cold Cathode Status: | Off |
| Exposure Time: | 4.0000 sec | | |
| Camera Readout: | Fast (2.5 MHz) | | |
| Heated Sample Temp: | NA | | |
| Date and Time: | 09/04/2021 02:09:22.114 | | |
| Frames/Image: | NA | | |
| Exp/Frame: | NA | | |

CT tomography parameters

Segmented Fractures (Notch Rotates 60 degrees)

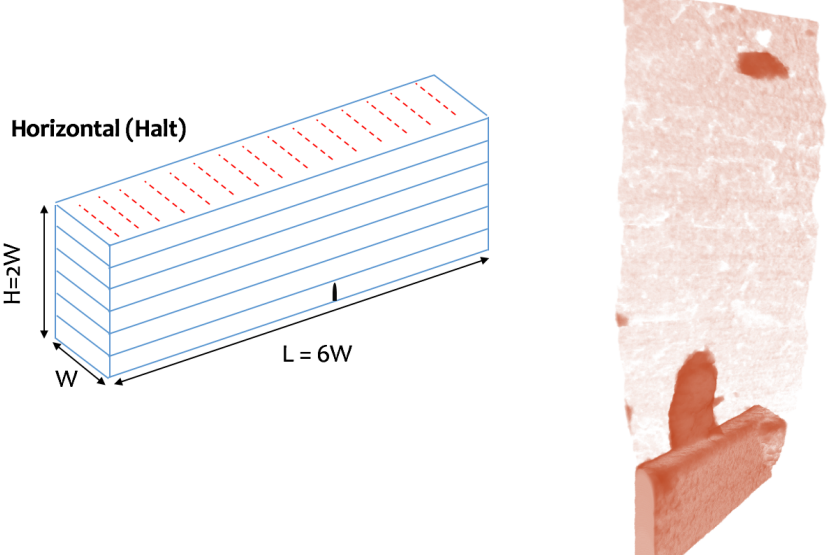
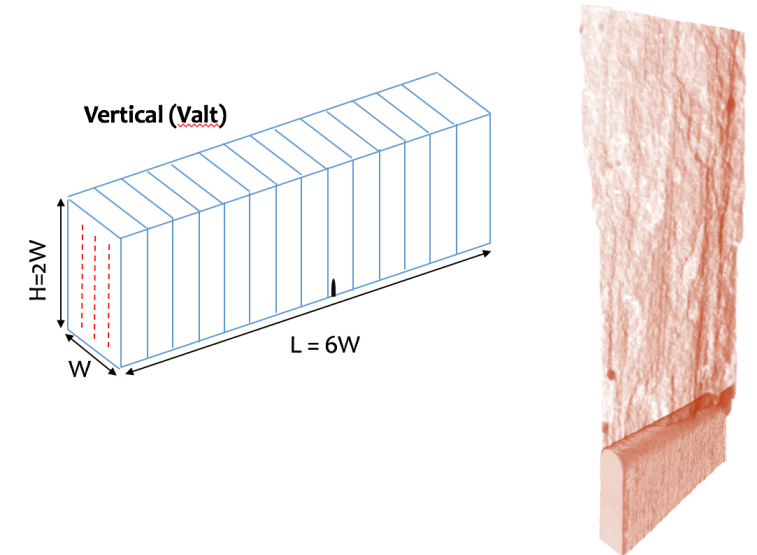
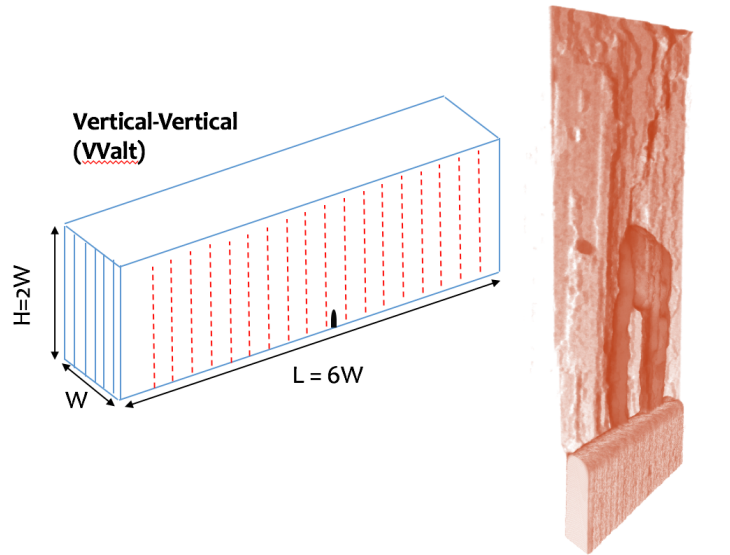
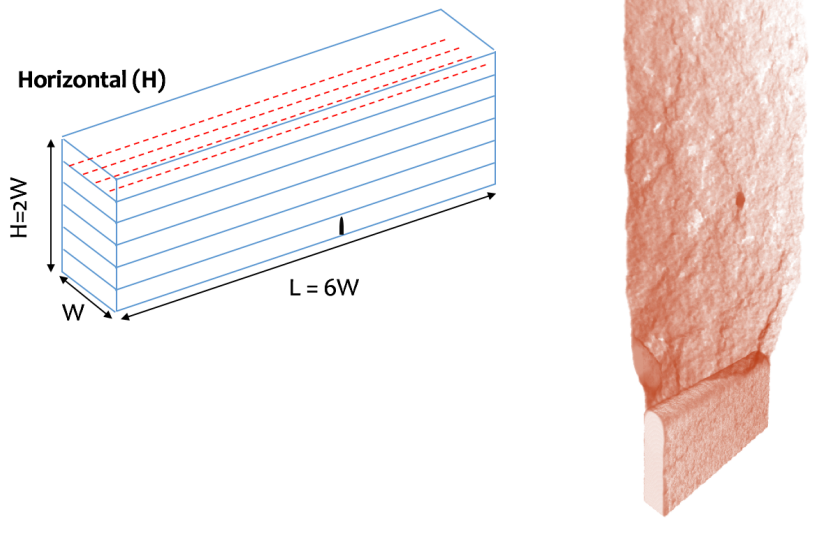
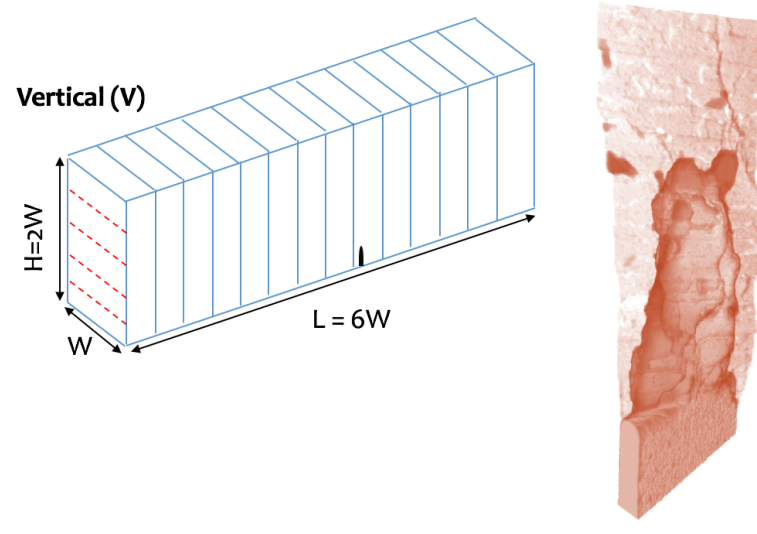
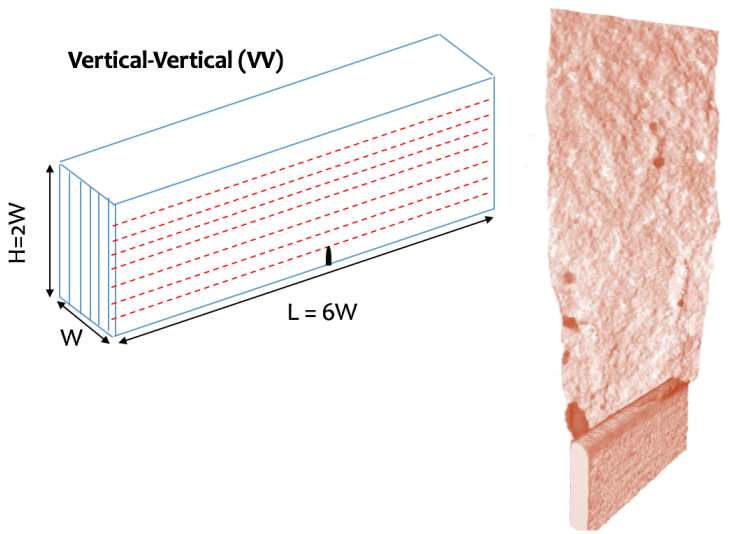

Notch height 5.08 mm

Segmented Fractures (Notch Rotates 45 degrees)

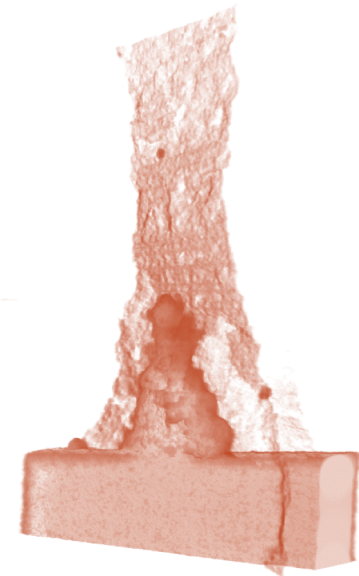
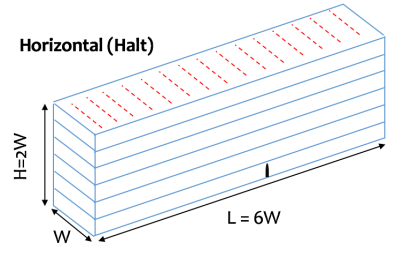
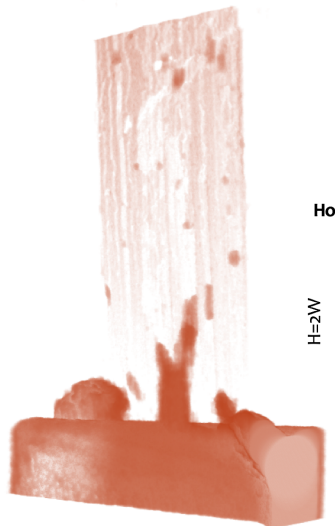
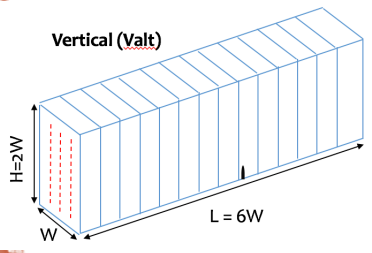
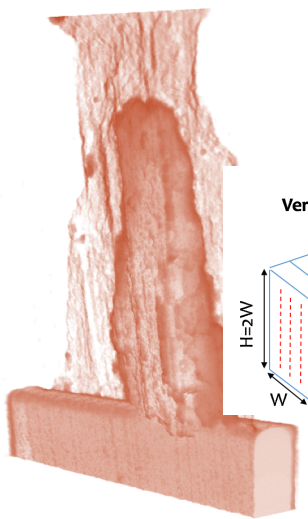
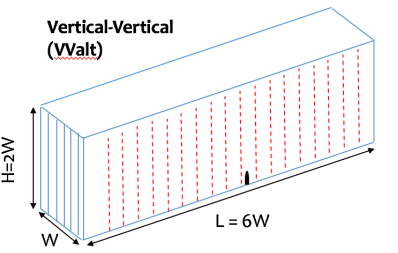
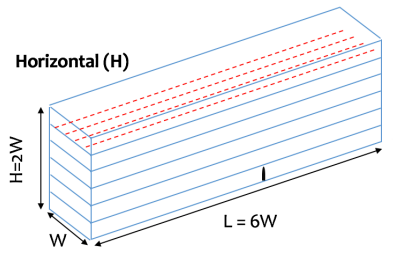
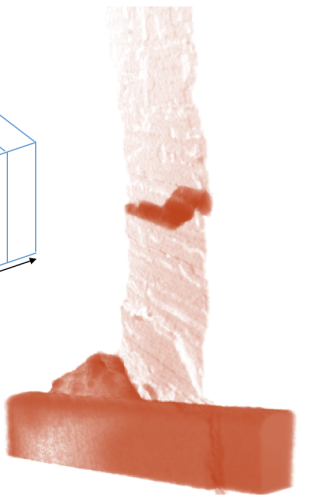
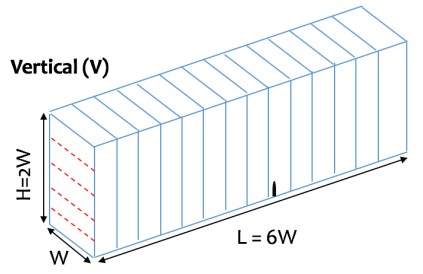
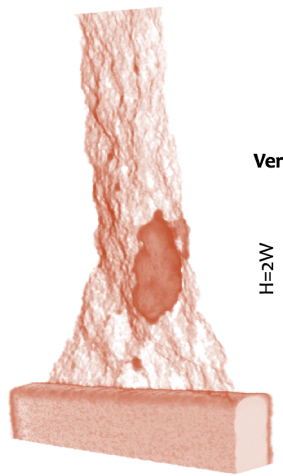
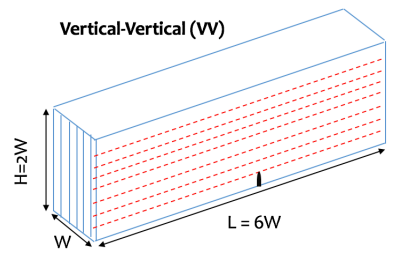

Notch height 5.08 mm

Segmented Fractures (Notch Rotates 30 degrees)

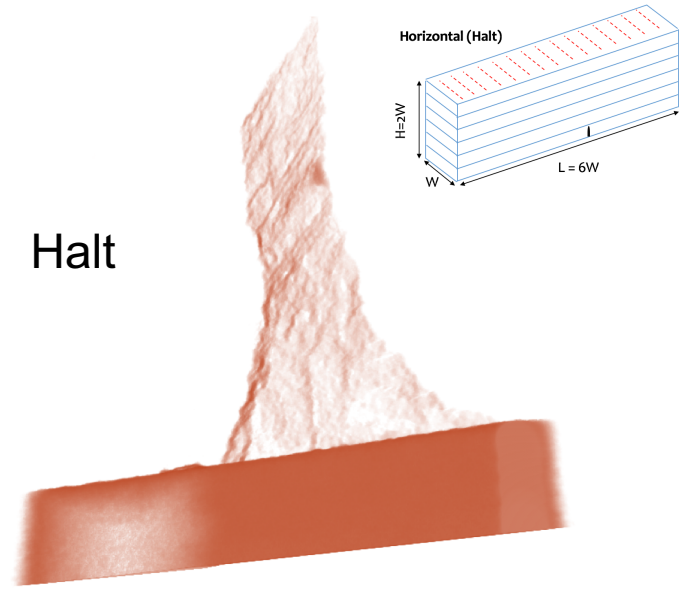
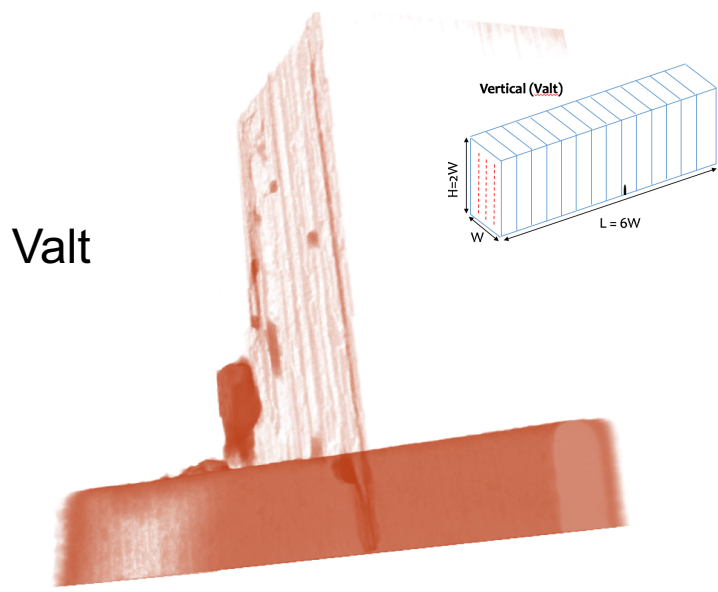
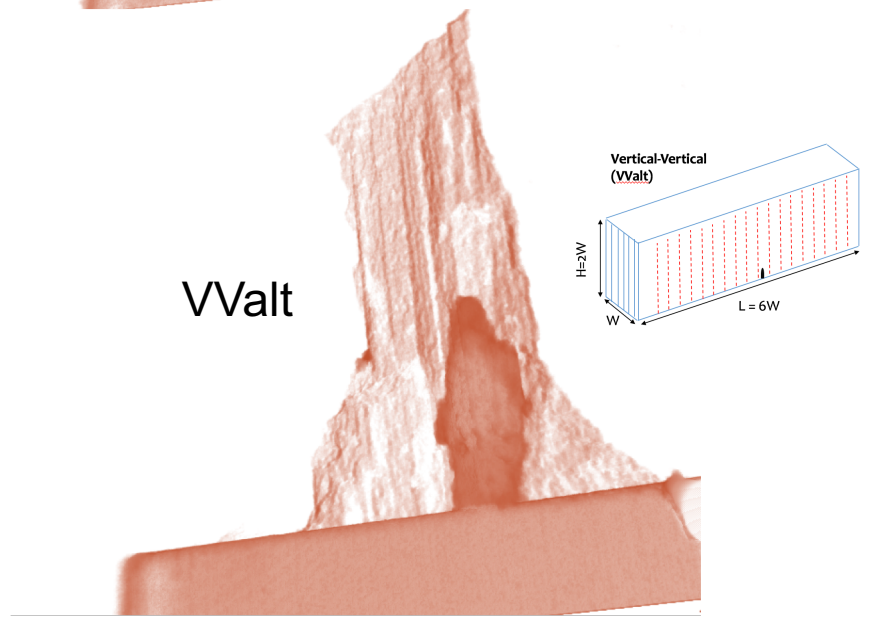
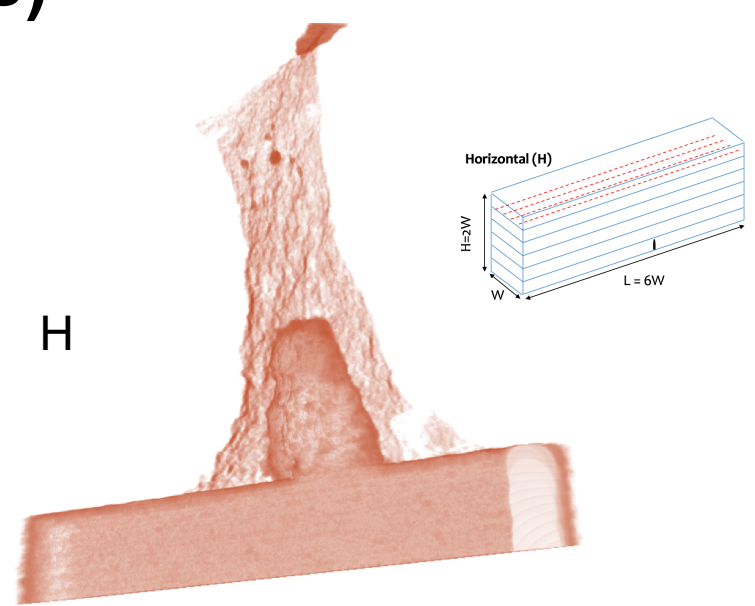
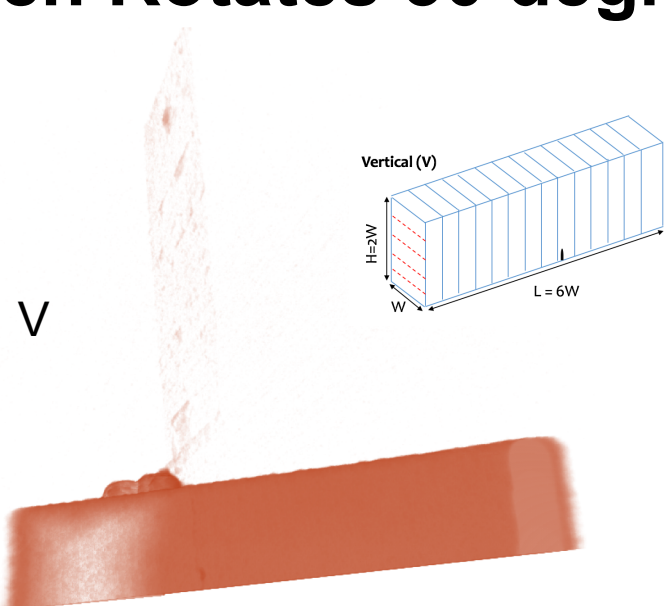
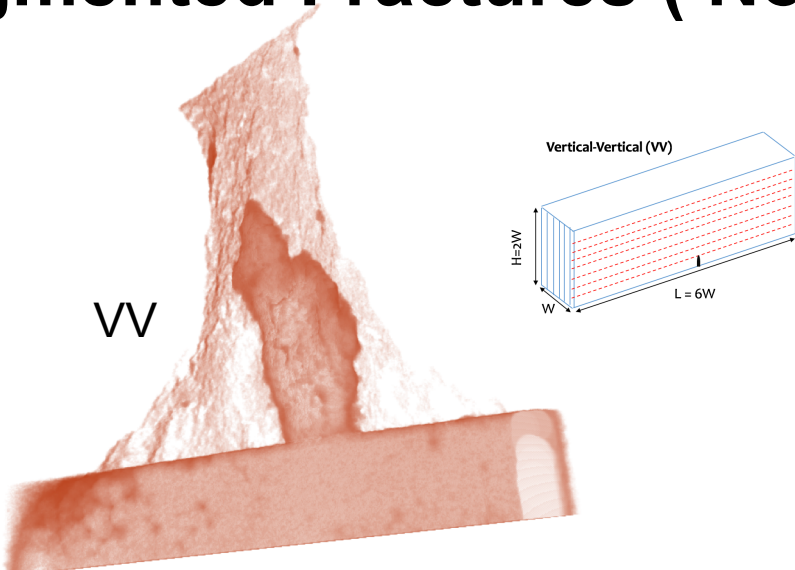

Notch height 5.08 mm

Segmented Fractures (Notch Rotates 20 degrees)

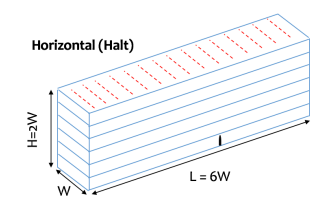
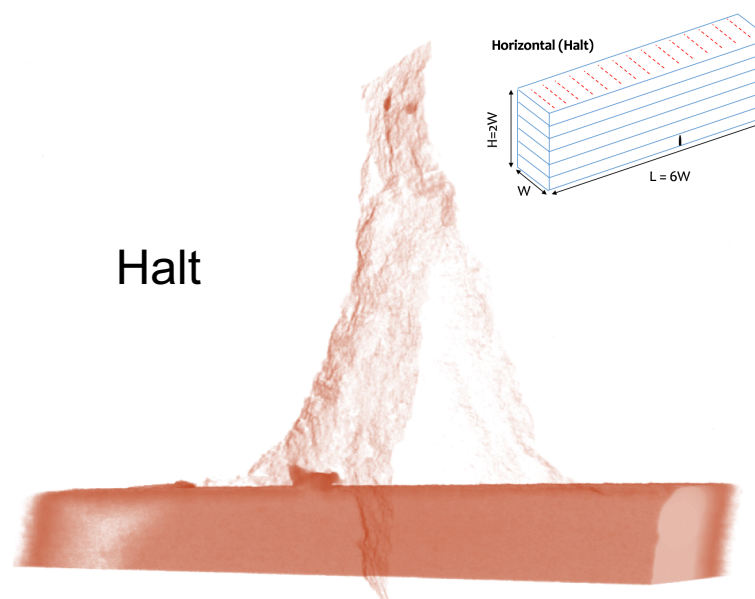
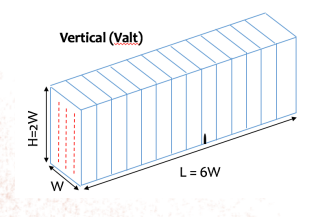
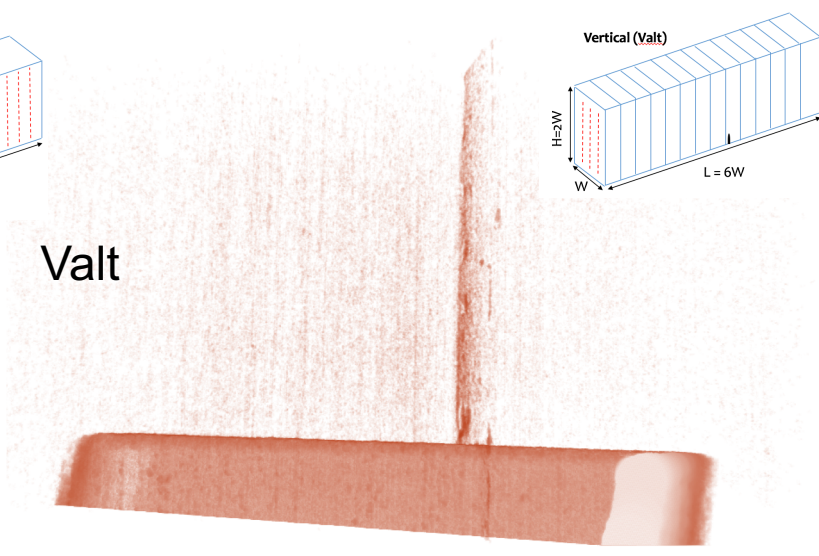
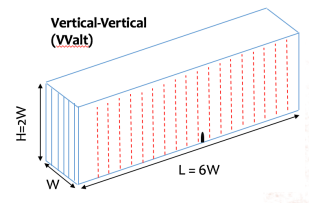
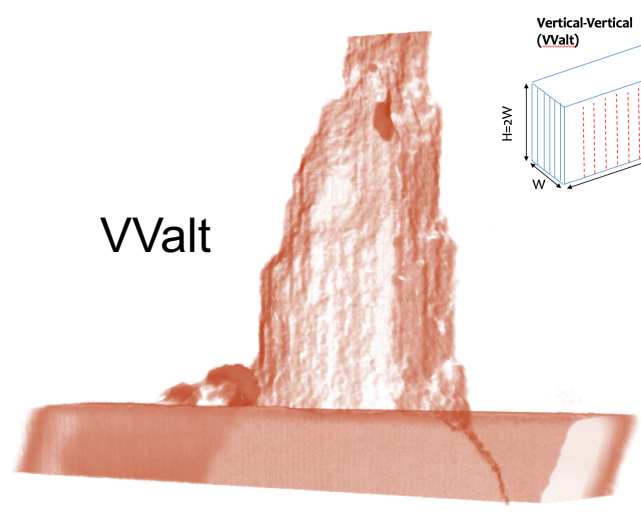
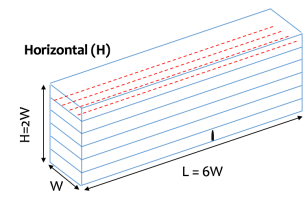
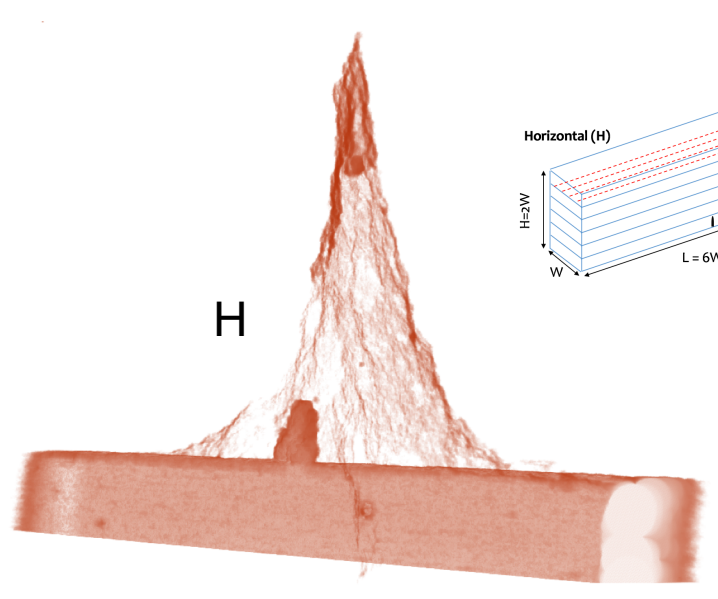
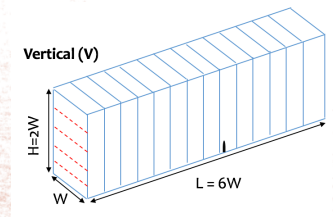
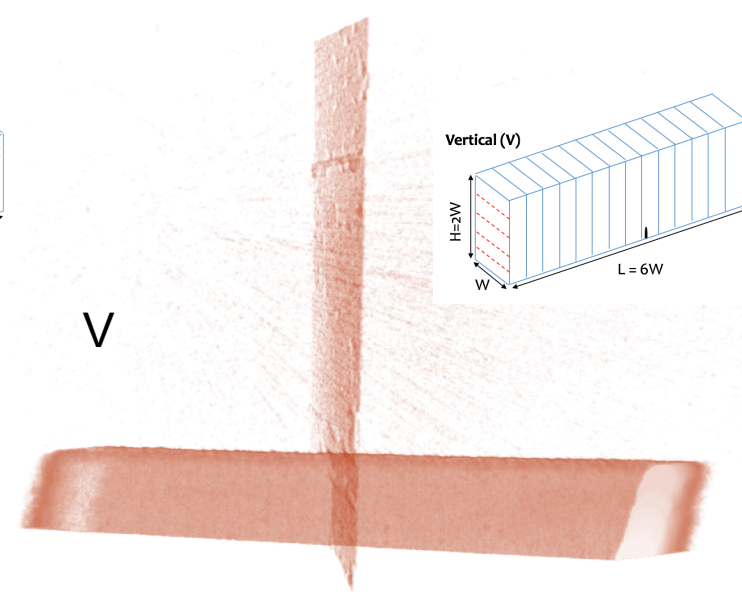
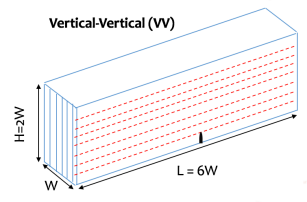
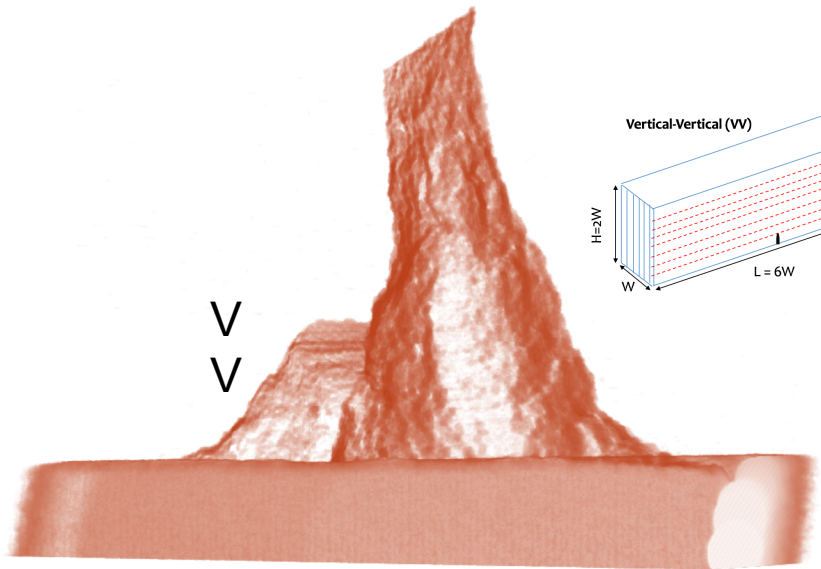

Notch height 5.08 mm

Surface Roughness Measurements: Laser Profilometry

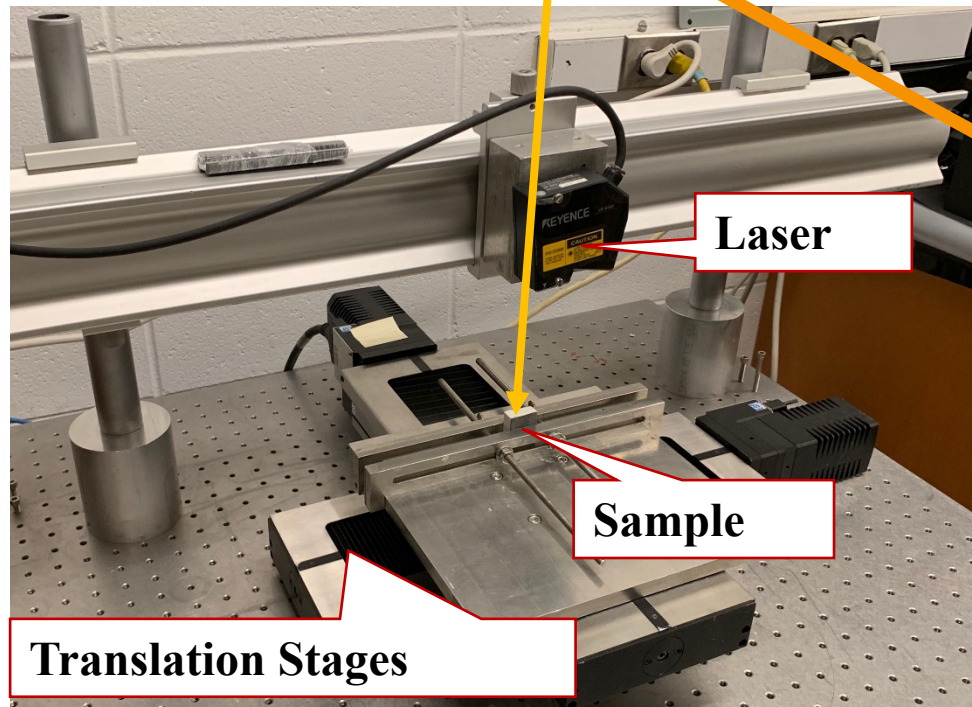

Micro-Slope Analysis with General Twist Removing

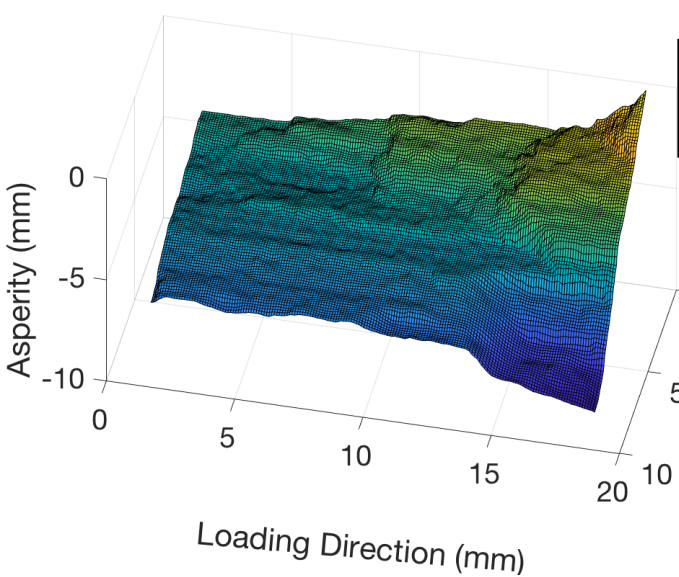

Fit the scanned surface with a 2nd order polynomial

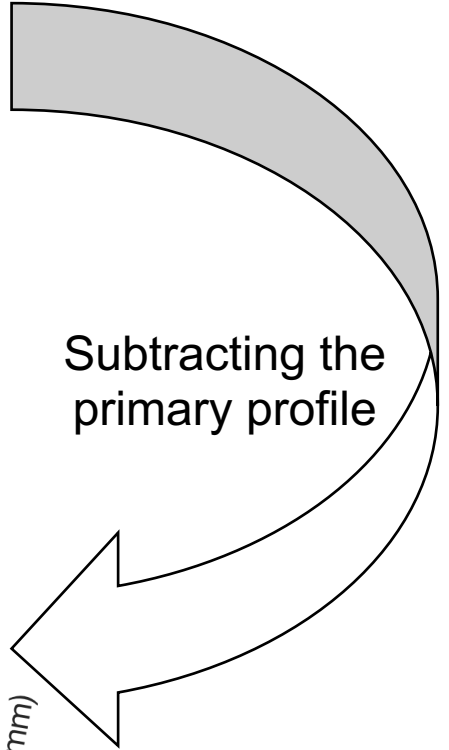
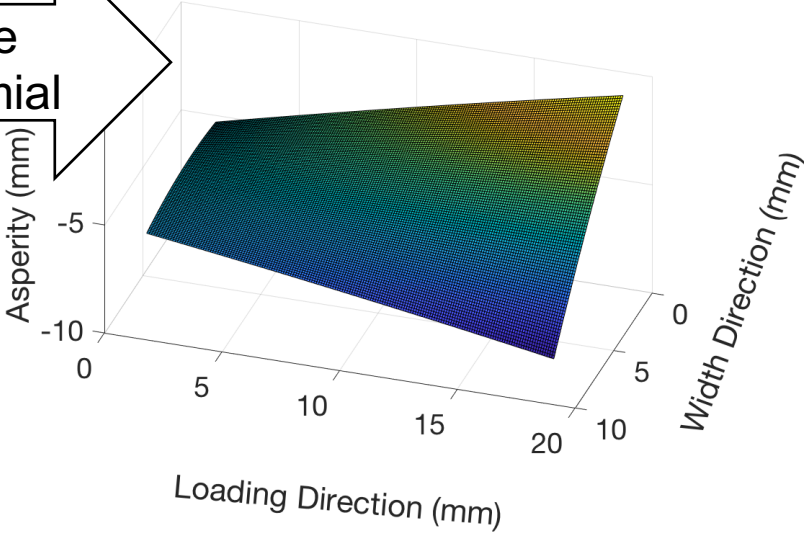

Subtracting the primary profile

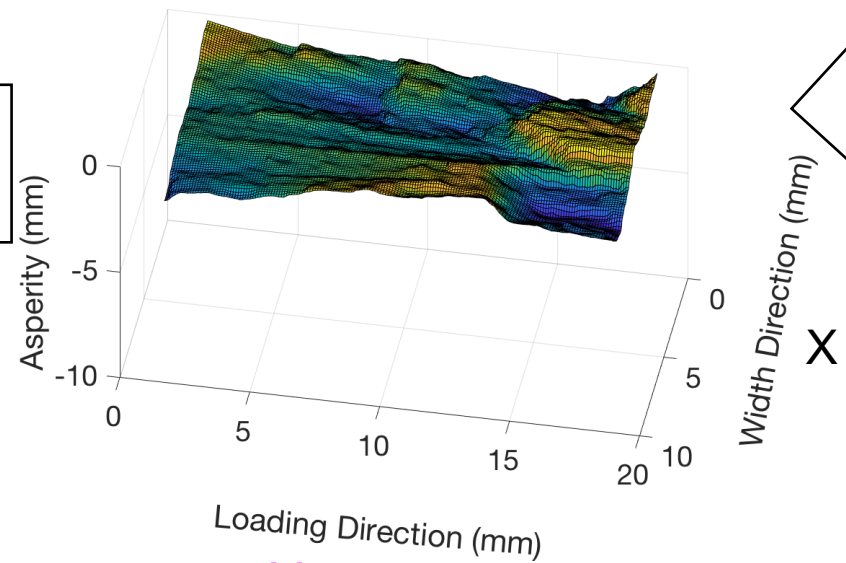

Micro slope distribution from roughness profile

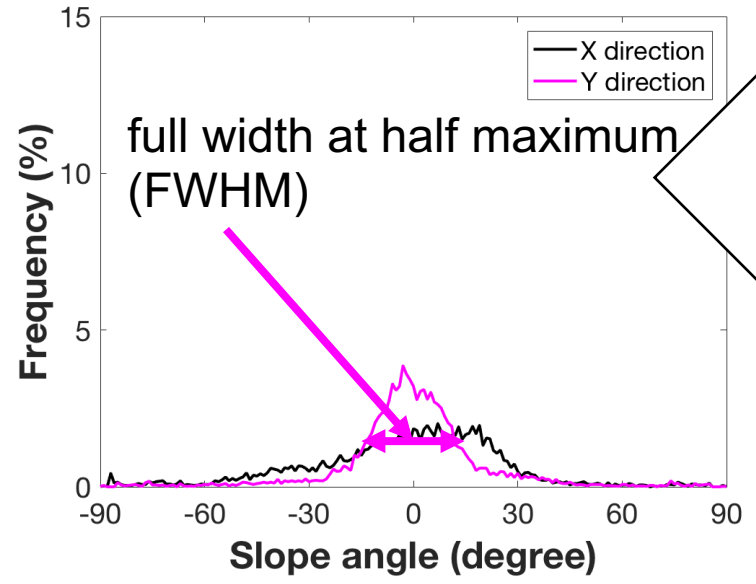

Full Width Half Maximum (FWHM) of Surface Micro Slope Distribution

VV

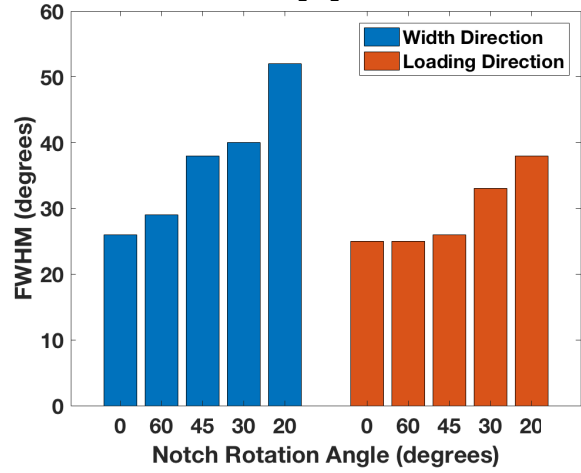

Vertical-Vertical (VV)

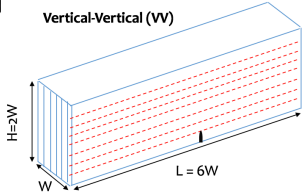

V

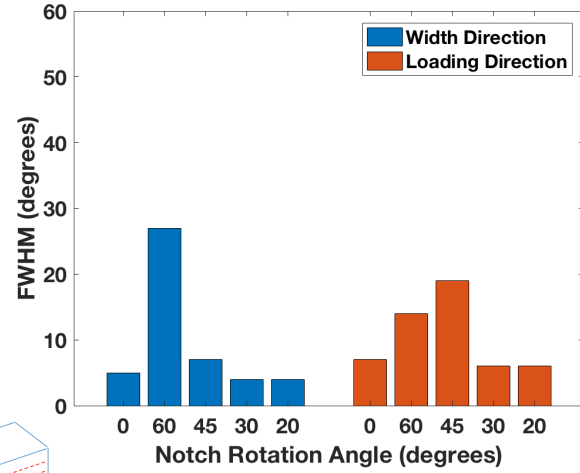

Vertical (V)

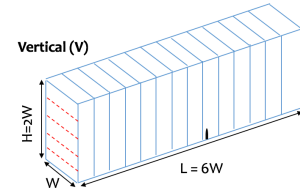

H

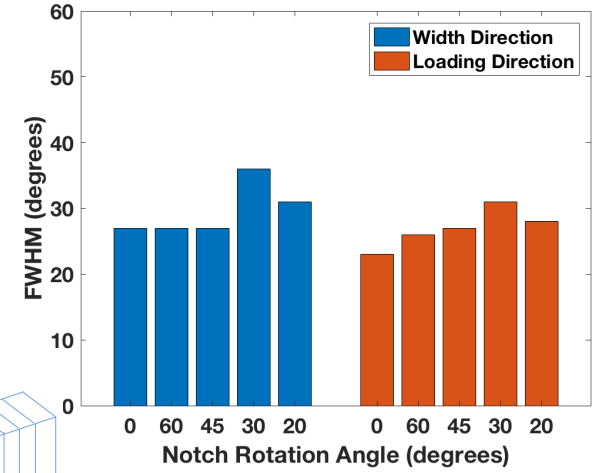

Horizontal (H)

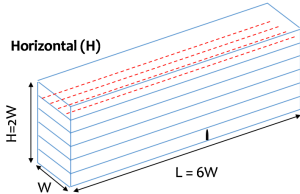

VValt

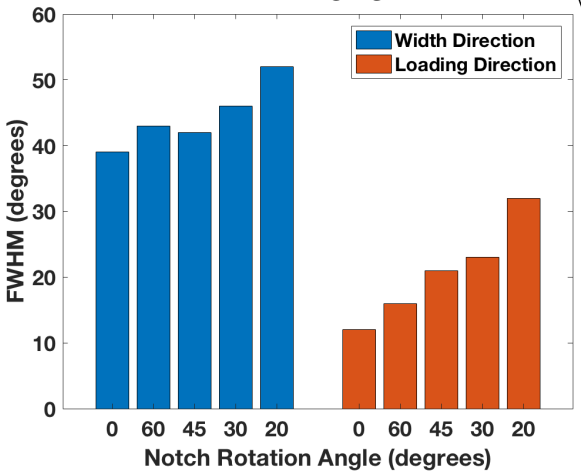

Vertical-Vertical (VValt)

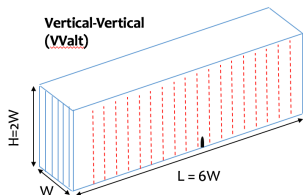

Valt

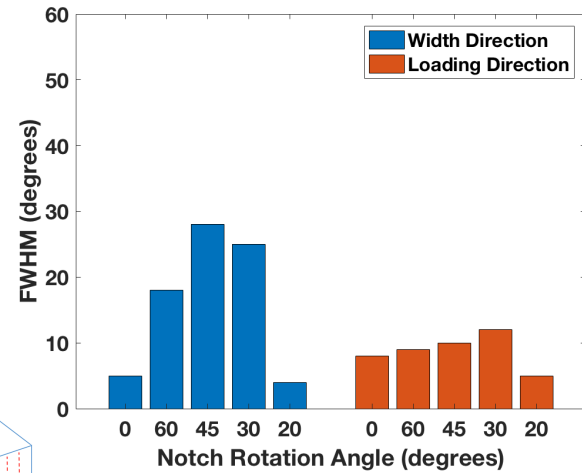

Vertical (Valt)

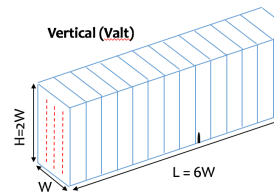

Halt

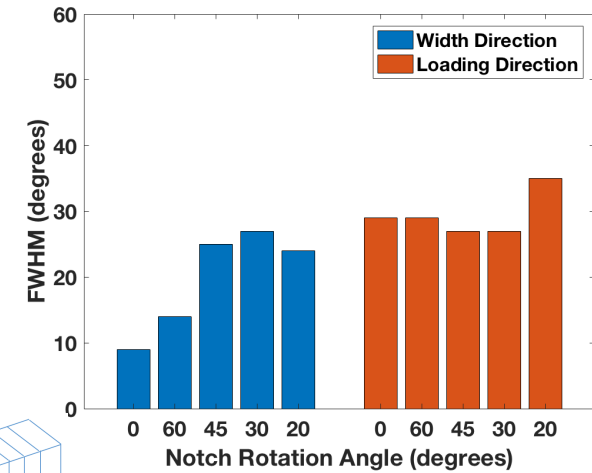

Horizontal (Halt)

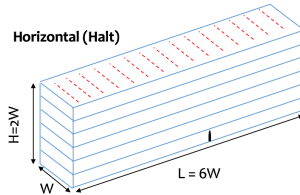

Conclusions

- The direction of layering and in-layer mineral fabric affected the fracture path, toughness, and roughness.
- As the fracture propagated, the fracture surface rotated, tended to become planar and parallel to the loading i.e. becoming a Mode I failure plane.
- Micro-Slope distribution changed when Mode III applied.
- When the mineral fabric or layer directions were parallel to the loading, the induced fracture tended to be planar.

~Thank you for your attention~

Questions?

Liyang Jiang
jiang352@purdue.edu

Advisement of Damage Mechanics Challenge on Brittle-Ductile Material

https://purr.purdue.edu/groups/damage_mechanicschallenge

DMC

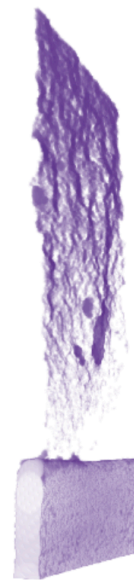

Mode I
Type C

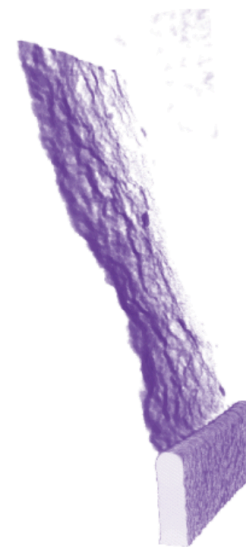

Mode I & II
Type B

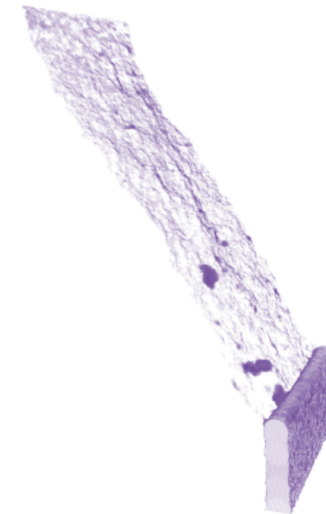

Mode I & II
Type A

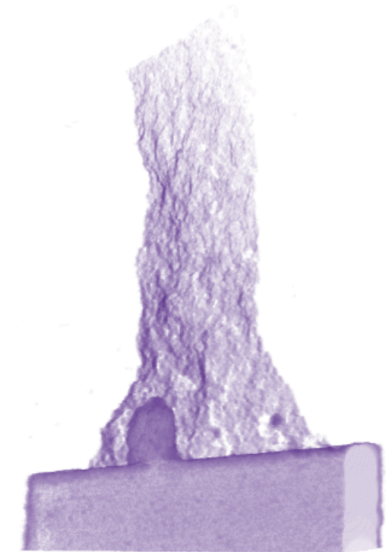

Mode I & III
45 degrees angle

This material is based upon work supported by the National Science Foundation (1932312-CMMI). Sandia National Laboratories is a multimission laboratory managed and operated by National Technology & Engineering Solutions of Sandia, LLC, a wholly owned subsidiary of Honeywell International Inc., for the U.S. Department of Energy's National Nuclear Security Administration under contract DE-NA0003525.