

**FINAL PROJECT REPORT**

**DATE SUBMITTED**

September 14<sup>th</sup>, 2022

**PROJECT PERIOD**

February 1<sup>st</sup>, 2020 - May 31<sup>st</sup>, 2022

**“Fouling-resistant, chlorine-tolerant zwitterionic membranes for treatment of produced water in the Permian Basin”**

**RECIPIENT ORGANIZATION**

ZwitterCo, Inc.

12 Cabot Rd, Suite B  
Woburn, MA 01801

DUNS Number: 081215694

**PRINCIPAL INVESTIGATOR**

Chris Drover, CTO

Phone: 617-682-6848

Email: [cdrover@zwitterco.com](mailto:cdrover@zwitterco.com)

**SUBMITTED BY**

Chris Drover, CTO

Phone: 617-682-6848

Email: [cdrover@zwitterco.com](mailto:cdrover@zwitterco.com)

**SUBMITTED TO**

U.S. Department of Energy  
National Energy Technology Laboratory

## 1. Executive Summary

ZwitterCo has successfully demonstrated the technical and economic feasibility of its zwitterionic superfiltration (SF) membrane technology for the treatment of produced water in the Permian Basin. In-field demonstration of membrane performance using actual produced water has firmly established that the use of SF membranes to treat produced water has reached technology readiness level (TRL) 6. The techno-economic analysis demonstrates that this membrane process is an economically and technologically advantageous desalination pretreatment option for produced waters in the Permian Basin.

A head-to-head comparison against alternative membrane-based pretreatment options, namely standard polymeric and ceramic membranes, and non-membrane pretreatment options, like dissolved gas flotation and walnut shell filtration, shows that ZwitterCo membranes are capable of producing high quality water as a result of their tight molecular weight cutoffs and lower total cost of treatment. The molecular weight cutoff of the ZwitterCo membranes is on the order of 1 kDa. This is in between the nanofiltration and ultrafiltration spectra in a spectrum called superfiltration (SF). The cost of treating produced waters using the ZwitterCo membranes is around \$0.11/bbl which is less than the industry desalination pretreatment target of \$0.20/bbl.

In order to achieve beneficial reuse quality standards, produced water must be desalinated. A TEA of various fully integrated desalination treatment trains were evaluated modeling either ZwitterCo pretreatment or standard polymeric ultrafiltration pretreatment for comparison. The downstream desalination technologies were chosen for this analysis based on current or past commercial produced water treatment use or, at minimum, a pilot demonstrated technology and included the membrane-based technologies of membrane distillation, osmotically assisted reverse osmosis, and conventional reverse osmosis, as well as mechanical vapor compression, a thermal-based technology.

Analysis concluded that the most economical process was a combined ZwitterCo SF and membrane distillation (MD) process, with standard dissolved gas flotation and walnut shell filtration as primary treatment. Total costs, excluding transportation to the beneficial reuse site, disposal of process concentrate, and revenue generated from resale, were \$1.34/bbl of desalinated water. Including initial estimates for concentrate disposal via operator-owned saltwater disposal wells and pipeline transportation to reuse locations, the total cost range is estimated to be \$1.54-\$1.94/bbl of desalinated water before any offsets from resale. This strongly implies that total treatment costs for the ZwitterCo-integrated process are capable of being implemented below the viability threshold. This threshold was determined to be \$2/bbl through the project team's interviews with industry operators and treatment cost targets set by an independent industry group focused on evaluating technologies for beneficial reuse within the Permian basin.

End use opportunities for the desalinated produced water were also evaluated based on criteria including water demand, need, risk, and proximity to current well activity. Top candidate applications were determined to be cooling water for local power plants, cropland irrigation in local irrigation districts, and surface water augmentation to meet the interstate Pecos River compact. Additional applications evaluated but determined to be of low likelihood for implementation included potash mining extraction, rangeland watering, road spreading for dust control, and municipal water use.

## 2. Introduction & Methodology

This report is intended to evaluate the economic viability and technical advantages of using ZwitterCo-integrated produced water treatment in the Permian basin. The overall objective of the project is to receive produced water and generate high quality water for beneficial reuse. Beneficial reuse is the use of treated produced water outside of oil and gas operations for the benefit of the local environment and communities. In this report, potential reuse opportunities are evaluated and ranked on the basis of water demand, proximity to oilfield activity, risk profile, and need.

The focus is on using ZwitterCo's novel SF membrane as pretreatment of produced water upstream of a desalination unit. In this case, the role of the ZwitterCo membrane is to provide ultra-fine filtration in order to prevent fouling and maximize the cost-effectiveness of the desalination unit.

Although the scope of the present study is to evaluate the ZwitterCo SF membrane, ultimately some form of desalination must be added downstream of the SF membrane. Thus, several candidate desalination technologies were included in the TEA analysis as the final treatment step before water reuse. The criteria for selection of desalination technology were

- performance,
- applicability,
- fouling resistance.

Four desalination technologies were ultimately selected for the TEA on the basis of technical capability (or in the case of conventional reverse osmosis, for comparison to the industry standard for desalination):

- Conventional Reverse Osmosis (RO)
- Osmotically Assisted Reverse Osmosis (OARO)
- Membrane Distillation (MD), and
- Mechanical Vapor Compression (MVC)

All of these desalination technologies require deep and effective pre-treatment upstream in order to prevent fouling and maintain sustainable treatment. In order to evaluate the economic performance of several different integrated treatment trains, several competitive candidate pre-treatment technologies were considered, including ZwitterCo's zwitterionic SF membrane—the development of which is the focus of this grant project. Three membrane technologies were found to provide the required level of pre-treatment:

- Conventional polymeric polyethersulfone ultrafiltration (PES UF) membranes,
- Ceramic ultrafiltration membranes (Ceramic UF), and
- ZwitterCo polymeric superfiltration membranes (ZwitterCo SF).

Each of these technologies is considered to be a “barrier” technology. Barrier technologies perform at a very high level of separation and recovery efficiency and are capable of delivering high quality water to the chosen desalination technologies so that they can operate with minimal fouling tendency. Fouling is detrimental to performance and water quality. Fouling causes increased downtime, shorter component life, greater cleaning-chemical usage, and higher

electricity cost. In addition to the ultrafiltration membranes listed above, dissolved gas flotation (DGF) and walnut shell filtration (WSF) were also evaluated. These are considered only as a baseline of comparison among pretreatment options, given that their lower quality effluent (as compared to UF pretreatment) is not suitable for pretreatment to desalination. Later, in evaluating full treatment trains, DGF and WSF are considered as primary treatment ahead of the desalination pretreatment step due to their low cost and beneficial effects on ultrafiltration/superfiltration performance and longevity.

The TEA modeling and analysis provides a systematic and head-to-head comparison of capital expenses (CAPEX) and operating expenses (OPEX) for the different desalination and ultrafiltration pre-treatment technologies. The overall methodology was to break down the OPEX and CAPEX into more detailed components that could each be verified against external sources and estimated with some degree of accuracy. OPEX was broken into:

- Membrane or internal element replacement
- Labor
- Electricity
- Miscellaneous spares and maintenance
- Chemicals

Input for these items was obtained from vendors, personal experience, scientific literature, ZwitterCo pilot data and from operators in the industry. The ZwitterCo pilot data on produced water treatment is located in Section 2.1 of this document.

In order to evaluate CAPEX of the various process technologies, bids were requested from vendors when possible, with the following breakdowns and specifications:

- Skidded system including instrumentation, controls, valves, pumps,
- Chemical cleaning system for membrane systems,
- API oil and gas specifications for pumps, piping, safety, and venting/relief systems
- Materials suitable for oxygen-containing, high salinity water

CAPEX did not include site preparation, utilities infrastructure, nor transportation of equipment to site. CAPEX information was obtained from vendors, literature, and operators. In most cases, the vendors were able to provide highly detailed cost information in the form of a typical bid package.

In a process lineup, pretreatment with UF or SF membranes is followed directly by treatment for desalination. In all process lineups considered, Dissolved Gas Flotation (DGF) and Walnut Shell Filtration (WSF) are used as the first steps, and the furthest upstream. A comparison is then made between the three membrane systems listed above (conventional, ceramic, and ZwitterCo). The focus of this unit process analysis is on the cost comparison between the ZwitterCo membrane and the other pretreatment technologies considered. However, in order for the ZwitterCo membrane to be a viable pretreatment technology, the entire process train must be considered including its effects on the downstream desalination process. The cost benefit of a high performing pretreatment technology, like ZwitterCo SF, comes about through longer equipment life, fewer cleanings, less chemical demand per cleaning, high fluxes, and higher overall recovery.

There are three important factors that are commonly used to calculate CAPEX and OPEX in terms of (a) present value of money, (b) lump sum cost of capital, and (c) unit cost (amortized CAPEX plus OPEX per unit volume of water). These factors are:

1. CCF (Cost Capacity Factor) – this allows scale-up and scale-down of cost information.
2. CEPCI (Chemical Engineering Plant Cost Index) – this allows for the variable cost of equipment over time,
3. CRF (Capital Recovery Factor) – this allows for the calculation of per-barrel costs of capital. The CRF is a financial term. As such, “recovery” refers to the rate at which capital is amortized and is not related to the recovery rate of water flowing through a membrane.

The TEA spreadsheet (*Appendix A*) provides a separate worksheet for the calculation of each of these factors.

The CAPEX and OPEX for each desalination technology are calculated on separate tabs. All membrane pretreatment technologies are calculated on the same tab so that they can be easily compared. A summary of the calculated CAPEX and OPEX for each technology is given in the tab labeled “Unit TEA.” Calculations for various systems (process configurations) are calculated in the tab labeled “System TEA.” All capital costs were amortized over 10 years and calculated on the basis of a 20,000 bbl of feed water/day treatment capacity.

## **2.1. Piloting Report**

### **2.1.1. Introduction**

The ZwitterCo SF membrane was pilot tested on Permian Basin produced water to validate the membrane technology’s progression to Technology Readiness Level (TRL) 5 (Office of Environmental Management, 2010). Requirements for TRL 5 technologies are described below:

- The basic technological components are integrated so that the system configuration is similar to (matches) the final application in almost all respects. Examples include testing a high-fidelity, laboratory scale system in a simulated environment with a range of simulants and actual waste.
- The supporting information includes results from the laboratory scale testing, analysis of the differences between the laboratory and eventual operating system/environment, and analysis of what the experimental results mean for the eventual operating system/environment.
- The major difference between TRL 4 and 5 is the increase in the fidelity of the system and environment to the actual application. The system tested is almost prototypical.

The testing successfully demonstrated that by using a pilot system similar to that of a full-scale system the ZwitterCo SF membranes could be used to effectively treat produced water so that it

can be further treated for reuse in a desalination step. This pilot report includes details on the testing methodology, results, and implications for full-scale implementation and the TEA.

## 2.1.2. Testing Goals

The primary goals of the pilot testing are listed below:

- Operate for at least 500 hours of cumulative runtime.
- Operate for at least one 168-hour operation window with a maximum of 5% equipment downtime, including any required cleanings.
- Demonstrate that the permeate meets the following water quality criteria on average: silt density index (SDI) < 1; total petroleum hydrocarbons (TPH) < 10 mg/L or oil and grease (O&G) measured as hexane extractable materials (HEM) < 10 mg/L; iron < 2 mg/L. These water quality metrics were selected because they were identified as the water quality requirements for a downstream membrane distillation system.

## 2.1.3. Methodology

### 2.1.3.1. Pilot Schedule, Location, and Source Water

The pilot testing took place from February 2022 through early April 2022. Over the course of the testing, the pilot operated for 26 days of 24 hour runs (typical run length), which is over 600 hours of pilot run time.

The pilot testing was conducted at the Brackish Groundwater National Desalination Research Facility at Alamogordo, NM. Gun-barrel separated produced water from the Permian Basin was sourced through a midstream water company. The water was trucked to the testing facility and stored in a 5,000-gallon storage tank at the site. The produced water in the storage tank was replenished on an as-needed basis. The water quality characterization of the produced water is described in the table below.

*Table 1: Permian Basin Gun-Barrel Separated Produced Water Characterization*

Parameter	Units	Min	Average	Max	N
Turbidity	NTU	20.2	31.3	46.1	16
Oxidation-Reduction Potential (ORP)	mV	-194.0	-126.9	-73.0	8
Oil & Grease (Hexane Extr)	mg/L	ND	ND	ND	6
TPH - Oil & Grease	mg/L	ND	ND	ND	4
Iron	mg/L	8.5	17.8	34.5	5
Iron, Dissolved	mg/L	ND	20.5	31.2	5
Silicon	mg/l as SiO <sub>2</sub>	6.8	9.9	12.6	3

Parameter	Units	Min	Average	Max	N
Silicon, Dissolved	mg/l as SiO <sub>2</sub>	ND	11.7	12.7	4
Alkalinity, Bicarbonate	mg/L	152.0	178.0	200.0	4
Alkalinity, Carbonate	mg/L	ND	ND	ND	4
Dissolved Solids	mg/L	113,000	137,250	161,000	4
Suspended Solids	mg/L	22.8	77.3	182.0	4
Sulfate	mg/L	601.0	643.3	671.0	4
Ammonia Nitrogen	mg/L as N	379	453	533	4
Kjeldahl Nitrogen, TKN	mg/L as N	57	288	392	4
COD	mg/L	4,730	9,090	13,600	4
BOD	mg/L	69.3	420.8	1,000.0	4
DOC	mg/L	37.9	64.5	85.9	4
TOC (Total Organic Carbon)	mg/L	53.4	73.4	91.9	4
Acetone	mg/L	ND	1.2	1.4	4
Ethylbenzene	mg/L	ND	0.1	0.1	4
Toluene	mg/L	0.2	0.5	0.8	4
Xylenes, Total	mg/L	ND	0.1	0.1	4
Benzene	mg/L	ND	0.2	0.3	4
Acetic Acid	mg/L	0.0	45.3	74.0	3
Formic Acid	mg/L	27.0	263.5	500.0	4

### 2.1.3.2. Pilot System Schematic

The ZwitterCo SF system was designed for operating in feed-and-bleed mode, and a piping and instrumentation diagram (P&ID) for the test system is illustrated in Figure 1. The raw produced water, stored in the raw water storage tank at the site (not shown in the diagram), was pumped with the feed water pump and filtered by the filter (20  $\mu$ m cartridge filter). A circulation pump kept the necessary crossflow rate in the membrane element, which was then controlled by a flow control valve (FCV). A small flow of concentrate was discharged to maintain desired permeate recovery. A clean-in-place (CIP) / maintenance wash (MW) tank was also included in the system for membrane cleaning. Raw feed, SF feed, permeate, and concentrate samples were taken at the sampling locations in Figure 1 for water quality analytics. The operating specifications for the membrane elements are listed in Table 2 below.

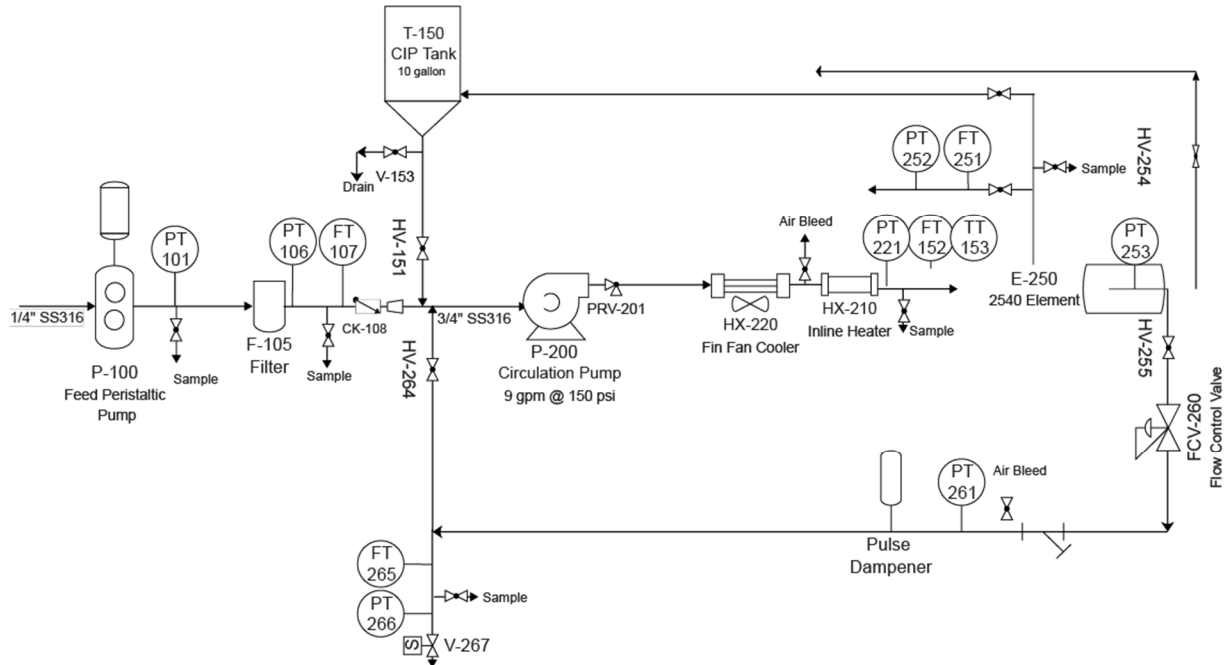

Figure 1: PID of the ZwitterCo SF pilot skid

Table 2: ZwitterCo SF Membrane Operating Specifications

Parameter	Recommended Range	Maximum
Temperature Range	45 – 95°F	105°F
pH	2 – 12	1 – 13
Transmembrane Pressure	30 – 120 psi	220 psi
Axial Pressure Drop	9 – 14.5 psi	14.5 psi
Crossflow (2.5" element)	1.2 – 4 gpm	-

### 2.1.3.3. Sampling and Analytical Plan

The following sampling schedule was developed to characterize the feed water quality, validate the pilot water quality goals with respect to the primary water quality key performance indicators (KPIs), and monitor the concentration of secondary contaminants of interest. Primary water quality KPIs were identified as typical water quality requirements for desalination systems downstream of the ZwitterCo system that could be removed using the ZwitterCo SF membranes. Secondary water quality contaminants were identified as contaminants used for process monitoring or were contaminants that relate to the reuse potential of the feed stream. The sampling and analytical plan is summarized in Table 3. Samples of the feed water quality were divided between the raw feed and the SF feed.



Table 3: Sampling and Analytical Plan

Analysis	Method	Stream	Frequency	Type (Grab/Comp.)	Lab (On-Site/3 <sup>rd</sup> Party)
<b>Primary (required in the Project KPI)</b>					
SDI	ASTM D4189-07 or equivalent	Feed	2/week	Grab	On-Site
		Permeate	2/week	Grab	
		Concentrate	--	--	
HEM	EPA 1664A	Feed	2/week	Grab	Outside lab
		Permeate	2/week	Composite	
		Concentrate	2/week	Composite	
Total Iron	EPA 200.7	Feed	2/week	Grab	Outside lab
		Permeate	2/week	Composite	
		Concentrate	2/week	Composite	
Dissolved Iron	EPA 200.7	Feed	2/week	Grab	Outside lab
		Permeate	--	Composite	
		Concentrate	2/week	Composite	
<b>Secondary (for process monitoring)</b>					
Turbidity	Nephelometric	Feed	Daily	Grab	On-Site
		Permeate	Daily	Grab	
		Concentrate	Daily	Grab	
Conductivity	Conductivity meter	Feed	Daily	Grab	On-site
		Permeate	Daily	Composite	
		Concentrate	Daily	Composite	
pH	pH meter	Feed	Daily	Grab	On-Site
		Permeate	Daily	Composite	
		Concentrate	Daily	Composite	
Silica	Colorimeter	Feed	2/week	Composite	On-Site
		Permeate	2/week	Composite	
		Concentrate	2/week	Composite	
COD	Colorimeter	Feed	Daily	Grab	On-Site
		Permeate	Daily	Composite	
		Concentrate	Daily	Composite	
Alkalinity (Carbonate, Bicarbonate)	SM 2320 B- (1997)	Feed	Weekly	Grab	Outside lab
		Permeate	Weekly	Composite	
		Concentrate	Weekly	Composite	
Total Metals (Si as SiO <sub>2</sub> , Ba, P, K, S, Ca, Mg, Na, Zn, Cu, B)	EPA 200.7	Feed	Weekly	Grab	Outside lab
		Permeate	Weekly	Composite	
		Concentrate	Weekly	Composite	
Dissolved Metals	EPA 200.7	Feed	Weekly	Grab	Outside lab
		Permeate	--	--	

(Si as SiO <sub>2</sub> , Ba, P, K, S, Ca, Mg, Na, Zn, Cu, B)		Concentrate	Weekly	Composite	
Inorganic Ions (Chloride, Sulfate)	EPA 300.0	Feed	Weekly	Grab	Outside lab
		Permeate	Weekly	Composite	
		Concentrate	Weekly	Composite	
TSS	SM 2540 D-(2011)	Feed	Weekly	Grab	Outside lab
		Permeate	--	--	
		Concentrate	Weekly	Composite	
TDS	SM 2540 C-(2011)	Feed	Weekly	Grab	Outside lab
		Permeate	Weekly	Composite	
		Concentrate	Weekly	Composite	
COD	SM 5220 D (2011)	Feed	Weekly	Grab	Outside lab
		Permeate	Weekly	Composite	
		Concentrate	Weekly	Composite	
BOD	SM 5210 B	Feed	Weekly	Grab	Outside lab
		Permeate	Weekly	Composite	
		Concentrate	Weekly	Composite	
TOC	SM 5310 B	Feed	Weekly	Grab	Outside lab
		Permeate	Weekly	Composite	
		Concentrate	Weekly	Composite	
DOC	SM 5310 B	Feed	Weekly	Grab	Outside lab
		Permeate	--	Composite	
		Concentrate	Weekly	Composite	
Volatile Organic Compounds	EPA 8260 D	Feed	Weekly	Grab	Outside lab
		Permeate	Weekly	Composite	
		Concentrate	Weekly	Composite	
TKN	PAI-DK01	Feed	Weekly	Grab	Outside lab
		Permeate	Weekly	Composite	
		Concentrate	Weekly	Composite	
Ammonia	SM 4500-NH <sub>3</sub> C-(1997)	Feed	Weekly	Grab	Outside lab
		Permeate	Weekly	Composite	
		Concentrate	Weekly	Composite	
Organic Acids (lactic, acetic, propionic, butyric)	AOAC 986.13	Feed	Weekly	Grab	Outside lab
		Permeate	Weekly	Composite	
		Concentrate	Weekly	Composite	

Note: The outside lab (unless otherwise specified):

Pace Analytical  
400 West Bethany Dr, Suite 190  
Allen, TX 75013

## 2.1.4. Pilot Testing Results

During the pilot testing, the ZwitterCo membranes were evaluated with respect to operational process parameters and the permeate water quality. Results on each of these areas are described in the following sections.

### 2.1.4.1. Process Parameter Optimization

Pilot testing was conducted to evaluate membrane system performance and identify ZwitterCo SF process parameters for produced water treatment. Initial treatment runs were conducted at less aggressive process parameter conditions and progressed to increasingly aggressive process parameter conditions as targets were met. Process parameters that were evaluated included 1) membrane flux and recovery, and 2) cleaning schedule and chemistry. More information on the optimization of these membrane process parameters is included in the following sections.

#### 2.1.4.1.1. Membrane Flux and Recovery Optimization

To evaluate the membrane performance capabilities, the pilot was operated at increasingly aggressive process parameter conditions. The initial pilot goals were to operate at 10 lmh flux, 95% recovery, and >95% uptime. These target process parameter conditions had been identified as achievable operating conditions that would make the ZwitterCo an economically advantageous desalination pretreatment option. Within several runs, it was evident that the pilot could easily achieve these goals, and more aggressive process parameter targets were pursued.

Two 168-hr and one 72-hr continuous operation tests were conducted at increasingly aggressive parameters (see Table 4). These tests were successful, and the SF pilot was able to hold consistent flux within the membrane operating specifications at the listed process conditions.

*Table 4: Piloted ZwitterCo Superfiltration Membrane Process Conditions*

<b>Flux</b>	<b>Crossflow Velocity</b>	<b>Recovery</b>	<b>Uptime</b>	<b>Cleaning Schedule</b>	<b>Validating Data</b>
10 lmh	12 cm/sec	99%	>95%	Daily water flushes. 2x MW/7 days	168-hr continuous run (Figure 2)
15 lmh	12 cm/sec	95%	>95%	1 water flush/7x days. 3x MW/7 days	168-hr continuous run (Figure 3)
17-20 lmh	16 cm/sec	99%	>95%	1x MW/day	72-hr continuous run (Figure 4)

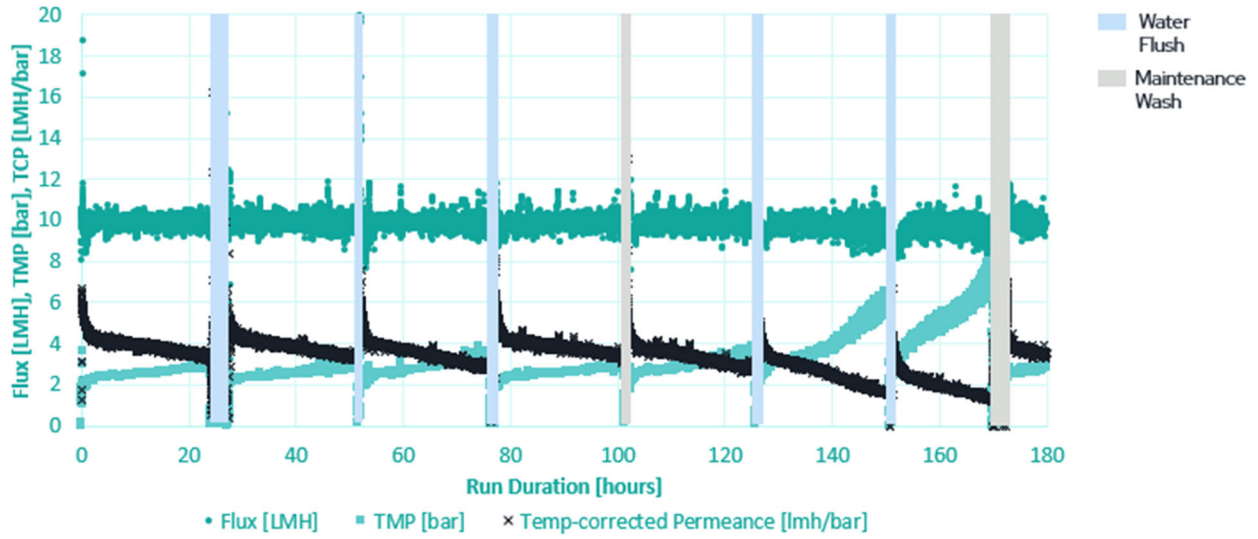

Figure 2: 168-hour continuous run at 10 lmh, 99% recovery, and uptime of >95%

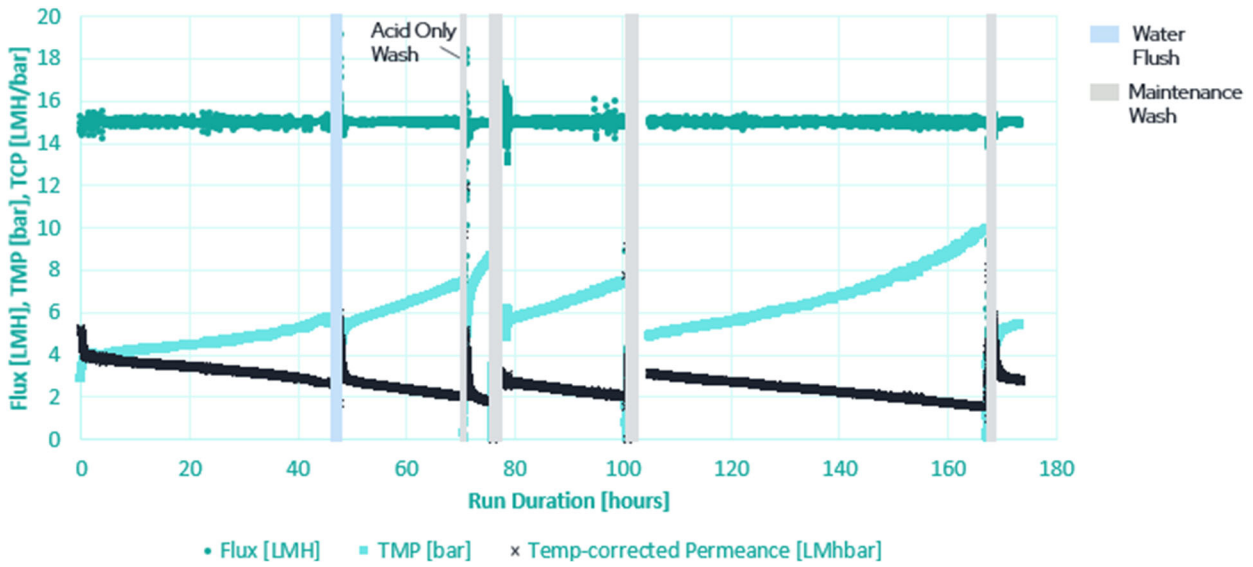

Figure 3: 168-hour continuous run at 15 lmh, 95% recovery, and uptime of >95%

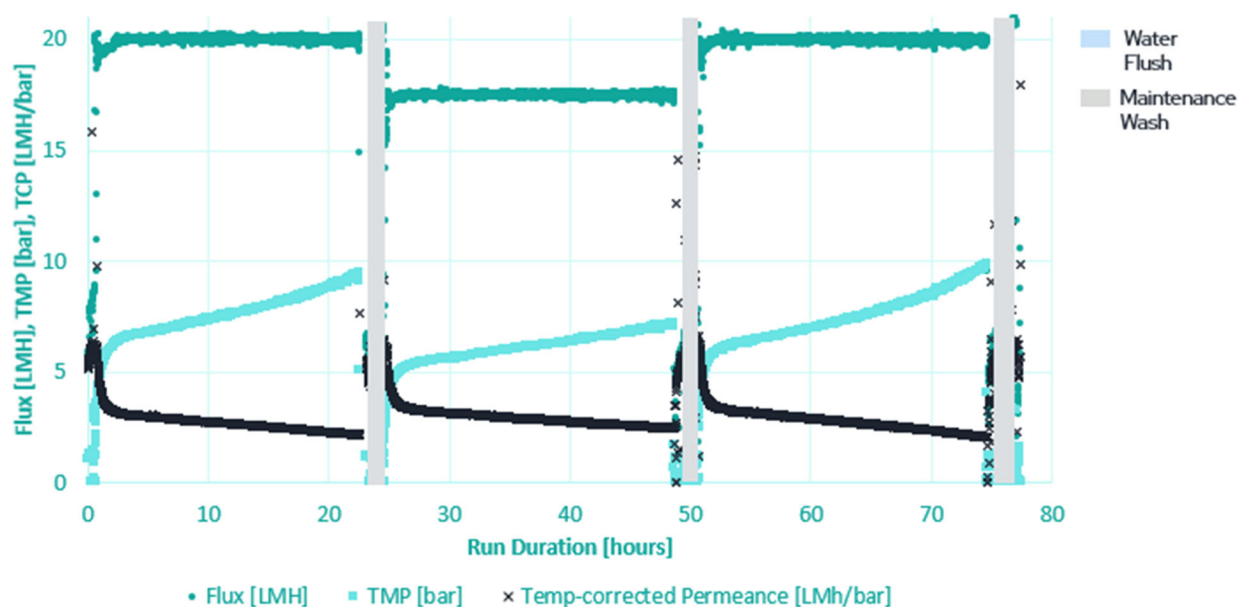

Figure 4: 168-hour continuous run at 17-20 lmh, 99% recovery, and uptime of >95%. The elevated oil concentration study was conducted during the last 48 hours of this run.

### 2.1.4.1.2. Membrane Cleaning Optimization

Optimization of the membrane cleanings showed that the ZwitterCo membranes are highly resilient to fouling and recovered their original permeance throughout the course of the pilot testing. Typical cleans consisted of either water flushes or short ( $\leq 1$  hr) MWs, and procedures for these cleans are described in Table 5.

Table 5: Typical ZwitterCo SF Membrane Cleaning Procedures

Wash Type	Steps	Water Temperature
Water Flush	10 min water flush with tap water	Ambient
Maintenance Wash	10 min water flush with tap water 15 min hydrochloric acid wash (pH 2) 10 min water flush 15 min sodium hydroxide and bleach wash (pH 12 and 100 ppm as Cl <sub>2</sub> ) 10 min water flush	Ambient

Two different cleaning schedules were demonstrated during the pilot: time-driven cleaning and performance-driven cleaning. The 10 lmh 168-hr test was conducted with time-driven cleaning schedule, and the 15 lmh 168-hr test was conducted with performance-driven cleaning schedule. The time-driven cleaning schedule incorporated a daily water flush until the membrane permeance neared 1 lmh/bar at the end of a day, and then a MW was conducted. One of the important findings from this pilot was that a simple 15-minute ambient temperature water flush

provided adequate cleaning to maintain the ZwitterCo superfiltration membrane performance for multiple days in a row (see Figure 2).

The performance-driven cleaning schedule postponed cleans until it was expected that the membrane permeance would reach the 1 lmh/bar cutoff at the end of the workday, and then a water flush or MW clean was conducted. At 15 lmh, the pilot showed that the ZwitterCo membranes were typically able to operate for 48 continuous hours after a MW. Showing that ZwitterCo membranes may not require daily cleans for produced water treatment gives operators more operating versatility and shows that ZwitterCo membrane may require less maintenance than other types of membranes.

### **2.1.4.1.3. Process Parameter Optimization Conclusions**

Key findings from the optimizing operating parameter testing included:

- The ZwitterCo pilot system successfully operated for >600 hours during the pilot duration including two 168-hr tests.
- ZwitterCo membranes successfully operated at 20 lmh flux (11.8 gfd) rather than the initial testing expectation of 10 lmh (5.9 gfd). The improved flux results reduced the modeled capital cost of a ZwitterCo membrane system since less membrane area was needed to treat the same feed water flow.
- ZwitterCo membranes successfully operated at 99% recovery rather than the initial expectation of 95% recovery. The higher recovery reduced the modeled operating costs by reducing the concentrate handling and disposal costs.
- The piloting results showed that the SF system successfully operated at higher operating flux and higher recovery which lowered the expected capital and operating cost of a ZwitterCo superfiltration system from \$0.14/bbl feed to \$0.11/bbl feed.
- The piloting validated the assumption that ZwitterCo membranes could operate at >95% uptime (less than one hour of cleaning per day). In the TEA, this does not necessarily add to the calculated downtime since redundancy can be built into the system such that cleaning does not contribute to downtime. The extent to which downtime is mitigated by redundancy is a matter of economics.
- Membrane cleaning was optimized, and it was found that when the SF system operated at 10-15 lmh flux, water only flushes were very successful in recovering membrane permeance. In addition, the membrane fouling was so low that the membranes could operate for multiple days without water flushes or chemical cleans. These results lower the expected operating cost of a ZwitterCo superfiltration system since less chemicals may be required for system operation. Additionally, other membrane manufacturers typically require daily chemical cleans to recovery membrane permeance. The relatively low cleaning requirements of the ZwitterCo membranes can be a key market differentiator.

### **2.1.4.2. Water Quality Results**

The ZwitterCo membrane was also evaluated with respect to the permeate quality. The key process parameters for this pilot were to achieve average permeate quality of < 1 SDI, < 10 ppm O&G as HEM, and < 2 ppm iron. In addition, the permeate quality and membrane rejection were evaluated with respect to other contaminants of interest in produced water treatment. The initial permeate quality was evaluated after a couple weeks of operation to guide pilot process modifications. While the average permeate quality was within the HEM target concentration and the turbidity was quite low (<0.3 NTU), the initial average permeate SDI and iron concentration exceeded the target concentrations at 5.3 SDI and 26.6 mg/L total iron (see Table 6). The high SDI and was surprising because of the low turbidity and general clarity of the permeate (see Figure 5). The analytical results showed that about 100% of SF feed iron was in the dissolved form. As a result, it was hypothesized that the dissolved iron was precipitating after superfiltration which caused the high SDI.

Table 6: ZwitterCo SF Pilot Initial Average SF Feed and Permeate Water Quality (without Aeration)

Sample Location	SDI	O&G as HEM [mg/L]	Iron (Total) [mg/L]	Turbidity [NTU]
SF Feed	N/A	ND	28.7	26.9
Permeate	5.3	ND	26.6	0.28
Rejection	N/A	N/A	7%	99%

Note: Averaged results were calculated based on the average value of the reported results from the analytical lab. If analytical lab reported “non-detect” for an analyte, the average of the values above the detection limit was calculated. The non-detect samples were accounted for by indicating that the true average is less than the average calculated based on the available information.



Figure 5: Picture of the raw produced water, SF feed (cartridge filtered produced water), permeate, and concentrate from left to right.

To address the high SDI and iron permeate concentrations, an investigation into the benefit of including iron pretreatment was conducted. Additionally, the O&G concentration in the feed water was relatively low in comparison to what is expected in typical produced waters (~100

ppm O&G). As a result, an elevated oil concentration test with a spike of RB TrueSyn 200i into the produced water was conducted to evaluate the ZwitterCo SF membrane at higher O&G concentrations. Results from these two studies and an evaluation of the ZwitterCo SF membrane system as a pretreatment system to downstream desalination technologies are reported in the sections below.

### **2.1.4.2.1. Iron Reduction Study**

The ZwitterCo SF membranes are designed to remove particulates >1 kDa in diameter but will not provide much barrier to dissolved compounds. To evaluate why the ZwitterCo permeate SDI and iron concentrations exceeded the target goals, it was important to determine whether 1) there were membrane integrity issues, or 2) the constituents that were passing through the membrane were in the dissolved state and should not be expected to be removed by the ZwitterCo membranes.

To determine whether there were membrane integrity issues, a membrane integrity test was conducted by using a tracer compound and evaluating the membrane tracer rejection. The membrane integrity test showed no degradation of the membrane, and the membrane rejection of the tracer compound was similar to that of the membrane prior to pilot deployment. Once membrane integrity had been confirmed, additional measures to address the high permeate SDI and iron concentration were implemented.

Review of the feed water quality analytical data showed that the produced water had a very high concentration of iron and that most of this iron was in dissolved form (about 100%). It was hypothesized that dissolved iron was passing through the membranes and precipitating after superfiltration treatment which caused the high SDI. The low raw produced water oxidation reduction potential (ORP) measurements (average -126.9 mV ORP) supported the analytical results showing a high ratio of dissolved to total iron in the raw produced water. To test whether precipitating the iron could increase iron rejection by the superfiltration system, a basic aeration oxidation pretreatment system was implemented.

The aeration oxidation pretreatment consisted of adding a small aeration tank upstream of the prefilter to increase the ORP and cause iron to precipitate. The aeration tank was sized to have 2.8 hours of detention time with two aquarium pumps that each delivered a max airflow rate of 64 gal/hr air. The aeration system increased the produced water to -27.1 mV ORP, improved total iron rejection, and decreased the total iron permeate concentration to <5.7 mg/L (see Table 7). In addition, the permeate SDI dropped to 1.8. The great improvement in total iron concentration and SDI indicated that much of the SDI fouling was due to dissolved constituents, especially iron, passing through the membranes as expected. Next steps towards reaching the water quality goal of < 1 SDI and < 2 mg/L total iron could focus on optimization of an oxidative pretreatment step that more fully oxidizes the iron for SF removal.



Table 7: Average ZwitterCo SF Feed and Permeate Water Quality (with Aeration)

Sample Location	SDI	O&G as HEM [mg/L]	Iron (Total) [mg/L]	Turbidity [NTU]
SF Feed	N/A	ND	11	100.4
Permeate	1.8	ND	<5.7	0.16
Rejection	N/A	N/A	>48%	99.8%

### 2.1.4.2.2. Elevated Oil Concentration Study

The O&G concentration of the produced water available for this pilot test had relatively low concentration compared to typical produced water O&G concentrations. The produced water O&G concentration for this pilot test was below the analytical lab detection limit of 5.6 mg/L HEM, and typical produced water O&G concentrations are around 100 mg/L. Since one of the ZwitterCo SF membrane benefits is high tolerance to O&G and high O&G rejection, a spike of RB TrueSyn 200i, a synthetic carrier oil, was added to the raw produced water to evaluate ZwitterCo membrane oil tolerance and rejection.

The elevated oil concentration study was conducted by spiking the TrueSyn into the pilot system feed break tank. Prior to adding the TrueSyn to the break tank, the oil was mixed vigorously into a small vessel of the produced water to disperse the oil as much as possible. The oil was added for a target feed concentration of 150 mg/L HEM, but due to the difficulty dispersing the oil, the produced water feed oil concentration was about half that (see Table 8). The pilot was successfully operated for 48-hours at the conditions in Table 9.

Table 8: Elevated Oil Concentration Study Water Quality

Sampling Location	O&G as HEM [mg/L]
Oil Spiked Produced Water Feed	85.5
SF Feed	28.1
Permeate	ND
SF Rejection	Full Rejection

Table 9: ZwitterCo Pilot Process Conditions for the Elevated Oil Concentration Study

Flux	Crossflow Velocity	Recovery	Uptime	Cleaning Schedule	Validating Data
17-20 lmh	16 cm/sec	99%	>95%	1x MW/day	48-hr continuous run (Figure 4)

The elevated oil concentration study showed that the ZwitterCo SF membranes had full rejection of oil and that the permeate oil concentration was below the detection limit of the analytical lab

(<5.26 mg/L HEM) (See Table 8). This permeate quality was well below the permeate water quality goal of <10 mg/L HEM. This test demonstrated that the ZwitterCo SF membrane has high rejection of O&G compounds, even at elevated O&G concentrations and when operated at 99% recovery and 17-20 lmh.

### 2.1.4.2.3. ZwitterCo SF Permeate Quality for Produced Water Treatment Contaminants of Interest

In addition to meeting the key permeate quality performance indicators for downstream desalination technologies, the ZwitterCo SF permeate water quality and membrane rejection was evaluated with respect to produced water treatment contaminants of interest. The contaminants of interest included a suite of inorganic compounds, broad organic compound characterizations, and volatile organic compounds. Water quality characterizations of the raw produced water, SF feed, permeate, and concentrate are located in Table 10.

The ZwitterCo membrane is a SF membrane that is designed to remove components >1 kDa but is expected to have low rejection of salts and ionic components. The analytical results showed that, as expected, the ZwitterCo membranes had high turbidity rejection and low rejection of other compounds that can be dissolved. The results indicate that the final effluent quality must be considered when designing a produced water treatment system and that additional treatment beyond the ZwitterCo SF membranes may be required.

Table 10: Average Water Quality at ZwitterCo Superfiltration Sampling Locations and Membrane Rejection

Parameter	Units	Raw Produced Water	SF Feed	Permeate	Concentrate	SF Rejection
Oil & Grease (Hexane Extr)	mg/L	ND	ND	ND	12.7	N/A
TPH - Oil & Grease	mg/L	ND	ND	ND	ND	N/A
Barium	mg/L	2.5	2.3	2.7	2.7	N/A
Boron	mg/L	39.8	48.6	52.3	46.2	N/A
Calcium	mg/L	7,152.5	5,716.7	7,272.5	7,484.0	N/A
Copper	mg/L	ND	ND	0.3	ND	N/A
Iron, Total	mg/L	17.8	25.7	18.8	47.7	27%
Magnesium	mg/L	1,072.8	814.0	1,035.5	1,095.0	N/A
Phosphorus	mg/L	5.4	3.2	3.6	9.1	N/A
Potassium	mg/L	832.3	689.0	688.0	883.2	0%
Silicon	mg/l as SiO2	9.9	10.9	11.8	11.6	N/A
Sodium	mg/L	30,050.0	30,100.0	35,550.0	35,360.0	N/A
Sulfur	mg/L	230.5	216.7	248.0	268.8	N/A
Zinc	mg/L	ND	ND	2.5	ND	N/A
Barium, Dissolved	mg/L	2.8	2.7	2.7	2.8	N/A

Boron, Dissolved	mg/L	47.7	57.7	47.3	47.6	N/A
Calcium, Dissolved	mg/L	8,197.5	6,643.3	7,548.0	7,728.0	N/A
Copper, Dissolved	mg/L	ND	ND	0.5	ND	N/A
Iron, Dissolved	mg/L	20.5	25.5	3.4	29.9	87%
Magnesium, Dissolved	mg/L	1,239.5	601.3	1,132.6	820.9	N/A
Phosphorus, Dissolved	mg/L	ND	ND	5.0	7.3	N/A
Potassium, Dissolved	mg/L	876.0	728.7	808.6	838.6	N/A
Silicon, Dissolved	mg/l as SiO <sub>2</sub>	11.7	12.7	15.1	12.9	N/A
Sodium, Dissolved	mg/L	36,650.0	32,366.7	42,600.0	42,180.0	N/A
Sulfur, Dissolved	mg/L	158.1	229.7	233.0	196.5	N/A
Zinc, Dissolved	mg/L	ND	ND	2.5	ND	N/A
Alkalinity, Bicarbonate	mg/L	178.0	168.7	166.2	205.2	1%
Alkalinity, Carbonate	mg/L	ND	ND	ND	ND	N/A
Dissolved Solids	mg/L	137,250.0	115,000.0	141,750.0	129,600.0	N/A
Suspended Solids	mg/L	77.3	61.9	N/A	421.6	N/A
Bromide	mg/L	681.0	548.0	654.8	639.4	N/A
Sulfate	mg/L	643.3	616.3	637.8	661.4	N/A
Chloride	mg/L	90,000.0	76,566.7	86,860.0	86,240.0	N/A
Ammonia Nitrogen	mg/L as N	453.3	374.3	425.2	434.6	N/A
Kjeldahl Nitrogen, TKN	mg/L as N	288.4	356.0	361.6	347.8	N/A
COD	mg/L	9,090.0	7,093.3	6,404.0	5,644.0	10%
BOD	mg/L	420.8	325.8	310.9	414.4	5%
DOC	mg/L	64.5	42.3	60.8	104.4	N/A
TOC (Total Organic Carbon)	mg/L	73.4	59.9	47.7	130.4	20%
Ethylbenzene	mg/L	0.065	0.026	0.004	0.003	85%
Toluene	mg/L	0.5	0.3	0.2	0.1	31%
Xylenes, Total	mg/L	0.1	0.2	0.2	0.0	N/A
Benzene	mg/L	0.2	0.5	0.6	0.3	N/A
Acetic Acid	mg/L	45.3	33.5	34.8	84.0	N/A
Formic Acid	mg/L	263.5	180.5	55.2	500.0	69%

Note: Averaged results were calculated based on the average value of the reported results from the analytical lab. If analytical lab reported “non-detect” for an analyte, the average of the values above the detection limit was calculated.

#### **2.1.4.2.4. Water Quality Testing Conclusions**

Key findings from the pilot testing are listed below:

- The ZwitterCo SF system had 99.6% turbidity removal and average permeate quality of < 0.3 NTU turbidity
- The ZwitterCo pilot permeate O&G concentration was always below the O&G reporting limit and this permeate quality met the pilot target permeate water quality goals of < 10 mg/L O&G as HEM even with elevated oil concentration testing.
- The ZwitterCo pilot did not achieve the pilot target permeate water quality goals of < 1 SDI and < 2 ppm iron. The high permeate iron concentration and high SDI is believed to be due to high dissolved iron concentration in the produced water. The ZwitterCo pilot is not expected to remove dissolved constituents, so it is likely that additional water treatment is necessary to reduce the iron concentration if these water quality goals are required. Rudimentary testing of aeration prior to the SF step showed dramatic improvement in SDI and iron removal and is indicative that properly designed aeration or otherwise oxidation of the feed may achieve these permeate water quality goals.

#### **2.1.5. Pilot Testing Overall Conclusions**

The pilot testing demonstrated that the ZwitterCo membrane successfully treated the Permian Basin gun-barrel separated produced water and could be a good pretreatment technology to a desalination technology (e.g. membrane distillation, reverse osmosis, evaporative technologies). This pilot test demonstrated that the ZwitterCo SF technology has moved from the TRL 4 to the TRL 5 state by accomplishing the following:

- Produced water was successfully treated using a SF system in which all the basic technological components are integrated so that the system configuration is similar to (matches) the final application in almost all respects. Pilot testing was done in a simulated environment with actual wastewater for treatment.
- Successful operation of the pilot was supported by results from the pilot testing and analysis between the pilot environment and eventual operating system.
- The fidelity of the pilot system was in-line with TRL 5 expectations, and the tested system was almost prototypical.

Next steps for developing ZwitterCo's SF technology to TRL 6 include pilot testing in the relevant environment and further development of the membrane skids as an operational system.

### **3. TEA Discussion**

The general consensus from industry interviews conducted by the project team is that a fully integrated treatment process will be economically viable in the Permian Basin if it is able to achieve treatment costs below \$2/bbl. This aligns with the New Mexico Produced Water

Research Consortium’s (NMPWRC) Technology Screening Criteria which states that desalination pretreatment technology cost targets are \$0.10-0.20/bbl and desalination technology targets are \$1.00-2.00/bbl.

The strategy used for estimating costs of the pre-treatment membrane followed by desalination is as follows. It is assumed that PES, ceramic, and ZwitterCo membranes are barrier technologies. As such they remove all contaminants that would cause fouling and flux decline in the desalination technologies (e.g. RO, MVC, MD, OARO). These desalination technologies are in the development stage for shale produced water treatment. Thus, there is not much data available. Therefore, the OPEX and CAPEX for each desalination technology was estimated on the basis of seawater service in terms of fouling tendency (i.e. relatively clean feed water quality compared to shale produced water). Estimating the costs for desalination technology leaned heavily on well-known costs for seawater desalination. The cost required to bring shale produced water up to a high degree of cleanliness is borne by the pretreatment membrane technologies in their OPEX.

The initial cost estimate was based on laboratory measurements and best-estimate scale-up calculations. These values, referred to as “original base case” are given in the table below.

*Table 11: Original parameters versus pilot parameters and associated CAPEX*

Case	Flux (lmh)	Recovery (%)	CAPEX (\$/(bbl day))
Original Base	10	95	0.06
Pilot	20	99	0.05

### 3.1. Current Practices & Typical Water Quality

Produced water practices in the Permian Basin are dominated by deep well disposal operations. Further details on the source and demand centers, typical water quality, treatment practices and cost structures are given in Appendix B.

### 3.2. Pretreatment

Pretreatment costs were calculated on the basis of CAPEX (membrane cost, auxiliary equipment), and OPEX (chemical, electricity, maintenance, replacement parts, etc). The pilot study demonstrated that the ZwitterCo membrane could be operated at a steady flux of 20 lmh. This was higher than the anticipated flux (10 lmh). The scope of the pilot study did not include testing of any other pre-treatment technologies such as DGF, WSF, PES UF, ceramic UF. Those technologies are relatively well known, and their performance has been published in the open literature.

As already mentioned, there are three important factors that are commonly used to calculate CAPEX and OPEX in terms of (a) present value of money, (b) lump sum cost of capital, and (c) unit cost (amortized CAPEX plus OPEX per unit volume of water). These factors are:

1. CCF (Cost Capacity Factor) – this allows scale-up and scale-down of cost information.
2. CEPCI (Chemical Engineering Plant Cost Index) – this allows for the variable cost of equipment over time,

3. CRF (Capital Recovery Factor) – this allows for the calculation of per-barrel costs of capital.

The details of these calculations are given in the TEA spreadsheet located in Appendix A.

Table 12: OPEX and CAPEX of desalination pretreatment alternatives

\$/bbl	OPEX	CAPEX	Total
DGF & WSF	0.03	0.02	0.05
ZwitterCo UF (SF)	0.06	0.05	0.11
PES UF	0.23	0.06	0.29
Ceramic UF	0.09	0.40	0.50

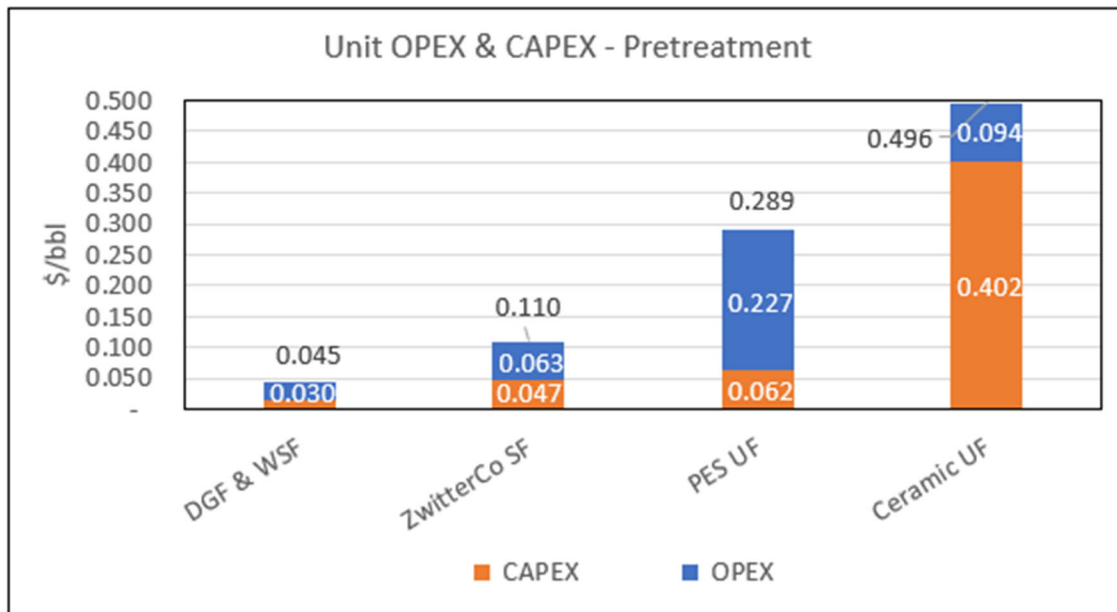

Figure 6: Pretreatment Technology Cost Comparison. All costs are given in units of \$/bbl of water delivered.

Figure 6 gives the CAPEX and OPEX in units of \$/bbl water delivered. In typical filtration processes, water delivered excludes reject water (also referred to as concentrate). As tabulated in Table 12 and plotted in Figure 6, evaluating the pretreatment technologies in isolation we see that:

- DGF and WSF pretreatment is the lowest total cost overall at \$0.05/bbl,
- ZwitterCo SF at \$0.11/bbl,
- standard polymeric PES UF at \$0.29/bbl,
- and Ceramic UF at \$0.50/bbl.

Only ZwitterCo SF and DGF/WSF fall below the \$0.20/bbl NMPWRC cost target for pretreatment viability.

While the DGF/WSF pretreatment is the lowest cost overall, it is not a barrier filtration technology and cannot therefore be used to protect the desalination technologies. The effluent of DGF/WSF will contain residual TPHs. The steady-state range of TPH is about 5 to 25 mg/l. Not only is this high for desalination protection in steady-state operation but the main problem the DGF/WSF helps to solve is the devastating impact of excursions. Typical oilfield water treatment systems often experience excursions of many hundreds of ppm of oil. During an excursion the oil and oily solids will suddenly increase dramatically. This is due to a number of possible upstream process upsets. These excursions will be mitigated to a great extent by the DGF/WSF system providing partial protection for all downstream processes. A further benefit of DGF/WSF is the potential to use them to oxidize and precipitate iron as a first step to removal.

Additional details for the technology costs are provided here. As shown in Table 12, breaking down total pretreatment costs into the upfront CAPEX and ongoing OPEX, one can see that the ZwitterCo SF CAPEX costs at \$0.05/bbl water are 17% lower than the CAPEX of standard PES UF at 0.06 \$/bbl water. Ceramic UF has significantly higher CAPEX than all other options. This is due to the high cost of ceramic membrane monoliths and the low packing density of its tubular configuration compared to spiral wound polymeric membranes. Thus, the ZwitterCo SF membrane is the only pretreatment technology that meets the cost criteria and provides adequate treatment.

Table 13: Details of OPEX model

OPEX Category (\$/bbl)	DGF + WSF	ZwitterCo SF	PES UF	Ceramic UF
Membrane replacement	-	0.016	0.167	0.031
Labor	0.013	0.027	0.027	0.039
Electricity	0.001	0.006	0.003	0.003
Misc., maintenance	0.001	0.008	0.008	0.008
Chemicals	0.014	0.006	0.022	0.012
<b>Total OPEX (\$/bbl)</b>	<b>0.030</b>	<b>0.063</b>	<b>0.227</b>	<b>0.094</b>

An additional benefit of ZwitterCo SF is in savings associated with OPEX. Pretreatment OPEX costs are broken down in Table 13 above. The OPEX for PES UF is much greater than that for ZwitterCo SF. At a high level, the areas where ZwitterCo membranes realize OPEX savings relative to standard polymeric are on membrane replacement costs and chemical cleaning costs. ZwitterCo membrane lifetime is expected to be between 2-5 years and an average of 3 years was used for this analysis. Standard polymeric membranes have expected lifetimes of less than a year for operation with produced water and a 6-month lifetime was modeled. During the pilot study in which live produced water was fed to the ZwitterCo SF membrane, no integrity problems were identified. Visual inspection did not show swelling, delamination, or signs that the membrane has suffered a tear in the fabric. Nevertheless, the pilot was only in service for less than two months. Much longer extended evaluations will be required to specify a membrane lifetime in this

service. Ceramic membranes, the most robust membrane in terms of durability and chemical tolerance, have expected lifetimes up to 10 years and were modeled as such in the analysis.

Chemical cleaning frequencies and chemical demands are also anticipated to be lower for ZwitterCo compared to the other membranes. Given the resistance of ZwitterCo's membranes to organic fouling, maintenance wash frequency was modeled as one hour every 24 hours using standard cleaning chemicals like caustic, hydrochloric acid, and bleach. This cleaning frequency was demonstrated during the pilot study where maintenance wash frequency was tested on actual produced water.

Standard PES membranes were modeled to run a 3-hour CIP every 12 hours given their high propensity for fouling and difficulty recovering membrane performance. CIPs typically are > 3 hours duration and include a mixture of steps using standard, low-cost cleaning chemicals like caustic and hydrochloric acid as well as more expensive biocidal agents, like DBNPA, in lieu of chlorine-based biocides. Ceramic membranes were modeled to run a 3-hour CIP every 24 hours with chemical enhanced backwashing (CEBs) happening once every 2 hours for a duration of 15 min, as is standard practice in its implementation within produced water treatment.

ZwitterCo SF electricity OPEX is higher than the other membrane technologies due to its tighter pore size (approximately 1 nanometer) and molecular weight cutoff (approximately 1,000 Da) which requires a higher baseline trans-membrane pressure to drive the filtration, resulting in an electricity demand of \$0.006/bbl compared to \$0.003/bbl for the ceramic and PES membranes.

### 3.3. Integrated Treatment Processes

Table 14 Integrated process treatment costs

Desalination Step:	Membrane Distillation (MD)		Mechanical Vapor Compression (MVC)		Osmotically Assisted Reverse Osmosis (OARO)	
	ZwitterCo SF	PES UF	ZwitterCo SF	PES UF	ZwitterCo SF	PES UF
Total Cost (\$/bbl)	1.34	1.83	1.60	2.12	4.41	5.21

To this point in the discussion, pretreatment technologies have been evaluated in isolation, without consideration of other unit operations in the treatment system. Next, fully integrated treatment trains were evaluated. Based on initial technical and economic analysis, two pretreatment technologies (ZwitterCo SF and PES UF) and three desalination technologies (MD, MVC, and OARO) were considered to be viable (see Table 14 above).

RO is excluded based on its inability to handle the high salinities of the produced water found in the Permian basin. Ceramic UF is excluded based on its significantly higher treatment costs versus the polymeric alternatives.

Altogether, six combinations were analyzed as shown in Table 14. In all combinations considered, DGF and WSF are assumed as the initial treatment ahead of the SF or UF pretreatment for reasons given above which include their common use in the industry, relatively low cost, and positive impacts on membrane lifetime. In order to penalize treatment trains with lower total recoveries of desalinated water, treatment costs were calculated on a per barrel of



desalinated water basis. The results are summarized in Table 14 above and show that the lowest total treatment cost is the ZwitterCo SF + Membrane Distillation process at \$1.34/bbl.

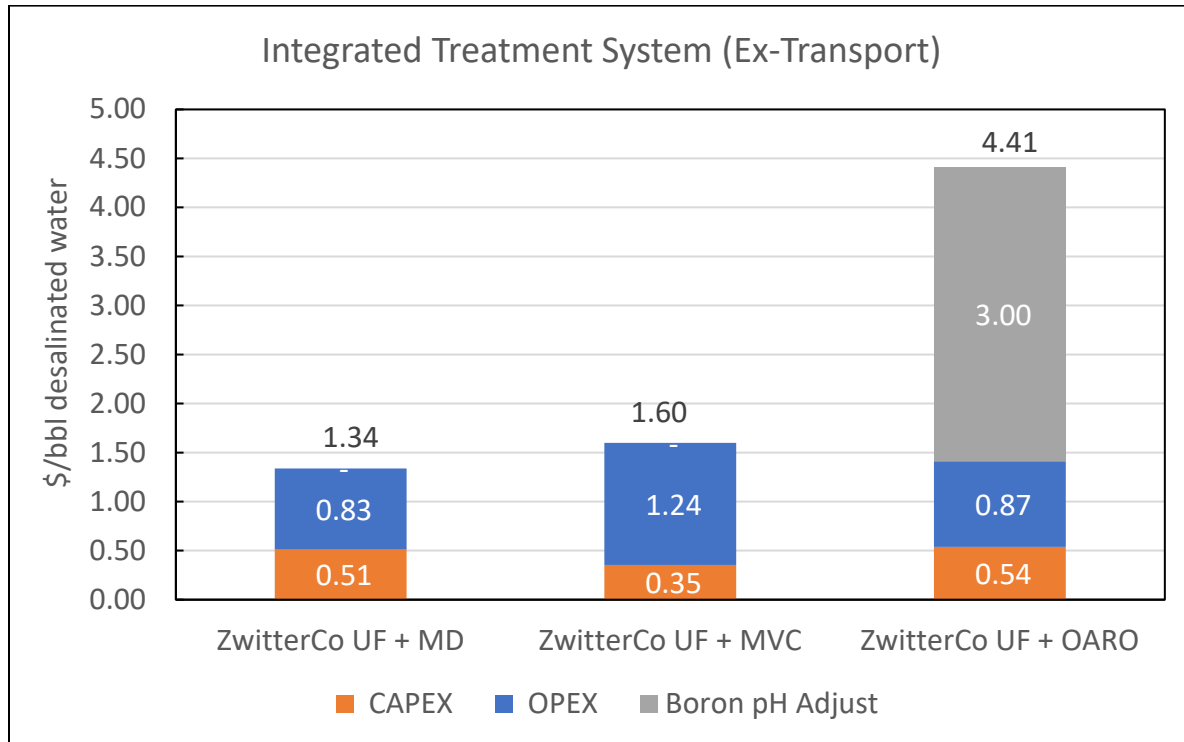

Figure 7: Cost of integrated treatment system

Breaking down the treatment costs of the integrated processes incorporating ZwitterCo SF pretreatment into CAPEX and OPEX, one can see that the ZwitterCo/MD process has a higher upfront capital cost than the ZwitterCo/MVC; however, the overall cost for ZwitterCo/MD is lower given the significantly higher operational cost of ZwitterCo/MVC, in part driven by the high electrical demand and maintenance costs of the thermal MVC process.

The OARA process would be a competitive option if not for the presence of high levels of boron found in Permian produced water. Boron concentrations exceed 200 mg/l on average in the Permian and would need to be reduced to less than 2 mg/l in order to be used for most beneficial reuse applications. While boron is rejected in the MD and MVC desalination processes, it is not rejected by reverse osmosis membranes at the natural pH of produced water, around pH 6.5, and would require chemical adjustment up to a pH of 11 or higher to be removed. The cost of this pH adjustment alone, \$3.00/bbl, is higher than either alternative desalination process in totality. It is thus not considered a viable option.

As a result of this technoeconomic analysis, the final recommended integrated produced water reuse system incorporates dissolved gas flotation, walnut shell filtration, ZwitterCo superfiltration, and membrane distillation. A process flow diagram of this treatment train is included in Figure 8 below.

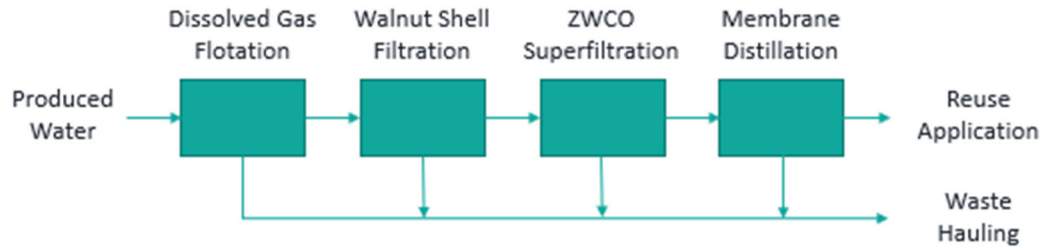

Figure 8: Recommended integrated produced water reuse treatment train

### 3.4. Beneficial Reuse Applications

The current practice that the majority of the primary oil and gas producers operating in the region take for handling produced water is deep-well injection into a saltwater disposal (SWD) well with minimal treatment. Some midstream companies are partaking in higher levels of water treatment and reuse within their own sites, but they are not carrying out significant reuse beyond their own sites. The beneficial reuse opportunities described below are largely theoretical for the region due to lack of regulation supporting their implementation.

Opportunities for beneficial reuse of the desalinated produced water in the Permian Basin were evaluated based on four main criteria:

1. *Water Demand* - the regional amount of water required by the application. Water demand of 1,000,000 barrels of water per day (BWPD) or more is considered high, between 100,000 and 1,000,000 BWPD moderate, and under 100,000 BWPD low.
2. *Proximity to Pipeline and Well Activity* – the end-use application’s distance from current water midstream pipelines, treatment centers, or concentrated well activity. Locations within 20 miles of oil and gas or midstream operations is considered high proximity, more than 20 miles away moderate proximity, and diffuse end-use applications which require dispersed water delivery (e.g. trucking for road spreading) or lack current distribution infrastructure (e.g. rangeland watering) are considered low proximity.
3. *Risk Profile* – the actual or perceived risk to human health. Applications with direct human consumption of desalinated produced water were considered high risk, indirect consumption, for example via agricultural food watering, moderate risk, and industrial applications avoiding human consumption altogether, low risk.
4. *Need* – the need of alternative sources of water for the application considering its current water sourcing practices and direct feedback from end-users on utilizing desalinated produced water. Applications currently utilizing highly stressed water sources or those expressing a desire to use desalinated produced water as an alternative or supplemental source are considered high need, those in which end-user opinions on utilizing desalinated produced water were split or as of yet unknown are considered moderate need, and those where the end-use is considered a low priority (e.g. road spreading) or in which end-users have expressed disinterest in using treated produced water are considered low need.

Beneficial reuse applications in the agricultural, industrial, and municipal sectors were considered and include crop irrigation, surface water augmentation, rangeland watering, power

plant cooling water, potash mining extraction, dust-control road spreading, and municipal water use. The results of this evaluation are highlighted in Table 15 below.

Table 15: Beneficial reuse opportunities

Status	End Use	Sector	Water Demand	Proximity to Pipeline/Activity	Risk Profile	Need
High Feasibility	Irrigation	Agriculture	High	High	Moderate	High
	Surface Water	Agriculture	Moderate	High	Moderate	High
	Power Plants	Industrial	Moderate	High	Low	Moderate
Low Feasibility	Rangeland	Agriculture	High	Low	Moderate	Moderate
	Mining	Industrial	Moderate	High	Low	Low
	Road Spreading	Municipal	Low	Low	Low	Low
	Municipal	Municipal	High	Moderate	High	Moderate

### 3.4.1. High Feasibility Applications

Agriculture makes up over 50% of water demand in both Texas and New Mexico. Three major counties in the Permian’s Delaware sub-basin—Lea, Eddy, and Reeves counties—each consume between 2-4 million BWPD for agricultural use. Significant cropland acreage can be found within 20 miles of current midstream pipeline infrastructure and well activity, including irrigation districts like the Carlsbad Irrigation District (25,000+ acres using 800,000 BPWD). Local crops include food crops like pecans and wheat; animal feed crops such as alfalfa; and non-food crops like cotton. The risk profile of using desalinated produced water for irrigation is considered moderate given that it may be difficult or impossible to isolate food versus non-food crops in water distribution and that even non-food crops may have indirect human health impacts such as alfalfa’s use as feedstock for animals raised for human consumption or cotton’s dermal exposure in clothing and home goods. Despite this, however, there is precedent for irrigating even food crops with produced water such as in California’s Central Valley and recent human health and toxicology studies that have confirmed that this practice is safe (Redmon, 2020). The need for alternative water sources is considered to be high given the arid region and reliance on depleting groundwater sources and Pecos River water diversion. In fact, the Carlsbad Irrigation District has brought lawsuits against regional water users over misuse of water rights and impacts on its own ability to draw water, a testament to the water-stress felt by the region and its agricultural sector. The ions of primary concern when considering reuse in crop irrigation are

chloride, sodium, and boron. Please see Table 16 below regarding guidelines for water quality for irrigation (Ayers and Westcot, 1985).

Table 166: Guidelines for Interpretations of Water Quality for Irrigation

Potential Irrigation Problem		Units	Degree of Restriction on Use		
			None	Slight to Moderate	Severe
<b>Salinity</b> (affects crop water availability) <sup>2</sup>					
	EC <sub>w</sub>	dS/m	< 0.7	0.7 – 3.0	> 3.0
	(or)				
	TDS	mg/l	< 450	450 – 2000	> 2000
<b>Infiltration</b> (affects infiltration rate of water into the soil. Evaluate using EC <sub>w</sub> and SAR together) <sup>3</sup>					
SAR = 0 – 3	and EC <sub>w</sub> =		> 0.7	0.7 – 0.2	< 0.2
= 3 – 6	=		> 1.2	1.2 – 0.3	< 0.3
= 6 – 12	=		> 1.9	1.9 – 0.5	< 0.5
= 12 – 20	=		> 2.9	2.9 – 1.3	< 1.3
= 20 – 40	=		> 5.0	5.0 – 2.9	< 2.9
<b>Specific Ion Toxicity</b> (affects sensitive crops)					
<b>Sodium (Na)</b> <sup>4</sup>					
	surface irrigation	SAR	< 3	3 – 9	> 9
	sprinkler irrigation	me/l	< 3	> 3	
<b>Chloride (Cl)</b> <sup>4</sup>					
	surface irrigation	me/l	< 4	4 – 10	> 10
	sprinkler irrigation	me/l	< 3	> 3	
<b>Boron (B)</b> <sup>5</sup>					
	Trace Elements (see Table 21)				
<b>Miscellaneous Effects</b> (affects susceptible crops)					
	<b>Nitrogen (NO<sub>3</sub> - N)</b> <sup>6</sup>	mg/l	< 5	5 – 30	> 30
	<b>Bicarbonate (HCO<sub>3</sub>)</b>				
	(overhead sprinkling only)	me/l	< 1.5	1.5 – 8.5	> 8.5
	pH		Normal Range 6.5 – 8.4		

Surface water augmentation, or the direct discharge of desalinated produced water to surface waters, is another high potential beneficial reuse application. The primary surface water candidate in the region is the Pecos River which runs from New Mexico into Texas and is the subject of a compact between the two states. This compact, known as the Pecos River Compact, requires the state of New Mexico to deliver water quantities to Texas tied to historical flows. New Mexico currently pumps groundwater into the river in order to meet the compact and, even so, is unable to satisfy the volume requirements in some years. For example, the 2019 shortfall averaged 200,000 BWPD less than that required by the Compact, for a total shortfall of 76 million barrels of water. The river is an ideal candidate for the Delaware sub-basin as it runs through significant areas of well activity and near current water midstream treatment centers. Treated produced water can be added at a range of locations along the waterway, minimizing transportation costs and enabling treatment at numerous locations throughout the basin. The risk profile of surface water augmentation is considered moderate given that there is no reasonable way to limit downstream water use once discharged into the Pecos; however, the blending of the desalinated produced water with fresh river water will provide an additional layer of protection on top of future National Pollutant Discharge Elimination System (NPDES) discharge quality

limits and regulations. Need for alternative water sources for Pecos River augmentation is considered high given the current reliance on groundwater pumping of water-stressed and depleting aquifers, legal battles over river water rights, and interest expressed by New Mexico's Office of the State Engineer. While New Mexico currently does not have discharge guidelines of treated produced water to surface water, the guidelines set by Pennsylvania and shown in Table 17 provide guidance for such water quality levels (Groundwater Protection Council, 2019).

Table 177: Water Quality Guidelines for Surface Discharge

Table 3-1: Pennsylvania WMGR123 Appendix A: Maximum Concentrations – Derived from Drinking Water Standards, Water Quality Standards for Rivers and Streams, and Typical Values Observed in Fresh Water Rivers and Streams (reformatted)

Constituent	Limit	Constituent	Limit
Aluminum	0.2 mg/L	Manganese	0.2 mg/L
Ammonia	2 mg/L	MBAS (Surfactants)	0.5 mg/L
Arsenic	10 µg/L	Methanol	3.5 mg/L
Barium	2 mg/L	Molybdenum	0.21 mg/L
Benzene	0.12 µg/L	Nickel	30 µg/L
Beryllium	4 µg/L	Nitrite-Nitrate Nitrogen	2 mg/L
Boron	1.6 mg/L	Oil & Grease	ND
Bromide	0.1 mg/L	pH	6.5-8.5 SU
Butoxyethanol	0.7 mg/L	Radium-226 + -228	5 pCi/L (combined)
Cadmium	0.16 µg/L	Selenium	4.6 µg/L
Chloride	25 mg/L	Silver	1.2 µg/L
COD	15 mg/L	Sodium	25 mg/L
Chromium	10 µg/L	Strontium	4.2 mg/L
Copper	5 µg/L	Sulfate	25 mg/L
Ethylene Glycol	13 µg/L	Toluene	0.33 mg/L
Gross Alpha	15 pCi/L	TDS	500 mg/L
Gross Beta	1,000 pCi/L	TSS	45 mg/L
Iron	0.3 mg/L	Uranium	30 µg/L
Lead	1.3 µg/L	Zinc	65 µg/L
Magnesium	10 mg/L		

The third high potential application identified is for use as cooling water at natural gas power plants in the region. There are four power plants in the northern Delaware sub-basin, all located in Lea county, of which a cluster of three are within 20 miles of a current midstream water pipeline. These three plants use an estimated 90,000 BWPd of cooling water combined. Another power plant located in Odessa Texas is less than 5 miles from current midstream operations and uses approximately 70,000 BWPd of cooling water. While the total water demand is the lowest of all the high potential end uses, the risk profile of this industrial application is also the lowest because of its lack of direct and indirect food chain impacts. The need for alternative water sources is considered moderate with assumed groundwater sourcing and a currently unknown level of industry interest. Overall, its low risk profile, moderate water demand, close proximity to oil and gas activity, and private industrial end-users make it an ideal candidate for initial implementation of beneficial reuse in the Permian.

### 3.4.2. Low Feasibility Applications

Rangeland is state or federally owned land that is leased for livestock grazing. Rangeland watering using desalinated produced water could be used to increase vegetation and thus the number of animals that can be supported per acre of land and a commensurate increase in the land's revenue generation. While the water demand is theoretically very high (over a third of land in New Mexico is rangeland), rangelands are dispersed and lack water distribution infrastructure. They currently rely on limited rainfall to support their vegetation growth. This makes it difficult and expensive for a centralized treatment plant to efficiently and cost-effectively deliver water to rangelands. An alternative option would be for smaller, decentralized

treatment facilities or mobile units to enable rangeland watering, however, these units would be significantly smaller and more expensive than centralized treatment facilities and are considered outside of the scope of this analysis.

Potash mining uses large amounts of freshwater to extract potassium salts and two operators, Intrepid and Mosaic, have facilities near well activity in the northern Delaware. Despite high water demand, proximity, and the low risk industrial end-use, these operators have longstanding priority water rights in the region and little interest in alternative sources. In fact, mining operations have been selling what they consider to be excess water from these rights to oil and gas operators for well completions and have expressed disinterest in utilizing desalinated produced water in their mining operations.

Road spreading would be the use of treated produced water for controlling dust on unpaved roads around the Permian basin. While human health risks are low, the water demand, proximity, and need for dust control are also considerably low. Roads are by nature dispersed and would require expensive truck transportation for water distribution. And taking Lea and Eddy counties of New Mexico as an example, their estimated combined 1,400 miles of dirt road would require only roughly 10,000 BWPD. In addition to this low demand, it's been demonstrated that road spreading for dust suppression actually benefits from the use of water with moderate amounts of salinity (e.g. 15,000 mg/l TDS) as opposed to the low salinity of the desalinated water or high salinity of the original produced water. It is therefore not considered a likely beneficial reuse opportunity.

Finally, municipal water use would be the direct or indirect use of desalinated produced water for municipal purposes, including drinking water, for example through aquifer recharge. Municipal water is the second highest water demand center in the region after agriculture. Despite this, the application has the highest risk to human health and would likely encounter strong skepticism and disapproval by local communities. It is therefore considered one of the least likely beneficial reuse opportunities. Instead, benefits of off-field reuse to municipal water supplies are expected to be indirect. As non-municipal end-users utilize desalinated produced water in place of freshwater, drawdown of municipal drinking water resources will be proportionally decreased, benefiting local communities while avoiding the risks associated with direct municipal reuse.

### **3.5. Remaining Challenges & Next Steps**

While there are many potential applications for beneficial reuse, the biggest remaining challenge to adopting this technology in produced water treatment in the Permian Basin is regulation. Current regulations do not allow for produced water to be reused in the manners evaluated, so there is little financial incentive for companies to invest in non-oilfield water reuse treatment schemes in the Permian Basin. As such, the near-term focus to advance the ZwitterCo membrane technology is to focus on other industries with oil-laden wastewaters that are better positioned to immediately adopt water reuse. It is likely that as industrial water reuse of oil-contaminated wastewater becomes generally more practiced, public perception and regulation will evolve to allow for produced water reuse.

From a technological standpoint, our pilot data indicates that iron control will likely be an ongoing challenge. ZwitterCo's SF membranes do not remove dissolved ions, and so reduced

iron (which is common in Permian Basin produced waters) will generally pass through the membrane. Our pilot demonstration addressed this problem with a pre-filtration aeration step, converting the dissolved iron to an oxidized form with much lower solubility. This dramatically increased the iron retention in the SF membrane. However, other iron treatment unit operations may also be possible. A techno-economic analysis specific to iron removal should be performed to determine the highest efficiency and lowest cost method to remove dissolved iron either before or after the SF treatment step.

A final remaining challenge will be validating the lifespan of the SF membranes. Our pilot project established a strong baseline of performance over 500 hours with no detectable signs of loss in performance. However, fully validating the lifespan of a ZwitterCo membrane in produced water service will require extended testing over several years. This data would likely not be fully determined until TRL 9-10.

ZwitterCo's plan for moving ahead in this application centers on maturing the technology while staying engaged in the evolving regulatory landscape. We will continue to enhance our value proposition by increasing performance and decreasing cost of our technology, including establishing case studies in other industrial water reuse applications. We will explore produced water reuse applications in other basins where the regulatory landscape may allow for beneficial reuse in a more immediate timeframe. In the Permian Basin, we will continue to engage with the partner organizations with whom we developed relationships during this project and explore opportunities to use our technology in treatment applications within the oil and gas industry. When the regulatory situation allows for beneficial reuse in the Permian Basin, we are confident our technology will provide a compelling technological and economic solution for the first adopters.

## 4. Conclusions

This techno-economic analysis demonstrates significant anticipated economic and technical benefits of ZwitterCo SF pretreatment in produced water desalination processes in the Permian basin.

- At an estimated cost of \$0.11/bbl, the ZwitterCo SF step falls well within the target cost range (< \$0.20/bbl) outlined by the NMPWRC for Permian produced water pretreatment technologies.
- At \$1.34/bbl for a combined process train utilizing membrane distillation for desalination, there is enough room for the additional transport and concentrate disposal costs to come in under the consensus \$2.00/bbl feasibility threshold.
- Preliminary discussions with water midstream collaborators have identified likely transport costs via permanent pipeline to range from \$0.05-0.15/bbl and SWD disposal of process concentrate ranging from \$0.15-0.45/bbl.
- This would make levelized costs for beneficial reuse in the range of \$1.54-\$1.94 per barrel of desalinated water *before* accounting for any offset due to revenues generated from the sale of this treated water.

An extensive study of technology uptake was carried out. Operators, technology vendors, and design engineers gave their opinions. The overwhelming majority of those people interviewed felt that desalination would be required to achieve any meaningful volume of beneficial reuse for produced water. The main conclusion is that without desalination there are essentially no significant opportunities for beneficial reuse in West Texas / Southeast New Mexico. For desalinated produced water there are several beneficial reuse applications including:

- crop irrigation,
- Pecos River augmentation,
- and power plant cooling water.

All of these applications involve relatively large volumes of water. Applications considered unlikely are:

- mining extraction,
- municipal use,
- road spreading, and rangeland watering.

The main conclusion of this market survey study is that demand for low salinity water is high while demand for high salinity water is essentially confined to shale completions operations, which is not considered to be beneficial reuse, and which is already applied with existing technologies. Until future regulations allow treated produced water to be more widely reused, there is little financial incentive for companies to invest in non-oilfield water reuse treatment schemes in the Permian Basin. These conclusions are incorporated in the Techno-Economic Analysis that is developed in the main body of the project report.

## 5. References

Office of Environmental Management, “Standard Review Plan (SRP): Technology Readiness Assessment Report,” US Department of Energy. March 2010

C. Fritzmann, J. Lowenberg, T. Wintgens, T. Melin, “State-of-the-art of reverse osmosis desalination,” *Desal.*, v. 216, p. 1 (2007).

M. Cheryan, N. Rajagopalan, “Membrane processing of oily streams. Wastewater treatment and waste reduction,” *J. Mem. Sci.*, v. 151, p. 13 (1998).

R. Schwantes, K. Chavan, D. Winter, C. Felsmann, J. Pfafferott, “Techno-economic comparison of membrane distillation and MVC in a zero liquid discharge application,” *Desal.*, v. 428, p. 50 (2018).

P. Prakash, “Thermal desalination of produced water in heavy oil assets,” paper presented at the Produced Water Society, Houston Feb (2020). Originally published as: D. Singh, P. Prakash, K.K. Sirkar, “Deoiled produced water treatment using direct-contact membrane distillation,” *I&EC Res.*, v. 52, p. 13439 (2013).



- C. Dotremont, B. Kregersman, R. Sih, K.C. Lai, K. Koh, and H. Seah. "Seawater desalination with memstill technology-a sustainable solution for the industry." *Water Practice and Technology* 5, no. 2 (2010).
- J.M. Lee, T. Frankiewicz, "Treatment of produced water with an ultrafiltration (UF) membrane - a field trial," SPE - 95735, paper presented at the SPE ATCE, Dallas (2005).
- Hydranautics Corp., "HYDRAcap MAX Technology. Solutions you need. Technologies you trust," Hydranautics presentation (2016).
- F.-R. Ahmadun, A. Pendashteh, L.C. Abdullah, D.R.A. Biak, S.S. Madaeni, Z.A. Abidin, "Review of technologies for oil and gas produced water treatment," *J. Haz. Materials*, (2009).
- I.C. Watson, O.J. Morin, L. Henthorne, Desalting Handbook for Planners, Third Edition, report prepared by RosTek Associates, for The Bureau of Reclamation, Denver (2003).
- A. Subramani, J.G. Jacangelo, "Emerging desalination technologies for water treatment: a critical review," *Water Res.*, v. 75 (2015).
- Des Richardson, Norske Skog, "Cost estimation model," UNESCO Center for Mem Sci Tech, Sydney (2009).
- T.V. Bartholomew, "Process and Network Level Optimization for High Salinity Brine Dewatering and Management," PhD Thesis, Carnegie Mellon University, Pittsburgh (2019).
- Redmon, J.H., Kondash, A.J., Womack, D., Lillys, T., Feinstein, L., Cabrales, L., Weinthal, E. and Vengosh, A., "Is Food Irrigated with Oilfield-Produced Water in the California Central Valley Safe to Eat? A Probabilistic Human Health Risk Assessment Evaluating Trace Metals Exposure." *Risk Analysis*. (2020).
- R. Ayers, D.W. Westcot, "Water quality for agriculture," Food and Agriculture Organization (FAO) of the United Nations, Rome <http://www.fao.org/3/t0234e/T0234E00.htm#pre> (1985).
- Groundwater Protection Council, "Produced Water Report," Groundwater Research & Education Foundation. June 2019.

## **Appendix A – Techno-Economic Analysis Spreadsheet**

[Attached Excel File]

## **Appendix B – Beneficial Reuse Uptake – External Factors**

[Attached Report]

This preliminary techno-economic analysis (TEA) is intended to evaluate the economic viability and technical advantages of using ZwitterCo-integrated produced water treatment in the Permian basin. The focus is on using ZwitterCo's novel membrane filtration as pretreatment to desalination in order to generate treated water at a quality high enough for beneficial reuse applications. Beneficial reuse is the use of treated produced water outside of oil and gas operations for the benefit of the local environment and communities. Potential reuse opportunities were also evaluated and ranked on the basis of water demand, proximity to oilfield activity, risk profile, and need.

Several candidate desalination technologies were considered for the analysis as the final treatment step before water reuse. Prior to development of the economic model, the project team focused on the performance, applicability, and various technical details of each candidate technology to select those most feasible for the treatment of produced water.

Four desalination technologies were ultimately selected for the TEA on the basis of technical capability (or in the case of conventional reverse osmosis, for comparison to the industry standard for desalination):

- Conventional Reverse Osmosis (RO)
- Mechanical Vapor Compression (MVC)
- Membrane Distillation (MD), and
- Osmotically Assisted Reverse Osmosis (OARO)

All of these desalination technologies require deep and effective pre-treatment upstream in order to prevent fouling and maintain sustainable treatment. In order to evaluate the economic performance of several different integrated treatment trains, several competitive candidate pre-treatment technologies were considered, including ZwitterCo's zwitterionic ultrafiltration membrane—the development of which is the focus of this grant project. Three ultrafiltration technologies were found to provide the required level of pre-treatment:

- Conventional polymeric polyethersulfone ultrafiltration (PES UF) membranes,
- Ceramic ultrafiltration membranes (Ceramic UF), and
- ZwitterCo polymeric ultrafiltration membranes (ZwitterCo UF).

Each of these technologies is considered to be a “barrier” technology. Barrier technologies perform at a very high level of separation and recovery efficiency and are capable of delivering high quality water to any of the desalination technologies so that they can operate with minimal fouling tendency. Fouling is detrimental to performance and expensive as a result of increased downtime, shorter component life, greater chemical usage, and higher electricity cost. In addition to the ultrafiltration membranes listed above, dissolved gas flotation (DGF) and walnut shell filtration (WSF) were also evaluated. These are considered only as a baseline of comparison among pretreatment options, given that their lower quality effluent (as compared to UF pretreatment) is not suitable for pretreatment to desalination. Later, in evaluating full treatment trains, DGF and WSF are considered as primary treatment ahead of the ultrafiltration step due to their low cost and beneficial effects on ultrafiltration performance and longevity.

The TEA modeling and analysis provides a systematic and head-to-head comparison of CAPEX and OPEX for the different desalination and ultrafiltration pre-treatment technologies. The overall methodology was to break down the OPEX and CAPEX into more detailed components that could each be verified against external sources and estimated with some degree of accuracy. OPEX was broken into:

- Membrane or internal element replacement
- Labor
- Electricity
- Miscellaneous spares and maintenance
- Chemicals

Input for these items was obtained from vendors, personal experience, scientific literature, and from operators in the industry.

In order to evaluate CAPEX of the various process technologies, bids were requested from vendors when possible with the following breakdowns and specifications:

- Skidded system including instrumentation, controls, valves, pumps,
- Clean-in-place (CIP) chemical system for UF membrane systems,
- API oil and gas specifications for pumps, piping, safety, and venting/relief systems
- Materials suitable for oxygen-containing, high salinity water

CAPEX did not include site preparation, utilities infrastructure, nor transportation of equipment to site. CAPEX information was obtained from vendors, literature, and operators. In most cases, the vendors were able to provide highly detailed cost information in the form of a typical bid package.

In a process lineup, pretreatment with UF is followed directly by treatment for desalination. In all process lineups considered, Dissolved Gas Flotation (DGF) and Walnut Shell Filtration (WSF) are used as the first steps, and the furthest upstream. A comparison is then made between the three membrane systems listed above (conventional, ceramic, and ZwitterCo). The focus of this unit process analysis is on the cost comparison between the ZwitterCo membrane and the other pretreatment technologies considered. However, in order for the ZwitterCo membrane to be a viable pretreatment technology, the entire process train must be considered including its effects on the downstream desalination process. The cost benefit of a high performing pretreatment technology, like ZwitterCo UF, comes about through longer equipment life, fewer cleanings, less chemical demand per cleaning, high fluxes, and higher overall recovery.

There are three important factors that are commonly used to calculate CAPEX and OPEX in terms of (a) present value of money, (b) lump sum cost of capital, and (c) unit cost (amortized CAPEX plus OPEX per unit volume of water). These factors are:

1. CCF (Cost Capacity Factor) – this allows scale-up and scale-down of cost information.
2. CEPCI (Chemical Engineering Plant Cost Index) – this allows for the variable cost of equipment over time,
3. CRF (Capital Recovery Factor) – this allows for the calculation of per-barrel costs of capital.

The TEA spreadsheet (*Appendix 1*) provides a worksheet for calculation of each of these factors. The CAPEX and OPEX for each desalination technology are calculated on separate tabs. All UF technologies are calculated on the same tab so that they can be easily compared. A summary of the calculated CAPEX and OPEX for each technology is given in the tab labeled “Unit\_TEA.” Calculations for various systems (process configurations) are calculated in the tab labeled “System\_TEA.” All capital costs were amortized over 10 years and calculated on the basis of a 20,000 bbl/day treatment capacity. |

Results from the pilot study:

- TEA Spreadsheet updates with piloted parameters
  - o Flux: 20 LMH
  - o Operating pressure: keep the same dP assumptions
  - o Recovery: 99%
  - o Cleaning uptime: Assume 1 hr cleaning/day ~95% uptime.
  - o Chemicals- updated cleaning schedule and cleaning concentrations
    - i. pH 2 HCl: Add 54.75 g (approx. 47 mL) of 38% HCl solution to 15-gal water
    - ii. pH 12 Caustic: 170g of NaOH flake and 188 L bleach to 15 gal solution
    - iii. Not sure how much volume of water we assumed for CIP systems

This sheet is intended to help check the calculations, tables and graphs in the written TEA document.

Page

2	Cost of treatment - no desal industry target SF	0.20 \$/bbl 0.111 \$/bbl	
2	Total cost of SF+MD, excluding transp	1.34 \$/bbl desalinated water	
2	Levelized cost of beneficial reuse	1.54 min 1.94 max	
	Viability threshold	2 \$/bbl	
14	Change in estimated capital and opera	0.14 \$/bbl feed 0.111 \$/bbl	From Preliminary TEA
20	TEA Disc NMPWRC target pretreat target desal target	0.10 \$/bbl minimum 0.20 \$/bbl maximum 1.00 \$/bbl minimum 2.00 \$/bbl maximum	
18	Table 11 Orig Base CAPEX CAPEX pilot flux & recovery	0.062 \$/bbl 0.048 \$/bbl	

21 Table 12 OPEX and CAPEX of desalination pretreatment alternatives

\$/bbl	OPEX	CAPEX	Total
DGF & WSF	0.03	0.02	0.05
ZwitterCo UF (SF)	0.06	0.05	0.11
PES UF	0.23	0.06	0.29
Ceramic UF	0.09	0.40	0.50

- |    |   |  |
|----|---|--|
| 22 | <ul style="list-style-type: none"> <li>• DGF and WSF pretreat</li> <li>• ZwitterCo SF</li> <li>• standard polymeric PE</li> <li>• and Ceramic UF</li> </ul> | 0.05 \$/bbl<br>0.11 \$/bbl<br>0.29 \$/bbl<br>0.50 \$/bbl |
|----|---|--|

23	ZwitterCo Capex	0.05
	PES Capex	0.06

21 Table 13 Details of OPEX Cost Model

Membrane replacement	-	0.016	0.167	0.031
Labor	0.013	0.027	0.027	0.039
Electricity	0.001	0.006	0.003	0.003
Misc., maintenance	0.001	0.008	0.008	0.008
Chemicals	0.014	0.006	0.022	0.012
<b>Total OPEX (\$/bbl)</b>	<b>0.03</b>	<b>0.063</b>	<b>0.227</b>	<b>0.094</b>

24 Table 14

Pre-Treatment	ZwitterCo SF	PES UF	ZwitterCo SF	PES UF	ZwitterCo SF	PES UF
Total Cost (\$/bbl)	1.34	1.83	1.60	2.12	4.41	5.21

Desalinated Water Basis	Basis: 20,000 permeate BWPD							
	Brief description	4	5	6	7	8	9	10
		ZwitterCo UF RD	PES UF MVC	ZwitterCo UF MVC	PES UF MD	ZwitterCo UF MD	PES UF QARD	ZwitterCo UF QARD
	Recovery (percent)	55%	50%	55%	50%	55%	50%	55%
<b>Grand Total OPEX, CAPEX, Uptime, Recovery (\$/bbl desal water)</b>		<b>3.61</b>	<b>2.12</b>	<b>1.60</b>	<b>1.83</b>	<b>1.34</b>	<b>5.21</b>	<b>4.41</b>

29	Cost of treatment - no desal- SF only	0.111 \$/bbl
	Combined SF+MD cost	1.34
	Levelized cost of beneficial reuse	1.54 min 1.94 max

Master Spreadsheet for the Techno-Economic Analysis (TEA)  
TEA for Different Scenarios for Desalination using ZwitterCoeration High Performance UF Membranes  
Scenarios are defined below  
Base case is 20,000 BWPD feed

OPEX, CAPEX and Amortization is calculated on other worksheets

Feed water flow rate - Kref	20,000 BWPD
Feed water flow rate - Kref	3,180 m <sup>3</sup> /day

Basis & Scenarios	Basis: 20,000 feed BWPD											
	Scenario Number	Baseline	1	2	3	4	5	6	7	8	9	10
Brief description	PES UF No desal	Ceramic UF No desal	ZwitterCo UF No desal	PES UF RO	ZwitterCo UF RO	PES UF MVC	ZwitterCo UF MVC	PES UF MD	ZwitterCo UF MD	PES UF OARO	ZwitterCo UF OARO	
OPEX	OPEX w/o Amortization (\$/bbl)	Baseline	1	2	3	4	5	6	7	8	9	10
	DGF + WSF	-	-	-	0.03	0.03	0.03	0.03	0.03	0.03	0.03	0.03
	UF	0.23	0.09	0.06	0.23	0.06	0.23	0.06	0.23	0.06	0.23	0.06
	pH adjust for B removal (RO & OARO only)	-	-	-	1.64	1.64	-	-	-	-	1.64	1.64
	Desal	-	-	-	0.12	0.12	0.59	0.59	0.36	0.36	0.38	0.38
Subtotal - OPEX w/o Amortization	0.23	0.09	0.06	2.01	1.85	0.84	0.68	0.62	0.45	2.28	2.12	
CAPEX Amortization	Amortization	Baseline	1	2	3	4	5	6	7	8	9	10
	DGF + WSF	-	-	-	0.01	0.01	0.01	0.01	0.01	0.01	0.01	0.01
	UF	0.06	0.06	0.05	0.06	0.05	0.06	0.05	0.06	0.05	0.06	0.05
	Desal	-	-	-	0.07	0.07	0.13	0.13	0.22	0.22	0.23	0.23
	Subtotal - Amortization	0.06	0.40	0.05	0.14	0.13	0.21	0.19	0.29	0.28	0.31	0.29
Total ex-Uptime	Grand Total OPEX & CAPEX (\$/bbl)	0.29	0.50	0.11	2.16	1.98	1.05	0.87	0.91	0.73	2.59	2.41
Up-Time	Percent Up-Time	88	88	94	88	94	88	94	88	94	88	94
Total w/Uptime	Grand Total OPEX, CAPEX, Uptime (\$/bbl feed)	0.33	0.56	0.12	2.45	2.10	1.20	0.93	1.04	0.78	2.95	2.57
Desalinated Water Basis	Basis: 20,000 permeate BWPD											
	Brief description	PES UF No desal	Ceramic UF No desal	ZwitterCo UF No desal	PES UF RO	ZwitterCo UF RO	PES UF MVC	ZwitterCo UF MVC	PES UF MD	ZwitterCo UF MD	PES UF OARO	ZwitterCo UF OARO
Recovery (percent)	83%	90%	99%	50%	55%	50%	55%	50%	55%	50%	55%	
Grand Total OPEX, CAPEX, Uptime, Recovery (\$/bbl desal water)	0.35	0.55	0.11	4.34	3.61	2.12	1.60	1.83	1.34	5.21	4.41	

System CAPEX & OPEX - 20 kBWPD Feed	OPEX	CAPEX	Total
PES UF	0.227	0.062	0.289
Ceramic UF	0.094	0.402	0.496
ZwitterCo UF	0.063	0.047	0.110
ZwitterCo UF + RO	1.850	0.129	1.979
ZwitterCo UF + MVC	0.681	0.194	0.875
ZwitterCo UF + MD	0.453	0.279	0.732
ZwitterCo UF + OARO	2.118	0.295	2.413

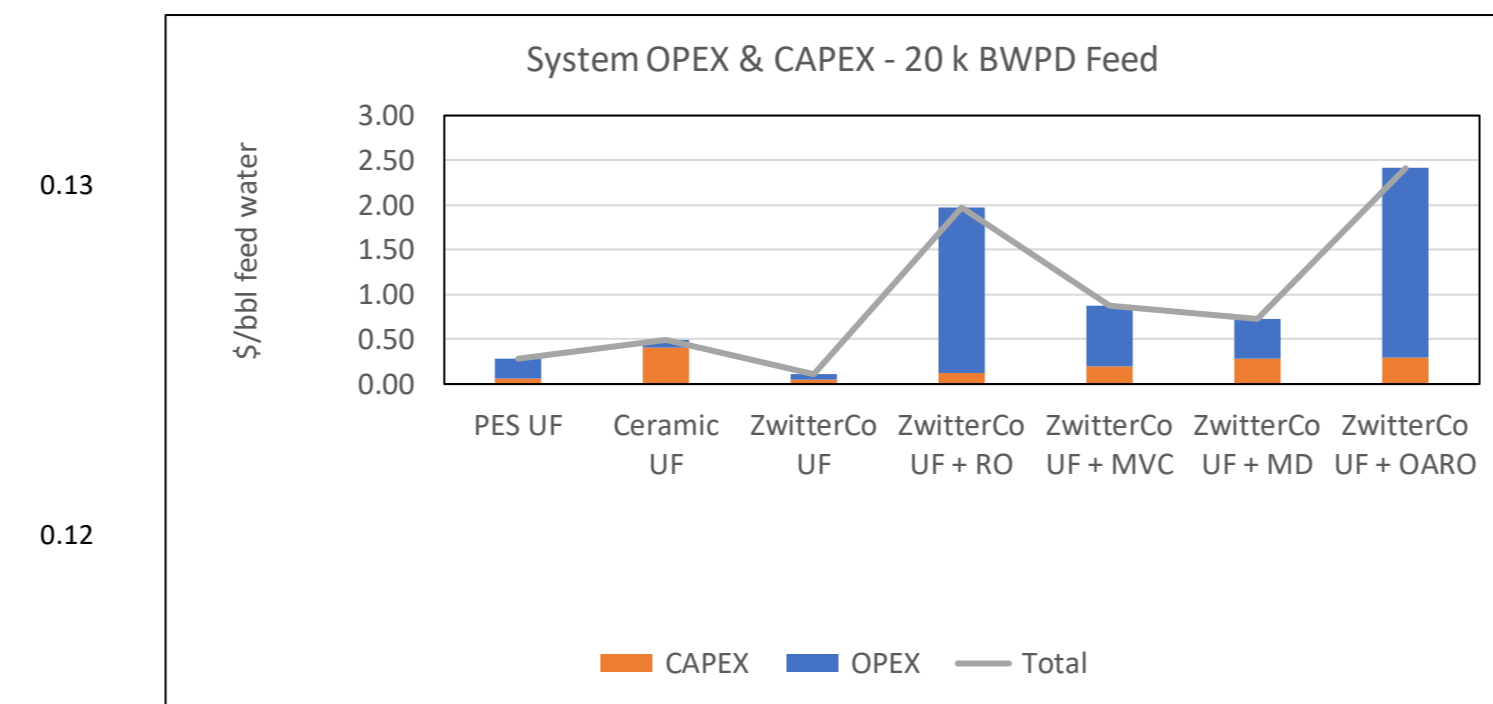

System CAPEX & OPEX - 20 kBWPD Permeate	OPEX
PES UF	0.348
Ceramic UF	0.551
ZwitterCo UF	0.111
ZwitterCo UF + RO	3.615
ZwitterCo UF + MVC	1.598
ZwitterCo UF + MD	1.338
ZwitterCo UF + OARO	4.408

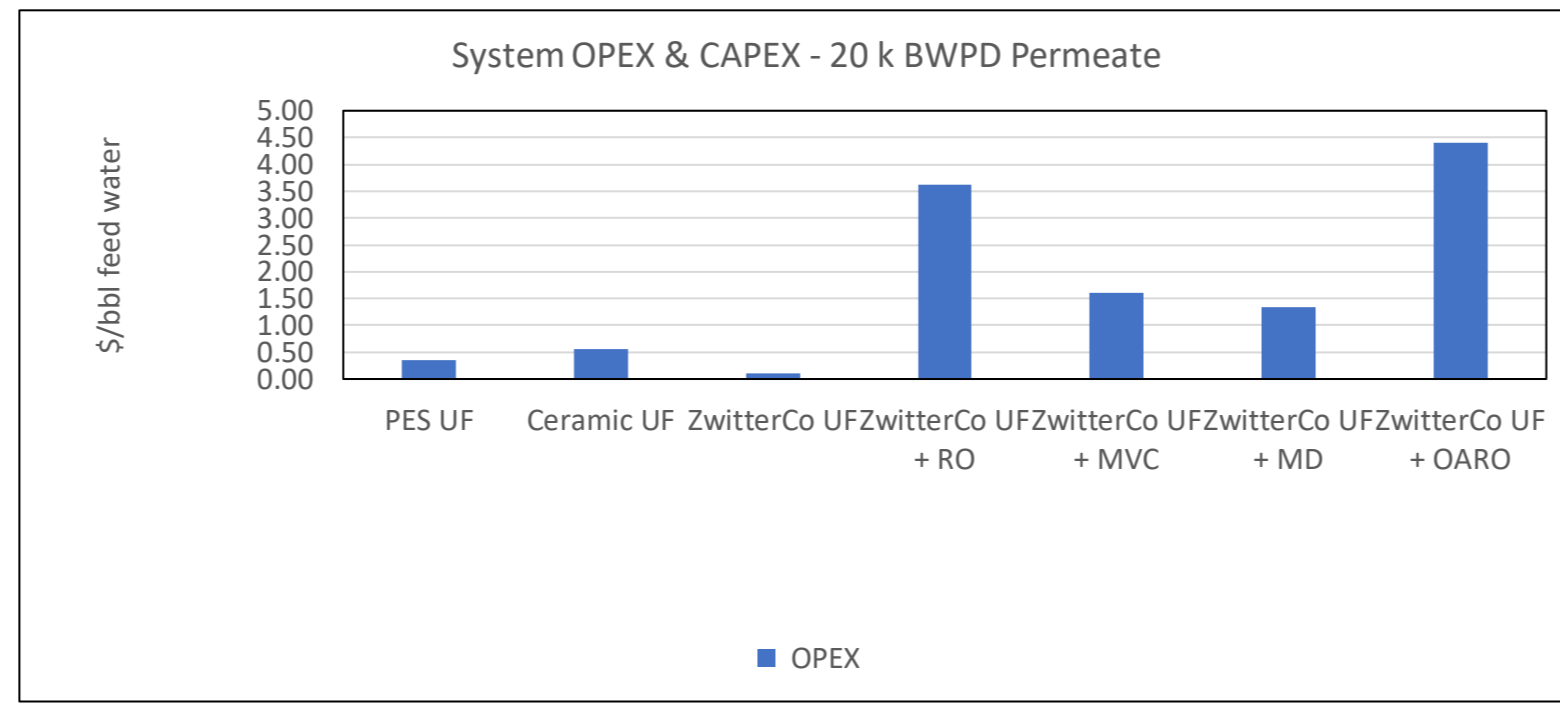

System CAPEX & OPEX - 20 kBWPD Feed	OPEX	CAPEX	Boron pH Adjust	Total
ZwitterCo UF + MD	0.83	0.51	-	1.34
ZwitterCo UF + MVC	1.24	0.35	-	1.60
ZwitterCo UF + OARO	0.87	0.54	3.00	4.41

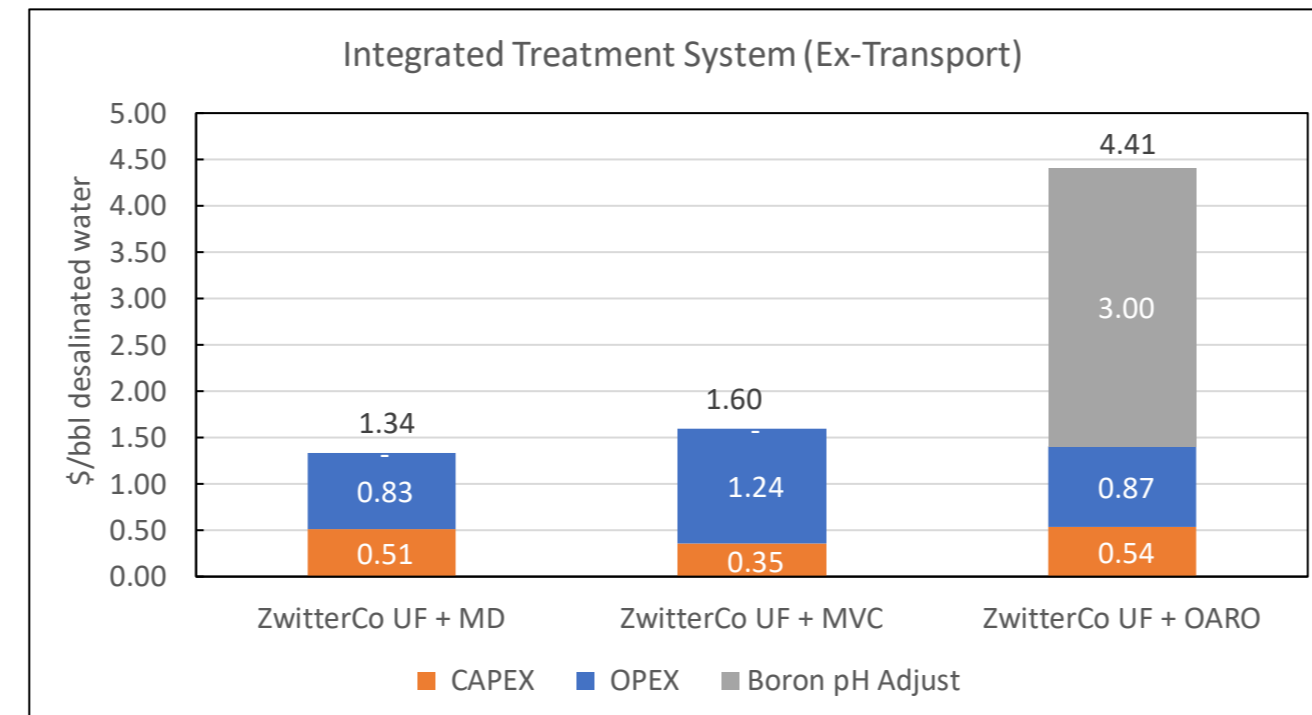

Total cost (OPEX+CAPEX) with and without B treatment  
Flow rate = 20,000 BWPD feed

Desalinated Water Basis	Basis: 20,000 permeate BWPD							
	4	5	6	7	8	9	10	
Brief description	ZwitterCo UF RO	PES UF MVC	ZwitterCo UF MVC	PES UF MD	ZwitterCo UF MD	PES UF OARO	ZwitterCo UF OARO	
Recovery (percent)	55%	50%	55%	50%	55%	50%	55%	
Grand Total OPEX, CAPEX, Uptime, Recovery (\$/bbl desal water)	3.61	2.12	1.60	1.83	1.34	5.21	4.41	

Conversion factors	
3.785	L / gal
42	gal / Bbl
7.48	gal / cu ft
159	L / bbl
1.195	gr mol / scf
42.21	gr mol / scm
454	gr / lb
2.20	lb / kg
1.00E+06	scf / MMscf
2633	lb mol / MMscf
14.5	psi / bar
14.696	psi / atm
1.01333	bar/atm
100	kPa/bar
3.14159	pi
3,600	seconds / hour
1440	minutes / day
24	hours / day
60	minutes / hour
60	seconds / minute
365.25	days/year
3.2808	ft / m
12	inch / foot
144	in <sup>2</sup> / ft <sup>2</sup>
1000	mm / m
100	cm / m
1.609	m/mile
25.4	mm / inch
1,000,000	micron/m
10,000	micron/cm
39.37	mils/mm
10.8	sq ft / sq m
35.31	cu ft / cu m
1,000,000	cu cm / cu m
264	gal / cu m
6.29	Bbl / cu m
1,000	L/cu m
1,000	L/cu m
28.32	L/cu ft
5.62	cu ft / Bbl
9.81	g constant
1.34	HP / kilowatts
0.4327	ft water / psi
3.415	BTU/hr / Watt
100,000	Pa/bar
1000	gr/kg
1000	kg/metric ton
1,000,000	cc/m <sup>3</sup>
1000	L/m <sup>3</sup>
1	Pa/(N/m <sup>2</sup> )
1	N/(kgm/sec <sup>2</sup> )
1000	cc/L (or mL/L)
1,000	mg/gr
4.18	Watt sec /calorie
100,000	dyne/N
1000	cP/Pa sec
1000	dyne/cm/(mN/m)
746	Watt/HP

Unit Cost Data, Comparisons, OPEX for standalone UF:  
Costs for individual units only. No systems.

Basic:	20,000	8WPD
Annual production:	7,300,000	8WPD

OPEX (all costs in \$/bbl)	IGF + WSF	PES UF	Ceramic UF	ZwitterCo UF	RO	MVC	MD	QARO
Membrane / internals replacement	-	0.167	0.031	0.016	0.011	0.110	0.048	0.052
Labor	0.013	0.007	0.009	0.007	0.003	0.006	0.009	0.006
Electricity	0.003	0.003	0.003	0.006	0.005	0.118	2.250	0.245
Misc. spares_maintenance	0.001	0.008	0.008	0.008	0.011	0.010	0.008	0.008
Chemicals	0.014	0.022	0.012	0.006	0.006	0.084	0.014	0.014
<b>Total OPEX</b>	<b>0.030</b>	<b>0.227</b>	<b>0.094</b>	<b>0.063</b>	<b>0.116</b>	<b>0.587</b>	<b>0.360</b>	<b>0.384</b>
<b>CAPEX</b>	<b>815,000</b>	<b>2,988,000</b>	<b>22,660,000</b>	<b>1,750,000</b>	<b>3,800,000</b>	<b>16,540,461</b>	<b>12,300,000</b>	<b>13,161,000</b>
Amortisation cost / year	105,546	413,266	2,834,574	339,950	492,117	969,566	1,592,906	1,704,410
Amortisation cost / barrel	<b>0.015</b>	<b>0.061</b>	<b>0.402</b>	<b>0.047</b>	<b>0.067</b>	<b>0.133</b>	<b>0.218</b>	<b>0.233</b>
<b>Total (CAPEX + OPEX)</b>	<b>0.045</b>	<b>0.289</b>	<b>0.496</b>	<b>0.110</b>	<b>0.183</b>	<b>0.720</b>	<b>0.578</b>	<b>0.618</b>

The strategy used for estimating costs for desalination systems is as follows. It is assumed that PES, ceramic and ZwitterCo membranes are barrier membranes. As such they remove all contaminants that would cause fouling and flux decline in the desalination technologies (RO, MVC, MD, QARO). Thus, the OPEX and CAPEX for each desalination technology is roughly that for seawater service (relatively clean feed). The cost required to bring produced water up to a high degree of cleanliness is borne by the membrane technologies in their OPEX.

\$/bbl	OPEX	CAPEX	Total
IGF + WSF	0.030	0.016	0.046
PES UF	0.227	0.067	0.294
Ceramic UF	0.094	0.402	0.496
RO	0.116	0.067	0.183
MVC	0.587	0.133	0.720
MD	0.360	0.218	0.578
QARO	0.384	0.233	0.618
<b>Percentages</b>	<b>OPEX</b>	<b>CAPEX</b>	<b>Total</b>
IGF + WSF	67	31	100
PES UF	79	21	100
Ceramic UF	19	81	100
ZwitterCo UF	58	42	100
RO	63	37	100
MVC	82	18	100
MD	62	38	100
QARO	62	38	100

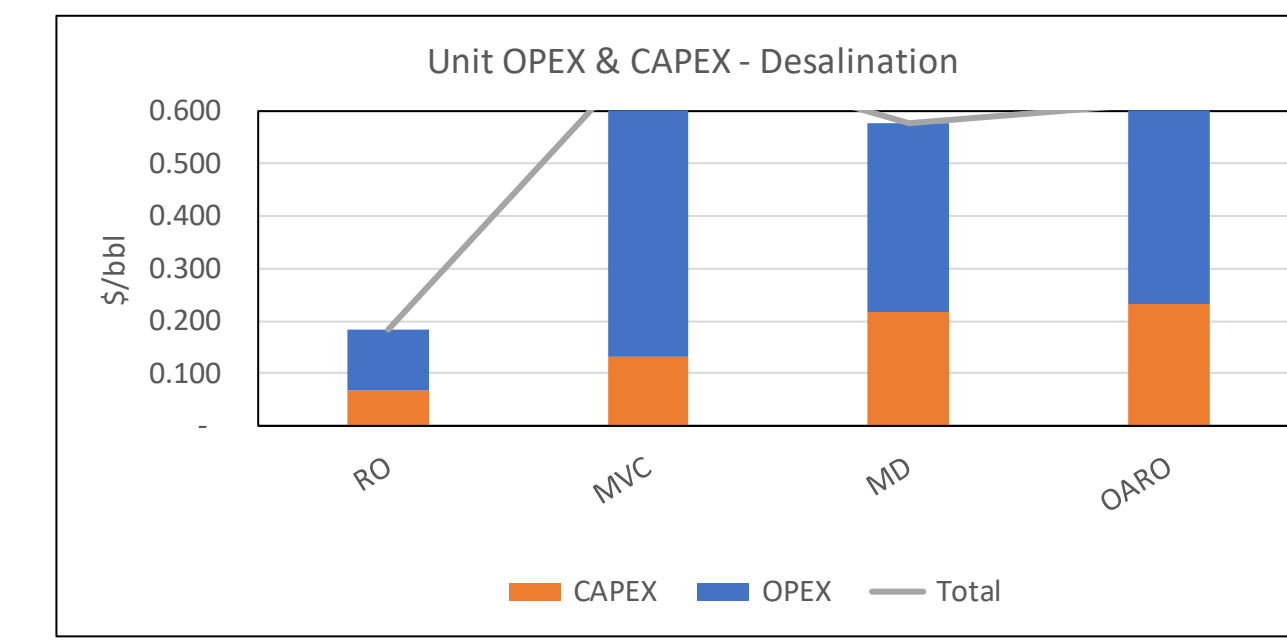
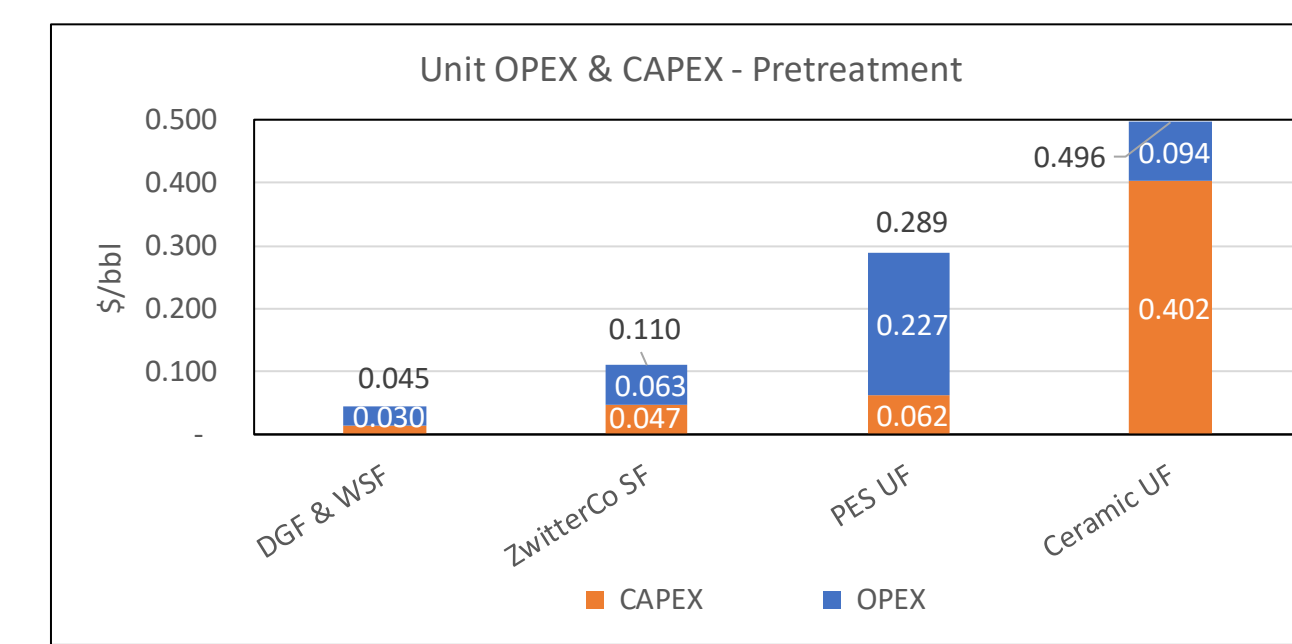
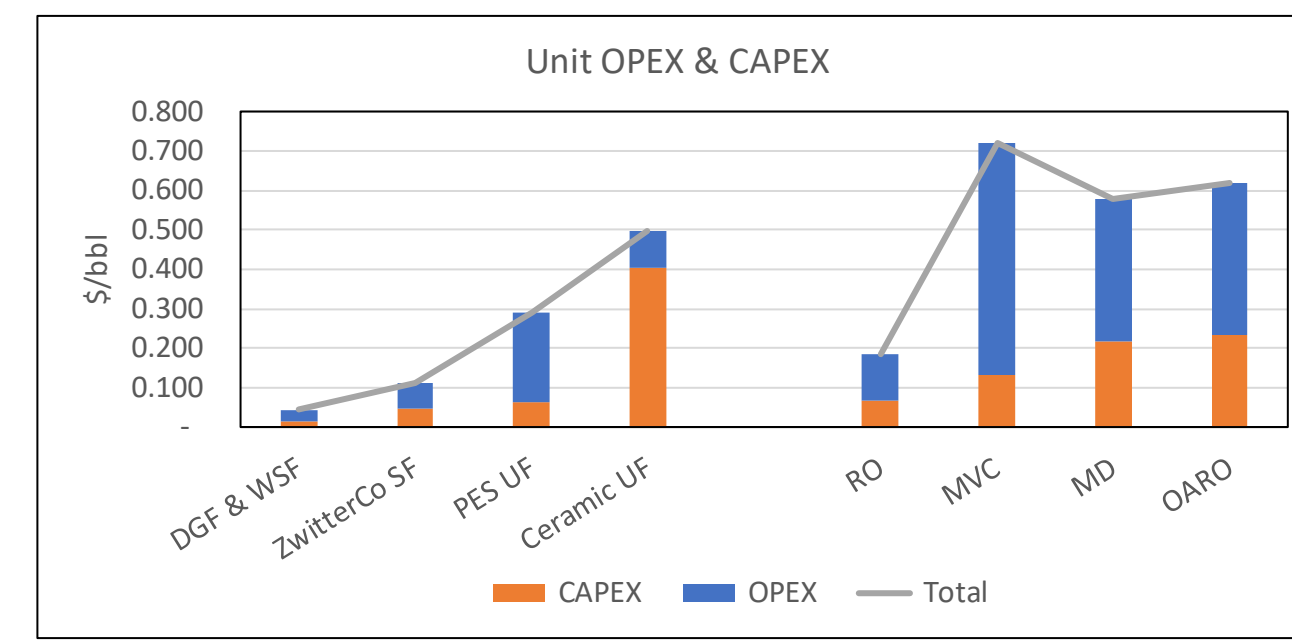

**Worksheet for CRF: Capital Recovery Factor (CAPEX per Bbl)**

The CRF formula is from Schwantes et al. [22], and from the RosTek report [73].

Instructions: use the formula to calculate a CRF

Multiply the CFR times the CAPEX to calculate the capital payment per year

Divide this number by the water production per year to calculate the unit CAPEX

CRF Calculation	formula	
Interest rate (i)	0.050	fraction
Amortization period (y)	10.0	years
CRF (Amortization factor)	0.130	
Years to payoff	7.72	years

Capacity (feed)	10,000	20,000	40,000	BWPD
Capacity (feed)	1,590	3,180	6,359	m3/day
Uptime average per year	98	98	98	%
Days downtime per year	7	7	7	
Capacity per year	3,577,000	7,154,000	14,308,000	BWPY
Capacity per year	568,680	1,137,361	2,274,722	m3/year

CAPEX	0	262,500	0	\$
Amortization cost per year (CRF x CAPEX)	0	33,995	0	\$/year
Cost over amortization period	0	339,950	0	\$ total
Cost per Bbl	0.000	0.005	0.000	\$/bbl
Cost per m3	0.00	0.030	0.00	\$/m3
CAPEX unit cost (\$per bbl/day)		13		\$/((bbl/day)
CAPEX unit cost (\$per m3/day)	0	83	0	\$/((m3/day)

**9.3.4.7 Annual Cost of Capital**

The annual cost of depreciating capital normally includes the owner's cost for interest amortization. The annual payment necessary to repay principal and interest in a present sum of money is called the Capital Recovery Factor. Table 9-5 lists the Capital Recovery Factors for different interest rates and amortization periods. Capital Recovery Factor, multiplied by total capital cost, is the payment each year for a loan at the indicated interest rate (i) and amortization period (y).

$$CRF = \frac{i(1+i)^n}{(1+i)^n - 1}$$

Table 9-5.—Capital recovery factors

Interest rate	Repayment period (years)		
	20	30	40
4.0	0.07358	0.05783	0.05052
4.5	0.07688	0.06139	0.05434
5.0	0.08024	0.06505	0.05828
5.5	0.08368	0.06881	0.06232
6.0	0.08718	0.07265	0.06646
6.5	0.09076	0.07658	0.07069
7.0	0.09439	0.08059	0.07501

Worksheet for CEPCI: Chemical Engineering Plant Cost Index

This formula is from Schwantes et al. [22]

$$C = C_{ref} \left( \frac{\text{Cost index at present year}}{\text{Cost index when estimated}} \right)$$

Year	CEPCI
2000	400
2001	410
2002	420
2003	430
2004	440
2005	470
2006	500
2007	510
2008	590
2009	510
2010	560
2011	580
2012	580
2013	580
2014	580
2015	590
2016	590
2017	600
2018	610
2019	620
2020	630

Year	Cost Index	Cost
2000	400	0.01
2020	630	0.0095

Calculated Results:

Cheryan & Rajagopalan [21]

year	CAPEX	year	CAPEX
1998	1,300	2020	2,048
1998	5,300	2020	8,348

year	OPEX	year	OPEX
1998	0.79	2020	1.24
1998	3.96	2020	6.24

GE Osmonics [xx]

year	OPEX	year	OPEX
2000	0.006	2020	0.0095



Worksheet for CCF: Cost Capacity Factor - used to scale costs against flow rate

This formula is from Schwantes et al. [22]

Reference Capacity (Kref)	20,000	BWPD
Capacity of interest (K)	10,000	BWPD
Cost Capacity Factor (m)	0.50	
CAPEX for reference system (Cref)	3,500,000	\$
CAPEX for system of interest (C)	2,474,874	\$
Unit CAPEX	247	\$/ (BWPD)
Unit CAPEX	1557	\$/ (m3/day)

$$C = C_{ref} \left( \frac{K}{K_{ref}} \right)^m$$

Summary of Water Recovery Rates

References for recovery and uptime information: [12], [23], [25], [35], [86], [94]

Feed Basis

Equipment Cost for permeate flow case		
Permeate flow rate	20,000	bbf/day
Permeate flow rate	3,180	m3/day

Tag Names	Unit Operation	Individual Unit Recovery	Feed/Permeate Ratio	Req'd Feed (bbf/day)
DGF	DGF (Dissolved Gas Flotation)	0.95	1.05	21,053
WSF	WSF (Walnut Shell Filtration)	0.97	1.03	20,619
PESUF	PES Polymeric UF (Ultrafiltration)	0.90	1.11	22,222
NGUF	ZwitterCo Polymeric UF	0.99	1.01	20,202
CERAMIC	Ceramic UF	0.90	1.11	22,222
RO	RO (Reverse Osmosis)	0.60	1.67	33,333
MVC	MVC (Mech Vap Compress)	0.60	1.67	33,333
MD	MD (Membrane Distillation)	0.60	1.67	33,333
OARO	OARO (Osmotically Assisted RO)	0.60	1.67	33,333

Days Downtime per year	Percent Downtime	Percent Uptime
1	0.27%	99.73%
2	0.55%	99.45%
22	6.03%	93.97%
2	0.55%	99.45%
2	0.55%	99.45%
10	2.74%	97.26%
10	2.74%	97.26%
10	2.74%	97.26%
10	2.74%	97.26%

Recovery calculations for process trains

Scenario definitions

Different scenarios are differentiated on the basis of the process flow diagram and the unit operations that are used.  
 Different feed water flow rates do not constitute a different scenario. Use the Cost Capacity Factor (CCF) for different flow rates  
 Different feed water quality might generate a different scenario if the process units need to be adjusted to handle the feed water quality  
 Different treated effluent quality may require a different scenario if the process units need to be adjusted

Scenario	Brief Description	Scenario Description	Lineup
	PES UF / No desal	Baseline	DGF*WSF*PESUF
1	ZwitterCo UF / No desal	Baseline w/ ZwitterCo UF technology (Zwitterco, PolyCera, etc). No desalination	DGF*WSF*NGUF
2	Ceramic UF / No desal	Baseline + conventional RO (at RO maximum salinity ~ 60 gr/L TDS)	DGF*WSF*Ceramic
3	PES UF / RO	Baseline + conventional RO (at RO maximum salinity ~ 60 gr/L TDS)	DGF*WSF*PESUF*RO
4	ZwitterCo UF / RO	Baseline w/ ZwitterCo UF + conventional RO (at RO maximum salinity ~ 60 gr/L TDS)	DGF*WSF*NGUF*RO
5	PES UF / MVC	Baseline + conventional MVC	DGF*WSF*PESUF*MVC
6	ZwitterCo UF /MVC	Baseline w/ ZwitterCo UF + conventional MVC	DGF*WSF*NGUF*MVC
7	PES UF \ MD	Baseline + MD. Effluent TDS < 1,000 mg/L	DGF*WSF*PESUF*MD
8	ZwitterCo UF / MD	Baseline w/ ZwitterCo UF + MD. Effluent TDS < 1,000 mg/L	DGF*WSF*NGUF*MD
9	PES UF /OARO	Baseline + OARO. Effluent TDS < 1,000 mg/L	DGF*WSF*PESUF*OARO
10	ZwitterCo UF /OARO	Baseline w/ZwitterCo UF + OARO	DGF*WSF*NGUF*OARO
11	Near water	Water supplied within 20 miles of facility	
12	Far water	Water supplied between 20 and 40 miles of facility	

Train (process) Recovery	Perm/Feed Capacity Factor	Perm Prod Rate (BWPD)	Required Feed (bbf/day)	Days Downtime per Year	Percent Downtime	Percent Uptime	Required Feed (bbf/day)	Perm/Feed Capacity & Uptime
0.83	1.21	16,587	24,115	25	7%	93%	21,370	25,485
0.99	1.01	19,800	20,202	5	1%	99%	20,274	20,476
0.90	1.11	18,000	22,222	5	1%	99%	20,274	22,496
0.50	2.01	9,952	40,192	35	10%	90%	21,918	42,110
0.55	1.83	10,947	36,538	15	4%	96%	20,822	37,360
0.50	2.01	9,952	40,192	35	10%	90%	21,918	42,110
0.55	1.83	10,947	36,538	15	4%	96%	20,822	37,360
0.50	2.01	9,952	40,192	35	10%	90%	21,918	42,110
0.55	1.83	10,947	36,538	15	4%	96%	20,822	37,360

Unit Cost Data, Comparisons, OPEX:

Conventional Pretreatment System - DGF WSF  
Data from Vendor: WT72020 (confidential source)

Reference System:	840,000	gal/day
	20,000	bbl/day
	3,180	m3/day
	7,200,000	bbl/year

The information in this table comes from vendor WT72020. Some of the information is inconsistent with the other technologies and have been averaged to arrive at a final set of values shown in the red outlined box

Dissolved Gas Flotation Unit		
CAPEX incl installation	315,000	USD
CAPEX unit amortization cost (\$per bbl/day)	16	\$/ (bbl/day)
CAPEX unit amortization cost (\$per m3/day)	99	\$/ (m3 day)

Cost of DGF+WSF. See Tables 7.3 and 7.4.

Category	USD	\$/bbl	\$/m3	% w/o Amort	% w/ Amort	Comments
Amortization cost per year	40,794	0.006	0.036		34%	calculated using CRF at 5%/10 years
Labor	30,000	0.004	0.026	38%	25%	
Electricity	9,400	0.001	0.008	12%	8%	
Misc, waste disposal	2,000	0.000	0.002	3%	2%	
Chemicals	37,500	0.005	0.033	48%	31%	assumes once per week
OPEX unit cost w/o amortization	78,900	0.011	0.069	100%		
OPEX unit cost w/ amortization	119,694	0.017	0.105		100%	

Walnut Shell Filter System		
CAPEX incl installation	500,000	USD
CAPEX unit cost incl installation	25	\$/ (bbl/day)
CAPEX unit cost incl installation	157	\$/ (m3 day)

Cost of DGF+WSF. See Tables 7.3 and 7.4.

Category	Annual Costs					Comments
	USD	\$/bbl	\$/m3	% w/o Amort	% w/ Amort	
Amortization cost per year	64,752	0.009	0.057		33%	calculated using CRF at 5%/10 years
Labor	50,000	0.007	0.044	38%	25%	
Electricity	15,600	0.002	0.014	12%	8%	
Misc, waste disposal	4,000	0.001	0.003	3%	2%	
Chemicals	62,500	0.009	0.055	47%	32%	assumes once per week
OPEX w/o amortization	132,100	0.018	0.115	100%		
OPEX w/ amortization	196,852	0.027	0.172		100%	

Reference System:	840,000	gal/day
	20,000	bbl/day
	3,180	m3/day
	7,200,000	bbl/year

Combined DGF + WSF		
CAPEX incl installation	815,000	USD
CAPEX unit cost incl installation	41	\$/ (bbl/day)
CAPEX unit cost incl installation	256	\$/ (m3 day)

Cost of DGF+WSF. See Tables 7.3 and 7.4 in the report.

Category	Annual Costs					Comments
	USD	\$/bbl	\$/m3	% w/o Amort	% w/ Amort	
Membrane replacement cost/year	0	-	-	0%	0%	
Labor	95,983	0.013	0.084	47%	31%	
Electricity	4,299	0.001	0.004	2%	1%	
Misc, spares, maintenance	6,000	0.001	0.005	3%	2%	
Chemicals	100,000	0.014	0.087	48%	32%	assumes once per week
OPEX w/o amortization	206,282	0.029	0.180	100%		
Amortization cost per year	105,546	0.015	0.092		34%	calculated using CRF at 5%/10 years
OPEX w/ amortization	311,828	0.043	0.272		100%	

CRF Calculation	formula	
Interest rate (i)	0.050	fraction
Amortization period (y)	10.0	years
CRF (Amortization factor)	0.130	
Years to payoff	7.72	years

Capacity (permeate production rate)	10,000	20,000	40,000	BWPD
Capacity (permeate production rate)	1,590	3,180	6,359	m3/day
Uptime average per year	98	98	98	%
Days downtime per year	7	7	7	
Capacity per year	3,577,000	7,154,000	14,308,000	BWPY
Capacity per year	568,680	1,137,361	2,274,722	m3/year

CAPEX	0	315,000	0	\$
Amortization cost per year (CRF x CAPEX)	0	40,794	0	\$/year
Cost over amortization period	0	407,939	0	\$/total
Cost per Bbl	0.000	0.006	0.000	\$/bbl
Cost per m3	0.00	0.036	0.00	\$/m3
CAPEX unit cost (\$per bbl/day)		16		\$/ (bbl/day)
CAPEX unit cost (\$per m3/day)	0	99	0	\$/ (m3/day)

CRF Calculation	formula	
Interest rate (i)	0.050	fraction
Amortization period (y)	10.0	years
CRF (Amortization factor)	0.130	
Years to payoff	7.72	years

Capacity (permeate production rate)	10,000	20,000	40,000	BWPD
Capacity (permeate production rate)	1,590	3,180	6,359	m3/day
Uptime average per year	98	98	98	%
Days downtime per year	7	7	7	
Capacity per year	3,577,000	7,154,000	14,308,000	BWPY
Capacity per year	568,680	1,137,361	2,274,722	m3/year

CAPEX	0	500,000	0	\$
Amortization cost per year (CRF x CAPEX)	0	64,752	0	\$/year
Cost over amortization period	0	647,523	0	\$/total
Cost per Bbl	0.000	0.009	0.000	\$/bbl
Cost per m3	0.00	0.057	0.00	\$/m3
CAPEX unit cost (\$per bbl/day)		25		\$/ (bbl/day)
CAPEX unit cost (\$per m3/day)	0	157	0	\$/ (m3/day)



Unit Cost Data, Comparisons, OPEX for standalone RO:  
Pretreatment is not included

Original information from Fritzmann [12] for SWRO: 6.29

	OPEX Cost (\$/m3)	OPEX Cost (\$/bbl)	% of OPEX Cost	Total Cost (\$/m3)	Total Cost (\$/bbl)	% of Total Cost
Amortization				0.43	0.07	36
Membrane replacement cost	0.07	0.01	9	0.07	0.01	6
Labor	0.05	0.01	6	0.05	0.01	4
Electricity	0.52	0.08	68	0.52	0.08	43
Misc, maintenance	0.09	0.01	12	0.09	0.01	8
Chemicals	0.04	0.01	5	0.04	0.01	3
Totals	0.77	0.12	100	1.20	0.19	100

Electricity cost:	0.08 \$/kWh
Typical energy consumption	6.50 kWh/m3
Energy cost	0.52 \$/m3
Energy cost	0.08 \$/bbl

Capacity (feed)	20000 BWPD
CAPEX	3,800,000 \$
Amortization cost per year	492,117 \$
Amortization cost per m3	0.43 \$/m3
Amortization cost per bbl	0.07 \$/bbl

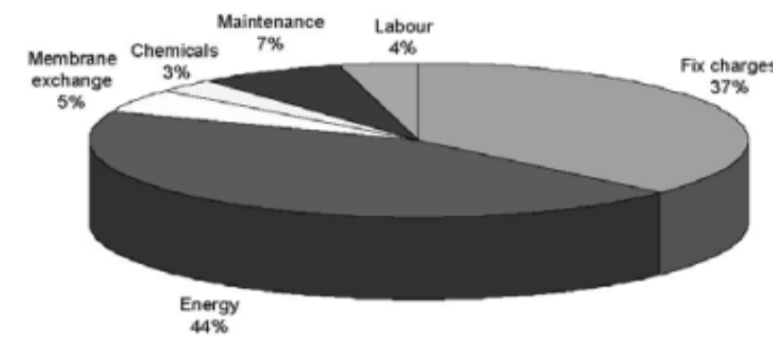

Fig. 50. Water distribution cost in an SWRO plant

Fritzmann [12], p. 67

CRF Calculation	formula
Interest rate (i)	0.050 fraction
Amortization period (y)	10.0 years
CRF (Amortization factor)	0.130
Years to payoff	7.72 years

Capacity (feed)	10,000	20,000	40,000	BWPD
Capacity (feed)	1,590	3,180	6,359	m3/day
Uptime average per year	98	98	98	%
Days downtime per year	7	7	7	
Capacity per year	3,577,000	7,154,000	14,308,000	BWPY
Capacity per year	568,680	1,137,361	2,274,722	m3/year

CAPEX	0	3,800,000	0	\$
Amortization cost per year (CRF x CAPEX)	0	492,117	0	\$/year
Cost over amortization period	0	4,921,174	0	\$ total
Cost per Bbl	0.000	0.069	0.000	\$/bbl
Cost per m3	0.00	0.433	0.00	\$/m3
CAPEX unit cost (\$per bbl/day)		193		\$/ (bbl/day)
CAPEX unit cost (\$per m3/day)	0	1,195	0	\$/ (m3/day)

PES or ZwitterCo membrane upstream RO

System of interest Feed Capacity:	840,000 gal/day
	20,000 bbl/day
	3,180 m3/day
Percent up-time	100%
	7,300,000 bbl/year

CAPEX including installation	3,800,000 USD
CAPEX incl installation	1,195 \$/(m3 day)
CAPEX incl installation	190 \$/(bbl/day)

Category	Annual Costs		\$/m3	% w/o Amort	% w/ Amort
	USD	\$/bbl			
Membrane replacement cost/year	80,000	0.011	0.069	9%	6%
Labor	383,932	0.053	0.331	45%	29%
Electricity	257,942	0.035	0.222	30%	19%
Misc, spares, maintenance	80,000	0.011	0.069	9%	6%
Chemicals	45,000	0.006	0.039	5%	3%
Costs w/o amortization	846,874	0.116	0.730	100%	
Amortization cost per year	492,117	0.067	0.424		37%
Costs w/ amortization	1,338,991	0.183	1.154		100%

CRF Calculation	formula
Interest rate (i)	0.050 fraction
Amortization period (y)	10.0 years
CRF (Amortization factor)	0.130
Years to payoff	7.72 years

Capacity (permeate production rate)	10,000	20,000	40,000	BWPD
Capacity (permeate production rate)	1,590	3,180	6,359	m3/day
Uptime average per year	98	98	98	%
Days downtime per year	7	7	7	
Capacity per year	3,577,000	7,154,000	14,308,000	BWPY
Capacity per year	568,680	1,137,361	2,274,722	m3/year

CAPEX	0	9,330,000	0	\$
Amortization cost per year (CRF x CAPEX)	0	1,208,278	0	\$/year
Cost over amortization period	0	12,082,777	0	\$ total
Cost per Bbl	0.000	0.169	0.000	\$/bbl
Cost per m3	0.00	1.062	0.00	\$/m3
CAPEX unit cost (\$per bbl/day)		474		\$/ (bbl/day)
CAPEX unit cost (\$per m3/day)	0	2,934	0	\$/ (m3/day)

**Unit Cost Data, Comparisons, OPEX for standalone MVC:**  
**Pretreatment is not included**

<b>Basis:</b>	20,000	BWPD
<b>Uptime</b>	100%	
<b>Annual production</b>	7,300,000	BWPY

Note: MVC OPEX is assumed to be the same for PES upstream as for ZwitterCo upstream.  
 Both UF technologies will act as effective barriers.

<b>MVC Costs PES or ZwitterCo upstream</b>	840,000	gal/day
	20,000	bbl/day
	3,180	m3/day
	100%	
	7,300,000	bbl/year

CAPEX including installation	16,540,461	USD
CAPEX incl installation	5,202	\$/m3 day)
CAPEX incl installation	827	\$/bbl/day)

Category	Annual Costs	Costs including amortization			Costs not including amortization		
	USD	\$/bbl	\$/m3	percentage	\$/bbl	\$/m3	percentage
Membranes / interanls replacement	800,000	0.110	0.689	27%	0.110	0.689	41%
Labor	479,915	0.066	0.414	16%	0.066	0.414	24%
Electricity	-	-	-	0%	-	-	0%
Misc, spares, maintenance	75,000	0.010	0.065	3%	0.010	0.065	4%
Chemicals	615,000	0.084	0.530	21%	0.084	0.530	31%
Sub-total cost w/o amortization	1,969,915	0.270	1.697	67%	0.270	1.697	100%
Amortization cost per year	969,566	0.133	0.852	33%			
Costs w/ amortization	2,939,481	0.403	2.533	67%			

<b>CRF Calculation</b>	formula	
Interest rate (i)	0.050	fraction
Amortization period (y)	10.0	years
CRF (Amortization factor)	0.130	
Years to payoff	7.72	years

Capacity (feed)	10,000	20,000	40,000	BWPD
Capacity (feed)	1,590	3,180	6,359	m3/day
Uptime average per year	98	98	98	%
Days downtime per year	7	7	7	
Capacity per year	3,577,000	7,154,000	14,308,000	BWPY
Capacity per year	568,680	1,137,361	2,274,722	m3/year

CAPEX	0	7,486,735	0	\$
Amortization cost per year (CRF x CAPEX)	0	969,566	0	\$/year
Cost over amortization period	0	9,695,664	0	\$ total
Cost per Bbl	0.000	0.136	0.000	\$/bbl
Cost per m3	0.00	0.852	0.00	\$/m3
CAPEX unit cost (\$per bbl/day)		380		\$/bbl/day)
CAPEX unit cost (\$per m3/day)	0	2,355	0	\$/m3/day)

Information from Dave Ciszewski at Suez:

**Case 1 - 120k TDS at 60% recovery**

- 1000 bpd feed: Equipment Capex - \$1600/bpd; Total Installed Capex - \$3700/bpd; Main Opex: 2.7 kWh/bbl; Spares/Maintenance @5% of total Capex
- 10,000 bpd feed: Equipment Capex - \$430/bpd; Total Installed Capex - \$950/bpd; Main Opex: 2.7 kWh/bbl; Spares/Maintenance @4% of total Capex
- 100,000 bpd feed: Equipment Capex - \$300/bpd; Total Installed Capex - \$600/bpd; Main Opex: 2.7 kWh/bbl; Spares/Maintenance @3.5% of total Capex

**Case 2 - 150k TDS at 50% recovery**

- 1000 bpd feed: Equipment Capex - \$1500/bpd; Total Installed Capex - \$3500/bpd; Main Opex: 2.3 kWh/bbl; Spares/Maintenance @5% of total Capex
- 10,000 bpd feed: Equipment Capex - \$400/bpd; Total Installed Capex - \$880/bpd; Main Opex: 2.3 kWh/bbl; Spares/Maintenance @4% of total Capex
- 100,000 bpd feed: Equipment Capex - \$260/bpd; Total Installed Capex - \$520/bpd; Main Opex: 2.3 kWh/bbl; Spares/Maintenance @3.5% of total Capex

Upscaling the numbers from 10,000 to 20,000 BWPD:

Reference Capacity (Kref)	10,000	BWPD
Capacity of interest (K)	20,000	BWPD
Cost Capacity Factor (m)	0.80	
CAPEX for reference system (Cref)	9,500,000	\$
CAPEX for system of interest (C)	16,540,461	\$
Unit CAPEX	827	\$/BWPD)
Unit CAPEX	5202	\$/m3/day)

**Unit Cost Data, Comparisons, OPEX for standalone MD:**

**Pretreatment is not included**

Original information from Fritzmann [12]:

**PES or ZwitterCo UF upstream of MD**

System of interest Feed Capacity:	840,000	gal/day
	20,000	bbl/day
	3,180	m3/day
	100%	
	7,300,000	bbl/year

CAPEX including installation	12,300,000	USD
CAPEX incl installation	3,868	\$/m3 day
CAPEX incl installation	615	\$/bbl/day

Category	Annual Costs				
	USD	\$/bbl	\$/m3	% w/o Amort	% w/ Amort
Membrane replacement cost/year	351,429	0.048	0.303	44%	15%
Labor	287,949	0.039	0.248	36%	12%
Electricity	-	-	-	0%	0%
Misc, spares, maintenance	60,000	0.008	0.052	8%	3%
Chemicals	100,000	0.014	0.086	13%	4%
Costs w/o amortization	799,377	0.110	0.689	100%	
Amortization cost per year	1,592,906	0.218	1.373		67%
Costs w/ amortization	2,392,283	0.328	2.061		100%

CRF Calculation	formula	
Interest rate (i)	0.050	fraction
Amortization period (y)	10.0	years
CRF (Amortization factor)	0.130	
Years to payoff	7.72	years

Capacity (permeate production rate)	10,000	20,000	40,000	BWPD
Capacity (permeate production rate)	1,590	3,180	6,359	m3/day
Uptime average per year	98	98	98	%
Days downtime per year	7	7	7	
Capacity per year	3,577,000	7,154,000	14,308,000	BWPY
Capacity per year	568,680	1,137,361	2,274,722	m3/year

CAPEX	0	12,300,000	0	\$
Amortization cost per year (CRF x CAPEX)	0	1,592,906	0	\$/year
Cost over amortization period	0	15,929,063	0	\$ total
Cost per Bbl	0.000	0.223	0.000	\$/bbl
Cost per m3	0.00	1.401	0.00	\$/m3
CAPEX unit cost (\$per bbl/day)		625		\$/bbl/day
CAPEX unit cost (\$per m3/day)	0	3,868	0	\$/m3/day

**Unit Cost Data, Comparisons, OPEX for standalone OARO:**

**Pretreatment is not included**

Original information from Fritzmann [12]:

**PES or ZwitterCoeration UF upstream of OARO**

System of interest Feed Capacity:	840,000	gal/day
	20,000	bbl/day
	3,180	m3/day
	100%	
	7,300,000	bbl/year

CAPEX including installation	13,161,000	USD
CAPEX incl installation	4,139	\$/m3 day
CAPEX incl installation	658	\$/bbl/day

Category	Annual Costs				
	USD	\$/bbl	\$/m3	% w/o Amort	% w/ Amort
Membrane replacement cost/year	376,029	0.052	0.324	37%	14%
Labor	479,915	0.066	0.414	47%	18%
Electricity	-	-	-	0%	0%
Misc, spares, maintenance	60,000	0.008	0.052	6%	2%
Chemicals	100,000	0.014	0.086	10%	4%
Sub-total cost w/o amortization	1,015,943	0.139	0.875	100%	
Amortization cost per year	1,704,410	0.233	1.469		63%
Costs w/ amortization	2,720,353	0.373	2.344		100%

CRF Calculation	formula	
Interest rate (i)	0.050	fraction
Amortization period (y)	10.0	years
CRF (Amortization factor)	0.130	
Years to payoff	7.72	years

Capacity (feed)	10,000	20,000	40,000	BWPD
Capacity (feed)	1,590	3,180	6,359	m3/day
Uptime average per year	100	100	100	%
Days downtime per year	0	0	0	
Capacity per year	3,650,000	7,300,000	14,600,000	BWPY
Capacity per year	580,286	1,160,572	2,321,145	m3/year

CAPEX	0	13,161,000	0	\$
Amortization cost per year (CRF x CAPEX)	0	1,704,410	0	\$/year
Cost over amortization period	0	17,044,097	0	\$ total
Cost per Bbl	0.000	0.233	0.000	\$/bbl
Cost per m3	0.00	1.469	0.00	\$/m3
CAPEX unit cost (\$per bbl/day)		669		\$/bbl/day
CAPEX unit cost (\$per m3/day)	0	4,139	0	\$/m3/day



**Membrane Replacement**

See Table 7.10 in the text of the report

UF System

Ref.: Cheryan & Rajagopalan [21]:

Category		
CAPEX incl installation	1,500,000	\$
Capacity	20,000	BWPD

	\$	% of total	
Annual amortized capital	220,000	57%	calculated using CRF
Membrane replacement	54,000	14%	
Labor	80,000	21%	
Electricity	25,000	6%	
Cleaning chemicals	6,000	2%	
Total annual costs	385,000	100%	

UF system

Ref.: Lee & Frankiewicz [27]:

6.29

	cents/bbl	cents/m3	percentage
Membrane replacement cost	2.30	14.47	15%
Labor	6.00	37.74	39%
Pumping / electricity cost	2.47	15.54	16%
Scale inhibitor	1.46	9.18	9%
Waste disposal	0.23	1.45	1%
Wash water cost	0.68	4.28	4%
Cleaning chemicals	2.35	14.78	15%
Total Cost	15.49	97.43	100%

25,000	bbl/day
360	days/year
9,000,000	bbl/year
207,000	\$/year
540,000	\$/year
222,300	\$/year
131,400	\$/year
20,700	\$/year
61,200	\$/year
211,500	\$/year
1,394,100	\$/year

Summary of membrane replacement cost:

Conventional UF should last a year or two assuming some degree of upstream treatment.	system capex x 20 % /once per year
ZwitterCo UF should last 5 to 7 years assuming DGF/WSF upstream treatment.	system capex x 20 % / once per 7 years.

**Labor Cost Estimate**

References:

Table 7.16, Cheryan and Rajagopalan [21]

Table 7.17 Lee and Frankiewicz [27]

Table 7 of Ahmadun [61]

Ahmadun [61] cost of FTE		
Hourly rate [61] (in year 2000)	32.00	Euro/hour
Currency conversion	1.09	\$/Euro
CEPCI (2020/2000)	1.58	\$/2020 / \$ 2000
Hourly rate (in 2020 dollars)	54.78	\$/hour
Effective Cost (all-inclusive)	113,952	\$/year
Hours/year	8,760	hours/year
Cost per person (56h workweek) / year	159,972	\$/ (person year)
Cost / year	479,915	\$/year (3 people)

all inclusive, benefits, etc.

Note: FTE is a Full Time Employee. Cost of FTE includes wage, health insurance, 401k benefits, paid leave, etc.

**Table 7**  
Points of departure for calculation of yearly operational costs [129].

	New offshore installation	Existing offshore installation
Depreciation	$0.163 \times I$	$0.264 \times I$
Maintenance	$\text{\$/m}^3 \text{ (i.s./e.f.)} \times Q$	$\text{\$/m}^3 \text{ (i.s./e.f.)} \times Q$
Spare parts	$\text{\$/m}^3 \text{ (i.s./e.f.)} \times Q$	$\text{\$/m}^3 \text{ (i.s./e.f.)} \times Q$
Use of chemicals	$\text{\$/kg} \times \text{kg/m}^3 \text{ (i.s.)} \times Q$	$\text{\$/kg} \times \text{kg/m}^3 \text{ (i.s.)} \times Q$
Use of potable water	$\text{\$/m}^3 \times \text{amount m}^3/\text{year (i.s.)}$	$\text{\$/m}^3 \times \text{amount m}^3/\text{year (i.s.)}$
Other regular uses	i.s.	i.s.
Operation (crew)	$\text{\$/h} \times \text{amount h/year (e.f.)}$	$\text{\$/h} \times \text{amount h/year (e.f.)}$
Energy	$\text{\$/kWh} \times \text{kWh/year (i.s.)}$	$\text{\$/kWh} \times \text{kWh/year (i.s.)}$
Removal of sludge		
Regular quantity	$\text{\$/t} \times \text{t/1000 kg} \times \text{amount kg sludge/m}^3 \text{ (e.f.)} \times Q$	$\text{\$/t} \times \text{t/1000 kg} \times \text{amount kg/m}^3 \text{ (e.f.)} \times Q$
Small quantity (<3500 kg/year)	$\text{\$/t} \times \text{t/1000 kg} \times \text{amount kg/m}^3 \text{ (e.f.)} \times Q$	$\text{\$/t} \times \text{t/1000 kg} \times \text{amount kg/m}^3 \text{ (e.f.)} \times Q$
Mercury containing sludge	$\text{\$/t} \times \text{t/1000 kg} \times \text{amount kg/m}^3 \text{ (e.f.)} \times Q$	$\text{\$/t} \times \text{t/1000 kg} \times \text{amount kg/m}^3 \text{ (e.f.)} \times Q$
Radioactive waste	$\text{\$/t} \times \text{t/1000 kg} \times \text{amount kg/m}^3 \text{ (e.f.)} \times Q$	$\text{\$/t} \times \text{t/1000 kg} \times \text{amount kg/m}^3 \text{ (e.f.)} \times Q$

I, total investment costs in Euro (CAPEX); Q, yearly treatment flow in m<sup>3</sup>/year; i.s., information supplier; e.f., best estimate by authors fact sheet. Usually, yearly OPEX will amount approximately 35–45% of the CAPEX (I).

System feed capacity	20,000.000	BWPD	6.29
----------------------	------------	------	------

Labor for individual unit operations	Number of FTE staff	Labor Cost per year	Labor Cost per bbl	Labor Cost per m3
DGF + WSF	0.200	95,983	0.013	0.08
PES UF (conventional UF)	0.400	191,966	0.026	0.17
Ceramic UF	0.600	287,949	0.039	0.25
ZwitterCo UF	0.400	191,966	0.026	0.17
RO	0.800	383,932	0.053	0.33
MVC	1.000	479,915	0.066	0.41
MD	0.600	287,949	0.039	0.25
OARO	1.000	479,915	0.066	0.41

Labor for systems (combo of units)	Number of FTE staff	Labor Cost per year	Labor Cost per bbl	Labor Cost per m3
0 Baseline: PES UF / No desal	0.60	287,949	0.039	0.25
1 Ceramic UF / No desal	0.80	383,932	0.053	0.33
2 ZwitterCo UF / No desal	0.60	287,949	0.039	0.25
3 PES UF / RO	1.40	671,881	0.092	0.58
4 ZwitterCo UF / RO	1.40	671,881	0.092	0.58
5 PES UF / MVC	1.60	767,864	0.105	0.66
6 ZwitterCo UF /MVC	1.60	767,864	0.105	0.66
7 PES UF / MD	1.20	575,898	0.079	0.50
8 ZwitterCo UF / MD	1.20	575,898	0.079	0.50
9 PES UF /OARO	1.60	767,864	0.105	0.66
10 ZwitterCo UF /OARO	1.60	767,864	0.105	0.66

Labor Capacity Factor (m)	0.40
---------------------------	------

	System Feed Capacity (BWPD)			
	1,000	20,000	100,000	
DGF + WSF	0.03	0.10	0.19	number of people
UF (conventional & ZwitterCo)	0.06	0.20	0.38	number of people
Desalination	0.18	0.60	1.14	number of people
Total	0.27	0.90	1.71	number of people
Cost per year	130,315	431,923	822,233	\$/year
Cost per bbl	0.357	0.059	0.023	\$/bbl
Cost per m3	2.246	0.372	0.142	\$/m3

365	days per year
24	hours/ day
8,760	hours/year

$$C = C_{ref} \left( \frac{K}{K_{ref}} \right)^m$$

**Pump Example Calculation**

energy cost	23.45	USD/MMBTU
energy cost	0.080	USD/kWh
uptime	100	%
uptime	365	days/year
downtime	0	days/year
total days / year	365	days/year

<b>Pump power calculation</b>		
flow rate	20,000	bbl/day
flow rate	3,180	m3/day
flow rate	132	m3/hr
flow rate	583	gpm
density of the water	1,025.0	kg/m3
differential pressure	144.0	psig
differential pressure	9.93	bar
differential head	98.76	m
fluid pumping power	36.5	kW
pump efficiency	0.60	
shaft power	60.9	kW
shaft power	81.7	HP
hours in a day	24	hours/day
energy per day	1,462	kWh/day
energy per barrel water	0.073	kWh/bbl
energy per cubic meter water	0.4598	kWh/m3
energy cost	0.08001	USD/kWh
energy cost	116.97	USD/day
energy cost	116.97	USD/day
energy cost	0.00585	USD/bbl
energy cost	0.0368	USD/m3
energy cost	117	USD/day
energy cost	42,694	USD/year

<b>Solar Taurus 60 - power output</b>		
power output	5,670	kW
energy output	136,080	kWh/day
energy output	49,669,200	kWh/year

<b>Single Calc - for verification</b>	
20,000	Bbl/day
144.00	psig
6.29	Bbl / cu m
14.5	psi / bar
0.60	pump efficiency
1,462	kWh/day

<b>Example pressure to Head conversion</b>		
pressure	90.0	psig
pressure	6.21	bar
head	61.7	m

<b>Example head to Pressure conversion</b>		
head	57.5	m
pressure	5.8	bar
pressure	83.84	psig

compare

<b>Electricity cost for individual technologies</b>		
Feed flow rate	20,000	BWPD
Electricity unit price	0.080	USD/kWh

<b>Pumping Energy</b>	<b>IGF + WSF</b>	<b>PES UF</b>	<b>Ceramic UF</b>	<b>ZwitterCo UF</b>	<b>RO</b>	<b>MVC</b>	<b>MD</b>	<b>OARO</b>	<b>Units</b>
Differential pressure	14.5	72.0	72.0	144.0	870.0				psig
Differential pressure	1.0	5.0	5.0	9.9	60.0				bar
Energy cost	4,299	21,347	21,347	42,694	257,942				\$/year
Energy cost	0.001	0.003	0.003	0.006	0.035				\$/bbl

<b>Thermal/Other Energy</b>	<b>IGF + WSF</b>	<b>PES UF</b>	<b>Ceramic UF</b>	<b>ZwitterCo UF</b>	<b>RO</b>	<b>MVC</b>	<b>MD</b>	<b>OARO</b>	<b>Units</b>
Energy cost									kWh/bbl
Energy cost	-	-	-	-	-	-	-	-	\$/bbl

<b>TOTAL</b>	0.001	0.003	0.003	0.006	0.035	0.318	0.250	0.245	\$/bbl
--------------	-------	-------	-------	-------	-------	-------	-------	-------	--------

<b>Bartholomew et al. (2017) [98]</b>	<b>TDS (mg/L), Recovery</b>	<b>kWh/m<sup>3</sup></b>	<b>\$/bbl</b>
OARO	140k, 50%	19.3	\$0.25
MVC	150k, 50%	25	\$0.32
RO	35k, 50%	2	\$0.03

<b>Membrane Distillation</b>		
	kWh/bbl	\$/bbl
Cassard and Park [59]	3.1	0.25

<b>Conversion factors</b>	
3.785	L / gal
42	gal / Bbl
7.48	gal / cu ft
5.62	cu ft / Bbl
159	L / Bbl
1.195	gr mol / scf
42.21	gr mol / scm
454	gr / lb
1.00E+06	scf / MMscf
2633	lb mol / MMscf
14.7	psi / atm
1.013	bar/atm
3.14159	pi
3,600	seconds / hour
1,440	minutes / day
24	hours / day
365	days/year
60	minutes / hour
60	seconds / minute
3.2808	ft / m
12	inch / foot
144	in^2 / ft^2
1000	mm / m
100	cm / m
1,000,000	micron/m
10,000	micron/cm
25.4	mm / inch
35.31	cu ft / cu m
264	gal / cu m
1,000	L/cu cm
1,000	L/cu m
28.32	L/cu ft
5.62	cu ft / Bbl
9.81	g constant
1.34	HP / kilowatts
0.4327	ft water / psi
3.415	BTU/hr / Watt
3,412	BTU / kWhr
100,000	Pa / bar
1,000	gr / kg
1,000	cc / L (or mL/L)
1,000	L/m3
1,000,000	cc/m3
1	Pa/(N/m2)
1	N/(kgm/sec2)
1,000	mg/gr
3.60E+06	Joule/kW

**4.5. Comparison of OARO energy consumption to other brine treatment processes**

The energy consumption is a key metric for assessing the effectiveness and economic feasibility of the OARO process relative to state of the art evaporative processes, such as MVC. Fig. 10 provides literature reported energy consumption values for RO, MVC, and our OARO simulations at a feed pressure of 65 bar and a membrane area per module of 10 and 20 m<sup>2</sup> for recoveries of 35 and 50%, respectively. RO energy consumption ranges from 1 to 2 kWh per m<sup>3</sup> of produced water for brackish (~5 g/L TDS) and seawater (35 g/L TDS) at a 50% recovery [7]. MVC energy consumption ranges from 11 to 25 kWh per m<sup>3</sup> of produced water for seawater (35 g/L TDS) to high salinity brines (150 g/L TDS) at recoveries of 35 to 50% [1,6,31]. The OARO energy consumption is estimated as 2.9 to 3.7 kWh per m<sup>3</sup> of produced water for feed TDS of 60 g/L at 35 and 50% recovery, respectively. At a higher feed TDS of 140 g/L, these values increase to 12.4 and 19.3 kWh per m<sup>3</sup> of produced water for recoveries of 35 and 50%, respectively.

Misc, spares, maintenance

TABLE 4  
Solid Waste Disposal

SOLID WASTE:	Quantity per train	Extended Quantity of Elements	Assumed Life	Annual element Replacements	Disposal Unit wgt. (d)	Extended (Lbs/year)	Σ (tons/year)	Comments
SRU Membranes (a)	7,854	15,708	5	3,142	35	109,956	55	Parker 40" x 2.5" FulFlo Mega Bond Plus or Honey Comb, 20 micron Asahi Microza UNA-620A
SRU CIP Cartridge filters (b)	1,304	2,608	1	2,608	2	5,216	3	
MF Membranes (c)	1,584	6,336	7	905	65	58,834	29	
Subtotal							87	
Allowance for staff @ 110 lbs/person/workday(e)							0	
Total Solid Waste Allowance							87	

NOTES:

- (a) U.S. Bureau of Reclamation, C. Bartels, R. Bergman, et al; Industry Consortium Analysis of Large Reverse Osmosis/Nanofiltration Element Diameters, Desalination and Water Purification Research and Development Report No. 114, Agreement No. 03-FC-81-0916,
- (b) CIP only; individual element is ~1.5 lbs, each (1.54 for Avasan AVS 20M40); Assume used/drained weight of 2 lbs.; come individually bagged, 12 per carton.
- (c) Shipping weight (with preservative) is 70lb; dry weight is 60 lbs; used 65 lbs as an average to account for build-up and residual liquid
- (d) Assumes gravity drain of free liquids in housing, prior to removal/disposal
- (e) Assumed to include disposal of packaging from work related activities; meals, etc.
- (f) Solid Waste is hauled in 27 cu. yd. bins which rent for \$11.50 per day and cost \$1662.93 per bin load to have hauled, emptied at the land fill and returned. Assumed 388 tons/year / (200lb/cu.yd/2000) = 3880 cu. yd/year; 3,880 cu. yd/year / 365 = 10.63 cu. yd/day; 3,880
- (g) Assumed unit cost for membrane elements are \$641.69, \$13.05 and \$2500 for the RO, RO CIP cartridge filters and MF/UF elements, respectively. Total membrane value is \$25,950,000

	Annual		Unit Cost	Cost
Process Water Waste	26,000	Mmgal	0	\$ -
Sanitary Waste Water	234,000	gal	0.25	\$ 58,500.00
Solid Waste	388	ton	630	\$ 244,521.00
Hazardous (listed) waste	0	ton	0	\$ -
Total cost/year				\$ 303,021.00

Existing Kuparuk STP - Actual Flows [1]			Kuparuk STP Debottleneck (Req) kBWPD			Kuparuk STP Debottleneck w/ MF & SRU kBWPD			Kuparuk Expansion kBWPD		
Flow (kBWPD)			Flow (kBWPD)			Flow (kBWPD)			Flow (kBWPD)		
Days per Year			Days per Year			Days per Year			Days per Year		
185	60	120	185	60	120	185	60	120	185	60	120
Winter	Breakup	Summer	Winter	Breakup	Summer	Winter	Breakup	Summer	Winter	Breakup	Summer
688			999	1031	17	989	1021	1015	197	221	218

	kBWPD	
Existing Kuparuk STP - Actual Flows [1]	688	\$ 303,021.00
Kuparuk STP Debottleneck (Req) kBWPD	1000	\$ 440,437.50
Kuparuk STP Debottleneck w/ MF & SRU kBWPD	1000	\$ 303,021.00
Kuparuk Expansion kBWPD	1000	\$ 303,021.00
Kuparuk Expansion w/ MF & SRU kBWPD	210	\$ 303,021.00

**Chemical Cost Summary including results from the pilot study**

**Reagent Prices**

REAGENTS:	Active Conc (%wt)	Price	Price Basis*	Sp. Gravity Product (gr/cm3)	Density Product (lb/gallon)	Specific Price Active Ingredient (\$/kg)	Molar Mass of Active Ingredient (g/mol)
Ammonium bisulfite	60%	\$ 4.50	\$/gallon	1.86	15.5	\$ 1.06	115.11
Sodium metabisulfite	100%	\$ 1.62	\$/lb	-	-	\$ 3.56	104.06
Sodium hydroxide	100%	\$ 0.35	\$/lb	-	-	\$ 0.77	40.00
Citric acid	50%	\$ 8.00	\$/gallon	1.24	10.3	\$ 3.40	192.12
Hydrochloric acid	38%	\$ 5.00	\$/gallon	1.18	9.8	\$ 2.94	36.46
Bleach	12.5%	\$ 0.10	\$/lb	1.20	10.0	\$ 1.76	74.44
Scale inhibitor	60%	\$ 16.00	\$/gallon	1.06	8.8	\$ 6.64	-
Biocide (DBNPA)	20%	\$ 32.00	\$/gallon	1.01	8.4	\$ 41.80	241.87
Corrosion inhibitor	80%	\$ 14.00	\$/gallon	0.85	7.1	\$ 5.43	-

\* gallon or lb of product, not active ingredient

**Unit Conversion References**

454	gr/lb
3785	cm3/gallon
3.785	L/gal
42	gal/bbl
6.29	bbbl/m3
2.2	lb/kg

**Results from pilot study**

- TEA Spreadsheet updates with piloted parameters
  - o Flux: 20 LMH
  - o Operating pressure: keep the same dP assumptions
  - o Recovery: 99%
  - o Cleaning uptime: Assume 1 hr cleaning/day ~95% uptime.
  - o Chemicals- updated cleaning schedule and cleaning concentrations
    - i. pH 2 HCl: Add 54.75 g (approx. 47 mL) of 38% HCl solution to 15-gal water
    - ii. pH 12 Caustic: 170g of NaOH flake and 188 L bleach to 15 gal solution
    - iii. Not sure how much volume of water we assumed for CIP systems

**UF Cleanings**

System Basis 20,000 BWPD feed water

System flowrate	583	gpm
CIP Residence Time	10	min
CIP Volume	5833	gal
CIP Volume	22079	L

Alkaline CIP	
NaOH Concentration	0.03 mol/L
NaOH Dose	26.50 kg-active/CIP
Cost NaOH/CIP	\$ 20.40 \$/CIP-NaOH
Bleach Concentration	100 mg/L
Bleach Dose	2.21 kg-active/CIP
Cost Bleach/CIP	\$ 3.89 \$/CIP-Bleach
<b>Alkaline CIP</b>	<b>\$ 24.29 \$/CIP</b>

Acid CIP	
HCl Concentration	0.01 mol/L
HCl Dose	8.05 kg-active/CIP
Cost HCl/CIP	\$ 23.69 \$/CIP-HCl
Citric Acid Concentration	1000 mg/L
Citric Dose	22.08 kg-active/CIP
Cost Citric/CIP	\$ 75.18 \$/CIP-Citric
<b>Acid CIP</b>	<b>\$ 98.87 \$/CIP</b>

	PES UF	Ceramic UF	ZwitterCo	units
CIP Weekly Frequency	14	14	7	#/wk
Total CIP Duration	3	3	1	hr
Uptime	75%	75%	96%	%
<b>Annual Cost</b>	<b>\$ 154,020</b>	<b>\$ 89,655</b>	<b>\$ 44,828</b>	<b>\$/yr</b>
<b>Specific CIP Cost</b>	<b>\$ 0.0281</b>	<b>\$ 0.0164</b>	<b>\$ 0.0064</b>	<b>\$/bbl</b>
Ex-Uptime CIP Cost	\$ 0.0211	\$ 0.0123	\$ 0.0061	\$/bbl

(Includes CEBs for CUF)

Alkaline CIP - PES UF	
NaOH Concentration	0.03 mol/L
NaOH Dose	26.50 kg-active/CIP
Cost NaOH/CIP	\$ 20.40 \$/CIP-NaOH
Biocide Concentration	100 mg/L
Biocide Dose	2.21 kg-active/CIP
Cost Biocide/CIP	\$ 92.30 \$/CIP-Bleach
<b>Alkaline CIP</b>	<b>\$ 112.70 \$/CIP</b>

**Desalination Cleaning Chemicals - Literature**

C. Fritzmann et al. / Desalination 216 (2007) 1-76

Table 24  
Operational cost [63]

Component	UF + 2-stage SWRO [US\$/m <sup>3</sup> ]	In line coagulation + 2-stage sand filtration + 2-stage SWRO [US\$/m <sup>3</sup> ]
Investment cost	0.2377	0.2452
Replacement for UF cartridges/ sand filtration material + cartridges	0.0234	0.0026
Replacement RO membranes	0.0161	0.0275
Process and cleaning chemicals	0.0411	0.0488
Power consumption	0.1773	0.1712
Spare parts	0.0382	0.0411
Manpower - O&M	0.0286	0.0360
Overhead	0.0196	0.0196
Total water cost	0.5819	0.5921*

\*Not considering any penalties for alternative water supply in case of plant under-performance caused by pre-treatment.

Table 3 reports the economics of the process. The treatment cost excluding the revenue derived has been calculated as being approximately \$10/1000 gal (\$2.65/m<sup>3</sup>) of feed treated.

Table 3  
Membrane treatment of fatty acid wastewater (costs in 1989 US\$, adapted from Dangel et al. [10])

Item	Cost (\$)
Capital costs including engineering, equipment and installation	1 500 000
Amortized capital (annual)	220 000
Membrane replacement (annual)	54 000
Labor (annual)	80 000
Electricity (annual)	25 000
Cleaning chemicals (annual)	6 000
Total annual costs (operating+amortized capital)	385 000
Value derived from fatty acid recovered	68 000
Net annual cost	317 000

A manufacturer of fatty acids generates 60 000-105 000 gal (230-400 m<sup>3</sup>) of wastewater per day containing 3000-4000 mg/l fats, oil and grease (FOG), primarily in the form of emulsified fats [10]. The local

Table 34  
Specific chemical consumption and costs for the Al-Fujairah desalination plant [61]

Chemicals	Conc. ppm	\$/kg	g/m <sup>3</sup> (perm.)	\$/m <sup>3</sup> (perm.)	\$/day
Chlorine	3	0.55	0.08	0	0.35
Ferric chloride	3	0.27	20.58	0.00557	959.4
Cationic coagulant	0.85	1.94	2.33	0.00453	779.33
Sulfuric acid	25	0.18	68.63	0.0124	2132.52
Antiscalant	1.05	1.94	2.65	0.00515	886.67
Sodium bisulfite	6	0.5	0.63	0.0003	54
<b>Total</b>				<b>0.03</b>	<b>4812.27</b>

This sheet provides a calculation of the amount of caustic required to raise the pH of produced water to 10.

Objective: raise the pH to 10.0  
Assuming initial pH of 7

Produced water flow rate	
produced water flow rate	20,000 bbl/day
fluid volume	3,180 m3/day
fluid volume	3,179,650 L/day

Ca(OH) <sub>2</sub> precipitation	
initial Ca conc (elemental Ca)	5.000 mg/L
initial Ca conc (elemental Ca)	5.00 gr/L
initial Ca conc (elemental Ca)	0.125 mol/L
moles NaOH required	0.250 mol/L
NaOH required	10.0 gr/L

Mg(OH) <sub>2</sub> precipitation	
initial Ca conc (elemental Mg)	953 mg/L
initial Ca conc (elemental Mg)	0.95 gr/L
initial Ca conc (elemental Mg)	0.039 mol/L
moles NaOH required	0.078 mol/L
NaOH required	3.1 gr/L

Acid titration	
initial pH	7.0
final pH	11.0
pH change	4.0
NaOH required	1.00E-04 moles/L
NaOH required	4.00E-03 gr/L

Boric acid / Borate ion conversion	
initial B conc (elemental B)	200.0 mg/L
initial B conc (elemental B)	0.20 gr/L
initial B conc (elemental B)	0.0065 mol/L
moles NaOH required	0.0065 mol/L
NaOH required	0.26 gr/L

Total NaOH required (Ca, pH, B)	
Total NaOH required	13.4 gr/L
Total NaOH required	42,611,047 gr/day
Total NaOH required	42,611 kg/day
Total NaOH required	93,744 lb/day
Total NaOH required	34,216,671 lb/year
NaOH unit cost	700 \$/short ton
NaOH unit cost	0.35 \$/lb
Total NaOH cost	11,975,835 \$/year
Total NaOH cost	1.64 \$/bbl

Conversion factors	
	3.785 L / gal
	42 gal / Bbl
	7.48 gal / cu ft
	5.62 cu ft / Bbl
	159 L / Bbl
	1.195 gr mol / scf
	42.21 gr mol / scm
	454 gr / lb
	2.20 kg/lb
	3.2808 ft / m
	12 inch / foot
	144 in <sup>2</sup> / ft <sup>2</sup>
	1000 mm / m
	100 cm / m
	1,000,000 micron/m
	10,000 micron/cm
	25.4 mm / inch
	35.31 cu ft / cu m
	264 gal / cu m
	6.29 Bbl / cu m
	1,000 L/cu cm
	1,000 L/cu m

Molecular weights (gr/mol)	
Ca	40
Mg	24.3
OH	17
H	1.004
O	16
Ca(OH) <sub>2</sub>	74
Na	23
NaOH	40
B	10.8
Boric acid H <sub>3</sub> BO <sub>3</sub>	30.9
Borate ion H <sub>2</sub> BO <sub>3</sub> <sup>-1</sup>	29.9

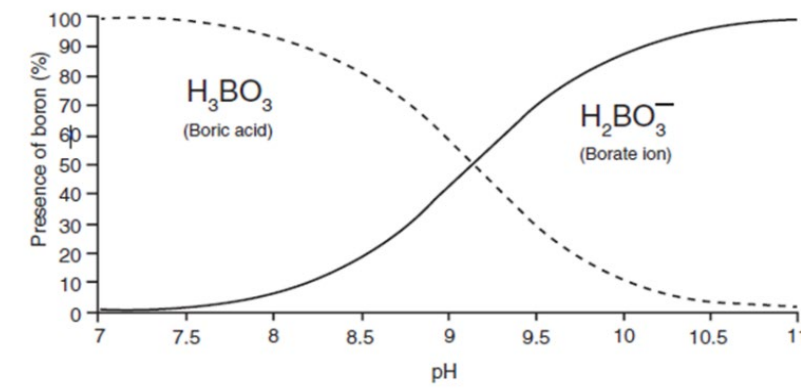
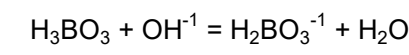

Fig. 1—The behavior and chemical composition of boron varies in an aqueous environment. Borate ions dominate at higher pH, and boric acid dominates at lower pH.



Feed water1 module characteristics (Water Input)

Cations				Anions					
Major	Metals	Total	1982.213	Major	Metals	Total	1982.213		
Cation	mg/L	ppm CaCO <sub>3</sub>	%	meq/L	Anion	mg/L	ppm CaCO <sub>3</sub>	%	meq/L
H(+)	0.0004	0.021	0.002	0.0004	OH(-)	0.004	0.12	0.001	0.0002
[Ca]	4,587.20	11,445.7	1,144.57	228.914	HCO <sub>3</sub> (-)	483.164	395.925	39.592	7.918
[Mg]	953.200	3,921.83	392.183	78.437	CO <sub>3</sub> (-)	0.879	1.464	0.146	0.029
[Na]	38,041.0	82,734.5	8,273.45	1,654.69	[Cl]	70,169.8	98,962.6	9,896.26	1,979.25
[K]	821.500	1,050.56	105.056	21.011	[NO <sub>2</sub> ]	0.000	0.000	0.000	0.000
[Ba]	3.100	2.257	0.226	0.045	[NO <sub>3</sub> ]	0.000	0.000	0.000	0.000
[S]	539.300	615.499	61.550	12.310	[Br]	0.000	0.000	0.000	0.000
NH <sub>4</sub> (+)	0.000	0.000	0.000	0.000	H <sub>2</sub> SO <sub>4</sub> (-)	0.002	0.0009	0.00009	0.00002
					SO <sub>4</sub> (-)	413.999	430.948	43.055	8.611

Other total species: [NH<sub>4</sub>+] 0.00 mg NH<sub>4</sub>/L, Fe-tot 13.80 mg Fe/L, Mn-tot 1.90 mg Mn/L, [PO<sub>4</sub>-] 0.00 mg PO<sub>4</sub>/L, [F] 0.000 mg FA, [S] 7.000 mg S/L, [SO<sub>3</sub>] 0.00 mg SO<sub>3</sub>/L, [SO<sub>4</sub>] 414.00 mg SO<sub>4</sub>/L, Silica (reactive) 0.000 mg SiO<sub>2</sub>/L, Boron 222.700 mg B/L

General: pH 6.40, m-Alk 405.0 ppm CaCO<sub>3</sub>

Temperature / Pressure: T Min. 41.00, T Ave. 85.00 °F, T Max. 86.00, P. gage 0.0 PSI

Equilibrium - Ionic balance: Balance on: Na+, Electroneutrality -7E-7 meq/L

Flow rate: Volumetric 1,000.0 gpm, Mass 538,600 lbs/h

Hydraulic: Density 1.07564 g/cm<sup>3</sup>, Viscosity 1.027 cP

Disolved gases (mg/L): CO<sub>2</sub> 38.816, NH<sub>3</sub> 0.000, H<sub>2</sub>S 4.074, H<sub>2</sub>SO<sub>3</sub> 0.000

Salinity: TDS (29.44°C) 117,194 mg/L, Dry residue (180°C) 116,923 mg/L, Ionic strength 2,401 mol/L, TIC 8.82 mmol/L, Conductivity (25°C) 130,339 μS/cm, Resistivity 0.000008 Mohm.cm

The calculation of "Dynamic Viscosity" is out of its range of validity: 0 <= TDS <= 40 000 (mg/L)

Examining this water analysis the following components will represent a demand for Sodium hydroxide (NaOH) - carbon dioxide, bicarbonate and magnesium plus a small demand for the removal of iron, manganese and sulfide.

The following reactions would be the primary reactions for raising the pH:-

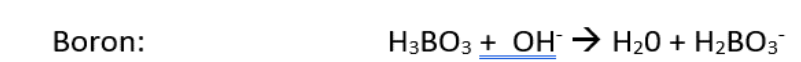
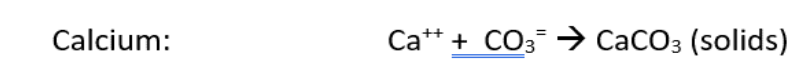
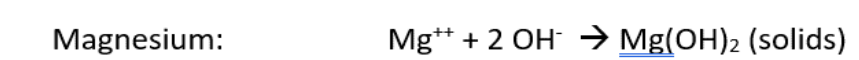
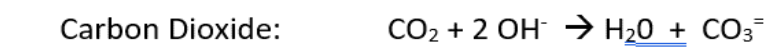

Additional caustic would be required for ionization of silica if present (not reported).

1000 gpm
20,000 BWPD
583 gpm

Estimated Caustic Demand to raise the pH from 6.4 to pH 11 for 1000 gpm of water

Based on a 1000 gpm feed water flow the solids generated would be 1,633 lbs per hour being primarily due to magnesium hydroxide precipitation.

Injected product	lbs/h	
	4,478.46	pure NaOH, dry material
PW feed - assumed	1,000	gpm
PW feed - assumed	34,286	BWPD
PW feed - actual	20,000	BWPD
dry NaOH consumption	2,612	lbs/hour
dry NaOH consumption	28,499	kg/day
price	0.77	\$/kg-active
NaOH cost	21,944	\$/day
NaOH cost	1.10	\$/bbl

**APPENDIX B**  
**BENEFICIAL REUSE UPTAKE – EXTERNAL FACTORS**  
**TECHNO-ECONOMIC ANALYSIS**

**DATE SUBMITTED**

September 14<sup>th</sup>, 2022

**PROJECT PERIOD**

February 1<sup>st</sup>, 2020 - May 31<sup>st</sup>, 2022

**“Fouling-resistant, chlorine-tolerant zwitterionic membranes for treatment of produced water in the Permian Basin”**

**RECIPIENT ORGANIZATION**

ZwitterCo, Inc.

85 Bolton St.

Cambridge, MA 02140

DUNS Number: 081215694

**SUBMITTED TO**

U.S. Department of Energy

National Energy Technology Laboratory

# Appendix B

## Table of Contents

1.0 Introduction	3
2.0 Current Cost Structures	3
2.2 Produced Water for In-field Reuse	7
2.3 Transportation	8
2.4 Disposal	8
2.5 The Economic Case for Desalination in Permian	9
3.0 Raw Produced Water Quality	9
3.1 New Mexico	15
3.2 Texas	16
4.0 Water Quality Required for Beneficial Reuse	18
4.1 Agriculture	18
4.2 Mining	22
4.3 Rangeland	23
4.4 Others (Power plants, Refining, Pecos River relief for NM, Frac sand washing)	24
5.0 Freshwater Quality Currently Used	49
5.1 Quality of groundwater currently	49
5.2 PW blending	50
6.0 Source and Demand Geography	51
7.0 Demand Quantity	52
8.0 Conclusions	56
References	57



## 1.0 Introduction

Water management is an important aspect of the development of unconventional formations in the United States onshore and, in particular, the Permian Basin of west Texas and southeastern New Mexico. Unconventional formations do not have sufficient permeability to flow oil and gas economically with traditional vertical completions. The application of horizontal completions and hydraulic fracturing creates enough surface area for the ultra-low permeability formations to flow hydrocarbons. The hydraulic fracturing, or hydraulic fracturing, is performed in a series of stages along the horizontal wellbore when high pressure water, sand and chemicals crack the rock open. The sand is left in the fracture and holds the space open for flow. Water management is about sourcing and delivering source water to the well site for hydraulic fracturing, and delivering the produced water to either a disposal well or allowing it to be treated and reused.

The Permian Basin is the largest and most economically viable oil basin globally. It is also notable in that the wells typically produce back as much or more water in the life of the well than was used in the hydraulic fracturing. Currently, the majority of the water is disposed into deep saline reservoirs and a smaller portion of the produced water is reused in subsequent hydraulic fracturing of wells. This report researches the potential for beneficial reuse outside of the oilfield application. For the normally high salinity produced water of the Permian to be used outside of oilfield operations, the water must be desalinated, removal of the majority of the salinity or total dissolved solids (TDS). Additionally, a variety of economic, regulatory and technical challenges must be overcome.

This Appendix is organized as follows:

- The current water management costs and the case for desalination and beneficial reuse.
- Summary of produced water quality in the Permian basin.
- The volumes needed and the water quality needed by the user is analyzed.
- Current practices and desalination technologies are reviewed.

The biggest challenge of beneficial reuse of produced water is the economic challenge. To keep costs low, a high volume, perhaps 100,000 barrels per day or larger, centrally located plant could benefit from the economies of scale. The plant could be located along an existing produced water system and near the end user of the desalinated water to reduce additional transportation costs. New Mexico has the highest water management costs by industry in Permian and is the likely location of the first desalination plants. Irrigation use or discharge into the Pecos River could match the high volumes of a large plant. Municipal or other industrial applications are secondary potential users.

Effective pre-treatment of the produced water can help keep the overall treatment cost lower. Effective desalination not only will remove the TDS from 100,000+ mg/L to less than 500 mg/L, but it will also remove any minor concentration of hazardous elements to below the threat level. The demonstration of the pre-treatment effectiveness is an important aspect of the second phase of this project. Overcoming technical challenges include demonstrating that pre-treatment can be achieved with actual produced water in a field setting. Achieving high quality water and performing sufficient water quality testing will also be important to obtaining regulatory approvals.

## 2.0 Current Cost Structures

This section provides an overview of cost elements that are important in the introduction of new technology for application in the Permian Basin. The section starts with a discussion of what is currently happening in the Permian in terms of:

- Fresh water sourcing for various end case uses as listed below
- Where are the operating companies getting the fresh water from?
- Groundwater, municipalities, aquifers, freshwater sourcing for fracturing water make-up

- What are the current costs associated with produced water for in-field use?
- What is the cost of trucking versus pipeline?
- What are the cost differences for the various modes of water transport?
- What are the costs for disposal?
- What does it cost to operate an SWD injection well?
- What is happening in terms of permitting?
- What are the costs of permitting and what are the trends in cost?

These costs are provided for both NM and TX with an emphasis on NM. Costs are going up due to pressurization. Water volumes are not a focus of this section. Demand Quantity is discussed in section 6. Costs to source water across the Permian Basin vary widely. Several factors are key to explaining water sourcing costs locally:

- Availability of surface water (rivers & lakes)
- Availability of groundwater reservoirs
- State or local laws and regulations
- Water quality needed (fresh, brackish or saline produced water)
- Transportation infrastructure and proximity

West Texas and southeastern New Mexico are generally arid. Water resources are limited. Groundwater and surface water, rivers and lakes, are the primary water sources, but both have limitations.

In the two most important counties in New Mexico for oil and gas development, here are the sources of the water used in 2015.

<u>County</u>	<u>Surface Source (%)</u>	<u>Ground water (%)</u>
Eddy	60.5	39.5
Lea	0.0	100.0
2-Counties combined	27.0	63.0

Source: New Mexico State Engineer Office water use report

Average annual rainfall for key Cities in Permian & other cities

<u>City</u>	<u>Annual inches</u>
Odessa, TX	14.7
Pecos, TX	11.6
Carlsbad, NM	13.4
Jal, NM	13.9
New York, NY	46.2
Houston, TX	45.3

Data source: usclimatedata.com [18].

There are few lakes or rivers that have significant volumes of water. State and local regulations often restrict use of surface water.

Groundwater is also limited. Historic irrigation for farming has significantly depleted some of the region’s key aquifers. The Ogallala aquifer, also known as the high plains aquifer, covers parts of eight states and is the largest aquifer in the

US. The Ogallala has seen substantial depletion since 1950, see graphic below. It is representative of most aquifers in the Permian region.

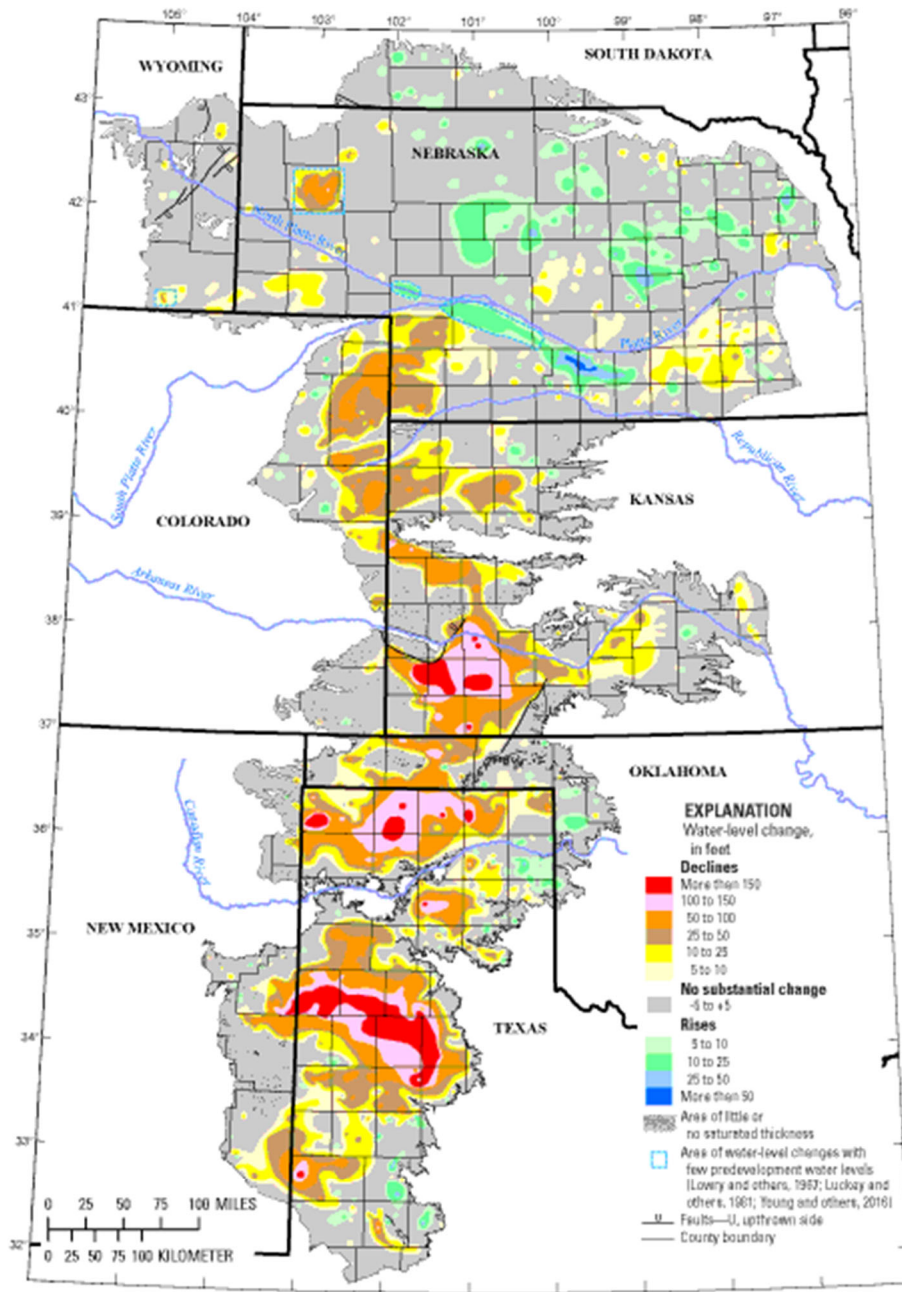

High Plains aquifer water-level changes, predevelopment (about 1950 to 2015). Figure 1 from [USGS SIR 2017-5040](https://pubs.usgs.gov/sir/2017/5040/) (Public domain.) [19]

Groundwater rights in Texas are property of the surface owner, unless the water rights have been segregated from the surface ownership. Permian Basin property owners have been selling groundwater to the oil and gas industry more significantly since the advent of unconventional development around 2012. Over recent years, the cost of source water for the oil and gas industry has probably averaged about 50 cents per barrel. The cost is higher when oil and gas is booming and lower when it is not. Local supply and demand will cause prices to vary.

Municipal wastewater is a non-traditional water source in Permian. However, in recent years municipal wastewater is being used instead of groundwater or surface water. For example, Pioneer Natural Resources signed an 11 year deal for \$117 million with the city of Odessa, TX in 2016 [Pioneer Odessa water deal](#). The long-term deal to buy a portion of the city's municipal waste water is estimated to translate to about 26 cents per barrel.

Pioneer also signed an agreement in 2018 with the city of Midland, TX to acquire its municipal wastewater. [Pioneer Midland water deal](#). Pioneer will buy water from Midland for 20 to 28 years, upgrade the existing city plant for about \$130 million and pay about \$2.5 million per year for water. The deal is expected to equate to about 13 cents per barrel, without considering the present value for the upfront payments. These long-term commercial deals with Odessa and Midland are clearly at a lower cost per barrel than the typical short-term deal to buy water from a surface owners groundwater well that may have averaged 50 cents per barrel.

Other cities in the area, such as Carlsbad, NM, are known to have sold their wastewater to a variety of industries, including for oilfield use.

Groundwater in New Mexico is owned by the state and there are complex set of regulations. Jurisdictions may include federal, state, county and tribes. Groundwater in New Mexico seems generally less available and that is reflected in commercial pricing. According to a company that aggregates water data in the region, Northern Lee and Eddy Counties have had spot water costs around 85 cents to \$1 per barrel in early 2020. Another industry source stated that prices for source water in Lea County were about \$1.40/BW in 2017 and 2018. As the oil and gas industry has increased produced water reuse for their operations, demand for groundwater has decreased. The same industry source said that prices near Carlsbad were approximately \$1/BW in early 2020.

Since surface water rights are more complex and have been held long-term by surface owners, oil and gas producers in Permian rarely use surface water for hydraulic fracturing.

Often, oil and gas blends fresh or brackish water with the reused produced water. The prices for fresh or brackish water for oil and gas (O&G) do not vary substantially. Since O&G are the primary market for source water in the Permian region, and since they can use fresh or brackish interchangeably, there is generally no appreciable difference in pricing.

It is also widely known that source water is being produced in Loving and Pecos Counties in Texas and transferred across to New Mexico for use for the oil and gas industry. This practice is significant in keeping the state line area's prices lower than northern Eddy and Lee Counties in New Mexico. Since source water pipelines are not generally available to transfer source water across counties, local supply and demand drives water pricing.

Water costs for agriculture within the Carlsbad Irrigation District can range from 0.5 cents per barrel based on the current 2020 allotment to 0.3 cents per barrel for the maximum allotment. This is based on water rights holders paying \$87 per acre in 2020 and the current allotment of 2.3 acre-feet. The maximum allotment is 3.697 acre-ft per acre of water rights. This information was from the Carlsbad Irrigation District office in May 2020.

Inquiries to mining concerns in Permian indicate that most own groundwater rights. Therefore, their cost of water is associated with the purchase of the rights and cost to pump the water. Most do not purchase water commercial as many oil and gas producers do. It is generally accepted that the oil and gas industry generally pays more for water than other industries, perhaps because it is for a short term use for a group of local wells.

There are very limited permanent source water pipeline networks for oil and gas in Permian. Pioneer Natural Resources is known to have connected the Odessa municipal wastewater source to its water network. The Midland wastewater source will be connected when the plant upgrade is complete. But outside of these examples, there are few large scale fresh or brackish water systems. The majority of the major water midstream pipeline systems announced in Permian are for produced water transferring to disposal wells or recycling centers.

Thus, the majority of source water is transferred to the frac well site via temporary lines referred to as lay flat hose. These temporary lines are often 12 inch in diameter to handle the high volumes for short periods of time. When the completions (hydraulic fracturing) are complete, the temporary line is removed. The effect of limited source pipeline networks is that pricing for source water in northern Lee and Eddy Counties is probably the highest in Permian.

## 2.2 Produced Water for In-field Reuse

Generally, economics drive the decision-making to reuse produced water instead of disposing it in a permitted disposal well. The desire to be more sustainable is also a factor. Almost all of the large producing companies have stated goals to minimize fresh water use and increase recycling.

The Ground Water Protection Council report on produced water (starting on page 158) lists these factors as the key economic factors for beneficial reuse:

1. Treatment costs
2. Transportation, infrastructure and logistics
3. Contracts, agreements, long-term commitments, royalties and sunk costs
4. Energy needs
5. Market factors
6. Solids management
7. Water rights
8. Relative economic feasibility

The economics for reuse are positive when the cost to transfer, store and treat the reused produced water are less than the cost of water sourcing, transfer and disposal. Typical source and disposal costs are:

- Source water for hydraulic fracturing - 50 cents/BW (Range from 25 cents to \$1)
- Transfer source water via temporary layflat hose - 20 cents/BW (Can be up to \$1.50/BW if trucked)
- Transfer produced water to disposal well - 5 cents/BW (Usually via short line)
- Disposal cost at commercial disposal well - 50 cents/BW (Can range from 40 cents to \$1/BW)

The costs above include amortized CAPEX and operating expenses. Thus, the typical all-in source to disposal cost could be about \$1.25/BW.

For reuse, the costs may be broken down as follows:

- Storage of produce water in large impoundment - 25 cents/BW (largely a function of how long hydraulic fracturing continues in the area)
- Treatment in the impoundment - 25 cents/BW (commonly aeration to control bacteria and handling solids)
- Transfer produced water to frac site - 50 cents/BW (May include permanent pipelines and temporary lines and is a function of distance and volumes over time)

Thus, the costs in the above reuse case total \$1.00/BW, just under the typical cost to source, transfer and dispose. The transfer cost with reuse can be more complex since the produced water is not always close to the frac site the way groundwater sourcing may be. Therefore, to transfer the produced water to changing locations often relies on a water pipeline system and the amortization of the capital costs over time and barrels reused. If there is not sufficient volumes of water to transfer to keep the costs per barrel low enough, the pipeline system can not be economically justified. In

other words, if the projected capital and operating costs of the reuse plan exceed the status quo of local sourcing and local disposal, then the potential reuse project is never developed.

## 2.3 Transportation

Transport of water is involved in the sourcing phase before hydraulic fracturing and transport of the produced water to a disposal well or reuse in a frac well. There are three ways the water is conveyed typically: Temporary surface lines, buried permanent lines and trucking.

Temporary surface lines are employed when the water transfer is only needed for short time periods, perhaps one to three months. This is especially common when sourcing water “the last mile” to a frac site. It is often not practical to run a permanent line to a well pad when the water is only sourced for the duration of the completions. A flexible hose called layflat is often used in this application. The layflat hose is easily laid out and rolled up to be used at the next pad or well location. The layflat hose is frequently provided as a service where the cost is based on distance and time used. Typically, the layflat hoses will have a capacity to deliver water to the frac location at a peak rate of 50,000 BWPD or more.

Permanent buried water pipelines are used when water transfer is expected for years and the volumes of water justify the capital investment. Many producing companies in Permian have the majority of their new wells connected to disposal or reuse facilities via permanent pipe. In some cases, the producing companies have long term agreements with water midstream companies that gather and dispose of produced water.

Trucking is generally used for produced water when water volumes are low. Some unconventional areas, like the Eagle Ford in south Texas, normally have low produced water volumes. In these cases, the limited water flow rates do not justify the capital cost of water pipelines. Water trucks normally have a capacity of 120 barrels and the cost per barrel to transport can be approximately \$1 to \$2 per barrel, depending on distance trucked and potential wait times to unload. Rarely does trucking make sense for delivering source water for hydraulic fracturing. Also, many companies in Permian are trying to reduce the number of trucks on the road as a way to reduce community impacts.

## 2.4 Disposal

Saltwater Disposal wells (SWDs) have been a reliable method of disposal of produced water in Permian for decades. With the advent of unconventional production starting around 2011 in Permian, the produced water volumes and need for new SWDs have grown. SWDs are permitted through the Texas Railroad Commission and the New Mexico Oil Conservation Division of the Energy Minerals Natural Resources Department (EMNRD). The cost of commercial (third party owned) SWD disposal varies based on the demand for water disposal and the supply of SWD disposal capacity. Higher industry activity, drilling and completions, leads to more produced water. The supply of commercial SWDs has increased recently with the increased activity since 2017. There is variation in commercial disposal costs across the basin, but \$0.50 per barrel is often referenced as a typical cost.

In New Mexico, the regulators have greatly limited disposal into shallower disposal formations in recent years. The basis for restricting shallow disposal is that it might adversely interfere with offset oil and gas production in the horizon. Therefore, the majority of new SWDs in Lea and Eddy County are below the deepest producing formations. The higher cost deep wells require a higher cost per barrel to repay the capital. Thus, the highest disposal costs in Permian are in the northern active areas of Lea and Eddy Counties, and may approach \$1 per barrel.

Oil producing companies also often own their SWDs for their exclusive use, non-commercial SWDs. Their cost per barrel reflects the capital cost of the well, the operating costs of pumps and labor, and the amount of water injected over time.

Depending on the depth and capacity of a SWD, capital costs may range from \$2 million to over \$10 million. Operating costs typically range from \$0.15 to \$0.45 per barrel.

## 2.5 The Economic Case for Desalination in Permian

While desalination of produced water is not currently ongoing in Permian, there is a scenario where it becomes economically viable. The scenario is driven by continued high levels of water disposal that increase the disposal reservoir pressure to unacceptable levels. It is possible that the state regulators could step-in to limit new disposal wells or even reduce existing permit levels of injection. It is in this path that disposal costs could increase and tip the economics toward getting water out of the system with desalination and beneficial reuse.

The economics can be “boiled down” to this value proposition. If disposal costs by the producer plus the cost of source water are greater than treatment and transport costs for beneficial reuse, then desalination can be viable. With the large volume of produced water in Permian, it is possible to foresee disposal costs increasing to \$2 per barrel or more. It is unlikely that agriculture or other water users will be able to pay more than cents per barrel. Therefore, the value of desalination will be driven by saving disposal costs and could be from \$2 to \$3/BW in the future.

The cost of desalination could have a high variability, depending on the particular scenario. According to the 2017 Oklahoma Produced Water Study, a large-scale (100,000 BWPD), long-term (10-year) project could have total desalination costs of \$2.22 to \$2.52/BW, depending on salinity. More recently, a leading water treatment provider (Gradiant Corp.) thought that \$2/BW for partial desalination using counter flow reverse osmosis (CFRO) would be possible. Notably, the CFRO requires pretreatment for oil and selected suspended solids.

The formation of the New Mexico Produced Water Research Consortium (NMPWRC) in January, 2020 is evidence that the desalination scenario may be needed. NMPWRC is focused on exploring the possibility of reuse of desalinated produced water outside of the oilfield. The consortium is supported by New Mexico state agencies, university researchers and industry.

Both Texas and New Mexico regulators have already taken actions to limit disposal reservoirs or the maximum disposal pressures in attempts to limit disposal. These actions provide insight into the regulator’s concerns about the limitations of disposal reservoirs.

## 3.0 Raw Produced Water Quality

This section covers the subject of produced water quality. The composition and concentration of dispersed and dissolved contaminants is discussed here. Common analyses such as TDS, multi-ion analysis, pH as well as process parameters such as temperature are given. The concentration of BTEX, aromatic, hydrocarbon and organics are included. Substances such as BTEX, PHA, and NDT can cause swelling, weakening and failure of certain membrane materials.

Substances such as lithium, bromine and transition metals are included since they have potential for extraction, purification and sale. The market and pricing for these recoverable constituents is covered in Section 1. Section 2 (this section) covers the quality of the produced water and how much is found in the water as a function of location (geologic formation). Established and new technologies for extraction are covered in Section 8. Costs associated with different extraction technologies are summarized in Section 1.0 and discussed in detail in Section 8.0.

Produced water quality varies by formation and by location within a formation. The Wolfcamp formation in Midland, for example, has different formation water quality than the Wolfcamp formation in Lea County, New Mexico. This is not surprising given the complex geologic processes that have occurred in the Permian Basin over many millions of years. The industry has expended significant effort to understand the geology of the region since it can shed light on the location of rich hydrocarbon deposits. Many strategies have been employed by geologists in their quest for understanding. Study of formation water quality is one such strategy. As will be discussed, formation water quality and its variation from one location to another has been recently used to shed light on the geology and geologic processes

that have occurred. This information has helped to determine likely suitable locations where Zwitterco technology will have the greatest economic impact.

Produced water is highly complex and highly variable from one location to another and variable over the life of a well. Nevertheless, a framework for characterizing produced water has been developed over several years and is generally accepted across the E&P industry. The characterization of produced water starts with a recognition of dissolved versus dispersed (suspended) contaminants. Suspended contaminants are defined as those substances that can be removed by filtration of the water through a 0.45 micron filter. Occasionally a 0.2 micron filter is used depending on the application of the test. Suspended contaminants that are collected on the filter paper include insoluble liquids and mineral or organic solids. Padaki et al. [16] refer to four classes of oil components:

- aliphatic
- aromatic
- NSO (nitrogen, sulfur, oxygen) containing compounds (aka resins)
- asphaltene

In some applications the NSO fraction is referred to as “resins.”

These oil contaminants are detrimental to membrane filters used for desalination. Thus, they are an important part of the composition of produced water. It is anticipated that the Zwitterco membrane will remove these components.

The dissolved components are equally important since many reuse applications require low concentrations of salt in general and sodium in particular. A good place to start the discussion of the dissolved components of produced water is with a high-level overview across several basins in the US. Below is a chart showing the TDS for produced water across the US oil and gas industry. The chart is based on data from the United States Geological Survey (USGS) database. The link is given here: <https://www.usgs.gov/energy-and-minerals/energy-resources-program/>. The database was established decades ago and includes data from primary conventional recovery, waterflood recovery, and shale produced water. While the database is still in active use today, most of the data were collected prior to the recent shale activity. Therefore, produced water quality from shale developments in the last ten years or so is under-represented. This can be verified by looking at the number of data points in the Marcellus region in Ohio and Pennsylvania as well as the Eagle Ford in south west Texas. The number of datapoints for these shale developments is relatively small. The number of data points in the Permian and in central Oklahoma are, by comparison relatively large. This suggests that the data for all of these regions represent relatively old conventional and waterflooding activities. Nevertheless, as will be discussed, shale formations are often hydraulically connected to underlying conventional sandstone and carbonate reservoirs. Many conventional reservoirs contain hydrocarbons that were expelled, as bitumen, from the overlying kerogen shale. Thus, water quality data for conventional reservoirs tend to correlate with water quality of their bounding shales. As the chart shows, the Permian has a wide range of produced water quality which spans the range of 50 mg/L to above 200 mg/L.

### **Water Temperatures into Water Systems in Permian**

The water temperature as it enters the water treatment facilities is important as it may affect the treatment process or the design of materials. In some cases, particularly hot fluid surface temperatures are problematic for the common use of plastic poly water pipelines.

The surface or wellhead flowing temperature (WFT) of a given well is driven by a variety of factors, including:

- The producing reservoir formation temperature which itself is a function of depth
- The flow rate of the well - more liquids and less gas create hotter WFTs
- Artificial lift - Electrical Submersible Pumps (ESPs) don't impact temperatures much, but gas lift creates a cooling effect. Both ESPs and gas lift are commonly used in Permian.
- Tubing size - the tubing diameter combined with the flow rate determine the fluid velocity and impact the cooling rate as the fluids rise in the wellbore.

There is very little public information on wellhead temperatures via web searches or even in industry papers such as the Society of Petroleum Engineers. A couple of industry veterans agreed that individual wells may range from 70 to 150



degrees F at the surface, depending on the factors mentioned above. Since the formation temperatures near surface are usually 60 or 70 degrees F, that establishes a lower bound of temperatures. The upper limit is a function of heat transfer as the fluids flow up the wellbore and cool down.

Fluids from individual wells come together at a tank battery to separate oil, gas and water. The water may flow in buried or above-ground pipes from the tank battery to the central treatment location. If transferred in buried pipe, the fluids may cool. If transferred in above ground pipes, the ambient temperatures may heat or cool the water.

One major water midstream company active in Eddy and Lea Counties in New Mexico indicated that their system normally has water temperature around 90 to 110 degrees F.

**Produced Water Salinity from the USGS Database:**

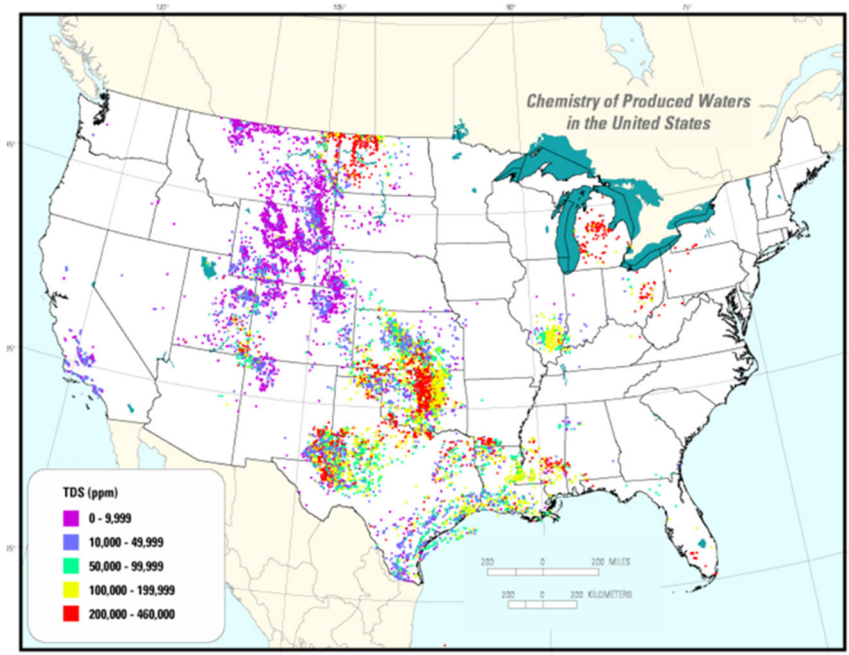

Figure xx. Chart of produced water salinity based on data from the USGS database.

<http://energy.cr.usgs.gov/prov/prodwat/tds.htm>

Focusing more closely on the Permian Basin, the chart below is a graphic from the USGS database using primarily data from before 2010. It shows the wide variation from less than 33,000 mg/L to over 300,000 mg/L.

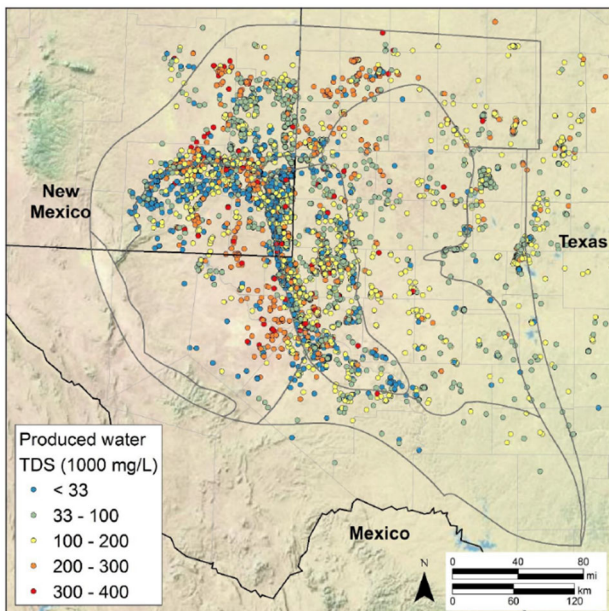

Fig. S30. Distribution of produced water total dissolved solids (TDS) obtained from the USGS produced water database (version 2.2). Original map image created in ESRI ArcGIS version 10.3.1. (Public data available at <https://energy.usgs.gov/EnvironmentalAspects/EnvironmentalAspectsOfEnergyProductionandUse/ProducedWaters.aspx>)

Figure xx. Chart of produced water salinity based on data from the USGS database.

The graphic below by Binod K Chaudhary from a presentation in 2016, and reference [9], shows the variability of TDS by depth in the Permian. This data uses the same USGS database that contains primarily old data pre-shale plays.

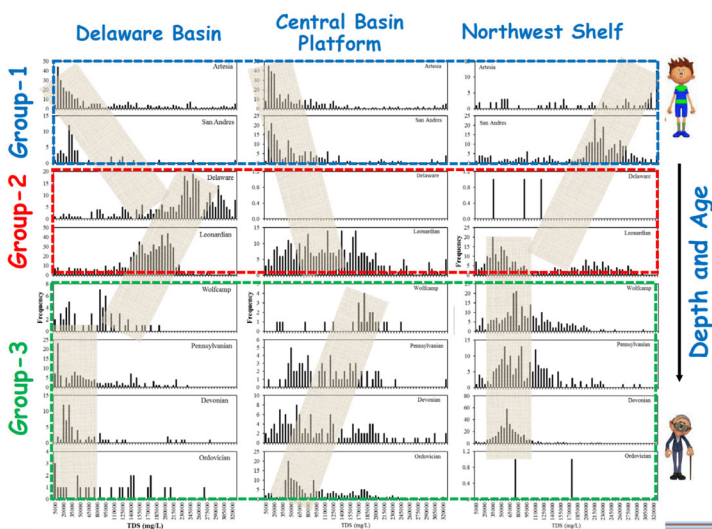

Figure xx. Histograms of TDS as a function of basin (Delaware, CBP, Midland) and as a function of depth (Group 1, 2 and 3) [9].

The same Chaudhary presentation indicates that TDS in the Wolfcamp group, Group 3 above, has higher values in the northern Delaware subbasin and lower values in the southern area (Texas).

The above data can be compared to data collected by Champion-Nalco field technicians [1]. The Champion-Nalco data were restricted to specific geological settings but were geographically widespread across the Permian. The three geological settings studied were the Wolfcamp and Bone Spring. In the table below statistical measures are given for a number of constituents. Below the table, histograms are given for the TDS of the Wolfcamp and Bone Spring laminations.

Table xx. Dissolved species analysis for produced water form the Wolfcamp and Bone Springs formations in the Delaware and Midland Basins [1].

	Chloride	Sulfate	Bicarbonate	Calcium	Magnesium	Iron	Barium	Strontium	Sodium	Manganese	TDS	Dissolved CO2	Dissolved H2S	Calculated pH
<b>Wolfcamp</b>														
Average	67,960	1,130	402	2,797	478	107	2.63	439	40,468	1.62	113,694	230.5	5.19	5.97
Min	364	102	12.2	134	103	0.00	0.03	4.46	503	0.00	2,481	10.00	0.00	4.75
Max	156,000	5,742	3,087	19,649	2,430	2,152	133	1,509	100,174	27.1	263,106	1210	427.5	7.39
Median	67,000	866	183	2,673	429	77	1.76	472	39,191	1.13	111,090	205.0	0.00	5.90
Stand Dev	15,125	858	628	1,866	297	205	10.1	229	9,962	2.76	25,428	144.3	40.37	0.41
<b>Bone Springs</b>														
Average	70,907	765	300	6,914	1,873	27.1	61.9	596	36,290	3.43	115,933	313	100	5.83
Min	11,000	36.0	12.2	80.0	42	0.00	0.00	72.8	5,903	0.00	19,194	30.0	0.00	4.38
Max	167,000	2,667	1,830	27,749	4,851	170	713	2750	106,215	12.6	277,781	600	257	6.85
Median	53,000	672	146	2,647	1,118	16.1	1.91	134	28,197	0.32	86,800	300	51.0	5.92
Stand Dev	53,498	662	372	9,125	1,497	32.7	180	873	24,036	4.69	85,441	164	88.3	0.57

### Wolfcamp TDS

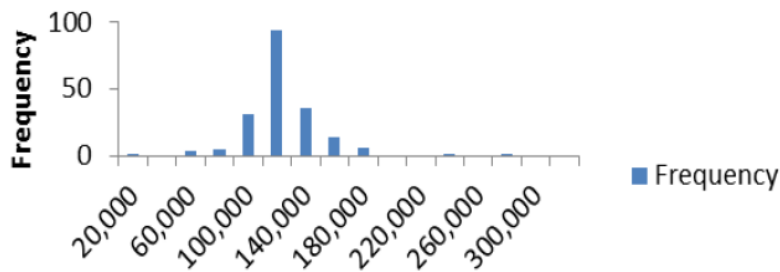

### Bone Springs TDS

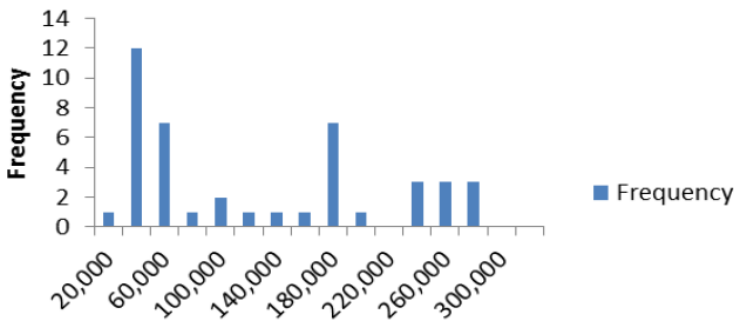
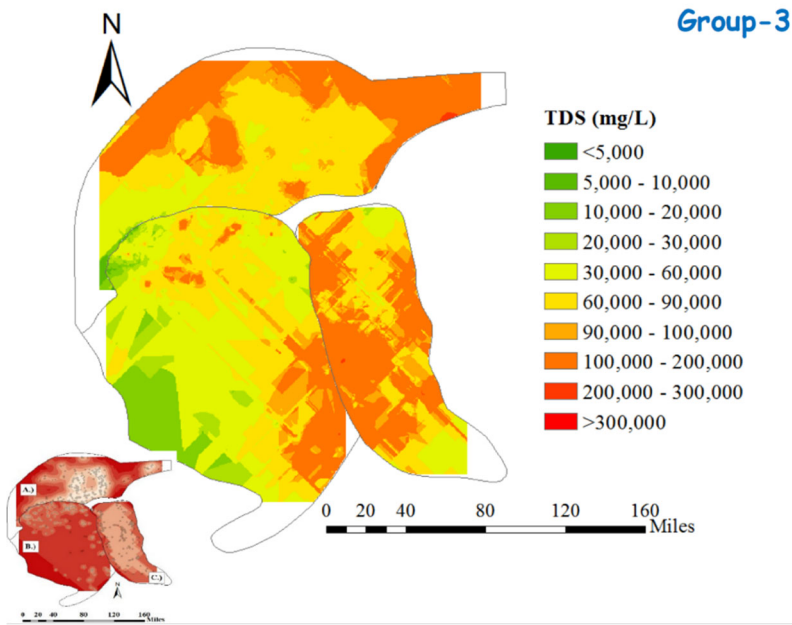
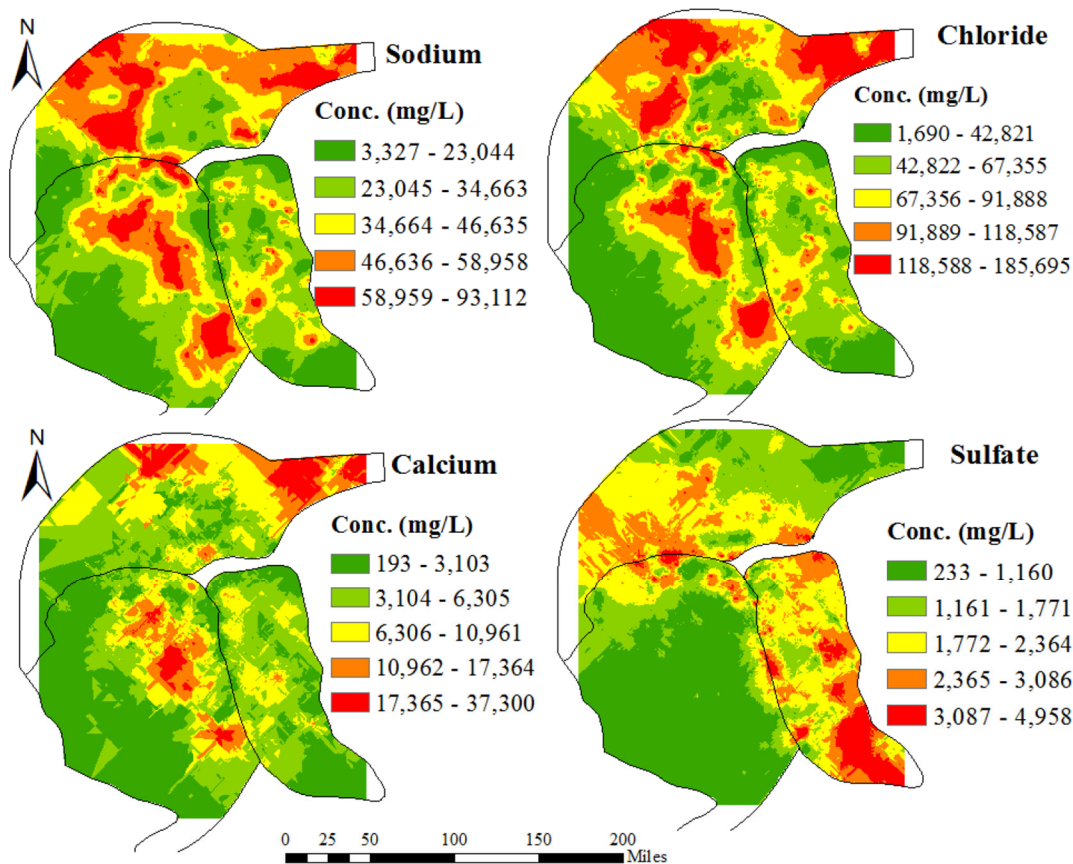

Figure xx. Histograms of TDS for produced water samples taken in the Wolfcamp and Bone Springs formations in the Delaware and Midland Basins [1].



This third graphic (below) from Chaudhary [9] indicates the areal variation of four individual parameters.



The Ground Water Protection Council report on produced water from 2019 reported produced water quality by basin. Data was collected from a group of producing companies via API. The data was from shale wells and was notably much more current than the USGS database. The shows average and high parameters for various analytes by basin. The Delaware and Midland sub-basins of Permian are highlighted in green.

	pH		TDS (mg/l)		Calcium (mg/l)		Magnesium (mg/l)		Bicarbonates (mg/l)		Sulfates (mg/l)		Chlorides (mg/l)	
	High	Average	High	Average	High	Average	High	Average	High	Average	High	Average	High	Average
Bakken	7.2	5.9	317,040	270,743	28,184	15,886	2,198	1,164	530	451	1,109	271	195,999	164,756
Central OK	7.4	6.6	162,884	70,547	12,431	3,376	1,955	776	1,076	476	1,502	530	112,348	44,839
Delaware	7.7	6.7	216,319	129,354	17,078	5,892	4,410	1,150	3,410	516	3,060	904	132,995	79,719
DJ/Niobrara	8.3	7.0	74,940	28,238	4,298	574	766	64	1,382	561	2,849	80	51,289	16,470
Eagle Ford	7.6	6.5	82,669	41,999	5,607	2,300	769	341	1,348	378	399	94	56,850	27,893
Haynesville	7.1	5.5	206,835	111,551	21,121	10,470	812	502	590	199	127	13	138,583	68,965
Marcellus	7.2	6.0	315,118	169,177	45,724	15,207	3,626	1,326	345	137	55	11	192,694	108,748
Midland	7.4	6.7	130,841	112,885	29,139	27,059	659	496	753	489	1,292	754	79,293	66,606
Utica	6.5	5.9	288,318	226,590	36,374	26,874	3,398	2,715	230	67	222	23	185,583	145,253

### 3.1 New Mexico

Hightower and co-workers [3] provided the following map of chloride content of produced water in the S.E. corner of New Mexico.

Mike Hightower, leader of the New Mexico Produced Water Research Consortium (NMPWRC), indicates that there are pockets of conventional produced water in the 25,000 to 50,000 ppm TDS. The Daggered Draw area between Carlsbad and Artesia has conventional produced water around 10,000 ppm TDS. The lower TDS water could typically be treated for lower costs than the typical 100,000+ ppm TDS produced water. If this low salinity conventional water was being used for water flooding, the higher TDS unconventional water could be substituted.

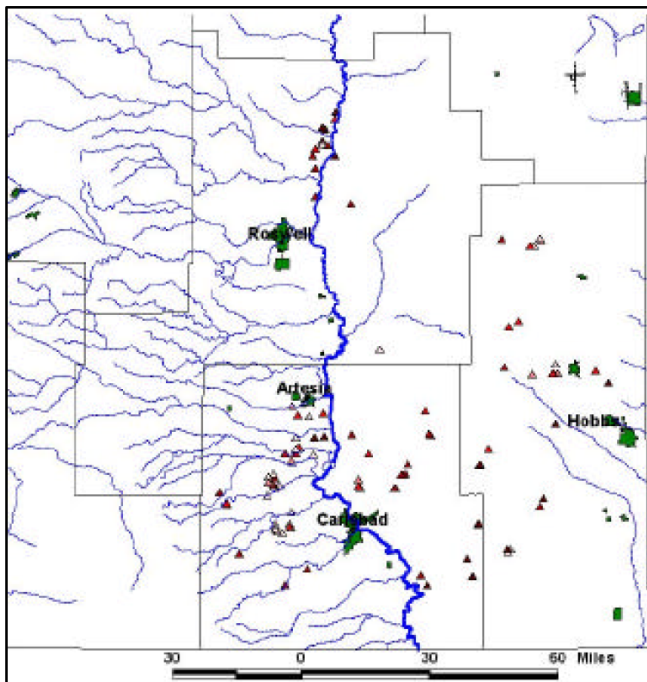

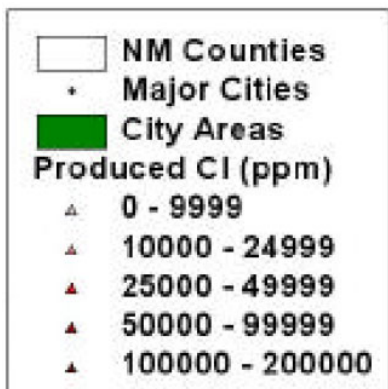

The USGS has information on “real-time” data on Pecos River temperature, conductance and discharge values as shown below.

### Real-Time Specific Conductance, in $\mu\text{S}/\text{cm}$

April 17, 2020 09:30ET

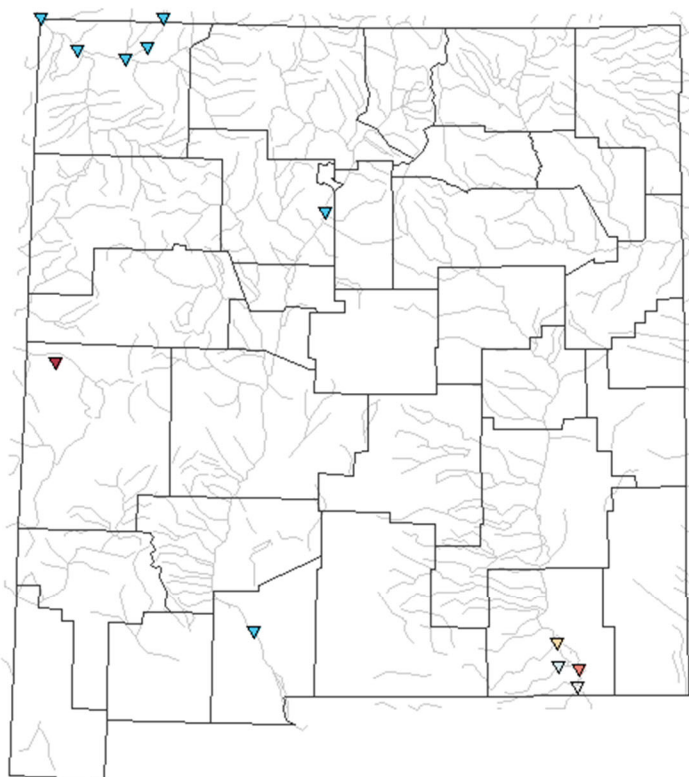

Explanation						
▼	▼	▼	▼	▼	▼	▼*
<250	250-749	750-2,240	2,250-4,990	5,000-9,990	10,000-35,000	>35,000
						No Data

Temp	Cond	pH	D.O.	Turb	Nitrate	Disch	Chlorophyll
------	------	----	------	------	---------	-------	-------------

USGS NM water

### 3.2 Texas

In 2016 Engle and coworkers [6] published a paper on the geochemistry of formation water in the Midland region of the Permian Basin. Produced water quality results were associated with their respective geological formations. As shown in the figure below, histograms of TDS are given for a number of reservoirs in the Midland region. As shown by the grey-

shaded areas there are two natural groups in the data. The top grey are slants from the upper left to the lower right. This suggests that TDS increases with depth (i.e. age of reservoir). The second grey area is essentially vertical and highlights strata of relatively low salinities. These older and deeper reservoirs may be the result of the infiltration of meteoric water or the injection of low salinity water during waterflood.

The analysis was restricted to the Midland Basin. Our immediate interest is in the Delaware Basin in New Mexico. However, the Engle paper provides the geologic strata for all of the analyses presented. This makes much of the Engle analysis applicable to the strata in New Mexico.

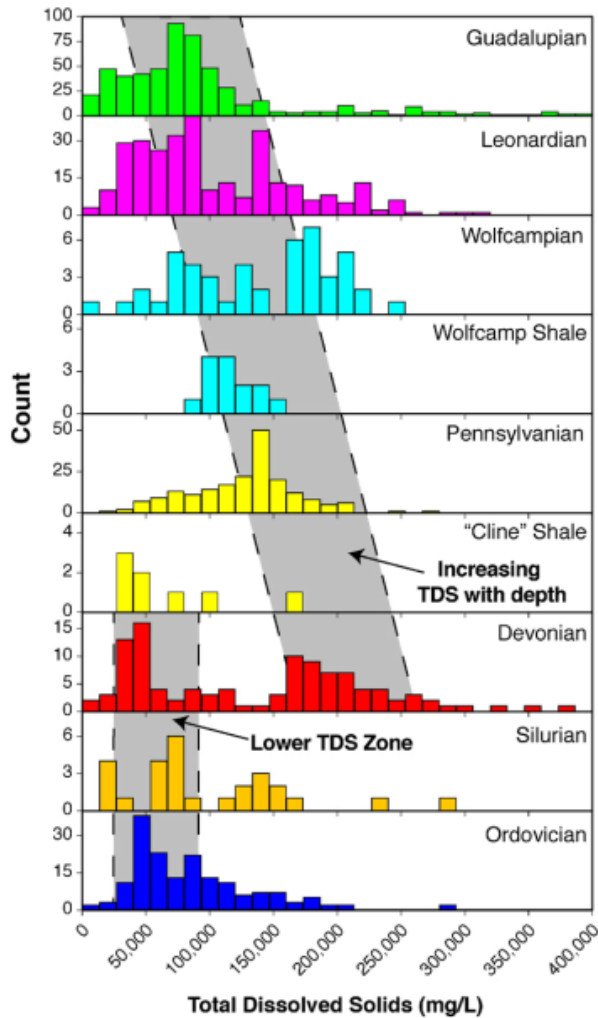

**Figure xx. Histograms of TDS (x-axis) as a function of depth (y-axis).**

A subsequent paper published in 2019 by Bryndzia et al. [8] applied a similar analysis to that of Engle to the Wolfcamp formation in the Delaware Basin. Most formations in the Delaware Basin have high water/oil ratios. Essentially two regions of the Wolfcamp were found. One region has a salinity in the range of 23 kmg/L. They found evidence that the formation water in this region came from two sources. One source was the original water associated with shale and mudstone sediment when the original sediment was buried some 50 Ma. The second source of water was from the Smectite/Illite transformation that generally occurs. This is supported by a relatively low Smectite concentration and a high Illite concentration. When this conversion occurs water, silica and iron are expelled from the Smectite clay in significant quantities. This expelled water would have low salinity and would dilute the existing Wolfcamp formation water. In this geologic model there is no evidence of dilution of the Wolfcamp formation water. It is proposed that this region of the Wolfcamp formation has water that was originally buried with the original sediment, plus water from in-situ clay conversion.

In a second region of the Wolfcamp formation they found much higher salinity (50 to 125 mg/L). It is proposed that this formation water came in contact with a high salinity seawater evaporite brine that flowed into the Wolfcamp formation. The driving force for the flow of the high salinity brine was an uplifting of the western edge of the Delaware Basin. A osmotic pressure mechanism is proposed to account for high WOR in this portion of the Wolfcamp formation.

## 4.0 Water Quality Required for Beneficial Reuse

### 4.1 Agriculture

This section discusses the water quality required for beneficial reuse of produced water for non-food crop irrigation. Government specifications, where they exist are discussed. Also, the toxicity of produced water is discussed. In general, produced water has several classes of compounds that are toxic to varying degrees. These toxic components include:

- volatile aromatic hydrocarbons,
- polycyclic aromatic hydrocarbons (PHA),
- certain organic acids,
- phenols,
- metals,
- radionuclides,
- and salt concentrations above a certain threshold.

The US Federal Government has not thus far promulgated rules or regulations for the reuse of produced water in agricultural applications. The US EPA mostly delegates this authority to the individual states. The Federal Government does however provide a set of guidelines [56]. These guidelines provide useful information regarding state rules and regarding the different state agencies that are involved in permitting produced water for agricultural use.

The United Nations Food and Agriculture Organization (FAO), Rome, provides extensive information and guidelines on irrigation water quality for agriculture [52]. The guidelines do not cover the subject of produced water or reuse. Nevertheless, the guidelines on irrigation water quality are useful for assessing the likelihood of a successful produced water reuse application. Information from these guidelines is given below.

Irrigation of crops using produced water carries a risk of impairing soil function and of killing various soil microorganisms that are important in germination and growth of plants. Besides this toxic effect the salinity of produced water and the ratio of sodium to calcium plus magnesium has a direct and detrimental impact of soil properties. Direct effects of irrigation water on sensitive crops may also occur. Non-food crops are often preferred for irrigation reuse in order to avoid direct ingestion pathways.

The following studies exposed various crop samples to untreated and treated produced waters with a wide variety of results related to product quality and yield, though most indicate at least short-term use with either processed produced water or untreated CBM produced water is acceptable in terms of plant performance, and soil/water ionic interactions.

Ferreira et al. [48, 50] evaluated the effect of using produced water on soil microorganisms in fields of biofuel crops of castor beans and sunflowers. The study was conducted using three different sources of irrigation water:

- ground water
- filtered produced water
- produced water treated with filtration followed by reverse osmosis

No details are given regarding the type of filtration used. Soil quality was analyzed in terms of the species composition, richness and abundance of soil microbes (mesofauna). The ranking of soil quality after a period of cultivation was: groundwater > filtered water > RO water. It was found that the ground water had the highest quality of soil, as expected. Produced water that had undergone RO treatment had a measurably negative impact on the soil quality. A possible



explanation for this effect could have been to required use of biocide (glutaraldehyde) and anti-scalant in order to prevent fouling of the RO membrane.

Sousa et al. [49] evaluated the effect of using groundwater, filtered produced water, and filtered/RO produced water on the seed and plant biomass production of sunflowers. They also measured the accumulation of mineral and metals in the plants. They found that the filtered water had the greatest accumulation of these materials as well as having the lowest biomass and seed production. They concluded that use of RO treated produced water is viable although they also recommended more research into long-term accumulation of minerals and metals in the plants.

Souza et al. 2017 [43] studied the effect of produced water treated by electrocoagulation/reverse osmosis (EC-RO) on the germination and early growth of sunflower crops. EC-RO was found to be very efficient at removing dispersed and dissolved components of the produced water. Treated produced water had no adverse effect on sunflower growth.

Da Costa et al. [40] studied the effect of untreated produced water versus treated produced water on the germination and growth of sunflower seedlings. Electroflocculation (EF) was the only treatment used for the treated produced water. Also, there was no comparison made to produced water versus ground water. Often in studies on the effect of produced water a control or baseline treatment using ground water will be carried out. The measured characteristics of the treated and untreated produced water are given in the table below. One of the findings of the study is that EF was effective at removing suspended contaminants such as oil and grease and turbidity. EF was also effective at reducing color and COD which are composed of a combination of dissolved and suspended contaminants. Comparing the treated and untreated produced water did not reveal any differences in seed germination percentage, speed of germination, germination index, biomass production.

Sunflower was selected because it is an important crop for farmers since it is a short-cycle plant with great adaptability to different soil and climate conditions. It is economically important as a food for cattle, humans, as a source of oil, and as a feedstock for the manufacture of biodiesel. It tolerates relatively high salinity and metal content. The study was carried out in Brazil and was funded by a grant from the Rio de Janeiro State Research Foundation (FAPERJ). Thus, the economic and regulatory drivers would not be entirely applicable to the US.

Niemeyer et al. [41] carried out tests with sunflowers using a laboratory scale produced water treatment system consisting of gravity separation, sand filter, activated carbon filter, and reverse osmosis. Treated and untreated produced water and water from the public water supply were tested. Leachate was tested for toxicity. One of the main findings was the verification that the main impact of produced water on soil quality is due to its salinity. This has been observed in other studies. Niemeyer et al. studied two important soil parameters, habitat function and retention function. Habitat function is a test that measures the ability of a soil sample to serve as a habitat for plants, microorganisms, and soil-living animals. It is considered to be the most important parameter in assessing the health of an agricultural soil. The retention function measures the tendency of a soil to retain contaminants. Other parameters measured include the response of earthworms and insects as well as the aquatic toxicity and leachate retention. Five different treatments were applied to the produced water as given in the table below. For all of the water treatments listed significant deterioration of the soil quality was observed except for the public water and the RO-treated water.

**Table 1**  
Produced water (PW) treatments and control description and abbreviation.

Abbreviation	Treatment
WOS	water-oil separation
SF	WOS + sand filter
AC	WOS + SF + activated charcoal
RO	reverse osmosis
MR	mixture reason (WOS + RO)
WS	public water supply (control)

Yan et al. [51] provide a review of the effects of salinity and water content on soil microorganisms. Soil microorganisms are important in supporting crops since they provide the initial digestion of raw organic materials into nutrients that can be taken up by plants. As the authors point out, salinity increases osmotic pressure which reduces uptake of water into the soil microbes and into the plant. It also delaminates certain clay materials which reduced the permeability of the soil.

As discussed by Ayers and Westcot [52], the two most common water quality factors which influence the normal infiltration rate are the salinity of the water (total quantity of salts in the water) and its sodium content relative to the calcium and magnesium content (SAR). The TDS guideline is given in the table below where it is seen that a TDS of 2000 mg/L is considered to be severely high. A high salinity water will increase infiltration. A low salinity water or a water with a high sodium to calcium/magnesium ratio will decrease infiltration. Acceptable SAR values vary depending on the TDS as shown in the table. Both salinity and SAR may impact the soil at the same time. Secondary problems may also develop if irrigation must be prolonged for an extended period of time to achieve adequate infiltration. These include crusting of seedbeds, excessive weeds, nutritional disorders and drowning of the crop, rotting of seeds and poor crop stands in low-lying wet spots. One serious side effect of an infiltration problem is the potential to develop disease and vector (mosquito) problems. When a soil is irrigated with a high sodium water, a high sodium surface soil develops which weakens soil structure. The surface soil aggregates then disperse to much smaller particles which clog soil pores. The problem may also be caused by an extremely low calcium content of the surface soil. In some cases, water low in salt can cause a similar problem but this is related to the corrosive nature of the low salt water and not to the sodium content of the water or soil. In the case of the low salt water, the water dissolves and leaches most of the soluble minerals, including calcium, from the surface soil.

Toxicity problems occur if certain constituents (ions) in the soil or water are taken up by the plant and accumulate to concentrations high enough to cause crop damage or reduced yields. The degree of damage depends on the uptake and the crop sensitivity. The permanent, perennial-type crops (tree crops) are the more sensitive. Damage often occurs at relatively low ion concentrations for sensitive crops. It is usually first evidenced by marginal leaf burn and interveinal chlorosis. If the accumulation is great enough, reduced yields result. The more tolerant annual crops are not sensitive at low concentrations but almost all crops will be damaged or killed if concentrations are sufficiently high.

The ions of primary concern are chloride, sodium and boron. Although toxicity problems may occur even when these ions are in low concentrations, toxicity often accompanies and complicates a salinity or water infiltration problem. Damage results when the potentially toxic ions are absorbed in significant amounts with the water taken up by the roots. The absorbed ions are transported to the leaves where they accumulate during transpiration. The ions accumulate to the greatest extent in the areas where the water loss is greatest, usually the leaf tips and leaf edges. Accumulation to toxic concentrations takes time and visual damage is often slow to be noticed. The degree of damage depends upon the duration of exposure, concentration by the toxic ion, crop sensitivity, and the volume of water transpired by the crop. In a hot climate or hot part of the year, accumulation is more rapid than if the same crop were grown in a cooler climate or cooler season when it might show little or no damage. Guidelines for evaluation of water quality for irrigation are given in Table 1. They emphasize the long-term influence of water quality on crop production, soil conditions and farm management.

**Table 1** GUIDELINES FOR INTERPRETATIONS OF WATER QUALITY FOR IRRIGATION<sup>1</sup>

Potential Irrigation Problem	Units	Degree of Restriction on Use		
		None	Slight to Moderate	Severe
<b>Salinity</b> (affects crop water availability) <sup>2</sup>				
EC <sub>w</sub>	dS/m	< 0.7	0.7 – 3.0	> 3.0
(or)				
TDS	mg/l	< 450	450 – 2000	> 2000
<b>Infiltration</b> (affects infiltration rate of water into the soil. Evaluate using EC <sub>w</sub> and SAR together) <sup>3</sup>				
SAR = 0 – 3	and EC <sub>w</sub> =	> 0.7	0.7 – 0.2	< 0.2
= 3 – 6	=	> 1.2	1.2 – 0.3	< 0.3
= 6 – 12	=	> 1.9	1.9 – 0.5	< 0.5
= 12 – 20	=	> 2.9	2.9 – 1.3	< 1.3
= 20 – 40	=	> 5.0	5.0 – 2.9	< 2.9
<b>Specific Ion Toxicity</b> (affects sensitive crops)				
<b>Sodium (Na)<sup>4</sup></b>				
surface irrigation	SAR	< 3	3 – 9	> 9
sprinkler irrigation	me/l	< 3	> 3	
<b>Chloride (Cl)<sup>4</sup></b>				
surface irrigation	me/l	< 4	4 – 10	> 10
sprinkler irrigation	me/l	< 3	> 3	
<b>Boron (B)<sup>5</sup></b>				
	mg/l	< 0.7	0.7 – 3.0	> 3.0
Trace Elements (see Table 21)				
<b>Miscellaneous Effects</b> (affects susceptible crops)				
<b>Nitrogen (NO<sub>3</sub> - N)<sup>6</sup></b>				
	mg/l	< 5	5 – 30	> 30
<b>Bicarbonate (HCO<sub>3</sub>)</b>				
(overhead sprinkling only)	me/l	< 1.5	1.5 – 8.5	> 8.5
pH				
		Normal Range 6.5 – 8.4		

Burgos and Lebas [53] observed a sustainable growth rate and quality when using produced water for irrigation of reed canary grass and sorghum with TDS levels up to 2,500 mg/L together with organics. At higher TDS levels up to 7,000 mg/L there was no observed mortality for sorghum NS.

Pica et al. [47] found that non-food biofuel crops of rapeseed and switchgrass were capable of productive growth when irrigated with produced water from the CBM development of the Powder River Basin at TDS levels of 3,500 mg/L.

Andrade et al. [54] studied the ecotoxicological effects of produced water that had been desalinated using mechanical Vapor Recompression (MVR). Algae, fish, lettuce, and earthworms were used in the toxicity testing. The MVR effluent was found to be non-toxic to all species except the algae which experienced chronic toxicity due to the presence of ammonia in the MVR effluent. Once the ammonia was stripped, the algae experienced no toxicological effects.

Lewis et al. [55] blended 4 parts of ground water with 1 part of treated produced water and applied the mixture to a cotton crop. The produced water treatment was provided by Energy Water Solutions (Woodlands, TX). The treated produced water had lower chloride than the ground water and contained lower concentrations of key contaminants. Both water sources gave similar cotton crop yield. The cotton yield was 568 lbs/acre for the treated produced water, and 587 lbs/acre for the groundwater. Soil salinity reduced with the use of the PW/GW blended water.

Burkhardt et al. [45, 46] determined that untreated produced water could be used to irrigate crops for roughly two years before detrimental effects were observed on the plants and soil. Blending of the produced water with high quality irrigation water extended this time period to beyond two years.

De Meneses et al. [44] studied the effect of using produced water for irrigation of oilseed (castor bean and sunflower) crops. They evaluated the effect of treated produced water on the biological properties of the soil. Three water types

were used, ground water, filtered produced water, and filtered/RO treated water. The soil properties (microbiological activity and organic carbon) in the sunflower crop deteriorated with the used of both types of produced water. The deterioration in the castor bean crops was less pronounced.

Burkhardt et al. [45, 46] studied switchgrass and wormwood crops irrigated with coal bed methane produced water. Various blends of produced water with fresh water were evaluated. The blends had higher SAR values than the fresh water control. Biofuel yields decreased with increasing percentage of produced water.

## 4.2 Mining

The Delaware Basin is a major source of potassium salts. The general terminology for these salts is potash which refers to any of several water soluble potassium salts. The specific minerals found in the Delaware are sylvite (potassium chloride) and langbeinite (potassium magnesium sulfate). Layered deposits are found throughout the region in the Salado formation. The potash mining industry started in 1931. Halite (sodium chloride, rock salt, table salt) are a by-product of potash mining.

The mines use fresh water to wash the minerals. The water picks up salts in the rock and becomes saline. After washing, the saline water is often stored in large unlined evaporation ponds under permits dating back to the early days of the mines.

### **Jal Potash Plant Planned**

PolyNatura officials are planning for a \$330 million polyhalite mine to be built and operational 27 miles west of Jal by around 2022. [Potash plant coming soon near Jal NM](#)

### **Intrepid mine east of Carlsbad**

A mine in New Mexico says it needs to use 3.2 billion gallons of drinking water for the next two years, possibly robbing 64,000 people of access to clean water. The Hobbs News-Sun reports that Lea County commissioners voted last week to send a letter to the federal government to protest the potential use of water to flood the fertilizer mines. Commissioners want the U.S. Bureau of Land Management to include Lea County in its environmental review of a proposal spearheaded by Intrepid Potash to extract potash ore from an underground mine by flooding it with water out of Lea County. The project would be an extension to Intrepid's already existing solar solution mine that's located about 20 miles east of Carlsbad. The commission's letter comes as the BLM continues to seek public comment about the project extension. [Intrepid Potash](#) [Intrepid 2015 water plan](#)

Intrepid Potash, which has mining and processing operations near Carlsbad, announced in May it had finalized leasing agreements with several oil and gas operations for a portion of their water rights. The water will likely be used for hydraulic fracturing, or "fracking," jobs. "Intrepid is one of the largest water rights owners in southeast New Mexico and we have begun to monetize those rights," said Intrepid president and CEO Robert Jornayvaz during a May 2 conference call on first quarter earnings. "During the first quarter, we finalized multiple contracts with various oil companies and water delivery companies to lease a portion of our significant rights, and are currently negotiating additional agreements but most importantly are delivering water and collecting revenue." [Intrepid selling water for frac'ing](#)  
[Intrepid & NGL Water deal](#)

### [Intrepid selling water 2019](#)

In April, 2020, a NM state district judge ruled that the New Mexico Office of the State Engineer needed to show cause for issuing the company seven "preliminary authorizations" to shift its water rights from use for potash refining to sales to the oil and gas industry, the Carlsbad Current-Argus reports.

# Ochoa Project Overview

Timeline: updated from Feasibility Study

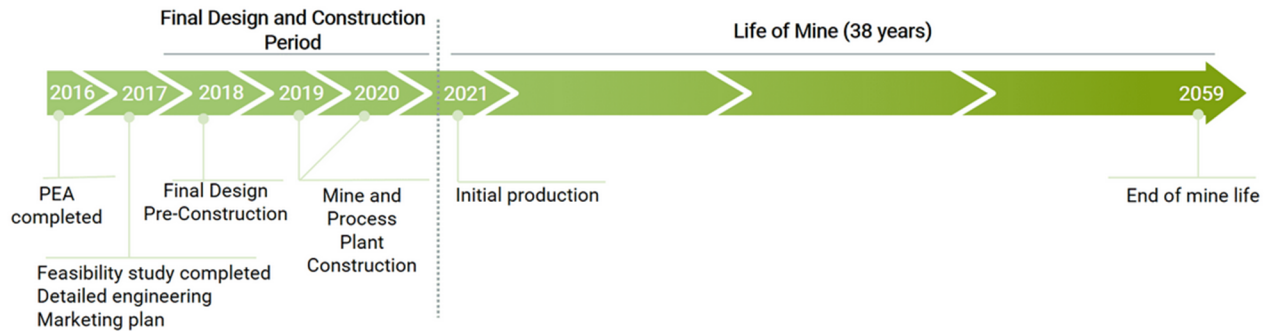

## Facts at a Glance

**Located in Lea County, New Mexico, USA:** an excellent mining jurisdiction with ready access to infrastructure, ports, utilities, and skilled labor

**Well-positioned to become the only polyhalite producer in North America:** first production expected in 2021, ramping up to 2 million tons per year in 2023

**Ideally situated:** ready access to U.S. clients or for export to Latin America and Asia

**38-year mine life:** 71 million tons Proven & Probable Reserves (88% polyhalite grade)

**Preliminary designs of mine and processing plant:** complete to Class 3 level accuracy and relatively low capital intensity (anticipated development capital budget of \$328 million)

**Project NPV of \$1,034 million, unlevered IRR of 26%, and payback period of 2.8 years:** based on 8% cost of capital and \$193 per ton life of mine average product price

**Numerous off-take agreements underway:** letters of intent in place or in negotiation for a majority of our planned annual production

### Headquarters

600 West Bender Blvd.  
Hobbs, New Mexico 88240  
USA

© 2017 PolyNatura Corp.

## Ochoa plant

Mosaic has a potash plant in Carlsbad, NM [Mosaic in Carlsbad](#). In a conversation with Mosaic's Scotty Diddle, they indicated to Michael Dunkel that they had a ground water source of 18,000 ac-ft and that they have plenty of water. The Mosaic plant mines a specialized micronutrient. The mine/plant is expected to have a 50-year life.

A summary of mining in Lea and Eddy Counties in New Mexico shows that they have their current water needs met by ground water sourcing. It is possible that in the future the mines will need additional water or may have pressure to preserve the aquifers. In these scenarios, mining could be a potential user of desalinated produced water.

## 4.3 Rangeland

According to Mike Hightower, leader of the New Mexico Produced Water Research Consortium (NMPWRC), rangelands offer a good option for desalinated produced water. About one third of New Mexico is rangelands that are often federal lands, including the Bureau of Land Management (BLM). Many rangeland areas need two to four inches of additional water per year to allow gas and hay to thrive, usually applied in the spring and fall. The additional hay and grass sequester carbon, reducing greenhouse gas. The additional water and hay also support additional head of cattle per section (320 acres). Since the rangelands are widely dispersed, this application would work more effectively with a series of distributed water treatment plants that could keep the transportation costs of the lower than a centralized plant.

## 4.4 Others (Power plants, Refining, Pecos River relief for NM, Frac sand washing)

### **Power Plants in southern New Mexico**

Natural gas [\[ edit \]](#)

[10]

Name	Location	Capacity (MW)	Operator	Year opened
Cunningham	Lea County	519	Southwestern Public Service Co	1957/1965/1998
Hobbs	Lea County	665	Lea Power Partners	2008
LCEC Generation	Lea County	46.5	Western Farmers Elec Coop, Inc	2012
Maddox	Lea County	212	Southwestern Public Service Co	1963/1967/1976

### Power plants in NM

Water withdrawal and consumption factors vary greatly across and within fuel technologies. Water factors show greater agreement when organized according to cooling technologies as opposed to fuel technologies. Once-through cooling technologies withdraw 10 to 100 times more water per unit of electric generation than recirculating cooling technologies; recirculating cooling technologies consume at least twice as much water as once-through cooling technologies. Natural gas plants may consume 100 to 400 gallons per MWh of power, depending on the system. Therefore, a 519 MW plant like Cunningham could consume 454 million to 1.8 billion gallons of water per year, or 30 kBWPD to 119 kBWPD.

According to the New Mexico State Engineer 2015 Water use report, the plants in Lea County reported 4,472 acre-feet of water use in 2015. This is 34.7 million barrels per year, or 95 kBWPD, for the four plants. If the water use is allocated according to plant MW capacity, the Hobbs plant would have used 44 kBWPD and the Cunningham plant 34 kBWPD. This potential group of water users are relatively small compared to Lea County total produced water estimate of 694 million barrels in 2019, of which 321 million barrels was from unconventional wells(Data source is Bridget Scanlon from UTBEG).

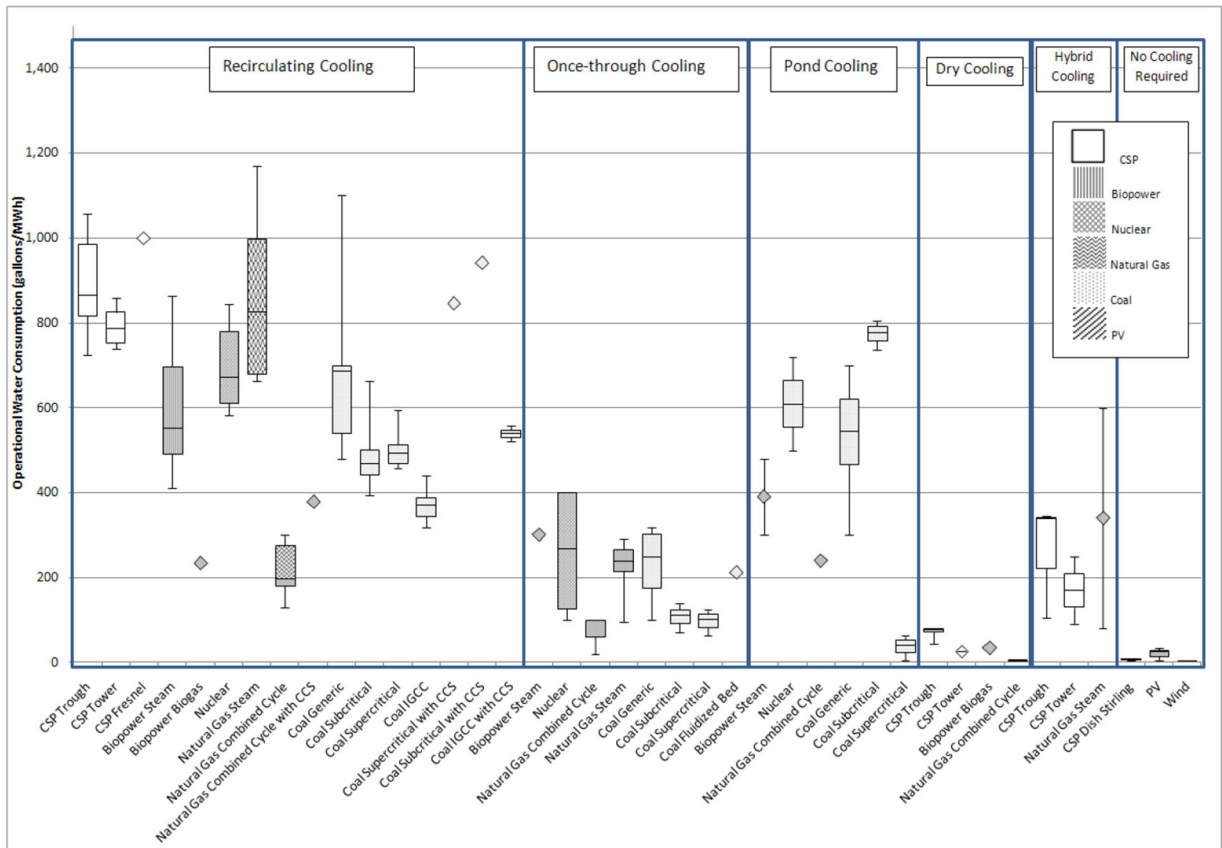

**Figure 1. Operational water consumption factors for electricity generating technologies**

IGCC: Integrated gasification combined cycle. CCS: Carbon capture and sequestration. CSP: Concentrating solar power. Whisker ends represent maxima and minima. Upper and lower ends of boxes represent 75<sup>th</sup> and 25<sup>th</sup> percentile, respectively. Horizontal lines in boxes represent medians.

[NREL study](#)

Water use across the Permian basin of west Texas and southeastern New Mexico is primarily for irrigation as shown on the USGS graphic below <https://owi.usgs.gov/vizlab/water-use-15/#view=USA&category=industrial>

According to Mike Hightower, leader of the NMPWRC, most power plants in New Mexico use evaporation ponds for their concentrated cooling water and have zero liquid discharge.

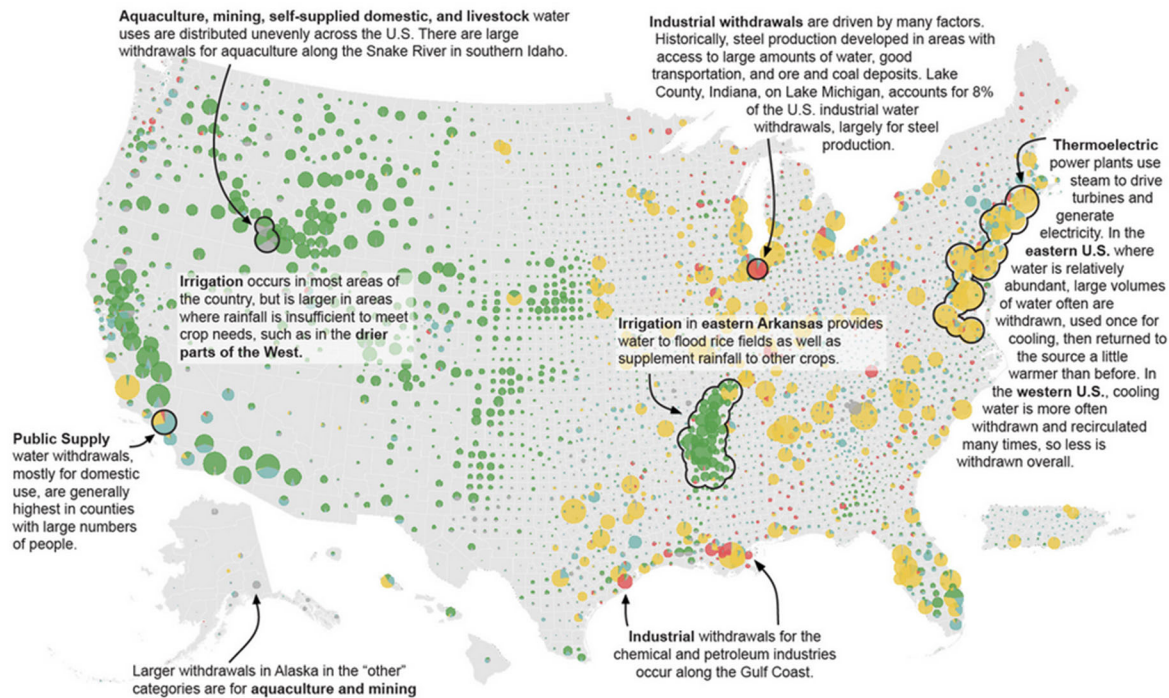

**The Sodium Adsorption Ratio:**

The following table provides data on a number of End Use Criteria compiled by ALL Consultants [2]. Also shown in the table are produced water quality data for Coal Bed Methane and conventional hydrocarbon producing well water. Most Coal Bed Methane produced water is used for irrigation but there are exceptions. When the CBM produced water contains high salinity or a high value of Sodium Adsorption Ratio (SAR) the water must be treated before it can be used for irrigation. The End Use Criteria data in the table are taken from field measurements. The data are not location-specific. However, most of the water samples were taken in the Powder River Basin, WY.

One of the important criteria for agricultural reuse is the ratio of sodium ions to calcium plus magnesium ions. This ratio is known as the SAR. A high concentration of sodium ions damages the soil. Sodium exchanges with (takes the place of) calcium and magnesium in the soil clays. When this happens, the clay delaminates (breaks up) forming small particles which clog the pores in the soil. These small particles plug the pores and prevent the flow of water and air into the soil. The soil becomes hard and impermeable. The same mechanism occurs in the hydrocarbon bearing formation when so-called swellable clays are present. When this happens the flow of hydrocarbons is reduced.

In order to estimate whether or not a given water source will cause soil damage, an empirical parameter has been devised, known as SAR.

**Specific Irrigation User – Carlsbad Irrigation District (CID)**

The Carlsbad Irrigation District (CID) is a quasi-municipality and non-profit organization that uses water from the Pecos River to distribute for agriculture, according to April Travelstead at CID. The web site lists an allocation of 3.697 acre-ft without an explanation. The allocation is multiplied by a surface owner's land, or water rights, to give the annual maximum for the water right owner. For example, a 10-acre plat would be allocated up to 37 acre-feet per year, or 287 kBW. The total acreage in CID is 25,055 acres with a potential allocation of 194 million barrels of water per year or 532,500 barrels per day for 365 days. However, the water is distributed from March 1 to October 31 annually. It can only be used for agriculture and can't be sold. Ms. Travelstead indicated that the irrigated crops include wheat, cotton, pecans and alfalfa.



Brantley dam replaced the McMillan dam and reservoir. The US Bureau of Reclamation (BOR) built the dam that is operated by CID. BOR and CID remain in a partnership. CID has priority water rights from the Pecos River. They work together with the Interstate Stream Commission to determine how much water is conserved in the river and delivered to Texas for the New Mexico and Texas Water compact. Hannah Risely-White, Pecos River Basin Manager, (505) 827-4029 was identified as a good contact at the Interstate Stream Commission. CID also operates the Avalon dam and reservoir and a system to distribute water.

Ms. Travelstead confirmed that the state of New Mexico bought ground water rights to deliver water into the Pecos for the compact with Texas. She also confirmed that CID is in an ongoing litigation with Intrepid Potash. CID is challenging Intrepid's Black River water rights. The Black River feeds the Pecos.

The Carlsbad Irrigation District (CID) has a classified section where individuals post requests to buy and sell water and water rights. <http://cidistrict.com/>

The Carlsbad Irrigation District operates the Avalon Reservoir three miles north of Carlsbad.

## Avalon Reservoir

**i** Avalon Reservoir does not offer reservations through Recreation.gov.

Please take a look at the area details below for more information about visiting this location. Enjoy your visit!

### Overview

[Avalon Dam](#) and Reservoir, Carlsbad Project, are located on the Pecos River 3 miles north of Carlsbad, New Mexico. The dam is a zoned earthfill structure constructed in 1907. Recreation at Avalon Reservoir is managed by the Carlsbad Irrigation District under agreement with the Bureau of Reclamation. New Mexico Department of Game and Fish stocks reservoir and provides law enforcement. The recreation area is open year around. This is a non-fee area with primitive facilities. There are surface roads to recreation area and unpaved roads around reservoir. There is year-round fishing for white bass, catfish, and bream. Scuba diving for game fish is permitted. Boating must conform to New Mexico regulations. Boating fees charged. Carlsbad Irrigation District Phone: (575) 885-3203 New Mexico Dept. of Game and Fish Phone: (575) 234-2829

<https://www.recreation.gov/camping/gateways/87>

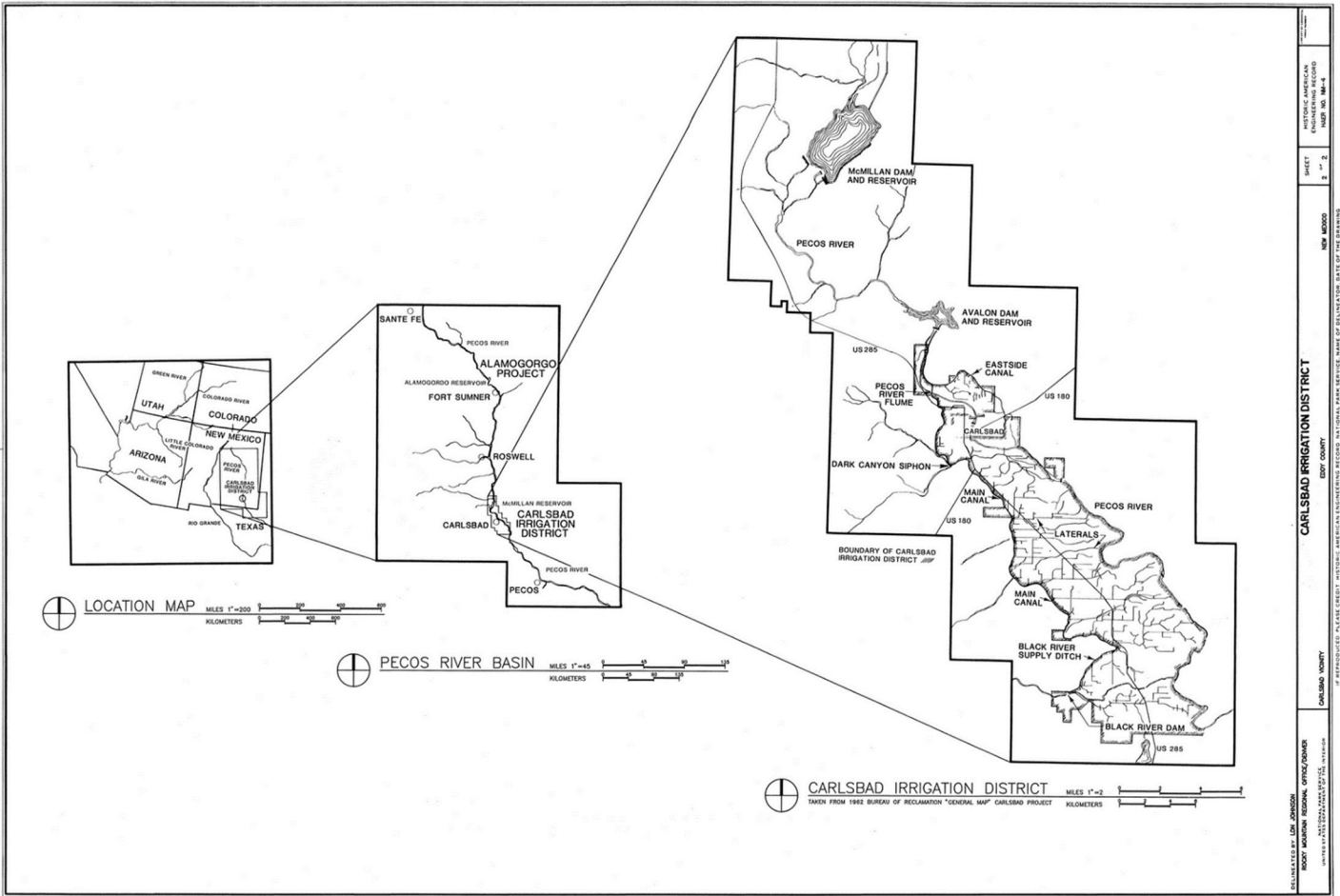

[Carlsbad Irrigation map](#) This seems to be an old map since it shows Mcmillan dam that was replaced by Brantley dam.

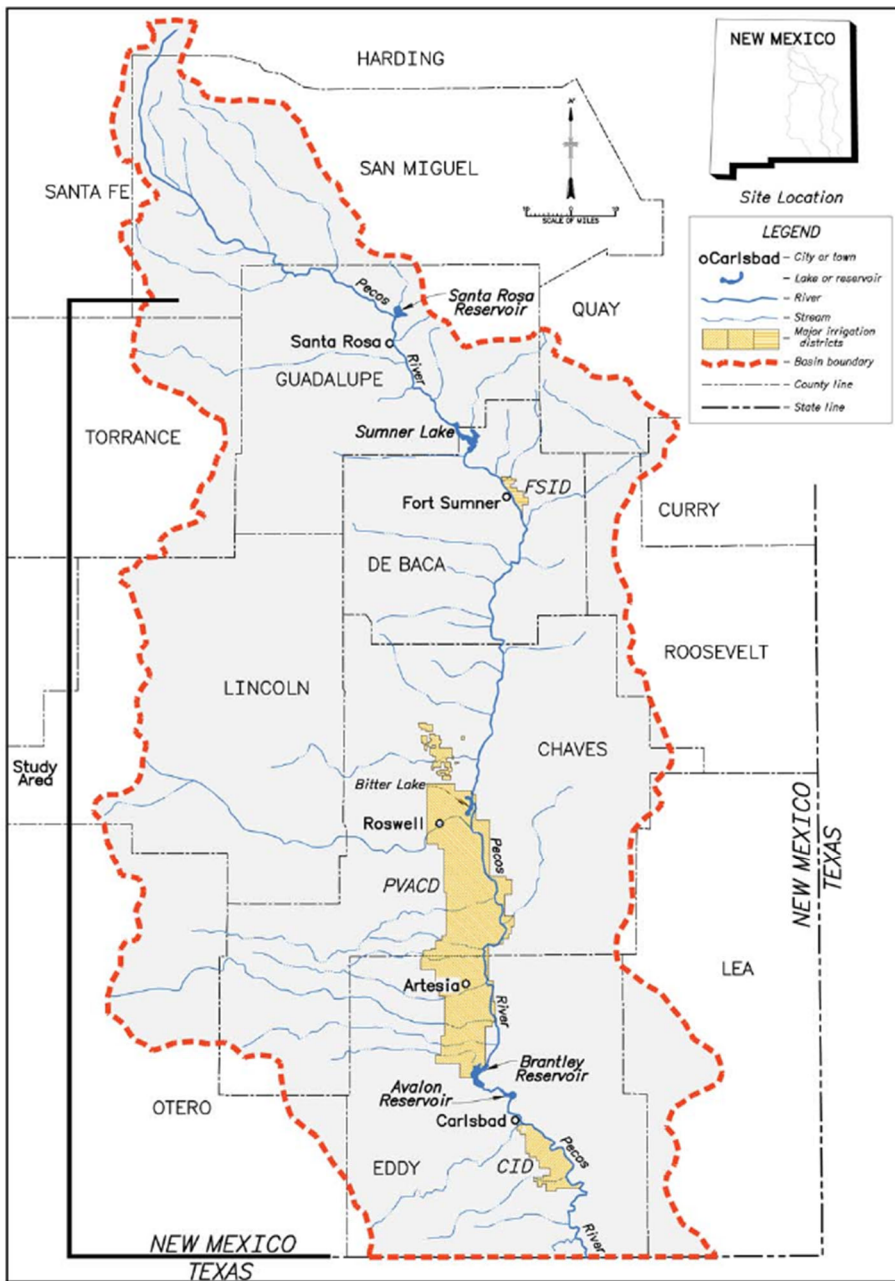

[Pecos River Basin showing Carlsbad Irrigation District](#)

Mike Hightower, head of the NMPWRC, indicated that discussions with the State Engineer have been positive about using desalinated produced water for irrigation. Some of the crops like alfalfa and cotton are not consumed by humans. Crops consumed, such as pecans, would need to show that there is no biological accumulation.

**Pecos River Compact**

The Pecos River water sharing agreement is summarized in this book available online. [Chapter 2 water rights.](#) According to the latest report on the Office of the State Engineer from August 2018, New Mexico has had overage delivers to Texas in 4 or the last 5 years and 8 of the last 10 years. New Mexico has an accumulated overage of 170,800 ac-ft since 1987, when the balance calculation started. [Pecos compact report 2018](#)  
 The State Engineer’s office supports the idea of using desalinated produced water in the Pecos River to help with the water balance. Ideally, the water would be input below Red Bluff, NM and Malaga Bend where the river contacts the

Capitan reef and picks up salinity. This location is near the city of Malaga, NM and only about 10 miles north of the Texas border.

On 4/20, Michael Dunkel Emailed and left a voice message for Hannah Riseley-White to ask about the Pecos River Compact and potential to source water from desalinated produced water.

**Table 1. Typical Values for Produced Water Quality Compared to Some Criteria**

Parameter	End Use Criteria (ppm)			CBM Water	Non-CBM (Conventional Gas Well) Water
	Drinking	Irrigation	Livestock		
pH	6.5 - 8	-	6.5 - 8	7 - 8	6.5 - 8
TDS, mg/l	500	2,000	5,000	4,000 - 20,000*	20,000 - 100,000
Benzene, ppb	5	5	5	< 100	1,000 - 4,000
SAR**	1.5-5	6	5-8	Highly Varied	Highly Varied
Na <sup>+</sup> , mg/l	200	See SAR	2,000	500 - 2000	6,000 - 35,000
Barium, mg/l				0.01 - 0.1	0.1 - 40
Cl <sup>-</sup> , mg/l	250	-	1,500	1,000 - 2,000	13,000 - 65,000
HCO <sub>3</sub> <sup>-</sup> mg/l	-	-	-	150 - 2,000	2,000 - 10,000

\* Total Dissolved Solids (TDS) range estimated for the lower 50 percentile

\*\* SAR = Sodium Absorption Ratio -- a function of a ratio of Na to Ca and Mg Levels.

In the table below, the Australian Water Quality Guidelines are given [2].

Tolerance	SAR of irrigation water	Crop
Very sensitive	2-8	Fruits, nuts, citrus, avocad
Sensitive	8-18	Beans
Moderately tolerant	18-46	Clover, oats, rice
Tolerant	46-102	Wheat, barley, tomatoes, beets, tall wheat grass, crested grass

Source: Extracted from the Australian Water Quality Guidelines for Fresh & Marine Waters (ANZECC)

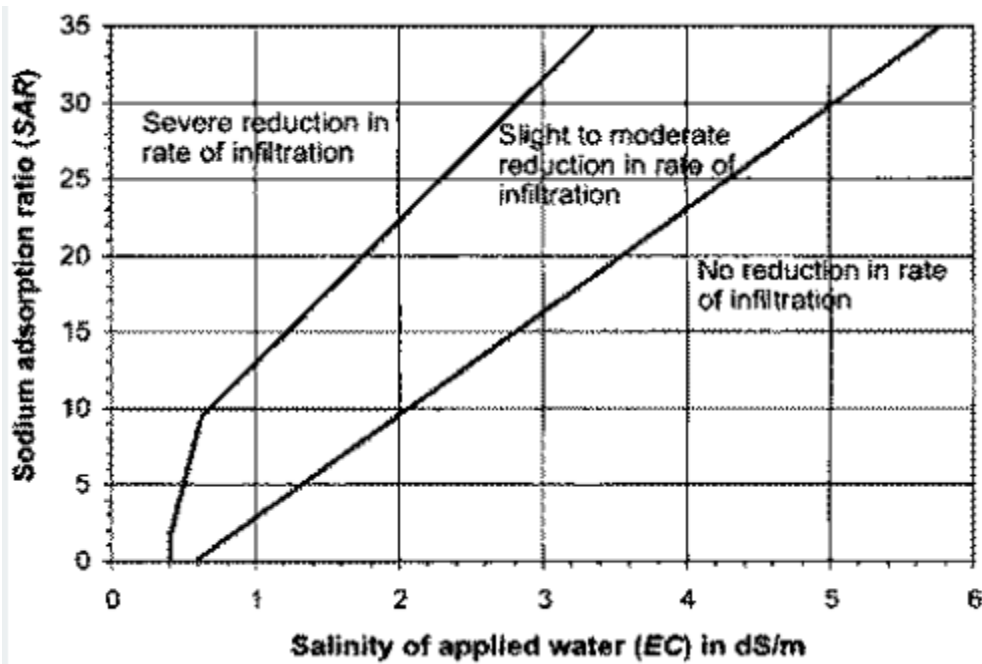

**Livestock.** A limited number of studies considered livestock watering as a potential beneficial use of produced water (Horner et al. 2011) or coalbed natural gas produced waters (Jackson and Reddy, 2007a; Zhang and Qin, 2018), with only Horner et al. (2011) specifically conducting a series of conceptual risk evaluations to assess the aggregate risk of the various produced water chemicals in several livestock species, including drinking water and dietary intake exposure pathways.

**Agriculture and soil biota.** Irrigation of crops and soil, or spillage to soil, risks impairing soil function by decreasing water permeation. Direct effects of irrigation water on sensitive crops may also occur. Non-food crops are often preferred for irrigation reuse in order to avoid direct ingestion pathways. Sunflowers (DaCosta et al. 2015, Sousa et al. 2017), castor beans (deMeneses et al. 2017), switchgrass and wormwood (*Artemisia*) (Burkhardt et al. 2015a, 2015b), and switchgrass and rapeseed (Pica et al. 2017) were exposed to untreated and treated produced waters with a wide variety of results related to product quality and yield, though most indicate at least short-term use with either processed produced water or untreated CBM produced water is acceptable in terms of plant performance, and soil: water ionic interactions. Reverse-osmosis (RO) treatment is not always beneficial to crops. Ferreira et al. (2015a) characterized soil mesofauna and found the produced water that had undergone RO had significant effects on species composition, richness and abundance. Sousa et al. 2016 examined the sunflowers grown in that study and found differences in mineral sequestration with filtered and treated (RO), favoring RO.

### **Underground Storage and Recovery (USR) in New Mexico**

The NM Office of the State Engineer indicates that surface storage of water in the high desert of New Mexico results in approximately 7% loss of stored water to evaporation. Above-ground tanks are costly to construct, require a large land footprint, and are not aesthetically pleasing. There are currently five active Underground Storage and Recovery (USR) projects in NM, at various stages of development and permitting. This summarizes the status of these projects undertaken by the Albuquerque Bernalillo County Water Utility Authority (ABCWUA), and the City of Rio Rancho. The Office of the State Engineer (OSE) reviews technical data and gives final approval for the project.

Below is a summary of four of the five USR projects permitted in New Mexico

## NM Underground Storage and Recovery (USR) Projects

Project Name	Applicant	Location	Max. annual Recharge (ac-ft)	Max. annual Recharge (kBWPD)	Status & Comments
Mariposa	City of Rio Rancho	North side of Albuquerque	336	7,142	Operating at less than 5% of design capacity.
Bear Canyon	Albuquerque Bernalillo County Water Authority	Albuquerque	3,000	63,764	First full scale USR permitted in NM. System not run in 2018 due to high nitrate in monitoring wells.
Rio Rancho Direct Injection	City of Rio Rancho	North side of Albuquerque	1,120	23,805	Operations began in October 2017.
Large Scale/DWTP	ABCWUA	Albuquerque	4,500	95,647	Demonstration phase started in Nov 2018.

Below is a summary of one of the USR projects.

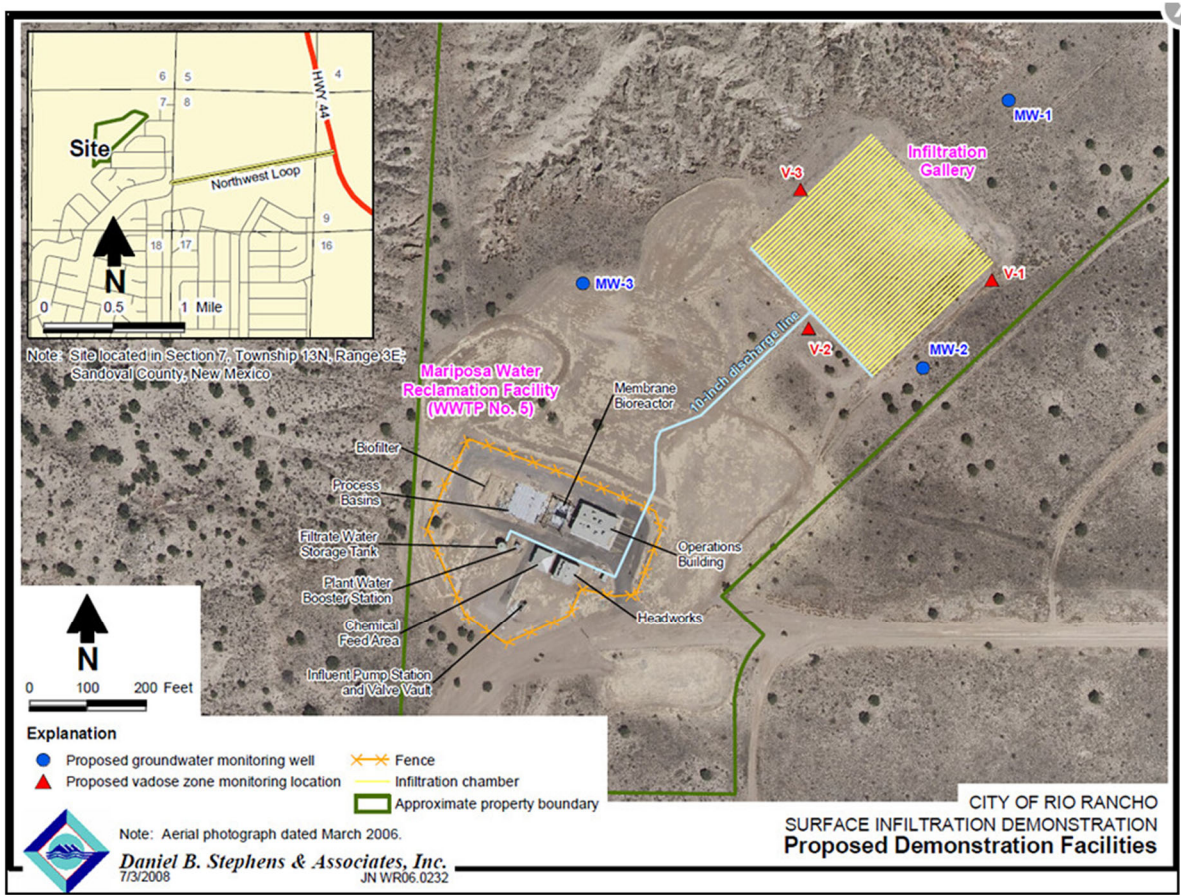

Mariposa Site

### Underground Storage and Recovery

Underground Storage and Recovery is legally different than Aquifer Storage and Recovery. There is a different water quality standard, according to Mike Hightower from the NMPWRC. The potential for USR could be significant in the Ogallala aquifer in the Jal, Eunice and Hobbs area of New Mexico.

Brackish aquifers could also be used as a storage location for desalinated produced water. Roger Peery from John Shomaker & Associates has studied brackish aquifers in New Mexico. [Peery 2016 presentation](#) [Peery 2004](#)

### Water Use for Washing Frac' Sand

Frac sand washing occurs at sand mines scattered around the Permian Basin, but there is a concentration of sand mines in Winkler County, east of Highway 18 near Kermit, TX. The mines wash and sieve the sand for frac' use in oil wells. The operations typically allow the fine clay particles to settle out of the water before it is reused. High Roller Sand indicated that they currently source make-up water from groundwater.

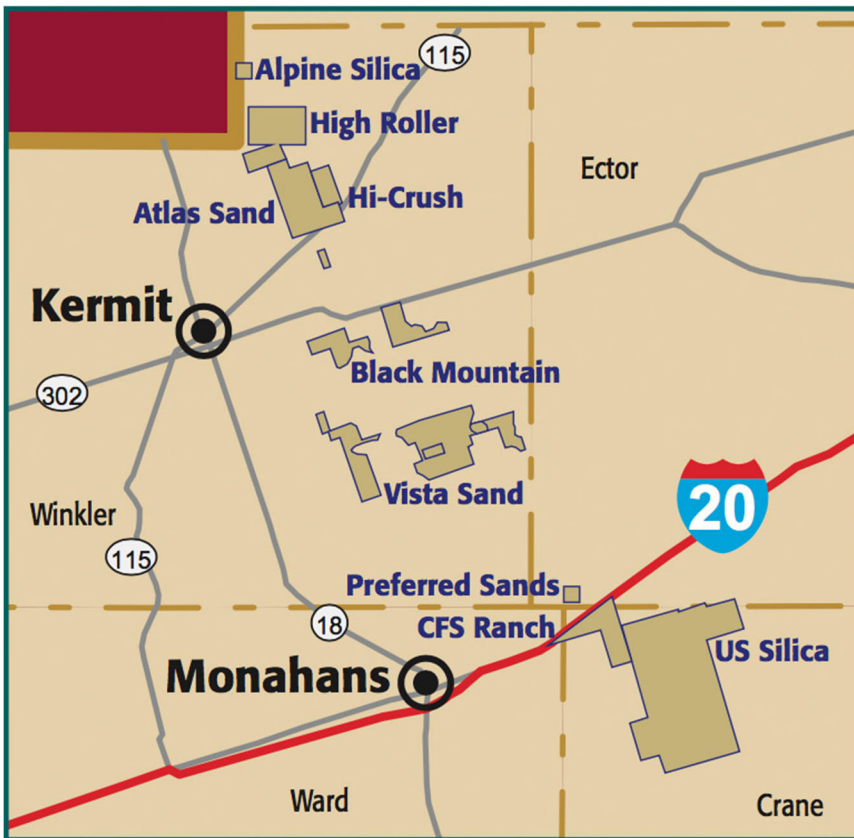

[Sand mines in Permian](#)

### Natural Gas Plants use of Water

Natural gas plants are scattered around the Permian basin. The plants are positioned downstream of the wells and tank batteries, but before the gas enters major natural gas sales pipelines. The plants use makeup water in their Amine and dehydration processing units. According to one natural gas midstream company, a typical gas plant may use less than 1,000 barrels of water per month. Thus, gas plant water use is too insignificant to be a target for produced water treatment that could be hundreds of times higher.

### Regulatory Control of Produced Water Reuse

If water is discharged to a “Water of the United States” (WOTUS), then the USEPA has jurisdiction and may be able to authorize a National Pollutant Discharge Elimination System (NPDES). A WOTUS may be defined as a large river down to an intermittently flowing stream.

Effective on September 1, 2019, the 86th Legislature passed Texas House Bill (HB) 2771, amending Section 26.131 of the Texas Water Code. The legislation transfers the authority to issue permits for the discharge of produced water, hydrostatic test water, and gas plant effluent resulting from certain oil and gas activities from the Railroad Commission of Texas (RRC) to the Texas Commission on Environmental Quality (TCEQ).

Additionally, on or before September 1, 2021, the TCEQ will seek federal delegation from the Environmental Protection Agency (EPA) to supplement or amend the Texas Pollutant Discharge Elimination System (TPDES) program to include delegation of the National Pollutant Discharge Elimination System (NPDES) permit authority for discharges of produced water, hydrostatic test water, and gas plant effluent.

Until the EPA delegates NPDES permit authority to the TCEQ, the RRC will continue to issue discharge permits. A federal NPDES permit may also be required for discharges to surface waters of the state.

[RRC TX produced water legislation](#)

A good summary of federal regulations of produced water discharge and EPA studies is in the GWPC produced water report starting on page 118. [GWPC PW report](#) The report includes examples of NPDES permits in Colorado, California and Wyoming. In the Wyoming case, lab analysis and reports for water proposed for discharge is required for 35 parameters with required detection limits. Examples of the standards for discharge of certain constituents include barium (2000 ug/L), boron (5000 ug/L), chloride (2000 mg/L or 230 mg/L for higher water classes), Radium 226 (5 or 60 pCi/L), and TDS (5,000 mg/L).

### **Permian Produced Water Desalination Project in 2015**

In 2015, Anadarko and Energy Water solutions partnered with Texas A&M AgriLife Research on a study in Pecos, Texas to investigate irrigation of cotton with desalinated produced water blended with well water (1:4 ratio) as compared to existing well water and also evaluate soil salinity parameters. The study found that that the blend did not reduce cotton yield or lint quality and may improve soil salinity as compared to the well water. The treated produced water of 98 ppm TDS was blended with 3218 ppm TDS groundwater to create a blended water with 2470 ppm TDS.

[http://www.owrb.ok.gov/2060/PWWG/Resources/Lewis\\_Katie.pdf](http://www.owrb.ok.gov/2060/PWWG/Resources/Lewis_Katie.pdf)

### **Colorado Study of treated Produced Water for Irrigation**

Researchers from Colorado State University and the United States Department of Agriculture (USDA) worked on a greenhouse study investigating the use of treated Denver-Julesburg Basin produced water for irrigation of two salt-tolerant biofuel crops, switchgrass and rapeseed. Researchers used different produced waters with varying total organic carbon (TOC) and total dissolved solids (TDS) levels and relative impacts on seedling emergence, biomass yield, plant height, leaf electrolyte leakages, and plant uptake over one growing season. The findings were that higher levels of both TOC and TDS had negative impacts on multiple endpoints, including yield and growth health. The study concluded that organic content is potentially a greater quality constraint than salinity. The authors hypothesized that such studies and related findings could inform regulatory decision-making on treatment standards for irrigation. For example, the authors discussed potential optimum treatment levels to at least 3500 mg/L TDS to maintain yield and plant health, removal of organic matter to less than 50 mg/L in order to keep leaf cell damage to less than 50 percent, and a TOC of less than 5 mg/l to keep a “sustainable biomass production rate.”



Nasim E. Pica, Ken Carlson, Jeffrey J. Steiner, and Reagan Waskom, "Produced Water Reuse for Irrigation of Non-Food Biofuel Crops: Effects on Switchgrass and Rapeseed Germination, Physiology and Biomass Yield," *Industrial Crops and Products* 100:65–76 (June 2017),

<https://www.sciencedirect.com/science/article/abs/pii/S0926669017301012?via%3Dihub>

## Roadspreading in Texas and New Mexico

Lea and Eddy Counties in New Mexico each have an estimated 700 miles of dirt roads. The roads are sometimes watered for dust suppression. It is widely accepted that a modest amount of salinity improves dust suppression. Potentially, very low salinity desalinated produced water (approximately 500 ppm TDS) could be blended with small amounts of produced water to create dust suppression water with a salinity around 15,000 ppm TDS. This water could be spread four times per year. If ½ inch of water were spread on 1400 miles of roads in the two counties four times per year, this would be an estimated 3.5 million barrels per year, or an average of 10,000 BWPD. Thus, this potential use is almost not significant for a large scale plant that could be 100,000 BWPD.

Tasker summarized road spreading regulations for various states in his 2018 article. The recent New Mexico produced water bill changed the rules for road spreading in that state.

Table S4. States with regulations permitting the use of O&G wastewater or solid wastes for road maintenance, dust suppression, de-icing, land spreading, or case-by-case beneficial use practices.

State	Regulation	Date adopted or banned	Use	Wastewater type	Requirements
AL	Code of Ala. § 9-17-6(c)(3)	Banned 05/23/2000 (current as of 09/25/2017)	N/A	N/A	N/A
CO	CO Regulation 404-1-907-c (2)(D)	Effective 08/01/71 (current as of 09/25/2017)	Road spreading	Produced water	<3,500 mg/L TDS
CT	Conn. Gen. Stat. § 22a-473	Banned 07/09/1987 (current as of 2017)	N/A	N/A	N/A
ID	IDAPA 20.07.02	Banned* effective 04/11/2015 (current as of 10/01/2017)	N/A	N/A	N/A
IL	Title 62 Illinois administrative code, Chapter 1, 240.945	Effective 07/09/2001 (current as of 08/11/2017)	Road maintenance	Crude oil	Crude oil bottom sediments with <10% produced water mix
IN	312 IAC 16-5-27(a)(1)	Effective 09/11/2000 (current as of 09/13/2017)	Dust suppression	Oil or fluid contaminated with oil	Fluid spread must not leave the roadbed
KS	K.S.A. § 55-904 (c) K.A.R. § 28-47.4	Effective 05/01/1983 (current as of 09/21/2017)	Dust suppression and road maintenance	Produced water	Map of roads, methods for spreading, application rates, amounts
MI	Mich. Admin. Code R 324.705	Effective 2004 (current as of 09/15/2017)	Dust suppression and deicing	Produced water	<500 ppm hydrogen sulfide; >20 g/L Cx <1 mg/L Benzene, Toluene, Ethylbenzene, and Xylene
MS	CMSR 26-000-002 R. 1.68 (VII)	Effective 01/01/1952 (current as of 09/06/2017)	Land spreading	NORM contaminated wastes	<600 uR/hr above background; Ra 226 and 228 < 5 pCi/gram after spreading
NE	Nebraska Admin. Code Title 267, Ch. 3, 022.16	Effective 01/01/2009 (current as of 11/01/2017)	Dust suppression and Deicing	Produced water	The estimated volume of fluids spread
NM	19.15.34.20 NMAC	Effective 03/31/2015 (current as of 08/29/2017)	By case	By case	Except as permitted under: 19.15.17 NMAC, 19.15.26.8 NMAC, 19.15.30 NMAC, 19.15.34 NMAC, or 19.15.36 NMAC
NY	6 NYCRR § 360-1.15 (d)	Effective 08/25/1993 (current as of 01/01/2017)	Dust suppression and deicing	Produced water only (No Marcellus)	Chemical analyses with chloride, sulfate, sodium, calcium, magnesium, lead, iron, barium, oil & grease, TDS (total dissolved solids), pH, benzene, ethylbenzene, toluene, and xylene; Maps; Application rates; Volume
ND	N.D. Admin. Code 33-24-02-02	Effective 01/01/1984 (current as of 10/01/2017)	Dust suppression and deicing	Produced water only	Chloride >75 g/L; Calcium + Magnesium >10 g/L; Chemical analyses including pH, specific conductivity, iron, manganese, sodium, potassium, phosphorus, SO <sub>4</sub> , HCO <sub>3</sub> , CO <sub>3</sub> , total dissolved solids (TDS), total alkalinity, oil and grease, aluminum, ammonia, arsenic, barium, boron, copper, chromium, lead, nickel, selenium and zinc; Maps; Application rates; Volumes
OH	ORC Ann. 1509.226	Effective 06/30/2010 (current as of 01/01/2017)	Dust suppression and deicing	Produced water only (no horizontal wells)	Locations, application rates, volumes, and gas well permit #'s
PA	25 Pa. Code § 78.63	Effective 07/26/1989 (current as of 08/05/2017)	Land spreading and dust control	Only production or treated brines (other than brines produced from shale formations)	Locations, application rates, monthly spreading reports, and chemical analyses including calcium, sodium, chloride, magnesium, and total dissolved solids
SD	ARSD 74:12:04:15	Effective 01/1/2012 (current as of 09/25/2017)	Dust suppression	Produced water	Prohibited unless permitted by the secretary for dust suppression
TN	Tenn. Comp. R. & Regs. R. 0400-45-06-.11 (10)(a)	Effective 12/11/2012 (current as of 08/01/2017)	By case	By case	N/A
TX	16 TAC §3.8	Banned* (01/01/1976) (current 09/30/2017)	N/A	N/A	N/A
VA	4 VAC 25-150-420	Effective September 25, 1991; current through August 1, 2017	Land spreading	Produced water	Road spreading is permitted through the same code that allows land spreading
WA	WAC § 344-12-225	Banned* (current as of 2003)	N/A	N/A	N/A
WV	Memorandum of Agreement, Dec. 22, 2011, WV	Effective 12/22/2011	Deicing	Produced water (no waters associated with hydraulic fracturing)	>200 g/L TDS; <175 g/L Cl <sub>2</sub> ; <91.5 g/L Na <sub>2</sub> S <sub>2</sub> O <sub>8</sub> ; 5.5 to 8 pH; Fe <10 mg/L; Barium <2 mg/L; lead <10 mg/L; O&G <10 mg/L; Benzene <0.5 mg/L; Ethylbenzene <0.7 mg/L; Toluene <1 mg/L; Xylene <1 mg/L
WY	WYWR 055-0001-4 § 1 (c)(1)(E)	Effective: 06/03/2015; current through August 31, 2017	Dust suppression and deicing	Produced water	Road spreading, land spreading, and landfarming of exploration and production wastes

<https://pubs.acs.org/doi/abs/10.1021/acs.est.8b00716>

In Texas, permits for roadspreading are not issued for beneficial use of produced water on roads, including lease roads, even though a process for permitting land disposal is in place. One paper studying roadspreading for Colorado concluded, "It's all "do-able", and could create savings for oil companies and a window of opportunity for subcontractors, but regulatorily speaking it would be difficult and move at a "snail's pace". Flowback is also heavy in particulates and TDS, which would worry regulators. Every company's flowback recipe is different, and robust sampling would be needed." Dust suppression in Texas is constricted by a tighter approval process than for other beneficial uses. Landowners must give written approval, which can cost a prospective roadspreader money, and a 10-day notice is required, which can open oil/gas companies up to liability. Trucking costs are prohibitive. East of the 98th Meridian,

produced water falls into a dual permit situation between TX and EPA Region 6. EPA evaluates toxicity/chemical analyses, then the Texas Railroad Commission reviews and approves permits (along with the EPA). [Colorado roadspreading](#)

Ohio's regulations for brine spreading do not contain details on water quality. <http://codes.ohio.gov/orc/1509.226>  
The Pennsylvania Department of Environmental Protection, which for years allowed municipalities to treat their roads with brine, ending the practice in May 2018, after it was sued by a Warren County resident. Before the decision, over a dozen counties in Western Pennsylvania used oil and gas wastewater on roads, and at least 13 other states — including Ohio, Michigan, West Virginia and New York — allowed the practice, according to the Penn State study. But it was especially common in northwestern Pennsylvania. In 2016, municipalities spread more than 11 million gallons of brine on roads in Pennsylvania, 96 percent of it in northwest part of the state. That represented 6 percent of the Pennsylvania conventional oil and gas industry's wastewater. Roadspreading Study PA

### **Summary of New Mexico's Produced Water Act – Including Roadspreading**

- Eliminates legal vulnerabilities to New Mexico's surface/ground waters that existed prior to July 1, 2019, through:
  - Affirmative state permitting requirements;
  - Affirmative requirements for financial assurance; and
  - Clarified liability for spills.
- Removes obstacles to recycling of produced water.
- Gives EMNRD much-needed penalty authority.
- Explicitly requires that any use of produced water outside the oil and gas industry be regulated by NMED.
- Requires that the New Mexico Water Quality Control Commission (WQCC) adopt regulations for the "discharge, handling, transport, storage, and recycling or treatment of produced water or byproduct thereof outside the oilfield."
- Does not specify what these regulations shall be or what the WQCC determines protective of water quality.



# Produced Water Act Implementation

- ✗ NMED is not currently authorizing the discharge of *treated* produced water for any purpose, including:
  - ✗ Surface waters
  - ✗ Drinking water and aquifer storage
  - ✗ Livestock watering
  - ✗ Irrigation for any crops, including food crops
  - ✗ Dust or ice control on roads
  - ✗ Construction
- ✗ NMED will **never** authorize *untreated* produced water to be used outside of oil and gas for any purpose

- ✓ NMED is preparing to implement HB 546
- ✓ NMED is partnering with research and academic institutions to fill critical science and technology gaps related to the safe treatment and use of produced water
- ✓ NMED is engaging the public to talk about the Produced Water Act and developing informative resources on the topic

<https://www.env.nm.gov/new-mexico-produced-water/>

16

NMED's path for produced water regulations:

- Develop rules that prohibit untreated produced water use(s) outside of the oil and gas industry (e.g., road spreading).
- Develop rules that require companies to analyze and disclose the chemical constituents in produced water intended for treatment and use outside of the oil and natural gas industry.
- Over time and as the science dictates, develop rules for the "discharge, handling, transport, storage, and recycling or treatment of produced water or byproduct thereof outside the oilfield" (excerpt from HB 546).



## State Agency Contacts

### NMED contacts for treatment of produced water for off oil field use:

- Rebecca Roose, Water Protection Division Director, [Rebecca.Roose@state.nm.us](mailto:Rebecca.Roose@state.nm.us)
- Annie Maxfield, Assistant General Counsel, [Annie.Maxfield@state.nm.us](mailto:Annie.Maxfield@state.nm.us)

### EMNRD contacts for management of produced water within the oil field:

- Adrienne Sandoval, Oil Conservation Division Director, [Adrienne.Sandoval@state.nm.us](mailto:Adrienne.Sandoval@state.nm.us)
- Bill Brancard, General Counsel, [Bill.Brancard@state.nm.us](mailto:Bill.Brancard@state.nm.us)

### OSE contacts for water rights issues related to produced water management:

- John Romero, Water Resource Allocation Program Director, [John.Romero2@state.nm.us](mailto:John.Romero2@state.nm.us)
- Owen Kellum, Administrative Litigation Unit Attorney, [Owen.Kellum@state.nm.us](mailto:Owen.Kellum@state.nm.us)

[NMED presentation](#)

## Who Regulates Produced Water in New Mexico?

Energy, Minerals, and Natural Resources Department (EMNRD)	➡	Produced water disposal and reuse <b>within</b> the oil field
New Mexico Environment Department (NMED)	➡	Treated produced water use <b>outside</b> oil field
Office of the State Engineer (OSE)	➡	<b>No</b> permit required

[NM produced water Fact sheet](#)

## **New Mexico Regulations on Water Quality & Discharge (Selected portions)**

### 20.6.2.2101 **GENERAL REQUIREMENTS:**

- A. Except as otherwise provided in Sections 20.6.2.2000 through 20.6.2.2201 NMAC, no person shall cause or allow effluent to discharge to a watercourse if the effluent as indicated by:
- (1) any two consecutive daily composite samples;
  - (2) more than one daily composite sample in any thirty-day period (in which less than ten (10) daily composite samples are examined);
  - (3) more than ten percent (10%) of the daily composite samples in any thirty-day period (in which ten (10) or more daily composite samples are examined); or
  - (4) a grab sample collected during flow from an intermittent or infrequent discharge does not conform to the following:
    - (a) Bio-chemical Oxygen Demand (BOD) Less than 30 mg/l
    - (b) Chemical Oxygen Demand (COD) Less than 125 mg/l
    - (c) Settleable Solids Less than 0.5 mg/l
    - (d) Fecal Coliform Bacteria Less than 500 organisms per 100 ml
    - (e) pH Between 6.6 and 8.6

### 20.6.2.2102 **RIO GRANDE BASIN--COMMUNITY SEWERAGE SYSTEMS:**

- A. No person shall cause or allow effluent from a community sewerage system to discharge to a watercourse in the Rio Grande Basin between the headwaters of Elephant Butte Reservoir and Angostura Diversion Dam as described in Subsection E of this Section if the effluent, as indicated by:
- (1) any two consecutive daily composite samples;
  - (2) more than one daily composite sample in any thirty-day period (in which less than ten (10) daily composite samples are examined);
  - (3) more than ten percent (10%) of the daily composite samples in any thirty-day period (in which ten (10) or more daily composite samples are examined); or
  - (4) a grab sample collected during flow from an intermittent or infrequent discharge does not conform to the following:
    - (a) Bio-chemical Oxygen Demand (BOD) Less than 30 mg/l
    - (b) Chemical Oxygen Demand (COD) Less than 80 mg/l
    - (c) Settleable Solids Less than 0.1 mg/l
    - (d) Fecal Coliform Bacteria Less than 500 organisms per 100 ml
    - (e) pH Between 6.6 and 8.6

### 20.6.2.3103 **STANDARDS FOR GROUND WATER OF 10,000 mg/l TDS CONCENTRATION OR LESS:**

- A. **Human Health Standards**

**(1) Numerical Standards**

<b>(a)</b>	Antimony (Sb) (CAS 7440-36-0).....	0.006 mg/l
<b>(b)</b>	Arsenic (As) (CAS 7440-38-2).....	0.01 mg/l
<b>(c)</b>	Barium (Ba) (CAS 7440-39-3).....	2 mg/l
<b>(d)</b>	Beryllium (be) (CAS 7440-41-7).....	0.004 mg/l
<b>(e)</b>	Cadmium (Cd) (CAS 7440-43-9).....	0.005 mg/l
<b>(f)</b>	Chromium (Cr) (CAS 7440-47-3).....	0.05 mg/l
<b>(g)</b>	Cyanide (CN) (CAS 57-12-5).....	0.2 mg/l
<b>(h)</b>	Fluoride (F) (CAS 16984-48-8).....	1.6 mg/l
<b>(i)</b>	Lead (Pb) (CAS 7439-92-1).....	0.015 mg/l
<b>(j)</b>	Total Mercury (Hg) (CAS 7439-97-6).....	0.002 mg/l
<b>(k)</b>	Nitrate (NO <sub>3</sub> as N) (CAS 14797-55-8).....	10.0 mg/l
<b>(l)</b>	Nitrite (NO <sub>2</sub> as N) (CAS 10102-44-0).....	1.0 mg/l
<b>(m)</b>	Selenium (Se) (CAS 7782-49-2).....	0.05 mg/l
<b>(n)</b>	Silver (Ag) (CAS 7440-224).....	0.05 mg/l
<b>(o)</b>	Thallium (Tl) (CAS 7440-28-0).....	0.002 mg/l
<b>(p)</b>	Uranium (U) (CAS 7440-61-1).....	0.03 mg/l
<b>(q)</b>	Radioactivity: Combined Radium-226 (CAS 13982-63-3) and Radium-228 (CAS 15262-20-1).....	5 pCi/l
<b>(r)</b>	Benzene (CAS 71-43-2).....	0.005 mg/l
<b>(s)</b>	Polychlorinated biphenyls (PCB's) (CAS 1336-36-3).....	0.0005 mg/l
<b>(t)</b>	Toluene (CAS 108-88-3).....	1 mg/l
<b>(u)</b>	Carbon Tetrachloride (CAS 56-23-5).....	0.005 mg/l
<b>(v)</b>	1,2-dichloroethane (EDC) (CAS 107-06-2).....	0.005 mg/l
<b>(w)</b>	1,1-dichloroethylene (1,1-DCE) (CAS 75-35-4).....	0.007 mg/l
<b>(x)</b>	tetrachloroethylene (PCE) (CAS 127-18-4).....	0.005 mg/l
<b>(y)</b>	trichloroethylene (TCE) (CAS 79-01-6).....	0.005 mg/l
<b>(z)</b>	ethylbenzene (CAS 100-41-4).....	0.7 mg/l
<b>(aa)</b>	total xylenes (CAS 1330-20-7).....	0.62 mg/l
<b>(bb)</b>	methylene chloride (CAS 75-09-2).....	0.005 mg/l
<b>(cc)</b>	chloroform (CAS 67-66-3).....	0.1 mg/l
<b>(dd)</b>	1,1-dichloroethane (CAS 75-34-3).....	0.025 mg/l
<b>(ee)</b>	ethylene dibromide (EDB) (CAS 106-93-4).....	0.00005 mg/l
<b>(ff)</b>	1,1,1-trichloroethane (CAS 71-55-6).....	0.2 mg/l
<b>(gg)</b>	1,1,2-trichloroethane (CAS 79-00-5).....	0.005 mg/l
<b>(hh)</b>	1,1,2,2-tetrachloroethane (CAS 79-34-5).....	0.01 mg/l
<b>(ii)</b>	vinyl chloride (CAS 75-01-4).....	0.002 mg/l
<b>(jj)</b>	PAHs: total naphthalene (CAS 91-20-3) plus monomethylnaphthalenes ...	0.03 mg/l
<b>(kk)</b>	benzo-a-pyrene (CAS 50-32-8).....	0.0002 mg/l
<b>(ll)</b>	cis-1,2-dichloroethene (CAS 156-59-2).....	0.07 mg/l
<b>(mm)</b>	trans-1,2-dichloroethene (CAS 156-60-5).....	0.1 mg/l
<b>(nn)</b>	1,2-dichloropropane (PDC) (CAS 78-87-5).....	0.005 mg/l
<b>(oo)</b>	styrene (CAS 100-42-5).....	0.1 mg/l
<b>(pp)</b>	1,2-dichlorobenzene (CAS 95-50-1).....	0.6 mg/l
<b>(qq)</b>	1,4-dichlorobenzene (CAS 106-46-7).....	0.075 mg/l
<b>(rr)</b>	1,2,4-trichlorobenzene (CAS 120-82-1).....	0.07 mg/l
<b>(ss)</b>	pentachlorophenol (CAS 87-86-5).....	0.001 mg/l

(tt) atrazine (CAS 1912-24-9).....0.003 mg/l

(2) **Standards for Toxic Pollutants.** A toxic pollutant shall not be .....

**B. Other Standards for Domestic Water Supply**

(1) Chloride (Cl) (CAS 16887-00-6).....250.0 mg/l

(2) Copper (Cu) (CAS 7440-50-8).....1.0 mg/l

(3) Iron (Fe) (CAS 7439-89-6).....1.0 mg/l

(4) Manganese (Mn) (CAS 7439-96-5).....0.2 mg/l

(5) Phenols .....0.005 mg/l

(6) Sulfate (SO<sub>4</sub>) (CAS 14808-79-8).....600.0 mg/l

(7) Total Dissolved Solids (TDS) TDS.....1000.0 mg/l

(8) Zinc (Zn) (CAS 7440-66-6).....10.0 mg/l

(9) pH.....between 6 and 9

(10) Methyl tertiary-butyl ether (MTBE) (CAS 1634-04-4).....0.1 mg/l

**C. Standards for Irrigation Use - Ground water shall meet the standards of Subsection A, B, and C of this section unless otherwise provided.**

(1) Aluminum (Al) (CAS 7429-90-5).....5.0 mg/l

(2) Boron (B) (CAS 7440-42-8).....0.75 mg/l

(3) Cobalt (Co) (CAS 7440-48-4).....0.05 mg/l

(4) Molybdenum (Mo) (CAS 7439-98-7).....1.0 mg/l

(5) Nickel (Ni) (CAS 7440-02-0).....0.2 mg/l

## **Key Sections of NM Water Regulations**

**20.6.2.2001 PROCEDURES FOR CERTIFICATION OF FEDERAL NATIONAL POLLUTANT DISCHARGE ELIMINATION SYSTEM (NPDES) PERMITS:**

**20.6.2.2002 PROCEDURES FOR CERTIFICATION OF FEDERAL PERMITS FOR DISCHARGE OF DREDGED OR FILL MATERIAL:**

**20.6.2.3107 MONITORING, REPORTING, AND OTHER REQUIREMENTS**

**20.6.2.3108 PUBLIC NOTICE AND PARTICIPATION:**

**20.6.2.3109 SECRETARY APPROVAL, DISAPPROVAL, MODIFICATION OR TERMINATION OF DISCHARGE PERMITS, AND REQUIREMENT FOR ABATEMENT PLANS:**

<http://164.64.110.134/parts/title20/20.006.0002.html> (This link applies to the NM regs above.)

## **Landfarming with produced water in Texas**

The Texas Railroad Commission authorizes landfarming of the following oil and gas wastes without a permit by Statewide Rule 8(d)(3), provided the wastes are disposed of on the same oil or gas lease where they are generated, and provided written consent of the surface owner of the tract where the landfarming will occur is obtained:

- water base drilling fluids with a chloride concentration of 3000 mg/l or less;
- drill cuttings,
- sands and silts obtained while using water base drilling fluids with a chloride concentration of 3000 mg/l or less; and
- wash water used for cleaning drill pipe and other equipment at the well site.

Other landfarming operations require a permit. Any facility land-applying oil-based drilling fluids and associated cuttings will require a permit. Texas RRC on landfarming

## **Ground Water Protection Council's Produced Water Report**

The Ground Water Protection Council (GWPC) report on Produced Water was published in June, 2019. Module 1 covers regulations on produced water. Module 2 is a deep dive into reuse within oil and gas operations. Module 3 examines current and future reuse of produced water outside oil and gas operations. Module 3 sites how potential options for the treatment and reuse of produced water outside the oil and gas industry can be sorted into three primary categories: land application (e.g., irrigation, roadspreading), introduction to water bodies (e.g., discharges to surface water, injection or infiltration to ground water) and other industrial uses (e.g., industrial feed streams, product or mineral mining). Some options, such as surface water discharge, are active in limited circumstances today. Others, such as utilizing treated produced water in other industrial systems, are under investigation or theoretical.

The GWPC reports drivers for considering produced water reuse differ for industry and other stakeholders. States and regulators may be driven to investigate reuse for reasons ranging from drought and groundwater depletion to disposal-related induced seismicity. For the oil and gas industry, operational and economic considerations, such as a reduction in nearby cost-effective disposal capacity, may drive a search for produced water management alternatives including reuse.

Module 3 emphasizes a “fit-for purpose” treatment approach for the majority of anticipated reuse scenarios. Produced water quantity and quality is not uniform, and neither are the circumstances of its potential treatment and reuse. Under a “fit-for-purpose” mindset, research, treatment decisions, risk management strategies, and in some cases even approval processes should be tailored to address a particular produced water for a particular type of reuse. Not all reuse scenarios will require the same analysis or approach.

The report suggests that treatment can take many forms, and the particular treatment utilized will depend on the desired quality needed to support the intended end use. Designing an appropriate treatment train will play a vital role in reducing potential risks to health and the environment. Treatment of produced water for reuse objectives that demand consistent high quality can present unique challenges such as managing variability; significantly reducing high total dissolved solid levels, difficult-to-treat organic constituents, and naturally occurring radioactive material; and handling residuals.

The GWPC report also advocates risk-based decision-making in assessing and reducing risks. The report also includes an extensive literature review.

Table 3-1: Pennsylvania WMGR123 Appendix A: Maximum Concentrations – Derived from Drinking Water Standards, Water Quality Standards for Rivers and Streams, and Typical Values Observed in Fresh Water Rivers and Streams (reformatted)

Constituent	Limit	Constituent	Limit
Aluminum	0.2 mg/L	Manganese	0.2 mg/L
Ammonia	2 mg/L	MBAS (Surfactants)	0.5 mg/L
Arsenic	10 µg/L	Methanol	3.5 mg/L
Barium	2 mg/L	Molybdenum	0.21 mg/L
Benzene	0.12 µg/L	Nickel	30 µg/L
Beryllium	4 µg/L	Nitrite-Nitrate Nitrogen	2 mg/L
Boron	1.6 mg/L	Oil & Grease	ND
Bromide	0.1 mg/L	pH	6.5-8.5 SU
Butoxyethanol	0.7 mg/L	Radium-226 + -228	5 pCi/L (combined)
Cadmium	0.16 µg/L	Selenium	4.6 µg/L
Chloride	25 mg/L	Silver	1.2 µg/L
COD	15 mg/L	Sodium	25 mg/L
Chromium	10 µg/L	Strontium	4.2 mg/L
Copper	5 µg/L	Sulfate	25 mg/L
Ethylene Glycol	13 µg/L	Toluene	0.33 µg/L
Gross Alpha	15 pCi/L	TDS	500 mg/L
Gross Beta	1,000 pCi/L	TSS	45 mg/L
Iron	0.3 mg/L	Uranium	30 µg/L
Lead	1.3 µg/L	Zinc	65 µg/L
Magnesium	10 mg/L		

The table above is from the GWPC report on page 122 and shows Pennsylvania’s water quality standard for rivers and streams.

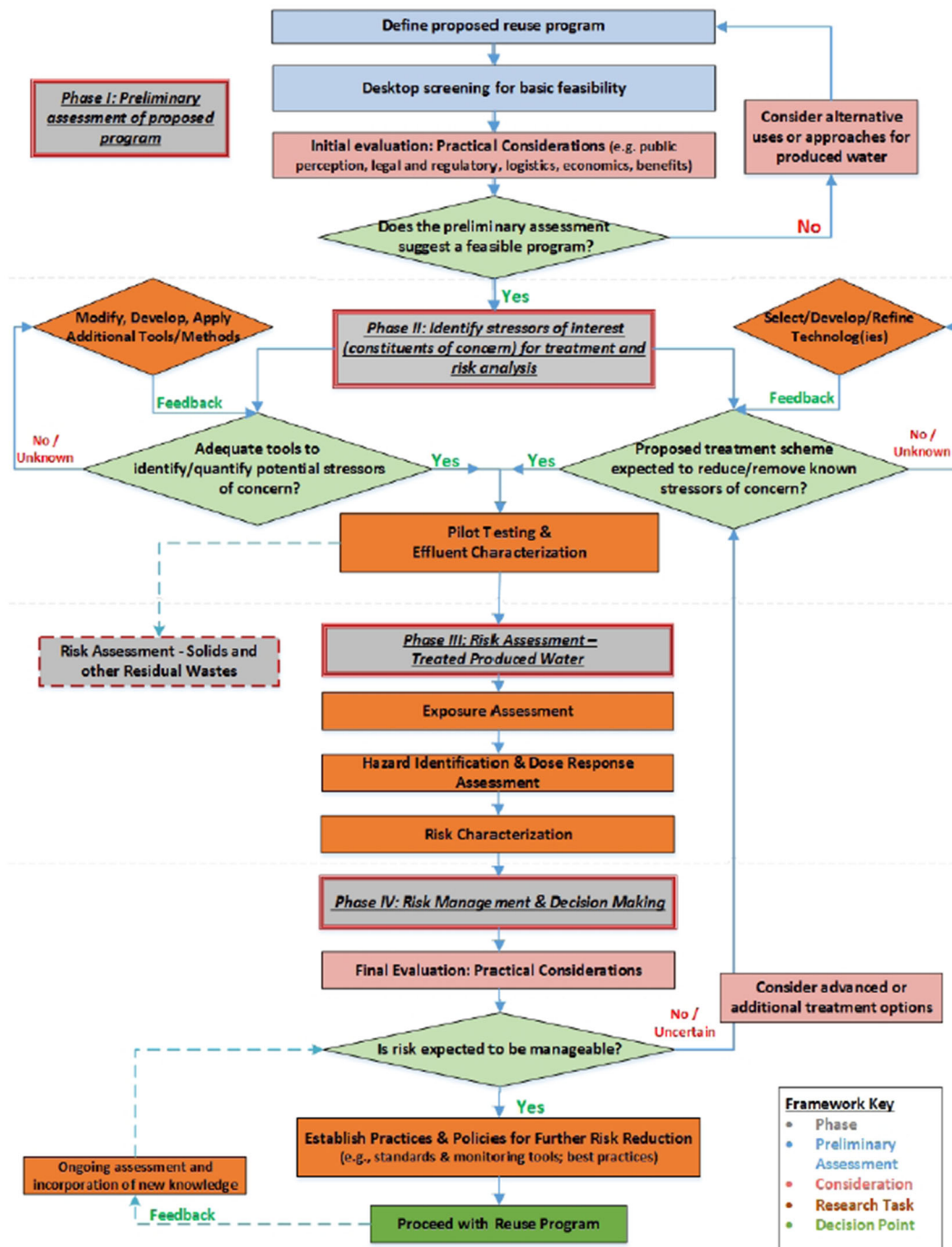

Figure 3-9: Framework for Research, Evaluation and Decision-Making

The diagram above is the summary of the GWPC’s framework for research, evaluation and decision-making, from page 129.

### California’s Use of Produced Water on Crops

For decades, California has approved the use of reclaimed produced water from certain oil and natural gas field as a best practice to augment irrigation water supplies. A 2016 report from the California Water Boards Central Valley Regional



Water Quality Control Board Food Safety Expert Panel presents the results of a human health risk assessment performed to establish risk-based comparison (RBC) levels of chemicals of interest (COIs) in irrigation water containing reclaimed produced water. These RBC levels are intended for use as benchmarks for rapidly assessing the acceptability and suitability of reclaimed produced water from oil and natural gas fields for blending and use in agricultural irrigation.

The California Water Board derived the recommended RBC levels for blended irrigation water using the most stringent target risk thresholds applied by the United States Environmental Protection Agency (USEPA) and the State of California. The levels are based on a theoretical upper-bound incremental cancer risk of one in one million, which is 100 times lower than the upper end of the acceptable risk range applied by the USEPA and other agencies, and an acceptable daily intake for theoretical non-cancer effects. The levels were developed specifically for irrigation water for six primary crops grown in the central California district: almonds, pistachios, citrus, grapes, potatoes and carrots. The report states that because of a multitude of conservative assumptions in the process, the recommended RBC levels are likely to be more restrictive (lower) than the actual threshold limits that would be protective of crop consumers.

### Recommended Irrigation Water Risk-Based Comparison (RBC) Levels (mg/L)

Inorganics		Organics	
Arsenic	0.1	Acetone	20,000
Barium	2,000	Benzene	0.7
Boron	70	Ethylbenzene	6
Cadmium	70	Ethylene Glycol	5,000
Chromium (VI)	0.4	Methylene Chloride	2
Fluoride	700	Naphthalene	200
Mercury	20	PAHs	0.02
Thallium	10	Toluene	500
Zinc	2,000	Total Petroleum Hydrocarbons	200
		Trimethylbenzene	200
		Xylenes	1,000

mg/L = Milligrams per liter

[https://www.waterboards.ca.gov/centralvalley/water.../erm\\_riskassrpt.pdf](https://www.waterboards.ca.gov/centralvalley/water.../erm_riskassrpt.pdf)

The California Regional Water Quality Control Board, Central Valley Region, Order. R5-2012-0058 contains an oil and grease limit for Chevron discharges to Cawelo's Reservoir B. of 35 milligrams per liter (mg/L). Analysis in a 2016 report indicated that the historical oil and grease data that has been collected and reported to the Water Board revealed that the maximum recorded concentration of oil and grease in the water was 29 mg/L. This water has been used for blending and irrigation. The report provided details of the organics in the table below:

Table 1. Analytical Results Summary, Volatile Organic Compounds, Semivolatile Organic Compounds, and Total Petroleum Hydrocarbons

Well/Sample ID	Sample ID	Volatile Organic Compounds <sup>1</sup> (ug/L)							Polycyclic Aromatic Hydrocarbons <sup>2</sup> (ug/L)							TPH <sup>3</sup> (mg/L)
		Acetone	Benzene	Ethylbenzene	m,p-Xylene	o-Xylene	Toluene	Total Xylenes	Acenaphthene	Acenaphthylene	Chrysene	Fluorene	Naphthalene	Phenanthrene	Pyrene	
Plant 36	W039	31	0.47 J	0.71	2.6	1.3	0.67	3.9	0.63	<0.098	<0.098	0.37	0.11 J	0.38	<0.098	0.12
Polish Pond	W042	86	0.33 J	0.39 J	1.3	0.74	0.49 J	2.0	0.53	<0.097	<0.097	0.29	0.11 J	0.27	<0.097	0.19
Polish Pond	W043 <sup>4</sup>	100	0.31 J	0.38 J	1.2	0.59	0.47 J	1.8	0.57	<0.097	<0.097	0.35	0.12 J	0.28	<0.097	0.097
Reservoir B	W044	150	<0.25	0.25 J	0.75 J	0.43 J	0.39 J	1.2	0.49	<0.097	<0.097	0.50	<0.097	0.29	<0.097	0.15
Reservoir B Outflow	W045	50	<0.25	<0.25	<0.50	<0.25	<0.25	<0.50	<0.096	<0.096	<0.096	<0.096	<0.096	<0.096	<0.096	0.080

Notes:

1. Volatile organic compounds analyzed using U.S. EPA Method 8260B.
2. Polycyclic aromatic hydrocarbons analyzed using U.S. EPA Method 8270C SIM.
3. Total Petroleum Hydrocarbons (TPH: carbon range C29-C40) analyzed using U.S. EPA Method 8015B.
4. Duplicate sample of W042.

Abbreviations:

<= less than the Reporting Limit.  
 J = result is less than the RL but greater than or equal to the MDL and the concentration is an approximate value  
 TPH = total petroleum hydrocarbons  
 ug/L = micrograms per liter

The report

conclusions included this table breakout box:

#### Irrigation water provided by the District:

- Contained traces of organic chemicals at concentrations that are at or below drinking water quality standards
- Does not pose a health threat to fruit trees
- Does not pose a health threat to consumers of agricultural products
- Is safe for irrigation of fruit trees

[-https://www.waterboards.ca.gov/rwqcb5/water\\_issues/oil\\_fields/food\\_safety/data/studies/cawelo\\_irrstudy.pdf](https://www.waterboards.ca.gov/rwqcb5/water_issues/oil_fields/food_safety/data/studies/cawelo_irrstudy.pdf)

A total of 1,242 groundwater samples in the Cawelo GSA have TDS analyses. The majority (63%) of the samples have TDS concentrations less than 500 mg/L, 29% of samples are between 500 and 1,000 mg/L and 8% of samples are greater than 1,000 mg/L (Table 3-3). The TDS concentrations in groundwater of the Cawelo GSA generally meet drinking water quality standards and irrigation requirements. This low level of TDS is highly unusual for oil and gas formations. Because of the low TDS, the produced water only requires oil separation to meet the state criteria.

[Chevron California produced water 2019 report](#)

[https://www.google.com/url?sa=t&rct=j&q=&esrc=s&source=web&cd=6&ved=2ahUKewidpMmxhdfoAhVIKKwKHbToCtwQFjAFegQIBhAB&url=https%3A%2F%2Fwww.cawelowd.org%2Fwp-content%2Fuploads%2F2019%2F08%2Fadmin-draft-text\\_cawelo\\_gsp\\_aug12-2019.pdf&usq=AOvVaw2yPdctfOFwN6KcZD8S9DVV](https://www.google.com/url?sa=t&rct=j&q=&esrc=s&source=web&cd=6&ved=2ahUKewidpMmxhdfoAhVIKKwKHbToCtwQFjAFegQIBhAB&url=https%3A%2F%2Fwww.cawelowd.org%2Fwp-content%2Fuploads%2F2019%2F08%2Fadmin-draft-text_cawelo_gsp_aug12-2019.pdf&usq=AOvVaw2yPdctfOFwN6KcZD8S9DVV)

Recent article on Kern County California PW use [California PW use](#)

**Agricultural Reuse of Produced Water in California.** California produced approximately 175 million barrels of oil onshore in 2016, along with nearly 2.73 billion barrels of produced water.\* Interest in produced water reuse has grown due in large part to the ongoing drought. Reusing produced water in irrigation, which has occurred in eastern Kern County for over three decades, has expanded in recent years.\*\* Produced water here contains low concentrations of total dissolved solids and boron, making reuse more feasible than in areas with higher salinity.

Concern over produced water reuse for agricultural irrigation has arisen in recent years and prompted the Central Valley Regional Water Quality Control Board (Central Valley Water Board) to develop a Food Safety Expert Panel (Panel). The Panel's purpose is to guide sample collection and analytical methods for field studies, assess results, identify data gaps, and procure practical outcomes regarding produced water management. The Central Valley Water Board will consider the Panel's recommendations to regulate produced water reuse. Panel meetings are typically held quarterly and are open to the public. The meetings are attended by industry and environmental stakeholders as well as regulators.

In the three years since the Panel's inception, multiple crop sampling events and an irrigation water quality evaluation were conducted in vicinity of the Cawelo Water District, where produced water is currently reused to irrigate crops under a permit issued by the Central Valley Water Board. The Central Valley Water Board has also received chemical disclosures from operators and suppliers through informational orders (California Code § 13267). These disclosures are available to the public on the Central Valley Water Board's website<sup>†</sup> and are being evaluated and incorporated into future sampling efforts. The oilfield chemical additives evaluation is ongoing since several chemicals do not have standardized sampling methods, making water monitoring and crop plant uptake quantification difficult. However, community representatives and Panel members share an interest in evaluating and quantifying chemical additives when feasible and conducting health risk evaluations before the Panel provides its final recommendations.

\* Department of Conservation, Division of Oil, Gas, & Geothermal Resources. 2017. 2016 Report of California Oil and Gas Production Statistics. [ftp://ftp.consrv.ca.gov/pub/oil/annual\\_reports/2016/2016\\_Annual\\_Report\\_Final\\_Corrected2.pdf](ftp://ftp.consrv.ca.gov/pub/oil/annual_reports/2016/2016_Annual_Report_Final_Corrected2.pdf).

\*\* Food Safety - Oil Field Wastewater Reuse Expert Panel. 2017. Project Charter. [https://www.waterboards.ca.gov/centralvalley/water\\_issues/oil\\_fields/food\\_safety/information/offsep\\_charter.pdf](https://www.waterboards.ca.gov/centralvalley/water_issues/oil_fields/food_safety/information/offsep_charter.pdf).

<sup>†</sup> Central Valley Regional Water Quality Control Board. 2018. Oil Field - Food Safety. [https://www.waterboards.ca.gov/centralvalley/water\\_issues/oil\\_fields/food\\_safety/index.html](https://www.waterboards.ca.gov/centralvalley/water_issues/oil_fields/food_safety/index.html).

The California PW summary above is from the GWPC report, page 157.

Southwest Energy received an NPDES permit to discharge water from its Arkansas field. The discharge limits were part of a case study in the GWPC report on page 187 and shown below.

Such discharges shall be limited and monitored by the permittee as specified below:

Effluent Characteristics	Discharge Limitations				Monitoring Requirements	
	Mass (lbs/day, unless otherwise specified)		Concentration (mg/l, unless otherwise specified)		Frequency	Sample Type
	Monthly Avg.	Daily Max.	Monthly Avg.	Daily Max.		
Flow	N/A	N/A	Report, MGD	Report, MGD	daily	totalizing meter
Carbonaceous Biochemical Oxygen Demand (CBOD <sub>5</sub> )	14.0	21.0	10.0	15.0	once/month	grab
Total Suspended Solids (TSS)	21.0	31.5	15.0	22.5	once/month	grab
Ammonia Nitrogen (NH <sub>3</sub> -N)						
(April)	7.8	7.8	5.6	5.6	daily	grab
May-Oct)	7.0	10.5	5.0	7.5	daily	grab
(Nov-March)	14.0	21.0	10.0	15.0	daily	grab
Dissolved Oxygen (DO)	N/A	N/A	2.0 (Inst.Min.)		daily	grab
Chlorides	131.7	197.6	94	141.0	daily	composite
Sulfates	28.0	42.0	20.0	30.0	daily	composite
Total Dissolved Solids (TDS)	496.0	744.0	354.0	531.0	daily	composite
Oil and Grease (O&G)	14.0	21.0	10.0	15.0	daily	grab
Arsenic, Total Recoverable (Ar)	1.9	4.1	1.33	2.95	once/month	composite
Cadmium, Total Recoverable (Cd)						
(May-Oct)	0.0026	0.0052	1.8 µg/l	3.7 µg/l	once/month	composite

Effluent Characteristics	Discharge Limitations				Monitoring Requirements	
	Mass (lbs/day, unless otherwise specified)		Concentration (mg/l, unless otherwise specified)		Frequency	Sample Type
	Monthly Avg.	Daily Max.	Monthly Avg.	Daily Max.		
(Nov-April)	0.0075	0.015	5.4 µg/l	10.8 µg/l	once/month	composite
Chromium III, Total Recoverable (Cr <sub>3</sub> )						
(May-Oct)	0.41	0.83	295.4 µg/l	592.8 µg/l	once/month	composite
(Nov-April)	1.2	2.4	860.1 µg/l	1725.7 µg/l	once/month	composite
Chromium (VI) (Cr <sub>6</sub> )						
(May-Oct)	0.017	0.033	11.8 µg/l	23.7 µg/l	once/month	composite
(Nov-April)	0.038	0.076	26.9 µg/l	54.1 µg/l	once/month	composite
Chromium, Total Recoverable (Cr)	0.45	1.05	323 µg/l	746 µg/l	once/month	composite
Cobalt, Total Recoverable (Cu)	26.3	79.0	18.8 µg/l	56.4 µg/l	once/month	composite
Copper, Total Recoverable (Hg)						
(May-Oct)	0.013	0.026	9.2 µg/l	18.5 µg/l	once/month	composite
(Nov-April)	0.026	0.053	18.8 µg/l	37.8 µg/l	once/month	composite
Lead, Total Recoverable (Pb)						
(May-Oct)	0.0038	0.0076	2.7 µg/l	5.4 µg/l	once/month	composite
(Nov-April)	0.011	0.022	7.9 µg/l	15.8 µg/l	once/month	composite
Mercury, Total Recoverable (Hg)						
(May-Oct)	0.000019	0.00003 8	0.013 µg/l	0.027 µg/l	once/month	composite
(Nov-April)	0.000055	0.00001 1	0.039 µg/l	0.078 µg/l	once/month	composite
Nickel, Total Recoverable (Ni)						
(May-Oct)	0.14	0.27	97.0 µg/l	194.6 µg/l	once/month	composite
(Nov-April)	0.40	0.79	282.3 µg/l	566.4 µg/l	once/month	composite

Table I-A-1 Effluent Limitations and Monitoring Requirements. Source: After USEPA

Effluent Characteristics	Discharge Limitations				Monitoring Requirements	
	Mass (lbs/day, unless Otherwise specified)		Concentration (mg/l, unless Otherwise specified)		Frequency	Sample Type
	Monthly Avg.	Daily Max.	Monthly Avg.	Daily Max.		
Silver, Total Recoverable (Ag)						
(May-Oct.)	0.0013	0.0026	0.93 µg/l	1.87 µg/l	once/month	composite
(Nov-April)	0.0025	0.0051	1.8 µg/l	3.6 µg/l	once/month	composite
Tin, Total Recoverable (Sn)	0.23	0.47	165.0 µg/l	335.0 µg/l	once/month	composite
Zinc, Total Recoverable (Zn)						
(May-Oct)	0.12	0.24	85.5 µg/l	171.6 µg/l	once/month	composite
(Nov-April)	0.23	0.47	166.0 µg/l	333.2 µg/l	once/month	composite
Cyanide, Total Recoverable (CN)					once/month	composite
(May-Oct)	0.008	1.016	5.8 µg/l	11.6 µg/l	once/month	composite
(Nov-April)	0.024	0.047	16.9 µg/l	33.9 µg/l	once/month	composite

Effluent Characteristics	Discharge Limitations				Monitoring Requirements	
	Mass (lbs/day, unless Otherwise specified)		Concentration (mg/l, unless Otherwise specified)		Frequency	Sample Type
	Monthly Avg.	Daily Max.	Monthly Avg.	Daily Max.		
Bis (2-ethylhexyl) phthalate	0.14	0.30	0.101	0.215	once/month	composite
Butylbenzyl phthalate	0.12	0.26	0.0887	0.188	once/month	composite
Carbazole	0.39	0.84	0.276	0.598	once/month	composite
n-Decane	0.61	1.33	0.437	0.948	once/month	composite
Fluoranthene	0.038	0.075	0.0268	0.0537	once/month	composite
n-Octadecane	0.42	0.83	0.302	0.589	once/month	composite
Radium-226 (dissolved)	N/A	N/A	Report pCi/l <sup>1</sup>	Report pCi/l <sup>1</sup>	once/quarter	grab
Strontium-90 (dissolved)	N/A	N/A	Report pCi/l <sup>1</sup>	Report pCi/l <sup>1</sup>	once/quarter	grab
Beta radiation (gross)	N/A	N/A	Report pCi/l <sup>1</sup>	Report pCi/l <sup>1</sup>	once/quarter	grab
pH	N/A	N/A	Minimum 6.0 s.u.	Maximum 9.0 s.u.	daily	grab
Chronic WET Testing <sup>2</sup>	N/A	N/A	Report			
Pimephales promelas (Chronic) Pass/Fail Lethality (7-day NOEC) TLP6C Pass/Fail Growth (7-day NOEC) TGP6C Survival (7-day NOEC) TOP6C Coefficient of Variation (Growth) TQP6C Growth (7-day NOEC) TPP6C			7-Day Average Report (Pass=0/Fail=1) Report (Pass=0/Fail=1) Report % Report %		bi-monthly bi-monthly bi-monthly bi-monthly	24-hr composite
Ceriodaphnia dubia (Chronic) Pass/Fail Lethality (7-day NOEC) TLP3B Pass/Fail Reproduction (7-day NOEC) TGP3B Survival (7-day NOEC) TOP3B Coefficient of Variation (reproduction) TQP3B Reproduction (7-day NOEC) TPP3B			7-Day Average Report (Pass=0/Fail=1) Report (Pass=0/Fail=1) Report % Report %		bi-monthly bi-monthly bi-monthly bi-monthly	24-hr composite

<sup>1</sup> pCi/liter

<sup>2</sup> See Condition No. 5 of Part II (WET Testing Requirement). There shall be no discharge of distinctly visible solids, scum, or foam of a persistent nature, nor shall there be any formation of slime, bottom deposits, or sludge banks. There shall be no visible sheen as defined in Part IV of this permit. Samples and measurements taken as required herein shall be representative of the volume and nature of the monitored discharge during the entire monitoring period. Samples shall be taken after final treatment at the outfall.

Table 1-A-1 Continued- Effluent Limitations and Monitoring Requirements. Source: After USEPA

The Southwestern Energy flow diagram is below.

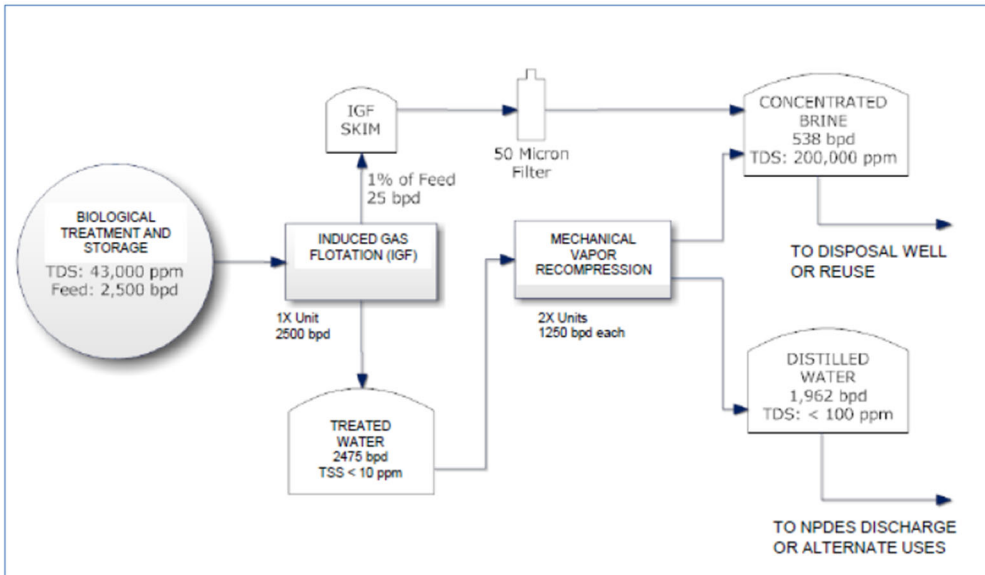

Wyoming's Short Form C includes their criteria for produced water quality for discharge.

[Wyoming Discharge Criteria](#)

TABLE 2

PARAMETER	REQUIRED DETECTION LIMIT and Required Units	STANDARD OR LIMIT*	SAMPLE RESULTS (Also submit lab results with application)
Aluminum, Dissolved	50 ug/L	750 ug/L	
Arsenic, Total	1 ug/L	150 ug/L	
Barium, Total ( <i>New Facilities Only</i> )	100 µg/L	2000 ug/L	
Boron, Dissolved ( <i>New Facilities Only</i> )	100 ug/L	5000 ug/L	
Cadmium, Dissolved	5 ug/L	0.25 ug/L (hardness dependent)	
Calcium, Dissolved	50 ug/L, report as mg/L		
Chloride – Technology Based	5 mg/L	2000 mg/L	
Chloride, For Class 2A and 2B Waters	5 mg/L	230 mg/L	
Chromium, Total	1ug/L	74.1 ug/L (hardness dependent)	
Copper, Dissolved	10 ug/L	9 ug/L (hardness dependent)	
Fluoride, Dissolved ( <i>New Facilities Only</i> )	100 ug/L	4,000 ug/L	
Hardness (CaCO <sub>3</sub> ) mg/L	10 mg/L as CaCO <sub>3</sub>	(for metals analyses)	
Iron, Dissolved	50 ug/L	1000 ug/L	
Iron, Dissolved, for Class 2A and 2AB	50 ug/L	300 ug/L	
Lead, Dissolved	2 ug/L	2.5 ug/L (hardness dependent)	
Magnesium, Dissolved	100 ug/L, report as mg/L		
Manganese, Dissolved	50 ug/L	1462 ug/L (hardness dependent)	
Manganese, Dissolved, for Class 2A and 2AB	50 ug/L	50 ug/L	
Mercury, Dissolved	1 ug/L	0.77 ug/L	
Molybdenum, Dissolved ( <i>New Facilities Only</i> )	100 ug/L	300 ug/L	
Nickel, Dissolved	10 ug/L	52 ug/L (hardness dependent)	
Oil and Grease	5 mg/L	10 mg/L	
pH	0.1 pH unit	6.5-9.0 s.u.	
Radium 226, Total	0.2 pCi/L	5 or 60 pCi/L	
Radium 228, Total **	0.2 pCi/L	5 pCi/L	
Selenium, Total	5 ug/L	5 ug/L	
Silver, Dissolved	3 ug/L	3.4 ug/L (hardness dependent)	
Sodium Adsorption Ratio	Calculated as unadjusted ratio		
Sodium, Dissolved	100 ug/L, report as mg/L		
Specific Conductance	5 micromhos/cm	7500 micromhos/cm	
Sulfates	10 mg/L	3000 mg/L	
Sulfide-Hydrogen Sulfide (S <sup>2-</sup> , HS <sup>-</sup> )	0.1 mg/L	2 ug/L	
Total Dissolved Solids	10 mg/L	5000 mg/L	
Total Petroleum Hydrocarbons	1 mg/L		
Zinc, Dissolved	50 ug/L	118.1 ug/L (hardness dependent)	

\*The values listed in the Standard or Limit column are associated with water quality standards (Chapter 1 of Wyoming Water Quality Rules and Regulations) or technology-based effluent limits (Chapter 2 of Wyoming Water Quality Rules and Regulations).

\*\*This parameter is only required for those discharges located within one stream mile of a class 2 water.

## Components of Produced Water – Lacking standards or Toxicity Testing

The Environmental Defense Fund (EDF) has had a cautious position about using treated produced water outside of the oilfield. EDF has spoken at industry conferences and written papers about the risks of components of produced water that have either not been consistently measured or that their toxicity has not been studied sufficiently. As part of a January, 2020 paper, EDF and university authors found 1198 chemicals in produced water and conclude that 86% of the chemicals lack toxicity data to complete a risk assessment in the US. The authors suggest a prioritized list that should be studied first.



[EDF paper](#)

A new Colorado State University study suggests that Oil and gas wastewater used for irrigation may suppress plant immune systems. The team led by Professor Thomas Borch of the Department of Soil and Crop Sciences conducted a greenhouse study using produced water from oil and gas extraction to irrigate common wheat crops. Their study, published in [Environmental Science and Technology Letters](#), showed that these crops had weakened immune systems, leading to the question of whether using such wastewater for irrigation would leave crop systems more vulnerable to bacterial and fungal pathogens.

## 5.0 Freshwater Quality Currently Used

### 5.1 Quality of groundwater currently

Particularly for agriculture, what is the quality of the groundwater they are using currently (MD you provided great risk-based limits for chemicals of interest for ag reuse, it would be interesting to compare that and water quality to what they're using now).

The Environmental Impact assessment by the New Mexico Office of the State Engineer shows the water quality in conductance at various points along the system. Upstream of Malaga, the conductance of about 4,000 mS/cm equates to a TDS of approximately 3,000 mg/L. Further downstream at Red Bluff, the conductance averages about 10,400 mS/cm equating to TDS of about 7,500 mg/L. [Carlsbad 2006 Water Quality](#)

A recent paper performed a detailed study of Pecos River water quality based on samples taken in 2015. Reach C (chart below) is the area in Eddy County that includes the Carlsbad Irrigation District. According to measurements made for Southwest Salt from 2010 to 2013, before the pumping of saline groundwater at the Southwest Salt plant began, the salinity of groundwater at Malaga Bend was greater than 6,700 mg/L; since 2013 the salinity has been averaging about 4,500 mg/L (Suzy Valentine, TCEQ, written commun., 2018).

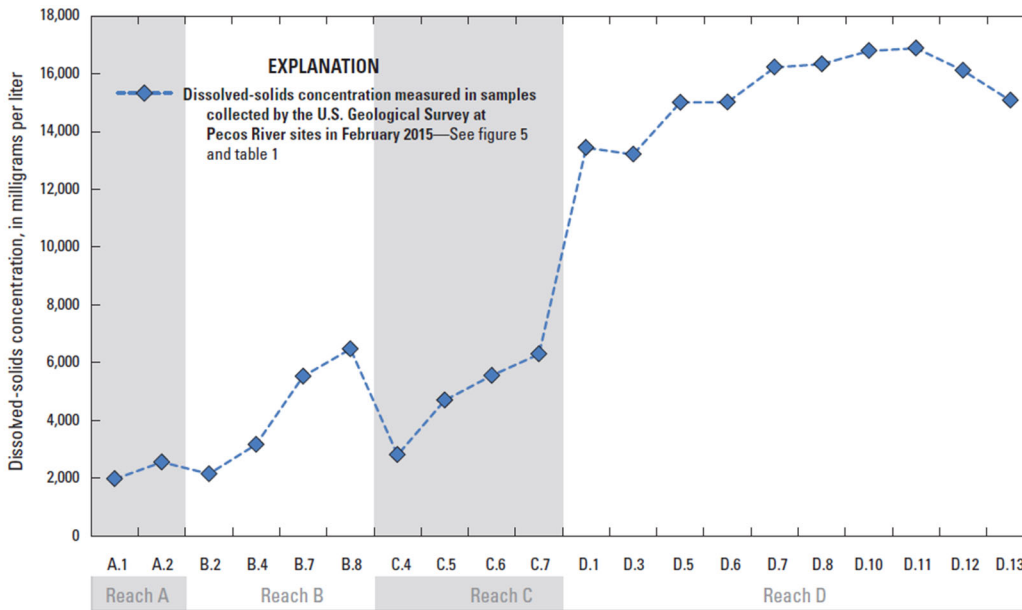

Site identifier (table 1)

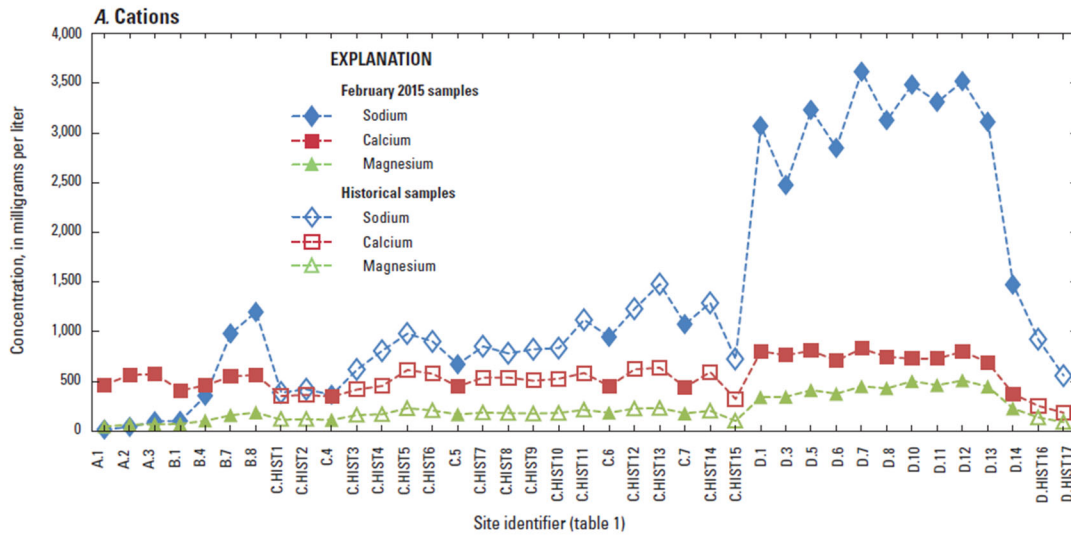

**Table 6.** Selected water-quality data including quality-control data from sites sampled by the U.S. Geological Survey in February 2015 in the Pecos River Basin, New Mexico and Texas.—Continued

[USGS, U.S. Geological Survey; deg C, degree Celsius; mg/L, milligram per liter; std, standard;  $\mu\text{S}/\text{cm}$ , microsiemens per centimeter; n/a, not collected; <, less than; BLM, Bureau of Land Management; TRIB, tributary; MRK, Farm to Market 1053;  $\text{CaCO}_3$ , calcium carbonate;  $\text{SiO}_2$ , silica; H, hydrogen; O, oxygen; Sr, strontium; per mil, a unit expressing the ratio of stable-isotope abundances of an element in a sample to those of a standard material. Sites at which quality-control data were collected are shown in blue font]

USGS station number	Site identifier (figs. 6, 7, 8, 9)	Sample date	Dissolved solids, dried at 180 deg C (mg/L)	Dissolved solids load (tons per day)	Calcium (mg/L)	Magnesium (mg/L)	Potassium (mg/L)	Sodium (mg/L)	Alkalinity (mg/L as $\text{CaCO}_3$ )	Bicarbonate (mg/L)	Bromide (mg/L)	Carbonate (mg/L)	Chloride (mg/L)
08382650	A.1	2/22/2015	1,980	9.02	464	46	1.7	16.4	153	185	<0.15	0.6	9
08382650	A.1	2/22/2015	n/a	n/a	470	47	1.7	17.5	151	182	<0.15	0.6	9
345701104422710	A.2	2/22/2015	2,560	20.5	566	67	1.9	42.5	149	181	<0.15	0.6	42
345701104422710	A.2	2/22/2015	<20	n/a	<0.022	<0.011	<0.03	<0.06	n/a	n/a	<0.03	n/a	<0.02
08385522	B.2	2/25/2015	2,150	201	410	72	3.1	103	155	187	<0.15	1.2	106
08386000	B.4	2/23/2015	3,170	249	461	105	3.9	356	114	137	<0.6	0.9	517
08394033	B.7	2/24/2015	5,530	971	551	161	5.7	982	156	187	<0.75	1.2	1,560
08396500	B.8	2/24/2015	6,470	1,276	566	188	8.2	1,200	155	185	<0.75	1.8	2,060
08405200	C.4	2/24/2015	2,810	223	346	113	5	366	184	220	0.33	2	602
08406500	C.5	2/26/2015	4,700	890	450	169	8.4	673	160	192	<1.5	1.5	1,130
08407000	C.6	2/25/2015	5,550	972	452	185	22.5	948	160	190	<1.5	2.8	1,240
08407500	C.7	2/25/2015	6,300	1,212	441	179	25.9	1,080	156	186	<1.5	2.4	1,760

[USGS paper on Pecos River quality](#)

## 5.2 PW blending

Any PW blending happening currently as is the case in CA? (Don't think so, but if true would be interesting) If so, at what levels. If not, look to CA blending regulations/practices

The table below gives analyses of fresh water compared to the NMWQCC drinking water standard. Data are from [4].



**Table 2-11. Sampled Water Quality Parameters Against NMWQCC Drinking Water Standards**

Parameter	NMWQCC Standard	North HPA	Central North HPA	South HPA and WIPP	Capitan Reef
pH (pH units)	6 to 9	7.07 - 7.97	7.53 - 7.97	6.18 - 8.59	8.08 - 8.86
Specific Conductance (µmhos/cm)	--	1000 - 3905	1300 - 83000	600 - 270000	2770 - 174500
Total Dissolved Solids (TDS)	1000	331 - 3550	869 - 43000	322 - 330000	1951 - 141875
Calcium (Ca2+)	--	0.73 - 590	2.6 - 920	0.7 - 1900	1.4 - 5902
Magnesium (Mg2+)	--	23 - 200	44 - 1492	2.10 - 10000	82.26 - 1420
Sodium (Na+)	--	18 - 262	92.58 - 12000	26 - 95000	225 - 46700
Potassium (K+)	--	0 - 30	4 - 1136	0 - 21000	6.58 - 3352
Chloride (Cl-)	250	16 - 1000	97 - 21000	11 - 190000	388.80 - 82602.1
Alkalinity (CaCO3)	--	139 - 312	19.9 - 181.2	23 - 297.10	18.53 - 250.10
Bicarbonate (HCO3-)	--	139 - 312	19.8 - 181.2	39.72 - 297.10	18.74 - 249.27
Carbonate (CO3-)	--	0 - <2	0 - <2	0 - 16.08	0 - 0.83
Sulfate (SO42-)	600	0 - 1900	306.71 - 6400	0 - 15000	0 - 1975.67
Fluoride (F-)	1.6	0 - 1.3	0.82 - 2.60	0.00 - 3.63	0.09 - 0.52
Nitrite (NO2)	10	0 - 6.27	0 - 8.8	0.00 - 20.08	0.05 - 7.60
Nitrate (NO3)	10	0 - 10	2.6 - 8.8	0 - 19	0.04 - 7.60
Silver (Ag)	0.05	--	--	--	0
Aluminum (Al)	5	--	0.18	0 - 4.06	--
Arsenic (As)	0.1	0.02 - 0.06	0.03 - 0.32	0 - 0.29	0.10
Barium (Ba)	1	0.01 - 0.13	0.01 - 0.03	0 - 0.1	0.02 - 0.25
Bromide (Br)	--	0 - 7.8	0.28 - 12.00	0 - 1400	0.3 - 12.73
Cadmium (Cd)	0.01	--	--	--	--
Copper (Cu)	1	0.02	0.03	0.06 - 0.37	--
Iron (Fe)	1	3.34	0.04	0.01 - 1.62	3.41
Lithium (Li)	--	0.14 - 1.70	0.140 - 1.695	0.05 - 0.85	0.04 - 4.49
Manganese (Mn)	0.2	0 - 0.06	0 - 0.20	0 - 0.06	0 - 7.61
Nickel (Ni)	0.2	--	0 - 0.02	0 - 0.01	0.01
Lead (Pb)	0.05	0.04	--	0.02 - 0.06	--
Silicon (Si)	--	2.67 - 18.38	1.9 - 23.4	4.91 - 47.0	0 - 7.10
Strontium (Sr2+)	--	0.63 - 8.47	2.73 - 13.75	0.05 - 32.0	2.52 - 104.8
Vanadium (V)	--	--	0.01 - 0.03	0 - 0.1	--

Source: Lowry et al. 2018.

Notes: Units are milligrams per liter (mg/L) unless otherwise noted. "--" = not applicable or not detected. Values rounded to two decimal places.

## 6.0 Source and Demand Geography

How do the agricultural users currently get their water? By pipeline?

Midstream locations and demand locations are highlighted in this section, with a focus in New Mexico. It is assumed that the highest demand for Zwitterco/desalination technology will be in New Mexico.

The tables below are from [4].

**Table 3-6. 2015 State of New Mexico Water Use Associated with Oil and Gas Development**

County	Surface Water	Groundwater	Total	% of Total
Bernalillo	0	7	7	0%
Chaves	0	84	84	2%
Eddy	0	2,635	2,635	65%
Lea	0	1,275	1,275	32%
Rio Arriba	0	0	0	0%
Sandoval	0	0	0	0%
San Juan	30	0	30	0.7%
Sierra	0	1	1	0%
State total	30	4,002	4,032	100%

Source: NMOSE 2019

**Table 3-7. State of New Mexico Water Use by Category (AF)**

Category	Surface Water				Groundwater				Total Water				Rio Arriba Total % of NM
	Fresh	Saline	Total Surface Water	% of Total Water	Fresh	Saline	Total Groundwater	% of Total Water	Fresh	Saline	Total Water	% of Total Water	
Aquaculture	6,109	0	6,109	23%	20,929	0	20,929	77%	27,039	0	27,039	1%	13%
Domestic	0	0	0	0%	27,621	0	27,621	100%	27,621	-	27,621	1%	5%
Industrial	0	0	0	0%	3,811	0	3,811	100%	3,811	0	3,811	0%	0%
Irrigation	1,485,112	0	1,485,112	56%	1,175,312	0	1,175,312	44%	2,660,424	0	2,660,424	82%	4%
Livestock	2,522	0	2,522	7%	33,372	0	33,372	93%	35,894	0	35,894	1%	1%
Mining†	19,550	0	19,550	12%	44,111	100,240	144,351	88%	63,662	100,240	163,901	5%	1%
Public Water Supply	87,752	0	87,752	30%	205,715	0	205,715	70%	293,467	0	293,467	9%	1%
Thermoelectric Power	30,637	0	30,637	82%	6,872	0	6,872	18%	37,509	-	37,509	1%	0%
<b>State-wide Totals</b>	<b>1,631,683</b>	<b>0</b>	<b>1,631,683</b>	<b>50%</b>	<b>1,517,744</b>	<b>100,240</b>	<b>1,617,984</b>	<b>50%</b>	<b>3,149,427</b>	<b>100,240</b>	<b>3,249,667</b>	<b>100%</b>	<b>4%</b>

Source: Source: Dieter et al. 2018; updated with additional information provided to the BLM from the NMOSE regarding water use of the Navajo Power Plant (BLM 2019a).

New Mexico, as a state, uses 31% surface water and 69% groundwater, per the 2015 NM State Engineer's report on water use. The table below breaks down the water use by category. Irrigation for agriculture uses 76% of the state water use, followed by public water use (9%) and evaporation from reservoirs (7%).

The primary use of irrigation water state-wide is for the production of alfalfa and pecans. Cattle (Dairy and non-dairy) make up 90% of the state's livestock population.

The majority of the unconventional produced water is produced in Eddy and Lea counties that are in the Pecos and Texas Gulf River Basins.

In the Pecos River Basin, groundwater represented 59% of the water withdrawals and groundwater was 100% of withdrawals in the Texas Gulf River Basin.

[NM State Engineer Water use 2015](#)

## 7.0 Demand Quantity

Included in this section are tabulations of the quantities of water being used for various activities in South East New Mexico. Also included here is an estimate of what the demand quantities could be if a new source of high-quality water was available to the end users. The Demand Quantities given in this section are linked here to the Demand Geographies in section 5. The seasonality of water demand is included. Activities such as agriculture, for example, will have high demand in certain months and low demand in others. The amount of water produced by the oil and gas operators will

not be strongly dependent on rainfall or seasonality. Thus, it will be a challenge to figure out how to load level a non-seasonal supply provided by the oil and gas operators against a highly seasonal demand driven by agricultural activities. One of the more useful sources of information on demand quantity of water is the Bureau of Land Management report of the New Mexico State BLM Office, Santa Fe [4]. The report provides detailed information on the quantities of groundwater and surface water being consumed for various applications. Agriculture is the largest demand activity. But the report focuses on oil and gas activity because the water demand by the oil and gas industry has grown so fast in the last decade or so. Due to this focus on oil and gas the BLM report focuses on two general regions, the North West and the South East of the state. The South East comprises the Delaware Basin of the Permian. The North West part of the state has oil and gas activity as well. The South East portion of the state is covered by the following groupings of counties and BLM Field Offices:

- 1) Pecos District Tr-County Area (Lea, Eddy, Chavez)
- 2) Farmington Field Office
- 3) Rio Puerco Field Office

These regions are a combination of field offices and counties. The Pecos District Tri-County Area covers three counties: Lea, Eddy, and Chavez. The area of these three counties defines the Pecos District. This area falls into the Carlsbad Field Office and a portion of the south of the Roswell Field Office. The other two locations covered in the NM BLM report are defined by the Farmington Field Office and the Rio Puerco Field office. These are in the North West portion of the state. Several counties are found in this area.

Field office locations are shown on the map below.

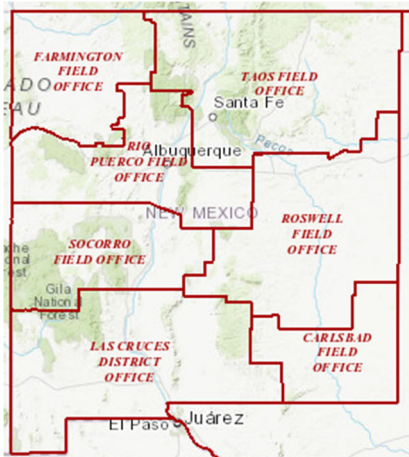

The following map provides:

- 1) various counties (brown lines)
- 2) main cities
- 3) main rivers (light blue lines)
- 4) river basin areas (dark blue lines).

As mentioned, the report covers the Delaware Basin through its inclusion of the three counties: Chaves, Eddy, and Lea.

## Major River Basins in New Mexico



The next five tables provide data on the water usage for three counties in NM, and the total water usage in the state. The water usage is broken down by usage category. The discussion of this data is based on reference [4]. The data for these tabulations is originally from [7].

**Table 2-1. Lea County 2015 Water Use by Category (AF)**

Category	Surface Water				Groundwater				Total Withdrawals					
	AF Fresh	Saline	Total	% of Total Use	Fresh	Saline	Total Groundwater	% of Total Use	Fresh	% of Total Use	Saline	% of Total Use	Total	% of Total Use
Public Water Supply	0	0	0	0%	11,423	0	11,423	100%	11,423	100%	0	0%	11,423	4%
Industrial	0	0	0	0%	78	0	78	100%	78	100%	0	0%	78	0%
Irrigation	0	0	0	0%	166,099	0	166,099	100%	166,099	100%	0	0%	166,099	62%
Livestock	56	0	56	2%	2,870	0	2,870	98%	2,926	100%	0	0%	2,926	1%
Aquaculture	0	0	0	0%	0	0	0	0%	0	0%	0	0%	0	0%
Mining	0	0	0	0%	325	81,642	81,968	100%	325	0.4%	81,642	99.6%	81,968	31%
Thermoelectric Power	0	0	0	0%	1,827	0	1,827	100%	1,827	100%	0	0%	1,827	1%
Domestic	0	0	0	0%	1,513	0	1,513	100%	1,513	100%	0	0%	1,513	1%
<b>County Totals</b>	<b>56</b>	<b>0</b>	<b>56</b>	<b>0%</b>	<b>184,136</b>	<b>81,642</b>	<b>265,778</b>	<b>100%</b>	<b>184,192</b>	<b>69%</b>	<b>81,642</b>	<b>31%</b>	<b>265,834</b>	<b>100%</b>

Source: Dieter et al. 2018.  
Note: AF is acre-feet

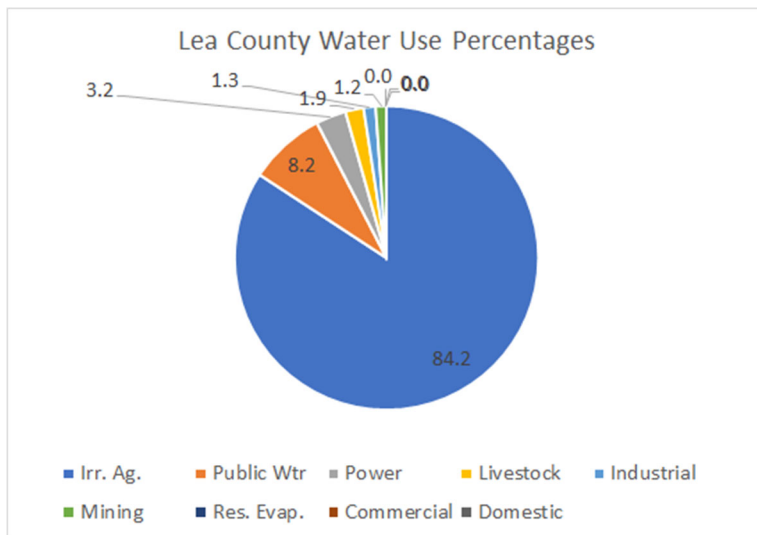

**Table 2-2. Eddy County 2015 Water Use by Category (AF)**

Category	Surface Water				Groundwater				Total Withdrawals					
	AF Fresh	AF Saline	AF Total	% of Total Use	AF Fresh	AF Saline	AF Total	% of Total Use	AF Fresh	% of Total Use	AF Saline	% of Total Use	AF Total	% of Total Use
Public Water Supply	0	0	0	0%	15,077	0	15,077	100%	15,077	100%	0	0%	15,077	8%
Industrial	0	0	0	0%	1,043	0	1,043	100%	1,043	100%	0	0%	1,043	1%
Irrigation	64,054	0	64,054	42%	89,994	0	89,994	58%	154,048	100%	0	0%	154,048	84%
Livestock	34	0	34	3%	1,289	0	1,289	97%	1,323	100%	0	0%	1,323	1%
Aquaculture	0	0	0	0%	0	0	0	0%	0	0%	0	0%	0	0%
Mining	0	0	0	0%	1,169	10,993	12,162	100%	1,169	10%	10,993	90%	12,162	8%
Thermoelectric Power	0	0	0	0%	0	0	0	0%	0	0%	0	0%	0	0%
Domestic	0	0	0	0%	258	0	258	100%	258	100%	0	0%	258	0%
<b>County Totals</b>	<b>64,088</b>	<b>0</b>	<b>64,088</b>	<b>35%</b>	<b>108,830</b>	<b>10,993</b>	<b>119,823</b>	<b>65%</b>	<b>172,918</b>	<b>94%</b>	<b>10,993</b>	<b>6%</b>	<b>183,910</b>	<b>100%</b>

Source: Dieter et al. 2018. Note: AF is acre-feet

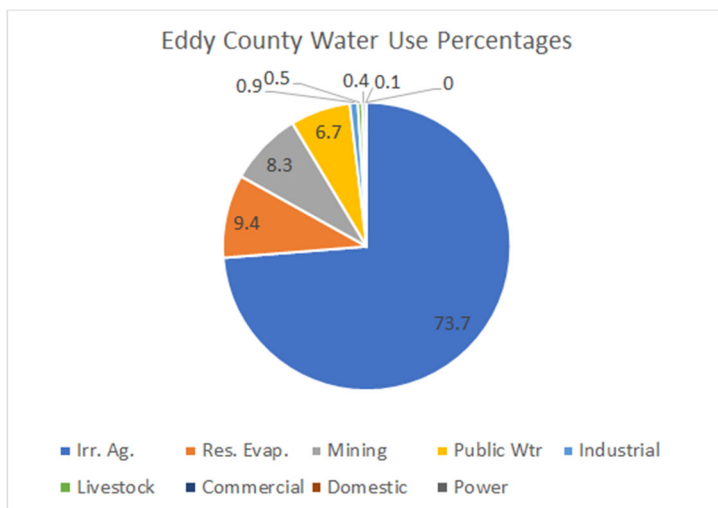

**Table 2-3. Chavez County 2015 Water Use by Category (AF)**

Category	Surface Water				Groundwater				Total Withdrawals					
	AF Fresh	AF Saline	AF Total	% of Total Use	AF Fresh	AF Saline	AF Total	% of Total Use	AF Fresh	% of Total Use	AF Saline	% of Total Use	AF Total	% of Total Use
Public Water Supply	0	0	0	0%	12,970	0	12,970	100%	12,970	100%	0	0%	12,970	8%
Industrial	0	0	0	0%	0	0	0	0%	0	0%	0	0%	0	0%
Irrigation	9,854	0	9,854	7%	136,784	0	136,784	93%	146,638	100%	0	0%	146,638	86%
Livestock	224	0	224	3%	6,378	0	6,378	97%	6,603	100%	0	0%	6,603	4%
Aquaculture	0	0	0	0%	1,782	0	1,782	100%	1,782	100%	0	0%	1,782	1%
Mining	0	0	0	0%	78	1,592	1,670	100%	78	5%	1,592	95%	1,670	1%
Thermoelectric Power	0	0	0	0%	0	0	0	0%	0	0%	0	0%	0	0%
Domestic	0	0	0	0%	1,009	0	1,009	100%	1,009	100%	0	0%	1,009	1%
<b>County Totals</b>	<b>10,078</b>	<b>0</b>	<b>10,078</b>	<b>6%</b>	<b>159,003</b>	<b>1,592</b>	<b>160,594</b>	<b>94%</b>	<b>169,080</b>	<b>99%</b>	<b>1,592</b>	<b>1%</b>	<b>170,672</b>	<b>100%</b>

Source: Dieter et al. 2018.

**Table 2-4. Pecos District Tri-County Area 2015 Water Use by Category (AF)**

Category	Surface Water				Groundwater				Total Withdrawals					
	AF Fresh	AF Saline	AF Total	% of Total Use	AF Fresh	AF Saline	AF Total	% of Total Use	AF Fresh	% of Total Use	AF Saline	% of Total Use	AF Total	% of Total Use
Public Water Supply	-	-	-	0%	39,470	-	39,470	100%	39,470	100%	0	0%	39,470	6%
Industrial	-	-	-	0%	1,121	-	1,121	100%	1,121	100%	0	0%	1,121	0%
Irrigation	73,908	-	73,908	16%	392,877	-	392,877	84%	466,784	100%	0	0%	466,784	75%
Livestock	314	-	314	3%	10,537	-	10,537	97%	10,851	100%	0	0%	10,851	2%
Aquaculture	-	-	-	0%	1,782	-	1,782	100%	1,782	100%	0	0%	1,782	0%
Mining	-	-	-	0%	1,573	94,227	95,800	100%	1,573	1%	24,227	99%	95,800	15%
Thermoelectric Power	-	-	-	0%	1,827	-	1,827	100%	1,827	100%	0	0%	1,827	0%
Domestic	-	-	-	0%	2,780	-	2,780	100%	2,780	100%	0	0%	2,780	0%
<b>District Totals</b>	<b>74,221</b>	<b>-</b>	<b>74,221</b>	<b>12%</b>	<b>451,968</b>	<b>24,227</b>	<b>546,195</b>	<b>88%</b>	<b>526,195</b>	<b>85%</b>	<b>24,227</b>	<b>15%</b>	<b>620,416</b>	<b>100%</b>

Source: Dieter et al. 2018. Note: AF is acre-feet.

**Table 2-6. 2015 State of New Mexico Water Use Associated with Oil and Gas Development (AF)**

County	Surface Water	Groundwater	Total	% of Total
Bernalillo	0	7	7	0%
Chaves	0	84	84	2%
Eddy	0	2,635	2,635	65%
Lea	0	1,275	1,275	32%
San Juan	30	0	30	1%
Sierra	0	1	1	0%
<b>State Total</b>	<b>30</b>	<b>4,002</b>	<b>4,032</b>	<b>100%</b>

Source: NMOSE 2019.

Note: AF is acre-feet.

## 8.0 Conclusions

The objective of this appendix is to evaluate the potential for beneficial reuse (use outside of well completions operations) of produced water generated in shale development. Several options were evaluated in depth. The main conclusion is that shale produced water salinity is far too high for it to be attractive for essentially all applications in West Texas and Southeast New Mexico. Despite the fact that these regions are arid, suffer from frequent water

shortages, and struggle to maintain adequate groundwater and river levels much lower salinity is required for produced water to have any value. The main conclusion of this study is that demand for low salinity is very high while demand for high salinity water is essentially confined to shale completions operations. This conclusion is incorporated in the Techno-Economic Analysis that is developed in the main body of the project report.

## References

- 1) R. Perry, R. Bosch, "Variations in water chemistry in high volume fracturing operations," Presentation given to the Society of Petroleum Engineers, Dallas-Fort Worth (2012).
- 2) T. Hayes, D. Arthur, "Overview of emerging produced water treatment technologies," paper presented at the 11th Annual International Petroleum Environmental Conference, Albuquerque, NM, October (2004).
- 3) R. Lee, R. Seright, M. Hightower, A. Sattler, M. Cather, B. McPherson, L. Wrotenbery, D. Martin, M. Whitworth, "Strategies for produced water handling in New Mexico," Ground Water Protection Council Produced Water Conference (2002).
- 4) U.S. Department of the Interior, Bureau of Land Management, New Mexico State Office, Santa Fe (2019).
- 5) C.A. Dieter, M.A. Maupin, R.R. Caldwell, M.A. Harris, T.I. Ivanhnenko, J.K. Lovelace, N.L. Barber, K.S. Linsey, "Estimated use of water in the United States in 2015: U.S. Geological Circular 1441 (2018). Report and database available at: <https://>
- 6) M.A. Engle, F.R. Reyes, M.S. Varonka, W.H. Orem, L. Ma, A.J. Ianno, T.M. Schell, P. Xu, K.C. Carroll, "Geochemistry of formation waters from the Wolfcamp and Cline shales: Insights into brine origin, reservoir connectivity, and fluid flow in the Permian Basin, USA," *Chem. Geology*, v. 425, p. 76 (2016).
- 7) M.S. Blondes, K.D. Gans, J.J. Thordsen, M.E. Reidy, B. Thomas, M.A. Engle, Y.K. Kharaka, E.L. Rowan. "US Geological Survey National Produced Waters Geochemical Database v2. 3 (PROVISIONAL)." United States Geological Survey (2016).
- 8) L.T. Bryndzia, A.M. Hows, R.J. Day-Stirrat, A. Nikitin, O. Huvaz, "Sources of produced water in the Permian Delaware Basin, West Texas: A geochemical analysis," URTEC, paper number 102, presented at the Unconventional Resources Technology Conference, Denver (2019).
- 9) B.K. Chaudhary, S.E. Willman, K.C. Carroll, "Spatial variability and geochemistry of produced water in Southeastern New Mexico, USA," Report prepared for the New Mexico Water Resources Research Institute (2016).
- 10) Dow Liquid Separations. FILMTEC Reverse Osmosis Membranes Technical Manual.
- 11) H. Ettouney, Thermal Desalination, chapter 2 of Seawater Desalination, ed: A. Cipollina (2009)
- 12) C. Fritzmann, J. Lowenberg, T. Wintgens, T. Melin, "State-of-the-art of reverse osmosis desalination," *Desal.*, v. 216, p. 1 (2007).
- 13) L. Henthorne, "Trends in pretreatment for seawater reverse osmosis," *Water Conditioning and Purification*, (2010).
- 14) M. Cakmakci, N. Kayaalp, I. Koyuncu, "Desalination of produced water from an oil production field by membrane processes," *Desal.*, v. 222, p. 176 (2008).
- 15) L.M. Camacho, L. Dumeé, J. Zhang, J.-d. Li, M. Duke, J. Gomez, S. Gray, "Advances in membrane distillation for water desalination and purification applications," *Water*, v. 5, p. 94 (2013).
- 16) M. Padaki, R.S. Murali, M.S. Abdullah, N. Misdan, A. Moslehyani, M.A. Kassim, N. Hilal, A.F. Ismail, "Membrane technology enhancement in oil-water separation. A review," *Desal.*, v. 357, p. 197 (2015).
- 17) E.T. Igunnu, G.Z. Chen, "Produced water treatment technologies," *Int. J. Low-Carbon Technologies*, v. 9, p. 157 (2014).
- 18) [usclimate.com](http://usclimate.com)
- 19) [USGS SIR 2017-5040](https://pubs.usgs.gov/circ/c1441/). (Public domain)
- 20) T. Bilstad, E. Espedal, "Membrane separation of produced water," *Water Sci. Tech.*, v. 34, p. 239, (1996).
- 21) M. Cheryan, N. Rajagopalan, "Membrane processing of oily streams. Wastewater treatment and waste reduction," *J. Mem. Sci.*, v. 151, p. 13 (1998).

- 22) R. Schwantes, K. Chavan, D. Winter, C. Felsmann, J. Pfafferott, "Techno-economic comparison of membrane distillation and MVC in a zero liquid discharge application," *Desal.*, v. 428, p. 50 (2018).
- 23) P. Prakash, "Thermal desalination of produced water in heavy oil assets," paper presented at the Produced Water Society, Houston Feb (2020). Originally published as: D. Singh, P. Prakash, K.K. Sirkar, "Deoiled produced water treatment using direct-contact membrane distillation," *I&EC Res.*, v. 52, p. 13439 (2013).
- 24) J.H. Hanemaaijer, "Memstill - low cost membrane distillation technology for seawater desalination," *Desal.*, v. 168, p. 355 (2004).
- 25) C. Dotremont, B. Kregersman, R. Sih, K. Cheong Lai, K. Koh, and H. Seah. "Seawater desalination with memstill technology-a sustainable solution for the industry." *Water Practice and Technology* 5, no. 2 (2010).
- 26) G.M. dos Ramos, "Membrane separation processes applied to oily water treatment," Third Int. Seminar on Oilfield Water Management, Rio de Janeiro (Jun 2010).
- 27) J.M. Lee, T. Frankiewicz, "Treatment of produced water with an ultrafiltration (UF) membrane - a field trial," SPE - 95735, paper presented at the SPE ATCE, Dallas (2005).
- 28) L.D. Tijing, Y.C. Woo, J.-S. Choi, S. Lee, S.-H. Kim, H.K. Shon, "Fouling and its control in membrane distillation - A review," *J. Mem. Sci.*, accepted for publication (2014).
- 29) P. Dydo, M. Turek, J. Ciba, K. Wandachowicz, J. Misztal, "The nucleation kinetic aspects of gypsum nanofiltration membrane scaling," *Desal.*, v. 164, p. 41 (2004).
- 30) J. Swaminathan, H.W. Chung, D.M. Warsinger, J.H. Lienhard, "Energy efficiency of membrane distillation up to high salinity: evaluating critical system size and optimal membrane thickness," *App. Energy*. v. 211, p. 715 (2018).
- 31) J.H. Hanemaaijer, J.v. Medevoort, A.E. Jansen, C. Dotremont, E.v. Sonsbeek, T. Yuan, L.D. Ryck, "Memstill membrane distillation - a future desalination technology," *Desal.*, v. 199, p. 175 (2006)
- 32) R. Schwantes, L. Bauer, K. Chavan, D. Ducker, C. Felsmann, J. Pfafferott, "Air gap membrane distillation for hypersaline brine concentration: operational analysis of a full-scale module - New strategies for wetting mitigation," *Desal.*, v. 444, p. 13 (2018).
- 33) D.M. Warsinger, J. Swaminathan, E. Guillen-Burrieza, H.A. Arafat, J.H. Lienhard, "Scaling and fouling in membrane distillation for desalination applications: A review," *Desal.*, v. 356, p. 294 (2015).
- 34) A. Deshmukh, C. Boo, V. Karanikola, S. Lin, A.P. Straub, T. Tong, D.M. Marsinger, M. Elimelech, "Membrane distillation at the Water-Energy Nexus: limits, opportunities, challenges," *Energy & Env. Sci.* (2018).
- 35) Hydranautics Corp., "HYDRAcap MAX Technology. Solutions you need. Technologies you trust," Hydranautics presentation (2016).
- 36) GE Osmonics, "Produced Water Membrane Technology," presentation.
- 37) A.C. Hong, A.G. Fane, R.P. Burford, "The effects of intermittent permeate flow and crossflow on membrane coalescence of oil-in-water emulsions," *Desal.*, v. 144, p. 185 (2002).
- 38) A. Lawrence, "An evaluation of ultrafiltration and nanofiltration in deoiling produced water from a heavy oil production site," Wastewater Technology Centre, Burlington, Ontario, Canada (1995).
- 39) x
- 40) M.R. da Costa Marques, P.S.A. de Souza, M.M. Rigo, A.A. Carqueira, J.L. de Paiva, "Effects of untreated and treated oilfield-produced water on seed germination, seedling development, and biomass production of sunflower (*Helianthus annuus* L.)," *Env. Sci. Poll. Res. Int.*, published online (2015)
- 41) J.C. Niemeyer, L.O. Medici, B. Correa, D. Godoy, G. Ribeiro, S.d.O.F. Lima, F.B.d. Santo, D.F. de Carvalho, "Treated produced water in irrigation: Effects on soil fauna and aquatic organisms," *Chemoshpere*, v. 240, published online (2020).
- 42) E.N. Sappington, H.S. Rifal, "Low-frequency electromagnetic treatment of oilfield produced water for reuse in agriculture: effect on water quality, germination, and plant growth," *Env. Sci. Pollution Res.*, (2018).
- 43) P.S.A. de Souza, A.A. Cerqueira, M.M. Rigo, J.L. de Paiva, R.S.P. Couto, F. Mercon, D.V. Perez, M.R.C. Marques, "Oilfield water treatment by electrocoagulation-reverse osmosis for agricultural use: Effect on germination and early growth characteristics of sunflower," *Env. Tech.*, published online (2016).
- 44) A.C.M.A. de Meneses, O.B. Weber, L.A. Crisostomo, D.J. Andrade, "Biological soil attributes in oilseed crops irrigated with oilfield produced water in the semi-arid region" *Rev. Ciencia Agron.*, v. 48, p. 231 (2017).



- 45) A. Burkhardt, A. Gawde, C.L. Cantrell, V.D. Zheljzkov, "Effect of varying ratios of produced water and municipal water on soil characteristics, plant biomass, and secondary metabolites of *Artemisia annua* and *Panicum virgatum*," *Industrial Crops and Products*, v. 76, p. 987 (2015).
- 46) A. Burkhardt, A. Gawde, C.L. Cantrell, H.L. Baxter, B.L. Joyce, C.N. Stewart, V.D. Zheljzkov, "Effects of produced water on soil characteristics, plant biomass, and secondary metabolites," *J. Env. Quality*, v. 44, p. 1938 (2015).
- 47) N.E. Pica, K. Carlson, J.J. Steiner, R. Waskom, "Produced water reuse for irrigation of non-food biofuel crops: Effects on switchgrass and rapeseed germination, physiology and biomass yield," *Industrial Crops and Products*, v. 100, p. 65 (2017).
- 48) R.N.C. Ferreira, O.B. Weber, L.A. Crisostomo, "Produced water irrigation changes the soil mesofauna community in a semiarid agroecosystem," *Env. Monit. Assess.*, v. 187, p. 519 (2015).
- 49) A.F. Sousa, L.A. Crisostomo, L.A. Weber, O.B. Escobar, M.E.O. Escobar, T.S.D. Oliveira, "Nutrient content in sunflowers irrigated with oil exploration water," *Revista Caatinga*, v. 29, p. 94 (2016).
- 50) R.N.C. Ferreira, O.B. Weber, M.E. Correia, E.S. Benazzi-Ikeda, R.N. Scoriza, A.L. Mesquita, "Effects of wastewater from oil exploration on soil meso-fauna," *Bull. Env. Contaminant Toxicol*, v. 95, p. 777 (2015).
- 51) N. Yan, P. Marschner, W. Cao, C. Zuo, W. Qin, "Influence of salinity and water content on soil microorganisms," *Int. Soil Water Cons. Res.*, v. 3, p. 316 (2015).
- 52) R. Ayers, D.W. Westcot, "Water quality for agriculture," Food and Agriculture Organization (FAO) of the United Nations, Rome <http://www.fao.org/3/t0234e/T0234E00.htm#pre> (1985).
- 53) M. Burgos, G. Lebas, "Beneficial reuse of production water for irrigation," IPTC-18389, paper presented at the International Petroleum Technology Conference, Doha (2015).
- 54) B.G. Andrade, V.T. Andrade, B.R.S. Costa, J.C. Campos, M. Dezotti, "Distillation of oil field produced water for reuse on irrigation water: evaluation of pollutants removal and ecotoxicity," *J Water Reuse Desalination* (2011).
- 55) K. Lewis, J. Moore, "Agricultural reuse of treated produced water," Texas A&M PP presentation (2015).
- 56) US Environmental Protection Agency, "Guidelines for water reuse," EPA/600/R-12/618 (2012)
- 57) J.C. Campos, R.M.H. Borges, A.M.O. Filho, R. Nobrega, G.L. Sant' Anna, "Oilfield wastewater treatment by combined microfiltration and biological processes," *Water Res.*, v. 36, p. 95 (2002).
- 58) S. Munirasu, M.A. Haija, F. Banat, "Use of membrane technology for oil field and refinery produced water treatment – A review," *ICHEME Process Safety and Env Protection*, v. 100 (2016)