



PNNL ARENA Cable Motor Test Bed Update

S.W. Glass, L.S. Fifield, M. Prowant

June 2021



PNNL 31415

Summary:

A major focus of the Light Water Reactor Sustainability (LWRS) Cable Nondestructive Examination (NDE) 2021 research is to acquire new equipment and integrate it with existing NDE instruments for a cable motor test bed which has been dubbed the Accelerated and Real Time Experimental Nodal Analysis or “ARENA”. All the primary components have been received and are being staged in the 2410 Stevens building on PNNL’s Richland campus. Building modifications to support a plug-in 480VAC receptacle have been completed and details of the system operating procedure (SOP) are in review. The approved SOP is required before the system is energized but is expected before July 2021.

The ARENA system will support planned cable tests for 2021 and beyond that cannot conveniently be performed with on-site installations of cable test equipment including:

- NDE Tests including Frequency Domain Reflectometry (FDR), Time Domain Reflectometry (TDR), Tan Delta (TD) Impedance measurements, Low Frequency Dielectric Spectroscopy (DS) measurements, standard multi-meter resistance checks, withstand tests and other bulk and distributed tests from the instrument panel with and without motors connected.
- Online energized live wire tests using partial discharge instruments and LIVE-WIRE spread-spectrum TDR instruments.
- Cable tests with partially submerged cable segments (including ability to submerge live cable segments).
- Cable tests with partially or completely thermally aged segments (including ability to expose energized cable segments to thermal aging and use online monitoring instruments to monitor cable performance).
- Ability to introduce low resistance simulations of connector or splice faults to off-line and on-line instrument setups.

ARENA description

The system is shown in Figure 1 and consists of the following Table 1 components:

Table 1 ARENA cable motor test bed components and planned associated NDE instruments

Cable/Motor Test Bed	Available NDE Test /Analysis Instruments
480 VAC ½ HP 3-Phase Motor: ABB-M3538-1800-3/60/208-460v=TFC-56	COPPER MOUNTAIN TR1300/1 VNA to interface with LIRA Frequency-Domain Reflectometry (FDR) software
ABB EM5001A01SP Smart Sensor Kit for roll steel motor	AGILANT 4294A Precision Impedance Analyzer

<p>Test-Bed Panel including:</p> <ul style="list-style-type: none"> • 34x24x24 Instrument Cabinet • Input PDB with multiple taps for motor/test connections • Sprecher & Schuh KTA7 Motor Circuit Controller (MCC) <ul style="list-style-type: none"> • Ground Fault Therma Circuit • 300VA 480V circuit protection <ul style="list-style-type: none"> • Run/Fault Pilot switch • Start/Stop 2 position Selector 	HVD HVA28TD Tan Delta Test Unit
Hand/Off/Auto 3 position remote switch	LIRA: Wirescan LIRA Portable (FDR)
6-903-SH 14 AWG 3/C FR-EP 600V; FR-EPR/CPE Foil Shielded cable (for connection from cabinet to motor)	MOHR CT100HF Time-Domain Reflectometry (TDR)
6-903-G 14 AWG-3/C FR-EP 600V; FR-EPR/CPE Non-Shld 600V E-2 Alternate unshielded cable for connection from cabinet to motor	LiveWire Mantis Spread Spectrum Time-Domain Reflectometry (SSTDR)
Barrel water bath for environmental water exposure	Spectrano 100 Low Frequency Dielectric Spectroscopy Impedance Analyzer (Available after July 2021)
Furnace for cable exposure up to 300°C	ANSYS circuit and Finite Element Analysis Software
	COMSOL circuit and Finite Element Analysis Software
	MATLAB signal analysis simulation software

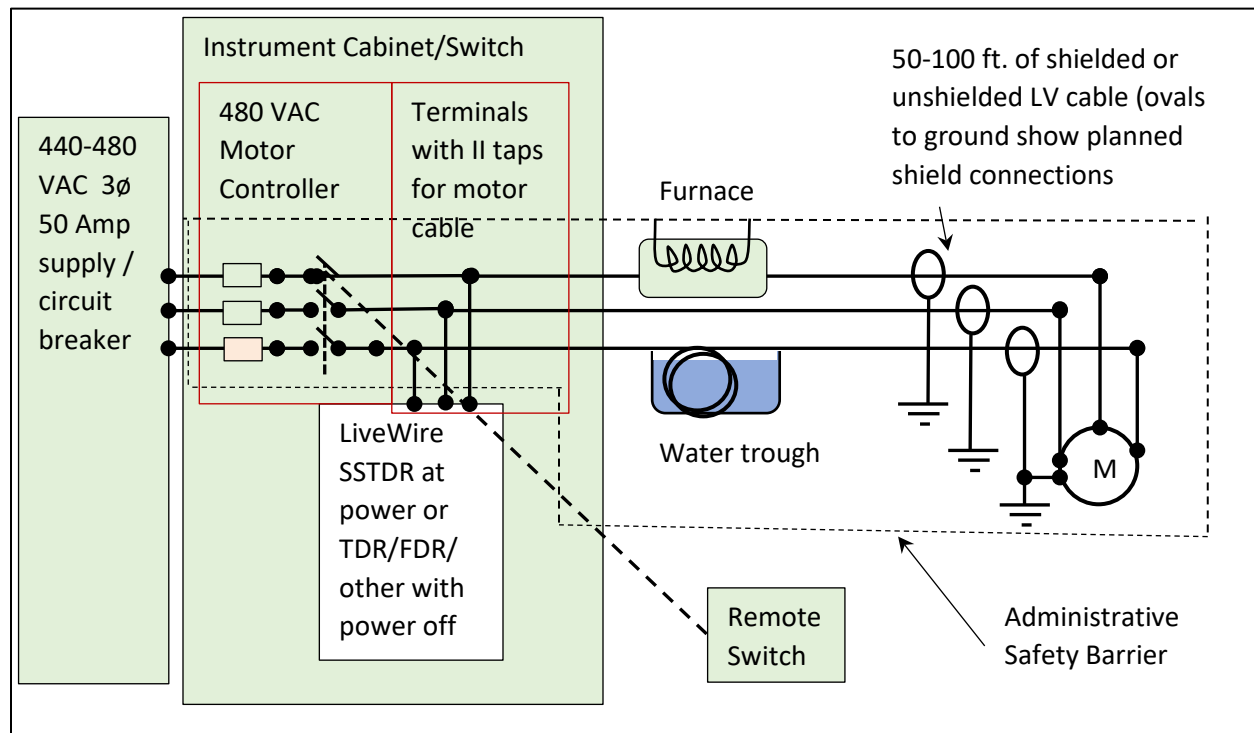

Figure 1 Overview of ARENA Cable Motor Test Bed

The ARENA system is designed to minimize risk to the system operators and the facility while maximizing the flexibility to test NDE instruments and strategies under a wide variety of cable damage and environmental challenge scenarios. The 480 VAC 3-phase configuration was chosen to resemble the most common motor/actuator circuits in nuclear power plants. The ARENA instrument cabinet (Figure 2) gets its power from a conventional 480 VAC wall socket coming from an electrical panel in the 2410 Stevens building on the Richland campus. This allows operators to work on the system without invoking PNNL lockout/tagout protocols. The instrument cabinet contains a thermal circuit breaker to protect the building power system should there be an electrical fault, an industrial motor control circuit with a remote pendant (Figure 3) to allow the motor control circuit (MCC) to be energized outside of the personnel restricted area. The instrument cabinet also includes a termination board to connect the MCC to the ½ HP motor (Figure 4) using either shielded or unshielded cables (Figure 5). Cables may be routed to the motor through an industrial oven with an interior space of approximately 2 ft³ and a water trough where cables can be submerged. Both the furnace and the water trough are available for offline or online energized cable exposure. The motor is a relatively standard 480VAC 3-Phase ½ HP motor mounted to an angle plate so that it may be moved within the test area. The mounting configuration does not support any motor load, but the system can be started and stopped thereby introducing motor start/stop transients.



Figure 2 AREVA motor control cabinet



Figure 3 Remote Control Pendant

Benefits

Onsite testing of cable NDE and cable online monitoring will be valuable to justify new instruments and approaches, but convincing utility operators to install untested systems onto safety critical systems will be challenging. Moreover, on-site opportunities to expose NDE and online monitoring systems to natural cable or motor degradation will be limited and virtually no operator will want to introduce faults in safety critical systems for NDE instrument performance verification.

By contrast, the ARENA test bed environment offers opportunities to introduce controlled component damage while monitoring the instrument response and without risking safety critical components. These faults can be introduced, and responses captured relatively quickly compared to an on-site setup thereby allowing a large number of failure types to be tested.



Figure 4 ARENA 480 VAC 3 Phase ½ HP Motor



Figure 5 Shielded and Unshielded cable spools

The ARENA test bed is also a simple system that can be modeled and simulated as a digital twin so observed instrument behavior may be better understood and alternate environmental or material degradations may be virtually evaluated where applicable.