

S-CAL RESEARCH CORPORATION

DOE/CE/15600-T7

FINAL REPORT

METHOD FOR CUTTING STEAM HEAT LOSSES DURING CYCLIC STEAM INJECTION OF WELLS

Contract: DE-FG 49 -93 CE 15600

By: Dr. M. Gondouin
S-Cal Research Corp.

Dated: December, 1995

DISCLAIMER

This report was prepared as an account of work sponsored by an agency of the United States Government. Neither the United States Government nor any agency thereof, nor any of their employees, makes any warranty, express or implied, or assumes any legal liability or responsibility for the accuracy, completeness, or usefulness of any information, apparatus, product, or process disclosed, or represents that its use would not infringe privately owned rights. Reference herein to any specific commercial product, process, or service by trade name, trademark, manufacturer, or otherwise does not necessarily constitute or imply its endorsement, recommendation, or favoring by the United States Government or any agency thereof. The views and opinions of authors expressed herein do not necessarily state or reflect those of the United States Government or any agency thereof.

MASTER

32 San Marino Drive • San Rafael, CA 94901 • (415) 456-8237

DISTRIBUTION OF THIS DOCUMENT IS UNLIMITED

pgs

Dlc

FINAL REPORT

METHOD FOR CUTTING STEAM HEAT LOSSES
DURING CYCLIC STEAM INJECTION OF WELLS

Contract CEC 500-92-053

TABLE OF CONTENTS

Summary and Conclusions
Abstract

1.OVER-ALL PURPOSE OF THE PROJECT

- 1.1 Background
- 1.2 Project Objective
- 1.3 Other Future Plans

2.SPECIFIC PERFORMANCE GOALS AND OBJECTIVES

- 2.1 Technical work plan
(Tasks 1.0 to 1.9)

3.APPROACHES TAKEN TO REACH THE TECHNICAL OBJECTIVE OF EACH TASK

- Task 1.0
- Tasks 1.1 and 1.5
- Tasks 1.2 and 1.6
- Taska 1.3 and 1.7
- Tasks 1.4 and 1.8
- Task 1.9
- Incidence on Air Pollution and on Energy Efficiency

4.ACHIEVEMENT OF OBJECTIVES

- Appendix 1 (Tasks 1.1 and 1.5)
- Appendix 2 (Tasks 1.2 and 1.6)
- Appendix 3 (Tasks 1.3 and 1.7)
- Appendix 4 (Tasks 1.4 and 1.8)

5. NEXT STEPS TOWARD COMMERCIALIZATION

6. SPECIFIC BENEFITS OF THE NEW TECHNOLOGY

- Table 1
- Fig.1 and 2
- References (1 to 5)

METHOD FOR CUTTING STEAM HEAT LOSSES
DURING CYCLIC STEAM INJECTION OF WELLS

Contract No. De-FG 49-93 CE 15600

SUMMARY AND CONCLUSIONS

Heavy Oil is abundant in California. It is a very viscous fluid, which must be thinned in order to flow from wells at economical rates. The best method of oil viscosity reduction is by cyclic steam injection into the oil-containing rock formations. Making steam in conventional generators fueled with Natural Gas is, however, a costly process.

The main objective of this Project is to reduce the cost of the required steam, per Barrel of Oil produced.

This is made possible by a combination of Patented new technologies with several known methods.

The best known method for increasing the production rate from oil wells is to use horizontal drainholes, which provide a much greater flow area from the oil zone into the well. A recent statistic based on 344 horizontal wells in 21 Canadian Oil fields containing Heavy Oil shows that these are, on the average six times more prolific than vertical wells.

The cost of horizontal wells, however, is generally two to three times that of a vertical well, in the same field, so our second goal is to reduce the net cost of horizontal wells by connecting two of them to the same vertical casing, well head and pumping system. With such a well configuration, it is possible to get two horizontal wells for the price of about one and a half times the price of a single vertical well.

There are also many other advantages to this well configuration which is used for simultaneously injecting steam in one of the twin drainholes, while producing heated oil from the other drainhole:

1) The steam tubing is in close proximity of a hot production tubing, within a low-pressure gas-filled vertical well casing. In this arrangement, the gas-filled annulus is maintained at high temperature by the production tubing, which carries the hot fluids (water and oil) produced from the oil rock to the surface. As a result, the heat loss from the surface of the steam-carrying tubing is drastically reduced, so that more of the steam delivered by the generator reaches the bottom of the well without condensing. The higher the quality of the steam injected into the oil rock, the more effective it is in thinning and displacing oil within the rock, thus further increasing the well productivity. After a period of steam injection in one drainhole, it is placed under oil production. Conversely, the other drainhole, originally under production is converted to steam injection. This new mode of well operation is called Oil Recovery by Sequential Cyclic Steam Injection.

2) The steam generator and the dedicated steam tubing, used to alternatively deliver steam to one or the other of the twin drainholes, operate more efficiently on a continuous basis.

3) The constant delivery of steam downhole and the availability of Downhole

Valves, operated from the surface at low cost, also allows to divert a very small slip stream of hot steam to the producing drainhole to lift the production stream, consisting of about 80 % boiling water and 20 % hot oil, over the curved portion of the drainhole, covering a 300 ft difference in elevation where conventional rod pumps would be subject to rapid wear.

4) The combination of a partial steam lift with a vertical rod pump is made possible by the use of a Downhole Oil Separator/Sump, at the bottom of the vertical casing. In this separator, most of the sand entrained by the viscous oil is separated out and never enters the rod pump, thus greatly increasing the pump's operating life.

5) The pressure in the Downhole Oil Separator is that of gas filling the casing (i.e. near atmospheric). Consequently, the net draw-down differential pressure of the producing drainhole is maximized. This correspondingly increases the well production rate.

6) The differential pressure of injected steam in one drainhole and of a low-pressure production stream in the producing drainhole require that high-temperature, leak-tight seals be used in all the well tubular connections (liners to casing, curved tubing to liner, steam tubing to liner/curved tubing annulus). This is made possible by suitable design and pre-fabrication of all these connections and by the selection of proven sealing materials.

7) The problem of sand production, frequent in California Heavy Oil fields, is further alleviated by completing the horizontal part of the drainholes with gravel-packed liners, slotted "in situ", so as to facilitate gravel placement and compaction. A slot-cutting tool was designed, built and tested for that purpose. It is expected to greatly improve the reliability of conventional gravel packing in horizontal wells, at a much lower cost than that of pre-packed filters.

8) The elimination of the need for a service rig each time that the mode of operation is changed from injection to production will also reduce operating costs.

9) The new Downhole 3-way steam valve and the transferable plug used to perform this switch in the mode of operation of the well are both wireline-operated, using available tools and low-cost proven techniques.

10) The entire technology is also compatible with the use of a Downhole steam generator, developed separately, which will allow to economically recover Heavy Oil from deeper, undepleted reservoirs requiring high pressure steam.

FOLLOW-UP

The Downhole Hardware and tools developed under the present Contract must now be field-tested to demonstrate their reliability and to confirm the economic benefits of this new technology. In order to save costs, the same well and drainholes will be used for successively demonstrating this technology and that of a new type of Downhole steam generator. A License Agreement and the establishment of a

Limited Partnership for the Field Test are in preparation for the next phases of development and marketing.

CONCLUSIONS

All the pre-requisites are now in place for a full demonstration of our new technology, which has the potential of reviving the production of many fields now on the verge of abandonment, thus increasing recoverable reserves of Domestic Heavy Oil.

Following a successful Field Test, a large market will open-up for all the elements of this technology, because it has the potential of greatly increasing the production of Heavy Oil in California. This will create a large number of oil field service jobs in California.

Energy savings and reduced atmospheric pollution are also expected when this technology is widely adopted by the California Onshore Oil Operators. Significant markets will later open-up in other States and in Foreign Countries (Canada, Venezuela, Mexico and Trinidad), linked to the US by NAFTA. Finally, the large Heavy Oil resources of Russia and of China may provide the impetus for a Worldwide marketing effort.

The compatibility of this technology and hardware with various types of Downhole Steam Generators may further extend its application to the recovery of Heavy Oil from deeper, undepleted reservoirs, even under very adverse environmental conditions, such as in the Arctic, below the Permafrost and in deep sea Offshore reservoirs.

The extension of this technology to the recovery, by steam, of Light Oil remaining in old, watered-out or undepressed fields is the subject of a proposal for additional Field Testing at the DOE Rocky Mountain Oil Testing Center.

METHOD FOR CUTTING STEAM HEAT LOSSES
DURING CYCLIC STEAM INJECTION OF WELLS

Contract: DE-FG 49 -93 CE 15600

ABSTRACT:

Under the present Contract, special Downhole Hardware and Tools were developed, built and shop-tested in preparation for a Field Test of a new technology for drilling, completion and operation in sequential cyclic steam injection of vertical wells equipped with twin horizontal drainholes.

This new technology is covered by three US Patents. Its goal is to reduce the Capital and Operating Costs, per Barrel of Oil produced from known Heavy Oil reservoirs, located primarily Onshore in California.

These cost reductions are essential to the continuation of exploitation of many marginally economic Domestic Oil Fields under the prevailing low oil prices. They are made possible by a combination of improvements including: 1) a well configuration and operating process leading to the reduction of steam tubing heat loss,

2) a reduction of sand production problems by better gravel packing behind the liners of the horizontal drainholes, by a Downhole Oil Separator / Sump and by use of a vertical rod pump,

3) maximizing the production rate by partial steam lift of the production stream over the curved part of the horizontal drainholes,

4) eliminating the need for whipstocks and for milled casing windows, while providing better sealed connections between liners and casing,

5) using a single pump and pumping unit for both drainholes, thus reducing capital and operating costs,

6) eliminating the need for a service rig at the end of each injection cycle.

The project was divided into 9 technical Tasks, following an extensive consultation with Operators to identify the problems and limitations that they face in various Heavy Oil reservoirs.

Four specific items had to be designed, built and shop-tested:

1) a Slot-cutting tool to be used in-situ to cut slots through the liner walls after displacement and compaction of gravel behind the horizontal liners,

2) Special Casing Joints, containing tubular internals, to become part of the vertical casing string, run-in and cemented to facilitate the drilling and completion of the twin horizontal drainholes, and an "H" Joint to connect them to the steam tubing and to the Downhole Oil Separator/Sump,

3) A Kick-over tool used in the wireline operation of a transferable plug within the "H" Joint, at the end of each injection cycle,

4) A Downhole 3-way Steam valve to be included in the steam tubing string, for the distribution of the injected steam and lift steam to one or the other drainhole.

Many of these new devices required seals to operate. Their selection based on their environment and operating conditions was the 9th

technical Task.

Detailed Drawings and Specifications were effective in getting our Contractors to machine, weld and assemble all our proprietary devices.

The approaches taken to reach these objectives were to provide maximum operational flexibility, regarding the origin of the injected steam, the type of rod pump required for wide variations in reservoir conditions, and to make use, as much as possible, of field-proven devices and techniques, already offered by Oil Field Service Companies.

This was made possible by the technical cooperation of OTIS, BAKER and of the UC-Berkeley Petroleum Engineering Program.

The next steps include the signing of a General Licensing agreement with another small Company who owns patents and prototype equipment which are fully compatible with our own, so that the cost of Field-Testing and marketing could be shared. Negotiations to that effect are now at a very advanced stage.

The benefits of our technology are primarily economic, leading to the creation of additional jobs in order to revive many Oil Fields currently on the verge of abandonment. Energy savings and reduction of Atmospheric Pollution are also expected from this development.

METHOD FOR CUTTING STEAM HEAT LOSSES
DURING CYCLIC STEAM INJECTION OF WELLS

Contract DE-FG 49-93 CE 15600

1.OVERALL PURPOSE OF THE PROJECT

1.1 BACKGROUND

The benefits of a horizontal well for increasing well productivity in relatively thin layered reservoirs are now well recognized.

A few of them have been successfully used in steam injection Enhanced Oil Recovery (EOR) projects in the Heavy Oil fields of California.

More recently, the economic merits of using dual horizontal wells connected to the same vertical cased wells were recognized by the Union Pacific Resources Company (UPRC) for twin drainholes completed in open hole in the Austin Chalk, as shown in the attached excerpts (Ref.1) from the July, 1993 JPT (Journal of Petroleum Technology, a professional publication of the Society of Petroleum Engineers). This approach is not applicable to the largely unconsolidated sand formations of California, which require liner-equipped drainholes.

When used in a steam injection project, the connection between a liner and the cemented vertical casing must be designed to withstand thermal stresses and it must remain pressure-tight in order to be operated successively as a steam injector and as a producer in the commonly-used cyclic steam injection operating mode. These requirements are much more severe in the case of twin horizontal drainholes than in the case of single horizontal wells. This is because the length of the line of contact between liners and casing is much greater.

The S-Cal technology addresses these problems by several inventions:

1) US Patent No.5,085,275 which describes the PROCESS FOR CONSERVING STEAM QUALITY IN DEEP STEAM INJECTION WELLS.

2) US Patent No.5,462,120, issued on 10/31/95, which describes the DOWNHOLE EQUIPMENT, TOOLS AND ASSEMBLY PROCEDURES FOR THE DRILLING, TIE-IN AND COMPLETION OF VERTICAL CASED OIL WELLS CONNECTED TO LINER-EQUIPPED MULTIPLE DRAINHOLES.

3) US PATENT No.5,052,482, describing the three-way downhole valves which are required to implement this process by downhole switching from the steam injection mode to the oil production mode of each drainhole. These types of valves have been successfully designed, built and tested as part of a joint project with UC-Berkeley, with partial funding from the State of California Commerce Department (California Competitive Technology Program-CCTP) to UC-Berkeley. As part of this project, calculations were made of the tubing heat losses under various assumed conditions. The results obtained are presented in Ref.2, the 1993 MS Thesis of S.Zeyrek, which was closely supervised by the Principal Investigator. These results have already been submitted to the CEC Project Manager. They are also in very good agreement with those presented in the book "Thermal Methods of Oil Recovery", by J.Burger, P.Sourieau and M.Combarous, Gulf Publishing Co., 1985 Ref.3 (shown in Fig.1. This is very encouraging, because the numerical simulators were quite different and the assumed thermal properties were also different. It would be futile to spend any more time on this

subject, which remains purely academic, as long as the results are not quantitatively matched against actual field data.

This, however, was the case of the work published by Texaco in 1982 where the results of a proprietary thermal simulator were compared with the data measured in an instrumented well presenting a dual tubing completion similar to the type of completion in which the prototype downhole hardware resulting from the present project will be incorporated. This SPE Paper, of course, does not provide the parameters which were adjusted in the model to achieve this good match. These certainly include the following, for which no experimental measurements are available in any actual oil well, except for a range of "reasonable" values:

- thickness of the oxide scale on all the tubular surfaces,
- heat transfer coefficient of the scale layer by conduction,
- heat transfer coefficient of condensing steam to the scale layer, inside the steam tubing,
- heat transfer coefficient of the two-phase production stream to the scale layer, inside the production tubing,
- heat transfer coefficient by radiation and convection from the outer scale layer to the gas phase in the casing annulus,
- heat transfer coefficient, by convection and radiation from the annulus gas to the inner scale layer of the casing,
- heat transfer coefficient, by conduction, from the outer scale layer on the casing to the cement layer,
- average thickness of the cement layer.

None of these 8 parameters is ever known with any accuracy for an actual well. This is the main justification for their adjustment, within a "reasonable" range, in any thermal simulator, such as the one used by Texaco. Indeed, the matching results of all reservoir model types with the past production history of a field proceeds on the same basis, by "reasonable" adjustment of parameters which remain unknown. It is an accepted method in the Petroleum Industry, despite the recognized fact that such sets of "matched parameters" are not unique. Indeed it has been shown that their validity is only of a probabilistic nature.

Because Texaco has already done this work of matching its thermal simulator parameters to achieve a satisfactory agreement between the measured temperatures and heat rates in its instrumented well and the predictions of the simulator, there is no need to repeat it, as part of this project, while delaying the realisation of the Project Objective.

1.2. PROJECT OBJECTIVE

The objective of the present project is to design, build and shop-test the prototype downhole equipment required for a field demonstration of S-Cal Research's patented technology.

Application of this technology in a Heavy Oil field such as the Midway-Sunset, the largest California oil field, would make it affordable for small Independent Operators to use steam injection in their leases, which are generally marginal compared to those of the Major Oil Companies. The productivity improvement resulting from this more economical and more effective way of using steam in leases where presently, without steam, the average daily well rate is less than 5 Barrels per day and thus uneconomic at current oil prices could be a factor of 20 to 50, with a more probable value of 30. Correspondingly the capital to be invested by Small Independents per Barrel of oil produced would be drastically reduced. Consequently, a greater portion of the Midway-Sunset and of other California Heavy Oil fields would become economically recoverable by steam injection methods.

The attached list of Operators of Steam Injection Projects in the Midway-Sunset field shows that only Major (Integrated) Oil Companies and Large Independents have had the financial resources to use these methods, but there are also many smaller owners of oil reserves in the Midway-Sunset, who would bring their oil to market if capital costs were drastically reduced.

Operating costs of wells in Steam injection Projects would also be reduced by using twin horizontal drainholes, which can each access a much greater portion of the reservoir. Savings as large as 30 % on a per Barrel basis appear possible, due to the increase in steam effectiveness.

These theoretical benefits must, however, be demonstrated in the field for the new technology to be widely accepted. This will be subject of future work, not covered under the present Contract.

Our proposal considered the application of our new technology to existing wells, presently shut-in and under high risk of abandonment. This is ultimately the largest market for our products but, in conversations with many California Operators and investors, it became clear that it would be preferable, for the first field application of our technology, to minimize the technical risk by drilling a new well instead re-entering into an old well, in which the exact condition of the existing tubulars is very uncertain. The cost difference between drilling a new and the re-entry into an old well may also be eliminated if our field test is made with partial funding from the Department of Energy (DOE).

For this reason, the prototype downhole equipment to be built and shop-tested under the present contract had to be re-designed for use in a newly-drilled well, rather than for a smaller 7"OD casing.

S-Cal Research negotiated with a California Operator the acquisition of a lease for field testing its technology under a joint proposal to the DOE, as part of the Class 3 Oil Program.

This negotiation, which was not planned in our proposal, because the timing and possibility of DOE funding of a California Operator for a field test under the DOE Class 3 and 4 Oil programs were not known in 1992, has led to a new task 1.0 called "Technology Transfer". Its purpose is to define the best dimensions of the ETAP prototypes to maximize the chances of their rapid utilization in a field test:

This being the most essential step towards commercialisation of our proprietary technology, for which the prior investments made by S-Cal Research and the future investments to be made by the Operator and by the DOE greatly exceed the budget of the present project, all efforts have to be concentrated on this single objective, which is much more likely to create jobs and wealth in California than the repeat of Texaco's published work on heat transfer, which would only be of academic interest at this time.

If our field test is successful, showing an increase in well productivity and increased oil volumes per cycle, temperature log data may then be used to determine the increased efficiency of the injected steam under this technology. This will provide an indirect confirmation that the injected steam is indeed of higher quality than the steam injected in neighboring wells, using conventional technology. This "a posteriori" confirmation of Texaco's work will be obtained at very low additional cost and will no longer detract from this Project Objective.

1.3 OTHER FUTURE PLANS

This joint proposal was unsuccessful and the DOE Class 4 Program was cancelled by the DOE, thus eliminating this funding source. The Partnership was terminated but S-Cal Research subsequently found another partner. He owns a new patented technology and a shop-tested heater prototype which, when combined with a Downhole Heat Exchanger / Steam Generator, will form a system benefiting from the reduction of tubing heat losses achievable with the S-Cal Research patented Process and Downhole Hardware. This new Partnership, with Future Energy, Inc., is also financially and technically much stronger than the previous one. It is currently exploring various ways of field-testing together their two technologies, while sharing the well costs.

The First Phase will cover the S-Cal Research technology alone which will be tested independently, using a conventional steam generator.

The Second Phase will test both technologies in combination in the same well, equipped with twin drainholes to be drilled and completed using S-Cal Research's prototype equipment designed and built under the present Contract. Steam will be generated downhole at reduced cost, using a circulation of heating fluid obtained from the existing prototype heater of Future Energy Inc. and the concentric tubing and a Downhole Heat Exchanger / Steam Generator being jointly designed under a separate project.

After completion of a successful field test in a new well, the case of re-entry into an existing well will be re-opened with less risk and it is hoped that this will include the participation of a Service Company, as part of negotiations leading to a license agreement.

A useful additional simulation work, following the acquisition of field data, would be the modification of the numerical model of heat transfer between parallel tubings built by Simulation Sciences, Inc. and described by S. Barua in a 1992 SPE Paper. This model, built by a Brea, California, Small Business, specialized in providing numerical services to Oil Operators, could easily be adapted to describe the multiplicity of the various tubing configurations (insulated or not) and pipe sizes compatible with in any given casing size. This would allow the optimization of the tubings, from the stand point of heat transfer as well as that of fluid flow. It could become a valuable additional service on that specialized company's catalog, provided that their model be first matched with the data obtained from a suitable field test, such as the one we will be pursuing, after completion of the ETAP project. For its part, S-Cal Research is prepared to work with Simulation Sciences, Inc. towards that technical goal, but it does not intend to ever provide this kind of services to the Oil Industry, nor to enter this field of activity, in which it holds no proprietary advantage. Prior conversations with S. Barua have indicated his interest in such a technical cooperation, if funding and field data can be made available to such a new small project.

The tubing heat loss reduction relative to the Phase 2 tubing configuration used for the combined test of the S-Cal Research Process and Downhole Hardware with the Downhole Heat Exchanger / Steam Generator of S-Cal Research's new Partner will provide an additional set of field data. These can later be simulated with the Simulation Sciences, Inc. software package, thus providing a wider range of heat exchange parameters relative specifically to the same well casing and cement thermal properties. The individual benefits of both technologies can thus easily be compared and quantified for each technology, despite the inherent uncertainties about thermal properties of casing and cement sheath. This computer-based interpretation of results may be the Third Phase of the future joint Field Test, if sufficient funds become available.

Horizontal Technology

UPRC also is using other forms of lateral wellbores to improve production and profit, including the dual-opposing lateral since 1991. "One of the most important aspects of horizontal drilling is controlling costs," said Bill Kleinsorge, SPE, engineering supervisor. "We've been drilling more dual-opposing laterals because they reduce costs more than any other advancement. We drill vertically to the top of the chalk, then drill the laterals in opposite directions. Laterals actually increase the individual-well cost but decrease total development costs because you virtually get two wellbores for the price of about one and one-half wellbores."

The company drilled its first 14 dual-zone lateral wells in 1992 and plans several more this year. "We can use dual-zone laterals where the reservoir has separate zones that don't communicate vertically," Kleinsorge said. The benefits are the same as for opposing laterals, where one wellbore doubles the amount of reservoir intersected and avoids the cost of operating a second well.

"The biggest problem in drilling laterals is that it makes running liners more difficult and less effective," he said. "And there is no such thing as a simple casing 'Y' that goes in both laterals."

Winters added that liner-hanger systems are just beginning to appear for these multi-branch wells. "Baker Oil Tools and a U.S. operator developed a dual vertical liner hanger," he said. "Recently Sperry Sun and a Canadian operator developed a clever method for installing any number of liners branched from the lateral segment of the well. Hopefully, this type system will become available outside Canada."

~~Where re-entry laterals are drilled,~~ such slim-hole techniques as coiled-tubing drilling are particularly useful, especially in the U.S. and Canada where casings tend to be smaller, according to Winters. Coiled tubing also allows underbalanced drilling, which reduces the chance of wellbore damage from drilling-fluid invasion: comes in electric-wire compatible form; and, in theory, saves money because it facilitates tripping in and out of the well rather than dealing with drill-string joints, he added.

"Coiled tubing was the hot topic about a year ago," Winters said. "It does have the potential for economical application, but right now it is expensive and still going through the normal cycle of problem solving and technology development."

July 1993 • JPT

Table I

**Slope-Basin & Basin Clastic Reservoir Steam Projects
Within the Midway-Sunset Field by Operator (April 1992)**

Operator	Pay Zone	Start Date	Area (Acres)	Wells		Inc. Oil (BOPD)
				Prod.	Inj.	
Arco	Potter	72	8	31	4	880
Arco	Potter	75	108	98	15	3,800
Arco	L. Monarch	83	34	13	2	1,300
Arco	Monarch	81	40	70	10	2,475
Arco	Monarch	72	9	35	4	485
Arco	Sub. Lake	84	15	12	0	105
Arco	Metson	69	50	60	15	1,125
Arco	Potter	72	200	50	3	500
Arco	Potter+	--	--	40	1	2,100
Arco	Potter	77	107	210	18	7,000
Arco	Potter	86	40	77	0	750
Arco	Potter+	--	80	95	11	900
Arco	Potter+	--	70	59	4	600
Arco	Potter+	90	80	188	5	5,000
Arco	Potter	90	120	247	4	7,000
Arco	Marviz	--	80	36	4	650
Arco	Potter	86	160	236	80	3,200
Chevron	Potter	78	23	36	5	2,650
Chevron	Monarch	75	84	243	81	9,000
Chevron	Webster	83	84	44	10	2,300
Exxon	Monarch	90	--	200	100	1,300
Mobil	Monarch	70	400	381	32	8,300
Mobil	Potter	67	140	376	21	10,500

Table I (Continued)

**Slope-Basin & Basin Clastic Reservoir Steam Projects
Within the Midway-Sunset Field by Operator (April 1992)**

Operator	Pay Zone	Start Date	Area (Acres)	Wells		Inc. Oil (BOPD)
				Prod.	Inj.	
Santa Fe	Potter	85	100	350	45	4,350
Santa Fe	Potter	64	900	880	--	15,900
Santa Fe	Spellacy	70	400	500	--	4,000
Santa Fe	Spellacy	91	30	30	8	0
Shell	U. Spellacy	79	70	66	0	1,300
Shell	Lower	89	68	78	10	1,300
Shell	Sub. Hoyt	83	143	205	26	5,700
Shell	Potter	71	400	650	34	12,500
Shell	Monarch	80	85	145	12	4,400
Texaco	Potter	81	77	27	9	1,422
Texaco	Potter	77	27	51	7	565
Texaco	Potter	89	38	62	11	880
Texaco	Potter	91	24	24	6	100
Texaco	Potter	77	36	72	15	1,200
Unocal	Potter	74	81	59	19	614
Unocal	Potter	77	50	79	20	1,550
Unocal	Potter	69	150	165	0	2,000
Total			4,600+	6,280	651	130,101

Source: Oil and Gas Journal EOR Database, April 20, 1992.

Note: A total of 5,392 cyclic steam wells and 785 steam drive injectors are listed in the 77th Annual Report of the State Oil and Gas Supervisor (Reference 6, p. III-30) for the Midway-Sunset field. The variation between the numbers reflects reporting discrepancies as well as the inclusion of steam drive producers in the "producing wells" total above.

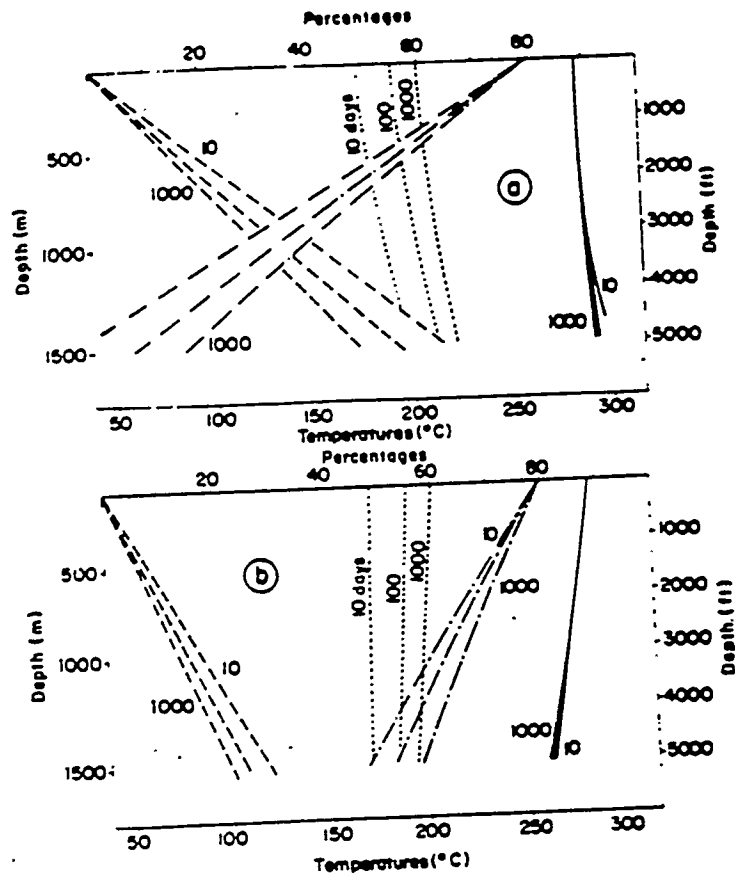

Fig. 4.9 Heat loss in the well for condensing steam. Results from a numerical model [4]

80% quality steam is injected into the tubing at 7 MPa (1,000 psi). The diameter of the drill-hole is 10 cm, the casing 15 cm and the tubing 2 cm. Tubing emissivity ϵ , is 0.9. The annular space which is insulated with a packer is filled with air at low pressure.

- Percentage heat loss
- Temperature of the casing
- - Steam temperature
- . Steam quality

(a) Injection rate: 2,720 kg/h (6,000 lb/h) (b) Injection rate: 5,440 kg/h (12,000 lb/h)

Figure 1

2. SPECIFIC PERFORMANCE GOALS AND OBJECTIVES

2.1 TECHNICAL WORK PLAN

Other than the Reporting and Invoicing Tasks, the Project was divided into 9 Technical Tasks:

TASK 1.0 - Technology Transfer / Market Research

This Task's purpose is to determine the main dimensions of casing joints and liners required for acceptance by California Operators interested in participating in a future field test of S-Cal Research's new technology. This also helped to define the potential market for our technology.

TASK 1.1 - Preliminary Design of the Slot-cutting Tool

Liners currently used for Cyclic Steam Injection in most Heavy Oil reservoirs are pre-slotted and vertically gravel packed. In horizontal wells, however, proper displacement of gravel over long distances behind a pre-slotted horizontal liner is difficult to achieve, because of leakage through the slots of the suspension fluid (water with or without gelling agents). For this reason, the new technology uses liners which are run-in and gravel-packed prior to being slotted. The gravel suspension is then as easily displaced as a cement slurry, even behind horizontal liners. After displacement and break-down of the suspension, the suspension fluid invades the formation, leaving an uncompacted gravel pack. The Main functions of the Slot-cutting tool are :

- 1) to cut multiple narrow slots through the liner wall to establish flow communication with the formation,

- 2) to increase gravel compaction, in the vicinity of the slots, as a result of the liner wall plastic deformation during the slot-cutting process. The hydraulically-extended cutters are designed to maximize the gravel compaction in the liner annulus opposite each slot.

- 3) to operate at the end of a coiled tubing having a pressure rating of 10,000 psi or less.

TASK 1.2 - Preliminary design of the Special Casing Joints

Based on the informations gathered from various Operators, a vertical casing string of 10.75"OD was selected, with liner strings of 3.5"OD in the horizontal part of the drainholes and 4" or 4.5"OD in their curved parts.

The main functions of the Special Casing Joints are:

- 1) to guide the drilling tools along the path prescribed for each drainhole. As such they replace conventional whipstocks.

- 2) to provide leak-proof connections between the vertical casing and the drainhole liners, despite large differences in temperature and pressure, during operation of the well,

- 3) to provide reliable high-temperature flow connections between drainhole liners and well tubing assemblies. These include curved tubings, downhole 3-way valves, downhole oil separator/sump, rod pump, etc...

- 4) to provide flexibility of well operation in various reservoir conditions. This includes the possibility of using various kinds of rod pumps, at various depths and the possibility of combining partial steam lift to the downhole separator/sump, in the curved tubing, with standard

rod pumping from the sump to the surface, in the vertical production tubing. This last type of well operation is very advantageous to maximize production from low-energy reservoirs. It is made possible by the continuous availability of steam in the same casing as the production well, a main feature of our patented well configuration and process,

5) to minimize well down-time and operating costs in cyclic steam injection by eliminating the need for a service rig at the start of any new cycle,

6) to provide for easy replacement of tubings and rod pump over the life of the well.

TASK 1.3 - Preliminary Design of a Modified Kick-over tool

This Task's purpose was to make possible a wireline run-in, transfer or retrieval of conventional plugs at the entrance of each drainhole by means of an available kick-over tool, currently used to handle gas-lift valves. Wireline services (slick-line unit) are considerably cheaper than those requiring a rig.

TASK 1.4 - Preliminary design of a three-way downhole steam valve

A three-way steam valve is required to direct the flow of steam from the bottom of the steam tubing to either one of the twin drainholes.

In addition, when using partial steam lift of the production stream into the downhole separator/sump, the same valve simultaneously directs:

- 1) a large fraction of the total steam flow into the curved tubing and horizontal liner of the drainhole under steam injection,
- 2) a small fraction (a few percent) of the total steam flow into the annulus curved liner/curved tubing of the producing drainhole in order to steam-lift the production stream.

In view of the limited resistance of seals when used in steam service, it is desirable to periodically bring them to the surface for inspection and repairs. This is possible with wireline-operated valves but not with hydraulically-operated tubing valves. In that second case, the steam tubing assembly, including the hydraulic line, must be pulled out by means of a service rig. Accordingly two different designs have been produced, to address both cases.

TASK 1.5 - Construction and shop-testing of the slot-cutting tool

Preliminary shop tests were made to determine the magnitude of the force to be applied to the cutter arms and to select the cutter wheel profile which requires the smallest force to achieve the desired slot width with maximum local compaction of the gravel pack.

These tests led to a modified tool design. There are now three cutting arms at 120 degrees from each other, extended by two hydraulic pistons operating in tandem and retracted by a spring located within a gas-filled cylinder.

The tool is sufficiently short to easily go through a 4" OD curved liner of 250 ft radius of curvature in order to cut slots in a 3.5" OD horizontal liner. The tool is designed and built for complete disassembly and cleaning after each liner-slotting job.

TASK 1.6 - Construction and shop-testing of special casing joints

This Task includes the construction of four main elements: 2 special

casing joints of 11.75"OD (the same OD as that of the 10.75"OD casing string), one of them equipped with four tubular internals, plus:

1 special casing joint of 10.75"OD, located just above the shoe, equipped with two tubular internals,

1 "H" joint, with 4.5"OD branches, containing all wireline-transferable plugs. Its lower branches are connected to two Polished Bore Receptacles (PBRs) and one of its upper branches is connected to the steam tubing assembly, through the 3-way steam valve

The tubular internals of each casing joint are welded to the vertical casing pipe, at their bottom parts, but their top ends are welded together into a plate which is free to move within the corresponding casing joint, under differential thermal expansion.

Special threaded couplings were also built to handle, connect or assemble together all special casing joints.

TASK 1.7 - Construction and Shop - testing of the modified kick-over tool

The dimensions of the "H" joint and of its internals were selected so that an existing OTIS kick-over tool can be used, without any modifications.

TASK 1.8 - Construction and shop-testing of modified sliding sleeve valves

The wireline retrievable design is based on the use of an OTIS landing nipple and of a lock mandrel fastened to two ported sleeves equipped with "O" ring seals. By pulling the mandrel to the surface and interchanging the relative positions of the two sleeves, it is possible to satisfy all the requirements, using proven technology.

The hydraulically-operated 3-way valve is derived from another field-proven OTIS Annular vent sleeve valve, modified by the addition of a second line of body ports and some throttling orifices for the lift steam.

TASK 1.9 - Material selection for Packing seals used in plugs and valves in steam applications

High temperatures and potential abrasion by wet steam make the selection of proper sealing materials important for this project. Fortunately, there is a large body of experience and many commercially-available products to choose from. The packings and "o" ring seals used in the new devices built for this project can easily be replaced without the need for costly well work-overs, because, to the extent possible, critical seals have been placed on retrievable parts.

3. APPROACHES TAKEN TO REACH THE TECHNICAL OBJECTIVES OF EACH TASK

TASK 1.0 - Direct contacts with Operators interested in Field-testing our technology revealed a wide variety of reservoir conditions which had to be considered in order to provide a widely applicable system.

Among the most important, we can list: a) low-energy reservoirs, which led to the concept of partial steam lift, in order to maximize draw-down from the producing drainhole.

b) frequent sand production problems, which justified the effort to improve the effectiveness of gravel-packing, by means of "in situ" slot-cutting of the liners, In addition, the possibility of using an "Omniferous" rod pump was

added in the design of of the Special Casing Joints. The concept of a Downhole separator/sump, allowing some of the produced sand to fall to the bottom rather than enter the rod pump.

c) a low-pressure gas-filled vertical casing presents a number of advantages; reduced heat transfer through the casing, reduced flowing back pressure against the producing drainhole,

d) extensive wear of the rods is to be expected when the rods are in a curved well. This justified the concept of a downhole separator and of a vertical production tubing, with a straight rod string,

e) tubings hung from the well head, with free thermal expansion at the bottom end are the cheapest ways to reduce thermal stresses in the well tubulars.

f) low cost of "slick line" service units, as compared with that of hydraulic control lines and tubing pull-out job.

g) existence of a significant potential market in the recovery by steam injection of Light Oil from partially depleted or watered-out reservoirs, in addition to the most prevalent use of steam for Heavy Oil recovery, which was our original target. The key to this Light Oil recovery market will be a reduction of the steam cost, per barrel of oil produced, which is precisely the main advantage of our technology.

APPROACH TAKEN FOR TASKS 1.1 AND 1.5 (Slot-Cutting Tool)

Considering that the practical pressure rating of the TRIPLEX pumps and of the coiled tubing commonly used in Oil Fields is about 10,000 psi, the size of the hydraulic pistons required to actuate the cutter arms of the tool could be derived from laboratory tests in which a representative cutting wheel is pressed into the inner wall of an actual OCTG 3.5" OD liner pipe and where the applied force is accurately measured.

These tests were conducted on one of the INSTRON hydraulic presses of the Materials Science Department of UC-Berkeley. They revealed that a force of about 13,000 lb per cutter was required to obtain complete shearing of the pipe wall, following its plastic deformation. The width of the resulting slots could easily be adjusted by control of the depth of penetration of the cutting wheel.

In view of the tool diameter limitation to a 2.875" OD for a 3.5" OD (3" ID) liner, this finding led to a re-design of the tool to reduce the number of cutters operated by the same pistons from 4 to 3 and to maximize the piston area by reducing as much as possible the wall thickness of the tubular tool body, serving also as hydraulic cylinder.

For an additional operating margin, the mechanism was linked to two pistons operating in tandem, capable of applying a total force of up to 80,000 lb, or 27,000 lb per cutter (more than twice the shear force measured on the INSTRON machine).

To obtain the required strength from the arms, cutters and rollers of the mechanism with an easily machinable steel alloy, a Maraging 300 alloy was selected. Prior to heat aging, it is relatively soft but its yield strength exceeds 300,000 lb after heat aging. Its hardness also

increases drastically. With this material selection, it was also possible to make all the fine adjustments of the machining tolerances of the mechanism while in its soft condition, because the subsequent heat aging treatment creates very little distortion of the machined parts.

After heat aging of the Maraging steel parts, the mechanism was reassembled and placed within a short piece of 3.5" liner pipe. The cutting arms were then extended by applying a controllable force by the piston of an INSTRON machine, in order to check whether the three hardened wheels could fully shear the pipe wall at the predicted force without over-stressing the "as-built" mechanism.

This second test was also used to measure the force required to simultaneously retract all the wheels from their respective slots. These data were required to select the spring element characteristics and to finalize the design of the hydraulic system.

In view of the high hydraulic pressure rating of the tool, piston packings were made with cup-type BAL seals, made of graphite-reinforced PTFE plastic energized by a cant spring. This type of seal, much more costly than the Nitrile Rubber "O" rings initially considered, presents a lower friction, when the hydraulic fluid is water, and it has a longer life.

All machining and heat treating were done in well-equipped shops in Berkeley, so as to get high quality products.

APPROACH TAKEN FOR TASKS 1.2 AND 1.6 (Special Casing Joints)

The required tubular goods were finally obtained from a supplier in Bakersfield, whose prices were a fraction of those of the MBE supplier from Houston, TX which had been previously considered.

The 5.5"OD casings used to make the curved channels were cold-bent at the fabrication facility of Pacific Pipe Supply in Oakland, because no such facility is available in the Bakersfield area.

The elliptical windows through which these curved channels are connected to the vertical casing joints, respectively of 10.75"OD for the BLSJ and 11.75"OD for the TLSJ, were hand-cut by Rico's Welding, along a template generated by S-Cal Research,

The 2" thick plates connecting the ends of the vertical internal pipes in both the BLSJ and the TLSJ were machined in Oakland.

The insertion of the internals into the windowed casing joints, the welding of the curved channels to the window edges and the welding of pipes and plates were all done by Rico's Welding in San Francisco, under the supervision of S-Cal Research. For all critical welds, made outdoors, favorable atmospheric conditions of low humidity were required, which caused some weather delays, but had no impact on Project costs.

APPROACH TAKEN FOR TASKS 1.3 AND 1.7 (Kick-over tool)

Kick-over tools are used by Oil Field Service Companies to run in and retrieve gas-lift valves from their corresponding downhole mandrels. Each Company's tool is designed primarily to operate with the proprietary devices of the Company. In the present case, the selected lock mandrels for the "H" joint were from OTIS, who has kick-over tools which may adapt to a large variety of gas-lift mandrels and valves.

The main operational parameters of the kick-over tool are the offset distance that must be covered by the slanted element, above the

knee of the tool, and the profile of the guiding groove used to trigger the bending of the knee. These data were obtained from OTIS and used in the design of our "H" joint, so that an existing OTIS kick-over tool could be used, without any modifications. This tool being available on a rental basis, this eliminated the need to duplicate it ourselves.

It also eliminated any potential risk of our unintentionally infringing upon OTIS patents covering their tool, if we had modified it.

APPROACH TAKEN FOR TASKS 1.4 AND 1.8 (Three-way Steam Valves)

The valves are derived from existing OTIS Downhole Flow Control equipment. For a system using steam generated at the surface, the valve is operated by wireline, through the steam tubing. This allows the easy periodic retrieval to the surface of the sliding sleeve, equipped with steam-resistant seals which can be inspected and replaced each time that the mode of operation of the twin drainholes is changed (i.e. every 3 to 6 months).

The retrievable sleeve assembly presents, between seals, a row of ports through which the injected steam flows, to reach a corresponding row of ports in the fixed valve body, leading to one or the other of two steam feeder lines, welded against the outer wall of the "H" Joint.

Another part of the sleeve assembly presents a row of smaller ports through which the lift steam flows, at a reduced rate, toward the steam feeder line of the production well. The relative position of these orifices, above or below the injection ports, determines which of the twin drainholes is under injection, while the other is under production with partial steam lift. This choice is made by interverting the relative positions of the two port-bearing threaded sliding sleeve parts in the assembly.

Blank sleeves may also be used in the sleeve assembly to stop all flow of steam into one or the other drainholes, if desired.

The sleeve assembly is fastened to the base of an OTIS retrievable lock mandrel, which fits downhole into a corresponding landing nipple in the fixed body of the valve. The function of this lock mandrel is to accurately maintain the sleeve assembly into its pre-determined position with respect to the ports in the valve body.

When steam is generated downhole, the steam tubing consists only of a short tube attached to the bottom of the downhole steam generator. The downhole steam generator is hung from the well head, at the bottom end of a concentric tubing assembly carrying respectively water and fluids providing the required downhole heat source. Such a concentric tubing assembly is not designed to provide a direct access to wireline tools for the operation of the 3-way steam valve. Instead, the valve is operated by hydraulic fluid conveyed from the well head through a small-diameter line, strapped against the outside wall of the tubing assembly. In that case, the 3-way steam valve is derived from an OTIS Annular Vent Sleeve Valve, equipped with steam-resistant seals and with modified ports. Any repair of the 3-way valve will be combined with an inspection of the Downhole Steam Generator. It requires pulling-up the concentric tubing assembly, Downhole Generator and valve by means of a service rig. All other downhole hardware, such as the "H" joint, steam feeder lines and twin PBRs may remain in the well during

this operation, if their respective seals are satisfactory.

In both cases, the opening of the production drainhole to the Downhole Oil Separator/Sump and the simultaneous closing of the upper end of the curved tubing in the producing drainhole are achieved by transferring a plugged-off lock mandrel within the "H" joint by wireline, using the existing OTIS Kick-over tool. Consequently, the only Downhole Equipment change required when using a Downhole Steam Generator are the replacement of a wireline-operated sliding 3-way valve by a hydraulically-operated 3-way valve and the substitution of a Concentric Tubing Assembly for a conventional bare steam tubing.

APPROACH TAKEN FOR TASK 1.9 (Seals materials selection)

Three distinct sealing problems have to be addressed:

a) within the hydraulically-operated Slot-cutting tool, hydraulic fluid pressures up to 10,000 psi are encountered, but the slot-cutting operation is performed at a relatively low temperature, prior to any steam injection. This allows the use of commercially-available seals made of spring-loaded cup-type PTFE rings.

b) within the "H" joint, the seals of the transferable plugged-off lock mandrel operate in hot oil and water and against a steam pressure. In addition to various commercial packing materials (Dupont's Kalrez), Graphite/wire packings may be used at high temperature.

c) within the 3-way steam valve, "O" ring seals made of various elastomeric materials are applicable, in addition to those of Case b). Tests made at UC-Berkeley, as part of the MS thesis of S.M. Zeyrek show that, with suitable design of the "O" ring groove and careful insertion of the sliding Sleeve Assembly into the valve body, even low-cost Butyl rubber is satisfactory, for static seals at steam temperatures up to 650 F.

The possibility of replacing all "O" ring seals in the sliding sleeve assembly used in conjunction with surface steam conveyed through a conventional bare tubing effectively limits the seals operation to that of the static seals previously tested at UC-Berkeley.

For the 3-way valve derived from the hydraulically-controlled OTIS Annular Vent Sleeve Valve, the manufacturer recommends the replacement of all seals with Kalrez "O" rings, which they have found to be satisfactory at high temperature.

INCIDENCE ON AIR POLLUTION AND ON ENERGY EFFICIENCY

The methods of fabrication and materials used for the construction of the Prototype Downhole Equipment and Tools covered by this Contract are totally conventional. Their incidence on Air Pollution and on Energy Efficiency during this construction phase are negligible.

The objective of using in the Oil Fields this new technology in the future is, however, to significantly reduce the Natural Gas consumption per Barrel of oil produced, by a more efficient use of the injected steam and by the elimination of the need for service rigs, and of the large engines required for their transportation, field erection and operation of, their draw works, at the end of each steam injection cycle. In many electrified oil fields, the rod pump, wireline winch and all auxiliaries of the Gas-fueled steam generator will be under clean electric power, thus reducing air pollution.

4. ACHIEVEMENT OF OBJECTIVES

All the Design Tasks (Tasks 1.1 to 1.4) resulted in detailed drawings and specifications from which parts have actually been machined, assembled or welded, by outside Contractors, using Conventional methods and tools. These Drawings and Specifications are provided in Appendices 1 to 4.

All Construction Tasks will be completed on or before March 31, 1996. The bulky and heavy Downhole Hardware will be immediately shipped by truck to a California Oil Lease where it will later be field-tested.

This will eliminate the unnecessary cost of warehousing them in the Bay Area after completion of their fabrication. The slot-cutting tool, however, will be retained in the Bay Area for demonstration to potential licensees.

5. NEXT STEPS TOWARD COMMERCIALIZATION

A general Licensing Agreement of the Downhole Hardware is currently under negotiation and is expected to be signed before March 31, 1996, with a California Company who owns some compatible technology and other prototype equipment. The combination of both Patented technologies and Prototype Equipments is the subject of a request for evaluation by NIST from our future General Licensee.

A Limited Partnership is being organized to fund the Field Testing costs of our technology and that of our General Licensee, with a budget of \$ 1.5 MM. This is intended to cover the cost of drilling, completion and operation of a new well equipped with twin drainholes, for a long enough period of steam injection, successively generated from the surface and later from a Downhole Steam Generator. Also included in this budget are all the various OTIS devices, equipment, tools and services which have been incorporated in the current designs.

The extension of these technologies to the recovery of Light Oil from partially depleted, low energy reservoirs, is the subject of a proposal to the DOE's Rocky Mountain Oil Testing Center, who would provide its Teapot Dome field and existing wells and drilling rig to evaluate the economic merits of this new technology, under a very different environment and at a lower cost than in California. The required budget cannot yet be determined, in view of the uncertainty regarding the 1996 DOE budget, which, hopefully, will be removed by March 31, 1996.

6. SPECIFIC BENEFITS OF THE NEW TECHNOLOGY

The Downhole Hardware and Tools developed under the present Contract, when used to drill, complete and operate a vertical well equipped with twin horizontal drainholes, under sequential cyclic steam injection, will drastically reduce the number of oil wells required to recover Heavy Oil from known reservoirs, in California and in other States.

The Capital cost per Barrel of oil produced will be reduced, thus making it economic to re-open shut-in fields.

The more efficient use of injected Steam, resulting from the reduction of tubing heat loss and from the improved placement of steam within the oil zones by means of horizontal drainholes will also reduce Operating cost per barrel of oil produced.

The impact of better well technology is beginning to be

recognized by Oil Operators. In a recent SPE Paper, (Ref 4) Shell Oil reported that the median improvement in well productivity of single horizontal wells over vertical wells under comparable steam injection in the same Heavy Oil field was 6 to 1. Fig.2

This statistically correct observation confirms the validity of our general approach, which is to make it more affordable for small Operators to drill, complete and operate these more complex, but much more prolific wells, which, up to now, have been used mostly by the few remaining Majors interested in Domestic Oil production.

Simultaneously, the Oil and Gas Journal (Ref.5) reports the large economic progress made in Canada by various improved steam injection processes using horizontal wells.

This indicates that the introduction of our technology in the field in 1996 will be timely. Alone or in combination with a Downhole Steam Generator, applicable in still deeper reservoirs, it is capable of significantly increasing the Heavy Oil recoverable reserves in California and in other States. This will result in the creation of more highly paid jobs in old Oil Fields, now on the verge of abandonment.

REFERENCES:

- 1) Panel Discussion, J.P.T, July 1993
- 2) MS Thesis Pet.Eng. UC-Berkeley, by S.M.Zeyrek, 1993
- 3) "Thermal Methods of Oil Recovery", by J.Burger, P.Sourieau, M.Combarous, Gulf Publishing Co., 1985
- 4) "Log Normal Distribution of Horizontal Well Performance", J.P.T. December 1995.
- 5) "Producing horizontal wells", by H.Sarma, K.Ono, Special feature, Oil and Gas Journal, Dec.11.1995.P.49-56.

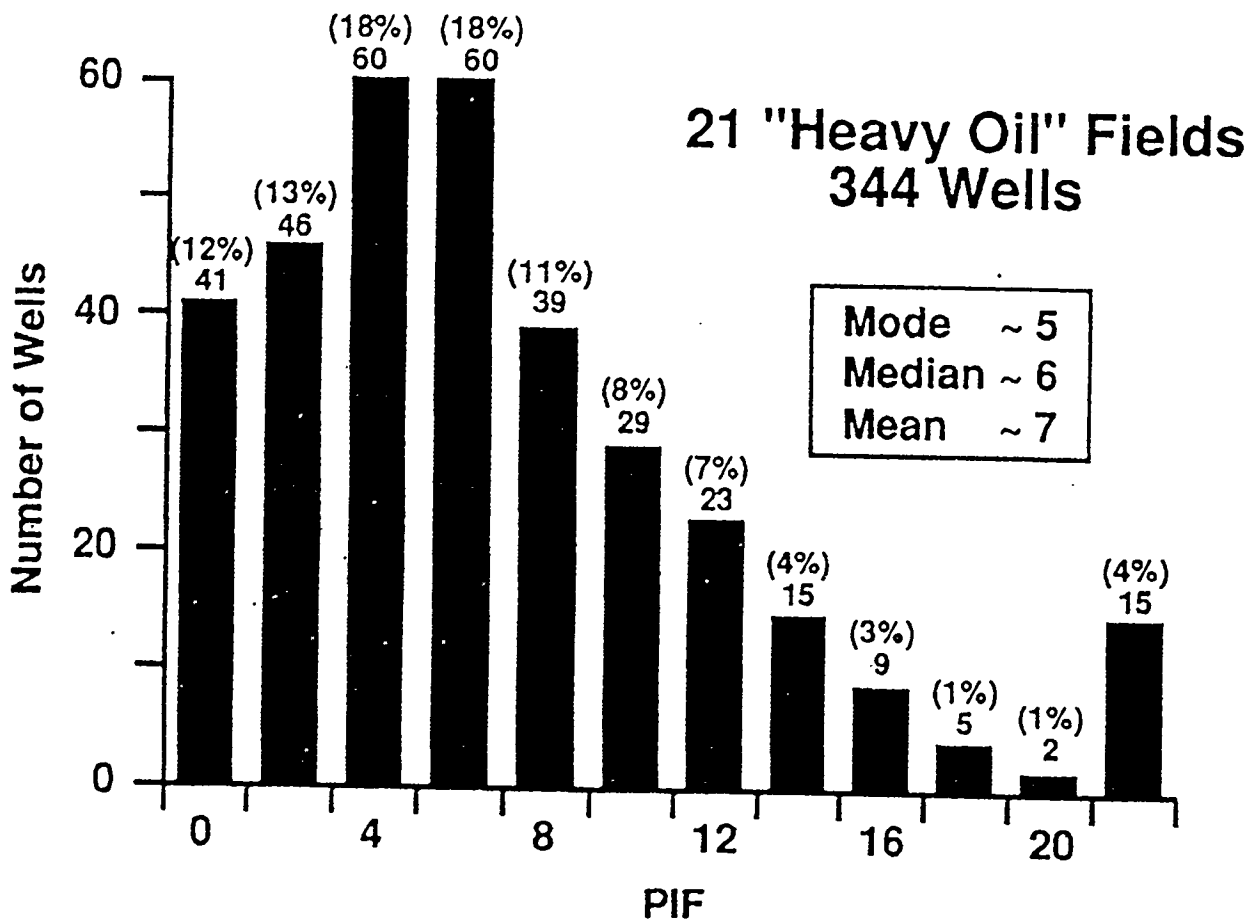

FIG.2 Statistical Distribution of the "Production Improvement Factor" (PIF) resulting from the use of single horizontal wells.

APPENDIX 1

DETAILED DRAWINGS, PHOTOGRAPHS AND TEST RESULTS OF SLOT-CUTTING TOOL
(Tasks 1.1 and 1.5 Deliverables)

APPENDIX 1

DESIGN AND CONSTRUCTION OF A SLOT-CUTTING TOOL FOR 3.5"OD LINERS.

(Tasks 1.1 and 1.5)

Deliverable : a) 1 Assembled and shop-tested hydraulically-operated slot-cutting tool
b) Detailed Drawings and Specifications

a) Photographs of the tool mechanism taken before and during shop tests on the INSTRON machine are presented.

Photographs of liner slots made during tests are also shown.
Force measurements vs. piston displacement taken during tests are included.

b) Machining of the tool mechanism was done using an end mill, on a manually-controlled milling machine. Drawings of each part and of the assembled tool are provided, but production in series with CNC milling machines should be based on actual dimensions of manually-adjusted and heat-treated parts of the prototype tool.

Material Specifications:

VASCO 300 C Maraging Alloy Steel, in annealed form, suitable for machining.

Heat aging at 1,500 F for 0.5 hour, followed by aging at 825 F for 3 hours.

Mechanical Assembly Procedure

1. Assemble cutting wheels on arms
2. Insert outer sliding guide
3. Insert arm head through each recess in the outer sliding guide
4. Insert retraction rollers
5. Place Y spacer
6. Place retraction rollers retaining plate
7. Insert the 3 pivots in the body
8. Insert the extension rollers retaining plate from above
9. Insert the extension rollers from above
10. Insert the upper central guide from above
11. Connect the hydraulic fluid line to the upper piston and to the top of the outer sliding guide, passing through the pivot plate hole
12. Insert the triangular lock from below
13. Insert and set the lock nut from below
14. Connect the lower posts of the outer sliding guide to the middle piston.
15. Connect the lower central guide to the bottom face of the middle piston
16. Install small BAL seal and face ring in the body
17. Insert the spring section
18. Adjust the spring compressive force using a torque wrench
19. Insert the lower hydraulic piston
20. Close lower hydraulic cylinder

21. Close upper hydraulic cylinder and coiled tubing head.

PHOTOGRAPHS OF SLOT-CUTTING
TOOL MECHANISM

1. with Cutting wheels extended
2. retracted on INSTRON Press

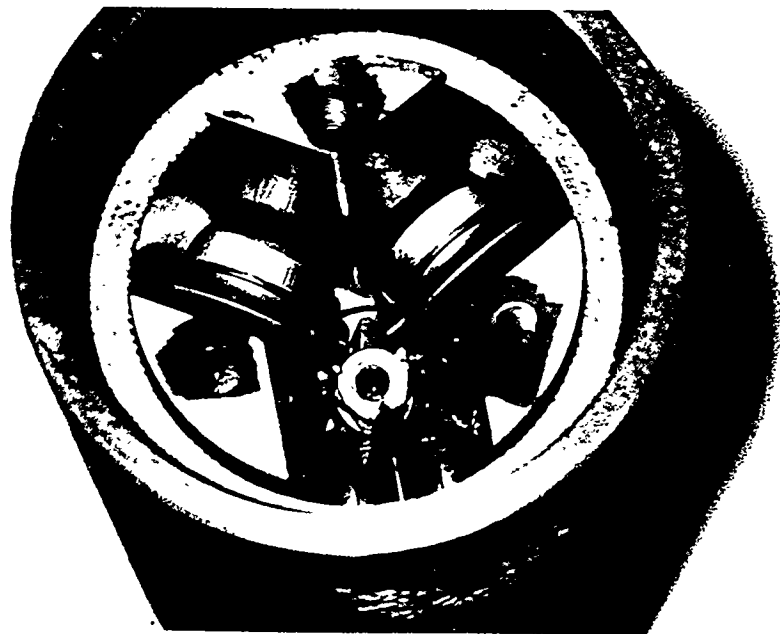
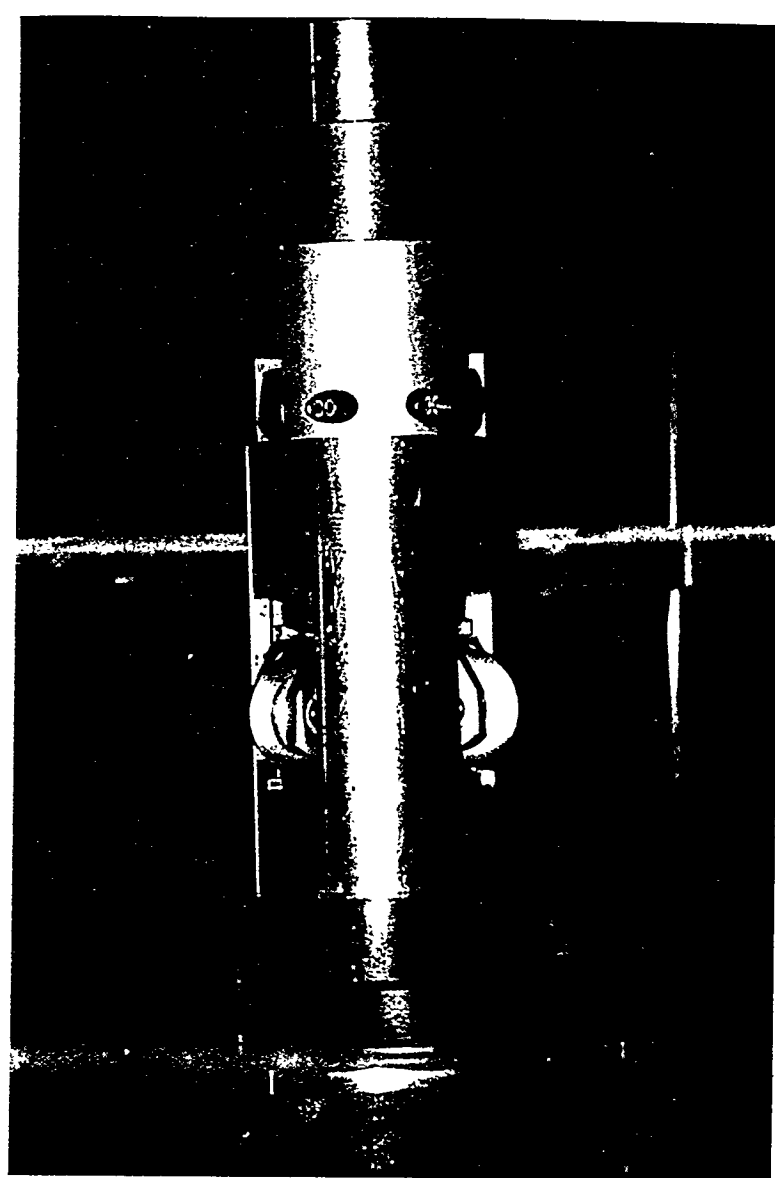
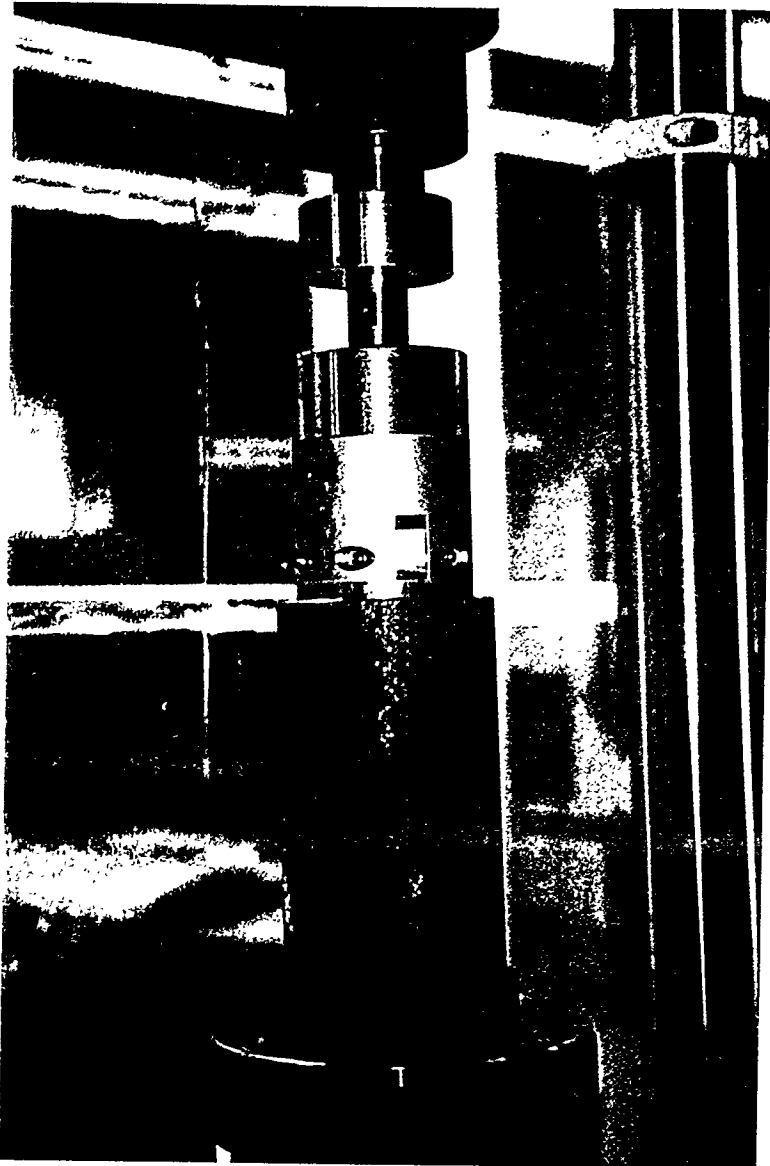

3. cutting wheels retracted
inside a 3.5"OD liner

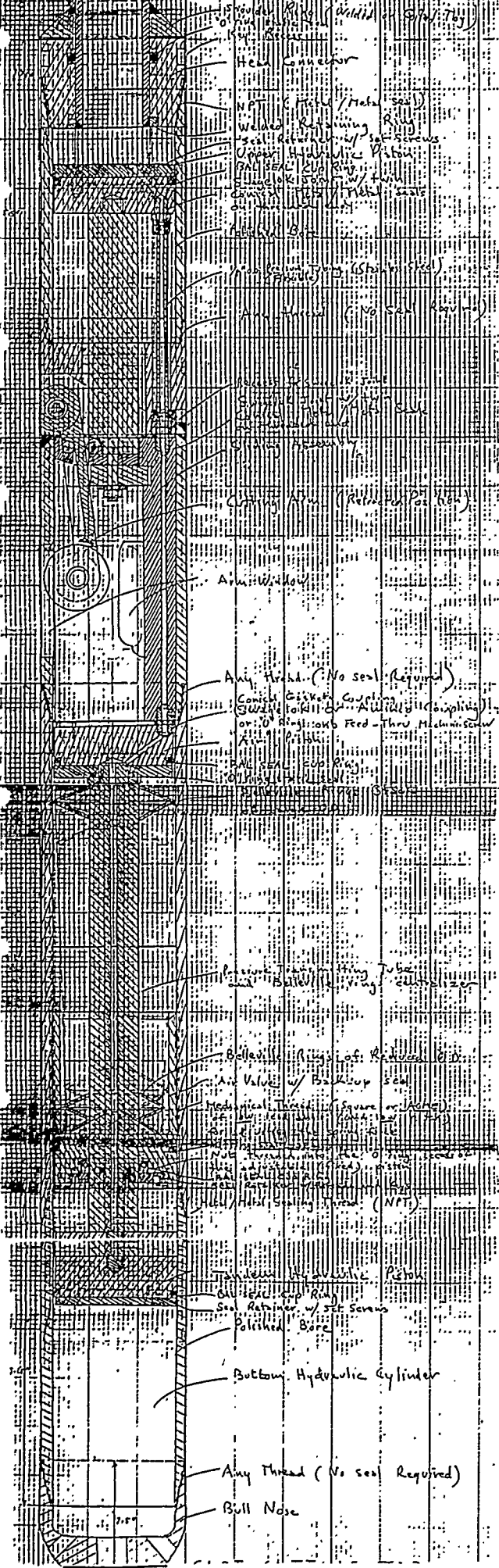

SLOT-CUTTING TOOL

Complete Assembly

FIG. 3
TOOL ASSEMBLY.

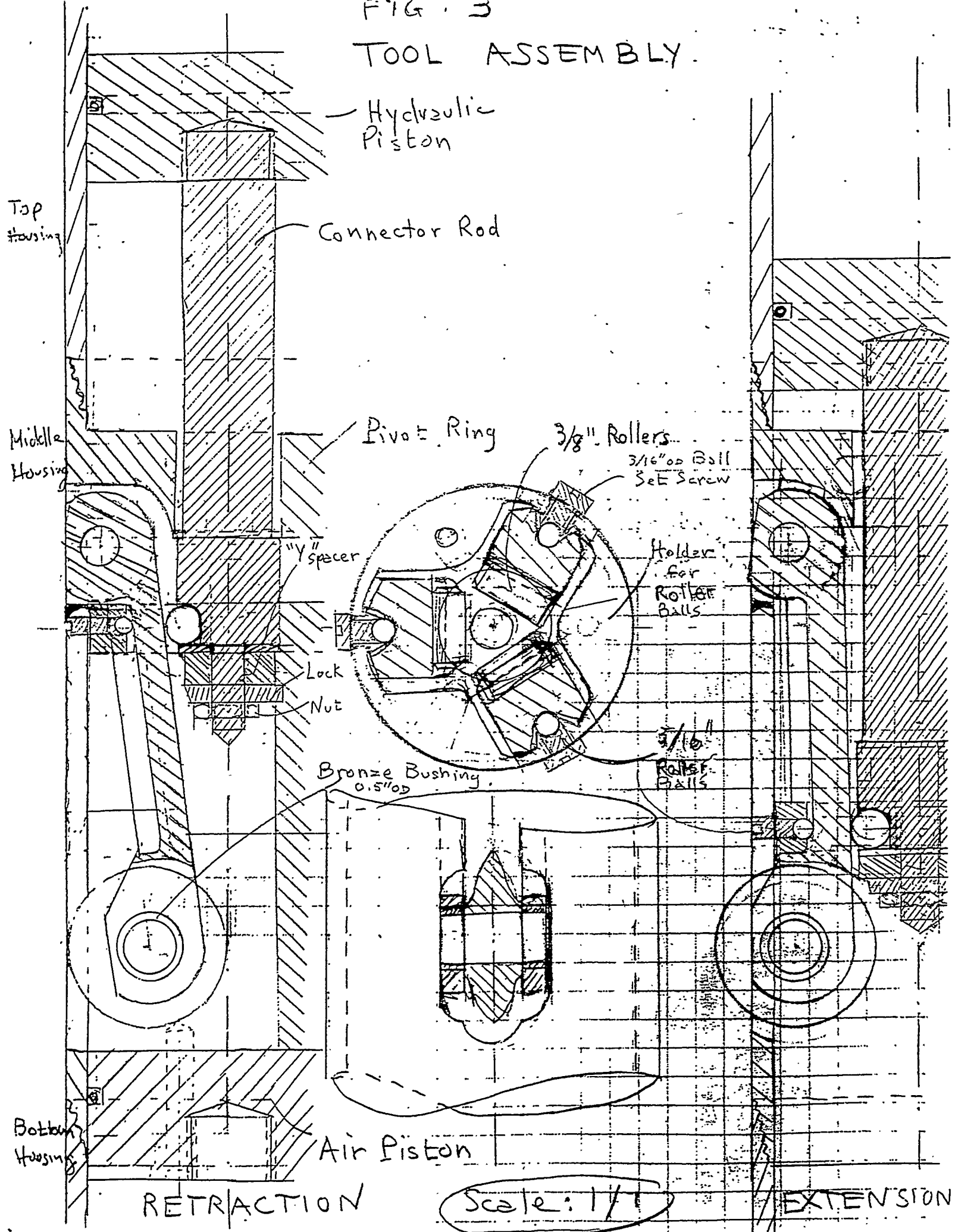

Hydraulic Piston

Top Housing

Connector Rod

Middle Housing

Pivot Ring

3/8" Rollers

3/16" OD Ball
Set Screw

1/2" spacer

Holder
for
Roller
Balls

Lock
Nut

3/16"
Roller
Ball

Bronze Bushing
0.5" OD

Bottom Housing

Air Piston

RETRACTION

Scale: 1/16"

EXTENSION

PIVOT RING (Middle Housing)

Material: Carbon Steel

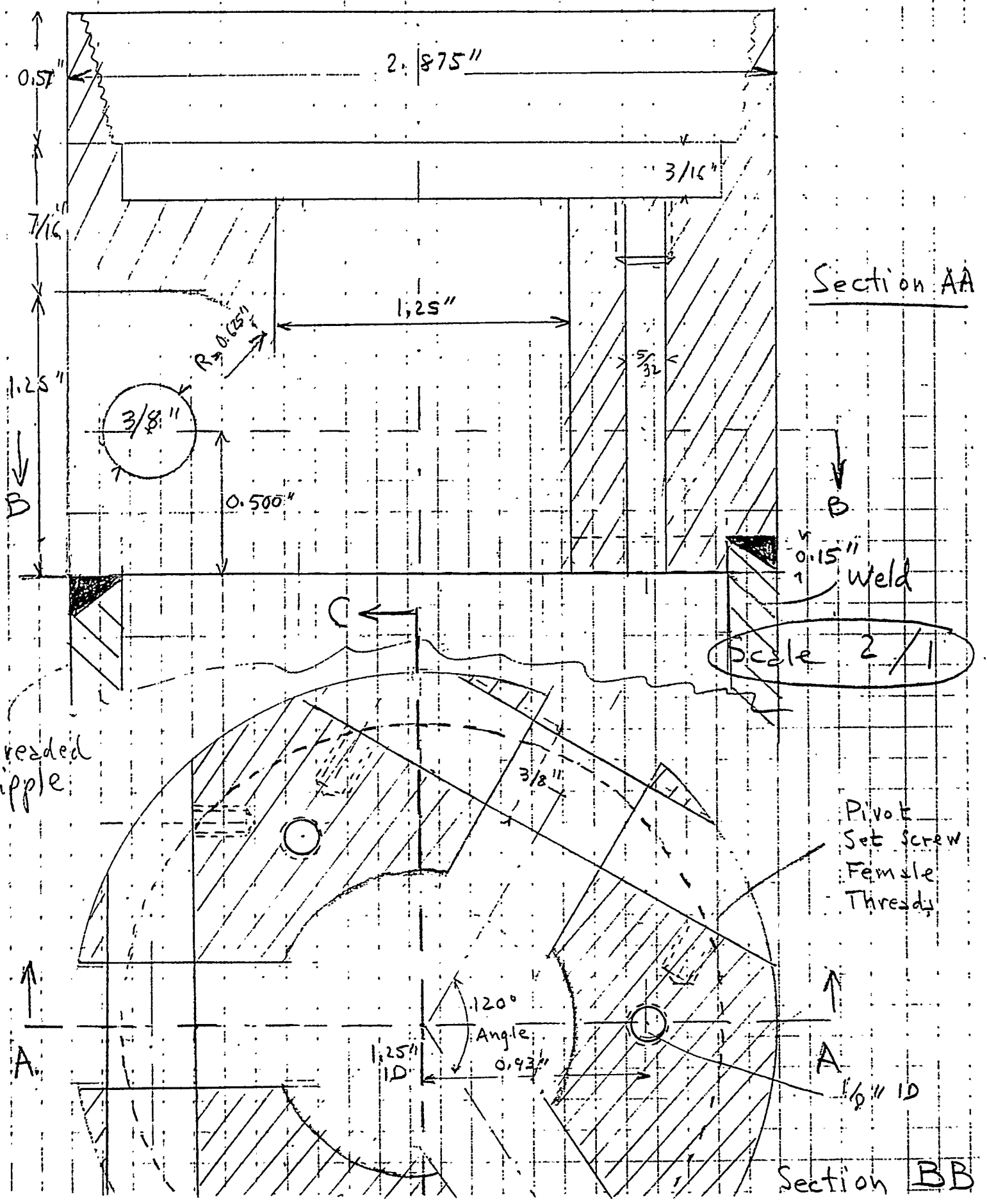

MIDDLE HOUSING (Bottom Threaded Nipple)

Sheet #2

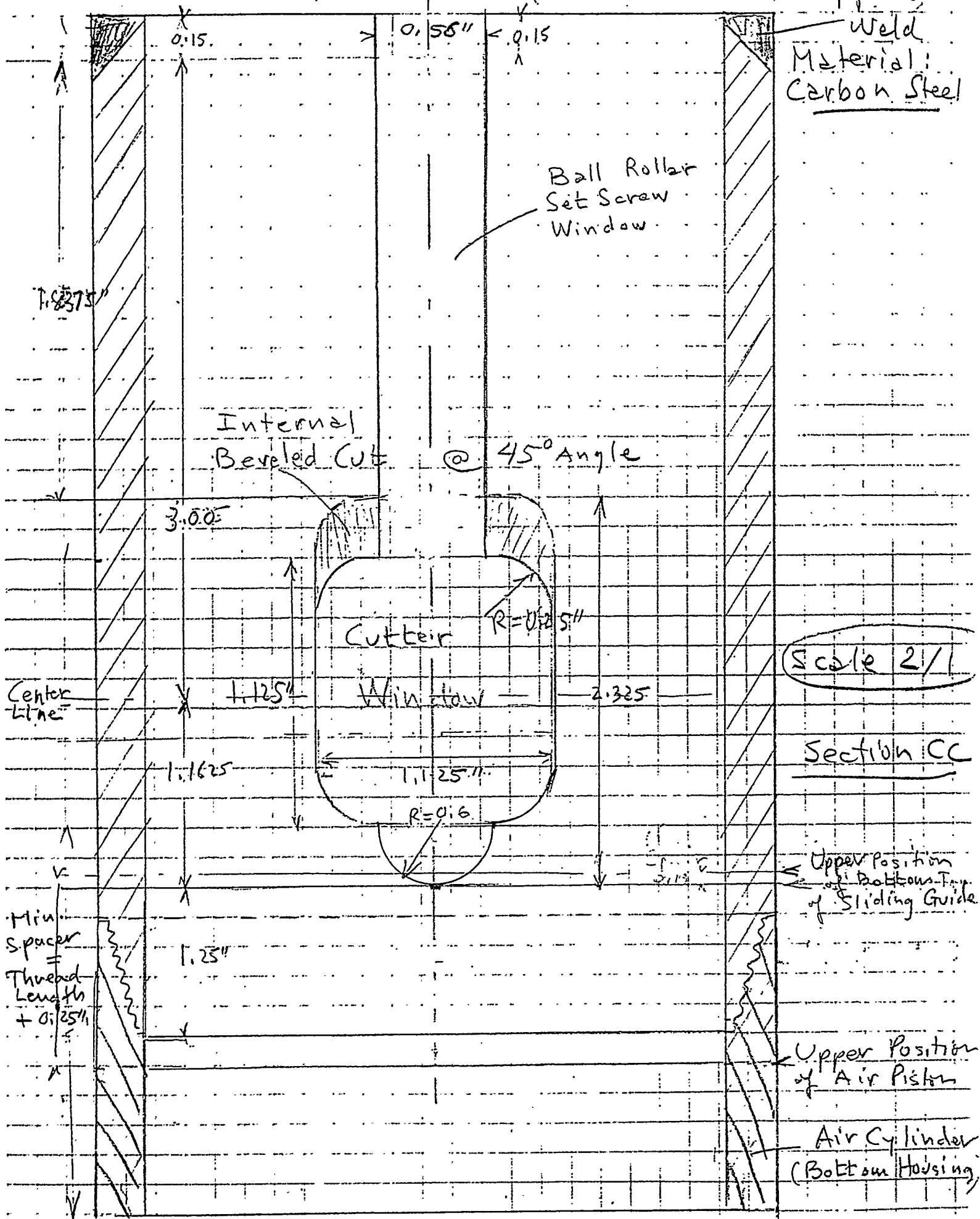

CUTTING ARM

Number: 3
Material: 18 Ni 300
(Manganese Steel)

3/8" O.D. shaft
(Manganese Steel)

Scale 2/1

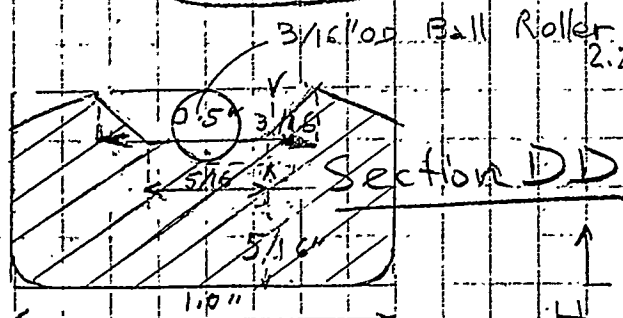

Section HH

Fork

1/2" O.D.
Bronze Bushing

3/8" O.D. shaft

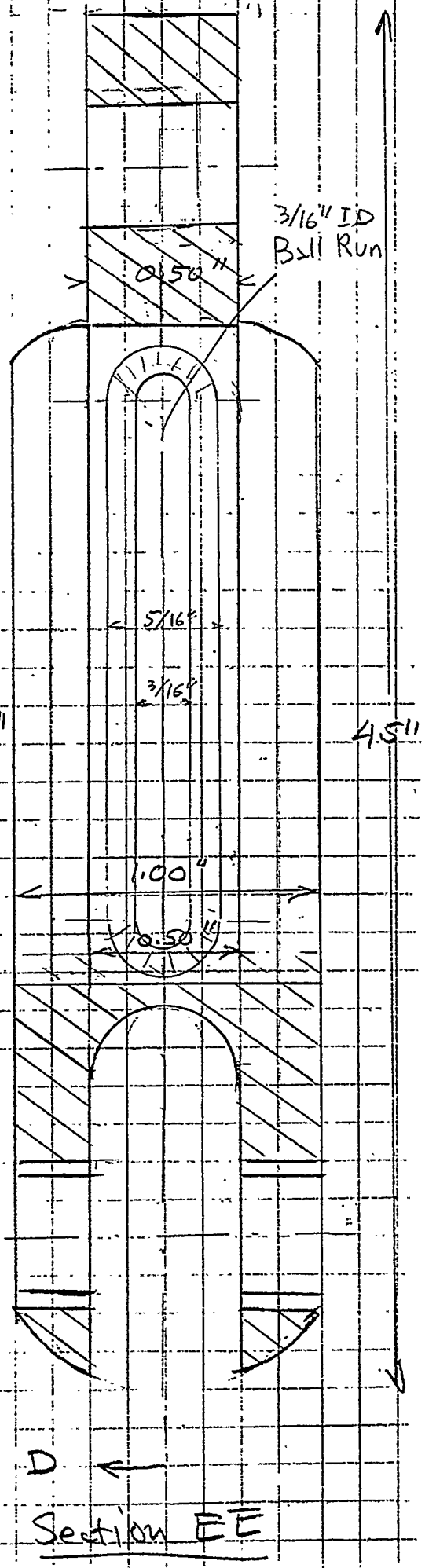
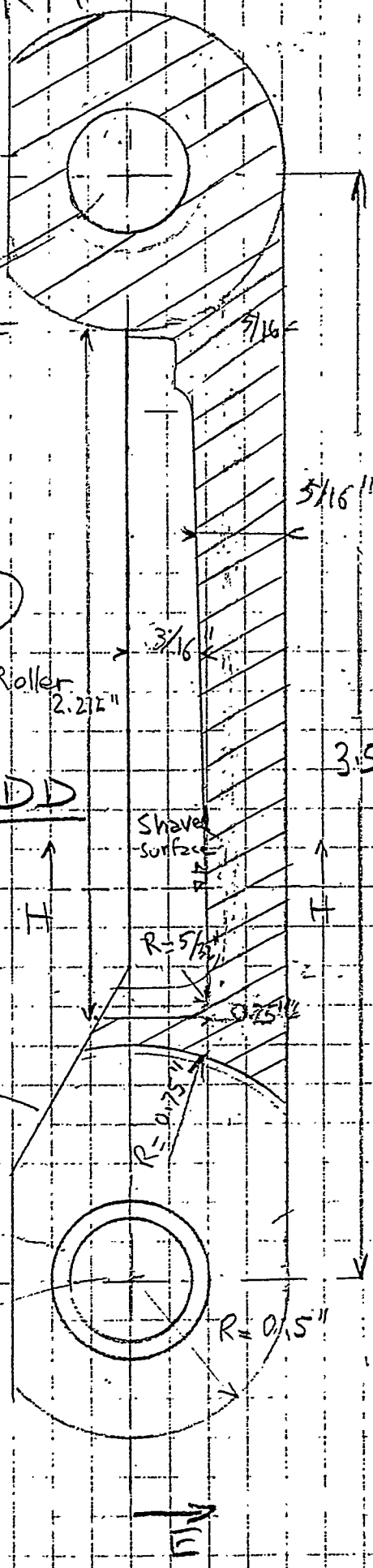

Section EE

CUTTING WHEEL / ROLLERS Sheet # 4

Number: 3 Material: 18 Ni 300

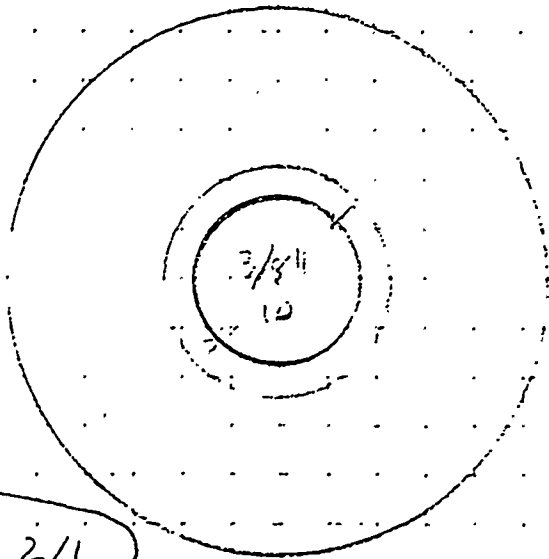

Scale: 2/1

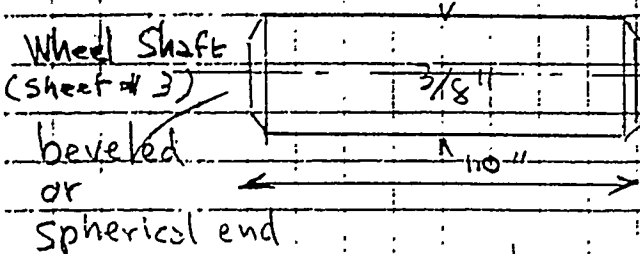
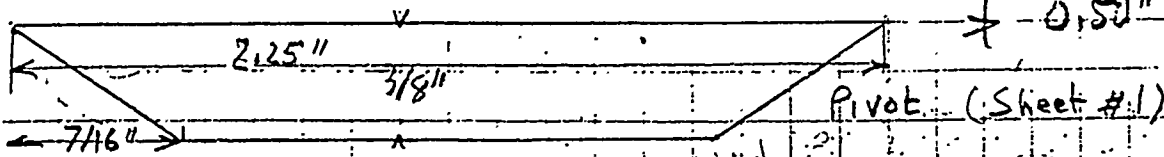
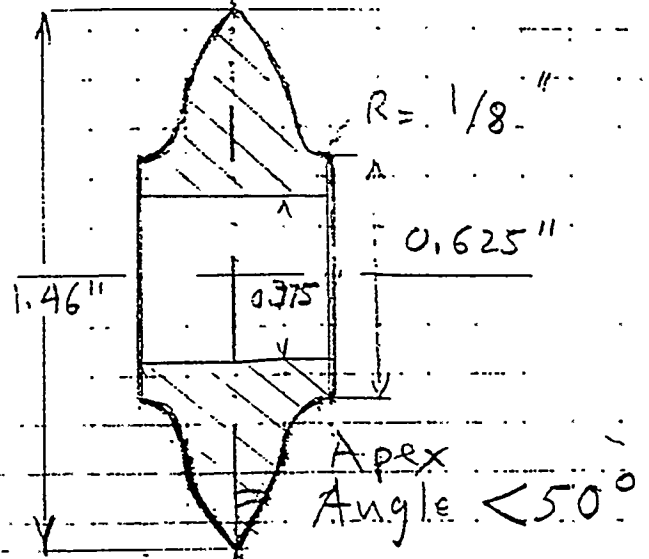

Number:
 (3) 3/8" x 1" Long Extension on Roller
 (3) 3/8" x 2.25" Plus (3) of 3/8" OD x " Long
 (Pivots) WHEEL PROFILE
 DETAIL

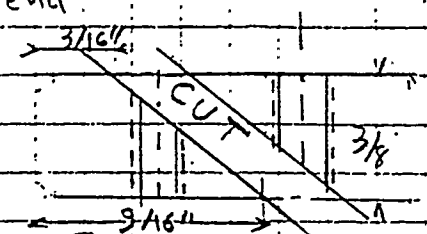

Beveled End of 3 Pivots
 Followed by drilling and
 Threading to match
 Set Screws on Sheet #1
 Extension Roller Number: 3

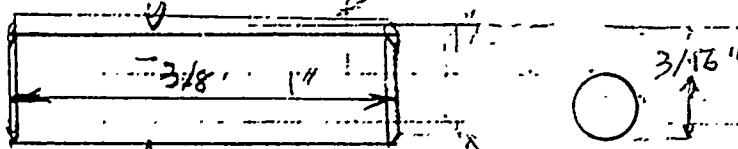
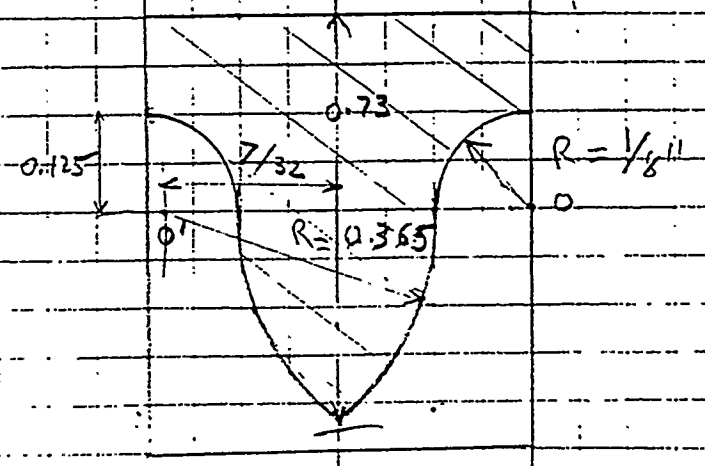

Retraction Ball - (Sheet #7)
 Number: (3)

Scale: 4/1

Scale: 2/1

SLIDING GUIDE (Bottom Part) Sheet # 5

Material: 18 Ni 300

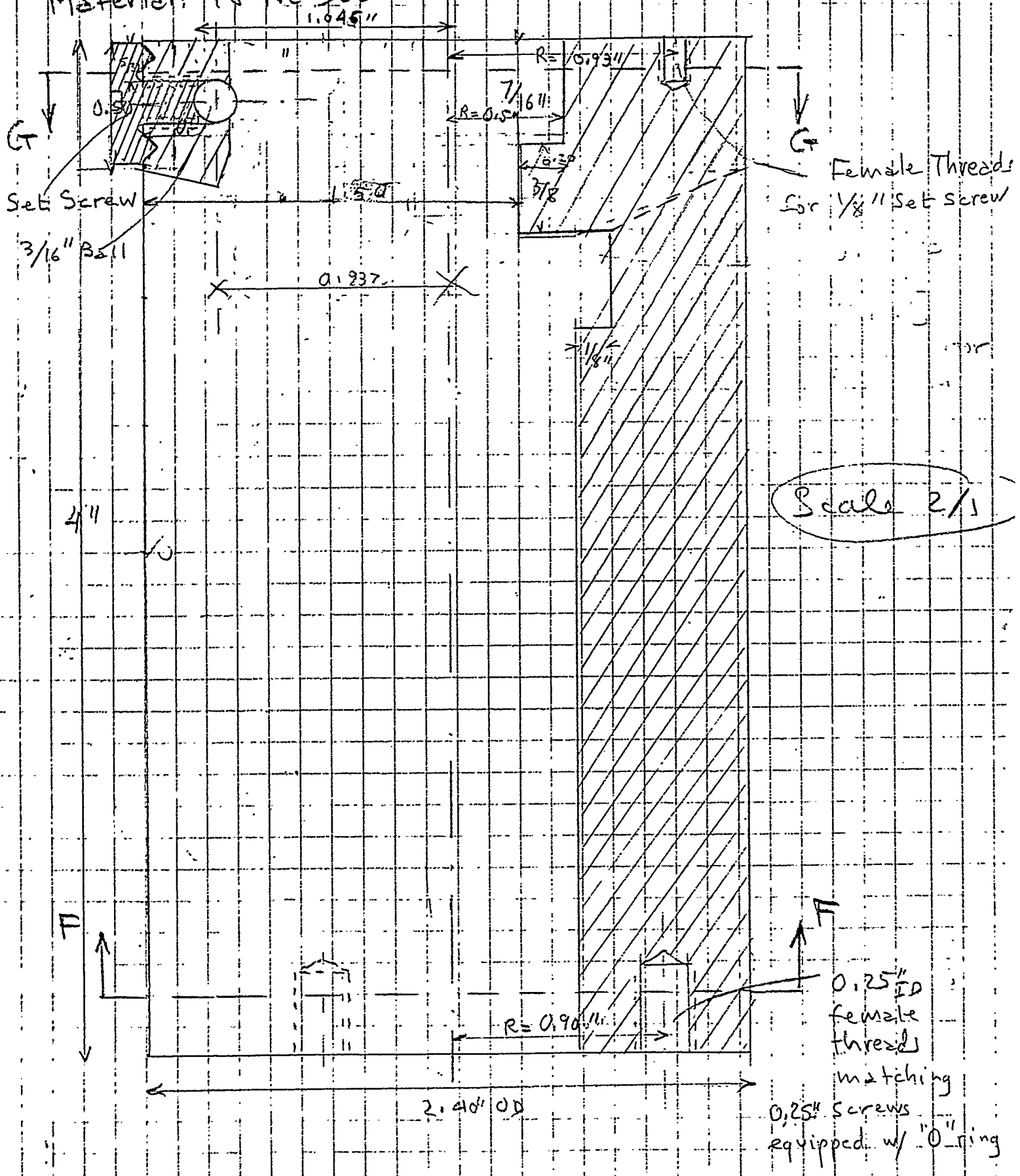

Female Threads
for 1/8" Set screw

Scale 2/1

0.25" ID
female
threads
matching
0.25" screws
equipped w/ O ring

2.40" OD

0.937

R=0.90"

R=0.54"

7/16"

1/8"

1/8"

4"

1/8"

0.50"

3/16" Ball

Set Screw

SLIDING GUIDE (Bottom Part) Sheet #6

Material: 18 Ni 300

SECTION FF

Scale 2/1

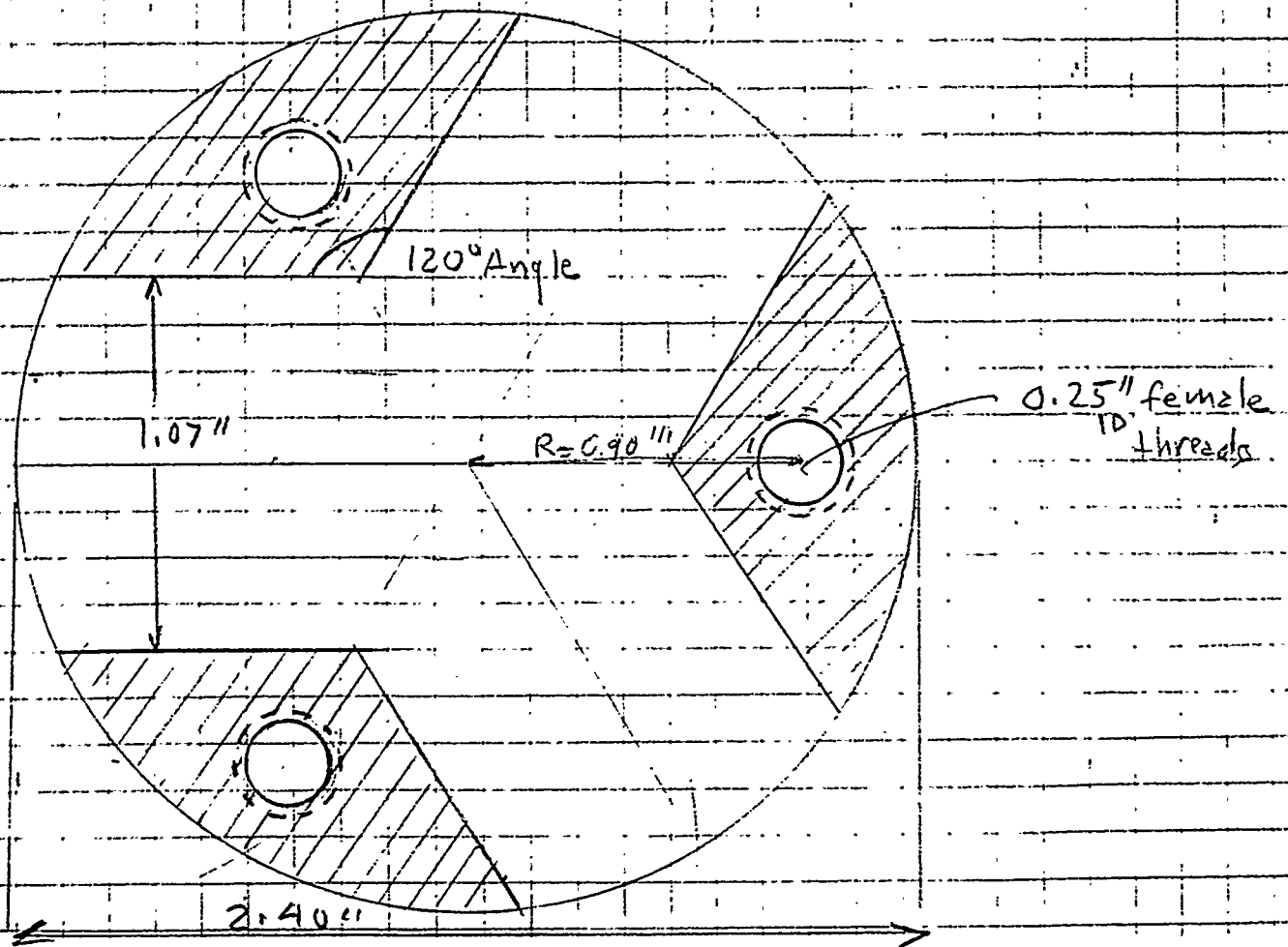

SLIDING GUIDE

Sheet #7 Rev.

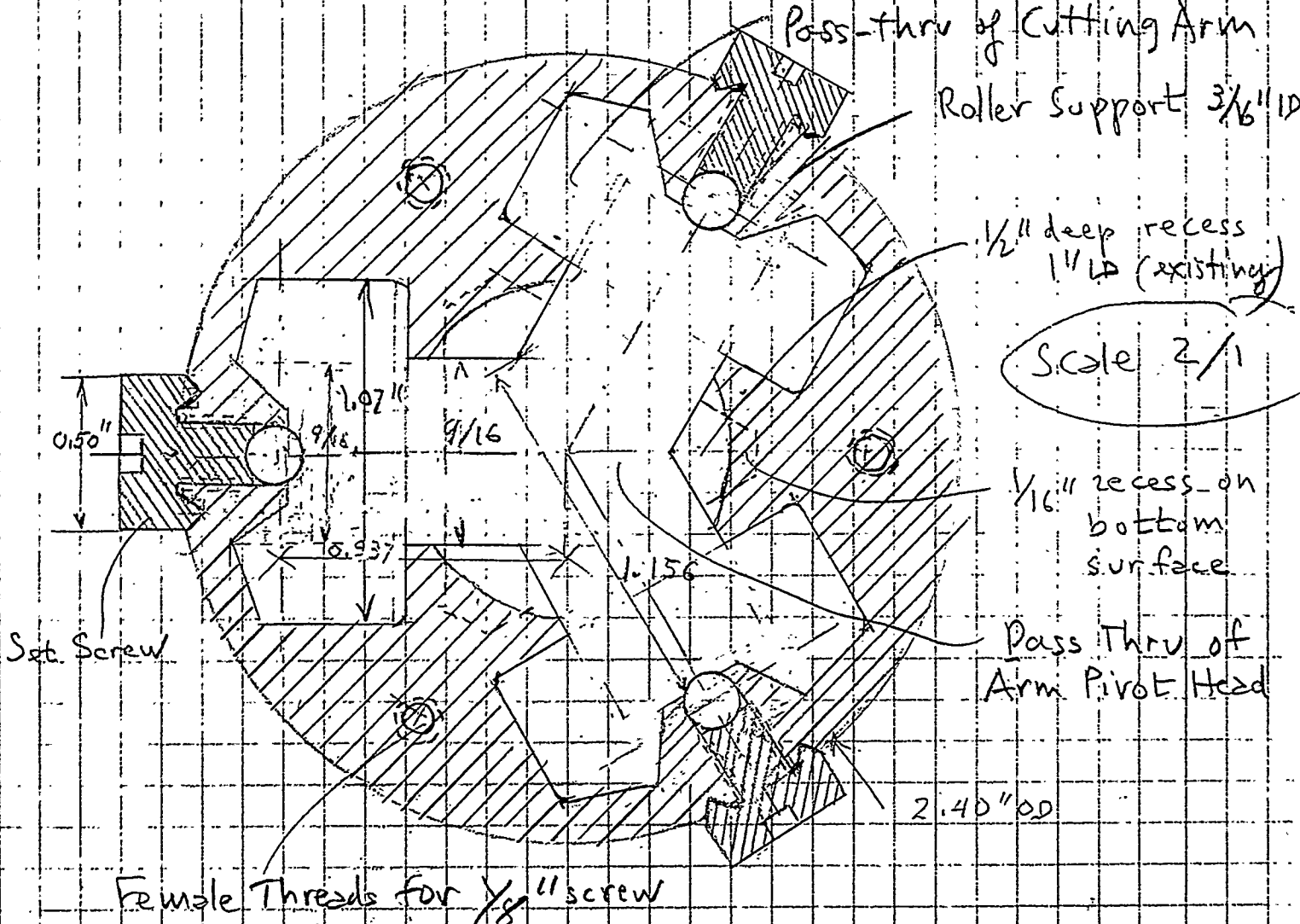

Bottom Plug

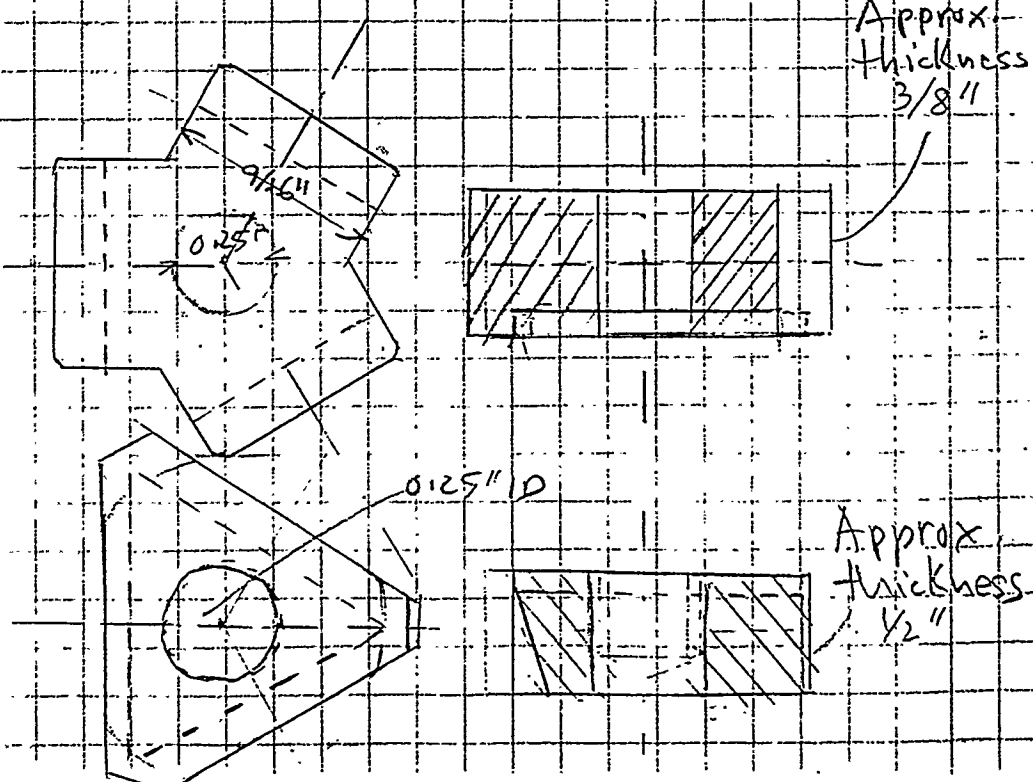

Approx. thickness 3/8"

Approx. thickness 1/2"

SLIDING GUIDE

(Middle Part)

Material: 18 Ni 300

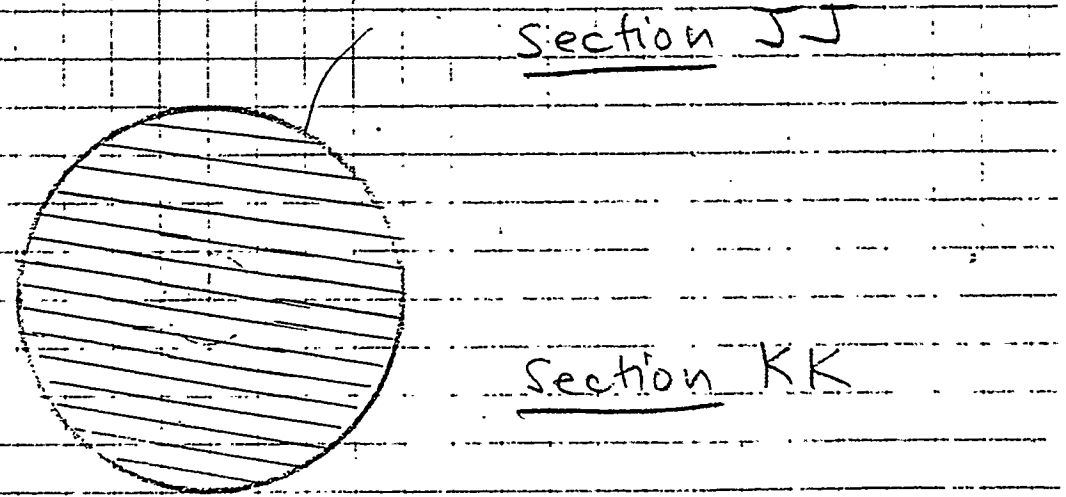
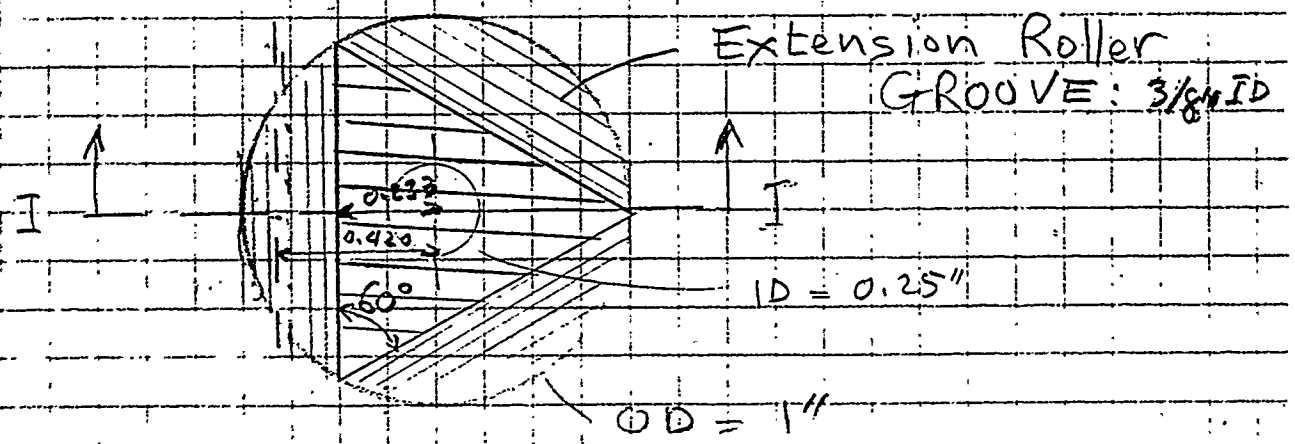
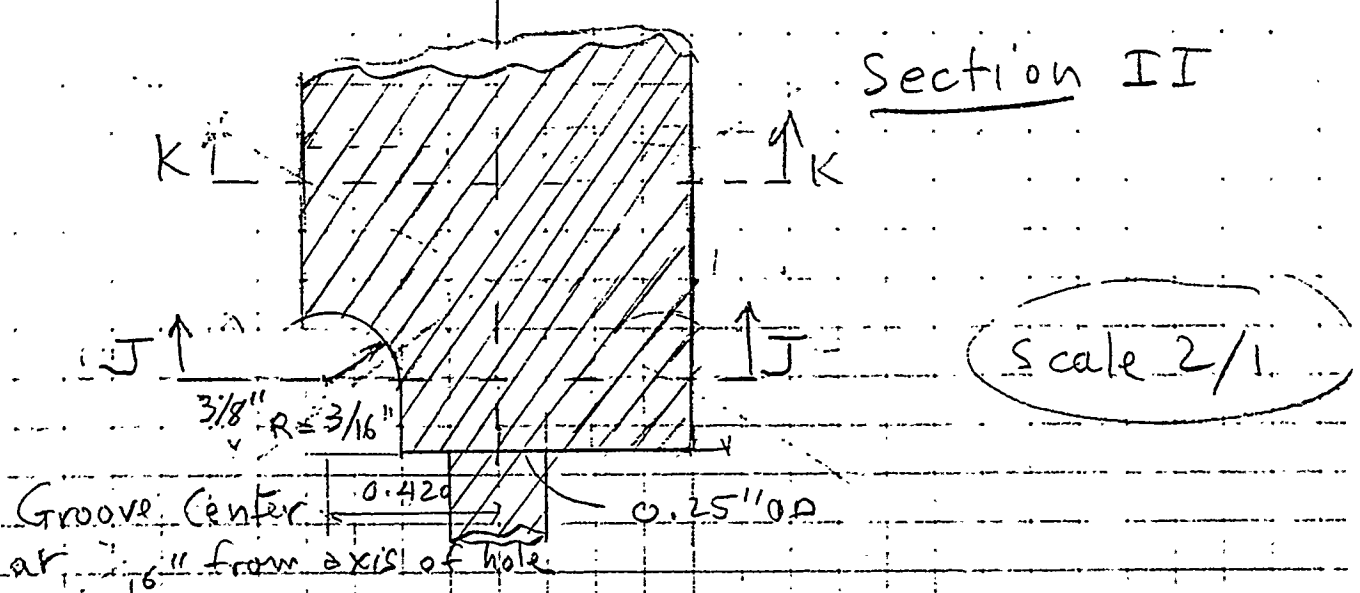

SLIDING GUIDE
CONNECTOR ROD
Material: 18 Ni 300

Number: 1

Bolt equipped w/ "O" Ring for
AIR PISTON ONLY

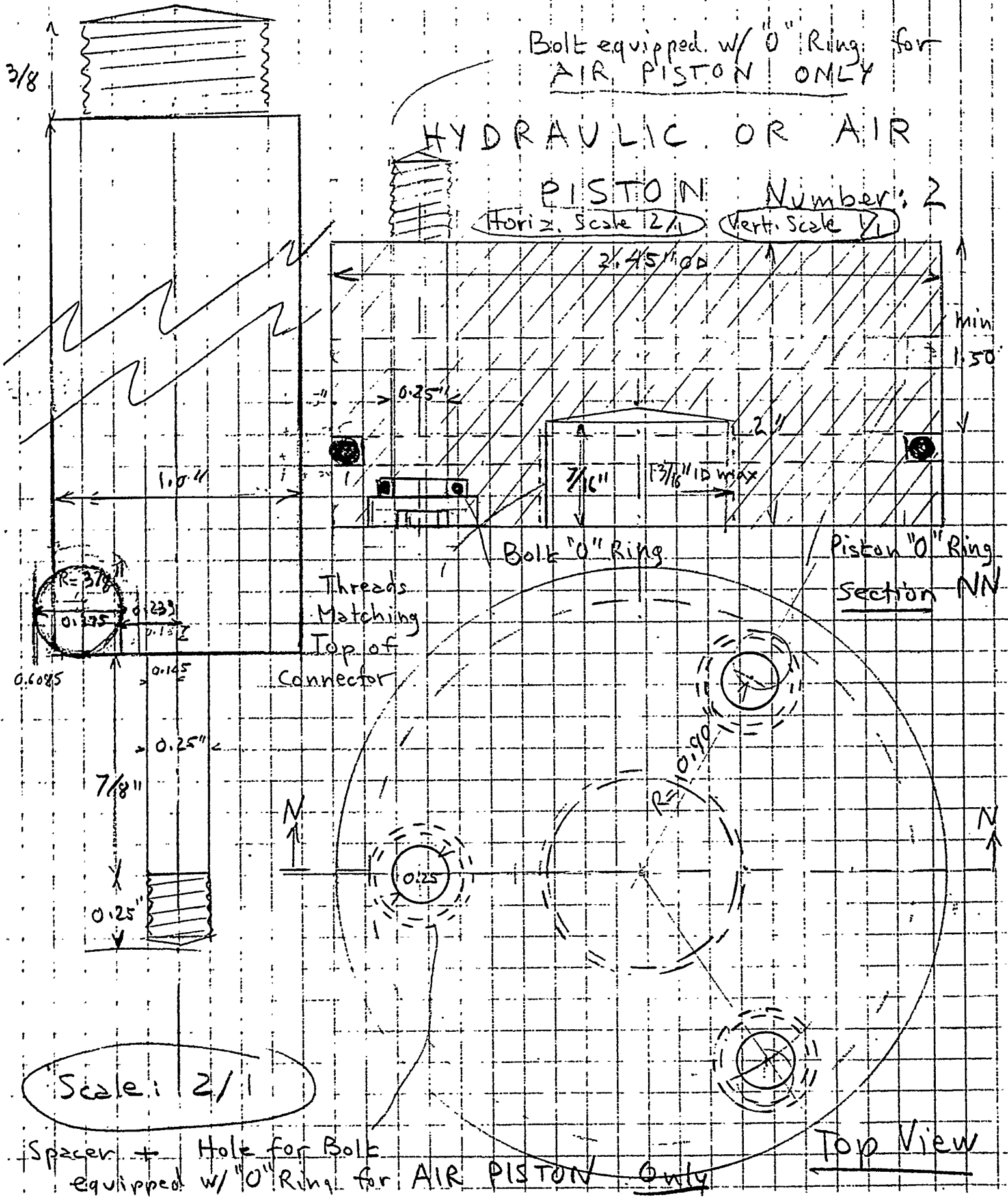

APPENDIX 2

DETAILED DRAWINGS AND PHOTOGRAPHS OF SPECIAL CASING JOINTS
(Tasks 1.2 and 1.6 Deliverables)

APPENDIX 2

DESIGN AND CONSTRUCTION OF SPECIAL CASING JOINTS (Tasks 1.2 and 1.6)

- Deliverables:
- a) 1 Upper Special Joint (USJ) of 11.75"OD Casing
 - b) 1 Top Lower Special Joint (TLSJ) of 11.75"OD casing
 - c) 1 Bottom Lower Special Joint (BLSJ) of 10.75"OD Casing
 - d) 1 "H" Joint connecting the twin drainholes to the Steam tubing and to the Downhole Oil Separator/sump

Item a) USJ and couplings

- Functions:
- 1) To provide access of the drill string and of well tubulars to the drainholes or to the Oil Separator/sump
 - 2) To assemble together the Special Joints,
 - 3) To link the Special Joints to the remainder of the 10.76"OD casing string.

- Specifications:
- 30 ft jt 11.75"OD Steel Casing 42 lb/ft API grade H40
 - 1 Box Ventura Threads, 1 Pin Ventura Threads
 - 1 10.75" Casing Coupling (Box/Box API Short 8 round)
 - 1 11.75" Casing Coupling (Box/Box Ventura Right threads)
 - 1 11.75" Casing Coupling Left Threads API 8 round

Internals: None

Suppliers: Bakersfield Pipe Supply Co.
E.M.Jorgensen Pipe Supply
UC-Berkeley Machine Shop
O'Brien Engineering and Shop

Item b) TLSJ

- Functions:
- 1) to provide access of the drill string to the twin drainholes
 - 2) to provide receptacles for a 2.875"OD production tubing, a 2.375"OD auxiliary production tubing, multiple flow connections with the BLSJ and access for periodic clean-up of the Downhole Oil Separator/Sump with coiled tubing.
 - 3) to provide sealed connections with 4" curved liners and an anchored base to two PBR's leading to the completed twin drainholes
 - 4) to provide the top part of the Downhole Separator/Sump

Internals: Four pipes (1 5.5"OD curved channel, 1 straight channel, 2 receptacles (3.5"OD and 2.875"OD respectively, connected by a Y at their lower ends, for Oil Well / Omniferous Pump, all API K 55
1 fixed Bottom Plate 2" thick
1 Floating Top Plate 2" thick

Specifications: 34 ft jt of 11.75"OD 42 lb/ft H 40 Steel Casing
w/ Box x Pin Ventura Right Threads
5.5"OD pipe bent at 320' radius

Suppliers: Bakersfield Pipe Supply Co.
Pacific Pipe Supply Co.
Bayshore Metals
Ron's Machine Shop
O'Brien Engineering and Shop
Rico's Welding
Cal Steam Co.
U Save Equipment rental
Caldwell
Rafael Lumber
Whole Earth Access tools and supply
San Francisco Electrical Co.

Item 3) BLSJ

Functions: 1) To provide access to the lower drainhole
2) To provide access to the cementing shoe and plug
retainer
3) To constitute the Bottom portion of the Oil Separator

Internals: 1 5.5"OD curved channel 15.5 lb/ft API K 55
1 2.875"OD partial tubing API K 55 and welded connections
1 fixed plate 2" thick
1 floating plate 2" thick and welded connecting "O" ring
sealed 6"OD pipe and 2.875"OD guide

Specifications: 30 ft jt 10.75"OD 40.5 lb/ft API H 40 steel
w/ pin x pin short API 8 round threads
5.5"OD bent pipe at 300' radius

Suppliers: Bakersfield Pipe Supply Co
Ron's Machine Shop
O'Brien Engineering and Shop
Rico's Welding

Item d) "H" Joint

Functions: 1) To link the 3-way Steam Valve to the Twin Drainholes
Annuli
2) To link the twin drainholes to the Oil Separator/Sump
3) To carry the wireline transferable plug
4) To convey the production stream to the Oil
Separator/Sump by gravity
5) To vent lift steam and produced gases to the casing
annulus at near atmospheric pressure

Specifications: 4.5"OD vertical Body Sides, connected by 3 welded
vertical plates and 3 horizontal welded plates
Four 4"OD Branches

Suppliers: Bakersfield Pipe Supply Co
Rico's Welding
Bayshore Metals
OTIS Engineering

2 OTIS X 4.5"OD Landing Nipples

CONSTRUCTION METHOD

Item a) requires only machining and welding. Couplings are made by welding together the pre-threaded elements.

Items b) and c) are built like tubular heat exchangers allowing free thermal expansion of all internals. The End Plates are similar to tube sheets in a heat exchanger.

The first step is to cut a window in the vertical casing joint, the second step is to insert the curved tubing, the third step is to weld one end plate to the internals. All internals and plates are designed to be pulled in and out of the vertical casing for welding each plate to the internals outside the casing. The assemblies are pulled inside to reach their final positions, prior to welding the fixed plate to the casing and prior to welding the curved channel to the window's edge. These sliding displacements of the internals are made by chain pulling against temporary frames welded to the thread protectors of the casing.

Item d) requires some machining, cutting and mostly welding of pre-cut elements.

Most of the cuts are made with Oxy-cutting torches. They are ground smooth and bevelled prior to welding, following specified welding procedures aimed at minimizing heat distortion.

All welds include a root pass followed by a fill-up pass, to achieve full penetration and a complete seal.

All welding rods are shielded with appropriate Oxide coatings.

All operations were performed under the direct supervision of the Principal Investigator.

Due to the heavy weight of pipes and internals, a rented fork lift was used to handle them.

Some of the smaller tubulars were pulled with an electric winch, also rented.

SUGGESTED PROCEDURE FOR MACHINING REQUESTED PLATES.

1) Start from hot-rolled 2"-thick Low-Carbon steel plate material, cut into four squares of 13.25" side

2) Grind-off any burrs on the edges, resulting from the cutting operation

3) Clamp all four plates into an 8" stack and grind-off the edge surfaces on 3 sides straight and square, to be used as reference surfaces in a CNC milling machine. I assume the finished width to be 13" between the two parallel reference sides. If your supplier requires more than + or - 0.125" tolerance for his operation of flame-cutting, increase the stock plates size accordingly. I also assume the end mill OD to be 0.5" or larger.

4) For the TLSJ Top plate (Sheets 1 and 2), positioned with center in ' (y = 6.5 , x = 6.5), cut the following circular grooves with an end mill:

- 0.5" deep, center O (y= 9.1875", x = 6.5) OD = 5.5" - 0, + 0.005
- 1.6" deep, center O OD = 5.0" id.
- 0.5" deep, center O' (y = 3.8125, x = 6.5) OD = 5.5" id.
- 1.6" deep, center O' OD = 5.0 id.
- 0.5" deep, center ' y = 6.5, x = 2.85" OD = 3.50 id.
- 1.6" deep, center ' OD = 3.07 id.
- 0.5" deep, center C y = 7.6875, x = 10.375 OD = 2.875 id.
- 1.6" deep, center C OD = 2.44 id.
- 0.5" deep, center D y = 10.25, x = 5.125 OD = 1.90 id.
- 1.9" deep, center D OD = 1.65 id.
- 1.9" deep, center E y = 3.8125, x = 2.875 OD = 1.50 id.
- 1.9" deep, center ' y = 6.5, x = 6.5 ID = 10.8 - 0.0005, +0

5) Reverse the plate and cut the following circular grooves:

- 0.5" deep, center O y= 9.1875, x = 6.5 OD = 5.5" -0, +0.005
- 0.5" deep, center O' y = 3.8125, x = 6.5 OD = 5.5 id.
- 0.5" deep, center ' y = 6.5, x = 2.85 OD = 3.5 id.
- 0.5" deep, center C y = 7.6875, x = 10.375 OD = 2.875 id.
- 0.1" deep, center D y = 10.25, x = 5.125 OD = 1.90 id.
- 0.1" deep, center E y = 3.8125, x = 2.875 OD = 1.50 id.
- 0.1" deep, center ' y = 6.5, x = 6.5 ID = 10.8 - 0.005, + 0

This completes the first plate. Keep the remainder of the square plate for future use. Discard the plugs.

6) For the Bottom plate of TLSJ (sheets 3 and 4), positioned with center ' at 6.5, 6.5, cut the following circular grooves:

- 0.5" deep, center O' (3.8125, 6.5) OD = 5.5 - 0, + 0.005
- 1.9" deep, center O' OD = 5.0 id.
- 0.5" deep, center F (6.5, 2.5) OD = 2.875 id.
- 1.9" deep, center F OD = 2.375 id.
- 1.9" deep, center I (6.5, 3.375) OD = 2.937 id.
- 1.9" deep, center ' (6.5, 6.5) ID = 10.8 - 0.005, + 0

7) Reverse the plate and, keeping the same position for ' , cut the following circular grooves:

- 0.75" deep, center W' (9.1875, 6.375) OD = 6.0 -0, + 0.005
- 0.25" deep, center W' OD = 6.5 id.
- 0.1" deep, center F (6.5, 2.5) OD = 2.875 id.
- 0.1" deep, center I (6.5, 3.375) OD = 2.937 id.

- 0.1 deep, center Ω' (6.5,6.5) ID = 10.8 -0.005,+0
- 8) Manually grind the transition from 5"ID to about 5.5"ID to round-off the lower edge of the central ring (OPTIONAL). This can be done later by the Welder.

This completes the second plate. Keep the remainder of the square plate, discard the plugs.

- 9) For the Top plate of the BLSJ (sheet 5) positioned with center Ω' at 6.5,6.5, cut the following circular grooves:
 - 0.5 deep, center ω (9.1875,6.375) OD = 6.0 -0,+0.005
 - 0.5 deep, center I (6.5,3.375) OD = 2.875 id.
 - 1.9 deep, center I OD = 2.375 id.
 - 1.6 deep, center ω'' (8.6875,6.20) OD = 5.0 id.
 - 1.9 deep, center Ω' (6.5,6.5) ID = 10.8 -0,+0.005

- 10) Reverse the plate and reposition Ω' . Cut the following circular grooves:
 - 0.5 deep, center ω'' (8.6875,6.20) OD = 5.5 -0,+0.005
 - 0.1 deep, center I (6.5,3.375) OD = 2.375 id.
 - 0.1 deep, center Ω' (6.5,6.5) ID = 10.8 -0,+0.005

This completes the third plate. Keep the remainder of the square plate.

- 11) For the BSLJ Bottom plate, position the plate and cut the following end mill grooves:
 - 1.9 deep, center Ω'' (7.0,7.0) OD = 3.625 -0,+0.005
 - 1.9 deep, center Ω'' ID = 9.80 - 0.005 +0

- 12) Reverse the plate and reposition Ω' . Cut the following grooves:
 - 0.1 deep, center Ω'' (7.0,7.0) OD = 3.625 -0,+0.005
 - 0.1 deep, center Ω'' ID = 9.80 -0.005,+0

This completes the fourth plate. Keep the remainder of the square plate.

PHOTOGRAPHS OF SPECIAL CASING
JOINTS CONSTRUCTION YARD
1. USJ and BSLJ completed

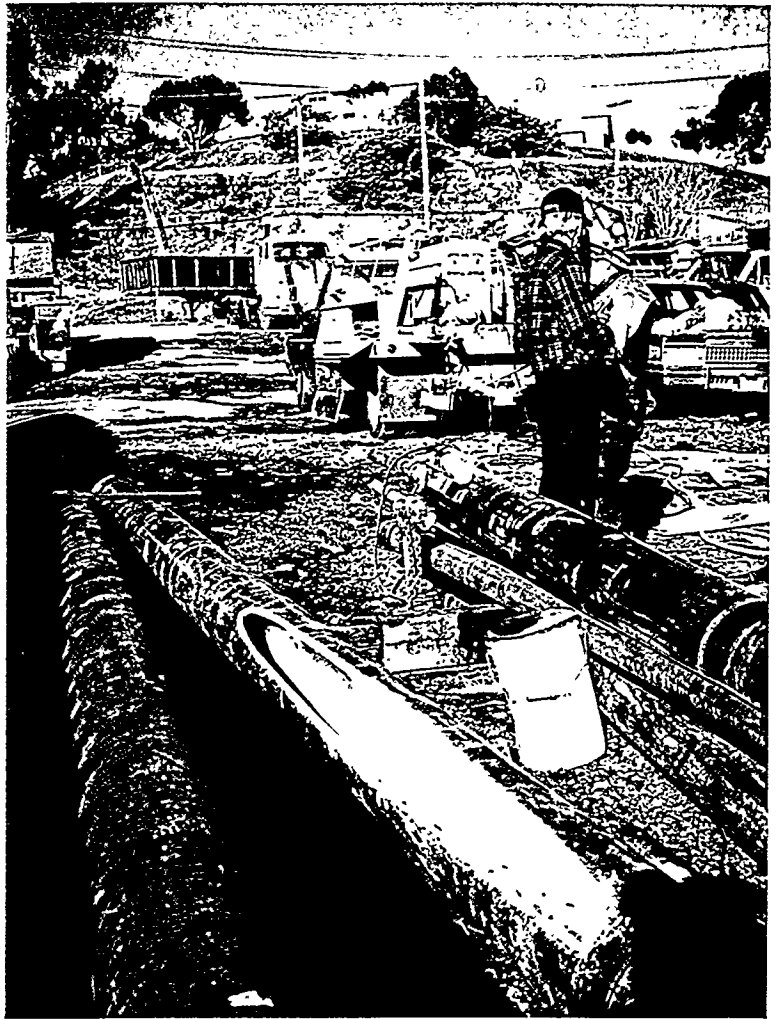

2. TSLJ under construction



PHOTOGRAPHS OF DETAILS OF
SPECIAL CASING JOINTS
1. BLSJ window and flow connection
to casing shoe

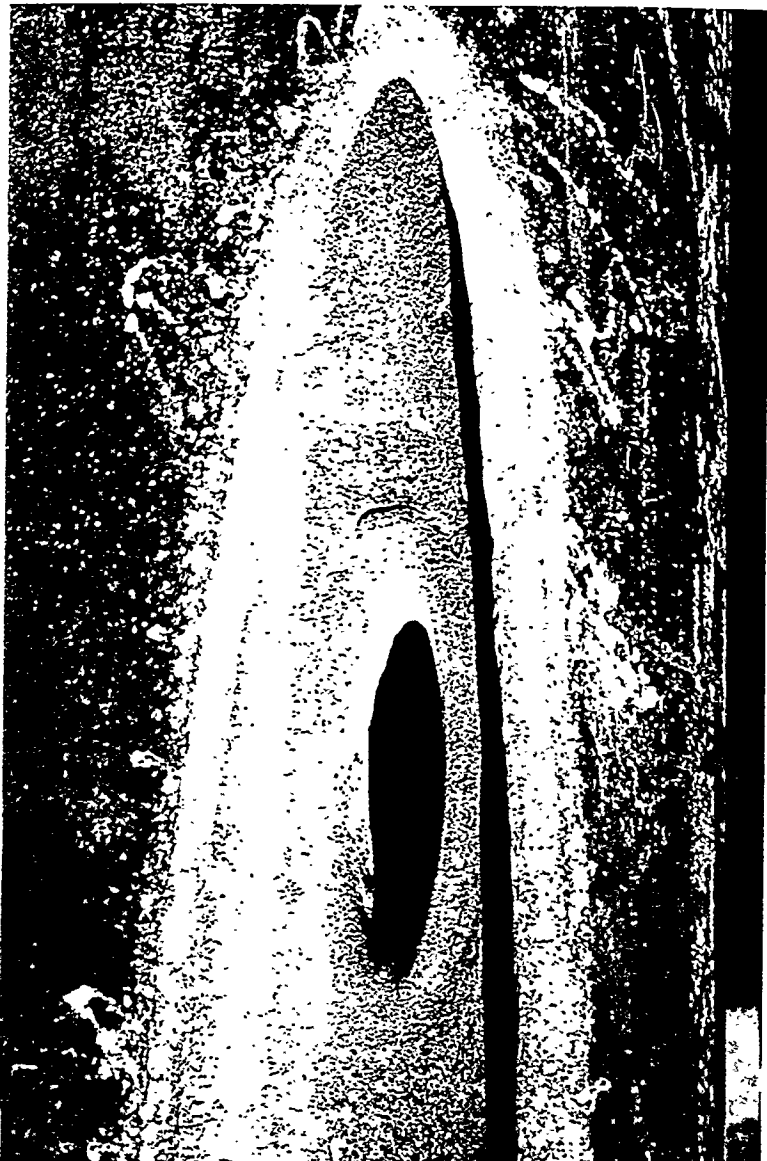

2. welded bottom plate BLSJ

PHOTOGRAPHS OF DETAILS OF
SPECIAL CASING JOINTS
1. TLSJ Top

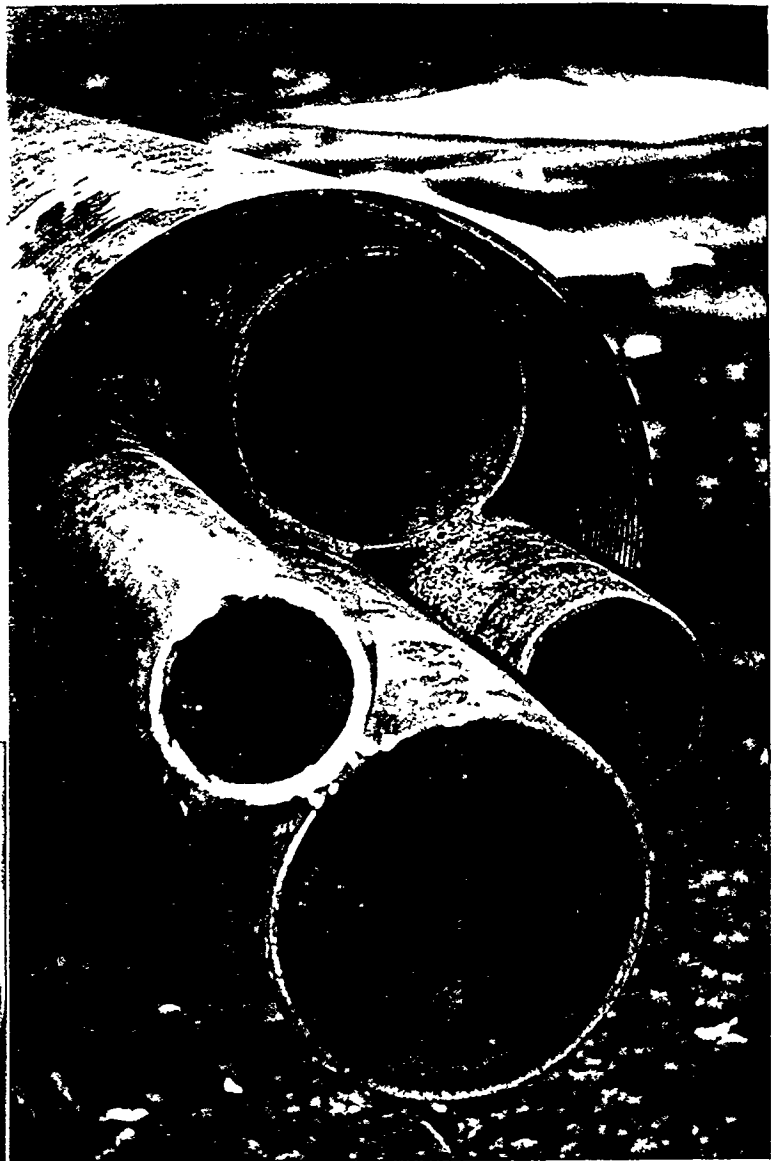

2. welded bottom plate TLSJ
(before insertion)

MODIFIED 3/31/95

SHEET NO 2 OF 3

FILE DOE/ETA

DATE 11/10/94

BY MG

REVISED

TOP LOWER Special Joint (TLSJ) TOP PLATE

TOP VIEW (Surface CC of Sheet 3)

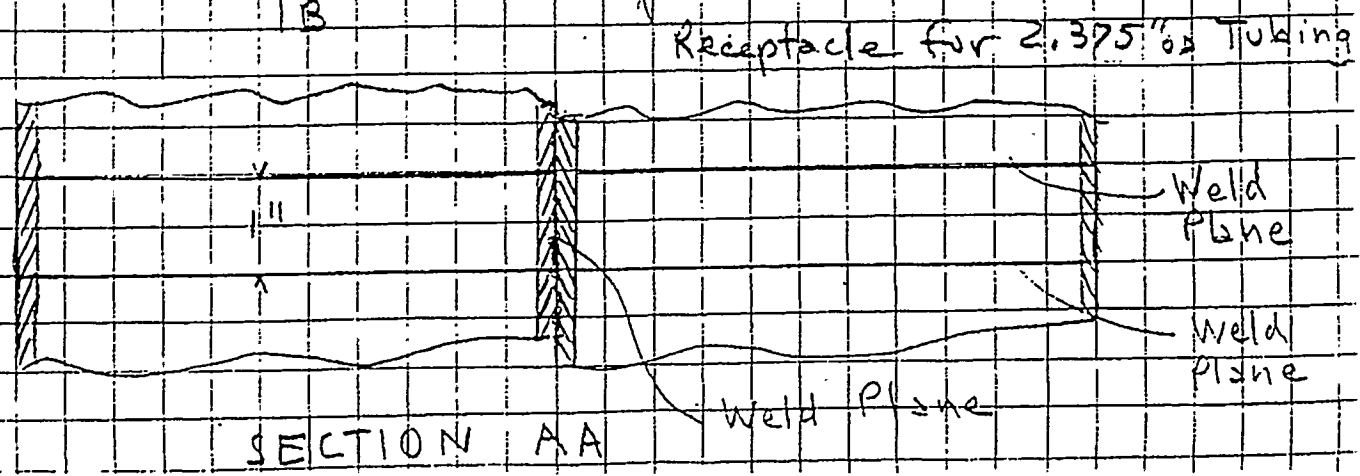
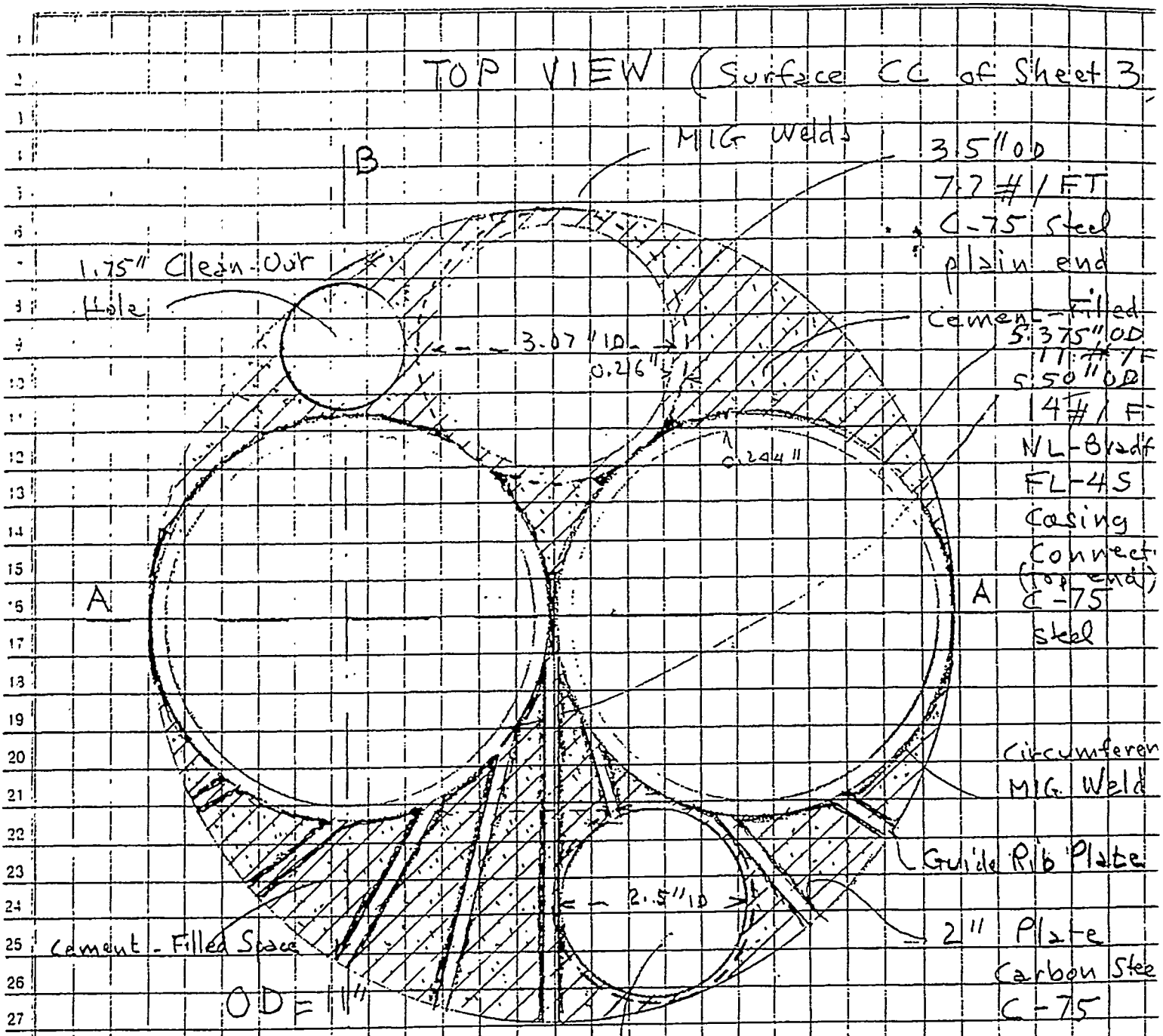

SECTION A-A

MODIFIED 3/31/93

FILE DOE/ETA/P

SUBJECT

TLSJ - TOP PLATE
Cross-Section BB

DATE 11/10/94

BY MG

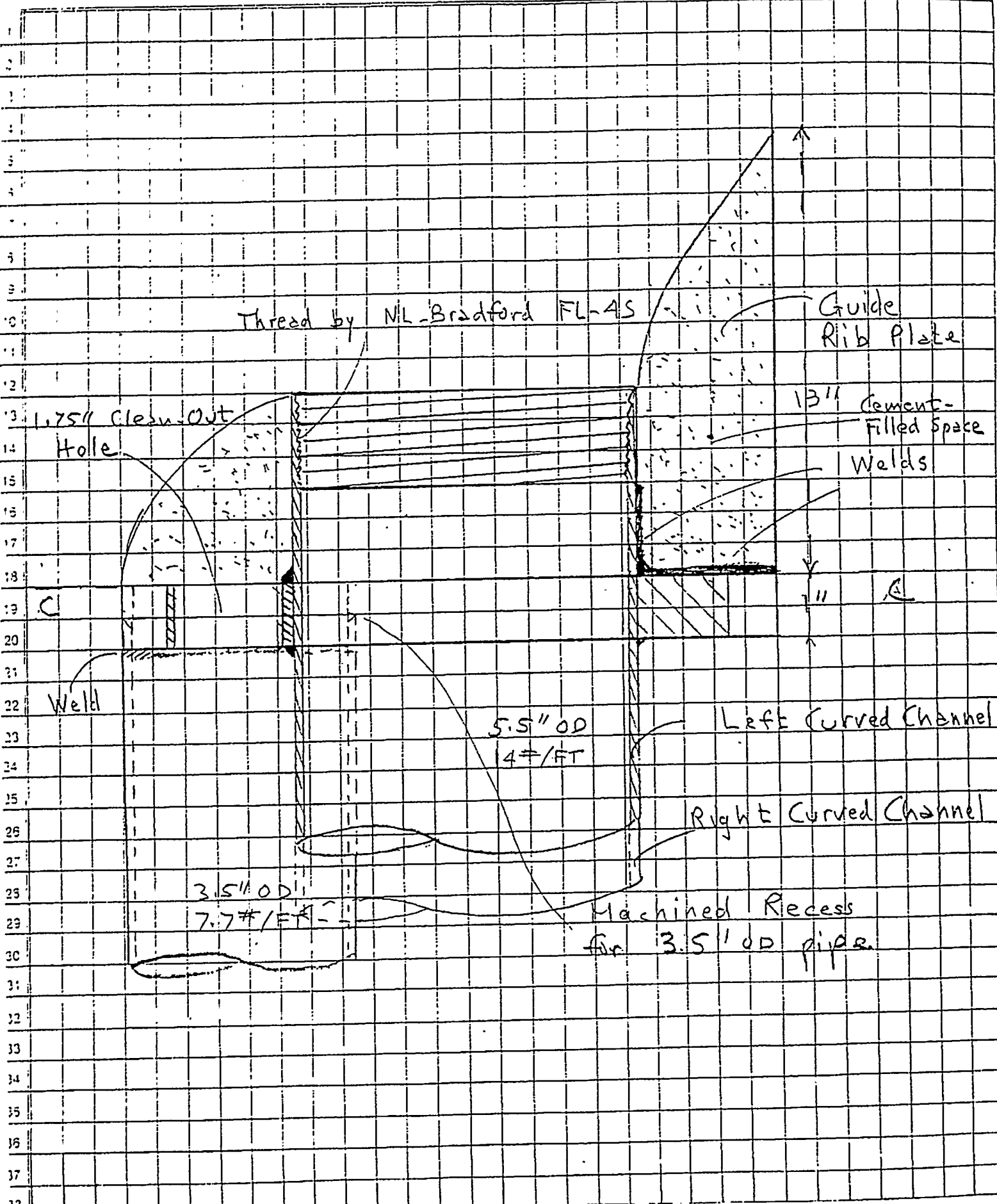

SUBJECT Top Lower Special Casing Joint (TL SJ)
BOTTOM PLATE

FILE DOE/ETAP

DATE 11/10/94

BY MG

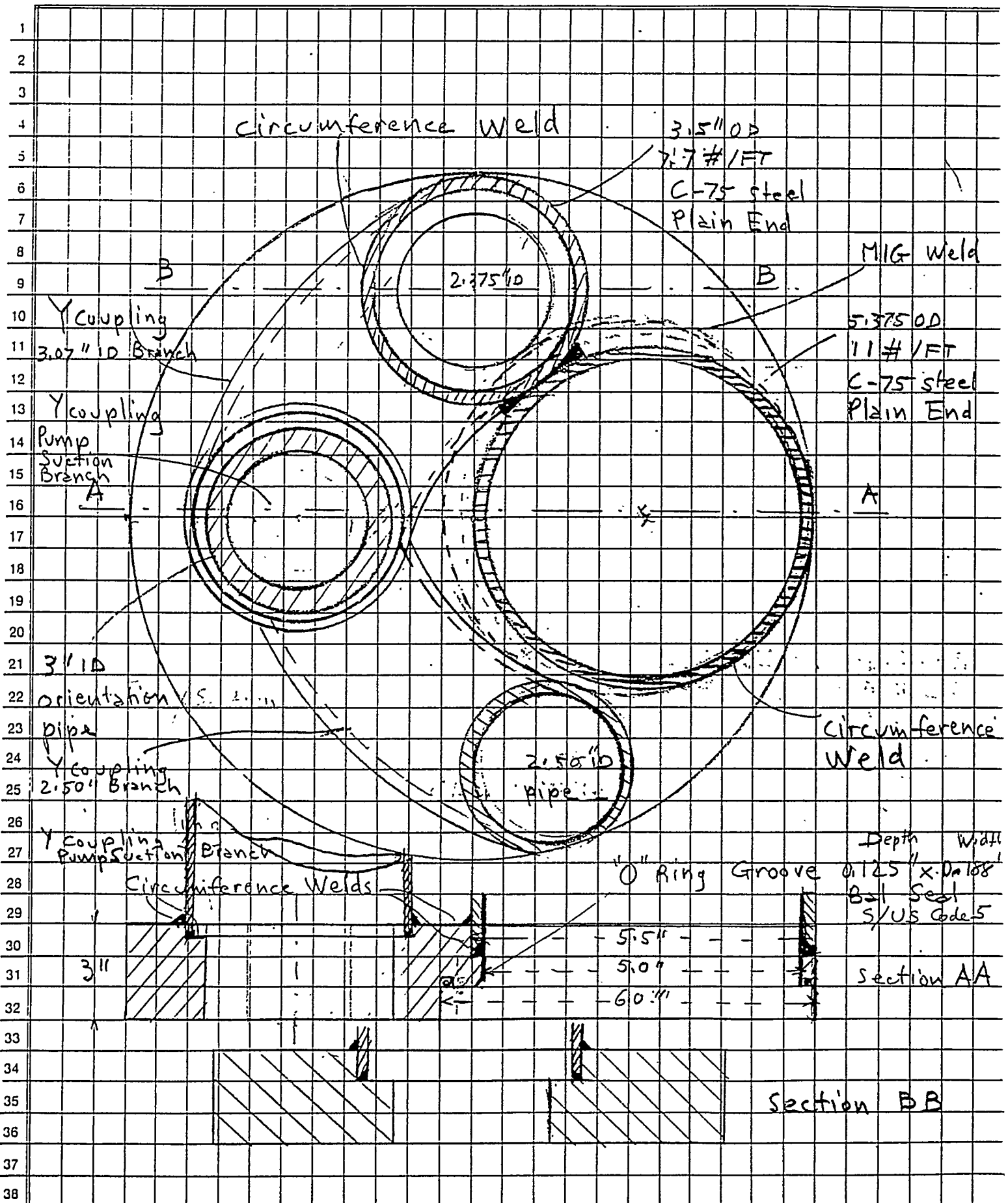

SUBJECT FLOW CONNECTION BETWEEN
BOTTOM OF TLSJ AND TOP OF BLSJ

FILE DOE/ETAP

DATE 11/10/94

BY MG

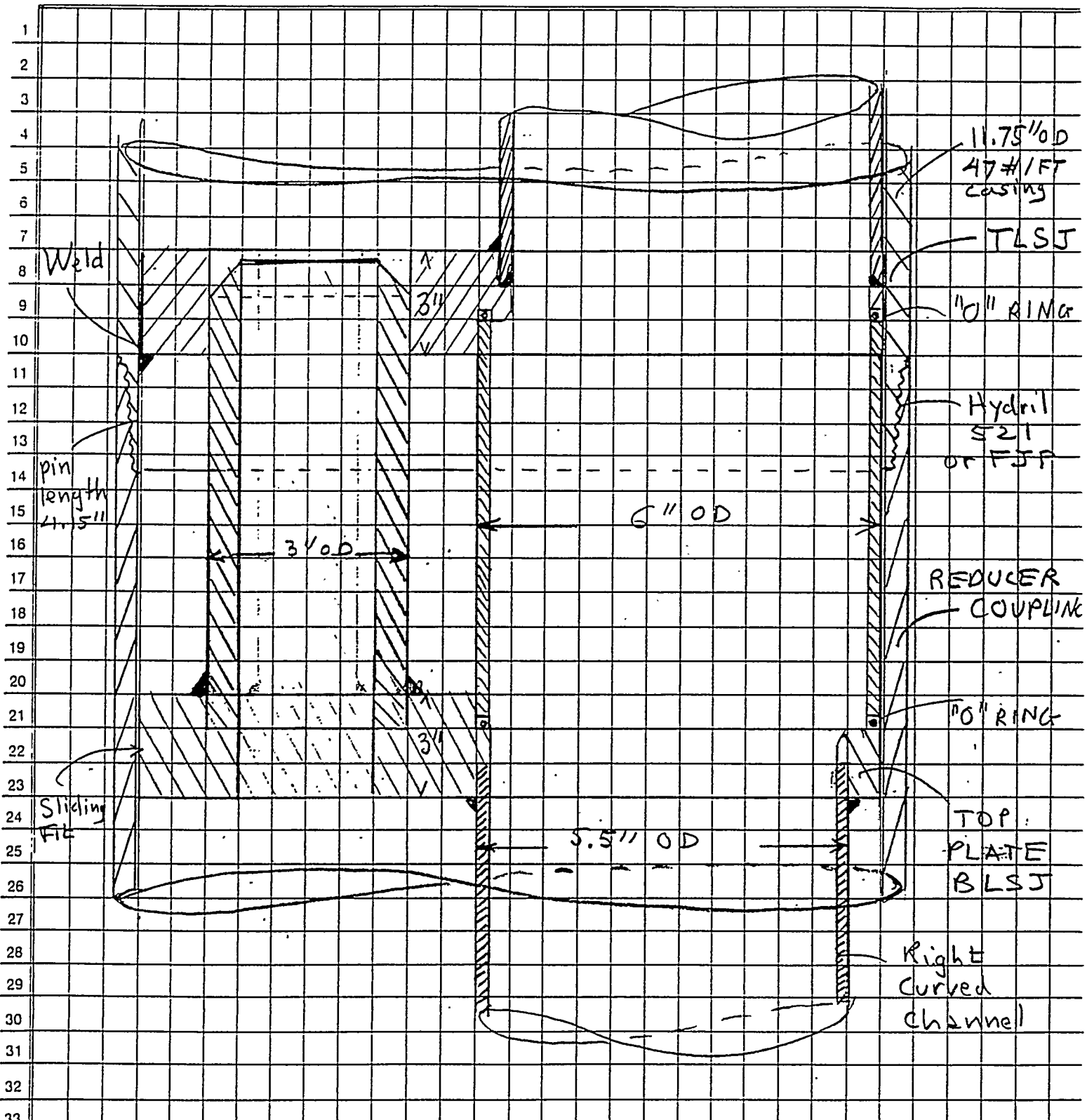

SECTION AA

SUBJECT BOTTOM LOWER SPECIAL JOINT (BLSJ)

FILE D.O.E./ETAP

DATE 11/10/94

BY M.L.G.

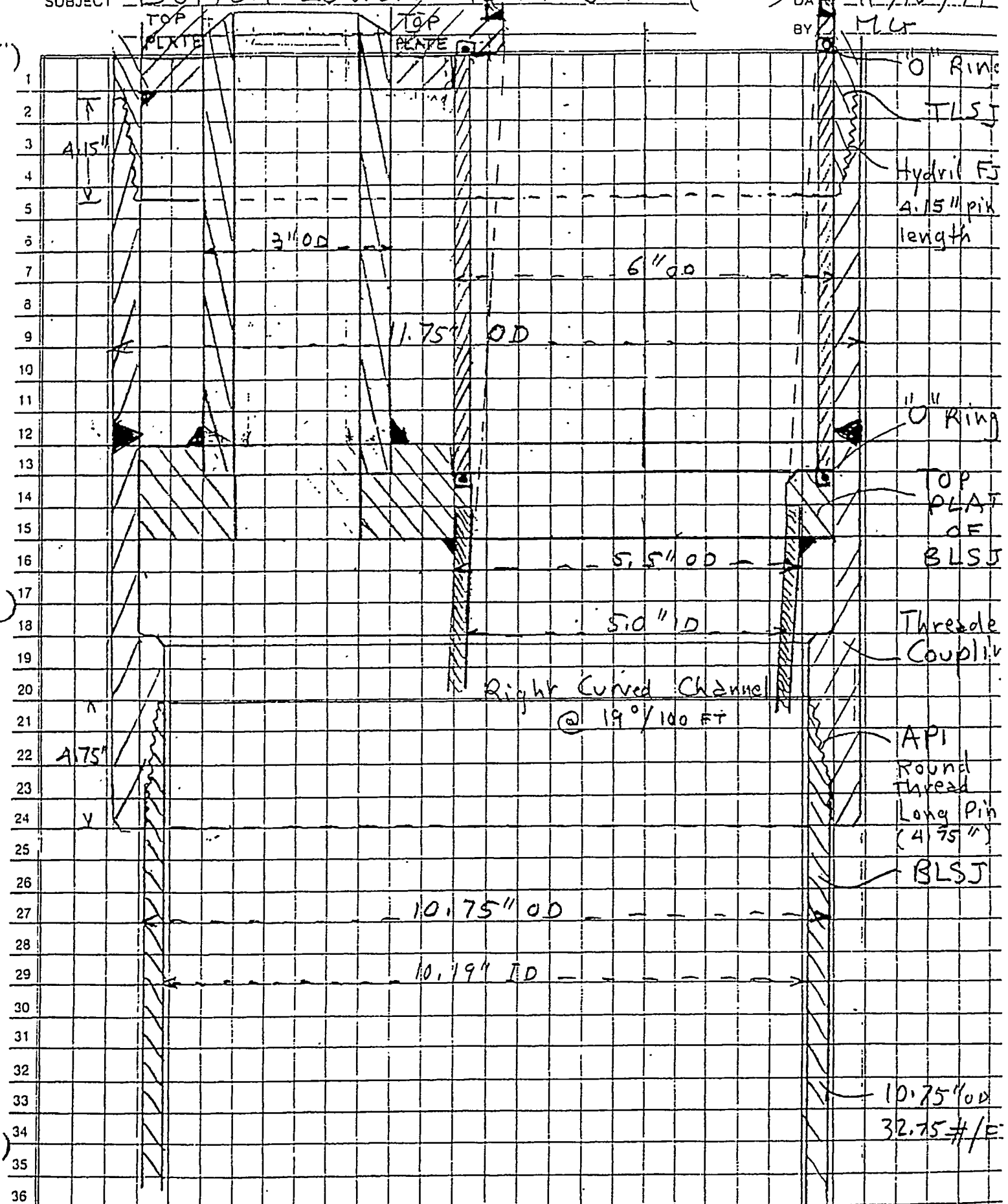

TLSJ and BLSJ Fully Connected

TEST Bottom Plate

Section FF'

Scale 1/1

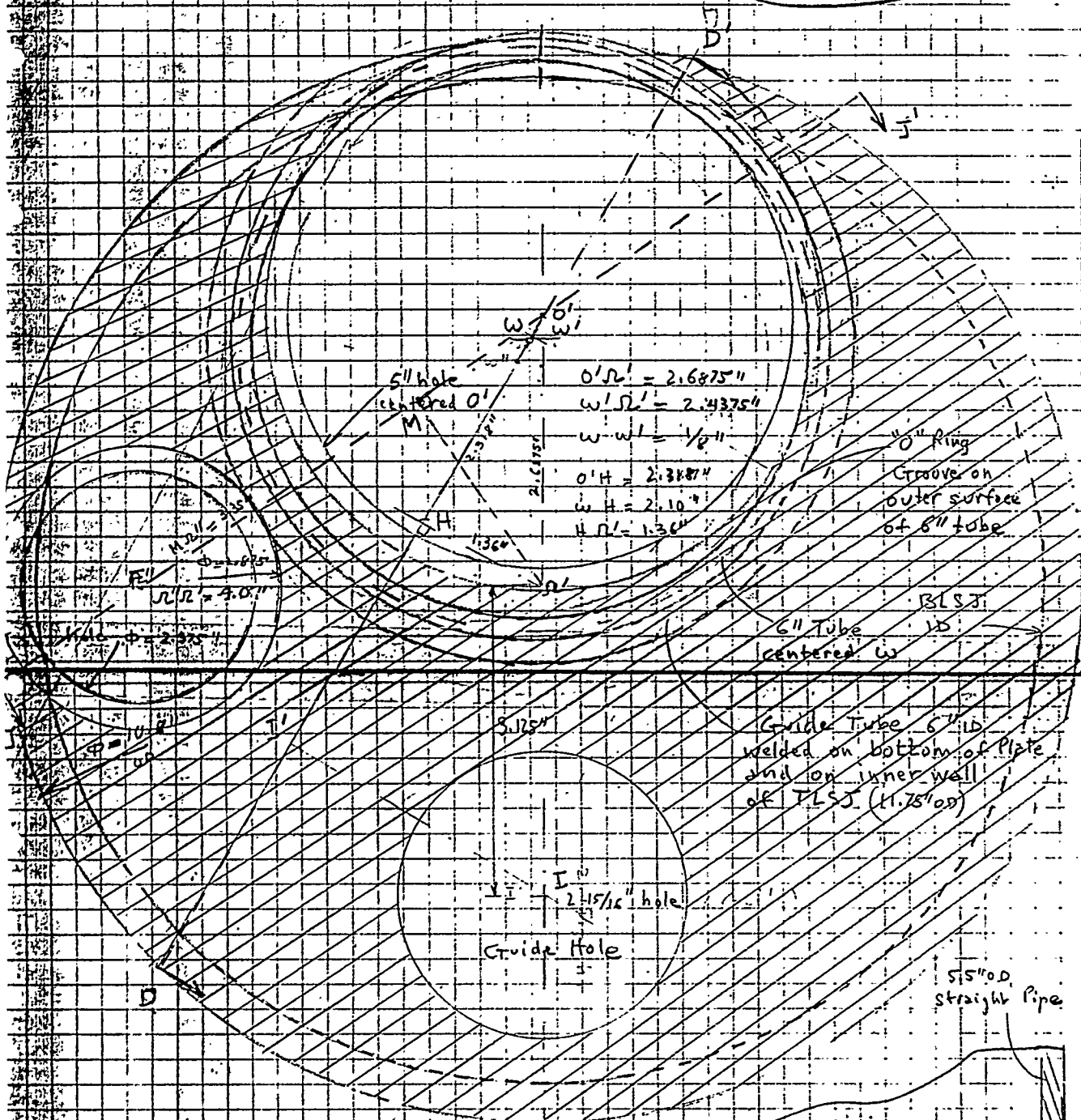

TEST Bottom Plate

Section DD'

5.5" Pipe Groove

Section FF'

Guide Hole

$\times O'$
 $5.5'' OD$
 $5.0'' ID$

$6'' OD$
 $5.5'' ID$

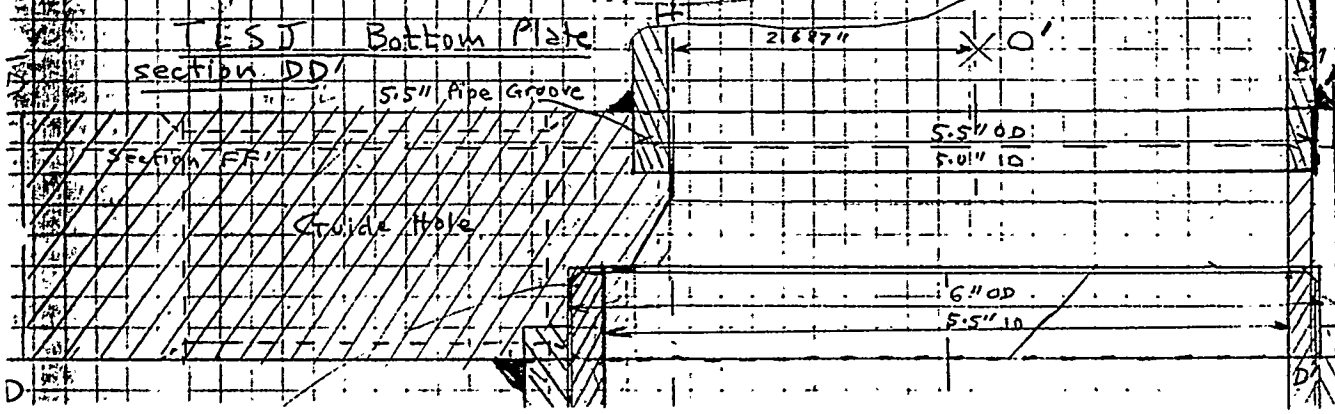

Sheet # 4

TL SJ Bottom Plate

5.5" O.D. pipe

2 7/8" O.D. pipe

Scale: 1/1

Section J J'

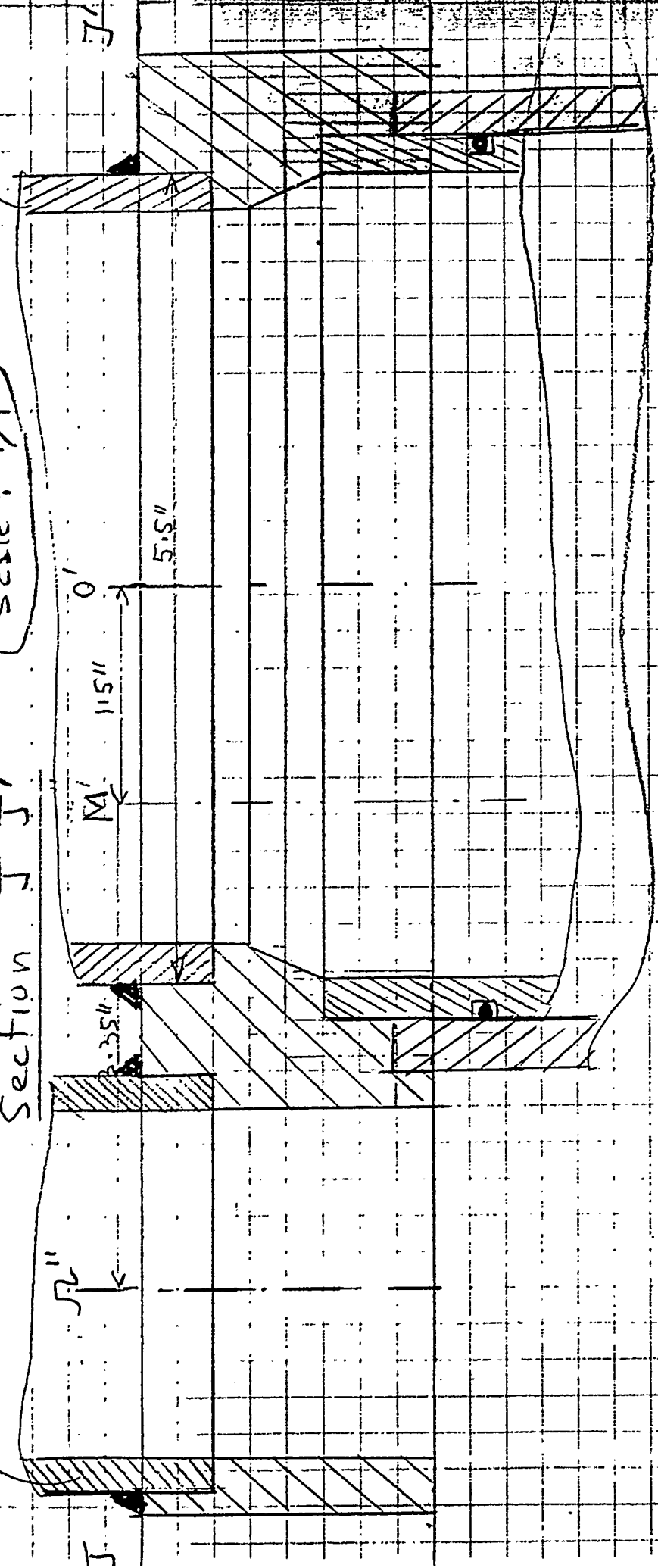

Scale: 1/1

SECTION B-B

Rounded Entrance

Weld Groove Milled out

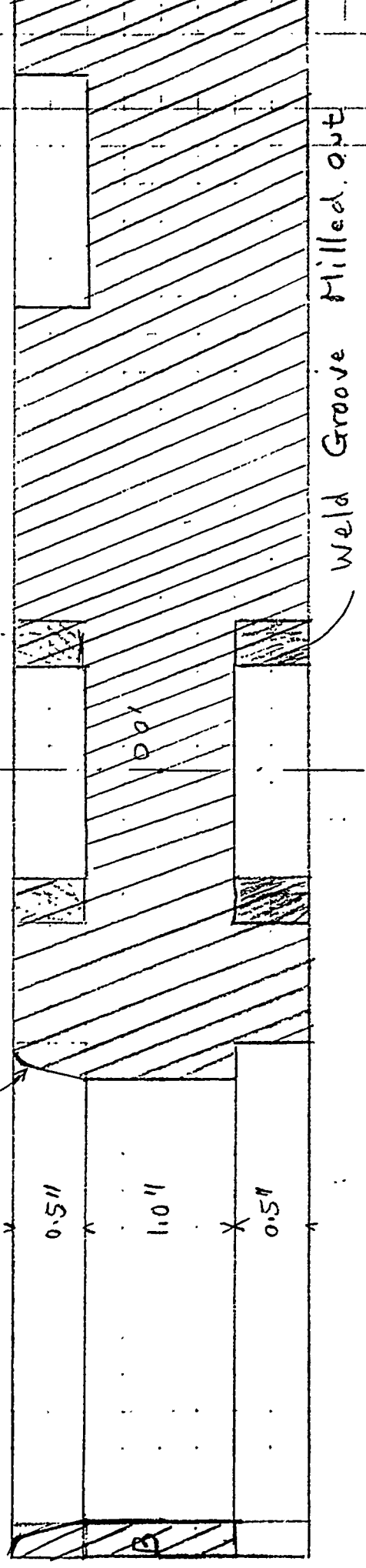

SECTION C-C

Weld Plane

Weld Groove Milled-out

Weld Groove Milled-out

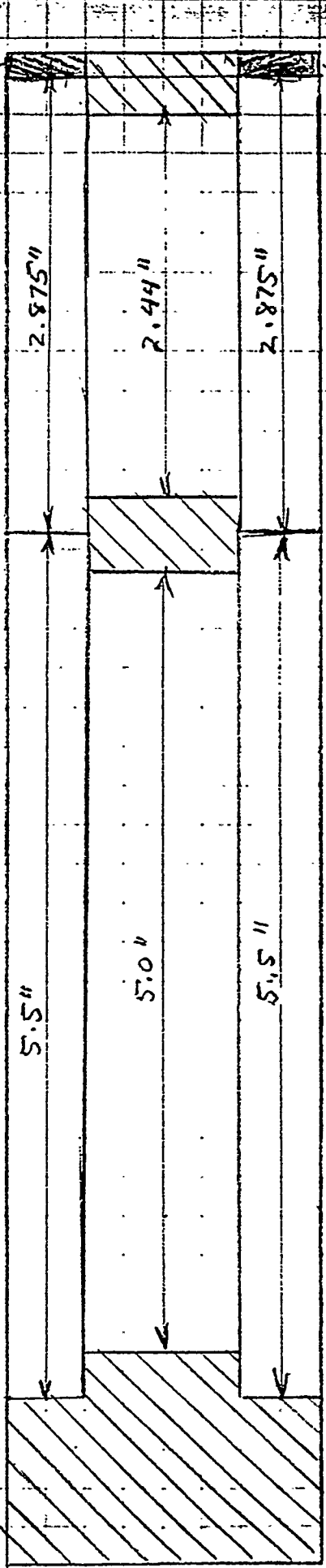

Weld Plane

TOP PLATE OF TLSJ

BSLJ Bottom Plate

TOP VIEW

Scale 1/1

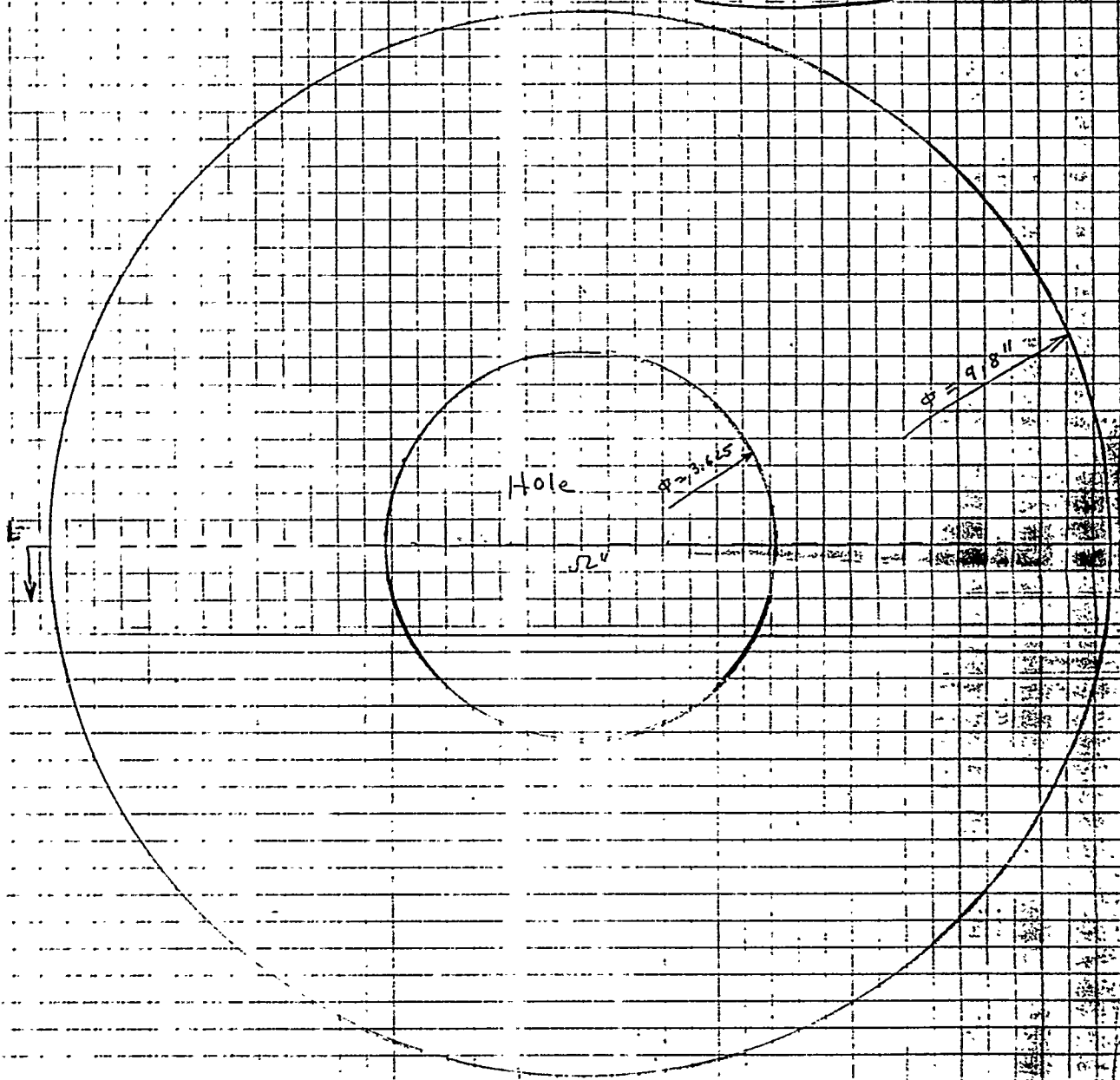

SECTION E-E'

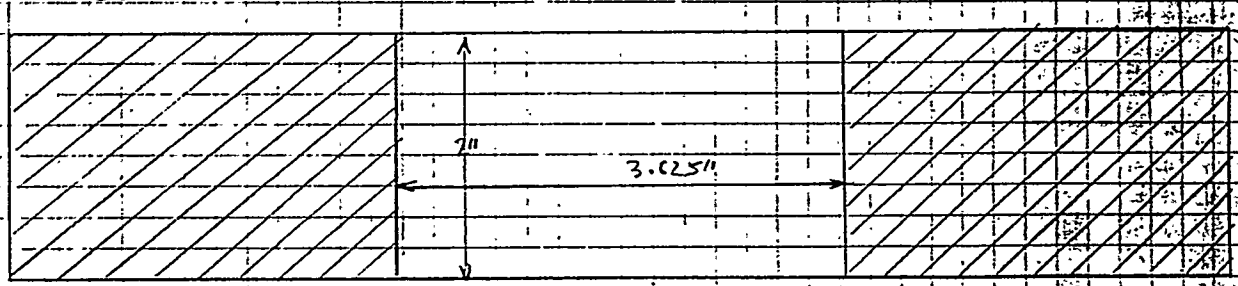

WELLHEAD EQUIPMENT

Tubing Hangers for FTC Tubing Heads

The FTC-1W is a slick-joint wraparound tubing hanger which does not require a polished joint.

The FTC-1A is a threaded hanger with an automatic, load-actuated packoff. This tubing hanger can be supplied with back-pressure valve threads.

The FTCD-2C is a dual completion tubing hanger assembly consisting of a lower master bushing, two hanger couplings with back-pressure valve preparation and sandwich packoff.

The FTC-3C is a triple completion tubing hanger assembly consisting of a master bushing with O-ring seals and three hanger couplings also utilizing O-ring seals and with back-pressure valve preparation. The hanger couplings can be rotated easily to release tubing from packers.

The FTC-1A-EN extended neck tubing hanger is supplied with back-pressure valve, threads and downhole control line preparation, and for service to 15,000 psi.

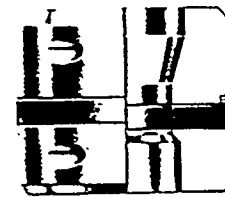

FTC-1W

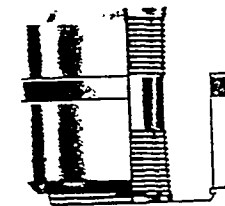

FTC-1A

FTC—Tubing Hangers

Description	Part No. Size 7 1/16 x 2 3/8	Approx. Weight Lbs/Kg	Part No. Size 7 1/16 x 2 3/8	Approx. Weight Lbs/Kg	Part No. Size 7 1/16 x 3 1/2	Approx. Weight Lbs/Kg
Single			10333E2AX1	60.27	03046E2AX1	55.25
FTC-1A	04515E2AX1	68.31	10335E2AX1	64.29	10336E2AX1	60.27
FTC-1A (For B P Valve)	10334E2AX1	72.33	02196E2AX1	65.30	02685E2AX1	60.27
FTC-1W	02263E2AX1	70.32				

FTCD-2C Dual Hangers

Description	Centers	Part No.	Approx. Weight Lbs/Kg
7 1/16 x 2 3/8 EUE x 2 3/8 EUE	3 3/8	02239E2AX1	60.27
9 x 2 3/8 EUE x 2 3/8 EUE	3 3/8	10337E2AX1	92.42
9 x 2 3/8 EUE x 2 7/8 EUE			

FTC-3C Triple Hangers

Description	Radius	Part No.	Wt.
11 x 2 3/8 EUE x 2 3/8 EUE x 2 3/8 EUE			165.75

FTC-1A-EN Tubing Hanger For 3000-5000 W.P.*

Description	Part No.	Approx. Weight Lbs/Kgs
7 1/16 x 2 3/8	14056	108.48
7 1/16 x 2 3/8	14057	101.45
7 1/16 x 3 1/2	13679	74.33

FTC-1A-EN Tubing Hanger W/Down Hole Control Line Preparation for 3000-5000 W.P.*

Description	Part No.	Approx. Weight Lbs/Kgs
7 1/16 x 2 3/8	14058	108.48
7 1/16 x 2 3/8	14059	101.45
7 1/16 x 3 1/2	14060	74.33

*Available upon request for 10 000 and 15 000 W.P

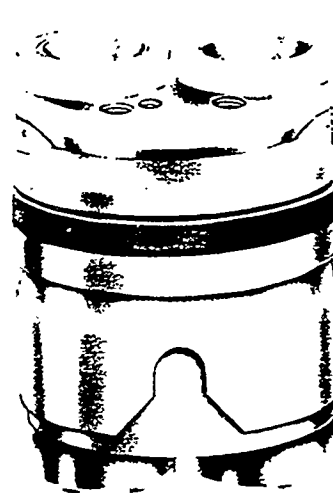

FTCD-2C Dual Hanger

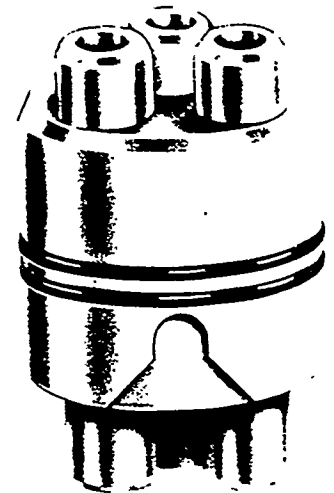

FTC-3C Triple Hanger

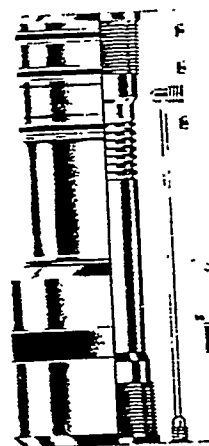

FTC-1A-EN Single Completion Tubing Hanger



FU Tubing Heads

The FIP Universal Tubing Head for single or dual completion, are of tapered bowl design, full opening and provides extra safety with annulus packoff, which provides complete well control. It is ideal in situations where last minute changes in completions are desired. This can be accomplished without changing tubing heads or using special attachments. If only one

producing zone is found in a proposed dual well, the well can be completed by using a single-string hanger. If a second zone is found in a well which was scheduled for single completion, a dual hanger may be used to complete the well. This universal feature means a considerable savings in time and money.

FU Tubing Heads are available in various sizes and pressure ratings

in accordance with API Specifications. They are equipped with two retractable aligning screws which are used to align multiple hangers within the head. Aligning screws are retracted when single string hangers are used.

FUM Tubing Head is a Universal modified for single completion only. It is the same as the Universal but without aligning screws.

FU Tubing Heads

Size	Top Flange		Bottom Flange		Outlets	Inches				Part Numbers		Approx. Weight Lbs/Kg
	WP	Size	WP	Size		A	B	C	D	FU	FU-00	
7" 1/2	3,000	11	2,000	2 Thd	2	19 3/8	9 3/4	9 3/4	7	*0803E2AX1	10840E2AX1	550 250
7" 1/2	3,000	11	2,000	2 1/4" 5,000	5	19 3/8	9 3/4	9 3/4	7	*0822E2AX1	10856E2AX1	555 252
7" 1/2	3,000	11	3,000	2 Thd	2	22 1/4	11 7/8	11 7/8	7	*0806E2AX1	10842E2AX1	600/272
7" 1/2	3,000	11	3,000	2 1/4" 5,000	5	22 1/4	11 7/8	11 7/8	7	*0825E2AX1	*0858E2AX1	600 272
7" 1/2	3,000	13 3/8	2,000	2 Thd	2	19 1/2	9 3/4	9 3/4	7	*0814E2AX1	*0847E2AX1	620 287
7" 1/2	3,000	13 3/8	2,000	2 1/4" 5,000	5	19 1/2	9 3/4	9 3/4	7	10833E2AX1	10861E2AX1	625/284
7" 1/2	3,000	13 3/8	3,000	2 Thd	2	24 1/2	11 7/8	11 7/8	7	*0816E2AX1	*0849E2AX1	675 305
7" 1/2	3,000	13 3/8	3,000	2 1/4" 5,000	5	24 1/2	11 7/8	11 7/8	7	10835E2AX1	10863E2AX1	670 304
7" 1/2	5,000	11	3,000	2 Thd	2	22 1/4	11 7/8	11 7/8	7	10808E2AX1	10843E2AX1	664/302
7" 1/2	5,000	11	3,000	2 1/4" 5,000	5	22 1/4	11 7/8	11 7/8	7	*0827E2AX1	*0337E2AX1	670 304
7" 1/2	5,000	11	5,000	2 Thd	2	24 1/2	12 3/8	12 3/8	7	10810E2AX1	*084E2AX1	821 373
7" 1/2	5,000	11	5,000	2 1/4" 5,000	5	24 1/2	12 3/8	12 3/8	7	10829E2AX1	0337E2AX1	825/375
7" 1/2	5,000	13 3/8	3,000	2 Thd	2	24 1/2	11 7/8	11 7/8	7	*0818E2AX1	10851E2AX1	905 411
7" 1/2	5,000	13 3/8	3,000	2 1/4" 5,000	5	24 1/2	11 7/8	11 7/8	7	*0837E2AX1	*0865E2AX1	910 413
7" 1/2	5,000	13 3/8	5,000	2 Thd	2	21 3/8	9 3/4	9 3/4	7			1094/497
7" 1/2	5,000	13 3/8	5,000	2 1/4" 5,000	5	21 3/8	9 3/4	9 3/4	7			1100 499
7" 1/2	10,000	11	5,000	1 3/4" 10,000	25	25	3 1/2	3 1/2	7	02417E2AX1		1170 532
7" 1/2	10,000	11	10,000	1 3/4" 10,000	25 3/8	12 3/4	9 3/4	9 3/4	7	10869E2AX1		1426/648

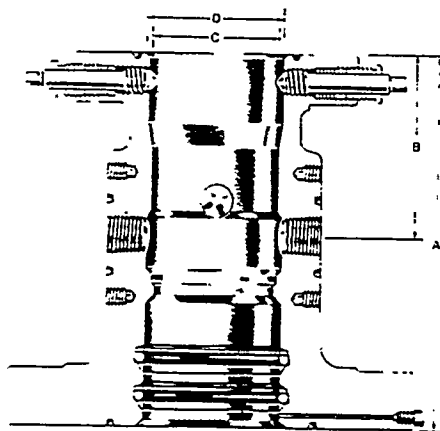

FU-00 Tubing Head

Tubing Hangers for FU Tubing Heads

The FU-30 is a mandrel type tubing hanger which provides the simplest and least expensive method of suspending a single string. This hanger is used when completion methods do not require tubing movement after hanger has been locked into tubing head bowl. It may be run through blowout preventers and it is available with back pressure valve threads.

The FU-41 is a slick-joint wraparound tubing hanger which doesn't require a polished joint, and which holds pressure from both top and bottom.

The FU-60 Tubing Hanger is for dual completions. Its versatility lies in the fact that it consists of two semi-circular halves which may be run or pulled separately. These features allow passage of external gas lift valves with the second string. Each hanger half has threads to accommodate back pressure valves for well control. Casing-tubing annulus seal is effected with the use of semi-circular resilient seals on each hanger half activated by tubing weight and lockdown screws.

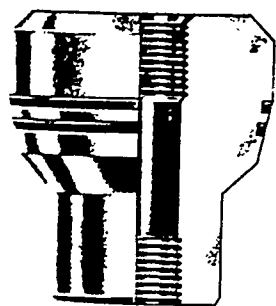

FU-30

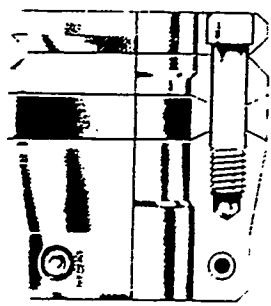

FU-41

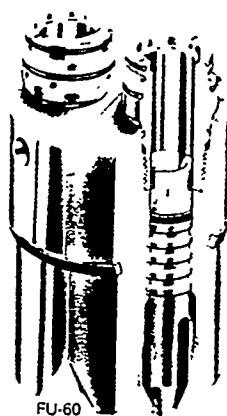

FU-60

FU-30 Tubing Hangers

Size	Part No.	Approx. Weight Lbs/Kg
7" 1/2 x 2 3/8 OD EUE	10325E2AX1	66.30
7" 1/2 x 2" OD EUE	10326E2AX1	48/22
7" 1/2 x 3 1/2 OD EUE	10327E2AX1	46.21

FU-41 Tubing Hangers

Size	Part No.	Approx. Weight Lbs/Kg
7" 1/2 x 2 3/8 OD	49889E2AX1	55.25
7" 1/2 x 2" OD	49880E2AX1	52.24
7" 1/2 x 3 1/2 OD	39007E2AX1	52.24

FU-60 Tubing Hangers

Tubing Head Flange	Hanger	Part No.	Approx. Weight Lbs/Kg
7" 1/2-2,000.			
7" 1/2-3,000.			
7" 1/2-5,000	7" 1/2 x 2 3/8 x 2 3/8	49900E2AX1	81
9-2,000-3,000-5,000	9 x 2 1/8 x 2 7/8	10331E2AX1	194

Multiple Completion Components



Segmented Flange Tees

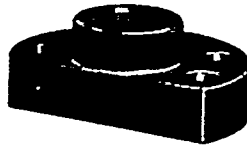

Type A-2 Segmented Adapter Flange



Type DT-609 Dual Tee



Tri-Segmented Adapter

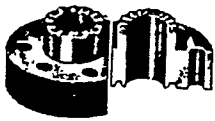

Dual Adapter

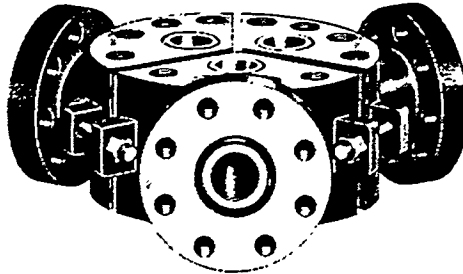

Tri-Segmented Tees

A-2 segmented adapter

Size	Thread	Part No.	Weight
1 ³ / ₄	2" 10 Rd. Non Upset	26-140-165	11 lbs. 5.0 kg.
2	2 ³ / ₈ EUE 8RF	26-140-170	19 lbs. 8.6 kg.
2 ¹ / ₂	2 ⁷ / ₈ EUE 8RF	26-140-171	26 lbs. 11.8 kg.

Tri-segmented adapter

Description	FLANGE			
	Size	W.P.	Radius	Weight
2 x 2 x 2	8 in.	2000	2 ¹ / ₈ in.	188 lbs.
	203.2 mm	138 bar	54.0 mm	85.3 kg.
1 ³ / ₄ x 1 ³ / ₄ x 1 ³ / ₄	6 in.	3000	1 ⁷ / ₈ in.	200 lbs.
	152.4 mm	207 bar	47.6 mm	90.7 kg.
2 x 2 x 2	8 in.	3000	2 ¹ / ₈ in.	265 lbs.
	203.2 mm	207 bar	54.0 mm	120.2 kg.
1 ³ / ₄ x 1 ³ / ₄ x 1 ³ / ₄	6 in.	5000	1 ⁷ / ₈ in.	200 lbs.
	152.4 mm	345 bar	47.6 mm	90.7 kg.
2 x 2 x 2			1 ¹³ / ₁₆ in.	49.2 mm

Tri-segmented tees "TT-613"

Size	Threaded Top	Outlet
1 ³ / ₄	2 ³ / ₈ OD EUE 8RF	2 ¹ / ₁₆ -5,000
1 ³ / ₄	2" Non 10 Rd.	2 ¹ / ₁₆ -5,000
2	2 ³ / ₈ OD EUE 8RF	2 L.P.
2	2 ⁷ / ₈ OD EUE 8RF	2 ¹ / ₁₆ -2,000
2	2 ³ / ₈ OD EUE 8RF	2 ¹ / ₁₆ -5,000
2 ¹ / ₂	2 ⁷ / ₈ OD EUE 8RF	2 L.P.
2 ¹ / ₂	2 ⁷ / ₈ OD EUE 8RF	2 ¹ / ₁₆ -5,000

Available with threaded top.

Segmented flange tees DT-613

Description	OUTLET		Part No.	Approx Weight Each Segment
	Size	W.P.		
1 ³ / ₄ -1 ³ / ₄	2 in. 50.8 mm	L.P.O.	25-514-009	50 lbs 22.7 kg
1 ³ / ₄ -1 ³ / ₄	2 in. 50.8 mm	2000 138 bar	25-514-008	83 lbs 37.7 kg
1 ³ / ₄ -1 ³ / ₄	2 in. 50.8 mm	5000 345 bar	25-514-010	85 lbs 38.6 kg
2	2 in. 50.8 mm	L.P.O.	25-514-013	62 lbs 28.1 kg
2	2 in. 50.8 mm	5000 345 bar	25-514-014	94 lbs 42.6 kg
2 ¹ / ₂	2 in. 50.8 mm	L.P.O.	25-514-025	92 lbs 41.7 kg
2 ¹ / ₂	2 in. 50.8 mm	2000 138 bar	25-514-019	120 lbs 54.4 kg
2 ¹ / ₂	2 in. 50.8 mm	5000 345 bar	25-514-020	124 lbs 56.2 kg

Available with threaded top.

DT-609 dual tee

Description	FLANGE		OUTLET		Part No.	Approx Weight
	Size	W.P.	Size	W.P.		
1 ¹ / ₂ -1 ³ / ₄	6 in. 152.4 mm	3000 207 bar	2 in. 50.8 mm	5000 345 bar	25-512-410	370 lbs 168 kg
2"	6 in. 152.4 mm	3000 207 bar	2 in. 50.8 mm	5000 345 bar	25-512-444	360 lbs 163 kg
1 ¹ / ₂ -1 ³ / ₄	6 in. 152.4 mm	5000 345 bar	2 in. 50.8 mm	5000 345 bar	25-512-620	375 lbs 170 kg
2"	6 in. 152.4 mm	5000 345 bar	2 in. 50.8 mm	5000 345 bar	25-512-645	450 lbs 204 kg
2"	8 in. 203.2 mm	5000 345 bar	2 in. 50.8 mm	5000 345 bar	25-512-660	790 lbs 358 kg
2 ¹ / ₂ "	10 in. 254.0 mm	5000 345 bar	2 in. 50.8 mm	5000 345 bar	25-512-680	1200 lbs 544 kg
1 ¹ / ₂ x 1 ³ / ₄	7 ¹ / ₁₆ in. 179.4 mm	10000 690 bar	2 ¹ / ₁₆ in. 52.4 mm	10000 690 bar		
2"	7 ¹ / ₁₆ in. 179.4 mm	10000 690 bar	2 ¹ / ₁₆ in. 52.4 mm	10000 690 bar		
1 ¹ / ₂ x 1 ³ / ₄	7 ¹ / ₁₆ in. 179.4 mm	15000 1035 bar	2 ¹ / ₁₆ in. 52.4 mm	15000 1035 bar		
2"	7 ¹ / ₁₆ in. 179.4 mm	15000 1035 bar	2 ¹ / ₁₆ in. 52.4 mm	15000 1035 bar		

Dual adapter

Description	FLANGE			Part No.	Weight
	Size	W.P.	Centers		
1 ³ / ₄ x 1 ³ / ₄	6 in. 152.4 mm	2000 38 bar	2 ²⁵ / ₃₂ in. 70.6 mm	02-410-022	130 lbs 81.6 kg.
1 ³ / ₄ x 1 ³ / ₄	6 in. 152.4 mm	3000 207 bar	2 ²⁵ / ₃₂ in. 70.6 mm	02-410-024	139 lbs 89.8 kg.
1 ³ / ₄ x 1 ³ / ₄	6 in. 152.4 mm	5000 345 bar	2 ¹⁵ / ₃₂ in. 62.7 mm	02-410-026	210 lbs 95.3 kg.
2 x 2	6 in. 152.4 mm	3000 207 bar	3 ¹⁵ / ₃₂ in. 88.1 mm	02-410-028	200 lbs 90.7 kg.
2 x 2	6 in. 152.4 mm	5000 345 bar	3 ²⁵ / ₆₄ in. 90.1 mm	02-110-030	200 lbs 90.7 kg.
2 x 2	8 in. 203.2 mm	5000 345 bar	3 ²⁵ / ₆₄ in. 90.1 mm	02-410-036	200 lbs 90.7 kg.
2 x 2	10 in. 254.0 mm	5000 345 bar	3 ²⁵ / ₆₄ in. 90.1 mm	02-410-037	200 lbs 90.7 kg.
2 ¹ / ₂ x 2 ¹ / ₂	10 in. 254.0 mm	3000 207 bar	4 ¹ / ₂ in. 114.3 mm	02-410-042	420 lbs 190.5 kg.
2 ¹ / ₂ x 2 ¹ / ₂	8 in. 203.2 mm	5000 345 bar	4 ¹ / ₂ in. 114.3 mm	02-410-043	200 lbs 90.7 kg.
2 ¹ / ₂ x 2 ¹ / ₂	10 in. 254.0 mm	5000 345 bar	4 ¹ / ₂ in. 114.3 mm	02-410-044	250 lbs 208.7 kg.

Tubingless Completions

Hangers and master bushings

Hangers are available in both threaded and slip types. Either type of hanger may be used interchangeably in all types of master bushings. Threaded hangers can be furnished with grooves for O•C•T™ back-pressure valves. Bushings are available for single, dual, triple, or quadruple completions. Hangers are available to be used with CM and C-18 casing heads.

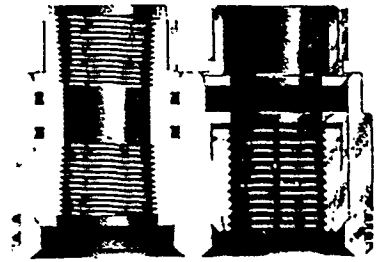

Dual-Threaded and Slip Hangers and Bushing for C-22 Casing Head

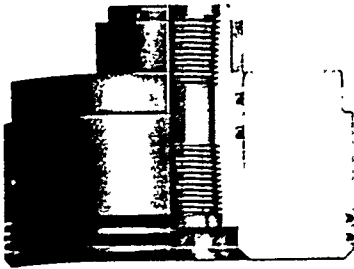

Single-Threaded Tubing Hanger and Bushing for C-22 Casing Head

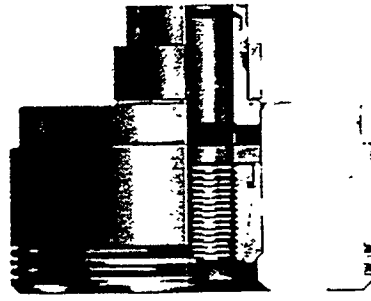

Single Slip-Type Hanger and Bushing for C-22 Casing Head



Threaded Hanger with Grooves for O•C•T Back-Pressure Valve

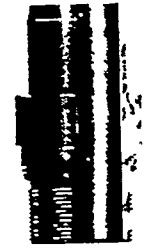

Seal Nipple for Threaded Hangers

Flange adapters

FMC makes both conventional flanged tubing-head adapters and the free-flange adapter. Illustrated is the free-flange adapter.

The free-flange tubing-head adapter simplifies tree assemblies by eliminating the need for aligning pins or orientation flanges. Top connections can be supplied to meet any need, including threaded connections, and sector-shaped connections for crescent flanges, tri-flanges, or quad-flanges.

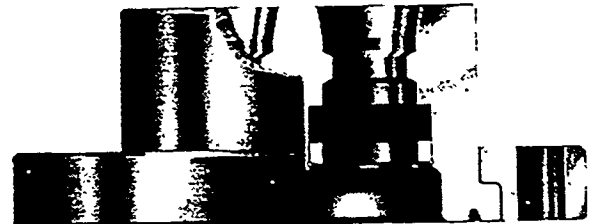

Flanged master valve arrangements

Holddown-flange arrangements

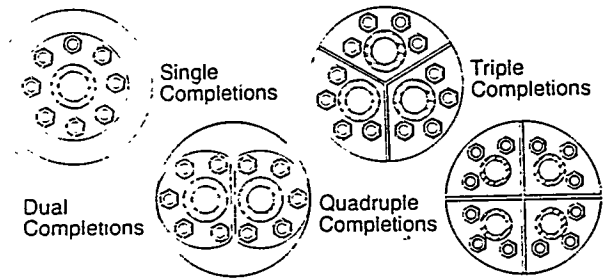
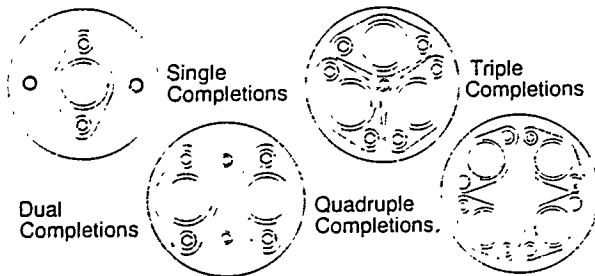

Type-Q tubing heads and hangers

Type Q macaroni tubing heads are supplied for hanging 1 1/2" and smaller inner tubing strings. These O•C•T tubing heads were designed to meet current needs for tubingless completion wellhead equipment. Type Q tubing heads can be supplied with either flanged or threaded connections on top and bottom. Crescent flanges, tri-flanges, and quad-flanges are available. These hangers are also available in models to hang tubing in tension.

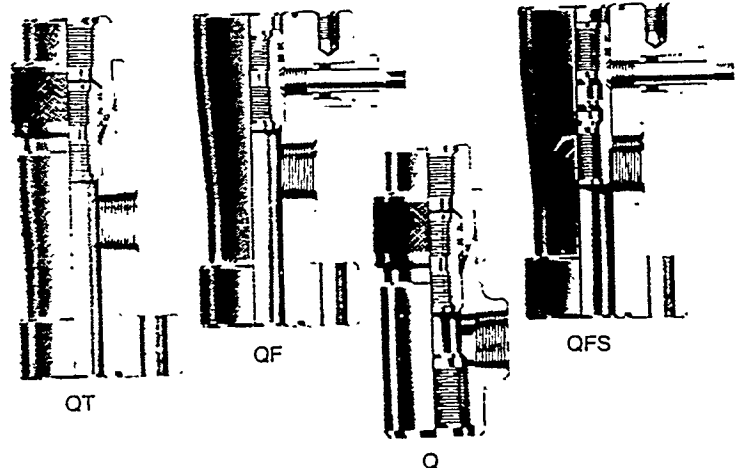

Type TC Tubing Hangers

The TC-2C, TC-3C, and TC-4C tubing hangers are multiple completion hangers consisting of a master bushing with O-ring seals and mandrel-type landing hangers with individual O-ring seals. Each hanger coupling has grooves for the O.C.T.—"IS" back pressure valves. The round mandrel hanger can be rotated easily to release tubing from downhole packers.

The TC-2P dual or TC-3P triple segmented hanger is used when gas lift valves or down hole ball valves are to be run through the TC dual or triple hanger bushings.

The TCM sandwich packoff is a low-cost wraparound hanger for multiple completions that allows the operator to raise all tubing strings simultaneously at completion.



TCD-2C Dual String Hanger



TC-4C Quadruple String Hanger

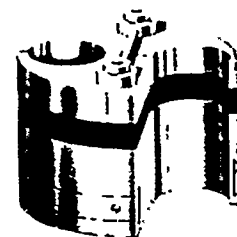

TCM Dual Sandwich Packoff

Dual TC-2C tubing hgrs.

Description	Centers	Part No.	Wt.
5 x 1 1/2 UP x 1 1/2 UP 38.1	2 25/32 in. 70.6 mm	82-780-011	64 lbs. 29.0 kg.
3 x 2 UP x 2 UP 50.8	3 25/64 in. 90.1 mm	82-780-025	95 lbs. 43.1 kg.
10 x 2 UP x 2 UP 50.8	3 25/64 in. 90.1 mm	82-780-075	169 lbs. 76.7 kg.
10 x 2 1/2 UP x 2 1/2 63.5	4 1/2 in. 114.3 mm	82-780-077	163 lbs. 73.9 kg.

Dual TC-2P

Description	Centers	Part No.	Wt.
5 x 2 UP x 2 UP 50.8	3 25/64 in. 90.1 mm	82-650-609	
3 x 2 UP x 2 UP 50.8	3 25/64 in. 90.1 mm	82-650-659	

Triple TC-3C tubing hgrs.

Description	Radius	Part No.	Wt.
5 x 1 1/2 UP x 1 1/2 UP x 1 1/2 UP 38.1	1 7/8 in. 47.6 mm	82-800-010	65 lbs. 29.5 kg.
3 x 2 UP x 2 UP x 2 UP 50.8		82-800-025	96 lbs. 43.5 kg.
10 x 2 UP x 2 UP x 2 UP 50.8		82-800-010	165 lbs. 74.8 kg.

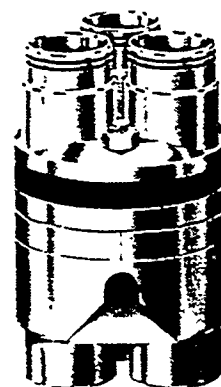

TC-3P Triple Segmented Hanger

TYPE "SLRT" SINGLE AND MULTIPLE TUBING HANGERS

The "SLRT" series of tubing hangers is available for single, dual, triple and quadruple completions. These hangers are aligned by a key and slot mechanism. Tubing strings can be run or pulled in any order desired, and with this series of hangers, the tubing can be rotated or placed in tension even during completion. Annulus and bore pressure control also is maintained at all times during completion.

"SLRT-2" Tubing Hangers have McEvoy — Otis B.P.V. Preparations.

"SLRT-3" Tubing Hangers have threaded B.P.V. Preparations.

TYPE OF COMPLETION	BOWL SIZE	TUBING SIZE	CENTERLINE OR RADIUS	PART NUMBER	
				SLRT	SLRT-2
Single	8"	2 ⁷ / ₈ " Up. Tbg.	—	—	542137
Dual	10"	2 ⁷ / ₈ " Up Tbg. × 2 ⁷ / ₈ " Up. Tbg.	3 ³ / ₄ "	598849	—
	8"	2 ⁷ / ₈ " CS Hyd. × 2 ⁷ / ₈ " CS Hyd.	3 ³ / ₄ "	597087	555858
	8"	2 ³ / ₈ " Up. Tbg. × 2 ³ / ₈ " CS Hyd.	2 ³ / ₈ "	—	558807
	10"	2 ³ / ₈ " Up. Tbg. × 2 ³ / ₈ " Up. Tbg.	3 ³⁵ / ₆₄ "	554218	—
	8"	2 ³ / ₈ " Up. Tbg. × 2 ³ / ₈ " Up. Tbg.	3 ³⁵ / ₆₄ "	—	528583
	10"	2 ⁷ / ₈ " × 2 ⁷ / ₈ " Up. Tbg.	4"	—	528620
Triple	10"	2 ³ / ₈ " × 2 ³ / ₈ " × 2 ³ / ₈ " Up. Tbg.	2 ¹ / ₈ R	548677	528598
Quadruple	10"	2 ³ / ₈ " Up. Tbg.	3 ¹ / ₁₆ R	—	528590



"SLRT" SINGLE

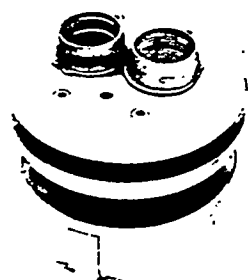

"SLRT" DUAL

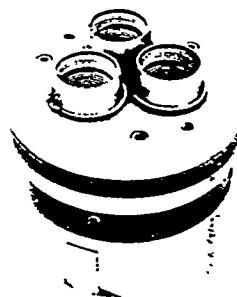

"SLRT" TRIPLE

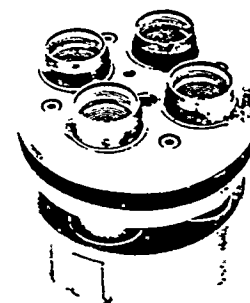

"SLRT" QUADRUPLE

TUBINGLESS COMPLETION HANGERS FOR TUBING SMALLER THAN 4 INCHES

The "SSLRT" equipment provides a method of making a collar and/or slip suspension in the same hanger housing. If a conventional completion has been planned and because of unforeseen difficulties it becomes necessary to make a slip suspension completion after tubing has been run it can be accomplished by replacing the landing coupling with a false bowl and slips. The slip suspension completion also permits the setting of the tubing in tension. Available in single and quadruple completions.

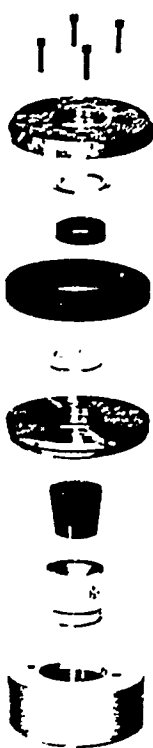

Slip Suspension

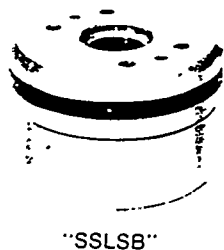

"SSLSB"



Mandrel Suspension

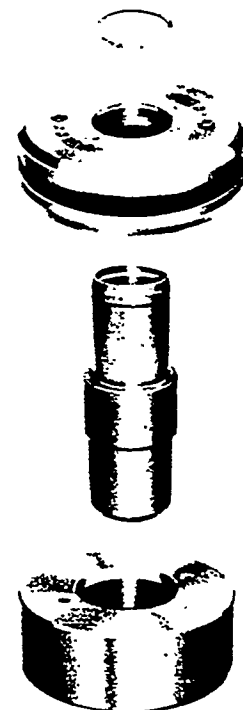

The type "SL" bowl in the McEvoy All Purpose Head has the same profile as the type "S" casing head bowl and incorporates added features which provide the all purpose or versatile aspect of the bowl—one or more tubing strings or casing string can be supported.

The bowl features elongated slots, located 90° from the outlet(s), providing for positive orientation of multiple tubing hangers without removal of the blowout control assembly. This positive orientation can be accomplished through visual inspection by removal of a lockscrew assembly. Heat-treated lock-

screws may be externally adjusted at any time during the life of the well to hold casing or tubing hangers down under light loads, or to adjust the pack-off.

The All Purpose Head will accommodate a series of single and multiple tubing hangers or the Type "SB-1" and "SB-3" casing hangers. This flexible design makes it possible to suspend multiple strings of tubing or a protection casing string should conditions warrant.

This great flexibility in making completions is possible without changing the wellhead or removing the blowout control stack.



Type "SLG-1"

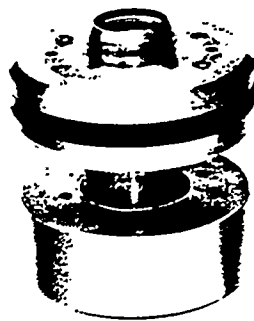

"SSLRT-2" Single



"SSLRT-2" Dual

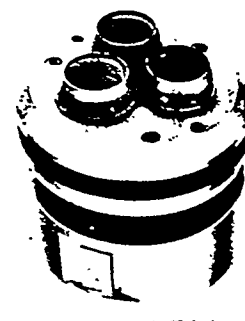

"SSLRT-2" Triple

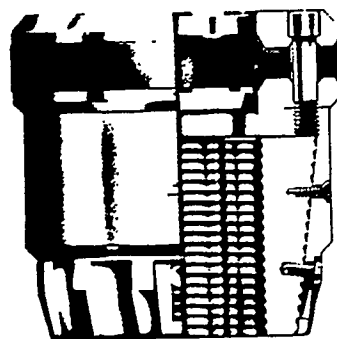

SB-3 Casing Hanger

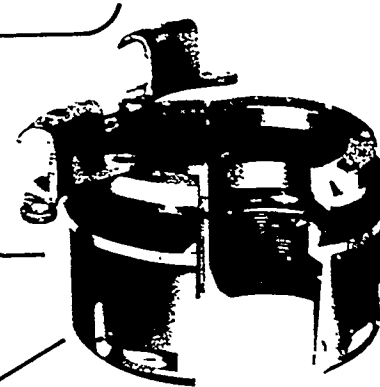
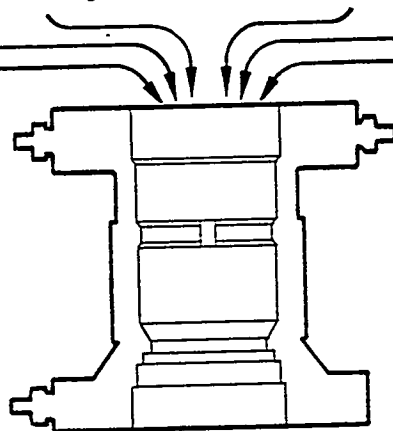

SB-1 Casing Hanger

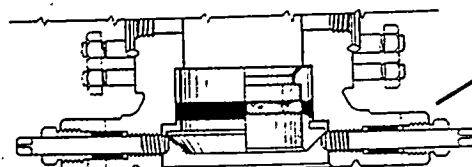

Type "-2" lockscrew secondary seal

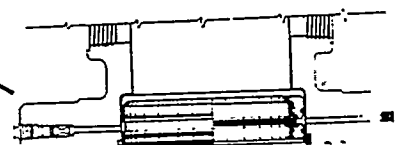

Type "YB" secondary seal

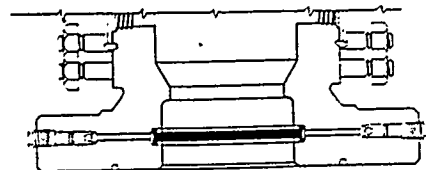

Type "-Y" secondary seal

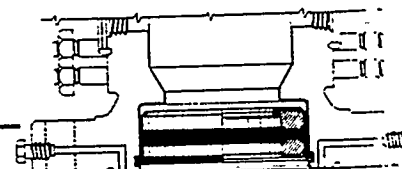

Type "CM" secondary seal

The "SSLRT" equipment provides a method of making a collar and/or slip suspension in the same hanger housing. If a conventional completion has been planned and because of unforeseen difficulties it becomes necessary to make a slip

suspension completion after tubing has been run it can be accomplished by replacing the landing coupling with a slip bowl and slips. The slip suspension completion also permits the setting of the tubing in tension.

- PART NUMBER
- 597885
- 565600
- 598817
- 566032
- 565593
- 558642
- 555752
- 564739
- 565466
- 542901

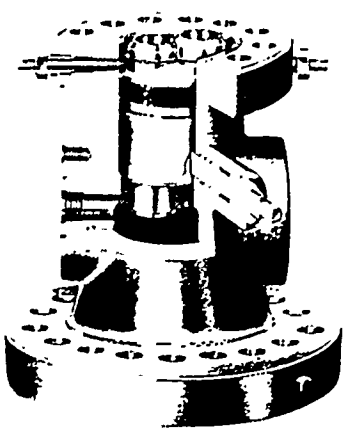

Type "R" equipment reduces well completion costs by use of a 6" upper flange where 8" upper flanges are normally used over 7⁵/₈" casing.

The Type "R" Tubing Head with a 6" nominal top flange provides a 6⁵/₁₆" minimum bore for single or multiple completions over 7⁵/₈" casing. Due to the small tubing hanger support area allowed by providing full size access to 7⁵/₈" casing through a 6" flange, large round retractable lockscrews are used for supplemental support of long tubing strings and flange test pressures.

The Type "R" Tubing Head may be used with 5-bolt, integral, or "stacked" multiples and single completion trees.

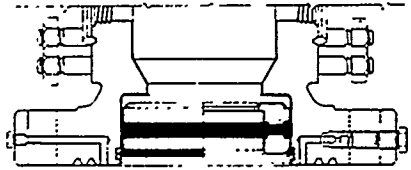

R-C Tubing Head with "CM" Secondary Seal

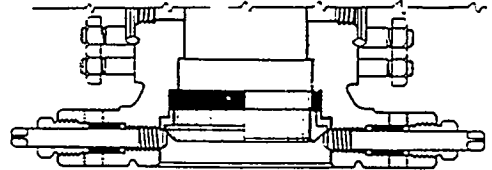

R-1 Tubing Head with "-1" Secondary Seal

BOTTOM FLANGE	TOP FLANGE	BOWL SIZE	STUDED SIDE OUTLETS	MINIMUM BORE	PART NUMBER	BOTTOM FLANGE	TOP FLANGE	BOWL SIZE	STUDED SIDE OUTLETS	MIN. BORE	PART NUMBER
10"-3,000	6"-3,000	7	One 2"-5,000 S.S.O. W/VRT	6 ⁵ / ₁₆ "		10"-3,000	6" - 3,000	7	Two 2" - 5,000 S.S.O. W/VRT	6 ⁵ / ₁₆ "	
10"-3,000	6"-3,000	7	Two 2"-5,000 S.S.O. W/VRT	6 ⁵ / ₁₆ "		10"-3,000	6" - 5,000	7	Two 2" - 5,000 S.S.O. W/VRT	6 ⁵ / ₁₆ "	546540
10"-3,000	6"-5,000	7	One 2"-5,000 S.S.O. W/VRT	6 ⁵ / ₁₆ "	548224	10"-5,000	6" - 5,000	7	Two 2" - 5,000 S.S.O. W/VRT	6 ⁵ / ₁₆ "	547321
10"-3,000	6"-5,000	7	Two 2"-5,000 S.S.O. W/VRT	6 ⁵ / ₁₆ "	548220	10"-5,000	7 ¹ / ₁₆ "-10,000	7	Two 2 ¹ / ₁₆ "-10,000 S.S.O. W/VRT	6 ⁵ / ₁₆ "	546963

TYPE "RG-1" TUBING HANGERS, SINGLE

The RG-1 is designed for speed and ease of operation, eliminating the costly polished joint. The hanger is used when the operator desires to circulate around the tubing after the tree has been completely installed. This wrap-around type of hanger will support the full weight of the tubing by setting the collar down on the hanger. The packing can be tightened by means of lockscrews.

BOWL SIZE	TUBING SIZE	PART NUMBER
7	4 ¹ / ₂ " PH-6 Hyd.	558886
7	2 ⁷ / ₈ " Up. Tbg.	546518
7	2 ⁷ / ₈ " Up. Tbg.	548673
7	2 ³ / ₈ " Up. Tbg.	546520
10	3 ¹ / ₂ " CS Hyd.	564930

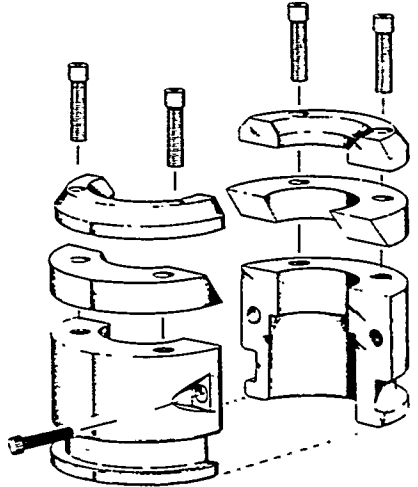
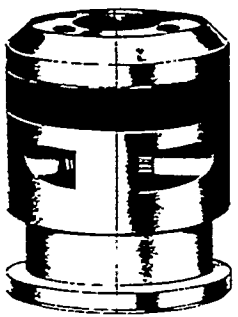

TYPE "RBF" TUBING HANGERS, DUAL

The RBF is recommended for use with gas lift valves or when other projecting devices are run on the tubing strings. With one tubing string suspended, maximum clearance is provided for passage of these projections on the other string while it is being run. The hanger is designed to permit both tubing strings to be run, hung or pulled independently. The pack-off can be run either attached to the second string of tubing or separately.

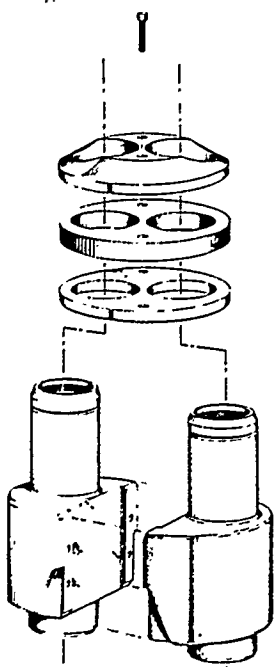

BOWL SIZE	TUBING SIZE (INCHES)	CENTER LINE	PART NUMBER	
			RBF-2	RBF-3
7"	2 ³ / ₈ " Up. Tbg. x 2 ³ / ₈ " Up. Tbg.		552701	—
7"	2 ³ / ₈ " Pitt-8 Acme x 2 ³ / ₈ " Up. Tbg.	5 ³⁵ / ₆₄	—	563555
7"	2 ³ / ₈ " 4.7 # N-80 Atlas Bradford x 2 ³ / ₈ " Up. Tbg.	3 ³⁵ / ₆₄	562892	—
10"	3 ¹ / ₂ " Up. Tbg. x 3 ¹ / ₂ " CS Hyd.	5 ³ / ₆₄	547285	—

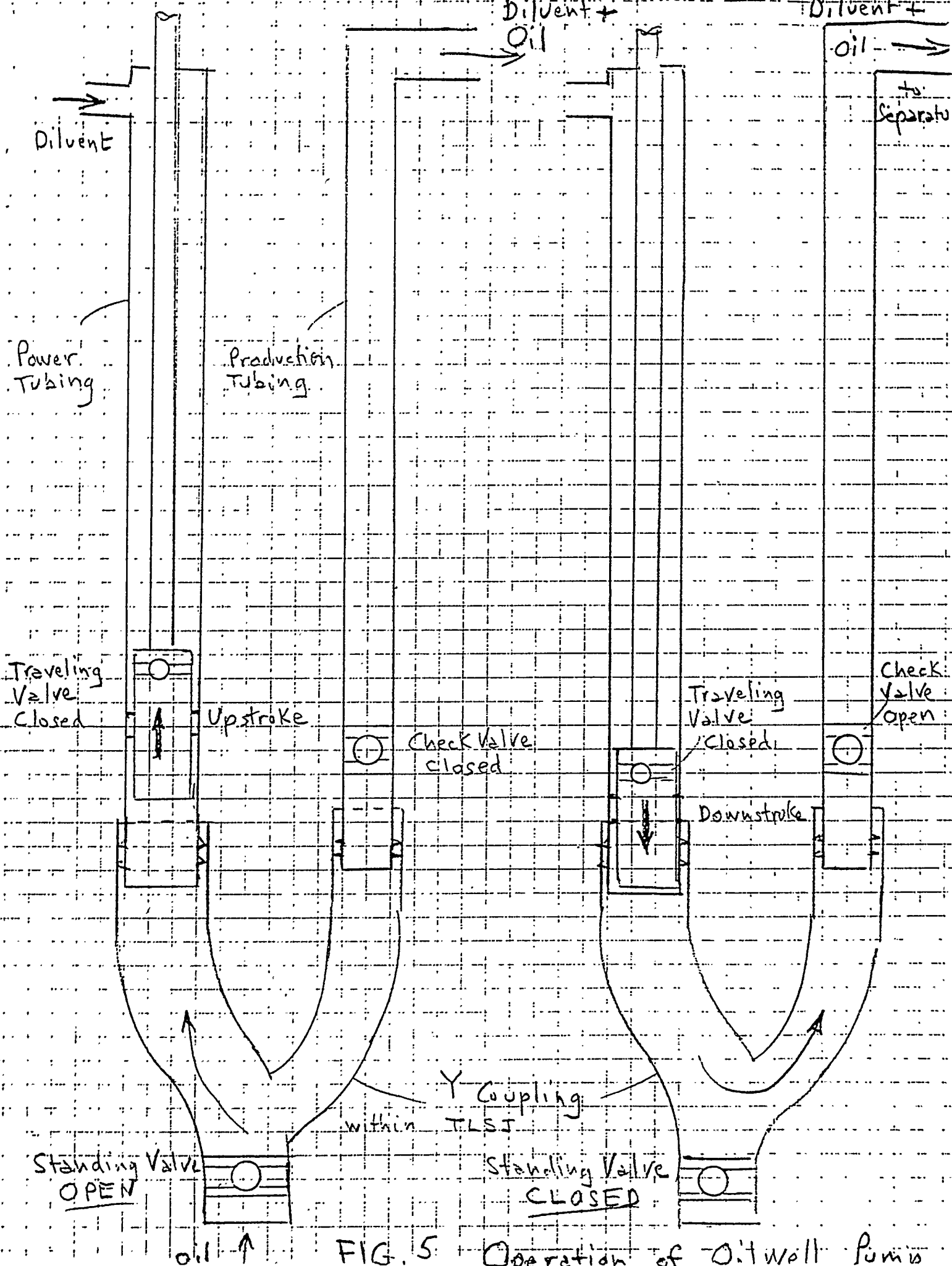

FIG. 5 Operation of Oilwell Pump

VISCOUS FLUID PUMPING SYSTEM

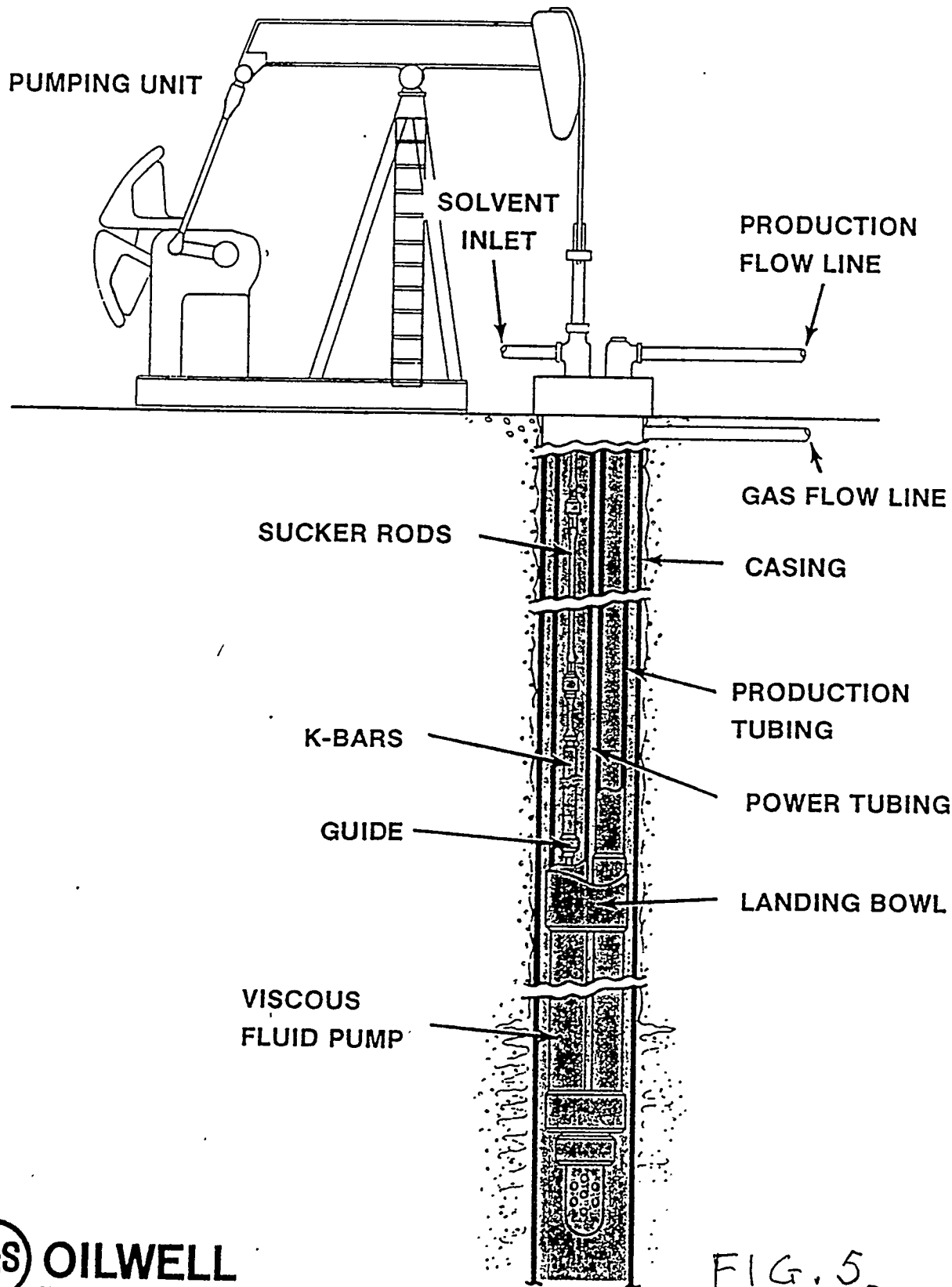
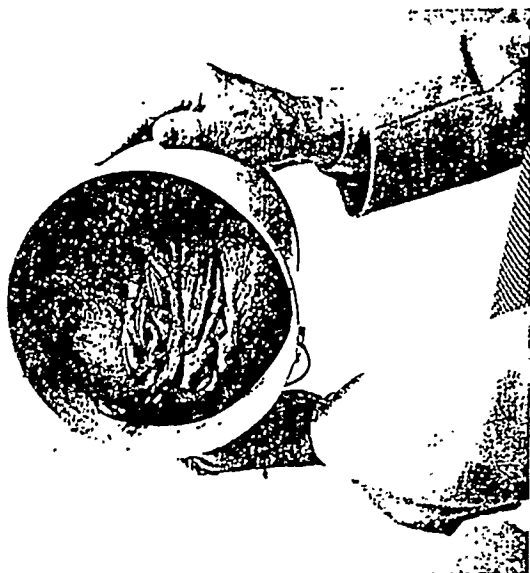

FIG. 5_B

VOP System for Viscous Oil or Sand Laden Fluids

Manufactured Under U.S. Patent No. 4056335



This viscous crude in its native state was taken from a California well now producing API 4.4 gravity oil by a new patented completion system lifting three times the B/D produced by other rod lifting equipment.

The OILWELL Viscous Oil Production System (VOP) is specifically designed for application in wells producing heavy viscous crude and other viscous fluids. The system is especially beneficial in completion where sand or other contaminants are a problem. Design benefits attribute to:

Increased production, as much as three times the production obtained with conventional equipment.

Decreased power consumption.

Decreased maintenance.

Adapts to inhibiting corrosive environments.

Pump wear virtually unaffected by sand or other contaminants.

Simplifies down hole retrieving and replacement of components (pulling wet strings a thing of the past).

Gives wellhead and pump chamber control of distillate fluid flow.

Blends Viscous fluids to acceptable pipeline gravity downhole.

The system consists of a standard beam type pumping unit, a weighted string of sucker rods using OILWELL K-BARS plus two strings of tubing connected to the VOP subsurface pump. Secured at the wellhead, the two strings of tubing run down parallel inside the well casing and suspend the pump at the required production depth.

One tubing string (power string) contains the sucker rods and K-BARS for powering the system. The second tubing string (production string) conducts produced oil to the surface. A unique assembly of spear, landing bowl and crossover connection facilitates installation and removal of system components with conventional well servicing equipment. The VOP pump is specified by the casing size in which it is designed to fit (see Table 1), presently two popular sizes are in production, 7" (178 mm) and 8³/₄" (219 mm). Other sizes above and below these sizes are now in advanced stage of design.

TABLE 1 ENGLISH

Casing Size	Power Tubing	Production Tubing	Pump Bore Diam.	Stroke Length (In.)	Max. Speed (SPM)	Pump Factor (PF)
7"	2 ³ / ₈ "	2 ³ / ₈ "	2" x 1 ³ / ₄ "	Up to & including 168	* See Footnote	.467
8 ³ / ₄ "	2 ³ / ₄ "	2 ³ / ₄ "				

TABLE 1 METRIC

Casing Size mm	Power Tubing mm	Production Tubing mm	Pump Bore Diam. mm	Stroke Length mm	Max. Speed (SPM)	Pump Factor (PF)
178	73	60	51 x 44	Up to & including 4267	* See Footnote	.467
219	73	73				

Gross Fluid Stroke Length x SPM x PF

* Experience indicates maximum speed is governed by flow line pressure and the ability of native crude to enter the well bore. Speeds up to 10SPM are easily obtained.

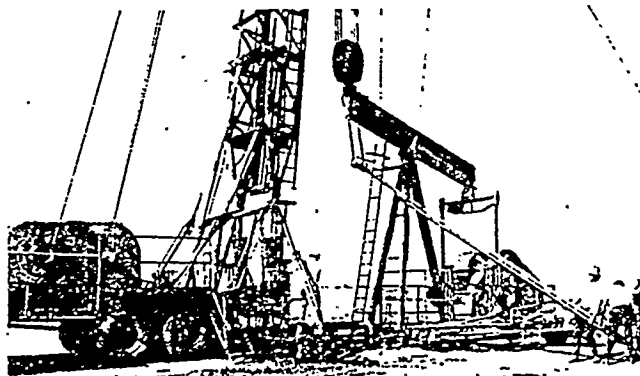

Raising VOP subsurface pump into position for installation into well bore.

CONCEPTUAL DRAWING

FIG. 4 STEAM TUBING COMPLETION ASSEMBLY (Not to Scale)

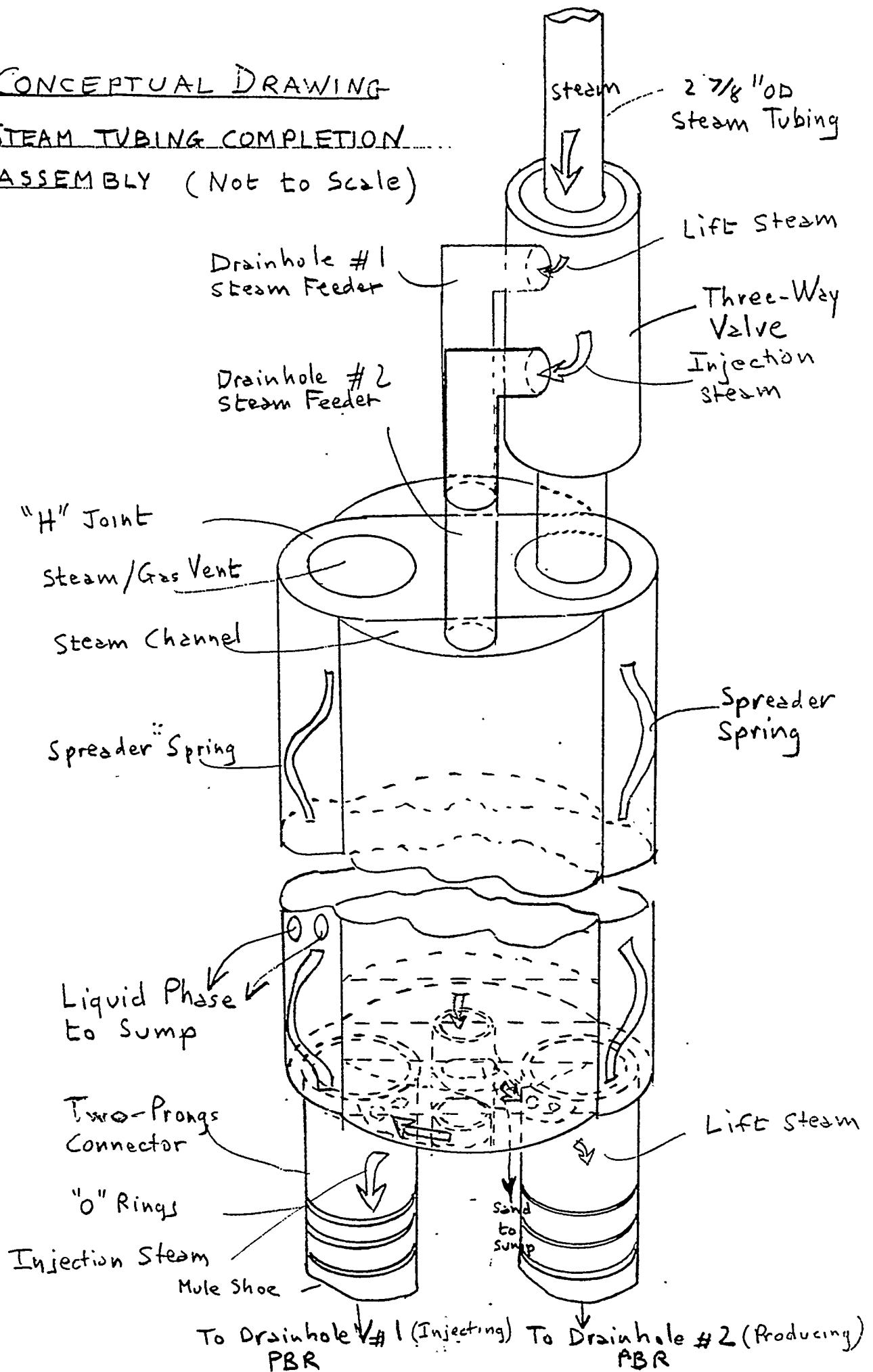

Scale: 0.5" = 1"

Cover Plate of Upper Steam Feeder

Cover Plate of Lower Steam Feeder

Threaded Hole for Orientation of Spacer

Mobile Spacer and 3-Way Valve cylinder Assembly

Mobile Spacer w/ orientation Groove for K.O. Tool (MERLA for 5" TRD)

Welds of Pipes to Back Plate

OTIS X Lock Mandrel (2.62" ID)

4.5" OD OTIS X Landing Nipple (Hanger for 2 7/8" Tbg of Upper Drainhole)

Pipe: 4.5" OD 4.0" ID

OTIS X Lock Mandrel (2.62" ID)

4.5" OD OTIS X Landing Nipple (Hanger for 2 7/8" Tbg of Lower Drainhole)

4 1/4" OD Sealed Prongs (3.875" ID)

Lower Tbg = 2 7/8" OD 2.441" ID

Steam Outlet (To 4" OD Liner / 2 7/8" OD Tbg. Annulus)

Bottom Plate

Upper Tbg = 2 7/8" OD

Window of "H" Joint 7.5" min. height

8.75" min.

4" min.

30" max.

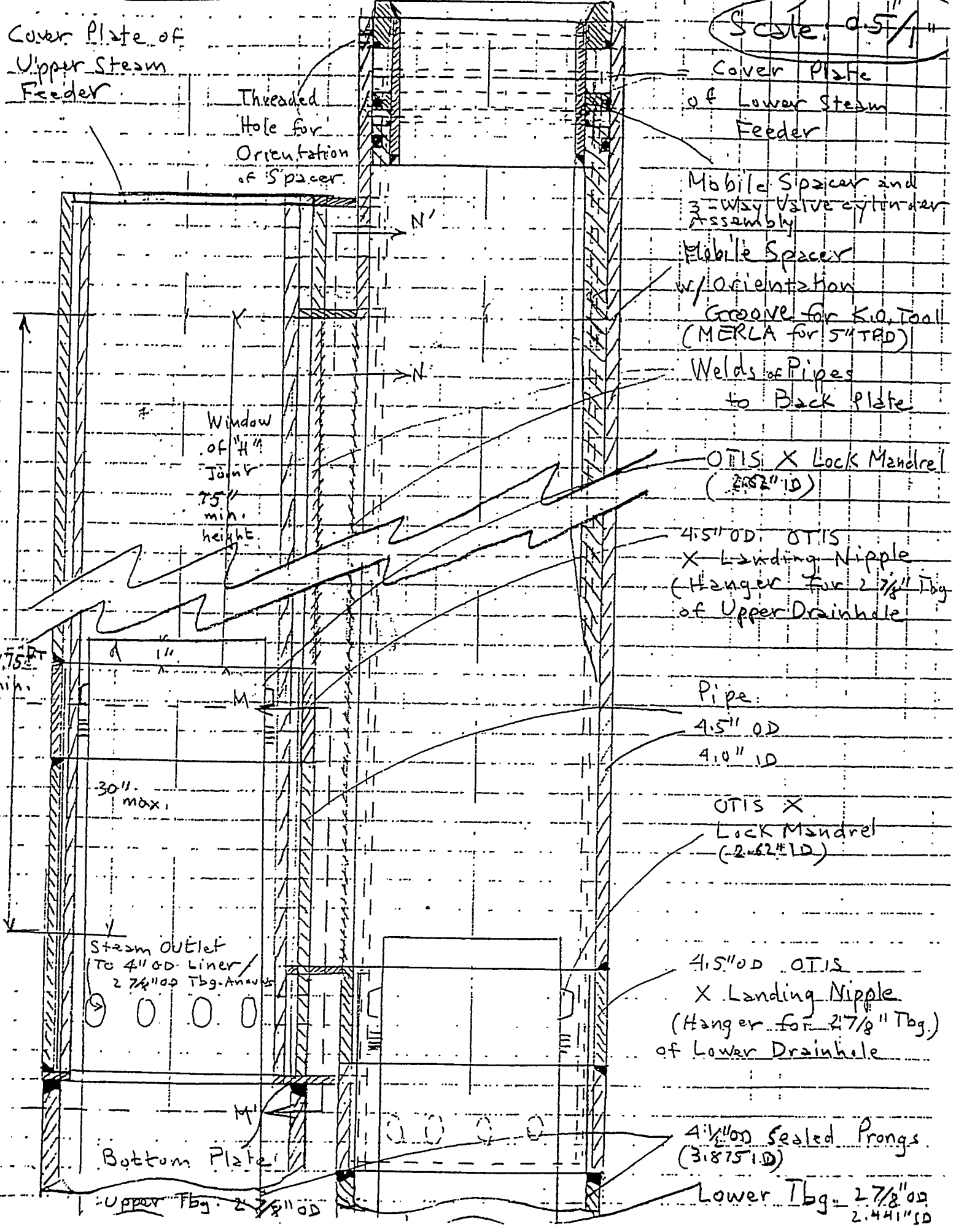

"H" JOINT SECTIONS (HORIZONTAL)

Positioned w/ respect to 10 3/4" casing
and 1 3/4" T.L.S.J

Scale: 1/4"

N'

Rod-Pump Tbg.
OD of VAM Spec. Coupling 2.76"
in T.L.S.J
and U.S.J } (11.75" OD)
17.05" ID

Lower
Steam Feeder

3.5" OD
Pipe

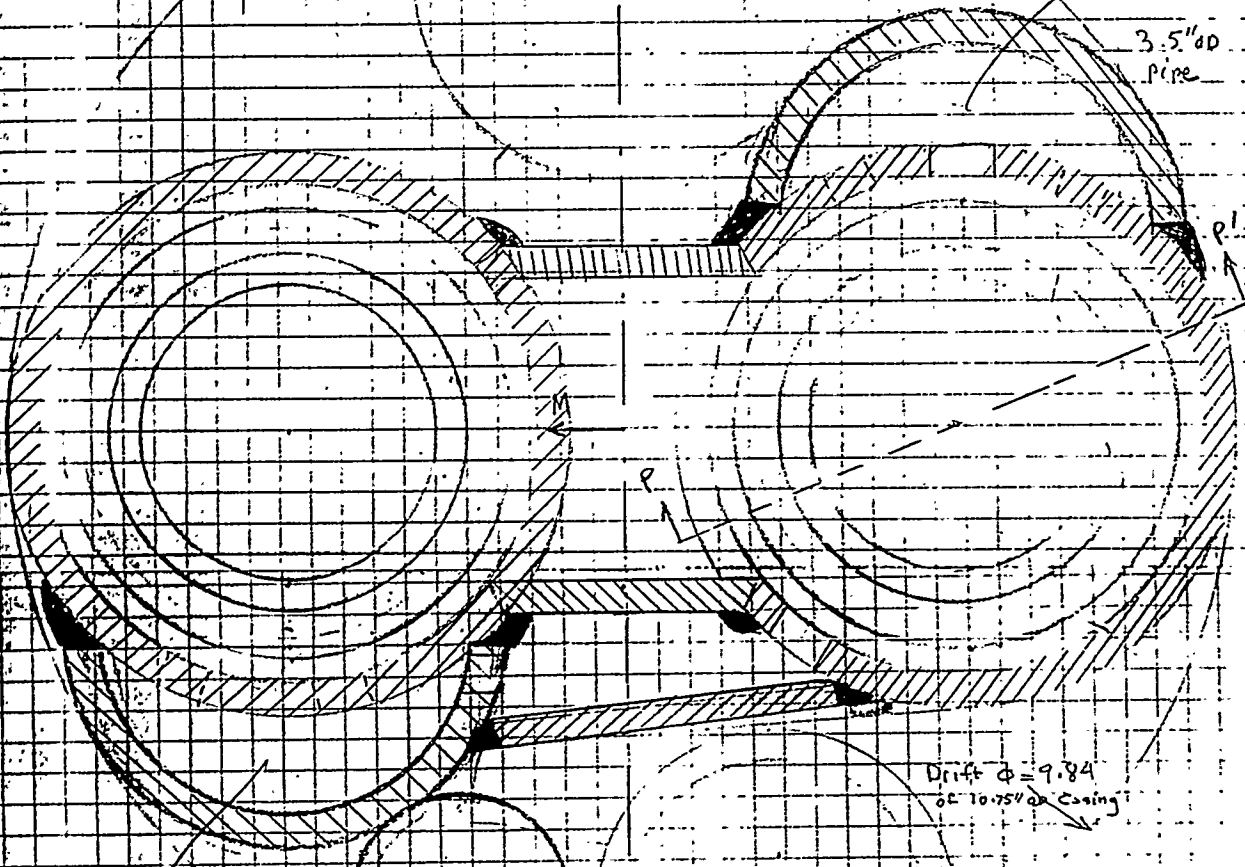

Upper
Steam Feeder
half of 3.5" OD pipe

1.65" ID
Hole
(Clean-Up)

Drift $\phi = 9.84$
of 10.75" OD casing

Production Tbg
seal bore in
T.L.S.J

LOOKING DOWN

M'

N'

LOOKING UP

LANDING NIPPLES AND LOCK MANDRELS SELECTIVE BY RUNNING TOOL

Otis X[®] and R[®] Landing Nipples and Lock Mandrels are designed to provide a degree of downhole selectivity. An operator can place as many selective nipples with the same I.D. as desired in the tubing string (without regard to a specific sequence) to provide an unlimited number of positions for setting and locking subsurface flow controls. Then one nipple can be selected that will be the best location for the flow control. If this location is unsatisfactory, or well conditions change, the flow control may be moved up or down the tubing string wherever another nipple is located—all by wireline under pressure without killing the well.

Otis XN[®] and RN[®] No-Go Landing Nipples and Lock Mandrels are designed for use in single nipple installations or as the bottom nipple in conjunction with a series of X or R Landing Nipples.

The landing nipples have the same packing bore I.D. for a particular tubing size and weight. Otis[®] X and XN Landing Nipples are designed for use with standard weight tubing. Otis R and RN Landing Nipples are for heavy weight tubing. The "N" designation is for no-go nipples.

BENEFITS OF DESIGN PRINCIPLE

Otis X and R Landing Nipples

- Maximum versatility to reduce completion and production maintenance costs.
- A large bore to permit maximum flow capacity. A nipple bore compatible with tubing size and weight is available when using either X or R nipples.
- Unequaled in simplicity/selectivity when running, setting or retrieving subsurface flow controls.
- Universal nipples with one internal profile (within

each type: X-standard weight tubing; R-heavy weight tubing) to serve as a preselected landing location for subsurface flow control equipment.

- Total traceability on each assembly.
- Complete documentation available with specified landing nipples.

Otis X and R Lock Mandrels

- Landing/locking keys are designed to be retracted to mandrel O.D. during running and pulling operations for faster wireline service.
- Wireline operator maintains control over locating, landing and locking in nipple of his choice. Nipple location may be selected before or after the mandrel and running tool are below the wellhead.
- Locking principle is designed to hold against pressure from either direction and sudden or repeated reversals of pressure.
- Inside fishing neck of both types of mandrels makes extra large I.D. possible for higher flow volumes.
- Complete documentation available with specified lock mandrels.

Otis XN and RN No-Go Landing Nipples and Lock Mandrels (Non-Selective)

- Designed for use in single nipple installations or as the bottom nipple in conjunction with a series of X or R Landing Nipples.
- Full-opening packing bore, with locking recess at top of nipple with a slightly restricted no-go profile at the bottom, designed to keep subsurface flow controls from being run below the tubing intake.
- Complete documentation available on specified landing nipples and lock mandrels.

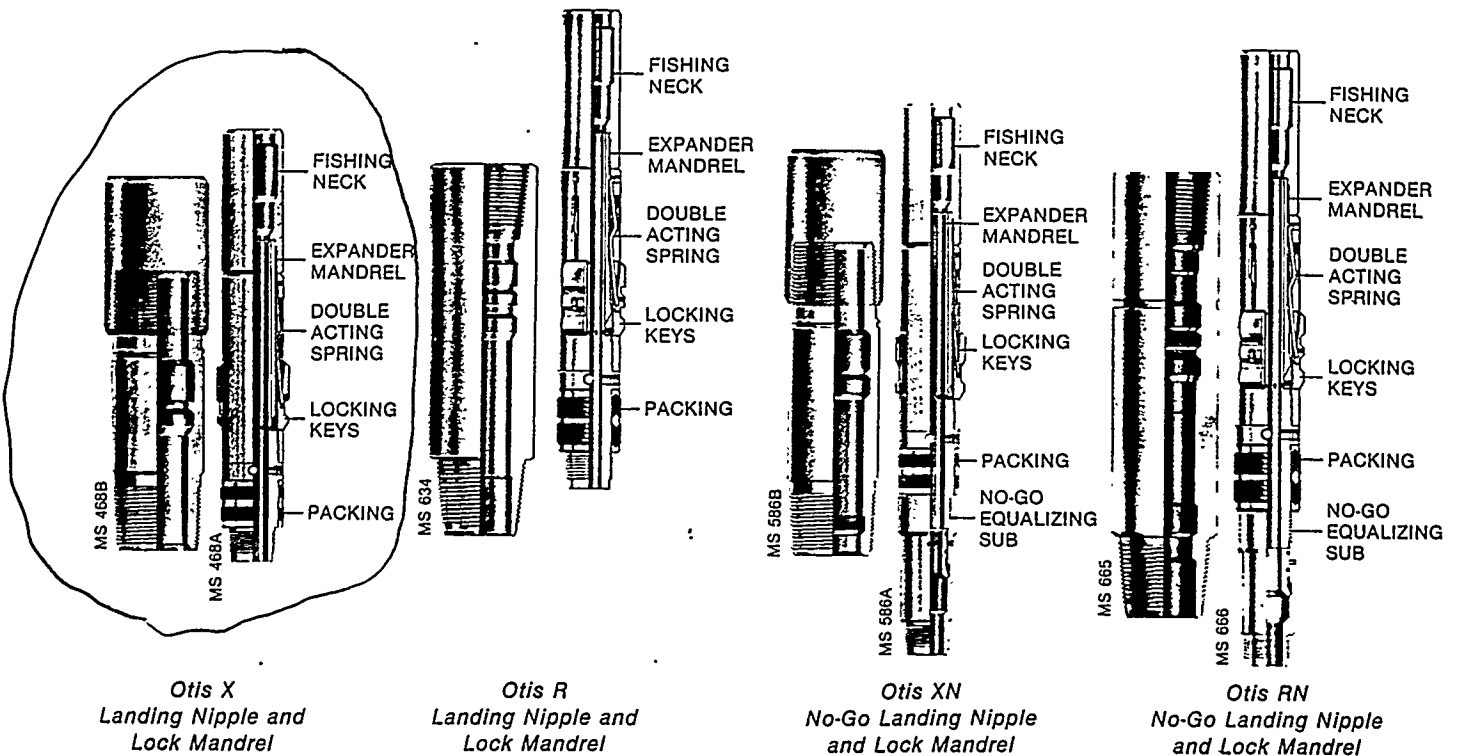

Steam Tubing

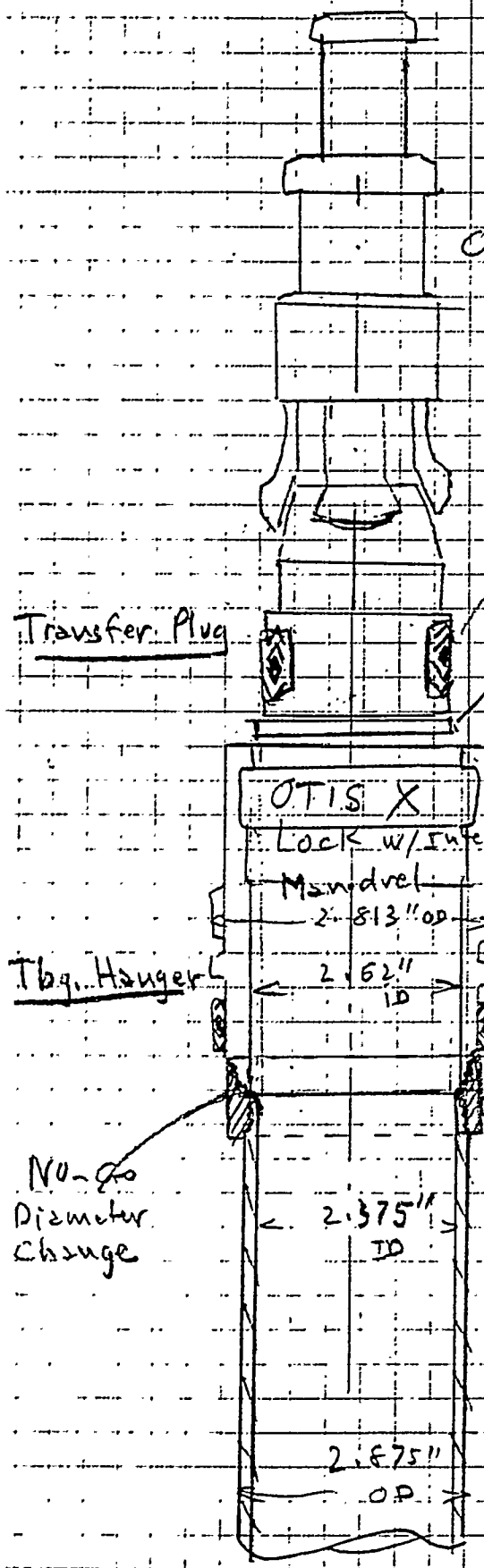

OTIS N
 Lock Mandrel for 2.875" tbg w/ plug
 2.313" OD stand seal must be replaced

Alternate
 Lock Mandrel for 3.5" tbg w/ Plug
 2.562" OD stand seal

Thicker Seal rings
 No-Go Ring 2.55" OD

Window 2.875" wide

OTIS X
 Landing Nippled 4.5" OD

Threaded adapter Ring

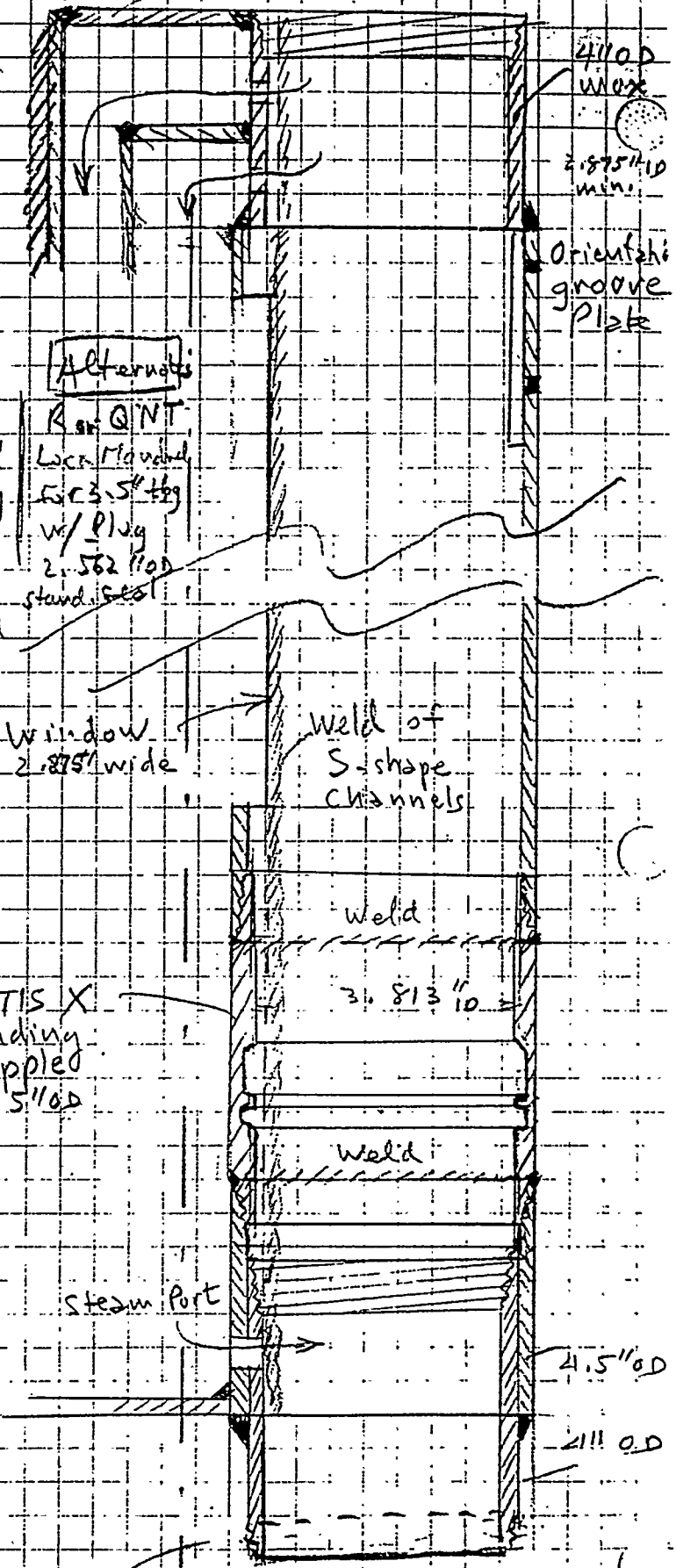

API Thread Compatible w/ PBR or 4" seal unit
 OTIS p. 50 + 49
 to fit w/ 5" OD receptacle

Steam Tubing

Transferable Plug within "H" Joint

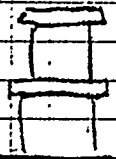

Transfer Plug

OTIS Tor Q Lock Mandrel for 1.900" Landing Nipple (OD = 1.438")

Retrievable Adapter

OTIS X (Intermediate Diameter) Lock Mandrel for 2.875" OD Landing Nipple (w/ thicker seals) $\Delta\phi = 0.30"$ ID = 1.50" increased from 1.38"

Tbg Hanger

2.62" ID OTIS X Lock Mandrel for 4.5" OD Landing Nipple

Alternate Solution

Substitute OTIS R Landing Nipple for 4.5" OD 16.9 #/ft (Facking Bare ID = 3.4)

2.875" O-D Tubing

Substitute OTIS R Lock Mandrel for 4.5" OD Tbg / 16.9 #/ft (OD = 3.4137" ID = 1.94")



Substitute OTIS S Lock Mandrel for 2.375" tbg (OD = 1.575") w/ thicker seals (can go through ID = 1.901")

Cheaper, but reduces access to 2.875" OD Tbg from 2.62" to 1.94" OK for 1 1/4" TOOLS

Steam Tubing

Three Way Steam Valve

— OTIS wireline retrievable sleeve assembly is only available for 3.5" OD tubing

— The retrievable sleeve is too big to go through a 1.901" ID tubing

Solution: Build an equivalent valve using OTIS X or R Landing Nipples + Mandrels for a 2.375"

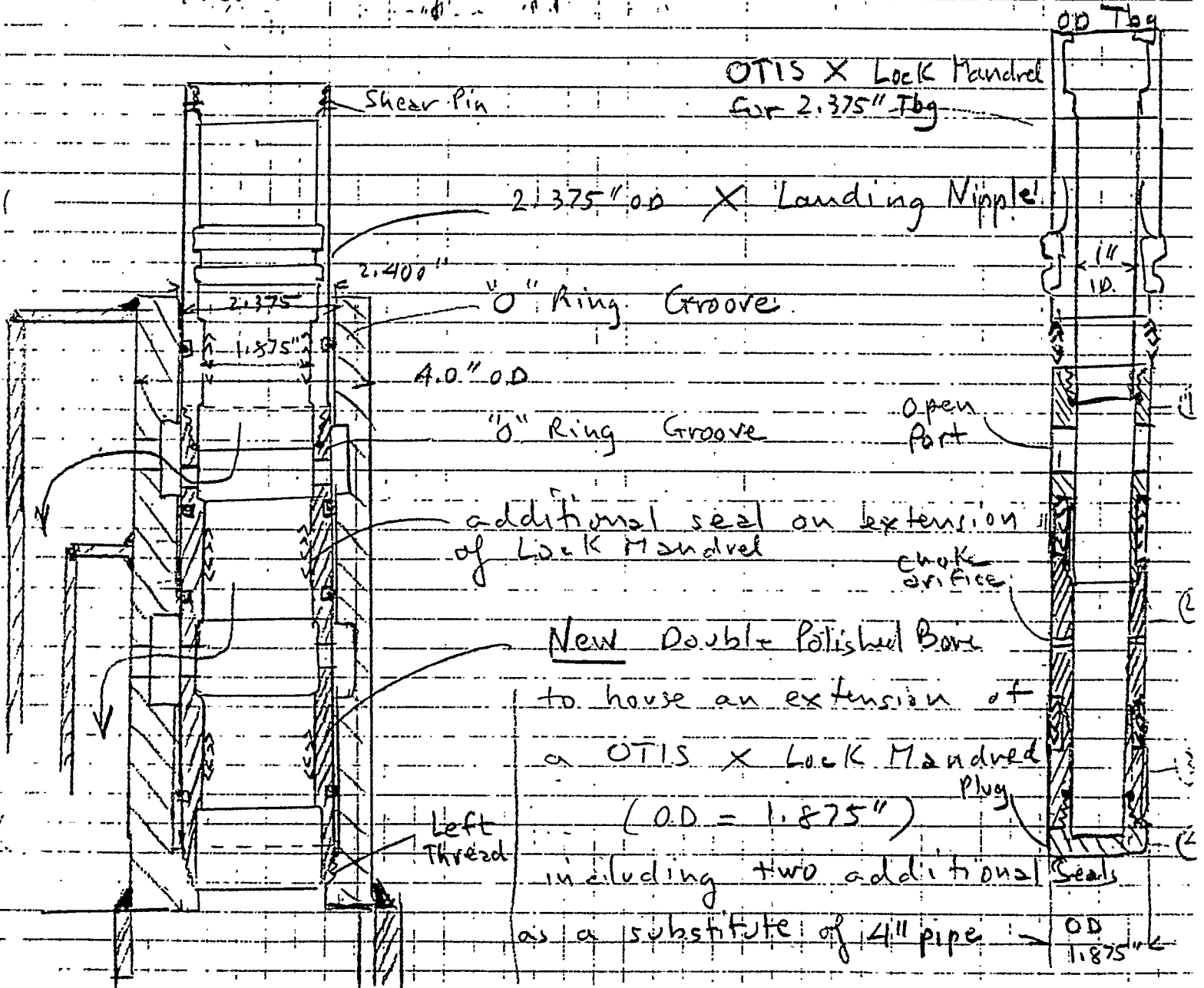

OTIS — The completion people... worldwide!

OTIS LANDING NIPPLES AND MANDRELS

TYPES X AND R (Selective by running tool) — TYPES XN AND RN NO-GO (Non-selective)

In this line of universal landing nipples and locking mandrels, Otis has achieved a new degree of downhole selectivity. Now, an operator can place as many nipples with the same I.D. as desired in his production string (without regards to a specific sequence) to provide an unlimited number of positions for setting and locking subsurface flow controls. Then, he can select the one nipple that will be the best location for his flow control. If this location is unsatisfactory or well conditions change, he can move the flow control up or down the well wherever another nipple is located... all by wireline under pressure without killing the well.

Nipples have same I.D. for a particular tubing weight as indicated. Type X and XN Nipples are available for use with standard weight tubing; Type R and RN Nipples for heavy weight tubing. The "N" designation is for no-go nipples.

BENEFITS OF DESIGN PRINCIPLE

Type X and R Landing Nipples

- Maximum versatility to reduce completion and production maintenance costs.
- A large bore to permit maximum flow capacity. A nipple bore compatible with tubing size and weight is available when using either Type X or Type R nipples.
- Unequaled in simplicity/selectivity when running, setting or retrieving subsurface flow controls.
- Universal nipples with one internal profile (within each type: X-standard weight tubing; R-heavy weight tubing) to

serve as a preselected landing location for subsurface flow control equipment.

Types X and R Locking Mandrels

- Landing and locking keys are designed to be retracted to mandrel O.D. during running and pulling operations for faster wireline service.
- Wireline operator maintains control over locating, landing and locking in nipple of his choice. Nipple location may be selected before or after the mandrel and running tool are below the bradenhead.
- Locking principle is designed to hold against pressure from either direction and sudden and/or repeated reversals of pressure.
- Inside fishing neck of both types of mandrels makes possible extra large I.D. for higher flow volumes and through-tubing work.

Types XN and RN No-Go Nipples and Mandrels (Non-Selective)

- Designed for use in single nipple installations or as the bottom nipple in conjunction with series of Type X or R Landing Nipples.
- Full-opening packing bore, with locking recess at top of nipple with a slightly restricted no-go profile at the bottom, designed to prevent some wireline tools from being run below the tubing and lost.

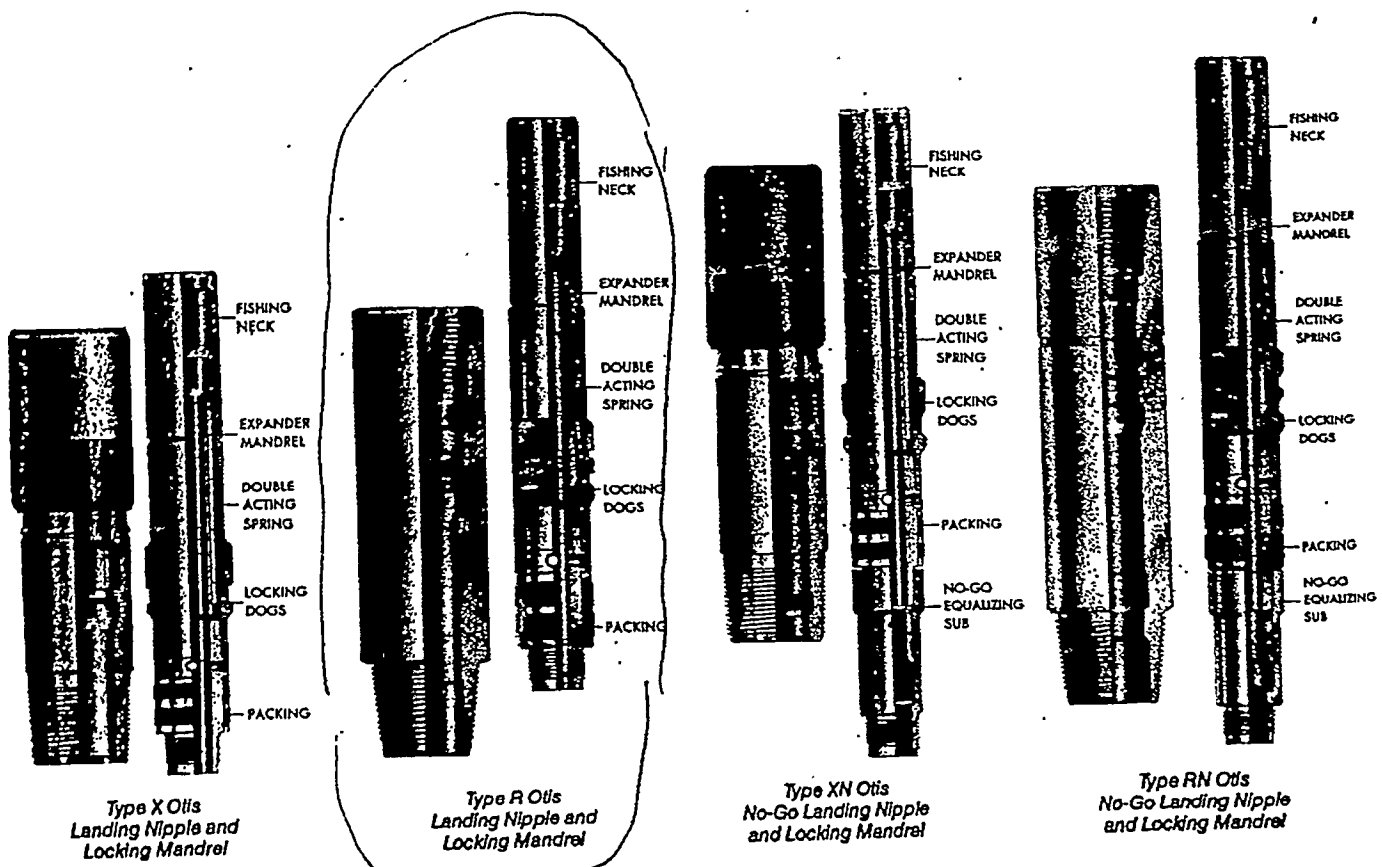

OTIS — The completion people... worldwide!

FIG. 2

GUIDE TO OTIS LOCKING MANDRELS

TYPE X (Selective) and TYPE XN (No-Go)
For standard tubing weight

LANDING NIPPLE Minimum Bore/Inches		MANDREL		
Selective	No-Go	I.D./ Inches	Packing O.D./ Inches	Pin Thread Down
.875	.850			
1.250	1.135	.625	1.250	7/8-20
1.500	1.448	.75	1.500	1-1/8-16
1.625	1.536	.75	1.625	1-1/8-16
1.875	1.791	1.00	1.875	1-3/8-14
2.313	2.205	1.38	2.313	1-3/4-12
2.750	2.635	1.75	2.750	2-1/4-12 SLB
2.813	...	1.75	2.813	2-1/4-12 SLB
3.313	3.135	2.12	3.313	2-3/4-12 SLB
3.813	3.725	2.62	3.813	3-1/16-12 SLB
4.313		available on request		
4.562	4.455	3.12	4.562	4-12 SLB

TYPE R (Selective) and TYPE RN (No-Go)
For Heavy Tubing Weight

LANDING NIPPLE Minimum Bore/Inches		MANDREL		
Selective	No-Go	I.D./ Inches	Packing O.D./ Inches	Pin Thread Down
.714	.638	.25	.714	1/2-20
1.125	1.012	.44	1.125	3/4-16
1.375	1.250	.62	1.375	7/8-20
1.500	1.345	.62	1.500	1-1/8-16
1.710	1.560	.75	1.710	1-1/8-16
1.781	1.640	.88	1.781	1-3/8-14
1.875	1.683	.88	1.875	1-3/8-14
2.000	1.796	.88	2.000	1-3/8-14
2.125	1.937	.88	2.125	1-3/8-14
2.188	2.010	1.125	2.188	1-3/4-12
2.313	2.078	1.125	2.313	1-3/4-12
2.562	2.329	1.375	2.562	2-12 SLB
3.125	2.907	1.940	3.125	2-5/8-12 SLB
3.250	3.088	1.940	3.250	2-3/4-12 SLB
3.437	3.162	1.940	3.437	2-3/4-12 SLB
3.688	3.455	2.38	3.688	3-1/16-12 SLB
4.000	3.748	2.38	4.000	3-1/16-12 SLB
4.125	3.912	2.75	4.125	3-1/4-12 SLB
4.313	3.987	2.62	4.313	3-1/4-12 SLB
4.562	4.455
5.963	5.750	3.75	5.963	5-1/16-8 SLB

**Types RQ (No-Go), RQL and RQP for
Safety-Valve Nipples for Heavy Tubing Weight**
(Illustrated on page 30)

LANDING NIPPLE Minimum Bore/Inches	MANDREL		
	I.D./ Inches	Pin Thread Down	No-Go Ring O.D./Inches
3.813	2.62	3-1/16-12 SLB	3.860
4.125	2.75	3-1/4-12 SLB	4.195
4.562	3.12	4-12 SLB	4.635
5.962	3.74	5-1/16-8 SLB	6.033

NOTE: Information on the complete lines of Otis equalizing subs, flow controls, running and pulling tools is available on request. Due to the type of service and pressure requirements of installations utilizing heavy-wall tubing, it is recommended that you contact your Otis representative or Otis Dallas headquarters for full data.

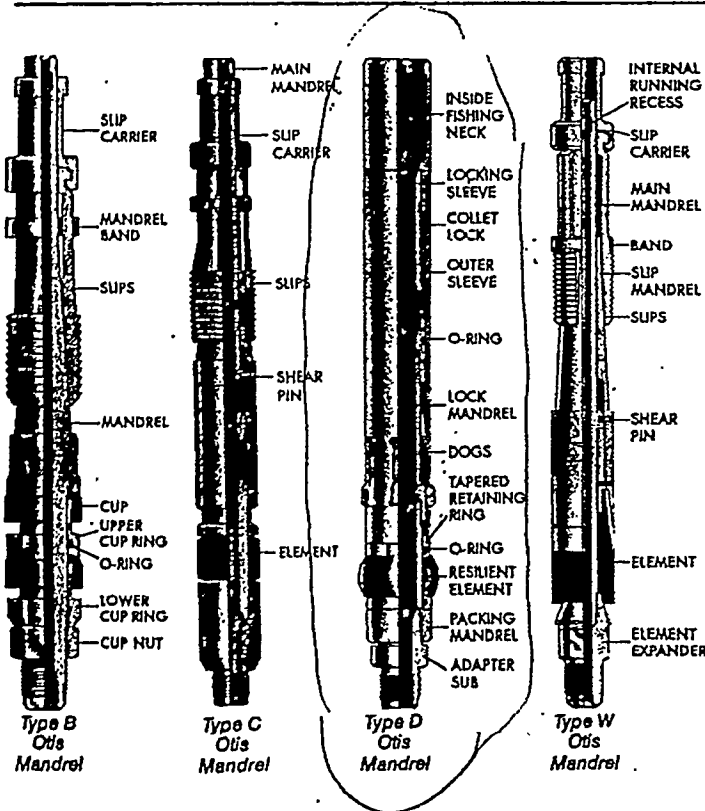

OTIS S SERIES NIPPLES AND MANDRELS

Type S Otis Landing Nipples are available with 7 different internal profiles. The selective locating keys of the locking mandrel are designed so they can be adjusted for locating only in the nipple with the matching position profile. Nipple/mandrel combinations are designed to withstand pressure from above or below. **Type N Otis Landing Nipple No-Go** is normally used in a single nipple installation or as the bottom nipple when used with a series of Type S Nipples.

OTIS SLIP-TYPE and COLLAR-LOCK MANDRELS

Otis furnishes two mandrel types designed to be used in wells not equipped with landing nipples. **Types B, C and W** are slip-type mandrels that are designed to be set and retrieved by wireline. **Type D** is a collar-lock mandrel that is designed to lock-in API tubing collars and pack-off. It is run and retrieved by standard wireline methods. Mandrel incorporates a mechanical-set, pressure energized sealing element and an extra large bore.

APPENDIX 3

DETAILED DRAWINGS, PHOTOGRAPHS AND SPECIFICATIONS OF KICK-OVER TOOL
(Tasks 1.3 and 1.7 Deliverables)

APPENDIX 3

(Tasks 1.3 and 1.7)

DESIGN AND SPECIFICATIONS OF THE KICK-OVER TOOL

Deliverables: a) Drawings and description of tool operation
(see Fig.1 to 5)

b) Key parameters

The key parameters of the tool are:

- the kick-over distance ($B - 0.75'' - 0.6''$)
- the minimum height of the T mandrel type in which it can be operated
- the dimensions of the orientation groove and Latch type

c) Available Range of existing tools

(see Dimensions of TPD for 5.5"OD tubing)

d) Specific tool for use with the "H" joint, as built

In the "H" joint the kick-over distance, in inches, is equal to:
 $5.375 + (2.375 / 2) = 6.562''$

For the TPD mandrel corresponding to a 5.5"OD tubing, it is:
 $7.75 - 0.75 - 0.6 = 7.75 - 1.35 = 6.40''$

The difference, $0.162''$, is the thickness of the spacer plate required in the "H" joint to line up the tool exactly above the center of the transferable lock mandrel. The spacer plate presents a slit of width and length compatible with the operation of the hook in the T2RAR Latch, used in this tool.

This design of the "H" joint allows the use, without any modification of the OTIS/Merla kick-over tool for TPD 5".

The same tool is also used for Mandrels corresponding to 5"OD tubing, for which the key parameter is:
 $7.48 - 1.35 = 6.13''$. This indicates the tolerance of the kick-over tool for a mis-alignment of $6.40 - 6.13 = 0.27''$. Accordingly, the thickness of the spacer plate in the "H" joint is not critical.

The minimum height of the "H" Joint, however, for use with this tool, is $A = 106''$.

The width of the window between the two bodies of the "H" joint must be large enough ($3.5''$) to easily get through it the smallest TM mandrel, for a 1"OD gas lift valve, located at the lower end of the 2.875"OD curved tubing when it is used for steam lift in the producing drainhole.

These are the conditions required to achieve full compatibility between the new "H" joint and the existing OTIS/Merla tools.

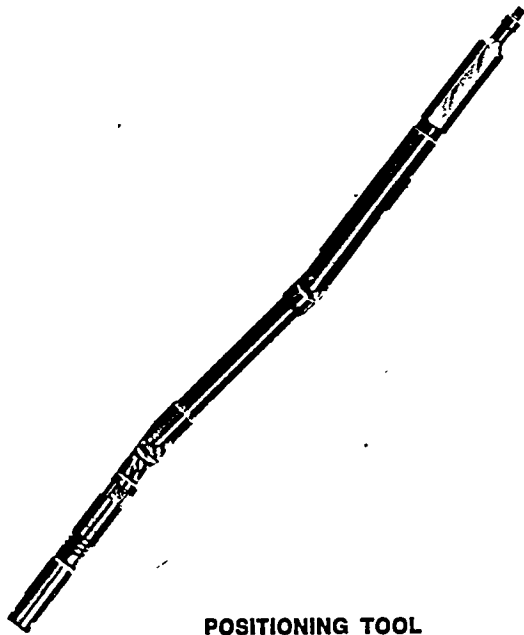

POSITIONING TOOL

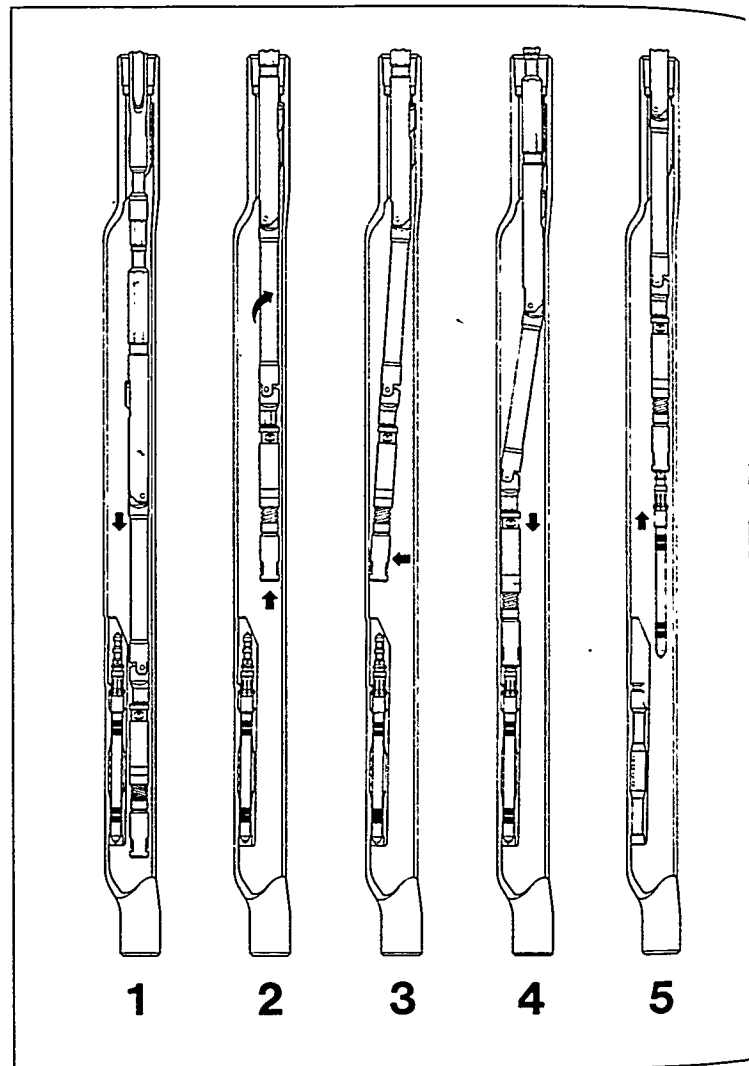

POSITIONING TOOL (PAT. # 3,876,001)

DESCRIPTION

To complement the T and TM Series mandrels, Merla developed the T Positioning Tool to make wireline work more effective, particularly in deviated wells. Ease of operation is a definite aid to wireline operators with limited experience.

The positioning tool, when used with TP or TMP mandrels, performs three very important functions: (1) locates the mandrel, (2) orients in the proper azimuth and (3) laterally offsets the valve or pulling tool into position over the pocket for setting in or pulling from the mandrel.

ADVANTAGES

Operation of the tool is not complicated and design features have been incorporated to make it easy to service and practical to use. For example, only the shear pin in the locator key must be replaced after each trip. Pin replacement requires no disassembly and may be performed easily with the tools hanging in the lubricator. Running and pulling, therefore, can be accomplished rapidly. Once the locator key pin is sheared as the valve is either set or pulled, the tool locks in a rigid position and may be raised or lowered past other mandrels—a very important feature in the event of a fishing job. The outside profile plus internal porting provides ample fluid bypass to insure rapid running and pulling without swabbing.

The shortness of the tool also means that rig-up time is reduced since an extra long lubricator is not required.

The tool is available on a purchase or rental basis.

OPERATION

1. The tool is run below the mandrel. Since the tool is locked in a rigid position, it cannot kick over accidentally.
2. The operator slowly raises the positioning tool until the key of the tool engages the orienting sleeve in the mandrel. Further upward movement causes the positioning tool to rotate until the key enters the slot. When the key reaches the top of the slot, the operator receives an indication on the weight indicator.
3. The positioning tool is now properly oriented. The operator pulls an additional strain on the line of 200 lbs. (90 kg.) above the free weight of tools and line. This strain forces the pivot arm to swing out and lock in position. The valve or pulling tool is now located just above the pocket or latch.
4. Once the tool is locked in the offset position, a valve may be installed or removed with the internal shape of the mandrel accurately guiding the tools.
5. Removal of the tool is accomplished when the shear pin is sheared as the key reaches the top of the slot. This action allows the trigger to glide freely out of the slot and thru the tubing. When the pivot arm reaches the small upper section of the mandrel, it snaps back and locks into the vertical position; thus, there is no drag on the tool or valve as it is removed from the well.



LAT

APPI

The
a mir
recess
prevent
collet
Upward
to m
locke
and
deflec
Th
in an
be us
the R
Th
mini
rotat
retrie
liftec
Th
cont:
Th
the I
R is
the I
Th
in C
360°
* 1

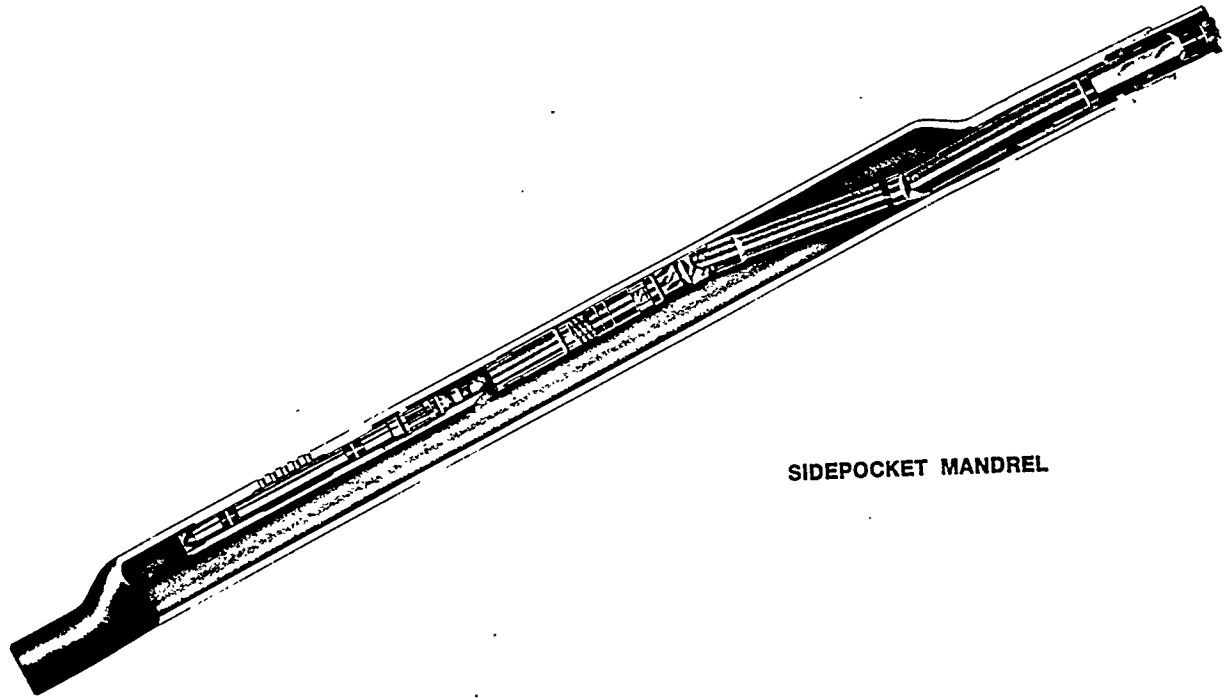
SIDEPOCKET MANDREL
SIDEPOCKET MANDRELS (PAT. # 3,994,339)
NEW CONCEPTS IN SIDEPOCKET MANDRELS

The T and TM Series mandrels complemented with Merla's Positioning Tools are major improvements in well completion equipment. These tools bring our industry three distinct improvements.

External Shape—A new configuration that provides a new dimension in running clearance.

Internal Guide—An internal profile that guides the valve into the pocket but excludes larger tools from the offset section.

Positioning—A new positioning sleeve and positioning tool for positive location and orientation in deviated wells.

APPLICATIONS

Sidepocket mandrels have primary application as receivers for retrievable gas lift valves. With a valve in place, the mandrel provides a full drift bore permitting wireline operation through the mandrel. Mandrels with dummy valves in place may be installed at the time of initial well completion even though the gas lifting operation may be several years in the future. The mandrel then becomes an integral part of the tubing with full assurance of a leak-free tubing string. When the gas lift phase is necessary, the dummies can be pulled and gas lift valves installed via wireline operations. Valves may be selectively retrieved or installed.

Exact standards are maintained during manufacture of the mandrel. Stresses set up in the mandrel during forging and welding processes are eliminated by heat treating the mandrel in a controlled atmospheric furnace. A heat treat cycle for the best balance between strength and corrosion resistance has been established. The mandrel has a tensile strength in excess of N-80 tubing. A special low hardness heat treat cycle is available to provide the best service in H₂S. Merla employs special manufacturing techniques to assure that the seal bores in the pocket are of high quality finish. Quality seal bore finishes help to eliminate problems encountered in retrieving valves, particularly in wells with sandy conditions and high temperatures. Each mandrel is rigorously inspected. Mandrels are pressure tested and drifted to tubing drift or larger. Exterior dimensions are held to very close tolerance.

NOMENCLATURE

The T Series mandrel is made in two basic configurations. The TM receives 1" (2.54 cm) valve and the T receives 1½" (3.81 cm) valve. Other letters used to designate accessory items and pocket portings:

P—denotes a positioning sleeve incorporated in the mandrel. This sleeve is located at the top of the mandrel and serves as a guide and positioner for the Merla positioning tool.

D—designates a deflector is built into the mandrel. The deflector conceals the latch and prevents tools larger than the pulling tool from entering the latch recess.

C—designates that the mandrel is ported for casing flow service. The pocket is ported between the seal bores to communicate with the mandrel's internal fluids. This configuration has a circulation path down the tubing and into the casing by means of the mandrel pocket outlet porting.

E—designates external outlet porting or a chamber mandrel. The bottom of the pocket is ported to the outside where a ¾" (1.90 cm) pipe may be connected. This configuration allows the use of the mandrel for chamber lift operation or other special application where the discharge of the gas lift valve may be directed through the ¾" (1.90 cm) external pipe instead of into the tubing string.

S—designates service or waterflood mandrel. There are no ports between the seal bores. It is used for service wells to put gas or liquids from the tubing into the casing, water flood, gas storage or fluid disposal.

SS—denotes a side string is attached to the external porting of the mandrel. This mandrel is used where gas is carried down the side string to the mandrel between straddle packers or below packers where very thick reservoirs are being produced.

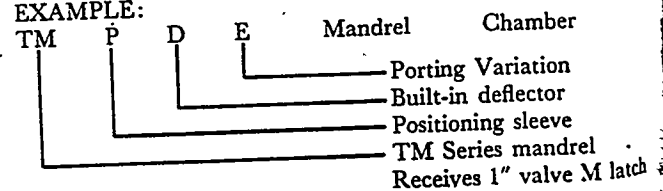
EXAMPLE:

BASIC MANDREL CONFIGURATION

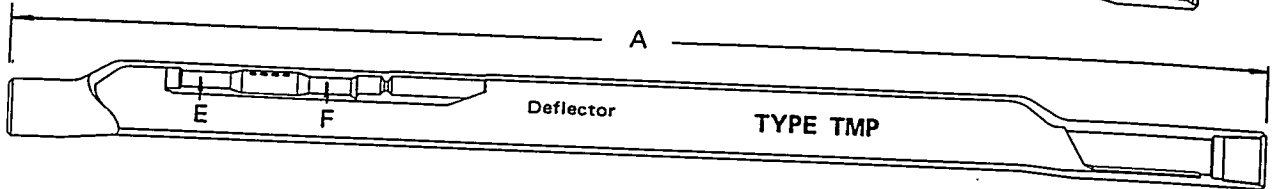
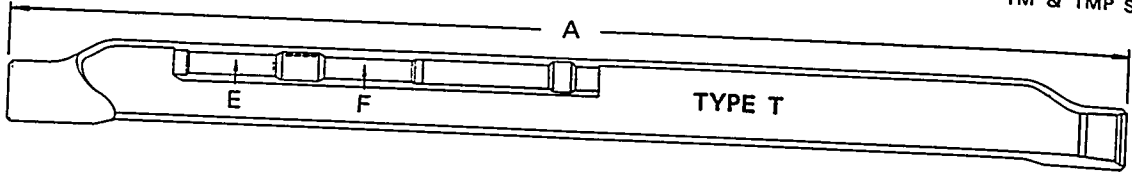
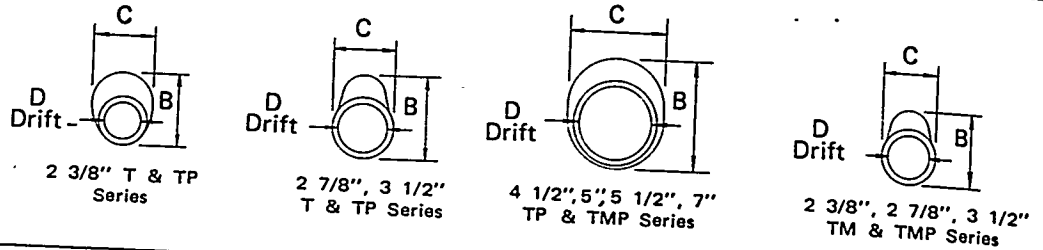

PORTING VARIATIONS

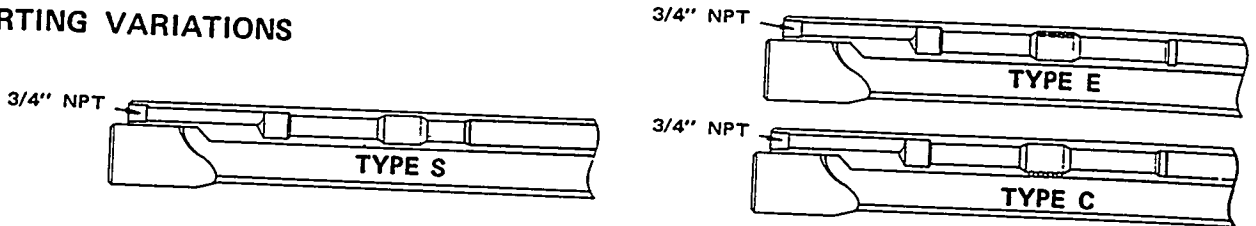

Tbg. OD 8Rd EUE	TM Mandrel Types	Dimensions — Inches (CM)						Weight Lbs./Kg.	
		A	B	C	D	E	F		
2 1/4 (6.03)	NUE (6.03)	TMX, TMXC, TMXS	64 (143)	3.875 (9.84)	2.90 (7.34)	1.901 (4.81)	1.027 (3.23)	1.027 (3.23)	60/27
2 1/2 (6.03)	TM, TME, TMC, TMS	63 (138)	4.250 (10.79)	2.90 (7.34)	1.901 (4.81)	1.027 (3.23)	1.027 (3.23)	62/28	
2 3/4 (7.30)	TM, TME, TMC, TMS	73 (153)	4.250 (10.79)	2.90 (7.34)	1.901 (4.81)	1.027 (3.23)	1.027 (3.23)	64/29	
2 7/8 (7.62)	TMP, TMPE, TMPC, TMPS	73 (153)	4.750 (12.06)	3.56 (9.04)	2.375 (6.03)	1.027 (3.23)	1.027 (3.23)	74/33.5	
3 (7.62)	TM, TME, TMC, TMS	64 (143)	5.620 (14.28)	4.37 (11.11)	2.875 (7.30)	1.027 (3.23)	1.027 (3.23)	90/40.6	
3 1/2 (10.16)	TMP, TMPE, TMPC, TMPS	75 (157)	5.850 (14.88)	5.00 (12.70)	3.351 (8.51)	1.027 (3.23)	1.027 (3.23)	106/48.9	
4 (10.16)	TMP, TMPE, TMPC, TMPS	75 (157)	6.050 (15.36)	5.18 (13.17)	3.375 (8.57)	1.027 (3.23)	1.027 (3.23)	117/53.9	
4 1/2 (11.43)	TM, TME, TMC, TMS	64 (143)	6.620 (16.72)	5.54 (14.08)	3.833 (8.59)	1.027 (3.23)	1.027 (3.23)	142/65.2	
4 3/4 (11.43)	TMP, TMPE, TMPC, TMPS	77 (161)	6.620 (16.72)	5.54 (14.08)	3.833 (8.59)	1.027 (3.23)	1.027 (3.23)	185/84.5	
4 7/8 (11.43)	TMP, TMPE, TMPC, TMPS	77 (161)	6.620 (16.72)	5.54 (14.08)	3.833 (8.59)	1.027 (3.23)	1.027 (3.23)	185/84.5	

Addition of deflector does not alter dimensions above.
 Pocket configuration on the TM mandrel has been modified to accept either the M, BK or bottom collet latch. This pocket has been designated as the TM-3 pocket and is so stamped on the pocket. The pocket stamped TM-2 accepts either the M or bottom collet and the pocket with no stamp accepts only the M latch.

Tbg. OD 8Rd EUE	T Mandrel Types	Dimensions — Inches (CM)						Weight	Latch
		A	B	C	D	E	F		
2 1/4 (6.03)	T, TC, TE, TS	101 (212.5)	4.750 (12.06)	4.00 (10.16)	1.901 (4.81)	1.496 (12.40)	1.558 (3.93)	130 (58.6)	T2, RA, R*
2 1/2 (6.03)	TP, TPC, TPE, TPS	110 (230.5)	4.750 (12.06)	4.00 (10.16)	1.901 (4.81)	1.496 (12.40)	1.558 (3.93)	130 (58.6)	T2, RA, R*
2 3/4 (7.30)	T, TC, TE, TS	100 (210.0)	5.460 (13.89)	4.00 (10.16)	2.375 (6.03)	1.496 (12.40)	1.558 (3.93)	165 (74.3)	T2, RA, R*
2 7/8 (7.30)	TP, TPC, TPE, TPS	110 (230.5)	5.460 (13.89)	4.00 (10.16)	2.375 (6.03)	1.496 (12.40)	1.558 (3.93)	165 (74.3)	T2, RA, R*
3 (7.62)	T, TC, TE, TS	100 (210.0)	5.960 (15.16)	4.37 (11.11)	2.875 (7.30)	1.496 (12.40)	1.558 (3.93)	175 (79)	T2, RA, R*
3 1/2 (7.62)	TP, TPC, TPE, TPS	110 (230.5)	5.960 (15.16)	4.37 (11.11)	2.875 (7.30)	1.496 (12.40)	1.558 (3.93)	175 (79)	T2, RA, R*
4 (10.16)	TPD	105 (220.5)	6.630 (15.39)	5.00 (10.5)	3.352 (7.2)	1.496 (12.40)	1.558 (3.93)	225 (101.4)	T2, RA, R*
4 1/2 (11.43)	TPD, TPDC, TPDE, TPDS	105 (220.5)	7.060 (17.81)	6.00 (15.24)	3.833 (8.59)	1.496 (12.40)	1.558 (3.93)	235 (106.2)	T2, RA, R
5 (12.70)	TPD	104 (218.4)	7.480 (19.66)	6.56 (16.66)	4.28 (10.87)	1.496 (12.40)	1.558 (3.93)	243 (109.5)	T2, RA, R
5 1/2 (13.97)	TPD	106 (222.6)	7.750 (19.68)	6.78 (15.83)	4.560 (10.30)	1.496 (12.40)	1.558 (3.93)	295 (133)	T2, RA, R
7 (17.78)	TPDX Vam	110 (230.5)	8.300 (20.40)	8.30 (20.40)	5.000 (12.70)	1.496 (12.40)	1.558 (3.93)	320 (136.9)	T2, RA, R

* R Latch to be used in "S" porting variation mandrels only.
 Pockets on sizes 4 1/2" (11.43 cm) T and larger have been modified to accept R and RA latches as well as T2 latch. These mandrels carry a "T-2" stamp. Mandrels larger than 4 1/2" (11.43 cm) carrying no stamp will accept only T2 latches. Sizes smaller than 4 1/2" (11.43 cm) have always accepted R, RA and T2 latches.
 Positioning Sleeves and Deflectors are standard on 4 1/2" Mandrels and larger optional on all Mandrels.

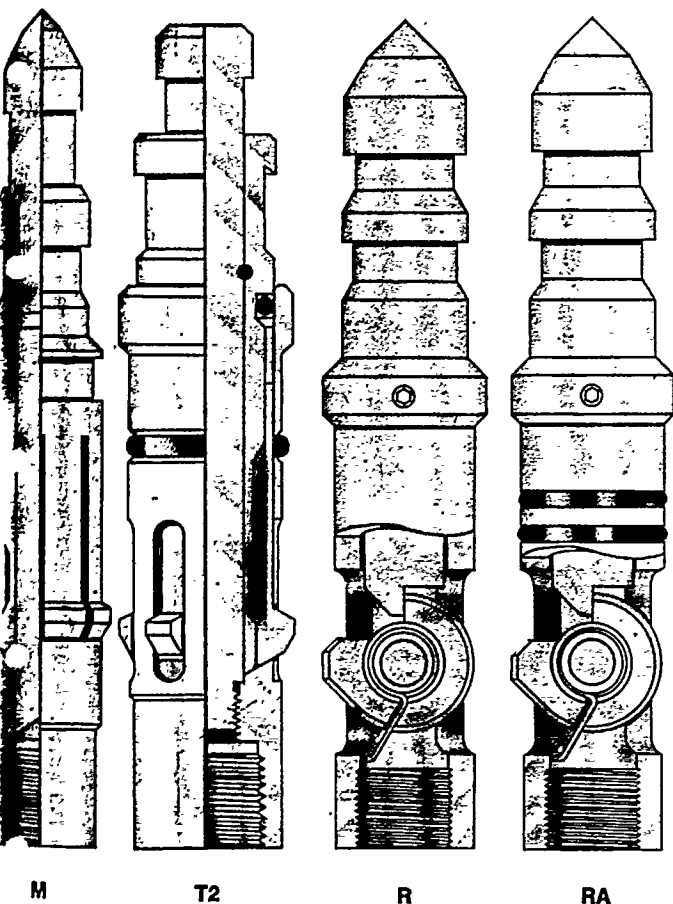

LATCHES

APPLICATIONS

The M* and T2 latches are collet latches designed so that minimum force is required to pass the collet into the lock recess. This feature is very important where deviated wells prevent forceful downward jarring. During installation, the collet moves up and deflects as it passes the lock recess. Downward movement to shear the running tool causes the collet to move into the position illustrated where it is securely locked. When pulling the latch, the shear pin is sheared and allows the latch body to move upward and the collet to deflect and pass out of the lock recess.

The M latch may be used in all TM Series mandrels and any pocket that accepts the BK latch. The T2 latch may be used in the T Series mandrels or any pocket that accepts the M or TA latch.

The RA and R latches also may be installed with a minimum force. The locking mechanism is a spring-loaded rotating cam that locks in the pocket locking recess. When retrieving, a shear pin is sheared and the latch release pin is rotated to allow the latch cam to rotate freely out of the way.

The RA and R latches are identical in function. The RA latch contains two exterior O-ring seals and a shorter cam nose.

These latches are used in all T Series mandrels. Normally, the RA is used in all cases except the TS mandrel when the M is used. The RA is also used in all MMA mandrels and the R in all MM and MMS mandrels.

The T2 latch may be used in place of the R or RA latch in C, E and S ported mandrels to utilize its inherently stronger latch retention.

U.S. Patent No. 3,741,601

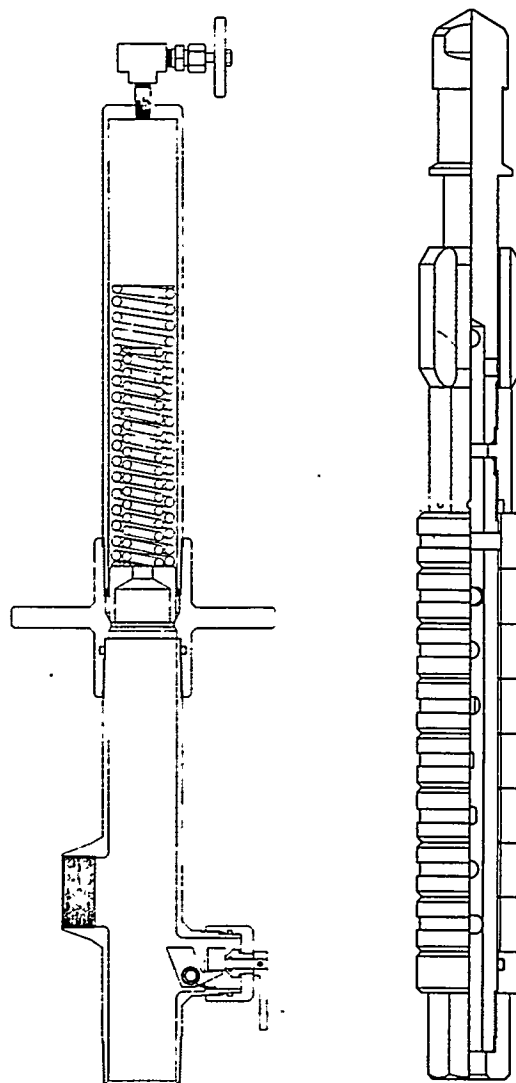

TYPE A-1

TYPE H-4

TYPE A-1 CATCHER BUMPER ASSEMBLY

This assembly provides all the wellhead requirements for a plunger installation. It may be installed directly above the tubing valve and has a flow line outlet connection. The assembly contains a heavy duty bumper to prevent plunger damage and an automatic catcher to enable the operator to catch the plunger when desired. The O-ring seal hand grip collar makes plunger inspection simple—without special tools.

TYPE H-4 The H-4 is a heavy duty plunger that provides a maximum seal in the tubing with a minimum friction drag. Two seals are incorporated—the piston section and the sliding sleeve valve. The sliding sleeve valve provides a means for the plunger to fall faster. When the plunger starts down, the sleeve moves up exposing the bypass holes. When the plunger stops, the sleeve valve moves down effecting a seal of these holes. The piston section consists of 8 slip ring pistons, each actuated by a pressure button. The differential pressure across the plunger causes these buttons to actuate and press the slip ring out against the tubing walls. Since each button is set at an angle from the button above, each slip ring is pushed out at a different azimuth thus forming a perfect circle contact with the tubing walls without creating excess friction.

APPENDIX 4

DETAILED DRAWINGS AND PHOTOGRAPHS OF 3-WAY SLIDING VALVE

a) Wireline Operated

b) Hydraulically Operated

(Tasks 1.4 and 1.8 Deliverables)

APPENDIX 4

(Tasks 1.4 and 1.8)

DESIGN AND CONSTRUCTION OF A WIRELINE RETRIEVABLE THREE-WAY STEAM VALVE

The valve body is threaded into the 4.5"OD upper branch pipe of the "H" Joint. This pipe diameter is required to run-in the 2.875" curved tubing with a TMX gas lift mandrel at its lower end.

The valve body consists of a short 2.375" OD VAM nipple equipped with two welded plugs of 4.0"OD, each one with an "O" ring seal. It is threaded into the bottom of an OTIS X Landing nipple for a 2.375"OD tubing, with a welded and threaded cap also equipped with an "O" ring seal.

The retrievable sliding sleeve, also equipped with two "O" ring seals, consists of two interchangeable sleeves threaded into the bottom of an OTIS X Lock mandrel for a 2.375"OD tubing. The sleeves assembly is closed at its lower end by a threaded plug and the size of the ports in each sleeve determines whether the lift steam is directed toward the bottom chamber while the injected steam is conveyed to the top chamber, or vice versa.

Once locked in place, all the seals on the sleeve remain static, for a longer life, at least equal to the steam injection cycle duration.

Nitrile rubber "O" rings have been proved to work well with steam under those conditions by the MS thesis work done by S.M. Zeyrek at UC Berkeley.

THREE-WAY STEAM VALVE / STEAM FEEDER

Section I-P-P of 1" H Joint

Scale: 1/1

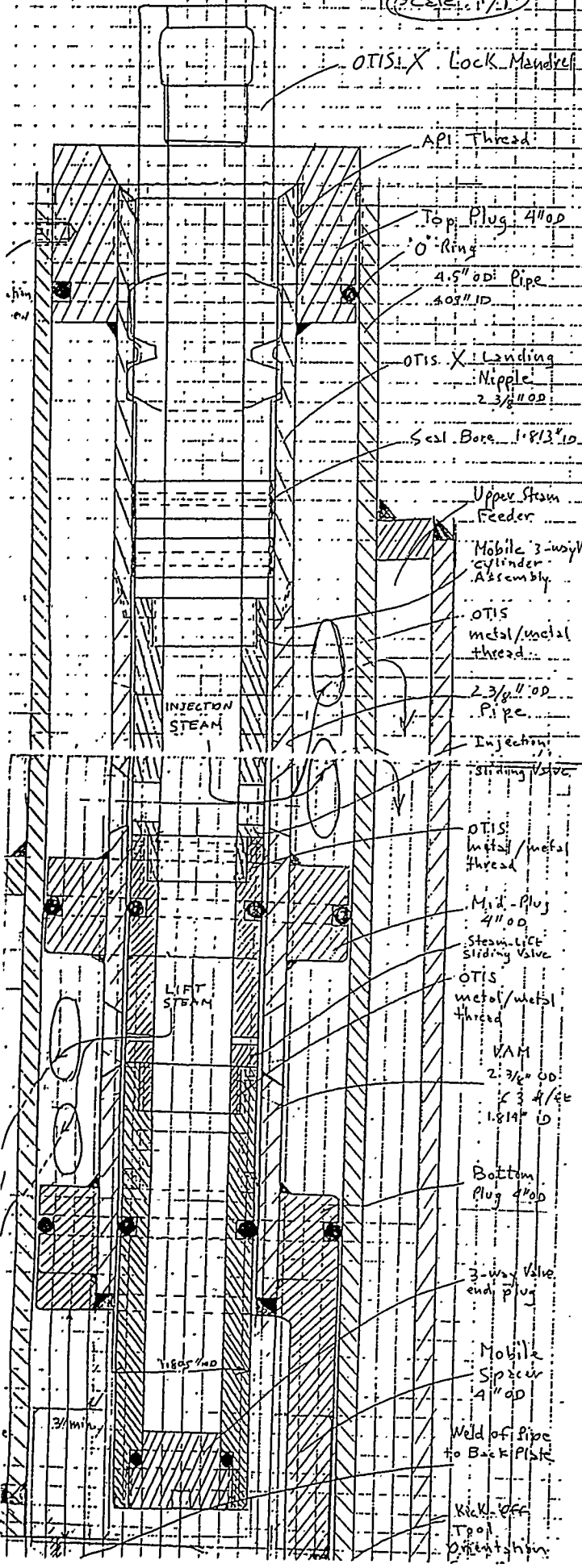

OTIS X Lock Mandrel

API Thread

Top Plug 4" OD

O-Ring

4.5" OD Pipe
4.09" ID

OTIS X Landing
Nipple
2 3/8" OD

Seal Bore 1.813" ID

Upper Steam
Feeder

Mobile 3-way
cylinder
Assembly

OTIS
metal/metal
thread

2 3/8" OD
Pipe

Injection
sliding Valve

OTIS
metal/metal
thread

Mid-Plug
4" OD

Steam Lift
Sliding Valve

OTIS
metal/metal
thread

VAM
2 3/8" OD
3 1/4" ID
1.814" ID

Bottom
Plug 4" OD

3-way Valve
end plug

Mobile
Spacer
4" OD

Weld of Pipe
to Back Plate

3/4" min

Kick Off
Tool
Orientation

INJECTION
STEAM

LIFT
STEAM

ANNULAR VENT SLEEVE VALVE FOR ECHO-2 SYSTEM

Otis® Annular Vent Sleeve Valve is designed to provide communication between the casing annulus and the producing formation. The valve is basically a hydraulically-operated SLIDING SIDE-DOOR® device. Its design principle is similar to a surface controlled subsurface safety valve: a hydraulic piston is opposed by a power spring to maintain the valve in a normally-closed position. The valve can be used with a bull plug on top and serve as an annular safety valve, providing annular bypass while control pressure is applied. The valve can also be used with an electrical feed-through device. This application provides two functions through a single packer mandrel—electric power cable passage and annular bypass. The Otis Echo-2 System consists of an Otis dual packer and Annular Vent Sleeve Valve.

BENEFITS OF DESIGN PRINCIPLE

- Versatile design allows use in gas lift installations as well as electric submersible pump applications. Valve will shut off flow from either direction—production or injection.
- Maximum gas vent flow area allows increased gas flow rates and lower circulating pressures.
- In emergency situations, can be pumped through without control line pressure for circulation or kill operations.
- Vent gas and electric pump cable utilize same packer bore.
- Tubing-retrievable or wireline-retrievable subsurface safety valves can be used with this safety system.
- Accurate fluid-level shot during pumping, due to large ported area through the ECHO-2 vent sleeve. Cable/vent bore through packer must have adequate clearance area around cable to obtain quality fluid-level shot.

OPERATING PRINCIPLE

The valve is made up on a dual hydraulic packer and may be operated by a common hydraulic control line used to set the packer and operate the tubing-retrievable safety valve. Hydraulic pressure from the control line shifts the valve open to create a flow path across the packer in the annulus. Spring force closes the valve upon loss of control line pressure to the piston. If the valve becomes inoperable or closed, an emergency shear sub orifice closing sleeve

ANNULAR VENT SLEEVE VALVE

SIZE (IN, mm)	2.500	63,50
CONNECTION	2 1/4" EU	2 1/4" EU
CONTROL LINE CONNECTION	1/4" NPT	1/4" NPT
ECCENTRIC OD (IN, mm)	4.14	105,16
CONCENTRIC OD (IN, mm)	3.70	93,98
ID (IN, mm)	2.20	55,88
FLOW AREA (IN ² , cm ²)	3.44	22,19
WORKING PRESSURE (PSI, kg/cm ²)	3000	211
TEMPERATURE RATING (°F, °C)	20 to 250	-7 to 121
CLOSING PRESSURE (PSI, kg/cm ²)	437	31
MAXIMUM RECOMMENDED SETTING DEPTH (FT, m)	1000	304,80

Additional Sizes Available Upon Request.

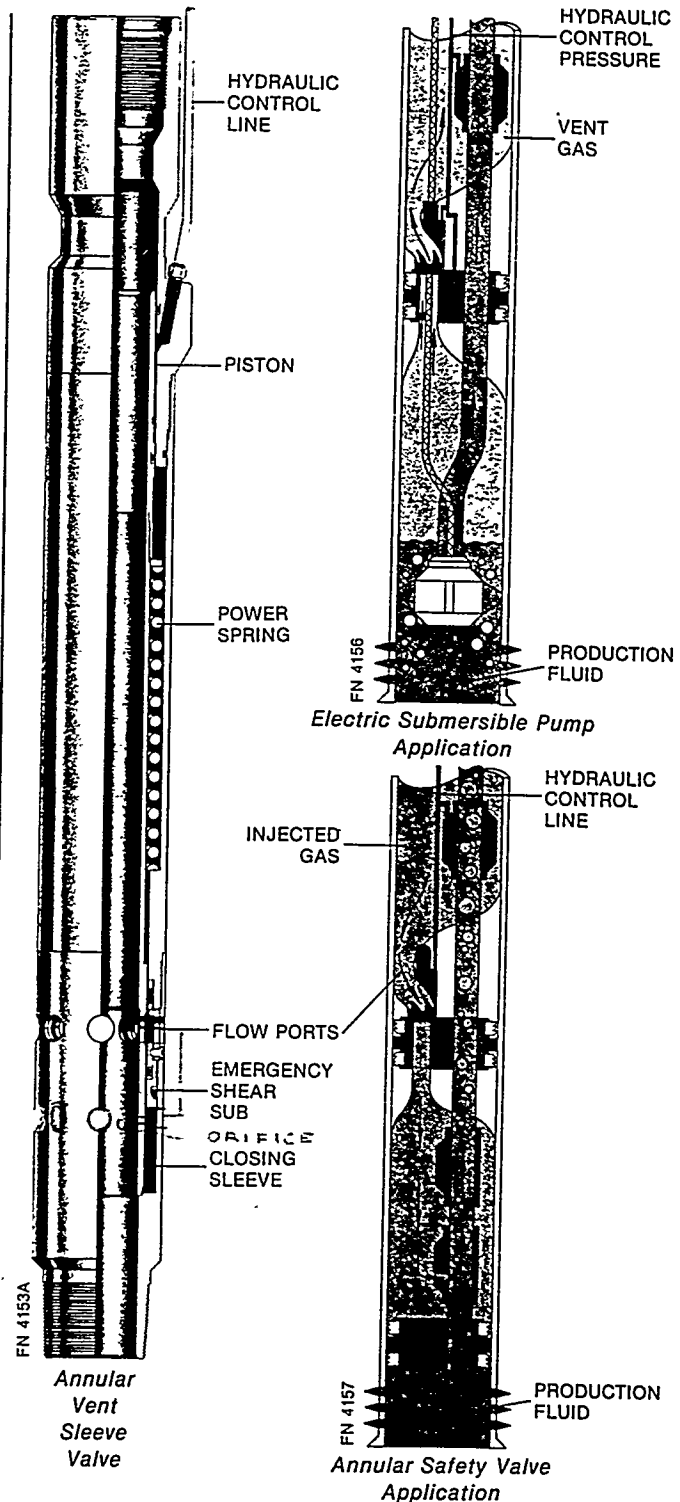

HOW TO ORDER - ANNULAR VENT SLEEVE VALVE

SPECIFY:

1. Casing Size and Weight
2. Tubing Size, Weight, Grade, and Thread
3. Service (Std, H₂S, CO₂, Amines)
4. Setting Depth of Valve
5. Cable Size for Electric Submersible Pump
6. Temperature and Pressure Requirements

Part Number Prefix: Vent Sleeve—778AVS