

Exceptional service in the national interest

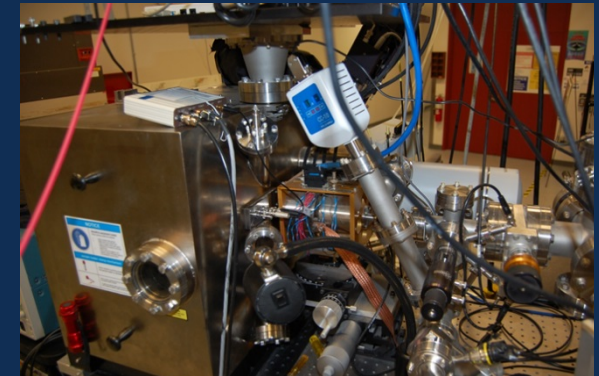
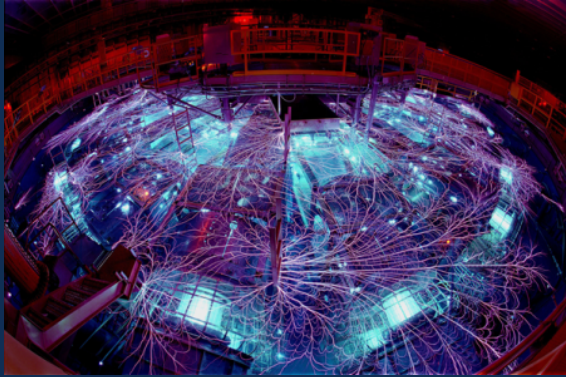

Recent Progress and Plans for MagLIF

Kyle Peterson

**Radiation Effects and High Energy Density Sciences
Research Foundation External Review, May 16-18, 2017**

We have an aggressive set of programmatic goals to evaluate the science of MagLIF and establish credible requirements for ignition and high yield.

- 
- FY17**
- Develop a methodology for inferring $B\text{-}r$ and $P\text{-}\tau$ as quantitative performance metrics from integrated MagLIF experiments.
 - Demonstrate >1 kJ of laser energy coupled to the MagLIF fuel
 - Develop and characterize a new MagLIF baseline at ≥ 20 T, ≥ 20 MA, and ≥ 2 kJ
 - Quantify the amount and relative origins of mix
 - Develop and characterize an enhanced MagLIF baseline at 30 T, 22-24 MA, and ≥ 6 kJ
 - Provide credible physics extrapolation to ignition
- FY20**
- Demonstrate 30 kJ heating on NIF
 - Achieve a BR > 0.5 MG-cm ($R/r_\alpha > 2$)
 - Achieve fuel pressure > 5 Gbar and $P\tau > 5$ Gbar-ns

A new laser preheating platform has been developed with significantly less LPI for MagLIF experiments on Z

Optical Blastwave Measurements

Original MagLiF Configuration

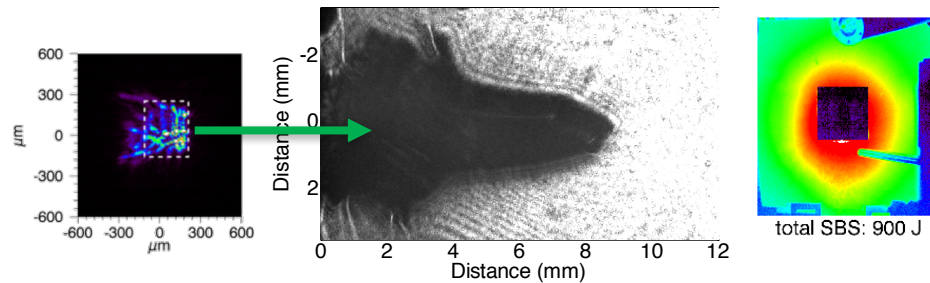

- Reduced SBS from ~50% to <3%
- Enhanced penetration depth with **reduced** laser energy
- Less conical and more cylindrical energy deposition
- ~800J deposited in gas
- *Going forward, fuel density will be increased to couple more energy to fuel*

New preheating platform – Rev 1

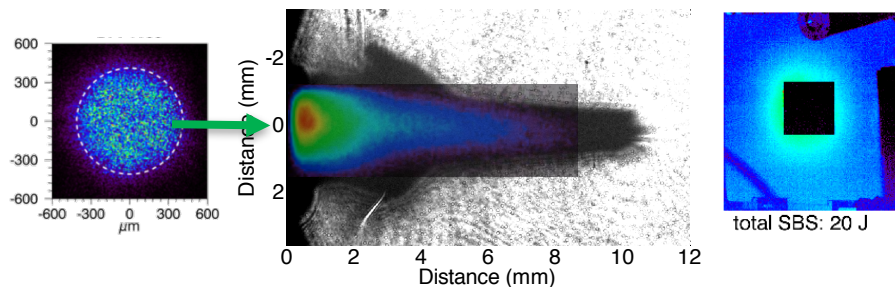

- 1100 μm Distributed Phase Plate
- Lower laser intensity
- 80 J pre-pulse, 1500J 4ns main pulse

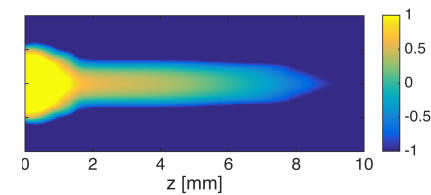

Simulated time-integrated X-ray image

The new laser preheat configuration has produced the highest MagLIF integrated yields thus far, but questions remain about reproducibility

- Neutron yield of nominally identical shots has varied by more than 10X
- Is the source of variation the laser preheat configuration or something else like liner instabilities?
 - High convergence (CR ~40)
- Repeat shots in PECOS of laser configuration show no significant shot-to-shot variations
 - Limited statistics
 - Incomplete diagnostics
 - Imperfect surrogacy

	z3040	Z3041	z3057
Laser energy	70 + 1460 J	73 + 1534 J	103 + 1283 J
Y_{DD}	$4.1e12 \pm 20\%$	$3.2e11 \pm 20\%$	$2.0e12 \pm 20\%$
Comments	~50% of clean 2D	Direct repeat of z3040.	Co coating on LEH

Variation in emission morphology with identical targets

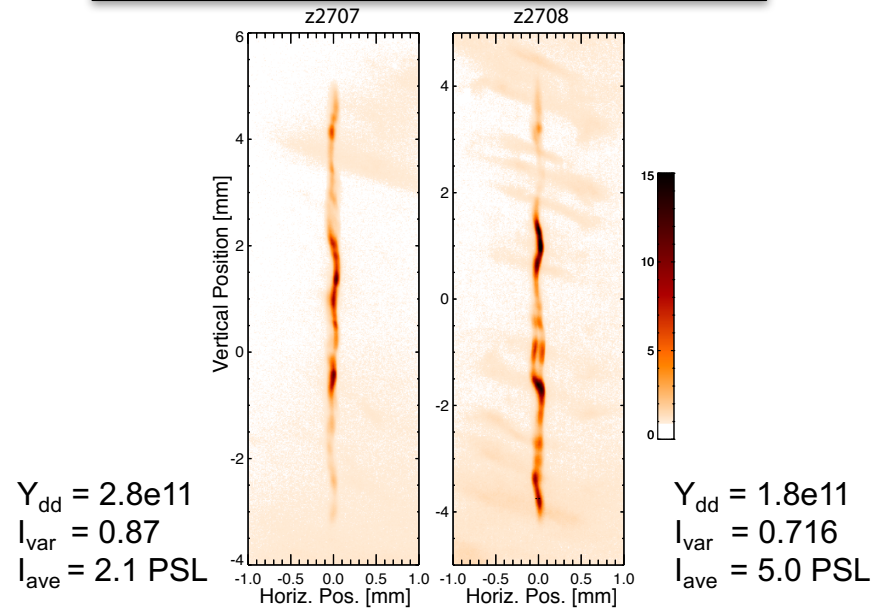

We have made significant progress in diagnosing and understanding mix in MagLIF implosions

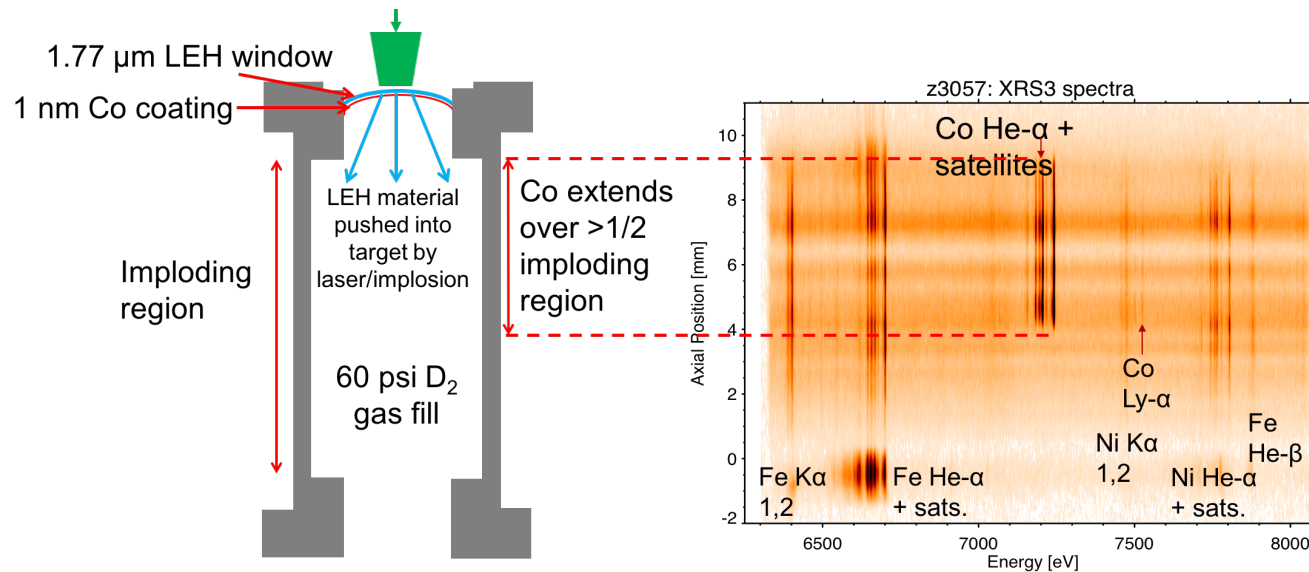

- Both window and upper endcap material has been observed to mix into fuel at stagnation
- The amount of mixed mass is still unclear as well as the relative impact of liner vs laser induced mix on stagnation performance

We have demonstrated significant improvements in liner stability in high aspect ratio liners

- Thick plastic coatings applied to outside surface mitigate electro-thermal instability growth
- Isolated engineered features are being studied to better understand surface initiation and instability seeding
 - Liner experiments at ZEBRA
 - 3D simulations/ analytic theory

>6keV X-ray self-emission stagnation images

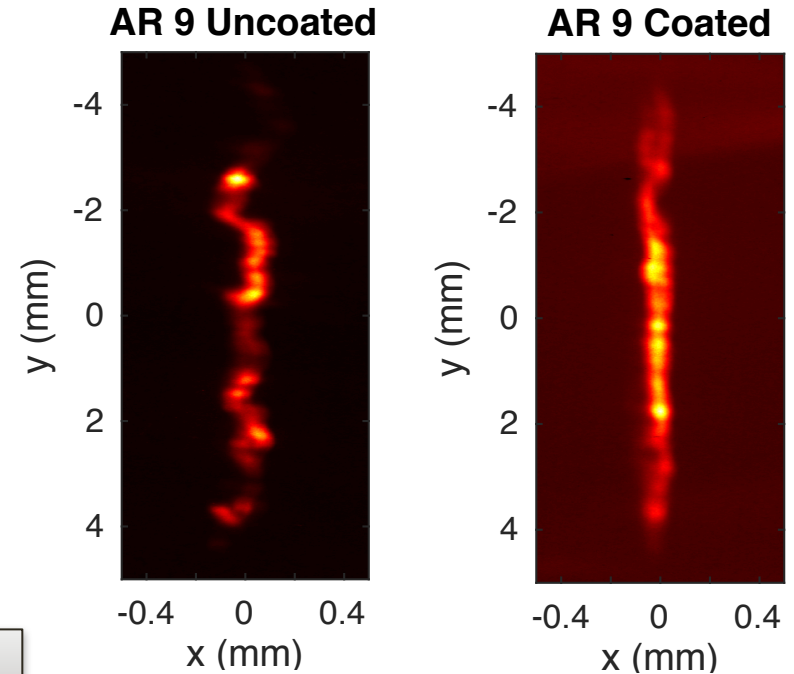

Transformation of resistive inclusions into azimuthally-correlated temperature and density perturbation

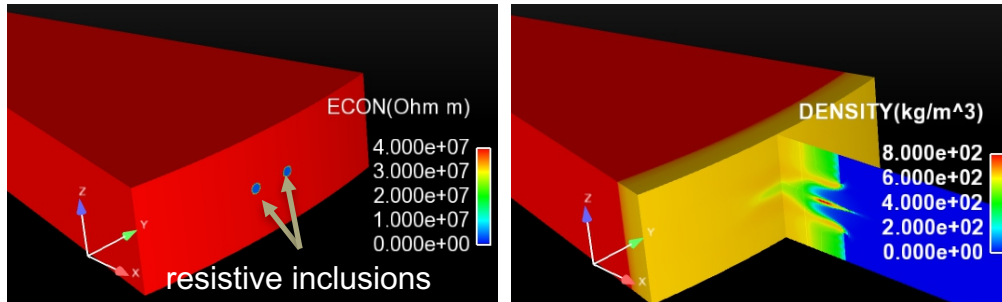

DD = 2.2e12
 DT = 1.6e10
 DD/DT = 138
 Ion ~ 2.4 keV

DD = 3.0e12
 DT = 4.8e10
 DD/DT = **63**
 Ion ~ 2.5 keV
 Mass matched
 (AR 10.6 Be, 75umEpon)

Our program plan is to develop platforms that enable testing of optimal configurations for scaling

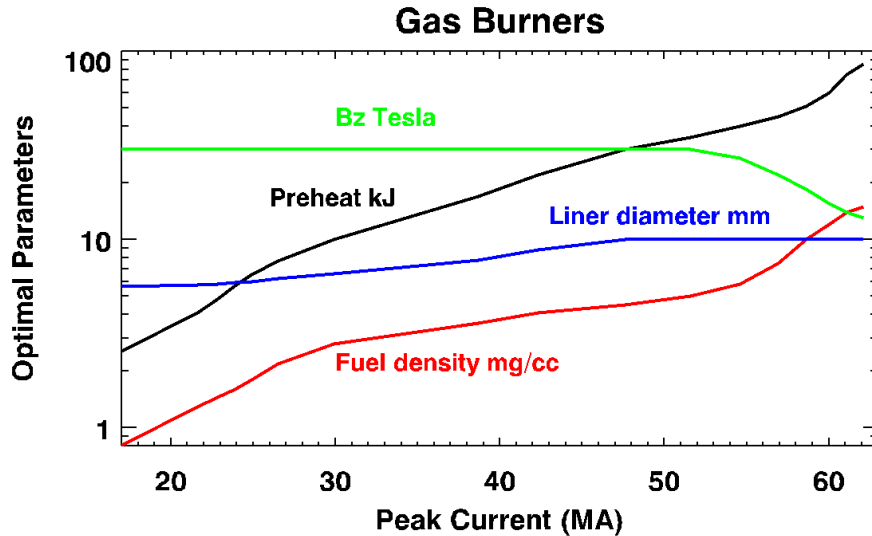

Our present experimental configuration is far from optimal

B-field=10 Tesla (optimum >30 Tesla)

Fuel density=0.7 => **high convergence**

Preheat energy < 1 kJ

Feed inductance 7.2 nH => $I_{\max} \sim 17.4 \text{ MA}$

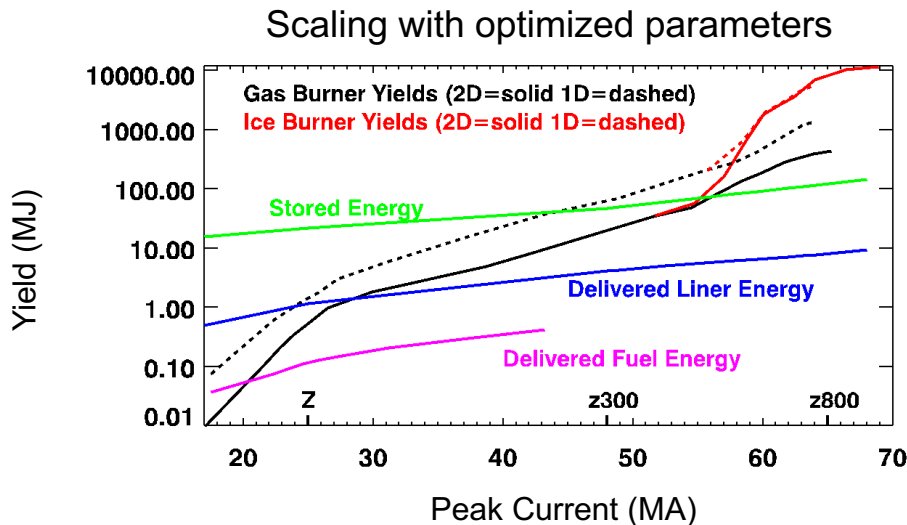

Simulations predict favorable scaling of yield with drive current¹ when MagLIF parameters are optimized

¹ S.A. Slutz et al. Phys. Plasmas 23, 022702 (2016)

Initial magnetization levels need to be increased to realize any significant increase in performance from where we are today

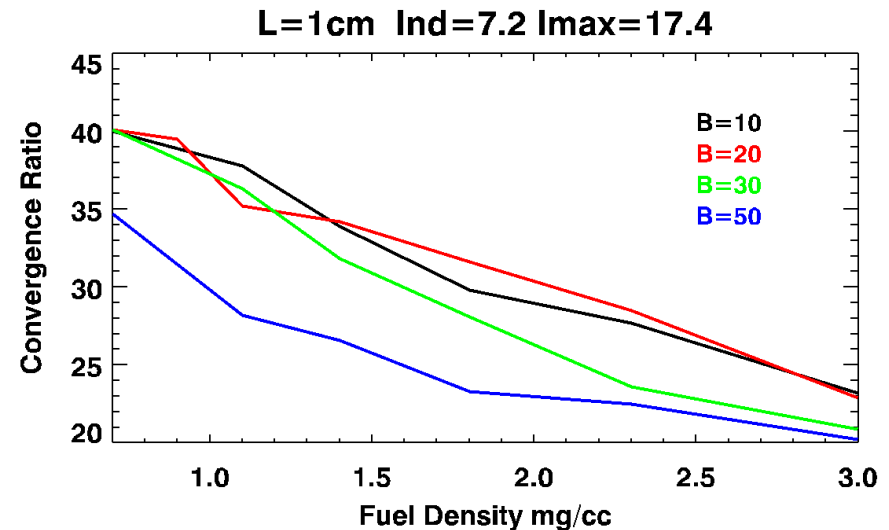
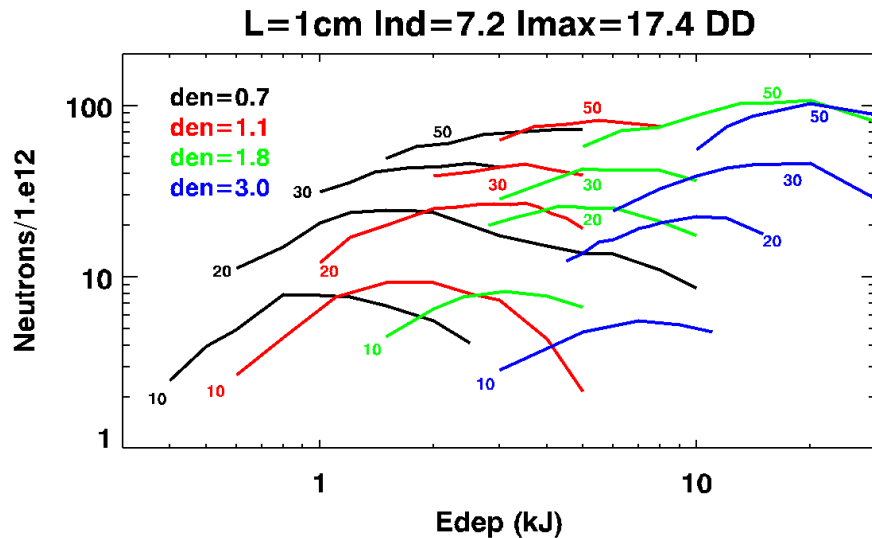

- Larger fields increase the burn time
- Higher fuel densities lower convergence
- Lower inductance feed increases current

Simulations predict the yield can be significantly increased even without increasing the current

New integrated platforms have been developed and are now being tested in order to produce conditions required for scaling

- 10-20% increase in peak current has been demonstrated with 10 T
- Capable of 20 MA, 15-20T fields (non-uniform)

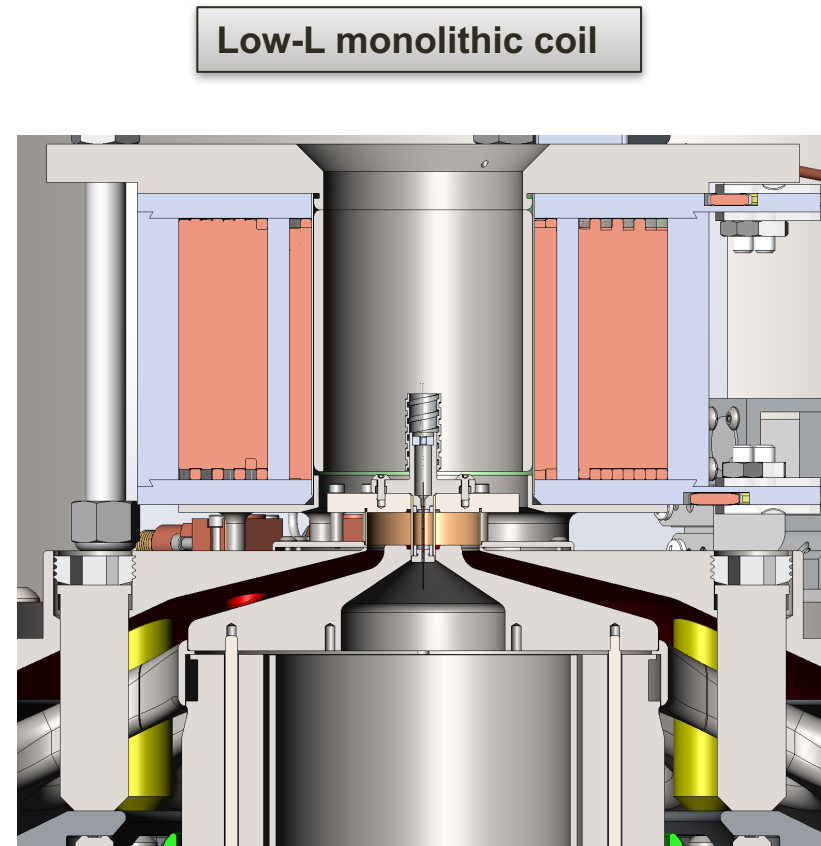
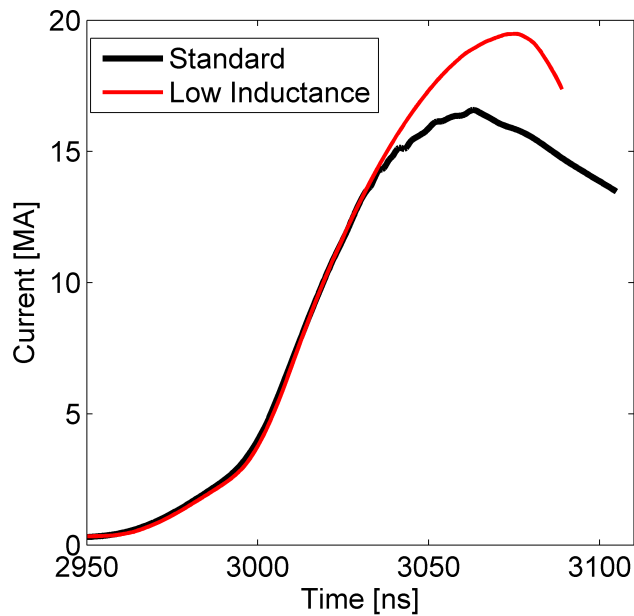

More capable platforms are also being designed, but it is a challenge to balance diagnostic access, inductance, and field uniformity

Ultra Low-L Platform

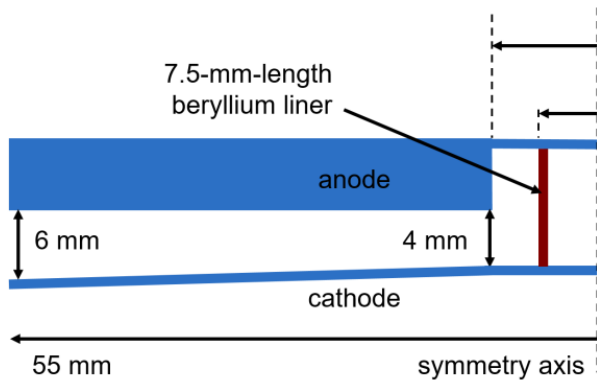

Design Goals

- ~3 nH Load Inductance
- >24 MA Peak Current
- >0.65 MJ Energy Delivered
- Up to 30 T B_z
- Limited diagnostic access

Slotted helical liners “Automag”

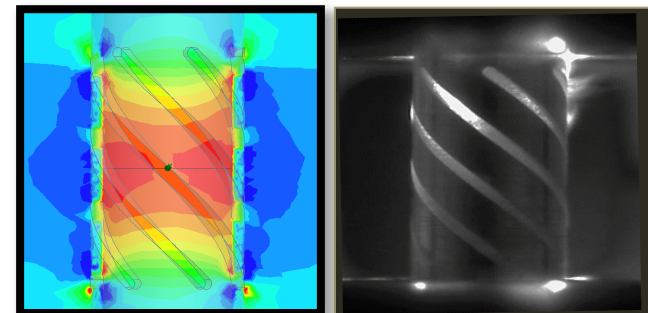
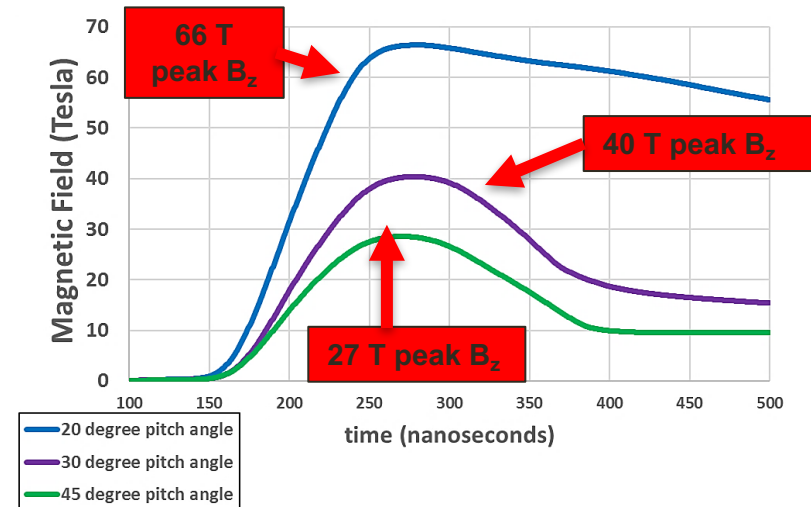

We are working to minimize the window mass which is expected to improve performance and predictability

Lasergate

- Window designed to fold open in controllable manner
- Rarefaction wave propagates downward at $\sim 1 \text{ mm}/\mu\text{s}$, voiding the tunnel region.
- Effort is just starting up

Cryo

- Ice-mitigation features including protective shroud isolating target
- New 6x faster cryostat
- New compact cryogenic deuterium fiber extruder

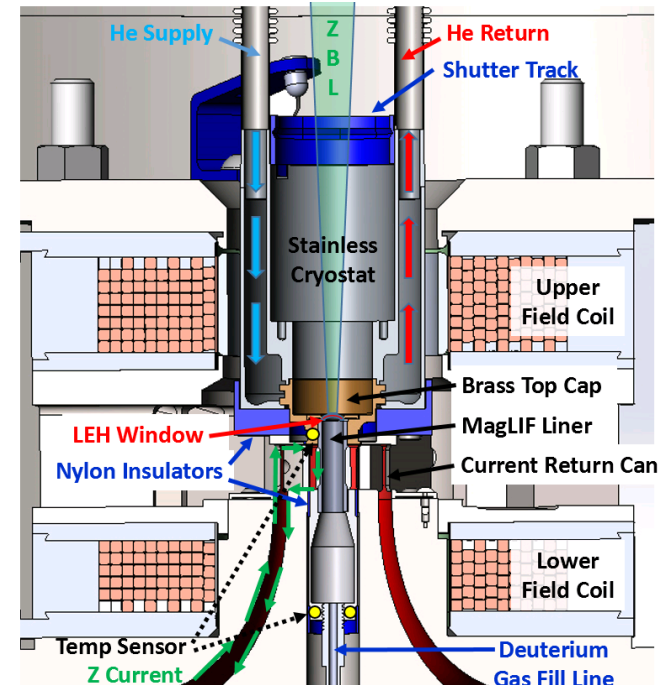
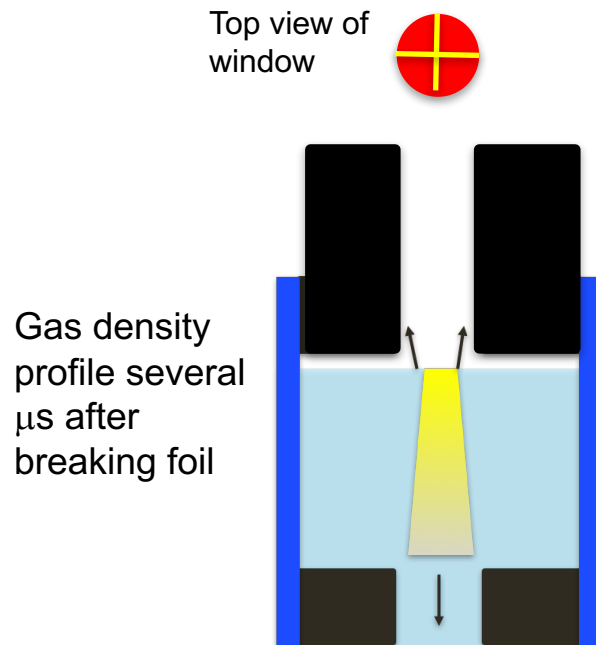

Initial laser experiments at NIF have been favorable for scaled laser heating

Pipe witness and calibration plates

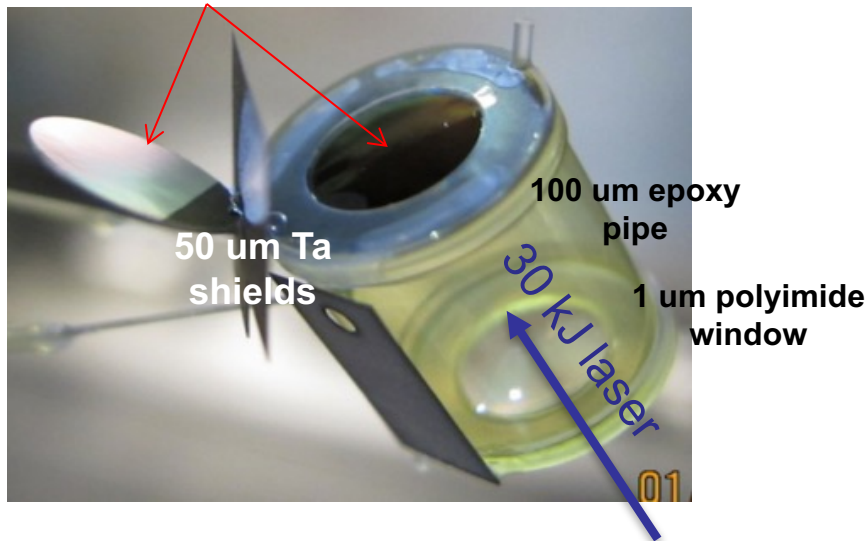

SBS time history

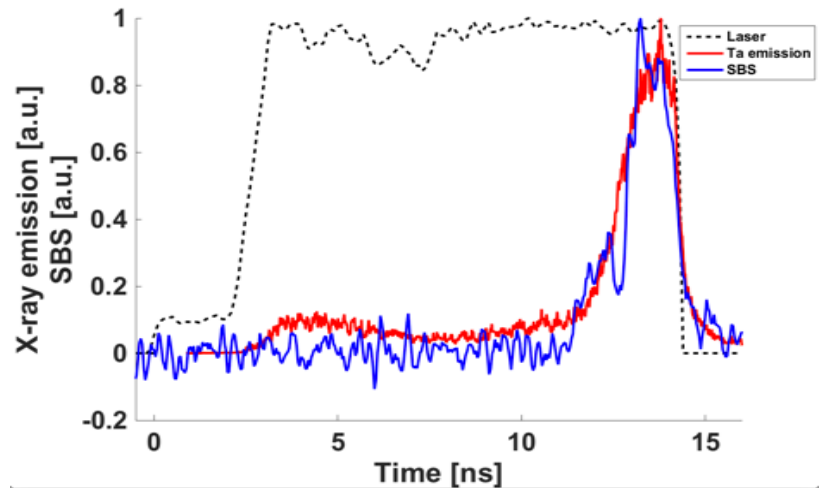

Energy coupling is >98% with minimal backscatter during propagation within the gas-pipe!

Primary Objective: Assess whether or not laser preheating is a viable scaling path for magnetized target fusion (MagLIF)

Initial laser experiments at NIF have been favorable for scaled laser heating

Pipe witness and calibration plates

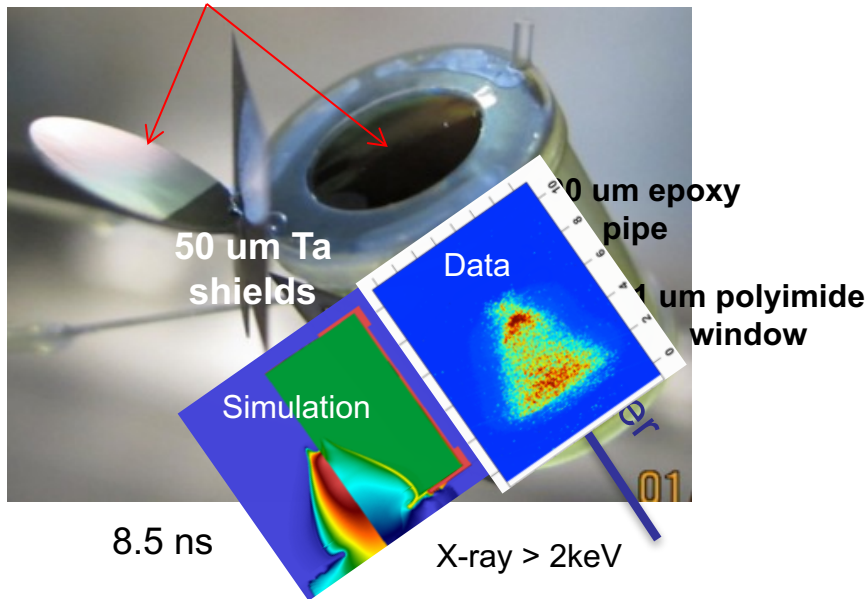

SBS time history

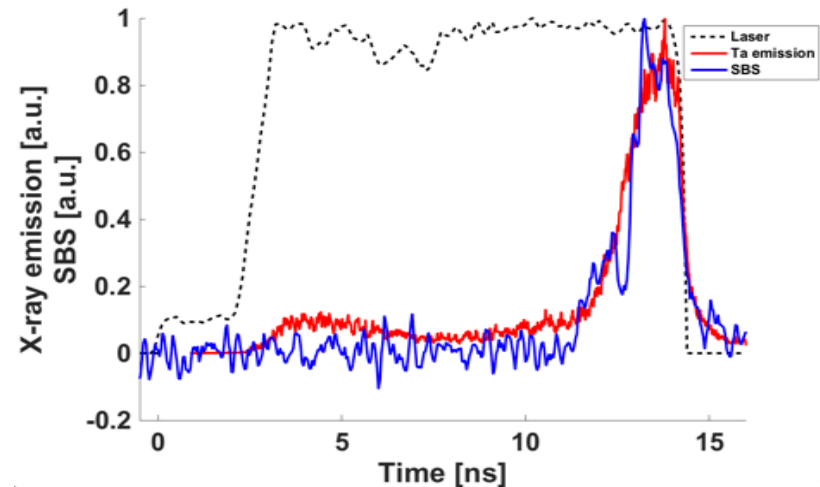

Energy coupling is >98% with minimal backscatter during propagation within the gas-pipe!

Time dependent laser propagation is in remarkable agreement with pre-shot simulation predictions

Primary Objective: Assess whether or not laser preheating is a viable scaling path for magnetized target fusion (MagLIF)

We have made significant progress in the last year, but significant challenges remain

■ Progress

- We have developed a new, significantly better understood, low LPI laser preheating platform that has produced record MagLIF performance (~50% of clean)
- We have improved our understanding of mix sources and their impact on performance
- Significant improvements in liner stability have been demonstrated with higher aspect ratio liners
- Developed new low inductance platform capable of higher currents and initial magnetization levels
- Demonstrated predictable unmagnetized laser coupling in a surrogate gas at 30kJ

■ Going Forward

- Determine source of variability in integrated experiments
- Better quantify mix and relative impact of both laser and liner mix on performance
- Evaluate MagLIF scaling with higher coupled preheat energy and higher initial fields
- More attention on efforts to minimize or eliminate the laser entrance window
- Assess whether laser heating is a viable scaling path (NIF)

Backups

Preconditioning Strategic Plan

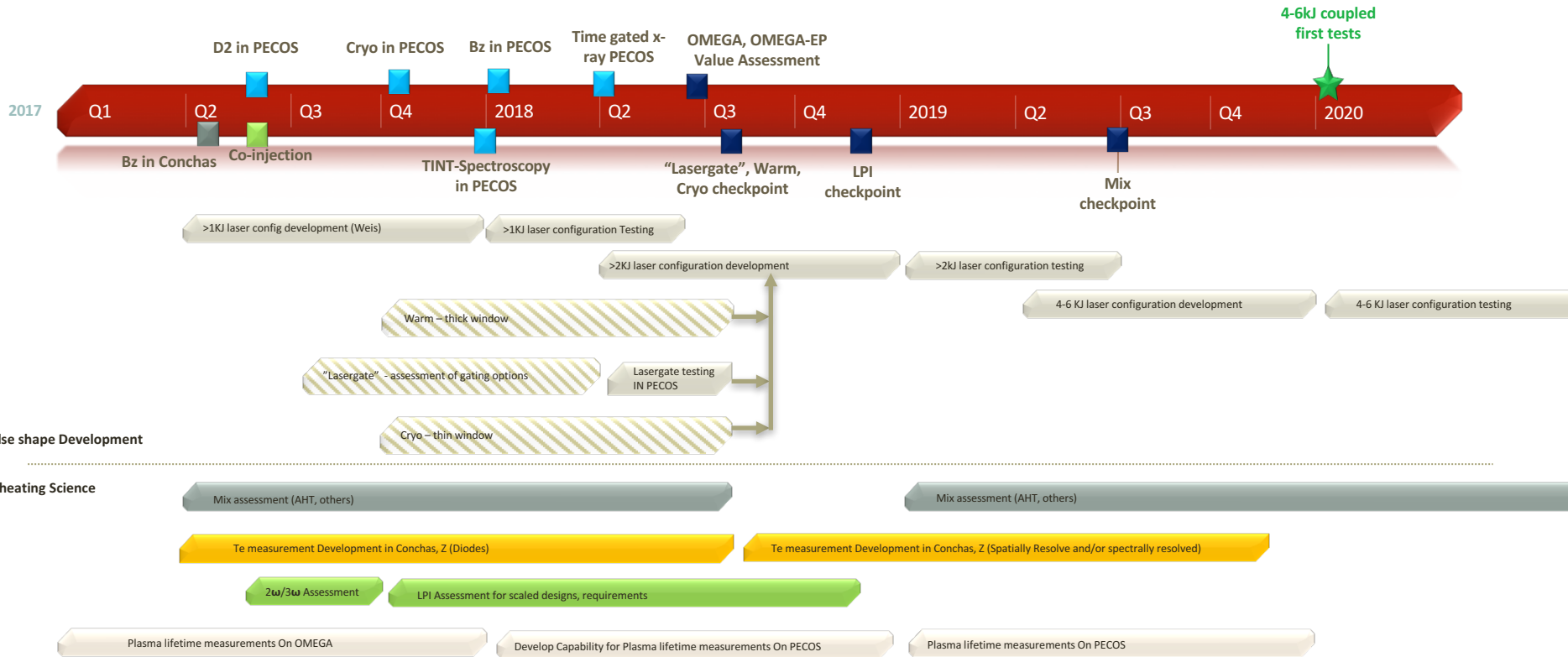

Experimental plan for NIF

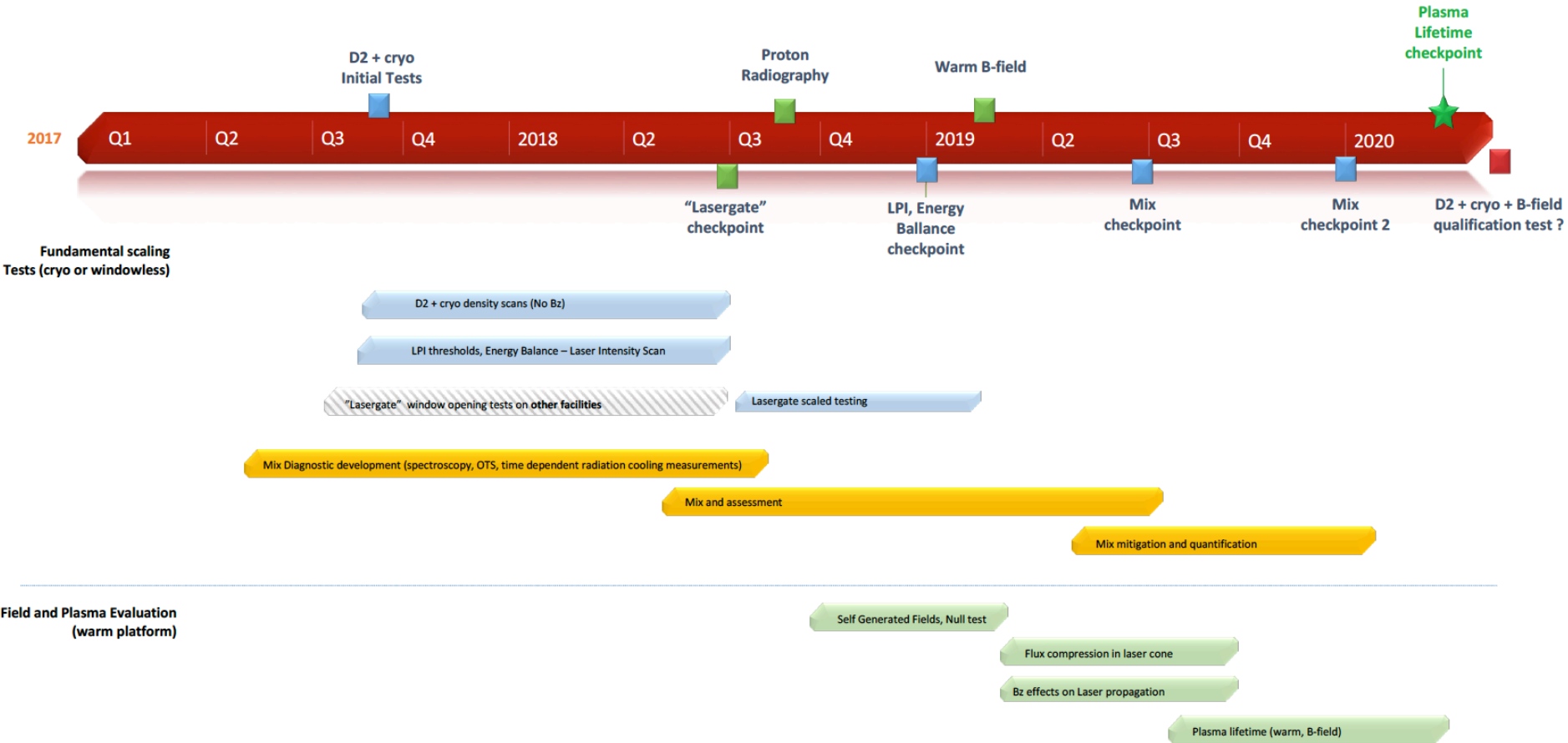

Bayesian inference tools are now being applied to better quantify stagnation performance ($P\tau$, BR) and identify important correlations

Hotspot Parameters

$$\{T_i\} = \{T_e\}$$

$$\{\tau_\nu^\ell\}$$

$$\{P_{HS}\}$$

$$\{f_{mix}\}$$

$$\{Z_{mix}\}$$

$$\{R_{HS}\}$$

$$\overline{BR}$$

$$\tau_{burn}$$

$$\delta h$$

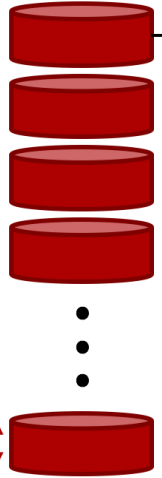

X-ray Emission:

$$Y_\nu = A_{f-f} \sum_{n=1}^N e^{-\tau_\nu^\ell} \tau_{burn} 2VP_{HS}^2 \int_0^1 \tilde{r} d\tilde{r} \frac{g_{FF}(Z)}{(1 + \langle Z \rangle)^2} \sum_i f_i \tilde{j}_i \frac{e^{-h\nu/T}}{T^{5/2}}$$

$$\tilde{j}_i \equiv \frac{j_i}{j_D} = Z_i^2 + \frac{A_{f-b} Z_i^A}{A_{f-f} T} e^{Ry Z_i^2/T}$$

Neutron Emission:

$$\frac{dN_{DD}}{dE} = \sum_{n=1}^N \frac{P_{HS}^2 V \tau_{burn}}{(1 + \sum_i f_i Z_i)^2} \int_0^1 \tilde{r} d\tilde{r} \frac{\langle \sigma v \rangle_{DD}}{T_i^2} I_o(E)$$

$$*I_o(E) = e^{-\frac{2E}{\sigma^2}(\sqrt{E}-\sqrt{E})^2}$$

$$Y_{DD} = 3.2 \times 10^{12} \pm 20\%$$

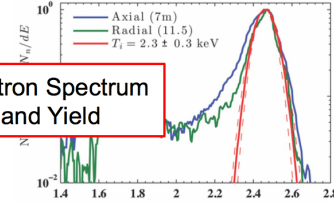

Neutron Spectrum and Yield

Ar Imager: Stagnation

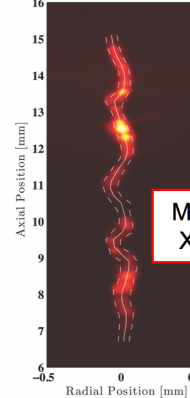

Monochromatic X-ray Imaging

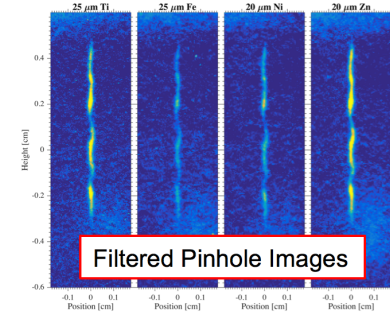

Filtered Pinhole Images

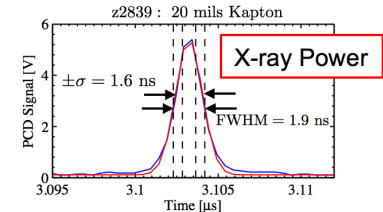

$$Y_\gamma = 10 \text{ J} \pm 20\%$$

Prior

Data

Posterior

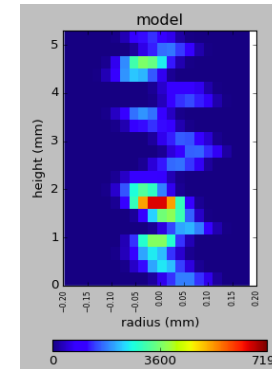
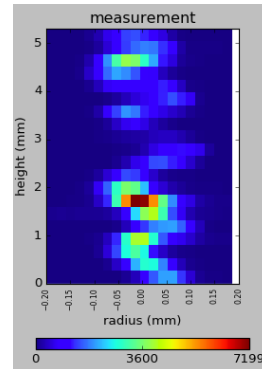
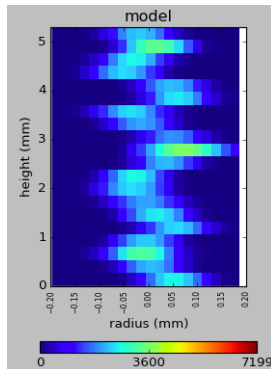

Spherical Crystal Imager Example

Minimizing Scatter Losses in MagLIF Pre-Heat

- Motivation:** Large-angle forward scatter and Brillouin backscatter reduce the coupling efficiency in pre-heat and can cause mix by heating cold, high-Z boundaries.
- Approach:** Measure both forward and backscatter at the PECOS target area and optimize by spatial and temporal laser pulse shaping.
- Outcome:** By implementing distributed phase plates, stretching the laser pulse temporally, and optimizing the pre-pulse a reduction of a factor 1000 in stimulated Brillouin Scatter was observed.

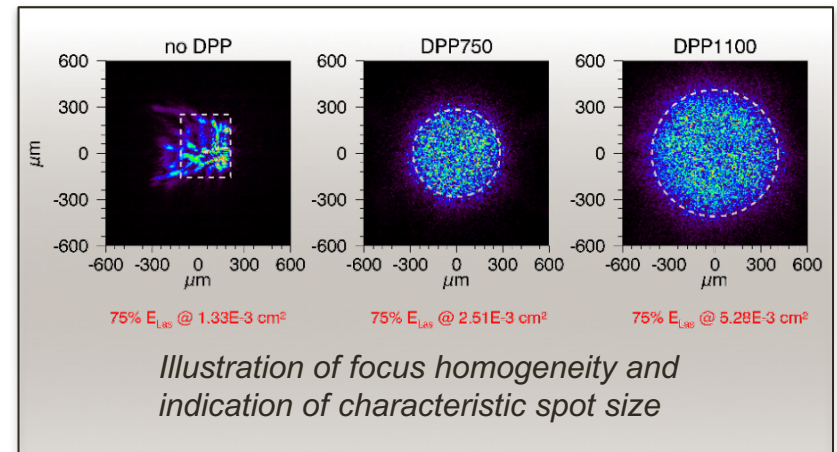

Stimul. Brillouin Scatter vs. focus type and main pulse length

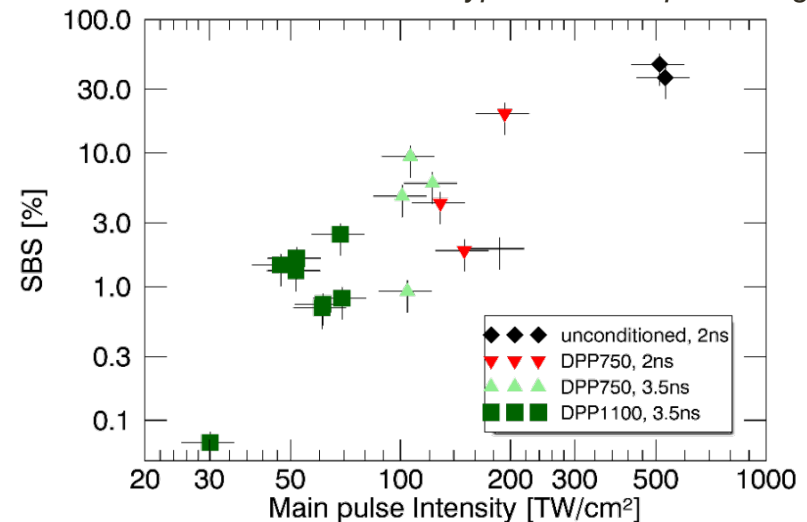

PECOS Pre-Heat Progress Summary

- Brillouin Backscatter:**
 Essentially eliminated.
- Laser heating:**
 Heated region optimized from highly conical to near-cylindrical.
 -> *Less mix potential.*
- Efficiency:**
 Laser penetration depth increased or maintained with REDUCED energy investment.
 -> *Less mix potential.*
- Impact in Z:**
 Closer to simulation and new YIELD RECORD.

Previous Pre-Heat Platform

New Pre-Heat Platform

	"Full Intensity" (poorly defined)	"Full Intensity"	"Half-Intensity"	"Quarter-Intensity"	"1/8-Intensity"
Av. focal intensity:		190 TW/cm ²	100 TW/cm ²	50 TW/cm ²	35 TW/cm ²
Pre-pulse:	310 J	230 J	220 J	240 J	60 J
Main pulse:	1800 J	1300 J	1200 J	1300 J	850 J
Phase plate:	no DPP	750 μm DPP	750 μm DPP	1100 μm DPP	1100 μm DPP

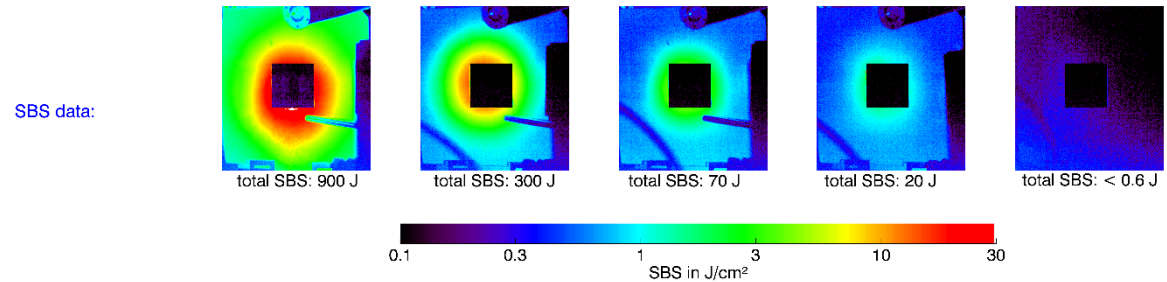
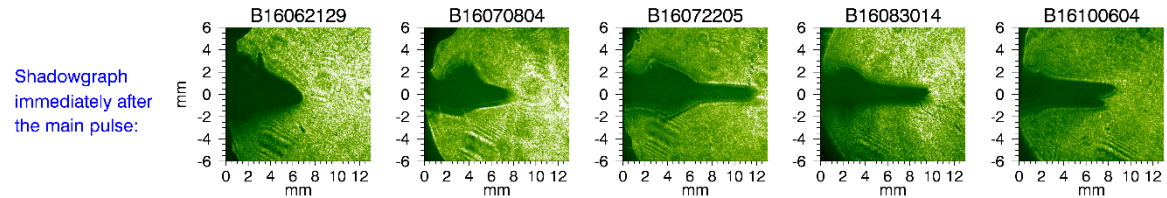

First ever tritium experiment was conducted on Z in August 2016

- **Motivation:** We need to develop experience with tritium and it can benefit our scientific understanding through higher yields (50 -100x) and higher energy spectrum neutrons (14 MeV)
- **Approach:** We safely conducted a tritium experiment on Z using a trace amount of tritium (0.1% T), applied engineering controls (e.g. containment) and thorough planning
- **Outcome:** Neutron diagnostics measured a primary DT neutron signal for the first time on Z and tritium was not detected above background levels using surface and airborne monitoring techniques

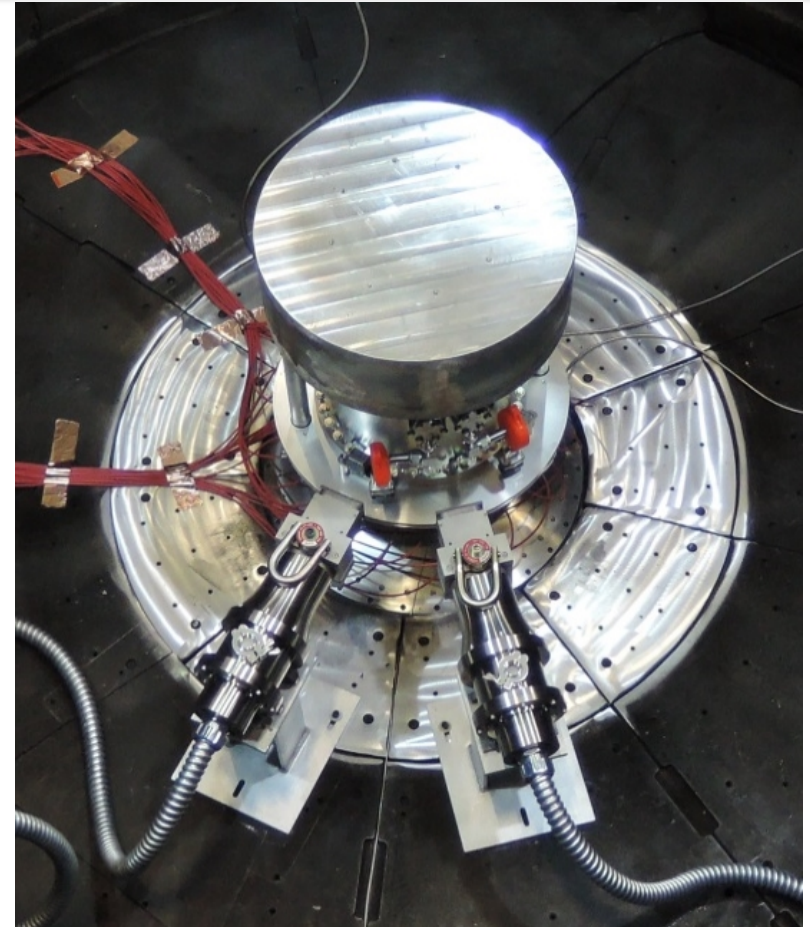

Experimental configuration for first ever tritium experiment on Z

Implosion/Stagnation and Preconditioning PRDs: Auto-magnetizing MagLIF liners (AutoMag) have demonstrated 66 Tesla axial premagnetization fields in proof of concept experiments

- **Motivation:** Can we magnetize fusion fuel to greater than 30 T while eliminating the need for external field coils?
- **Approach:** AutoMag liners were driven to >500 kA in 100 ns on the MYKONOS LTD. On-axis Bdot probes measured the axial field generated inside the liner. Fast photodiodes and gated imaging captured breakdown phenomena.
- **Outcome:** B_z greater than 65 T was recorded by magnetic field probes, consistent with pre-shot simulations. 15+ experiments have been executed; in all experiments, helical current flow has been supported with no observable surface arcing/shorting through peak current.

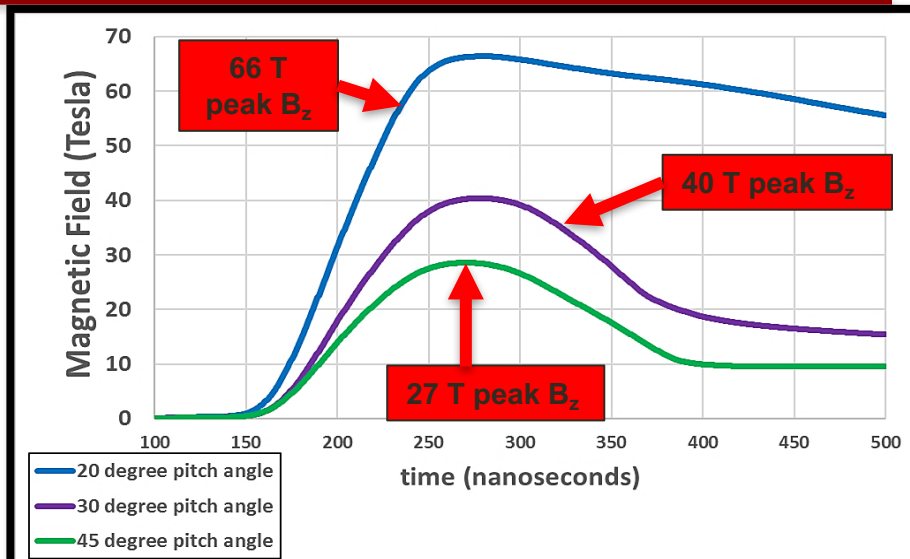

On-axis field measured inside AutoMag liners



AutoMag liners designed to generate on-axis
27 T (left)
38 T (center)
65 T (right)

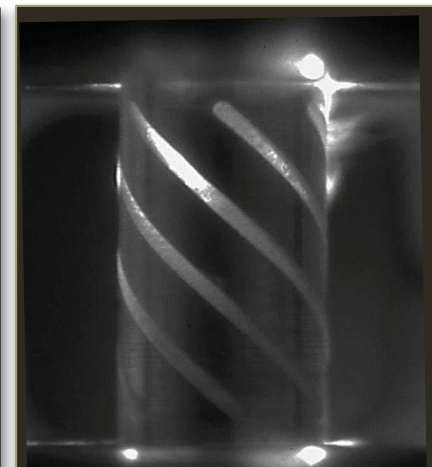
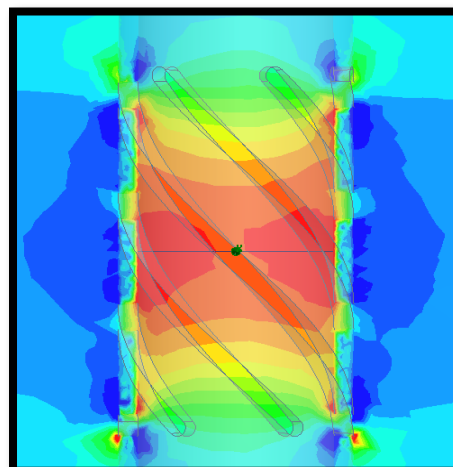

Simulation of internal B_z (left), iCCD image (right)

A compact cryogenic deuterium fiber extruder has been developed for ICF experiments on Z

- Motivation:** Select ICF target concepts include designs which require deuterium ice fibers and rods.
- Approach:** Develop an extruder which can rapidly generate deuterium ice fibers and rods. The extruder must be directly mated to an ICF target, and should be sufficiently compact and low cost to be expendable on Z experiments.
- Outcome:** A cubic-inch-scale deuterium extruder has been developed. The system is designed with interchangeable nozzles to offer a range of fiber dimensions. The extruder is currently being tested in offline experiments to determine whether it can reliably generate deuterium fibers to fuel Z ICF targets.

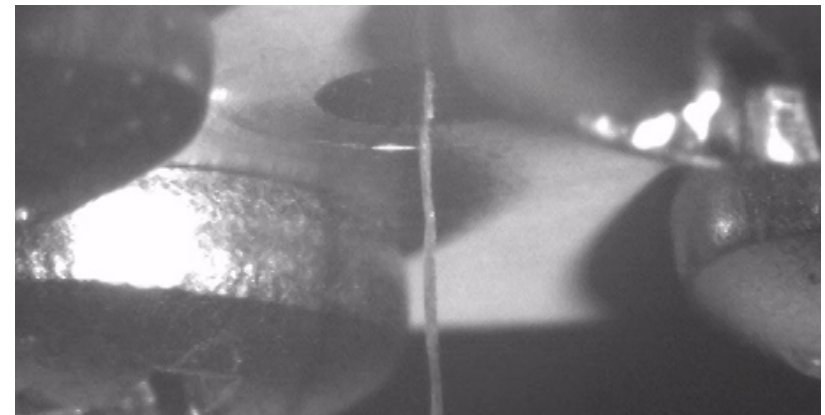
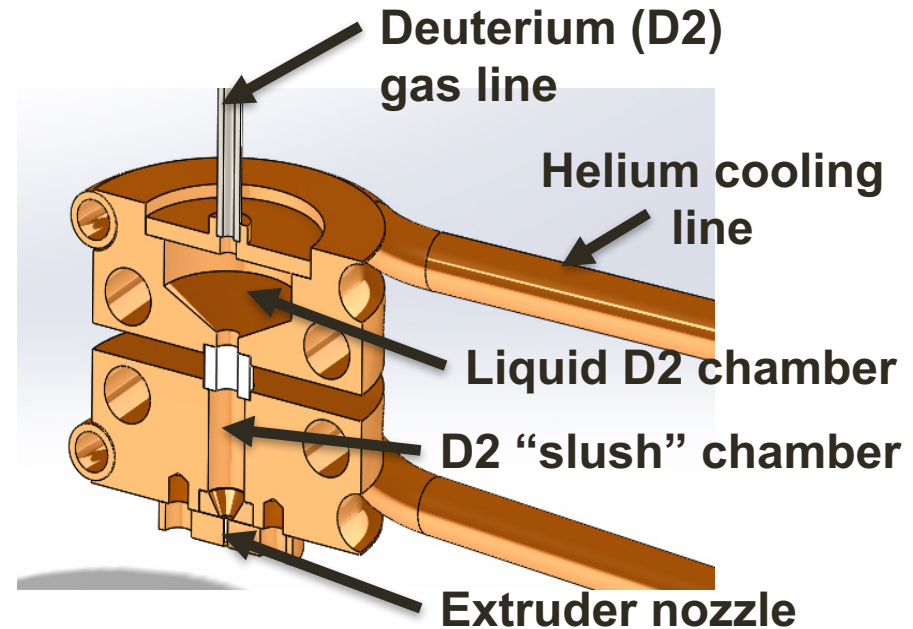

Extruder Design (Top) and D2 Fiber (bottom)

Transformation of resistive inclusions into azimuthally-correlated temperature and density perturbation

- **Motivation:** Can small ($\sim 5 \mu\text{m}$) resistive inclusions embedded in Al rods/liners be responsible for azimuthally broad ($\sim 100 \mu\text{m}$) emission features (i.e. striations) seen in Ohmically heated rods? Can these hot striations evolve into density perturbations, thus seeding later-time magneto-Rayleigh Taylor (MRT) instability?
- **Approach:** We used analytic theory and 3D MHD simulation of Al rods, embedded with 2 resistive inclusions (see a), to study how current redistributes around inclusions, and the ensuing evolution.
- **Outcome:** Current redistribution combined with the electrothermal instability drives a temperature perturbation connecting the 2 inclusions (see b). Later, this hot striation explodes, generating a wide density perturbation (see c), which can seed the MRT instability.

a) 3D periodic wedge simulation:
Electrical conductivity($t=0$)

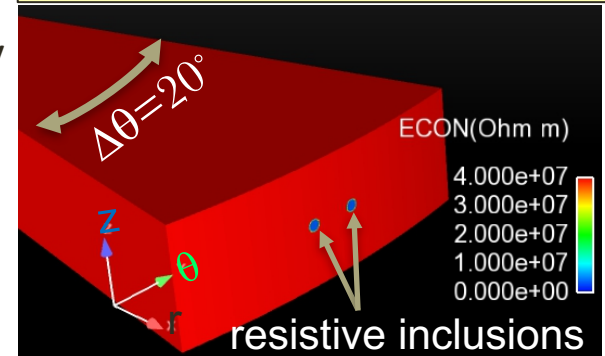

b) Temperature correlation ($t=110 \text{ ns}$)

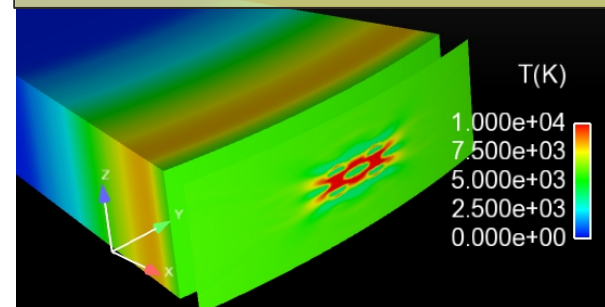

c) Density perturbation ($t=120 \text{ ns}$)

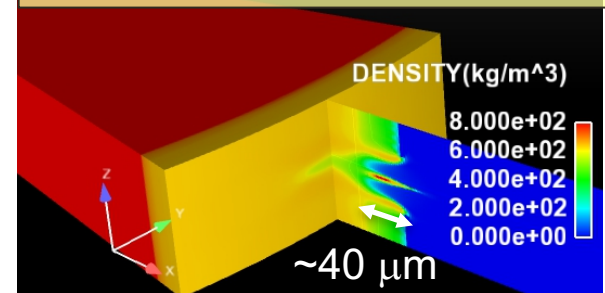

Demonstration of vortex generation and amplification in MagLIF

- **Motivation:** Most MagLIF simulations assume an azimuthally symmetric laser energy deposition, but experiment shows a filamented, non-uniform beam. What additional physics does this introduce?
- **Approach:** We used a 2D (r, θ) MHD simulation to study the implosion and stagnation of a MagLIF-like liner when energy is deposited in 2 off-centered beams (see a).
- **Outcome:** Oblique shocks generated by asymmetric energy deposition result in vortices, which are amplified during implosion, due to (approximate) conservation of angular momentum. Vortex velocities can be $\sim 4X$ liner implosion velocities (see b), and deform the liner from the inside-out, rather than from outside-in (e.g. MRT feedthrough).

a) Temperature at initial energy deposition

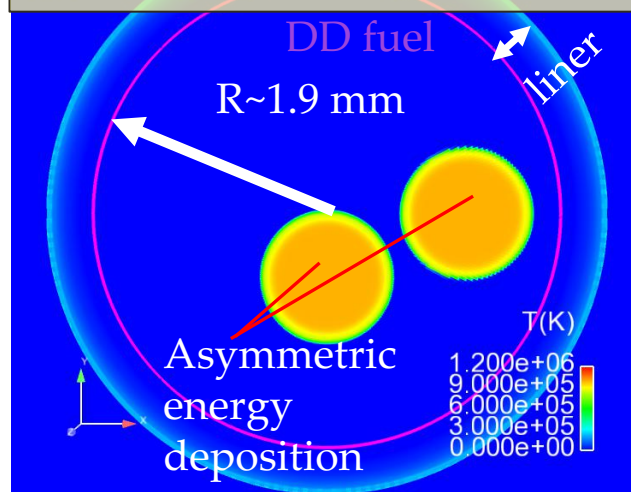

b) Velocity near stagnation

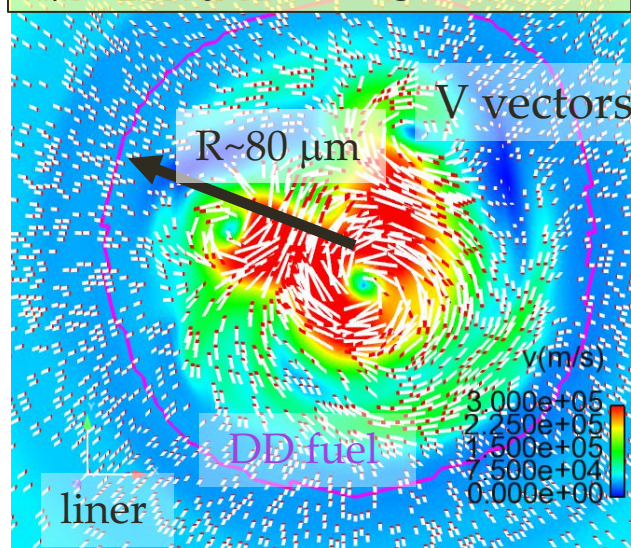

Activation of the Chama Target Chamber

- Motivation:** Activate the last of five high energy laser target chambers in order to perform combined Z-Beamlet (ZBL) and Z-Petawatt (ZPW) experiments.
- Approach:** Using an existing beam line, we steered the ZPW beam to the Chama chamber utilizing custom meter scale mirror mounts and in-house coated optics.
- Outcome:** ZPW has been focused at target chamber center. This enables a large range of novel experiments, such as prototyping of dynamic diffraction experiments on the Z-machine (ongoing LDRD).

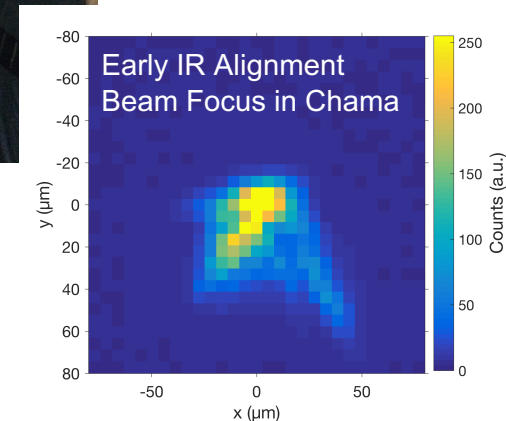

Initial Chama Chamber Alignments

Activation of Co-injection Beam

- **Motivation:** Provide a 2nd ZBL like beam for:
 - Having an arbitrarily variable temporal pre-pulse to “blow-off” the MagLIF laser entry hole,
 - Providing additional pre-heat for MagLIF, and
 - Allowing for the possibility of developing a backlighting capability for laser heated MagLIF experiments.
- **Approach:** We modified the existing Z-Petawatt short-pulse laser to operate in long pulse (ns) mode. The beam is then co-injected with a dichroic combiner and frequency doubled.
- **Outcome:** We demonstrated 200J at 527nm long pulse mode and are currently in the commissioning phase, having already shot into a ZBL target chamber.

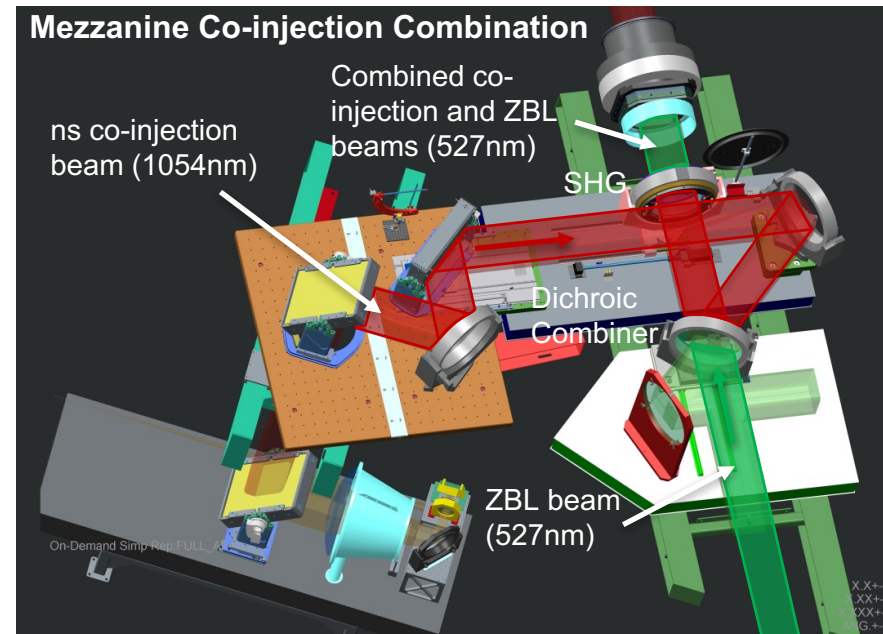

Co-Injection Efforts

Preheat PRD: OMEGA-EP experiments suggest pulse-shaping may reduce laser preheat backscatter

- **Motivation:** MagLIF experiments show large amounts of stimulated Brillouin backscatter (SBS) during laser preheat when the laser intensity is too high which reduces coupled energy and may lead to irreproducibility
- **Approach:** Experiments on the OMEGA-EP laser at the Laboratory for Laser Energetics tested the effect of temporal pulse-shaping on SBS from a gas-filled tube utilizing backscatter diagnostics developed for this campaign
- **Outcome:** Increasing the dwell time between prepulse and main pulse eliminated SBS during the main pulse suggesting that laser entrance hole disassembly plays a role in SBS growth and may be mitigated by pulse-shaping

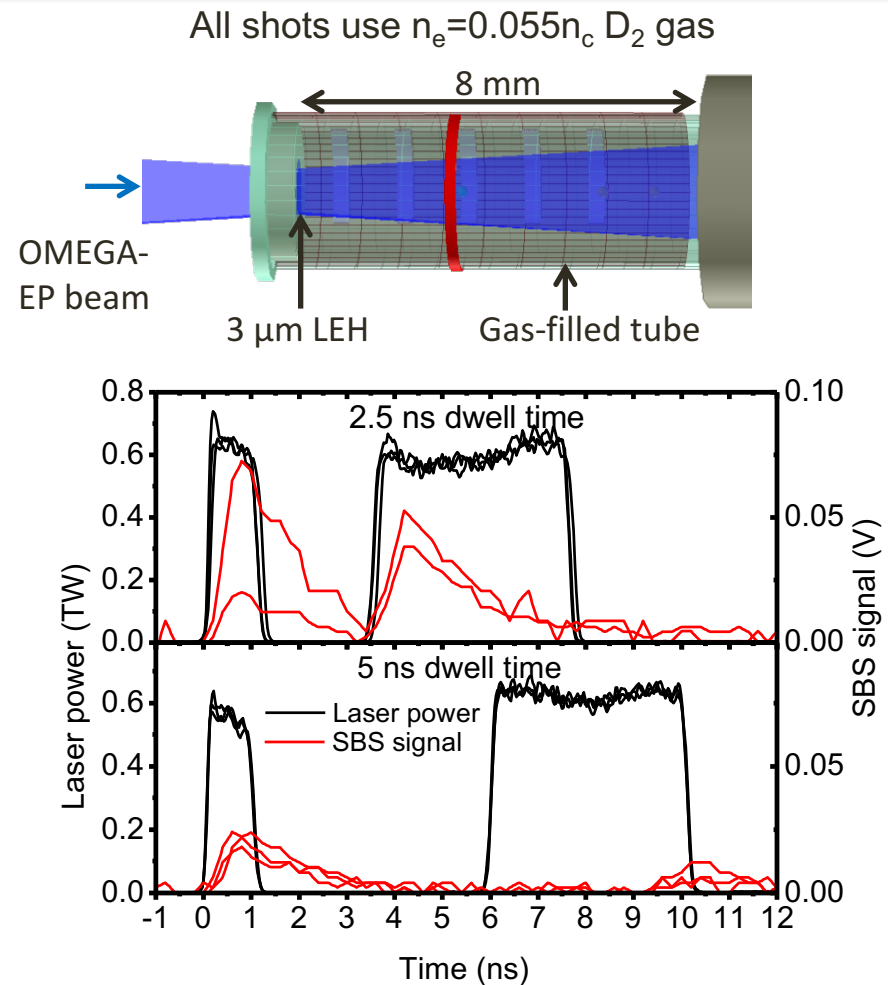

Laser power and SBS signals for two different pulse shapes

Preheat PRD: OMEGA experiments show possible benefits of high frequency, smoother beams for preheat

- **Motivation:** We want to know what changes could be made to the Z-beamlet laser to improve MagLIF preheat. Possible alterations include increased spatial smoothing and increasing the laser frequency from 2ω to 3ω if desirable
- **Approach:** Experiments on the OMEGA laser at the Laboratory for Laser Energetics compared laser heating of gas cell targets for 2ω and 3ω beams with and without smoothing by spectral dispersion (SSD) over a range of intensities
- **Outcome:** Significantly more hard x-rays (indicative of stimulated Raman scattering) are produced for 2ω vs. 3ω beams and 2D SSD smoothing reduces hard x-ray production. Results indicate possible benefits of 3ω SSD smoothed beams for MagLIF preheat.

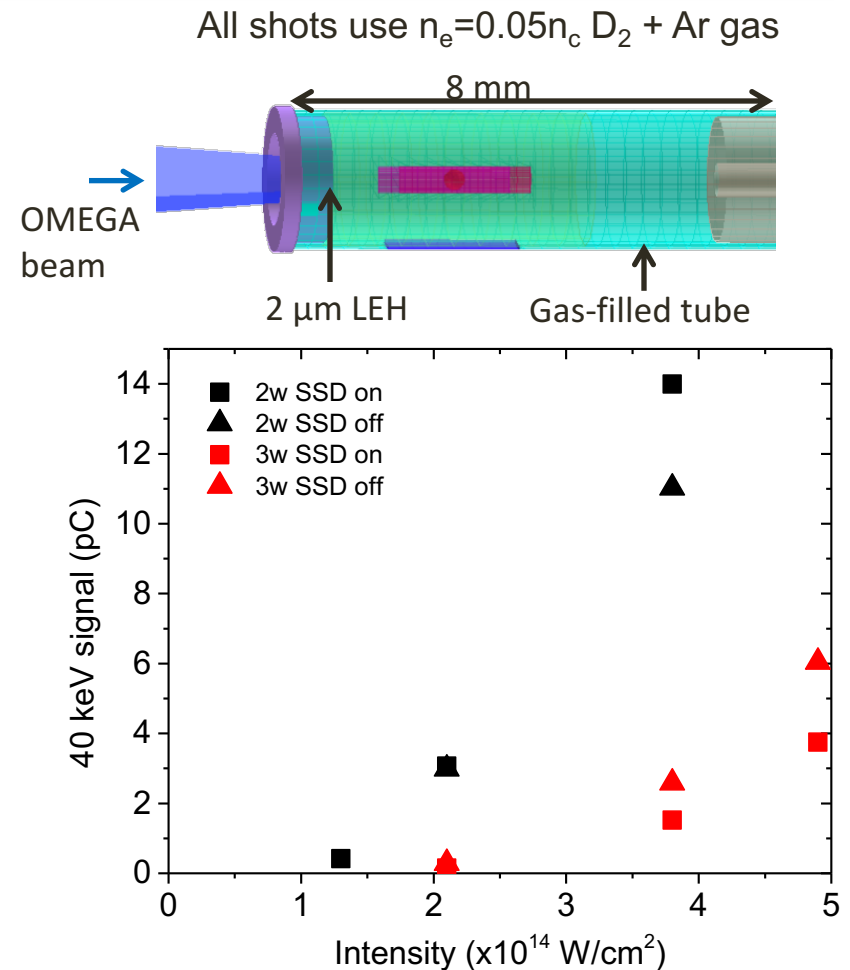

Hard x-ray signals indicative of stimulated Raman scattering

Preheat PRD: New phase-plate-smoothed preheat protocols have been successfully designed, tested on Z

- Motivation:** Previous MagLIF experiments used a laser without spatial smoothing for preheat that is known to produce significant amounts of stimulated Brillouin backscatter (SBS) and was thought to contribute to shot-to-shot variability.
- Approach:** A distributed phase plate (DPP) was used to increase spot size and spatial uniformity and reproducibility. Various pulse shapes were tested offline and a protocol developed that dramatically reduced SBS while maintaining similar deposition profiles in gas cells to the old protocol
- Outcome:** Initial results produced large neutron yields but still with significant shot-to-shot variability, the cause of which is being investigated.

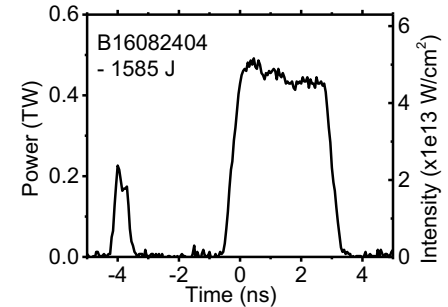
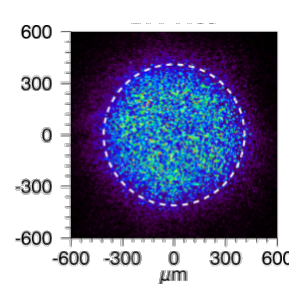

PECOS gas cell shadowgraphy
– 54 psi He

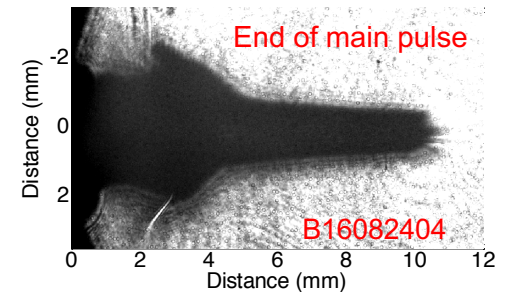

	z3040	z3041	z3057
Laser energy	70 + 1460 J	73 + 1534 J	103 + 1283 J
Y_{DD}	$4.1e12 \pm 20\%$	$3.2e11 \pm 20\%$	$2.0e12 \pm 20\%$

New preheat protocols with DPP smoothing produced high but variable yields

PECOS Deuterium Implementation

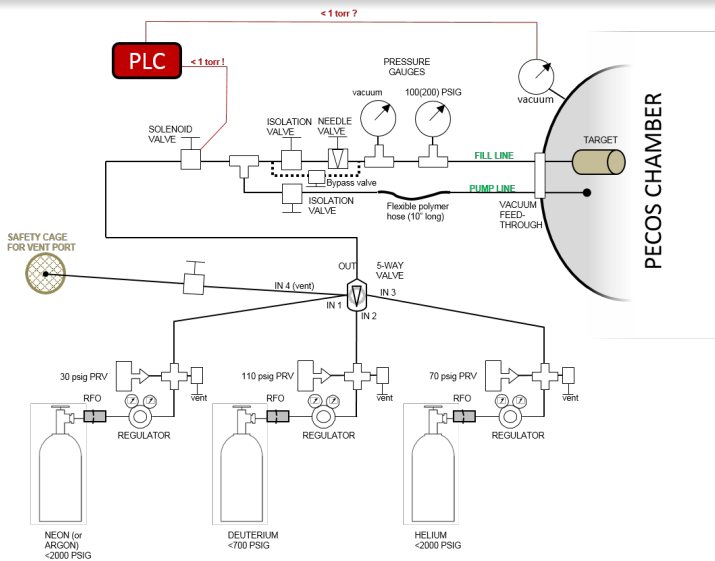

Implementation Photographs

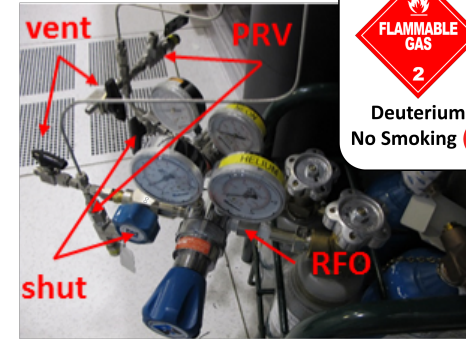
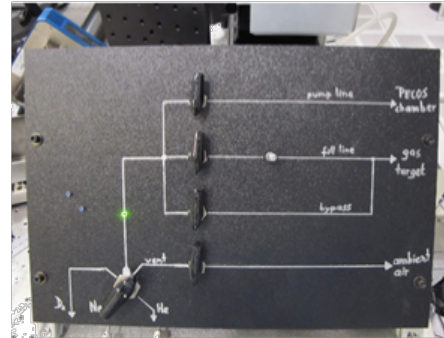

Safety Assessment Topics Finished

- ✓ multiple work-meetings and line reviews
- ✓ including 10 subject-matter-experts
- ✓ Radiological issues (neutron generation)
- ✓ fire safety (auto-ignition, LEL, electrical compatibility, fire extinguishers)
- ✓ pressure safety (hydrogen embrittlement)
- ✓ industrial hygiene (asphyxiation, failure mode analysis with process map)
- ✓ ES&H, vacuum equipment compatibility

Implementation Progress

- ✓ New D₂ compatible manifold and control panel
- ✓ Programmable Logic Controller for safety solenoid-valve (**completed**) with LabView Interface (**in progress**)
- ✓ Deuterium Safety Memo, Job Safety Analysis
- ✓ Additional (turbo-molecular) pump installed (PLC contr.)
- ✓ Safety Case Write-up (**under review**)
- ✓ D₂ regulator and custom-fill lecture bottle acquired
- ✓ Pressure Safety Data Package (**reviewed, not yet signed**)
- ✓ Safety signs (**defined/designed, on order**)

Activation of the Chama Target Chamber

- Motivation:** Activate the last of five high energy laser target chambers in order to perform combined Z-Beamlet (ZBL) and Z-Petawatt (ZPW) experiments.
- Approach:** Using an existing beam line, we steered the ZPW beam to the Chama chamber utilizing custom meter scale mirror mounts and in-house coated optics.
- Outcome:** ZPW has been focused at target chamber center. This enables a large range of novel experiments, such as prototyping of dynamic diffraction experiments on the Z-machine (ongoing LDRD).

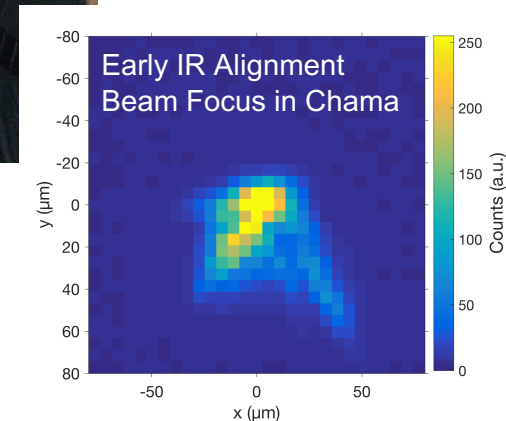

Initial Chama Chamber Alignments

Activation of Co-injection Beam

- **Motivation:** Provide a 2nd ZBL like beam for:
 - Having an arbitrarily variable temporal pre-pulse to “blow-off” the MagLIF laser entry hole,
 - Providing additional pre-heat for MagLIF, and
 - Allowing for the possibility of developing a backlighting capability for laser heated MagLIF experiments.
- **Approach:** We modified the existing Z-Petawatt short-pulse laser to operate in long pulse (ns) mode. The beam is then co-injected with a dichroic combiner and frequency doubled.
- **Outcome:** We demonstrated 200J at 527nm long pulse mode and are currently in the commissioning phase, having already shot into a ZBL target chamber.

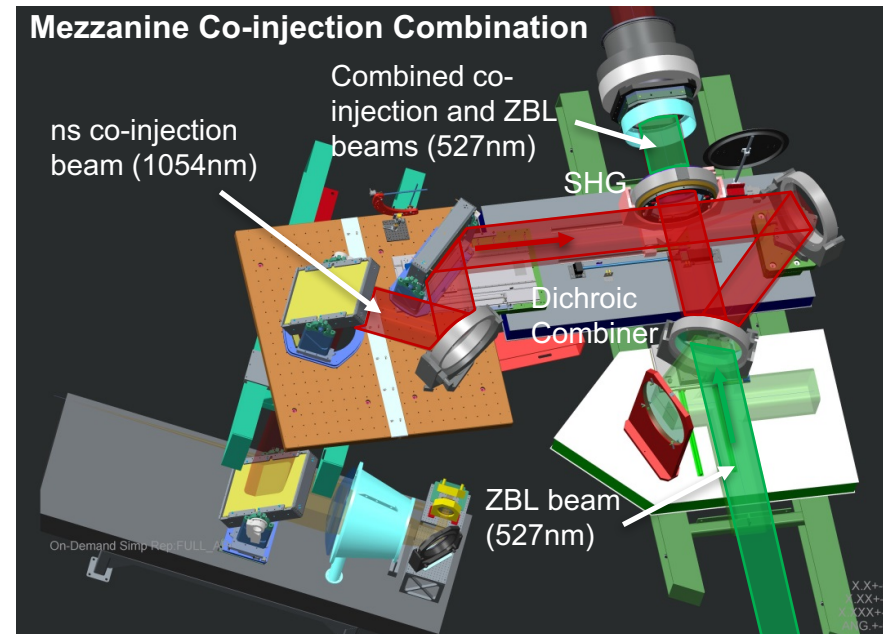

Co-Injection Efforts