



Nuclear Material Accounting & Control (NMAC) LEU Fuel Fabrication Modeling

Ben Cipiti
Nathan Shoman
Philip Gibbs



Project Goals

- **The goal of these slides is to provide guidance on the development of a process model for fuel fabrication to support Nuclear Material Accounting and Control (NMAC) for future fuel cycle facilities.**
- **The U.S. Separation and Safeguards Performance Model (SSPM) is being used as a basis.**
- **Such a model can help with nuclear materials accountability, process monitoring, and provide the ability to optimally design these systems for the facility at an early stage.**



Definitions



Terms and Definitions

Nuclear Security

The prevention of, detection of, and response to criminal or intentional unauthorized acts involving or directed at nuclear material, other radioactive material, associated facilities, or associated activities.

The overall objective of a State's nuclear security regime is to protect persons, property, society, and the environment from malicious acts involving nuclear material and other radioactive materials.



Terms and Definitions

System for Nuclear Material Accountancy and Control (NMAC)

An integrated set of measures designed to provide information on, control of, and assurance of the presence of nuclear material, including those systems necessary to establish and track nuclear material inventories, control access to and detect loss or diversion of nuclear material, and ensure the integrity of those systems and measures.



Terms and Definitions

Material balance area (MBA)

is an area in or outside of a facility such that:

- The quantity of nuclear material in each transfer into or out of each 'material balance area' can be determined
- The physical inventory of nuclear material in each 'material balance area' can be determined when necessary, in accordance with specified procedures, in order that the material balance for Agency safeguards purposes can be established" (IAEA INFCIRC 153)

IAEA INFCIRC/153; Use of Nuclear Material Accounting and Control for Nuclear Security Purposes at Facilities, IAEA Nuclear Security Series 25G;



Terms and Definitions

Traditional Physical Inventories

Traditional physical inventories are inventories taken at a defined frequency, based on regulation or IAEA agreement, where the process is emptied (to the extent possible), material containerized and measured, and any residual in process materials and/or residual hold-up materials measured.



Terms and Definitions

Material Unaccounted For (MUF)

Material Unaccounted For (MUF) refers to the difference between the book inventory and the physical inventory for a Material Balance Area over a material balance period. It is calculated as:

$$MUF = (BI+R-S)-PE$$

- *BI is the beginning physical inventory*
- *R is the sum of receipts or increases to inventory*
- *S is the sum of shipments or decreases to inventory*
- *PE is the ending physical inventory*

Book
Inventory

Note: MUF is called inventory difference or ID in the U.S. Department of Energy



Terms and Definitions

Sigma MUF

Sigma MUF is a statistical measure of variability or standard deviation that takes into account measurement uncertainties and nature of processing to determine an overall uncertainty around the material balance.

If the process is operating normally, it is expected that the MUF will be within the limits of Sigma MUF. If the MUF exceeds the limits of Sigma MUF, it is considered not normal and cause for investigation.



Terms and Definitions

Near Real Time Accountancy (NRTA)

A form of nuclear material accountancy for bulk handling material balance areas in which itemized inventory and inventory change data are maintained by the facility operator and made available to the IAEA on a near real time basis so that inventory verification can be carried out and material balances can be closed more frequently than, for example, at the time of an annual physical inventory taking by the facility operator



Terms and Definitions

Process/Control Units

The term Process Unit or Control Unit may be used interchangeably and signify a defined process, piece of equipment or multiple pieces of equipment to which inputs and outputs are tracked and material balances can be determined. Process or control units are a sub-set of a MBA unit and are used in process monitoring to localize inventory differences and/or better detect operations outside normal expectations.



Terms and Definitions

Process Monitoring (DOE)

“Process Monitoring is a methodology to ensure that special nuclear material (SNM) is in its authorized location and when effectively implemented, it is a useful tool to detect anomalous process conditions and indicate losses of SNM well before the scheduled physical inventory.”

U.S. DOE Standard – DOE-STD-1194-2011 Change 3 – Nuclear Materials Control and Accountability, Paragraph 6.2.4.5– Oct 2013



Terms and Definitions

Process Monitoring (IAEA)

“Process Monitoring is an extended form of containment and surveillance especially supporting near-real-time materials accountancy that makes the best use of information mainly acquired by facility operators in order to detect unusual (anomalous, abnormal) conditions (activities, movements, situations) that might be indicative of diversions”.

Change this reference to the Nuclear security material control guide soon to be published NST-033.



LEU Fuel Fabrication Overview



Reference Document

The fuel fabrication NMAC model was based on the IAEA STR-150 document, “Detailed Description of an SSAC at the Facility Level for a Low-Enriched Uranium Conversion and Fuel Fabrication Facility.” This reference includes:

- An example facility flowsheet
- Material Balance Areas and Key Measurement Points
- Measurement methods and procedures
- Examples of Physical Inventory Taking
- Examples of closing the material balance



Matlab Simulink

Based on STR-150, a Matlab Simulink model of a LEU Fuel Fabrication Facility was developed. Simulink has been used for over a decade as the platform of the SSPM. Capabilities include:

- Transient mass tracking of materials throughout the entire process.
- A variety of graphing and plotting capabilities for visualization.
- Embedded Matlab code which can be used for more complex calculations (like material balance and statistical tests).
- GUIs/Apps to allow the model to be shared with others.
- Data output into various desired formats.
- A variety of options to suit the user's need whether that may be NMAC design, analysis, or training.



LEU Fuel Fab Reference Facility

LEU Fuel Fabrication Safeguards Performance Model

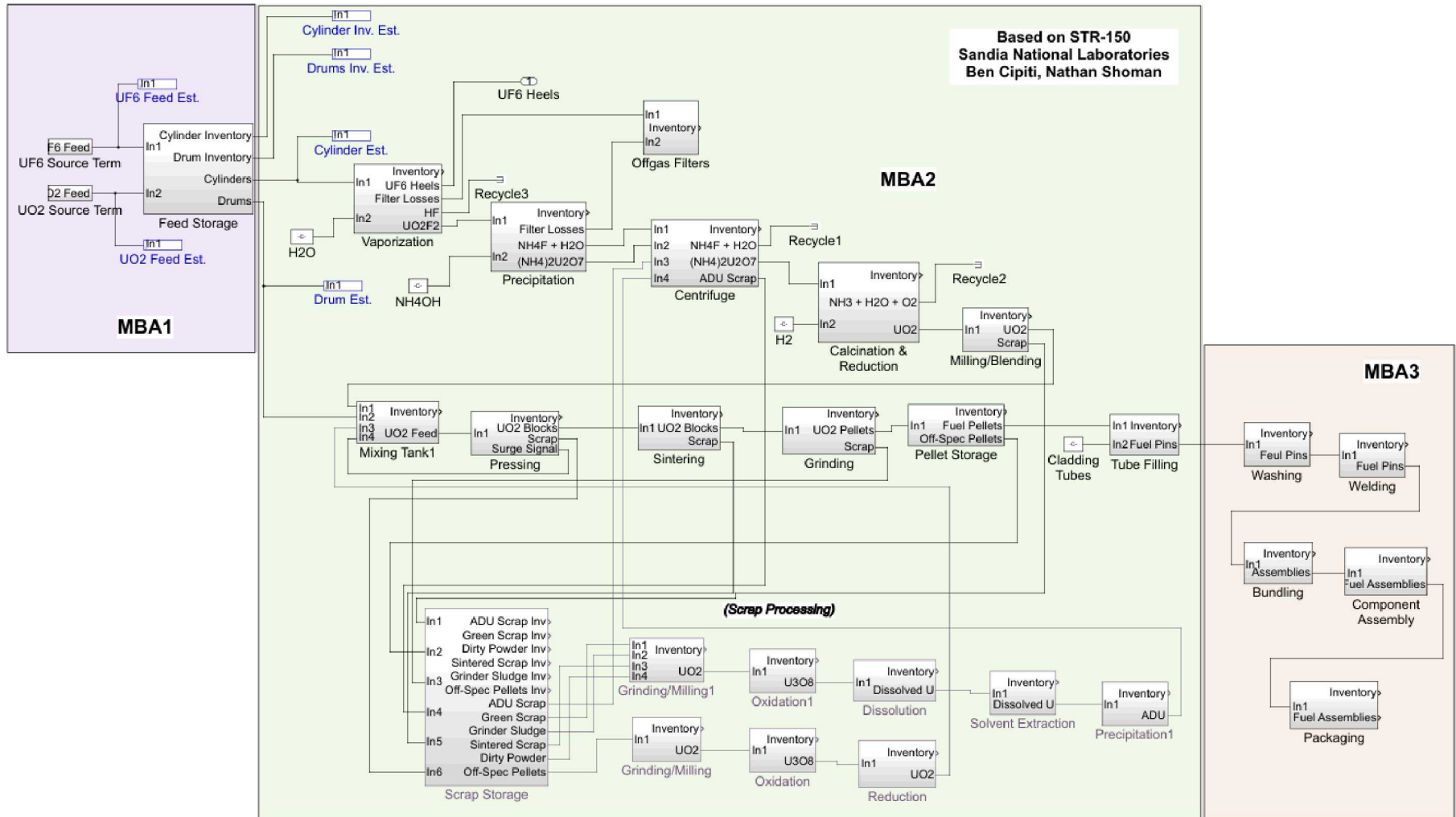



Basic Concepts for Modeling in Simulink



Signals

- **Simulink was designed for signal processing—in this case the signals represent mass flow rates as a function of time.**
- **The signals are arrays and can be as large as needed.**
 - **For an LEU fuel fabrication facility, the arrays may only track U and O and possibly some chemicals. For a MOX fuel fabrication facility, additional elements would be tracked.**
- **Continuous flow is represented as constant signals with time, and discrete inputs are represented as pulses of material.**

Unit Operation Blocks

- The unit operations are subsystems that manipulate the input signals.
- Most of the unit operations simulate inventory by integrating and adding the inputs and subtracting out the sum of the integrated outputs.

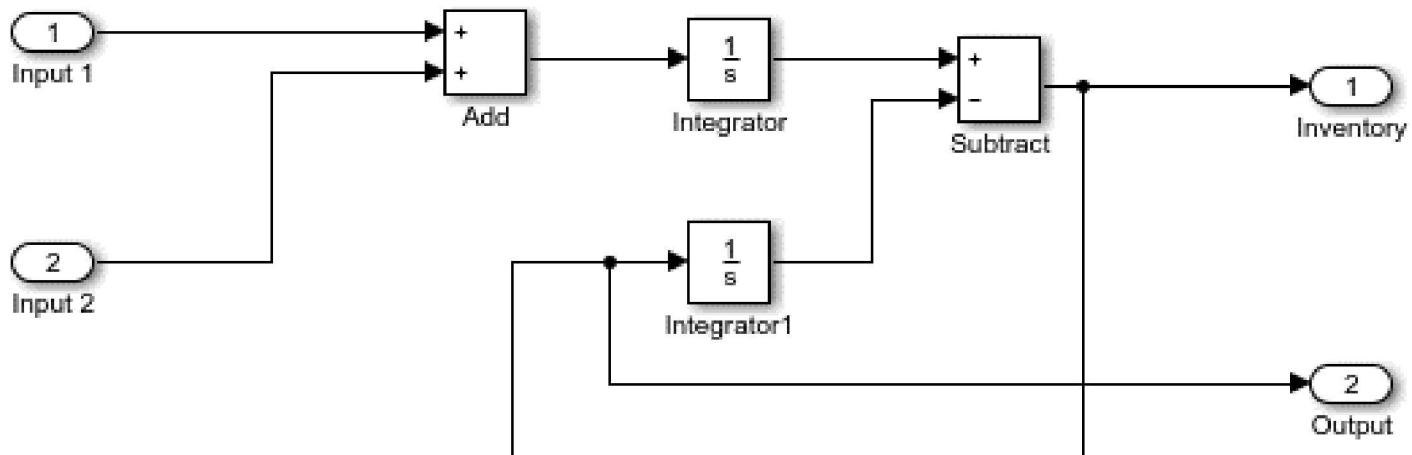

Simulating Accurate Processes

- The inputs or inventories in a unit operation are manipulated to simulate the functions of interest.
- Gain blocks are often used to determine chemical separations.
- Relays and switches are used as control functions to help model accurate tank filling and emptying.

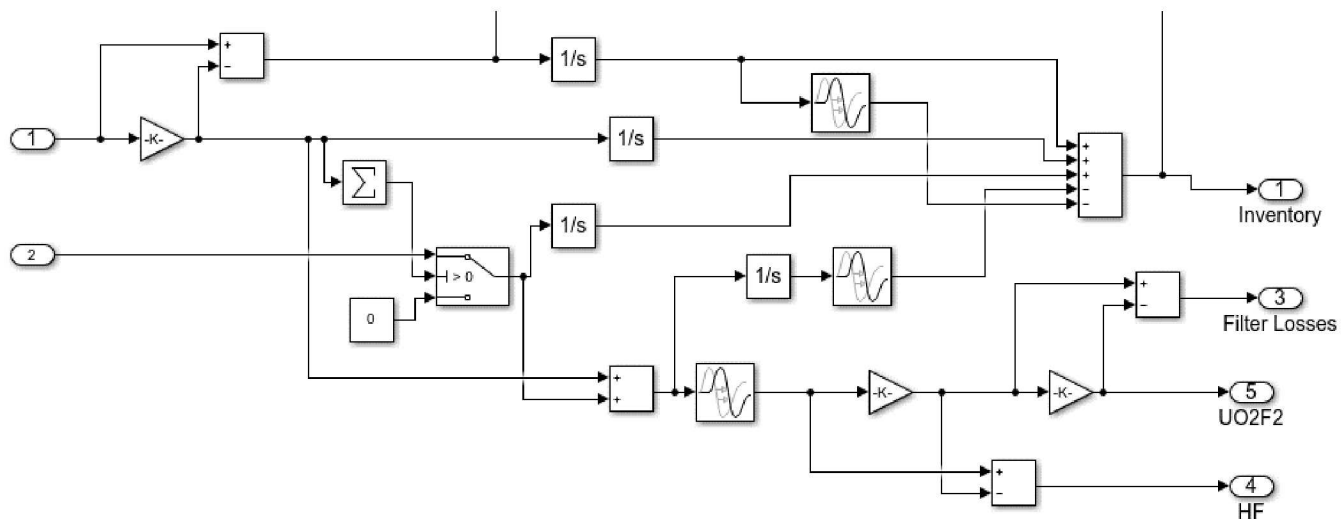

Advanced Control Functions

- Triggered and enabled subsystems are used for more advanced control. These subsystems turn on when certain events happen. They can also be used as counters to count input batches.
- Embedded Matlab functions can also be used when the programming becomes too complex for the Simulink block structure.

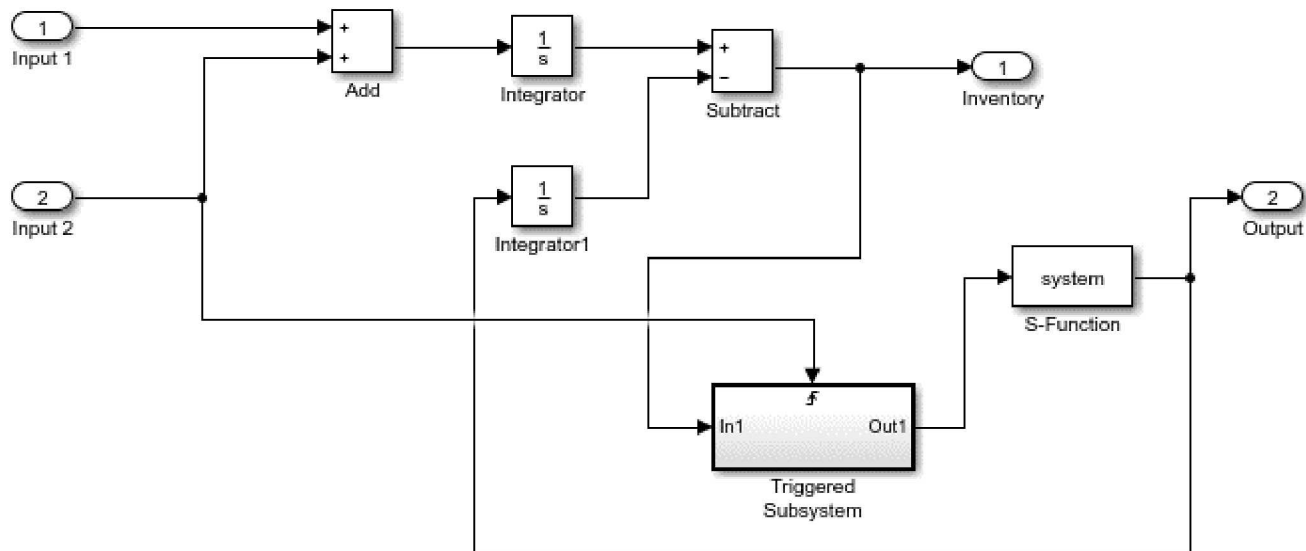

Most Commonly Used Blocks

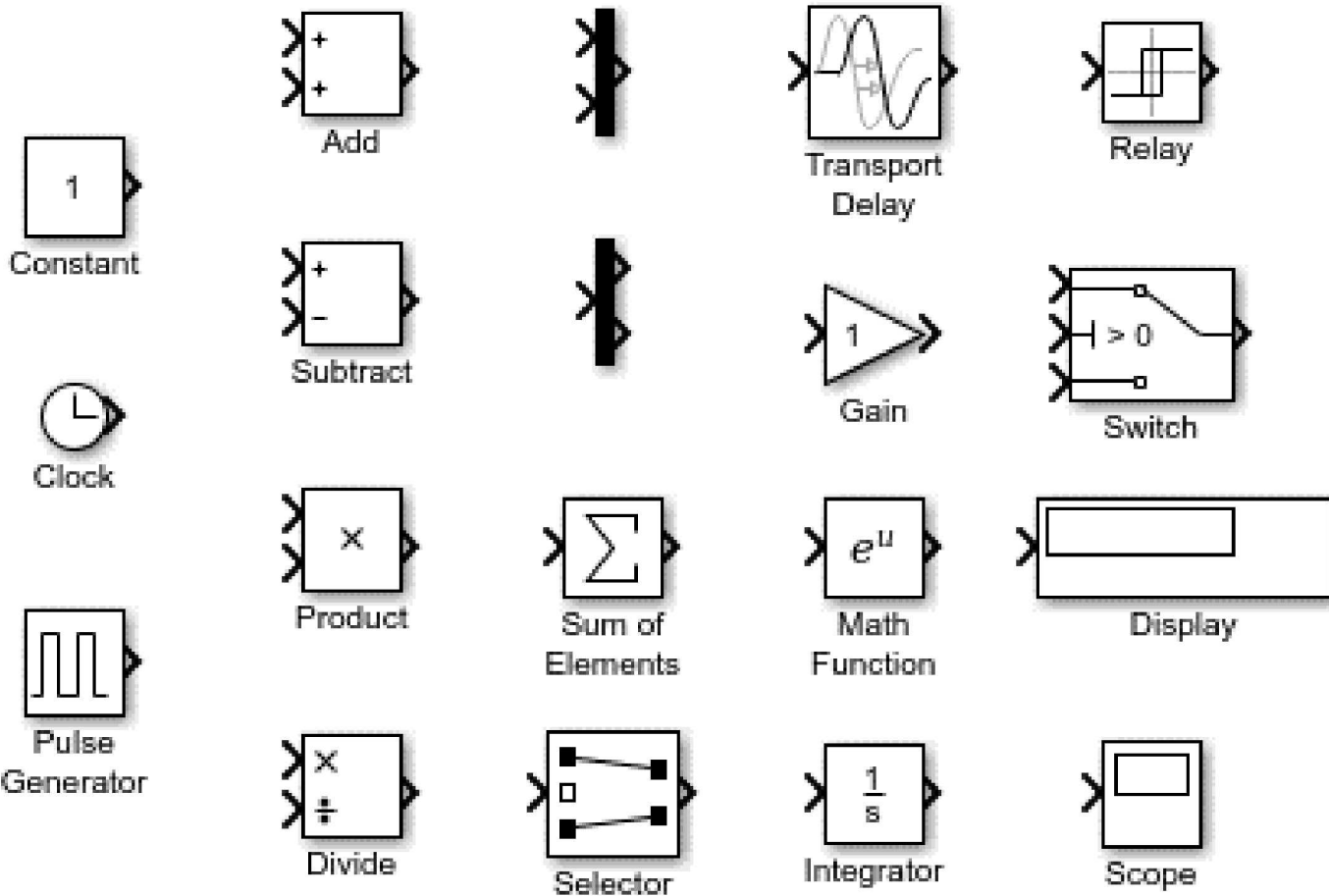



Unit Operation Overview

Source Term

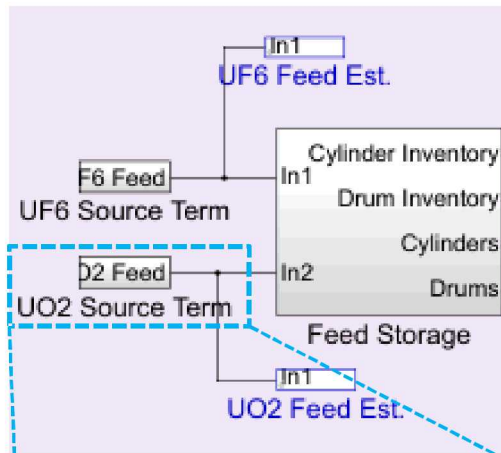

- The source term simulates the pulsed nature of UO_2 feed material entering the plant. (UF_6 cylinders would be similar.)
- The feed is multiplied by a pulse generator such that the total flow into the plant is equal to the design throughput (300 tons of UO_2 based on STR-150).
- The upper right of the block outputs the feed to a “to workspace” block, which stores the value in the Matlab workspace.

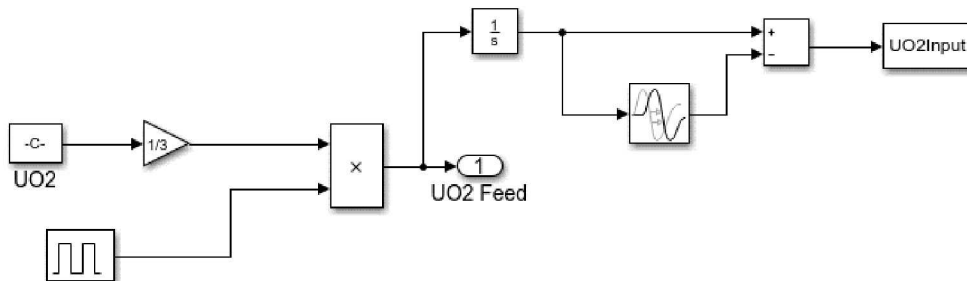

Feed Storage

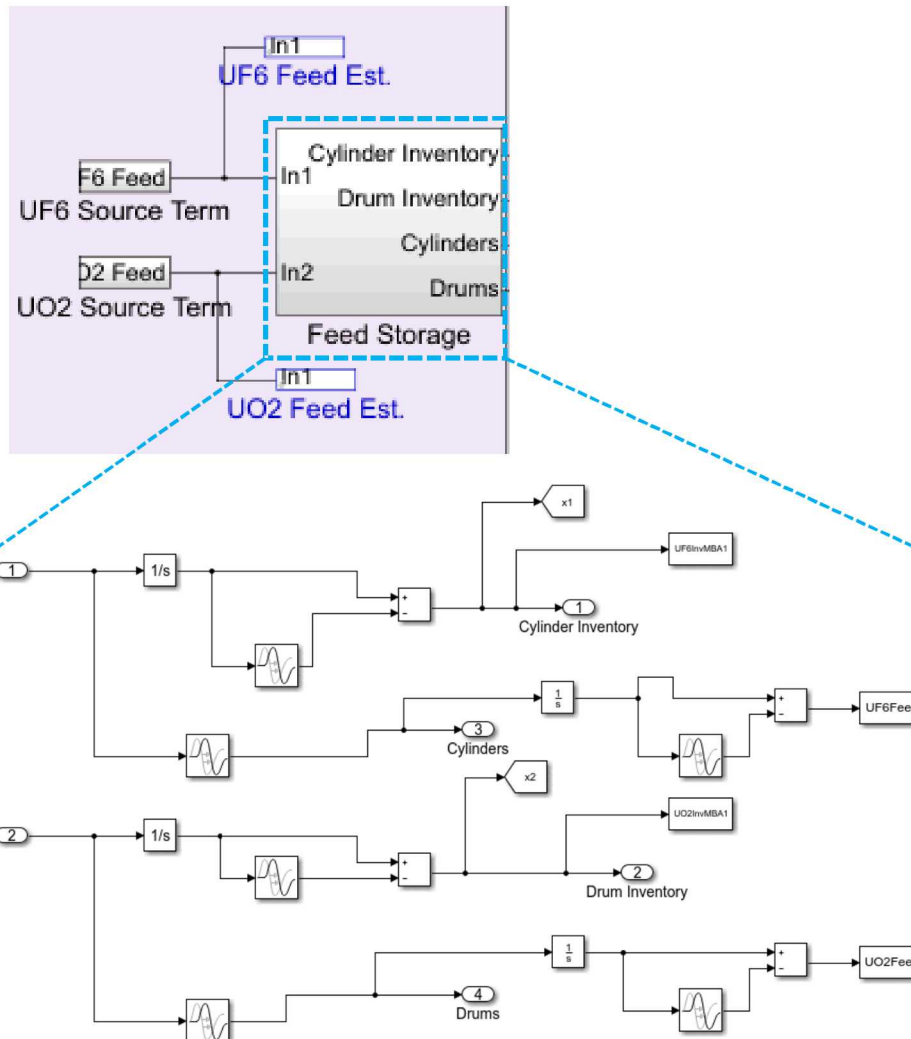

- Storage locations are typical in any fuel cycle facility.
- The feed signal is integrated to provide a total inventory over time.
- A transport delay is used to allow some quantity of feed material to buildup in storage. Note that the two transport delays associated with each input are set the same so that the integrated output is subtracted from the total inventory. This simulates an inventory for that area as a function of time.

Vaporization

- Unit operations that require chemical conversion or other losses of material use gain blocks to manipulate the signals.

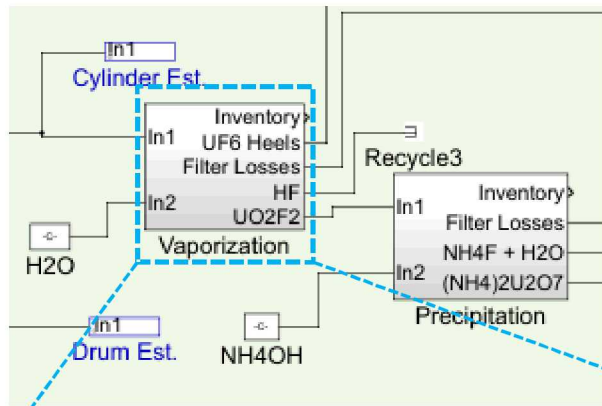

First gain block separates out a small fraction of UF_6 which remains in the cylinders as heels.

The integration and adding of all signals models a completely mixed vessel, so the gains determine which elements or which fraction of elements goes to particular outputs.

Second gain block sends the correct amounts of U, O, and F to the main product stream. The remainder is the HF output which will be recycled.

Third gain block sends a small fraction of the output to filters.

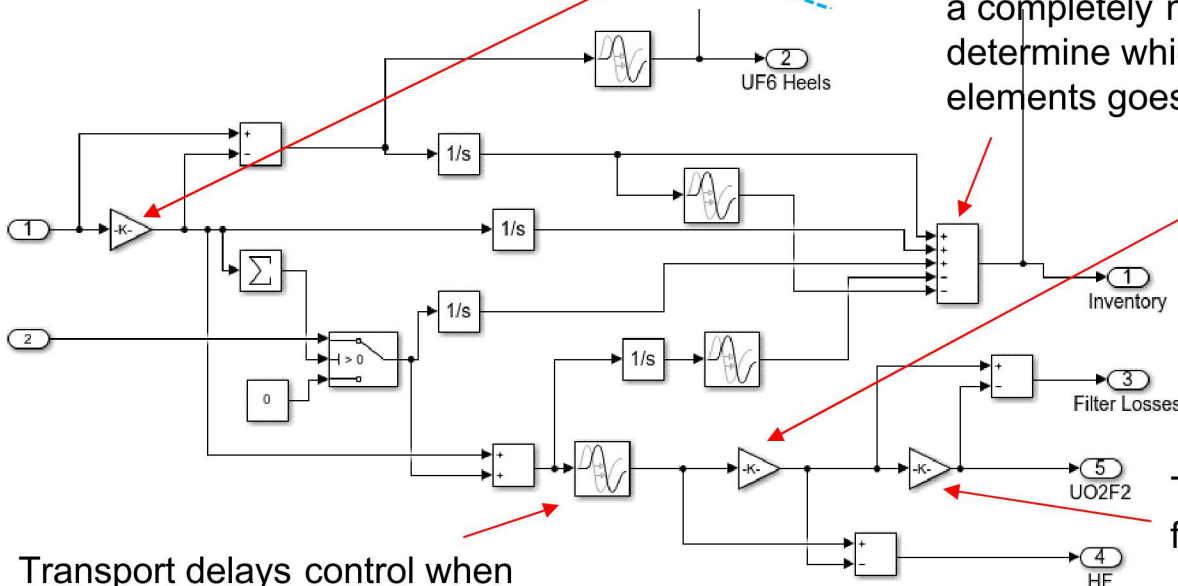

Transport delays control when materials are output

Precipitation

- Most of the unit operations follow a similar structure to what has been shown previously. Once the basic concept is understood, the rest of the plant model can be developed fairly quickly.

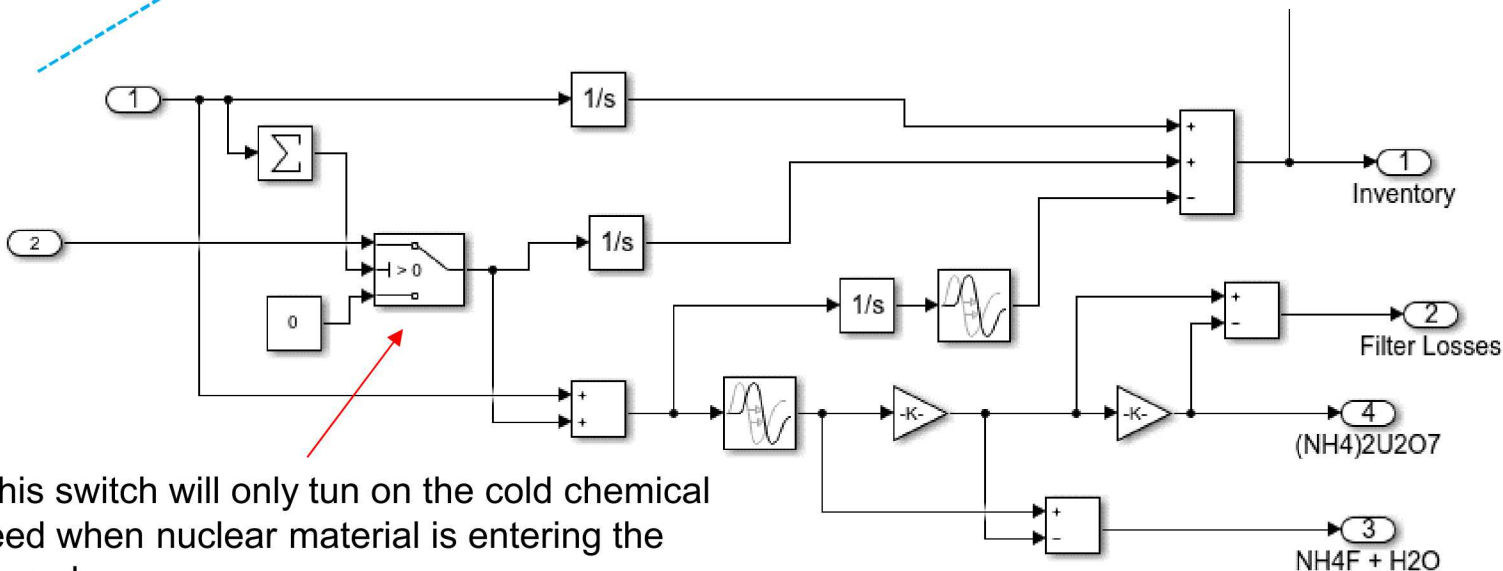
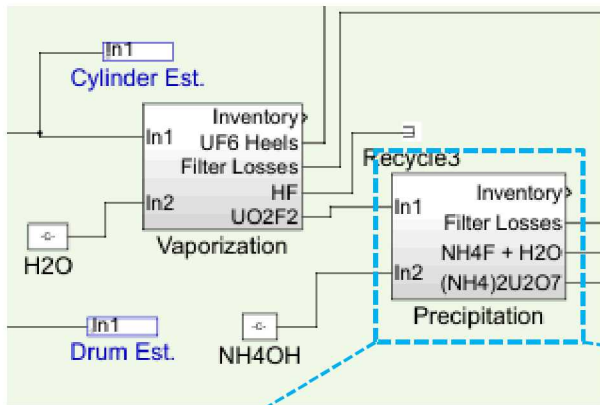

This switch will only turn on the cold chemical feed when nuclear material is entering the vessel.

Centrifuge



- There are multiple ways to model a given unit operation. The centrifuge shows an example of using triggered subsystems. The enabled subsystem triggers off some event and passes a new value or performs a calculation at that time, but then the value is held until the next trigger point.

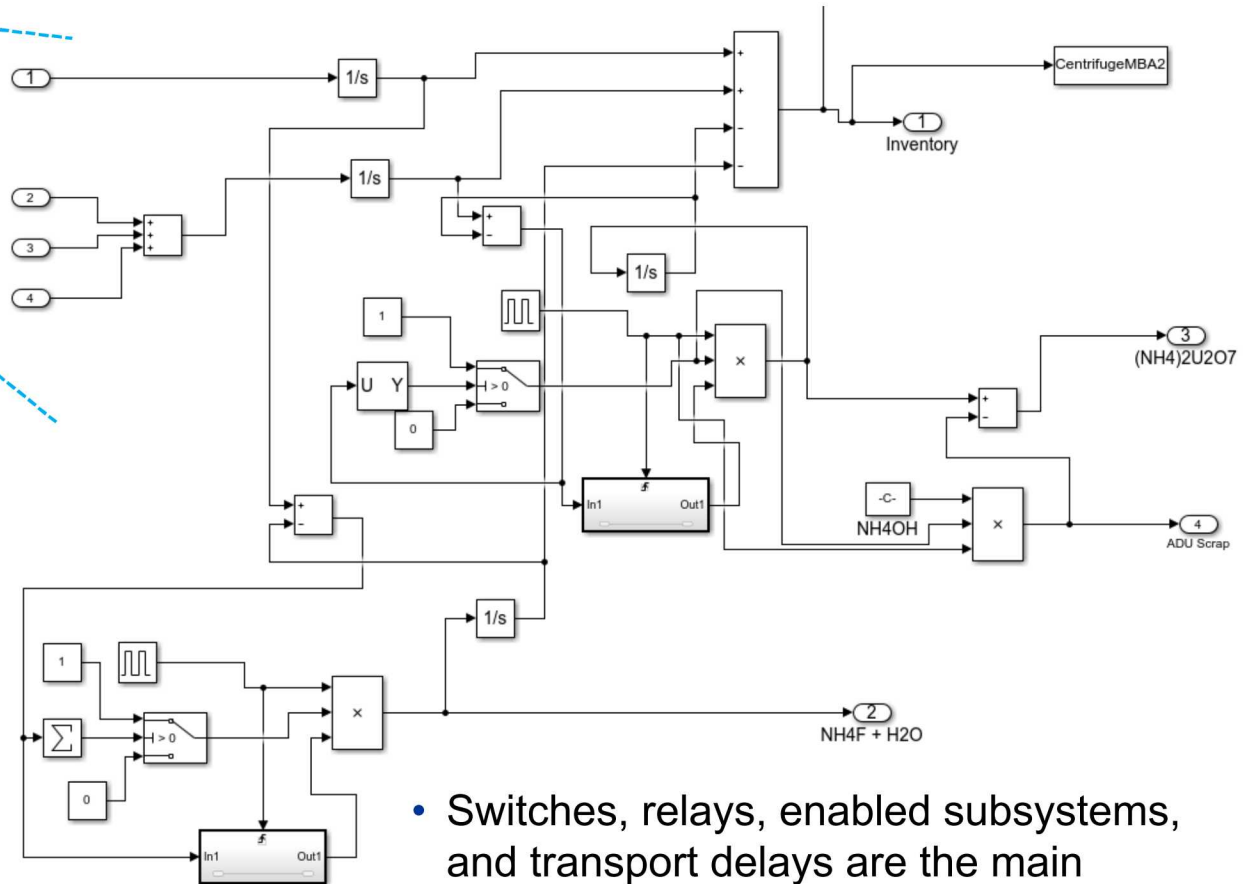

- Switches, relays, enabled subsystems, and transport delays are the main functions which control how and when material outputs initiate.

Milling or Grinding Operations

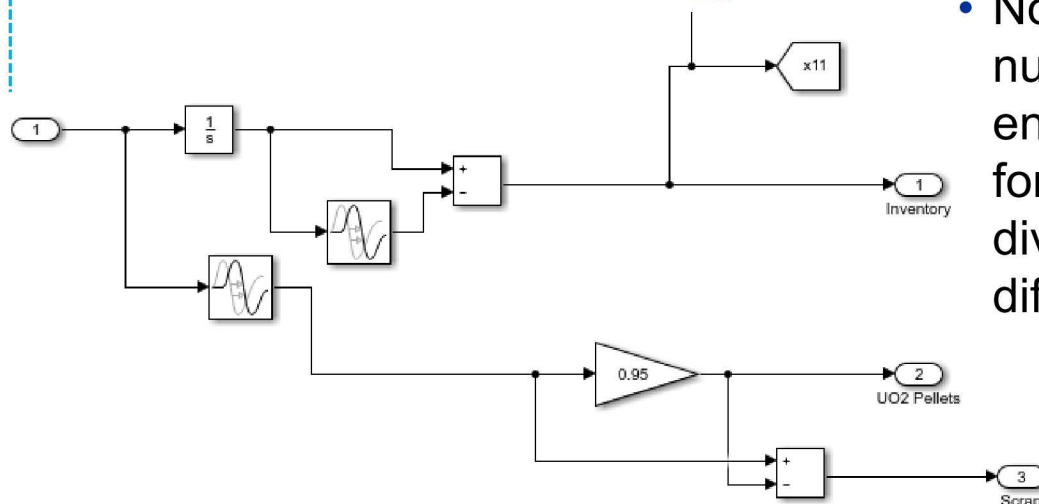
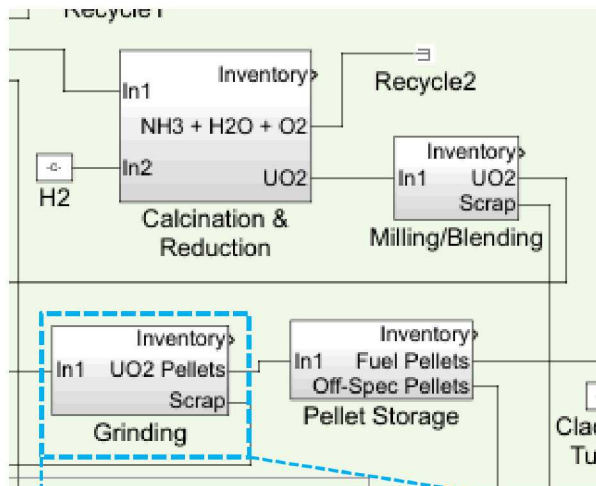

- Milling, grinding, or trimming operations are fairly simple and simply use transport delays to account for the time the material is in the process.
- A gain block is used to send a certain percentage to scrap (perhaps 5%).
- Note that gain blocks can be one number that is applied to the entire array, or a separate gain for each array element that diverts different elements into different streams.

Pellet Storage

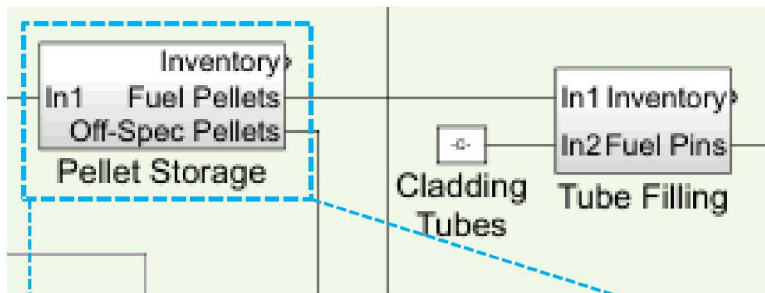

- Instead of using transport delays, the pellet storage area is designed to store pellets until there are enough for a full assembly.
- A relay is used to only turn the output on once that mass of pellets is reached.

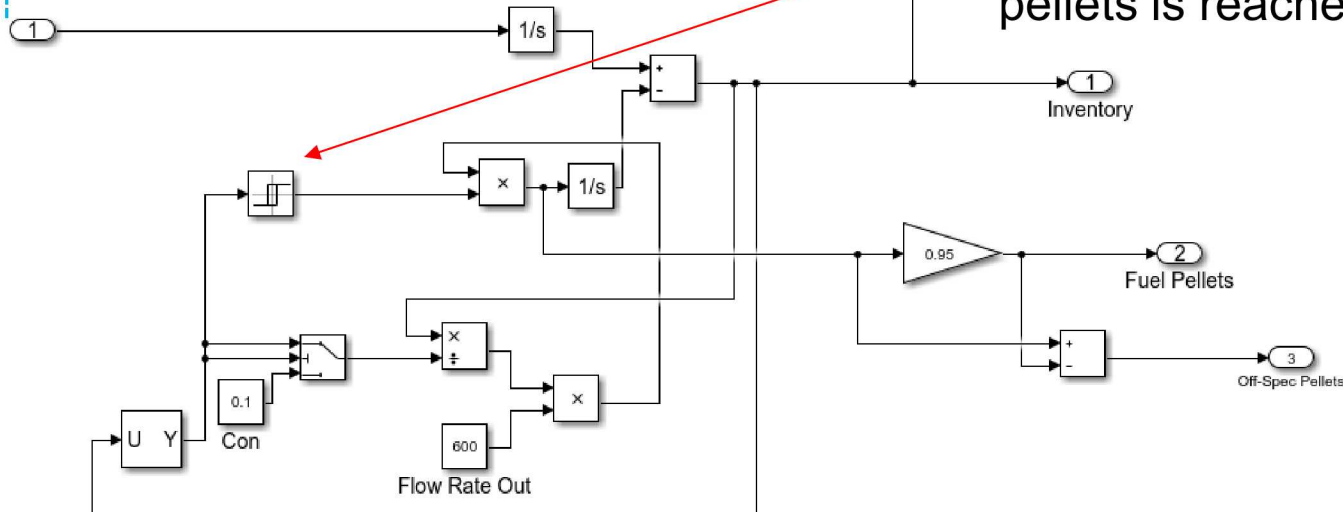



Finishing the Model

- **The rest of the operations are all very similar to previous ones shown, so knowledge of the basic setup of these blocks will allow for the rest of the plant model to be completed.**
- **The scrap processing area has many of the same types of unit operations as in the main process flow.**
- **MBA3 is batch processing, and many unit operations are fairly straight-forward.**



Use Scopes to Check the Model Operation

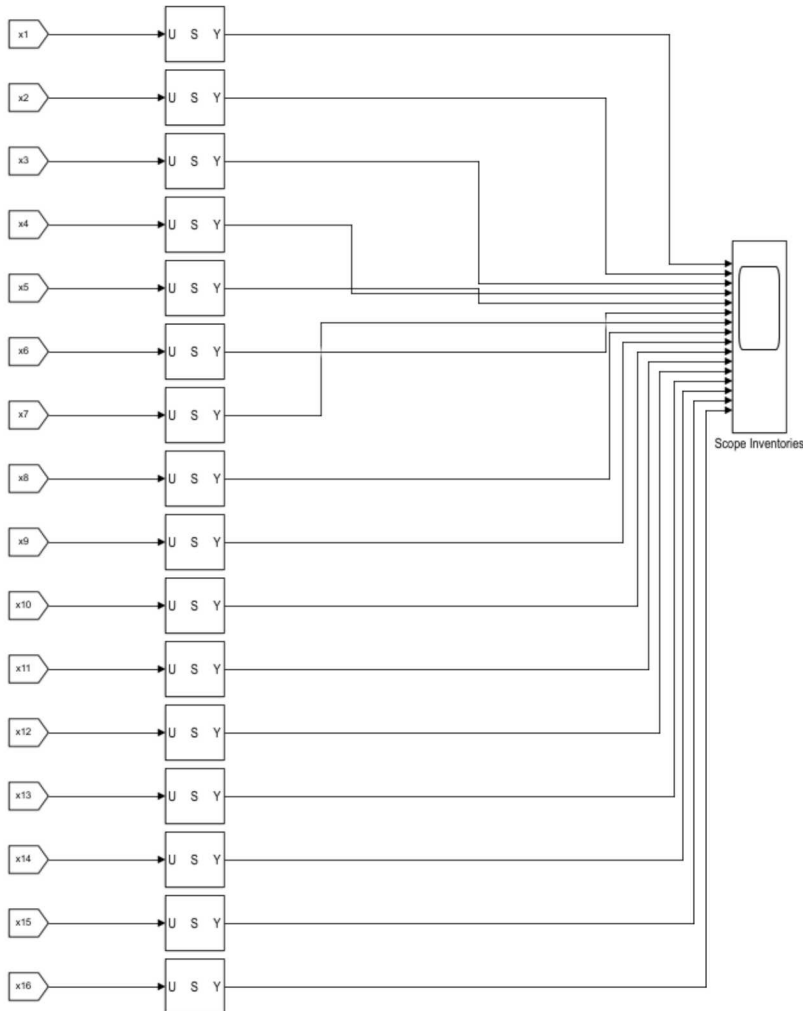

- A 'Goto' block can be used to extract signals from the various unit operations (like inventory).
- 'From' blocks can pull all this information into a scope to check the progress of the model.
- Note that 'selector' blocks are used to only plot a particular element (like Uranium).
- It's a good idea to check each unit operation as a function of time by running the model before moving on to the next.



Example Model Inventories

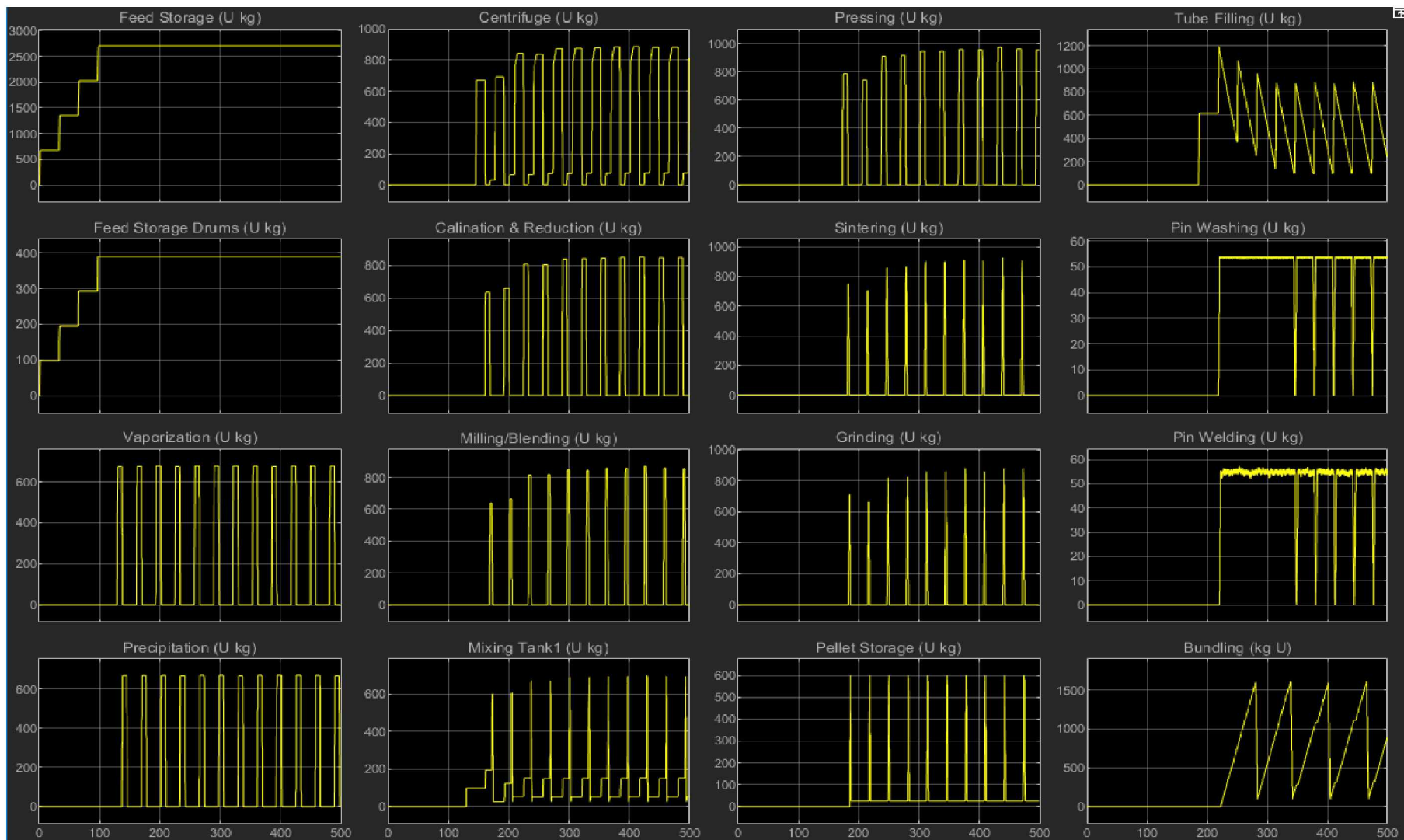



Future Work

- **A good first step is to build a generic plant model and make sure all the unit operations act as expected. The model can be simplified and expanded later.**
- **Material measurements and statistical analyses can either be added to the model or done using a stand-alone code. This choice is dependent on how the model will be used.**
- **In the future, we can discuss specific research needs to determine the best approach.**