

Sandia National Laboratories NSTTF Gen 3 Topic 1 CSP Liquid-Pathway to SunShot DE-FOA-0001697

Milestone (ST-1.3.2.1) Heat Trace Options Report



Developed with
Sandia National Laboratories
Albuquerque, NM



Sandia National Laboratories is a multimission laboratory managed and operated by National Technology & Engineering Solutions of Sandia LLC, a wholly owned subsidiary of Honeywell International Inc. for the U.S. Department of Energy's National Nuclear Security Administration under contract DE-NA0003525.

April 11, 2019
B&P Project No. 7828
SNL Project No. 1981795

TABLE OF CONTENTS

EXECUTIVE SUMMARY	iii
SUMMARY OF PIPE HEATING SYSTEMS.....	1
CERAMIC FIBER HEATER.....	2
SYSTEM DESCRIPTION	2
INSTALLATION REQUIREMENTS	4
TEMPERATURE CONTROL.....	5
RELIABILITY SURVEY	6
PRE-CONSTRUCTION VERIFICATION TESTING	14
MINERAL INSULATED (MI) CABLE.....	7
SYSTEM DESCRIPTION	7
INSTALLATION REQUIREMENTS	7
TEMPERATURE CONTROL.....	10
RELIABILITY SURVEY	10
IMPEDANCE	10
SYSTEM DESCRIPTION	10
INSTALLATION REQUIREMENTS	11
TEMPERATURE CONTROL.....	12
RELIABILITY SURVEY	12
INDUCTION.....	12
SYSTEM DESCRIPTION	12
CONCLUSION.....	19
APPENDIX A.....	21
APPENDIX B.....	26

**TABLE OF CONTENTS
 TABLES**

Table 1: Piping System Design Parameters.....	1
Table 2: Pipe Preheating System Summary.....	2
Table 3: Thermal Transport Risk Registry Forecast Based on Phase 1B Proposed Work	17
Table 4: Viable Pipe Preheating System Options	19
Table 5: CF Heater vs. MI Cable Installed Cost Comparison.....	20

**TABLE OF CONTENTS
FIGURES**

Figure 1: Ceramic Fiber Heater3
Figure 2: Ceramic Fiber Heater5
Figure 3: Pyromation Type E Thermal Couple6
Figure 4: Phase 1B Test Setup for Thermal Transport Pipe Heating Investigations.15
Figure 5: Mineral Insulated.....7
Figure 6: MI Cable Serpentine Pattern Detail8
Figure 7: MI Cable Serpentine Pattern Formed onto Pipe8
Figure 8: MI Cable Piping Serpentine Installation Attachment Wires.....9
Figure 9: MI Cable Attachment Followed by Foil, Ceramic Blanket, 2 Layers of Perlite ...10
Figure 10: Impedance Heating System.....11
Figure 11: Inductance Heating System.....13

EXECUTIVE SUMMARY

The primary objective of this report is to determine a viable pipe preheating system for a chloride-salt blend (40%MgCl₂/20%NaCl/40%KCl) that can preheat the pipe to 450 °C and withstand a maximum exposure temperature of 740 °C. Preheating involves heating the pipe to a specific desired temperature, called preheat temperature, of the pipe. The temperature is maintained by heated molten salt flowing through the piping system. This report reviews 5-types of pipe preheating systems, of which three pipe preheating systems- MI cable, heat tape, and ceramic fiber heaters, were found to be viable for the Gen 3 Liquid Pathway application. The report reviews the pipe preheating efficiency of conduction verses radiant heat transfer. For each of the 5 types of pipe preheating systems, the report describes the system and addresses installation requirements, temperature control, reliability survey, and pre-construction verification testing for the most applicable preheating system. Under Appendix A, images from design drawings demonstrate pipe routing with the preheating system and insulation attached to the pipe along with pipe guides and pipe supports, as designed using Caesar II finite element analysis within the SNL NSTTF Solar Power Tower.

Based on the market availability research conducted, it is believed there is only one system, the ceramic fiber (CF) heater, that can be exposed to 750 °C hot salt temperatures and not reduce the service life of the pipe preheating system. The maximum exposure temperature for mineral insulated (MI) cable de-energized is 593 °C with a maximum operating temperature of the MI cable of 482 °C. There is a significant difference between the MI cable and ceramic fiber heater installation requirements. The MI cable high installation labor effort is summarized as follows: a 2-dimensional serpentine pattern is formed with the MI cable over a jig then the serpentine cable is placed over the pipe to bend into a 3-dimensional pattern and attached with stainless steel wire to the pipe. Multiple cables are then attached to the pipe one at a time, this process is very labor and time intensive due to overlapping wires. MI cable labor effort is significantly higher compared to placing two CF heater sections over the pipe and securing in place with two ½” wide stainless-steel bands that tighten over a heater vestibule (Figure 1 & 2). Previous MI cable and insulation installation costs for the Molten Salt Test Loop (MSTL) were compared to the estimated costs for the CF heater including insulation. The results are summarized in the following table:

CF Heater vs. MI Cable Installed Cost Comparison					
Pipe Heating System	Heater Initial Cost	Heater Installation Cost	Insulation Installation Cost	Contractor Markup	Total Installed Cost (Full Contractor Markup)
Ceramic Fiber	\$400-\$700 / ft.	\$75 / ft.	\$190 / ft.	1.3	\$865 - \$1255 / ft.
MI Cable	\$150 / ft.	\$170 / ft.	\$388 / ft.	1.3	\$920 / ft.

The variance in the CF heater initial cost is due to manufacturer’s concerns over the quantity of unknowns in items such as elbows. CF supplier Thermcraft is capable of manufacturing CF heater elbows, but they cost more than a straight section. There are approximately 700 ft. of 2-1/2” molten salt pipe and 350 ft. of 1-inch ullage gas equalizer pipe anticipated in the project. As the design becomes better defined, the CF heater cost variance will be reassessed. At this time, it is not known what the valve and mass flow meter configuration and preheat requirements will be. This will also have an impact on the cost of the preheat system. MI cable could be used on the

cold salt piping system including cold valves and cold flowmeters. From an operational cost and maintenance viewpoint, it is believed the pipe preheating system should be the same for all piping systems. The CF heater is the only known reliable system which can be used to meet all requirements of the Gen 3 Liquid Pathway project. NREL's Bioenergy group has over 5 years of operational time using CF heaters to heat pipe and vessels to 500-1000 °C. Unless additional information is uncovered during the Phase IB and Phase II design period, it is recommended using CF heaters be specified throughout the salt piping network of the Gen 3 Liquid Pathway project.

Onsite testing (no salt followed by static salt filled tests) is recommended on small sections of similar pipe size in an outdoor environment such as at SNL MSTL site utilizing their existing LabView control system and Emersion Tyco heat trace control system before final system selection. Further explanation of pre-construction testing is provided at the end of this report.

SUMMARY OF PIPE HEATING SYSTEMS

The temperature requirements for the Gen 3 Liquid Pathway are much higher than previous molten nitrate salt applications. The current state-of-the art molten salt technology using nitrate salts in concentrating solar power projects operates at hot-salt temperatures of approximately 565 °C. The limit of nitrate salt thermal stability is approximately 600 °C with ambient air as the cover gas. Nitrate solar salts have operational ranges of 228 °C to 570°C.

Chloride-salt blends, such as 40MgCl₂/20NaCl/40KCl offer the potential to go to higher operating temperatures, 400 °C to 750 °C. The Gen 3 Liquid Pathway project proposes to use a ternary chloride-salt blend.

The Gen 3 piping system design parameters are as follows:

Piping System	Max. Temperature	Min. Temperature	Flow Rate
Cold Salt	500 °C	450 °C	84 GPM
Hot Salt	750 °C	450 °C	84 GPM
Ullage Gas Equalizer	500 °C+*	450 °C	30 ft ³ /min.

**Note: The ullage gas may be heated by ceramic fiber heaters with respect to the hot leg of the system.*

Table 1: Piping System Design Parameters

Based upon the proposed design parameters for the Gen 3 Liquid Pathway and the design temperature capabilities of available ultra-high temperature pipe preheating systems, the most promising pipe heating method identified is ceramic fiber heaters. These heaters rely on radiant heat transfer that is achieved by an electrical heating element which is embedded in ceramic fiber material that has a 1-inch air space between the heating element and the outer pipe diameter. The electrical heating element cannot come in contact with the pipe otherwise the heating element will sustain a ground short. Radiant heat transfer is more efficient than conduction heating since electrical energy is not lost on heating the surrounding material. The response time in preheating is significantly less (30 minutes depending on insulation), as less material mass is preheated when compared to alternative options.

Table 2 summarizes the different types of applicable pipe preheating systems reviewed in detail later in the report. Only pipe preheating systems capable of preheating piping systems to a minimum 450 °C were reviewed in detail.

The manufacturers recommendations for maximum operating temperature, maximum exposure temperatures, advantages and disadvantages of each pipe preheating system are tabulated below.

Pipe Preheating Method	Manufacturer	Max. Operating Temp.	Max. Exposure Temp.	Advantages	Disadvantages
Ceramic Fiber Heater	Thermcraft Inc., Watlow Inc., DS Fibertech Co.	1200 °C	1200 °C	Rapid thermal response due to radiant heating, higher operating temps, uniform heating distribution	Burn-in period to form aluminum oxide layer on heating element required during initial startup, high initial cost, contraction of 4% may occur at 1200°
Heat Tape	Brisk Heat	760 °C	760 °C	Rapid thermal response	Shortened service life at high temps, application for lab bench top
Mineral Insulated (MI) Cable	Chromalox, Raychem, Trasor	482 °C	593 °C	Traditional salt pipe heating system, low first cost for MI cable	Slow preheating due to conduction heating, insulation not available that does not become brittle when exposed to high temps, high installation costs, difficult to field cut
Impedance	Indeeco	875 °C+	875 °C+	High operating temperatures, uniform heating ramp-up rate	High initial cost, custom design; electrical isolation of piping components and pipe supports is difficult. Limiting factor is electrical conductor & connector.
Induction	Inductoheat	800 °C+	None	Very high operating temperatures, uniform heating rampup rate	Very expensive; difficult custom design, limited availability.

Table 2: Pipe Preheating System Summary

CERAMIC FIBER HEATER

SYSTEM DESCRIPTION

Ceramic fiber (CF) insulated heaters combine a heat source with high temperature insulation. Ceramic fiber heaters are designed for radiant heat transfer only and are capable of preheating piping and vessels to a maximum operating temperature of 1200 °C. The heaters consist of helically wound Fe-Cr-Al alloy resistance wire elements embedded in a rigid body of high temperature refractory ceramic fiber. The ceramic fiber insulation has very low thermal mass (160 – 240 kg/m³) and thermal conductivity (0.22 W/m °C at 1100 °C). Ceramic fiber heaters also have a high power density of 5-30 W/in² which allows the electrical energy to heat the load instead of losing energy on heating itself.

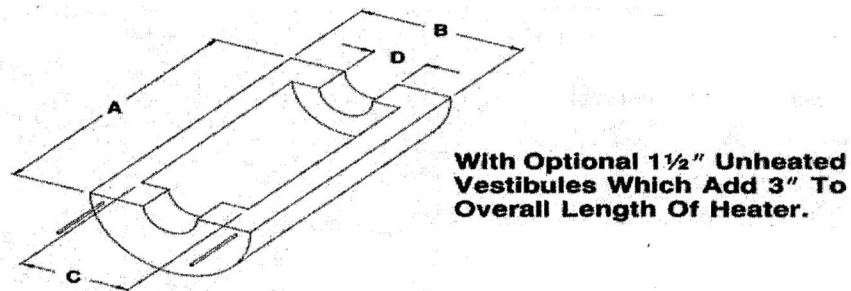
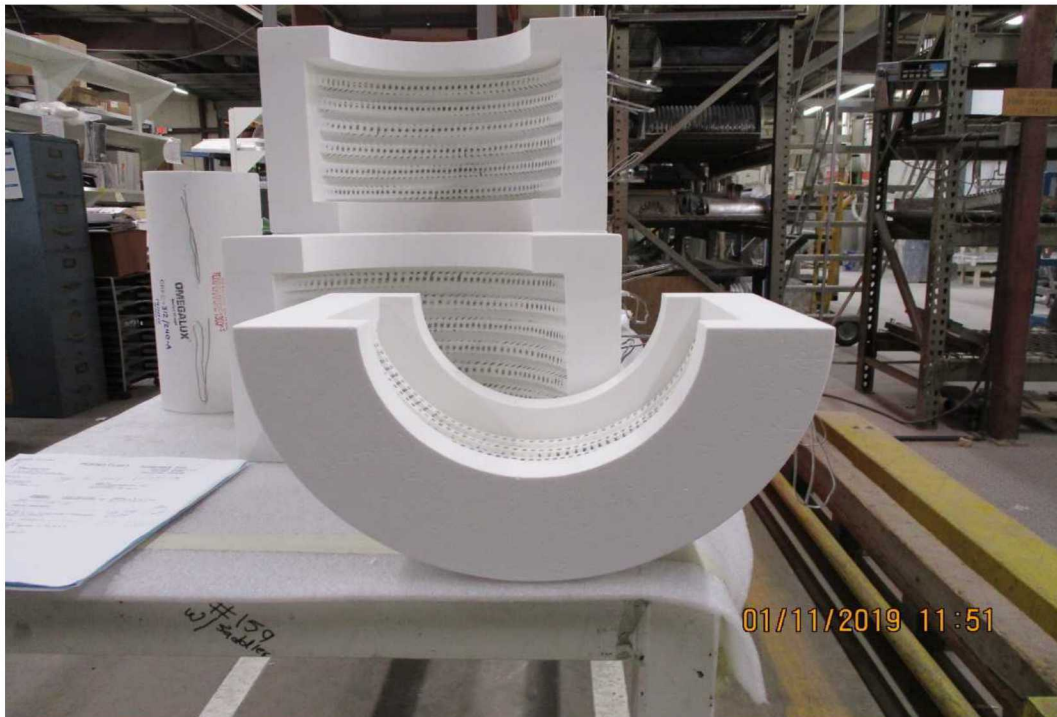

Figure 1: Ceramic Fiber Heater

Semi-cylindrical pipe heater sections are available in nominal standard lengths of 0.5, 1, 2, 4, 5, and 6 ft sections for nominal pipe diameters 1/2-inch to 12-inch size. The CF heaters are typically 1-inch thick with a 1-inch air space gap between the pipe outer diameter and the CF inner diameter. This air space allows for radiant heating of the pipe. Figure 1 shows a typical 1-inch thick CF heater. The CF heaters are manufactured for straight sections of pipe, short and long radius 90° elbows, and 45° elbows. Depending on the valve body configuration, the CF heater can be customized for the valve body either pre-forming the ceramic mold to the body or by custom built rectangular flat plate CF heaters. Valves with extended bonnets would use the typical pipe CF heater for preheating the valve bonnet. Piping tees would utilize a custom rectangular flat plate CF heater.

The CF heating element cannot come in direct contact with the pipe; otherwise the heating elements will short out. Vestibules are built into the CF heater at each end of the heater which fill in the air space allowing the CF heater to be supported by the pipe outer diameter. The vestibule is typically 1.5" thick and does not contain the CF heating element (Figures 1 & 2). A stainless steel band is wrapped on the outer side of the vestibule to bring the two semi-cylindrical pipe heater sections together. The CF heater when butted up against the next heater section has a total of 3-inches of unheated pipe length and will rely on heating by conduction during the pipe preheating thermal soak period. Because of the nature of ceramic fiber, there can be some shrinkage (less than 3%) when operating at 1200 °C but according to the manufacturer's it is hardly noticeable.

A burn-in procedure is recommended prior to use which helps ensure maximum life and performance. The burn-in procedure creates a protective aluminum oxide layer on the element wire, which increases the tensile strength of the wire, prolongs its life, prevents elongation and protects against chemical attack. The burn-in will drive out any moisture from the ceramic fiber. The burn in phase duration is approximately 3 hr and will occur during the initial start-up/commissioning period.

Mounting methods such as pins, screws and overlapping edge clamps may be used. Cementing is not recommended because it will not allow expansion or contraction. Due to the high porosity factor of the ceramic fiber heaters, the pipe surface must be free of contaminants that can vaporize at high temperatures and possibly damage the heating element.

The CF heater sections are wired in parallel, and the number of sections to be wired together is limited to the size of the desired electrical circuit and National Electric Code. CF heaters are available in single phase 120V and 240V. For the Gen 3 Liquid-Pathway at Sandia National Laboratories, 240V power would be utilized. Pipe can be preheated in as little as 30 minutes due to the maximum electrical element temperatures of 1200 °C, however operating at quick temperature ramp-up cycles will shorten the CF heater service life and exceed high temperature rating for stainless-steel pipe. For the Gen 3 application, quick temperature ramp-up cycles are not anticipated to be required; a 4-hour pre-heat cycle will require an operating temperature of 550 °C and allow adequate time for a heat soak of directly unheated areas. Field testing should be conducted to verify this calculation. Operating in this manner will significantly extend the CF heater service life.

INSTALLATION REQUIREMENTS

The ceramic fiber heater is one of the simplest of pipe preheating systems to install. The two semi-cylindrical pipe heater sections are placed inside diameter facing each other over the pipe. A ½" wide stainless steel band is wrapped on each end over the CF heater vestibule and tightened. The electrical connections extend beyond where the insulation will be placed. Approximately 4" of insulation wrap is applied to the outer CF heater and secured with stainless steel wire. A stainless steel outer jacket is applied. A separate Insulation Report will be developed that addresses the insulating method to be applied to the selected piping/heating system.

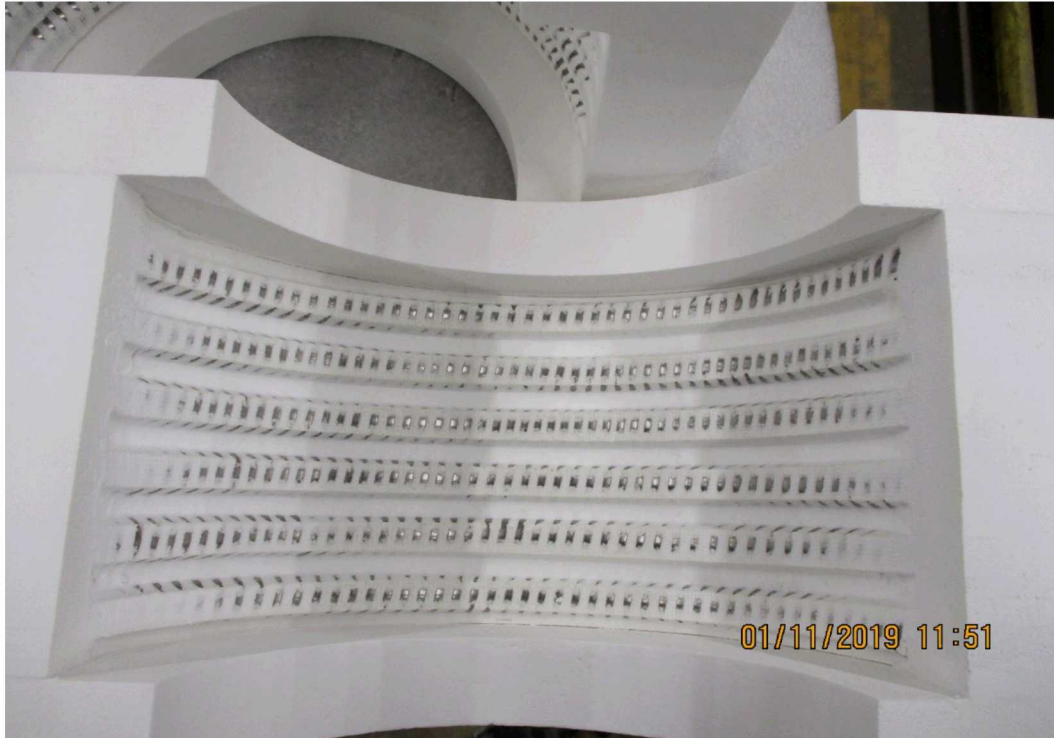

Figure 2: Ceramic Fiber Heater

TEMPERATURE CONTROL

Thermocouple manufacturer Pyromation was consulted for thermocouple (TC) application for CF heater control. Type K TCs are manufactured with a minimum hot leg length of 2". Locating a thermocouple in the CF heating area would measure the radiant heat emitted by the CF heater which would provide a false temperature reading. Pyromation recommends using Type E thermocouples which are manufactured with custom hot leg lengths with a radius attachment (weld pad) that would be tack welded to the pipe in the CF heater vestibule area (Non-heated, 1 1/2" thick vestibule). The thermocouple cold leg or thermowell will be fitted between two CF heaters vestibules. The remaining gap will be backfilled with ceramic fiber insulation. Penetrating the CF heater is not recommended. The Type E TC has a maximum operating range of 870 °C and can be custom ordered with any size hot and cold leg dimensions. Figure 3 reflects an edited Pyromation drawing for the proposed TC solution.

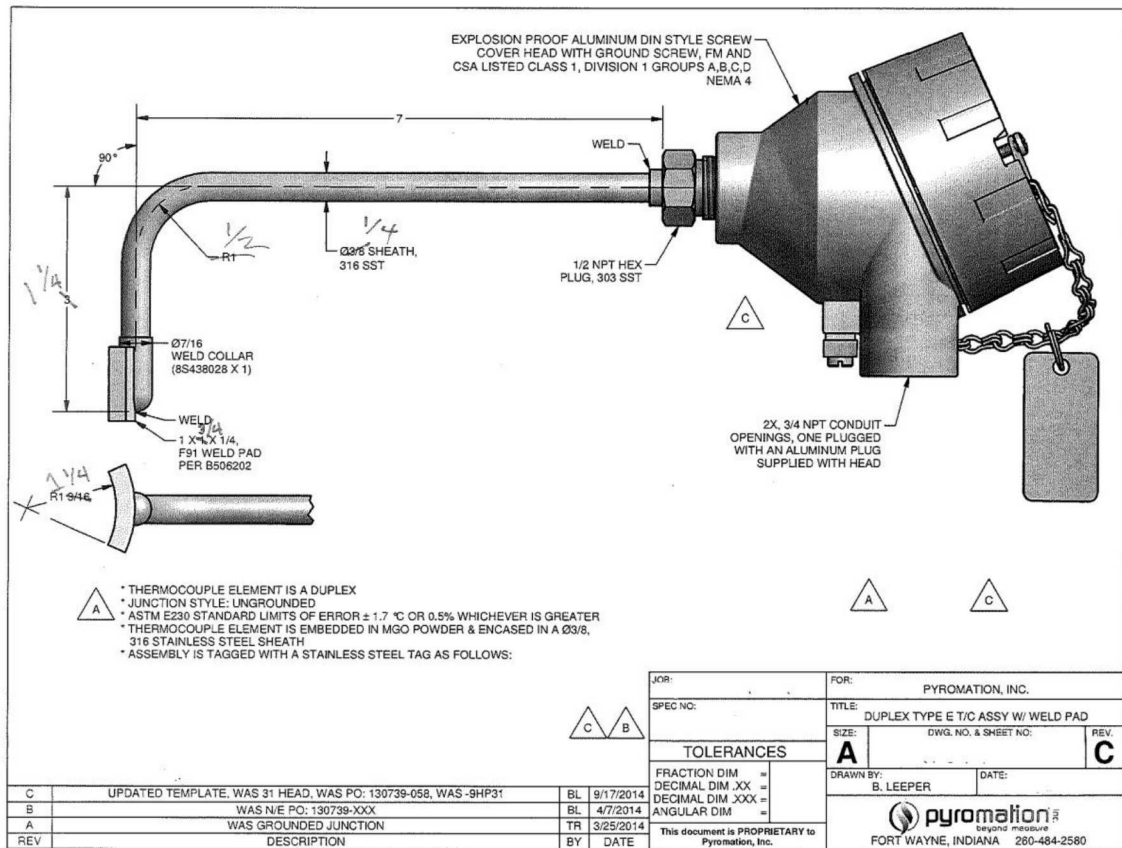

Figure 3: Pyromation Type E Thermal Couple

RELIABILITY SURVEY

The representative manufacturer of the CF heater, Thermcraft, provided a contact at NREL that has been using their ceramic fiber heater product (various pipes and vessel sizes) for over 5 years. The Thermal Catalytic Process Development Unit at NREL has been very forthcoming in answering questions concerning the reliability and performance of the CF heaters. NREL has currently over 50 CF heaters in operation in various configurations from pipe heating to vessel heating. Their piping systems and vessels materials are mostly manufactured from Inconel and some of stainless-steel 316. Currently piping and vessels are maintained in a “hot standby mode” at 400-500 °C, or the system is placed in a “auto heat mode,” which operates between 500 – 1000 °C, depending on the specific application. The systems are all indoors and not exposed to the outdoors. NREL does not like to cycle temperature cycles; therefore, the systems are maintained in either temperature mode and operated continuously. Currently SSR/SCR’s are used to control the heaters and operate on some applications at 100% power with no adverse effects. Thermal couples or thermowells are used to measure fluid temperature to control the CF heaters. The technician who responded to inquiries from B&P indicated he had not seen any of the CF heaters replaced in over 5 years. The only issues experienced was recent CF heaters installed utilizing twisted pairs of solid core wire that becomes brittle when exposed to high temperatures, something common with all types of electric heaters. NREL’s older CF heaters utilized wire bands which had no issues. A possible solution to protect the electrical connector is to route the connector in a conduit which is wrapped with a ceramic ultra-high temperature sleeve. The

protective sleeve is for areas where the electrical conductor is exposed to high temperature environments. The sleeve is rated for continuous operation of 1200 °C and intermittent temperatures of 1425 °C.

NREL has used two different manufacturers (Thermcraft and Watlow) to provide CF heaters over a 5-year period for different parts of their process, and both function well. There are instances where CF heaters are not used, and they have applied heat tape to obtain similar temperatures to those for the CF heaters; but due to the high temperatures, the heat tape is found to “burn out” quickly. NREL’s Thermal Catalytic Process Development Unit stated they prefer to use the CF heaters in their high temperature application.

MINERAL INSULATED (MI) CABLE

SYSTEM DESCRIPTION

Mineral insulated type KN cable has resistive heating conductors embedded in highly compressed magnesium oxide insulation and covered with a stainless-steel Alloy 825 sheath. The sheath is fully annealed and is hand formable. The low resistance metallic sheath is an ideal ground path. The MI cable is totally inorganic and will not deteriorate with age. The MI cable is tested to IEEE standards. The maximum exposure temperature for MI cable de-energized is 593 °C with a maximum operating temperature of the MI cable of 482 °C.



Figure 4: Mineral Insulated.

Single or double (shown) resistance wires. MgO mineral insulation. Alloy metal sheath.

Manufacturers have made improvements to enhance the MI cable heat transfer and reduce the sheath temperatures. Heat transfer cement is heavily applied over the MI cable. This installation method is often used in high wattage MI cable application. The heat transfer cement is rated to a maximum 677 °C.

INSTALLATION REQUIREMENTS

The installation requirements for MI cable are to first form the sections of MI cable into a serpentine configuration by placing the MI cable over a jig in order to develop the correct serpentine radius. The minimum bending radius of the cable cannot be less than 6X the cable diameter. The cable should not be bent within 3” of any hot to cold joint, termination or splice. The

cable must not be in contact or overlap an MI cable unless a stainless-steel mesh provides adequate separation per manufacturer's instructions. The cable is secured to the pipe with 1/2" wide stainless-steel bands or stainless-steel wire every 12"-18". A sample installation detail is shown in the figure below taken from the SNL Molten Salt Test Loop construction documents. This installation detail depicts a valve located on a straight section of pipe. The valve body is located where the MI cable changes from a serpentine pattern to straight cable pattern then reverts back to a serpentine pattern. Additional MI cables are indicated above and below the straight MI cable which depicts the MI cable extending up the sides of the valve body.

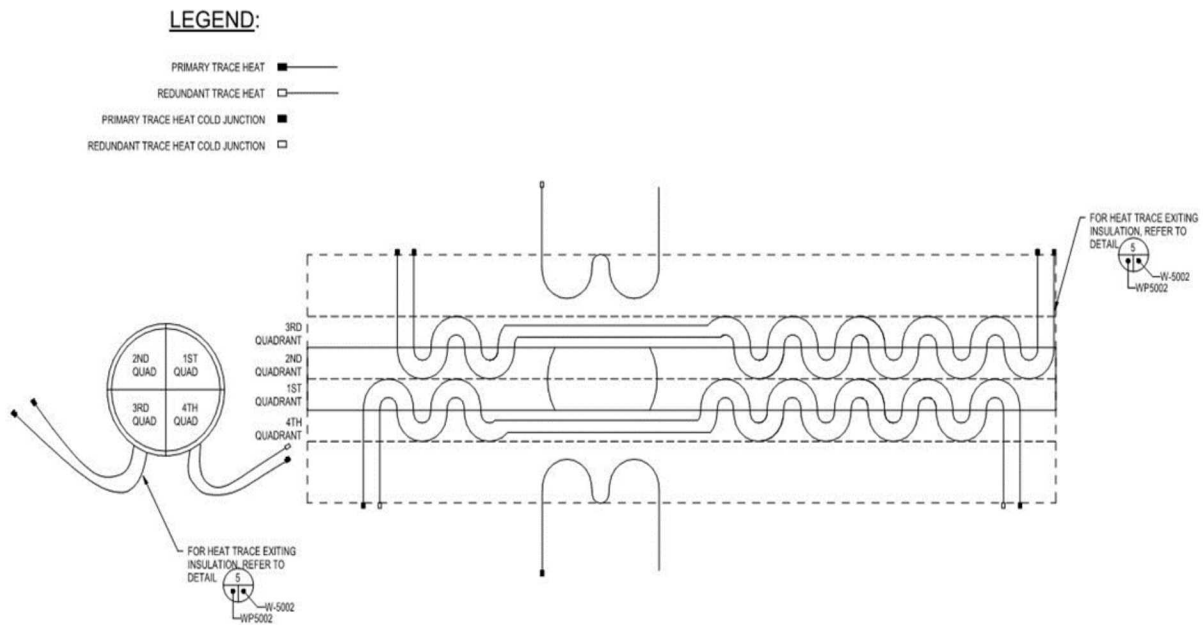

Figure 5: MI Cable Serpentine Pattern Detail



Figure 7: MI Cable Serpentine Pattern Formed onto Pipe

Once the 2-dimensional pattern is formed then the serpentine cable is placed over the pipe to bend into a 3-dimensional pattern (see picture above) and attached with stainless steel bands or wire as shown in the picture below from SNL MSTL project.



Figure 6: MI Cable Piping Serpentine Installation Attachment Wires

In high watt density applications, multiple cables are required to meet the necessary piping preheat conditions. The picture above is for a nitrate salt application where the preheat condition was 300 °C. This particular application required 4 MI cables per foot of pipe. Since only one cable can be attached at a time and must be secured to the pipe with stainless steel wire or band, the process is labor intensive due to overlapping wires as seen in the picture above. Once all the cable is attached, then a layer of stainless steel foil 0.003-inches thick is placed over the MI cable and attached with stainless steel wire (see Fig. 7). The purpose of the foil is to prevent the insulation from being in direct contact with the heated cable, and increase the heat dispersion effectiveness around the pipe. Insulation in direct contact with heated cable will cause the insulation to become brittle and become an ineffective insulator. Since the foil is also very hot, a 1 in. thick layer of ceramic blanket is wrapped around it to protect the pipe formed expanded perlite insulation which is applied in two – 2 IN. layers with offsetting seams/layer joints to allow for thermal growth. The purpose of the offset joints is to prevent having a direct heat path from the heated pipe to the environment. The final layer is the stainless steel jacket wrapped around the pipe/insulation system to protect from weather.



Figure 7: MI Cable Attachment Followed by Foil, Ceramic Blanket, 2 Layers of Perlite

TEMPERATURE CONTROL

Typical MI cable pipe preheating systems are controlled by the use of Type K thermocouples (TC) which are attached to the pipe with a “weld tab” (tack welding a 2”x2” formed cover plate over the TC hot leg to the pipe). The hot leg is located between the MI cable serpentine patterns. The Type K TC with alloy 600 sheath material has a maximum operating temperature of 1260 °C.

RELIABILITY SURVEY

Discussions were held with multiple industry experts in electrical heating of piping systems. One of the concerns pointed out is when operating MI cable near the MI cable’s maximum allowable exposure temperature, the MI cable magnesium oxide insulation becomes brittle over time even though it may not have surpassed its exposure temperature rating, thus reducing its service life. Also, it was pointed out that the industry might be able to make the magnesium oxide insulation thicker to extend the service life of the cable, but the fact still remains the magnesium oxide insulation will become brittle when exposed to temperatures near its maximum limit of 593 °C over time. Another issue is by making the MI cable insulation thicker, the MI cable becomes less hand formable thus increasing the odds of damaging it during installation.

IMPEDANCE HEATING

SYSTEM DESCRIPTION

Impedance heating uses the pipe itself as the heating element. Resistance to current flow generates heat. This provides uniform heat distribution with high heat-transfer rates and the ability to reach very high operating temperatures. A power transformer produces the correct

output voltage to produce adequate heat and safe operating conditions. Output voltages usually range from 1 to 30 volts and with operating currents of 600-1000A. Optional solid-state proportional control with fully modulated SCR, is also available for more precise temperature control. Terminal plates with cable lugs are supplied for field attachment to the pipe and low voltage power cabling. Flange isolation kits are used to confine the electrical current to the section of pipe being heated as shown below in Figure 8.

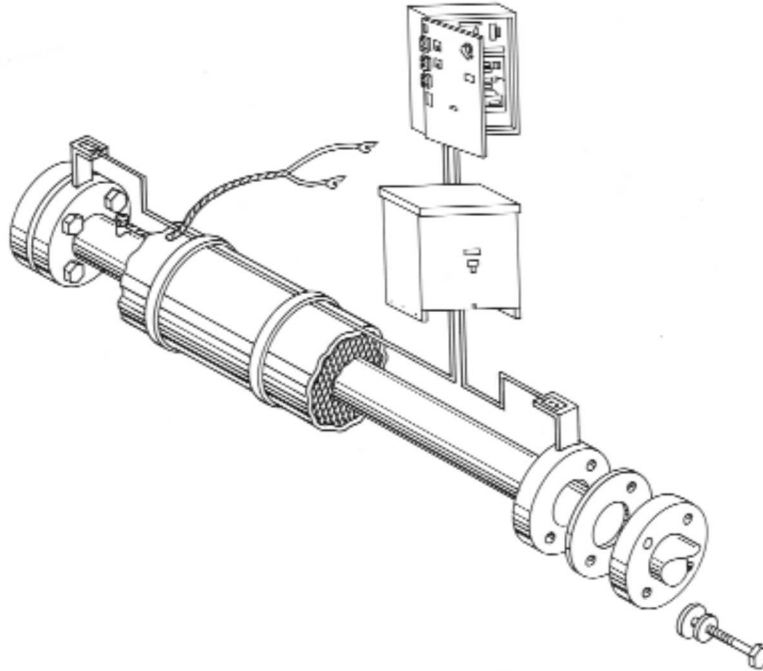

Figure 8: Impedance Heating System

INSTALLATION REQUIREMENTS

The pipe is the heating element in an impedance heating system. The electrical conductors and connections may be vulnerable to burnout if not properly isolated from the piping high temperatures. There is significant high amperage current (600-1000 A) flowing through the pipe; therefore, the entire piping system must be electrically isolated from the support structure and shielded from personnel contact. The sensitive electronics in control valves and flow meters must also be isolated from the current. While technically any voltage can be utilized, without special isolation and containment provisions the National Electric Code (NEC) limits impedance system designs to a maximum secondary voltage of 80 VAC. By keeping the system secondary voltage under 50 VAC, designers ensure the system will be safe for personnel working on and around the energized piping system. In addition, impedance systems utilizing a secondary voltage over 30 VAC must also have a ground fault protection system. Use of ground fault protection further heightens safety concerns should the energized pipe become grounded.

Pipe supports require electrical isolators to prevent the piping electrical current being grounded into the pipe support or building structure system. This can be difficult in some environments such as what happened on the SNL MSTL / AREVA testing of the Linear Fresnel CSP program. The boiler section piping which utilized impedance heating was unable to be fully electrically isolated from the 100 ft. support towers, hence the towers were electrified with approximately 3-4V. The

towers were grounded to the NSTTF underground counterpoise system which protected other systems from stray current. Therefore, all piping support systems would be connected to the existing NSTTF counterpoise system as is current Solar Power Tower.

As previously discussed, the valves and flow meters must be electrically isolated from the impedance piping heating system. In order to properly isolate the valves and flow meters, these two piping components must utilize flange connections with electrical isolator flange gaskets and flange bolt isolators. Due to the high wicking effect of chloride-salt blend, the use of flange gaskets and bolts would create a severe salt leak path.

TEMPERATURE CONTROL

Impedance pipe preheating systems are controlled by the use of Type K thermocouples (TC) which are attached to the pipe with a “weld tab” (tack welding a 2”x2” formed cover plate over the TC hot leg to the pipe). The Type K TC with alloy 600 sheath material has a maximum operating temperature of 1260 °C.

RELIABILITY SURVEY

Based on consultation with impedance heating system manufacturers the use of impedance heating in this type of application would involve high difficulty in determining a method to isolate valves and flow meters. Also, the valves and flow meter would still require a preheating method such as MI cable on the cold salt system and ceramic heaters on the hot salt system.

INDUCTION HEATING

SYSTEM DESCRIPTION

Induction pipe preheating systems use alternating current through an induction coil which creates an alternating magnetic field that oscillates at the same frequency as the coil current. 60 Hz AC will cause the magnetic field to oscillate 60 times per second and 400 Hz AC will cause the magnetic field to oscillate 400 times per second. This time-varying magnetic field induces eddy currents in electrically conductive objects in close proximity to the induction coil (Faraday’s Law of Electromagnetic Induction). The induced current also isolates at the same frequency; however, it flows in the opposite direction as the coil current (Lenz’ Law).

There are two mechanisms of heat generation that occur when heating materials and is associated with the magnetic hysteresis. Thermal energy (heat generation) is dissipated during the reversal of magnetic domains due to internal friction between molecules. Magnetic hysteresis heat generation is proportional to the applied frequency and the area of the hysteresis loop, which is a complex function of chemical composition, grain size, temperature, magnetic field intensity, and frequency.

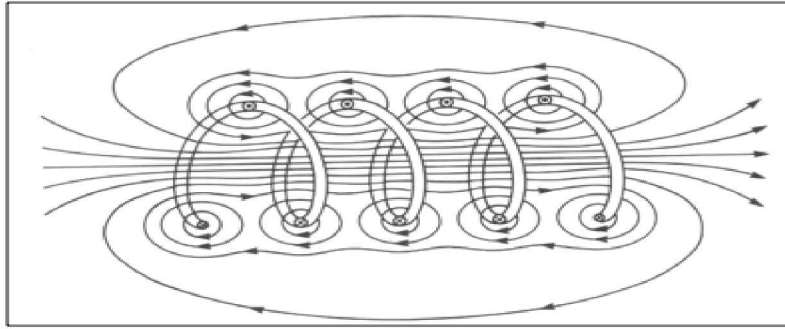

Figure 9: Inductance Heating System

Aside from very high temperature capabilities, the primary advantage of induction heating is the absence of thermal resistance between the heat tracing and pipeline. The pipeline can therefore be heated quite rapidly. Heat is generated without actual electrical contact between the wire and the structure. (A primary design consideration is that the coils being used often need to be thermally protected from the pipeline.) The disadvantage of induction heating is its expense. Each system needs to be specially designed. Power inputs are required at short intervals along the pipeline and material requirements are very large.

Achieving uniform temperature distribution would be a painstaking design process; coil spacing would have to be adjusted for every pipeline irregularity such as a valve or flange. Irregularities such as valves and flanges are difficult to design for in the system engineering. Care would have to be taken to ensure that any uneven heating caused by irregularities in the wall, coil or external flux path was tolerable.

Induction heating is most frequently used for melting metals, maintaining them in a molten state, stress relieving, annealing, normalizing and use on limited areas of piping systems. This system is not ideal for a large complex network of piping and various components. The induction system could be utilized in part for post weld heat treatment of field pipe welds on the Gen 3 Liquid-Pathway.

PRE-CONSTRUCTION THERMAL TRANSPORT HEATING VERIFICATION TESTING – PROPOSED PHASE 1B INVESTIGATION

The Gen 3 Liquid-Pathway project team requests approval to proceed with on-site verification testing of the ceramic heater to fully understand the limitations of the CF heater for this molten salt pipe preheating application. This also may include testing with different piping materials and schedule thicknesses (i.e. Sch. 40 and 80). Assessment will also need to be performed to address thermal-mechanical expansion concerns for the gap spacing between the heating system and the pipes for bends, elbows and valves. The SNL Molten Salt Test Loop (MSTL) has an Emerson Tyco MI cable heating control system which is controlled by a National Instruments LabView control system. This system LabView control system would be modified to control ceramic fiber heaters. We would recommend constructing a 2-1/2" ID piping test stand similar to Fig. 4, with CF heaters and insulated for various operational-mode testing, such as that for start-up, shut-down and contingencies. This investigation would also be adapted to include tests with and without static molten salt to assess heat transfer ramp rate impacts with the heating system and with the pipes, as well as thermal-mechanical fatigue based on thermal-cycling and continuous high-temperature operation. This would provide real data concerning installation, control, preheating time requirements and environmental effects on the pipe preheating system. Various insulation strategies could also be evaluated under this on-site testing.

The test stand, will also assess heating of fittings, with and without molten salt in a static configuration, shown in Fig. 10, where the tests under different thermal ramp rates and continuous high-temperature operation will help to understand the reliability impacts of the heating systems on different piping and heating system configurations. As shown in the figure the test system will include fixtures holding the piping both from above and below the piping. The system will have two legs joined by a central tee for assessing different piping materials, piping lengths joined by vestibules and pipe heating configurations. The system will also include three vertical towers where different cover gas chemistries can be assessed for compatibility with the molten salt. For these tests, two of the vertical piping legs on either side of the tee will be capped just before the elbow to not allow contamination of the rest of the piping system. The salt will be filled through each of the vertical legs where a cover nitrogen cover gas will be imposed. Variable N₂ purity tests are anticipated to assess impacts of N₂ purity on salt and pipe heating, as well as impacts on welds. Nitrogen metering valves and regulators will be incorporated with each of the three legs for regulation, where isolation caps will be placed just below the vertical legs with variable N₂ purity. The legs could also be used as active ullage gas equalizer piping to study the effects such as salt wicking, salt vapor and partial salt freezing effect within the ullage gas pipe at the interface with molten salt piping.

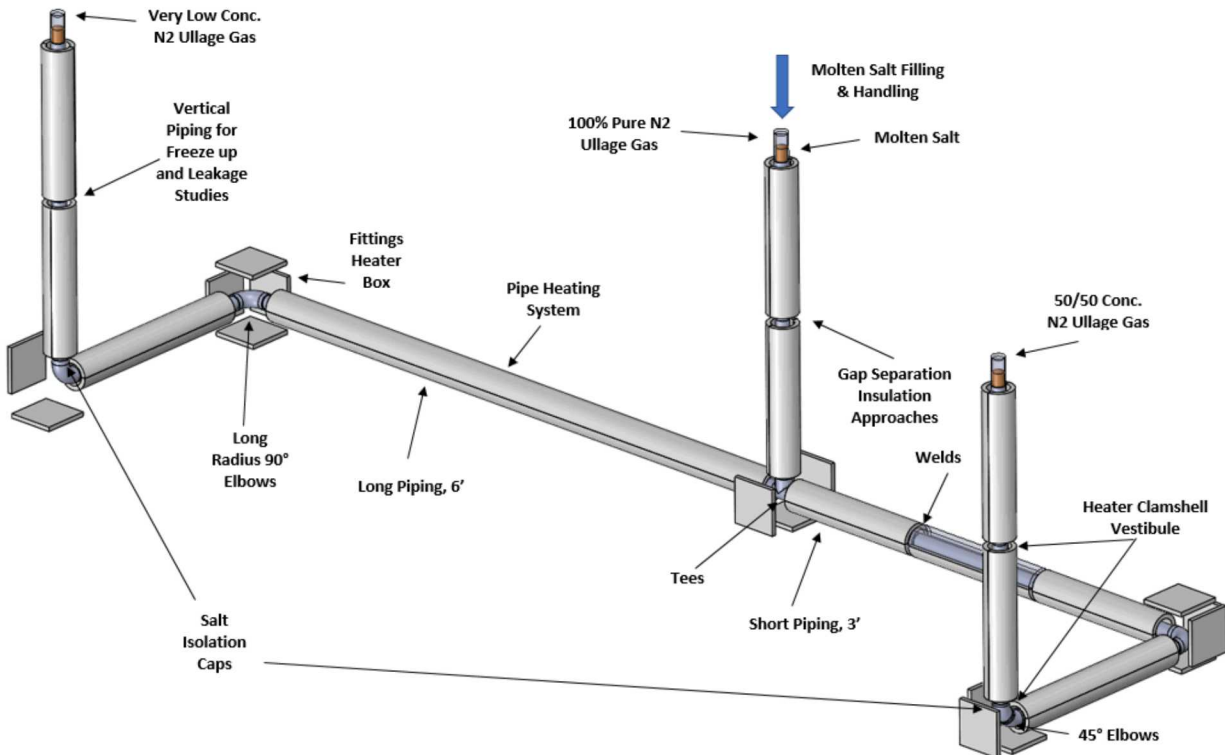

Figure 10: Phase 1B Test Setup for Thermal Transport Pipe Heating Investigations.

The table in Appendix B provides a list of system configuration tests that will be considered for the system void of salt and with salt. As shown in the table several tests will initially be performed with the piping void of salt to characterize pipe heating, expansion, weld strength and material thermal ramp rates. These assessments will provide detailed information pertaining to piping material and welds thermal mechanical strength and degradation with respect to thermal ramp rates and continuous high-temperature operation. This work will investigate four high-temperature Ni-based alloys (Haynes 230, Inconel 617), considered for use in the hot leg, with SS347H or SS 304H used in the cold leg and SS316L or SS304H in the ullage gas equalizer piping. Thermal expansion, with radiation gap spacing variability, and corrosion of the piping will also be investigated with respect to the tests considered, where pre and post-test SEM and weight-loss measurements will be conducted. Pre-conditioning analysis of the clamshell and fitting box heating systems will also be considered both pre- and post-test to evaluate reduction in the geometry. The gap spacing between clamshells, along the 3ft lengths will also be evaluated with different insulation materials and packing to determine approaches that mitigate large temperature gradients between piping and heating segments.

Additionally, with the system containing molten salt, the team will investigate contingency scenarios with the test stand where we will consider: 1. Partial and complete freeze-up of the salt within the piping, based on a line or valve failure, with the ability to recover and 2. Leak scenario to assess hazard mitigation, containment and recovery. Analysis could also be performed on the interface of two pipe preheating systems such as heat trace and CF heaters to simulate hot and cold piping leg connections.

Through the work with the proposed phase 1B investigation test bed, the team has developed a 1.3.2.2 technical milestone to de-risk challenges related to the thermal transport system. Here, six milestone metrics have been developed, where the team plans to characterize material/component performance based on down-selected piping materials, valves and weld-

types, which includes mechanical strength thermal gradients and freeze recovery. Research will also be addressing salt purity under varying nitrogen purity cover gas levels, as well as thermal-mechanical performance of the ceramic fiber heating system, with and without molten salt.

Milestone Summary Table						
Recipient	NREL					
Project title:	Liquid Pathway to SunShot					
Milestone Number	Milestone Title	Description	Metric	Success Value	Assessment Tool	Metric Justification
Unique number	Brief title of milestone	Details describing the milestone and associated methodology	Generally a quantifiable term which measures success	Metric value needed for success to be achieved	Tool indicating the confidence of success. Note this is not the measurement or modeling device. Examples include statistical formalisms, Standard codes, expert review, redundancy verifications	States why the specific success value, the assessment tool, and / or the form of the metric itself is selected. Indicate why accomplishment of the milestone is valuable
M (ST-1.3.2.2)	Thermal transport system heating validation testing report	Documentation of design of heating procedures for the transport system during primary nominal operational modes. Assessment of ability to heat elbows, straight lengths of piping of varying lengths and valves, with and without a salt HTF.	Material strength, quantification of physical deformation during heating and material mass loss.	Documentation for operating conditions	Design review by Thermal Transport Tech Team	Metric based on Risk Registry Concerns
		Assessment of ceramic fiber heater conditioning of varying geometries for straight piping lengths, fitting and valves. This assessment includes characterization and solution approaches for maintaining sufficient radiation gap spacings between the piping/fittings/valves with radiant heating system.	Heater deformation amount and rate based on thermal ramp rates. Heater gap spacing variation.	Ability to maintaining ceramic radiation gap spacing within 1-1.25 in.	Geometrical and mechanical measurements with high-temperature strain gauges.	Operating information required for system design calculations.
		Ability to maintain thermal and electrical continuity between ceramic fiber heating systems with high-temperature heat trace.	Thermal gradient quantification between piping/fittings with ceramic fiber heaters and high-temperature heat trace.	Minimize thermal gradients to less than 25°C	In-Situ piping and heater temperature measurements.	Requirement to reduce mechanical thermal stress, creep and fatigue for transport piping, fittings and valving.
		Assessment of ability to recover from salt leak event.	Full assessment of piping, any associated welds and impact to heaters. Duration of time to repair system.	Minimize recovery duration to match current nitrate salt systems.	Design review by Thermal Transport Tech Team	Operating information required for system design calculations
		Characterization of strength pertaining to welds and material types after thermal cycling and high-temperature heat soaking, with molten salt.	Mechanical strength	Documentation for operating conditions	Mechanical measurements with in-situ high-temperature strain gauges.	Operating information required for system design calculations.
Assessment of ability to recover from salt freeze events.	Piping permanent strain	assessment of maximum permanent strain and piping ID deformation.	Strain gauge measurements during experiments	Assessment and metrics based freeze-thaw recovery research used in molten salt applications to ensure piping integrity after a freeze event [Pacheco & Dunkin, 1996]		

Table 3: Phase 1B Thermal Transport 1.3.2.2 Milestone

Additionally, with the work performed with the Phase 1B test bed, assessment has been made to the risk registry where the team has provided de-risk goal values pertaining to several areas of the thermal transport system where reductions are anticipated. Table 4 provides the risk registry pertaining to the thermal transport system and forecast risk reductions, with respective justification in the right column. The test bed will enable researchers to reduce these risks through rapid construction and evaluation to help with guidelines primarily pertaining to pipe heating, labor costs and insulation, among others.

**Sandia National Laboratories
Gen 3 Topic 1 CSP Liquid-Pathway to SunShot
Pipe Preheating System Comparison Report**



Legend		9/16/2018 Armijo				4/2/2019 (Projection with Additional Phase 1B Pipe Heating Work) Armijo & Dorsey		
Risk that decreased								
Aspect	Failure Mode	Probability (0.0-1.0)	Impact (0-5)	Risk score	Notes	Probability (0.0-1.0)	Impact (0-5)	Risk score
Valves	Chemically incompatible w/salt	0.8	5	4.0		0.7	5	3.5
P sensors	Chemically incompatible w/salt	0.8	5	4.0	Sporian P sen	0.8	5	4.0
Corrosion sensors	Chemically incompatible w/salt	0.6	5	3.0		0.6	5	3.0
Flowmeters	Chemically incompatible w/salt	0.8	5	4.0	Coriolis mete	0.8	5	4.0
Joints/Welds	Chemically incompatible w/salt	0.8	4	3.2	SNRL data loc	0.7	4	2.8
Pipes	Chemically incompatible w/salt	0.8	4	3.2		0.8	4	3.2
Insulation	Inadequate Thermal Gradient	0.6	5	3.0		0.2	5	1.0
Insulation	Too Expensive (Labor)	0.6	5	3.0	Repairing an	0.4	5	2.0
T, P sensors	Mechanically Unstable	0.6	4	2.4		0.6	4	2.4
T, P sensors	Poor Precision	0.6	4	2.4		0.6	4	2.4
T, P sensors	Poor Accuracy	0.6	4	2.4		0.6	4	2.4
Insulation	Too Expensive (Materials)	0.4	5	2.0		0.3	5	1.5
Corrosion sensors	Poor Precision	0.6	3	1.8		0.6	3	1.8
Corrosion sensors	Poor Accuracy	0.6	3	1.8		0.6	3	1.8
Corrosion sensors	Availability	0.6	3	1.8		0.6	3	1.8
Insulation	Chemically incompatible w/salt	0.8	2	1.6	Salt is definit	0.6	2	1.2
Heat Trace	Control & Precision Issues	0.4	4	1.6		0.3	4	1.2
Joints/Welds	Availability	0.4	3	1.2		0.3	3	0.9
Pipes	Layout Design Limitations	0.4	3	1.2		0.4	3	1.2
Pipes	Flow Containment	0.4	3	1.2		0.4	3	1.2
Pipes	Availability	0.4	3	1.2		0.4	3	1.2
Heat Trace	Thermal-Mechanical Limitations	0.4	3	1.2		0.2	3	0.6
Heat Trace	Too Expensive (Materials)	0.4	3	1.2		0.4	3	1.2
Heat Trace	Too Expensive (Labor)	0.4	3	1.2		0.1	3	0.3
Heat Trace	Compatibility with Flow Components	0.4	3	1.2		0.1	3	0.3
Heat Trace	Compatibility with Electrical Components (e.g. Impedance Heating Systems)	0.4	3	1.2		0.1	3	0.3
Valves	Mechanically Unstable	0.4	3	1.2		0.3	3	0.9
Valves	Too Expensive (Materials)	0.4	3	1.2		0.4	3	1.2
Valves	Too Expensive (Labor)	0.4	3	1.2		0.4	3	1.2
T, P sensors	Availability	0.4	3	1.2		0.4	3	1.2
Corrosion sensors	Too Expensive (Materials)	0.4	3	1.2		0.4	3	1.2
Flowmeters	Mechanically Unstable	0.4	3	1.2		0.4	3	1.2
Flowmeters	Poor Precision	0.4	3	1.2		0.4	3	1.2
Flowmeters	Poor Accuracy	0.4	3	1.2		0.4	3	1.2
T, P sensors	Too Expensive (Materials)	0.6	2	1.2		0.6	2	1.2
Pipes	Too Expensive (Materials)	0.4	2	0.8		0.3	2	0.6
Corrosion sensors	Mechanically Unstable	0.4	2	0.8		0.4	2	0.8
Corrosion sensors	Too Expensive (Labor)	0.4	2	0.8		0.4	2	0.8
Flowmeters	Too Expensive (Materials)	0.4	2	0.8		0.4	2	0.8
Flowmeters	Availability	0.4	2	0.8		0.4	2	0.8
Pipes	Thermal-Mechanical Expansion Limitat	0.2	3	0.6		0.2	3	0.6
Joints/Welds	Mechanically Unstable	0.2	2	0.4		0.2	2	0.4
Joints/Welds	Too Expensive (Labor)	0.2	2	0.4		0.15	2	0.3
Pipes	Too Expensive (Labor)	0.2	2	0.4		0.2	2	0.4
Valves	Availability	0.2	2	0.4		0.2	2	0.4
T, P sensors	Too Expensive (Labor)	0.2	2	0.4		0.2	2	0.4
Flowmeters	Too Expensive (Labor)	0.2	2	0.4		0.2	2	0.4
Insulation	Mechanically Unstable	0.2	1	0.2	We are assur	0.2	1	0.2
Joints/Welds	Too Expensive (Materials)	0.2	1	0.2		0.15	1	0.2
Galvanic corrosion/protection		0.6	4	2.4		0.6	4	2.4

Table 4: Thermal Transport Risk Registry Forecast Based on Phase 1B Proposed Work

To facilitate Phase 1B work, the budget within Table 4 provides the breakdown of costs, primarily related to labor and contracts. Additionally, supply costs primarily pertain to the static molten salt test bed heaters, piping, instrumentation, and other components needed for the thermal transport heating investigation.

Budget Categories per SF-424a	BP 1B
a. Labor	\$700,393
b. Fringe Benefits	\$0
c. Travel	\$15,000
d. Equipment	\$0
e. Supplies	\$267,717
f. Contractual	\$540,366
g. Construction	\$0
h. Other	\$0
i. Total Direct Charges	\$1,523,476

Table 4: Phase 1B SNL Budget Breakdown

CONCLUSION

The chloride-salt blend planned for use in the Gen 3 Liquid Pathway project has a higher freeze point of 400 °C as compared to nitrate salts; therefore, the salt transport piping system is required to be pre-heated to a minimum of 450 °C. The cold salt fluid will be maintained at 500 °C and pumped to the Solar Power Tower receiver located on Level 220 where the salt will be heated to 730-740 °C through a solar receiver. This salt will flow back to the hot tank at ground level where it will be stored until used to heat supercritical CO₂ through a heat exchanger. The pipe preheating system must be able to preheat piping to a minimum of 450 °C and withstand maximum exposure temperatures of 740 °C on the molten salt hot piping system. Based on the market availability research conducted, it is believed there is only one system, the ceramic fiber heater, that can be exposed to 740 °C hot salt temperatures and not reduce the service life of the pipe preheating system. Two other systems are viable for other portions of piping system, as listed in the following table.

Pipe Preheating Method	Manufacturer	Max. Operating Temp.	Max. Exposure Temp.	Proposed Pipe Pre-Heating System	Notes
Ceramic Fiber Heater	Thermcraft Inc., Watlow Inc., DS Fibertech Co.	1200 °C	1200 °C	Molten Salt Hot, Molten Salt Cold, Ullage Gas Equalizer	Meets high temperature design conditions. High initial Cost, but very low installation cost
Heat Tape	Brisk Heat	760 °C	760 °C	None	Minimum service life at high temperature. Not reliable for long term use in the CSP Industry.
Mineral Insulated (MI) Cable	Chromalox, Raychem or Trasor	482 °C	593 °C	Molten Salt Cold, Ullage Gas Equalizer	Only viable for cold salt and ullage gas equalizer piping.

Table 5: Viable Pipe Preheating System Options

There is a significant difference between the MI cable and ceramic fiber heater installation requirements. The MI cable requires a high installation labor effort. To review, a 2-dimensional serpentine pattern is formed with the MI cable over a jig then the serpentine cable is placed over the pipe to bend into a 3-dimensional pattern and attached with stainless steel wire to the pipe. Multiple cables are then attached to the pipe one at a time, this process is very labor and time intensive due to overlapping wires (See previous Figure 7 & 8). Once all the cables are attached, then a layer of stainless steel foil 0.003-inches thick is placed over the MI cable and attached with stainless steel wire followed by a 1-inch thick layer of ceramic blanket is wrapped around the foil to protect the expanded perlite insulation which is applied in 2 – 2 inch layers with offsetting seams/layer joints and to allow for thermal growth (Figure 9). MI cable labor effort is significantly higher compared to placing two semi-cylindrical pipe heater sections over the pipe and securing in place with two ½” wide stainless steel bands tighten over the heater vestibule (Figure 1 & 2), followed by wrapping ceramic blanket insulation, 4-inches thick, around the CF heater followed by the metal weatherproof jacket.

Previous MI cable and insulation installation costs for the SNL MSTL Project were unarchived and compared to the estimated costs for the Ceramic Fiber heater including insulation. The results are summarized in the following table:

CF Heater vs. MI Cable Installed Cost Comparison					
Pipe Heating System	Heater Initial Cost	Heater Installation Cost	Insulation Installation Cost	Contractor Markup	Total Installed Cost (Full Contractor Markup)
Ceramic Fiber	\$400-\$700 / ft.	\$75 / ft.	\$190 / ft.	1.3	\$865 - \$1255 / ft.
MI Cable	\$150 / ft.	\$170 / ft.	\$388 / ft.	1.3	\$920 / ft.

Table 6: CF Heater vs. MI Cable Installed Cost Comparison

The variance in the CF heater initial cost is due to manufacturer’s concerns over the quantity of unknowns in items such as elbows. Thermcraft is capable of manufacturing the CF heater elbows, but they cost more than a straight section. There are approximately 700 ft. of 2-1/2” molten salt pipe and 350 ft. of 1-inch ullage gas equalizer pipe anticipated in the project. As the design becomes better defined, the CF heater cost variance will be reassessed. At this time, it is not known what the valve and mass flow meter configuration and preheat requirements will be. This will also have an impact on the cost of the preheat system. From an operational cost and maintenance viewpoint, it is believed the pipe preheating system should be the same for all piping systems. The CF heater is the only known reliable system which can be used to meet all requirements of the Gen 3 Liquid Pathway project. NREL has over 5 years of operational time using CF heaters to heat pipe and vessels to 500-1000 °C. MI cable manufacturers publish claims in their literature to be able to heat to 1000 °C, but this is for very small bench top applications and not for industrial, large scale application. Unless additional information is uncovered during the Phase I and Phase II design period, it is recommended using the ceramic fiber heater throughout the Gen 3 Liquid Pathway project. Onsite testing (no salt fluid followed by static salt filled tests) is recommended on small sections of similar pipe size in an outdoor environment such as at SNL MSTL utilizing their existing LabView control system along with the Emersion Tyco heat trace control system before final system selection.

The CF heaters placed on 2 1/2-inch pipe with 4-inches of ceramic blanket wrap have an equivalent 14-inch diameter. Appendix A has images of the current Gen 3 Liquid-Pathway piping design within the Solar Power Tower. The images in Appendix A reflect the expansion loops, pipe guides and pipe supports as currently designed using Caesar II finite element analysis modelling. The steel framing design for the pipe supports and pipe guides is in progress. The intent of providing these images in Appendix A is to demonstrate the use of CF heaters in the Solar Power Tower including expansion loop design is viable solution for preheating and high temperature exposure.

APPENDIX A

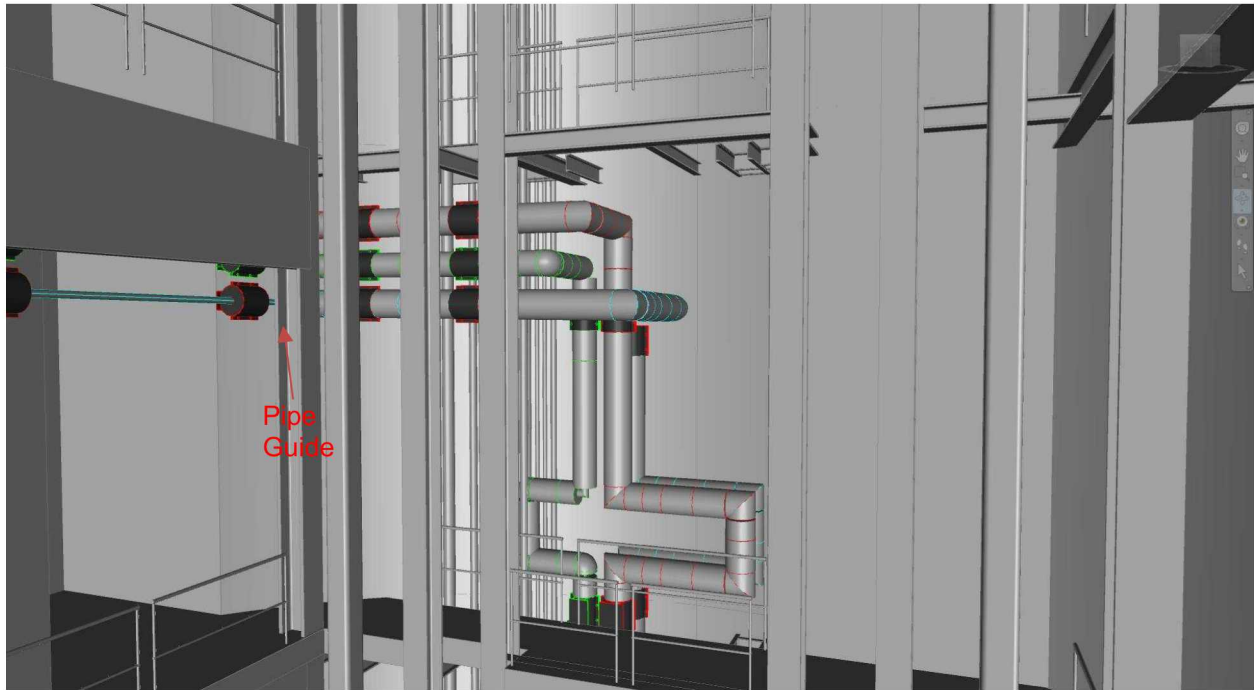

Level 200 Insulated Piping with CF Heater: Ullage Gas Equalizer, Molten Salt Hot and Cold Piping being routed from Solar Tower piping shaft floor below Solar Receiver.

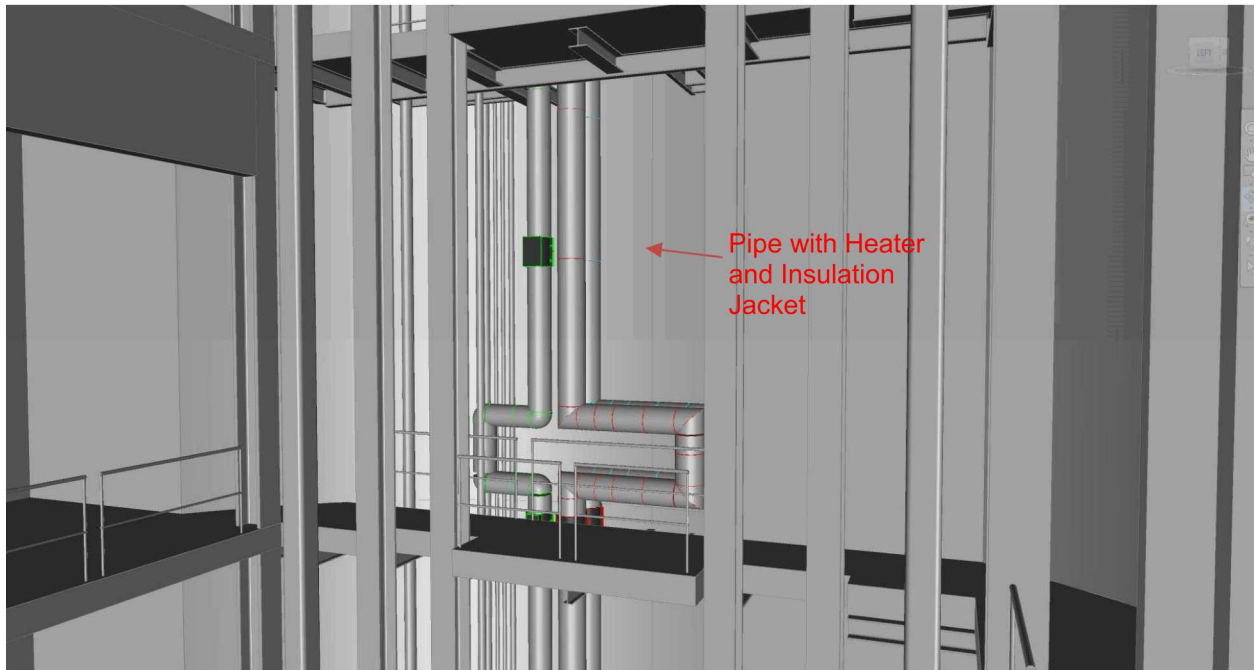

Level 180 Insulated Piping with CF Heater: Ullage Gas Equalizer, Molten Salt Hot and Cold Piping Expansion Loop.

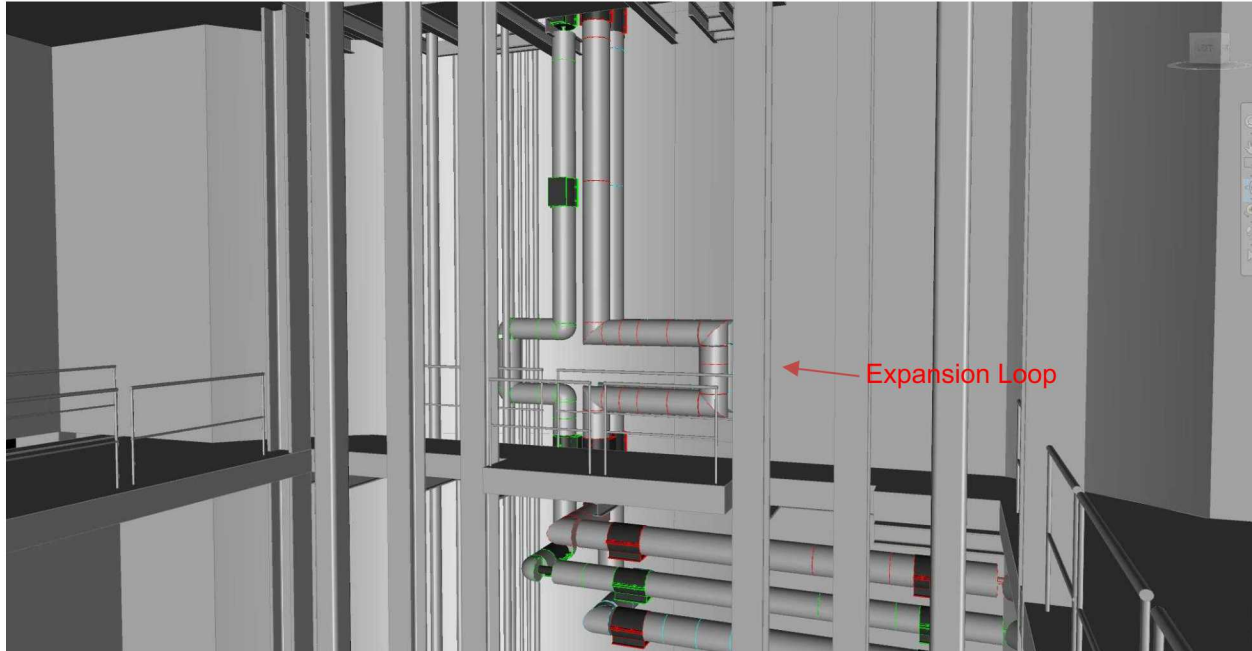

Level 140-160 Insulated Piping with CF Heater: Ullage Gas Equalizer, Molten Salt Hot and Cold Piping Expansion Loop and piping route to south Solar Tower exterior wall.

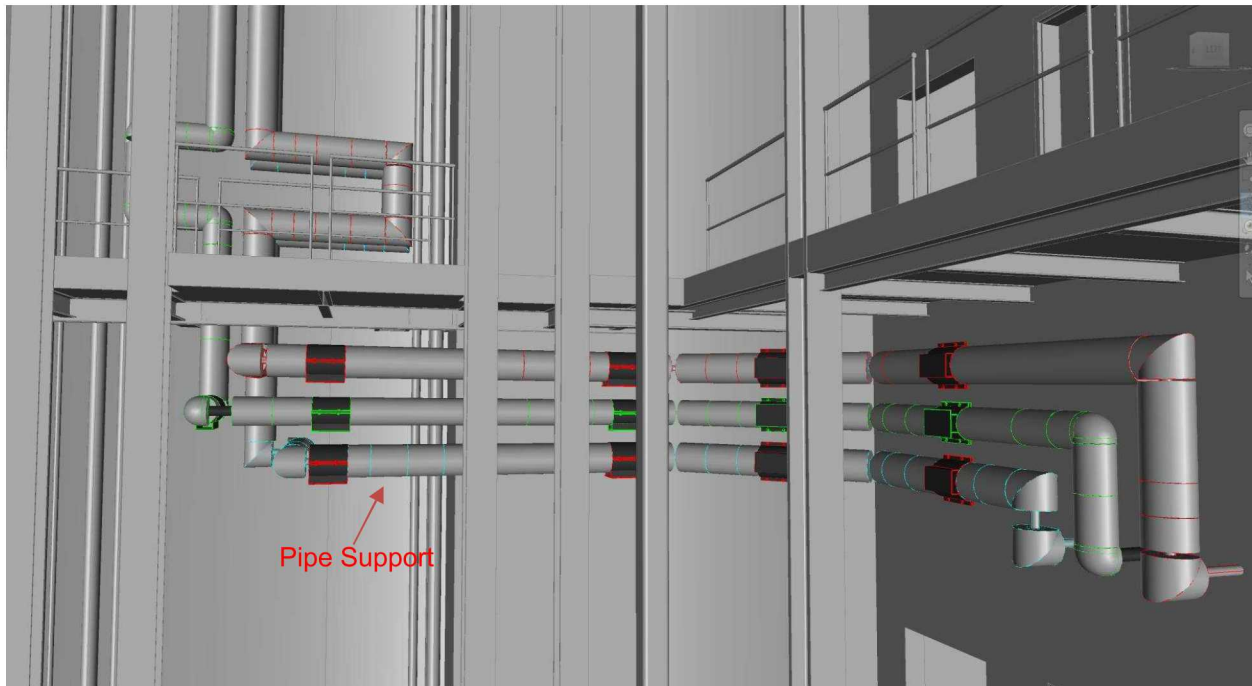

Level 140 Insulated Piping with CF Heater: Ullage Gas Equalizer, Molten Salt Hot and Cold Piping Expansion Loop and piping route to south Solar Tower exterior wall.

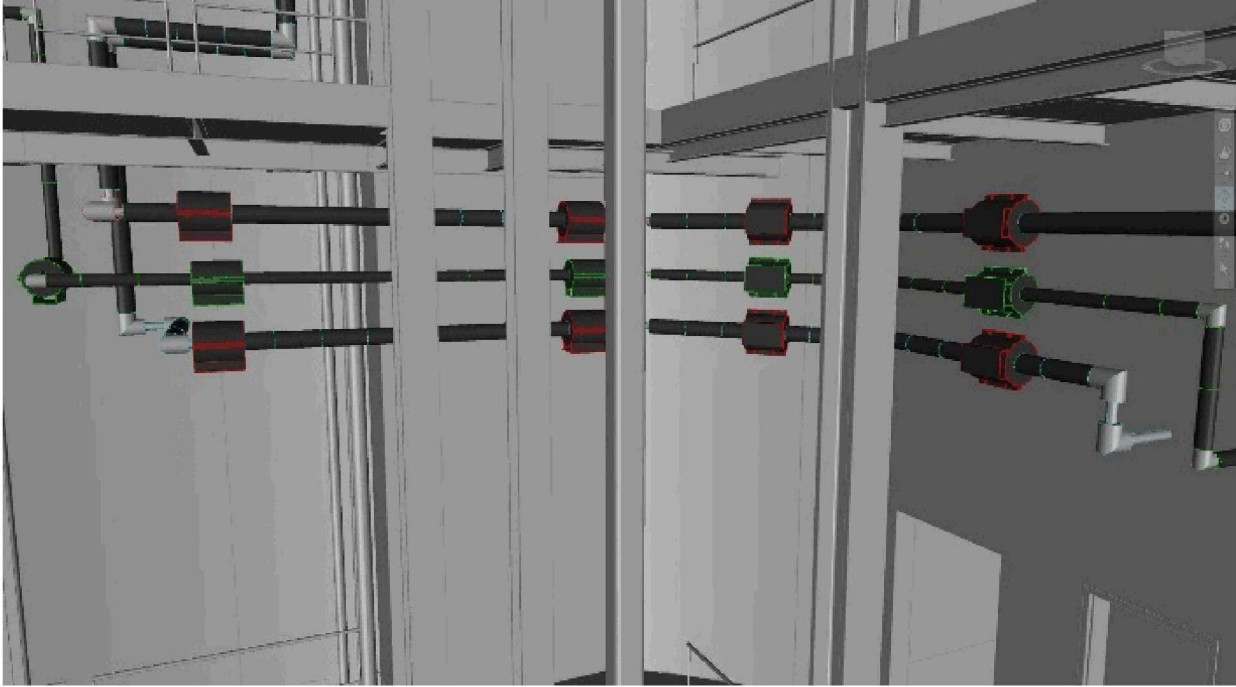

Level 140 Piping Entering Tower: Ullage Gas Equalizer, Molten Salt Hot and Cold Piping with Guides and Supports.

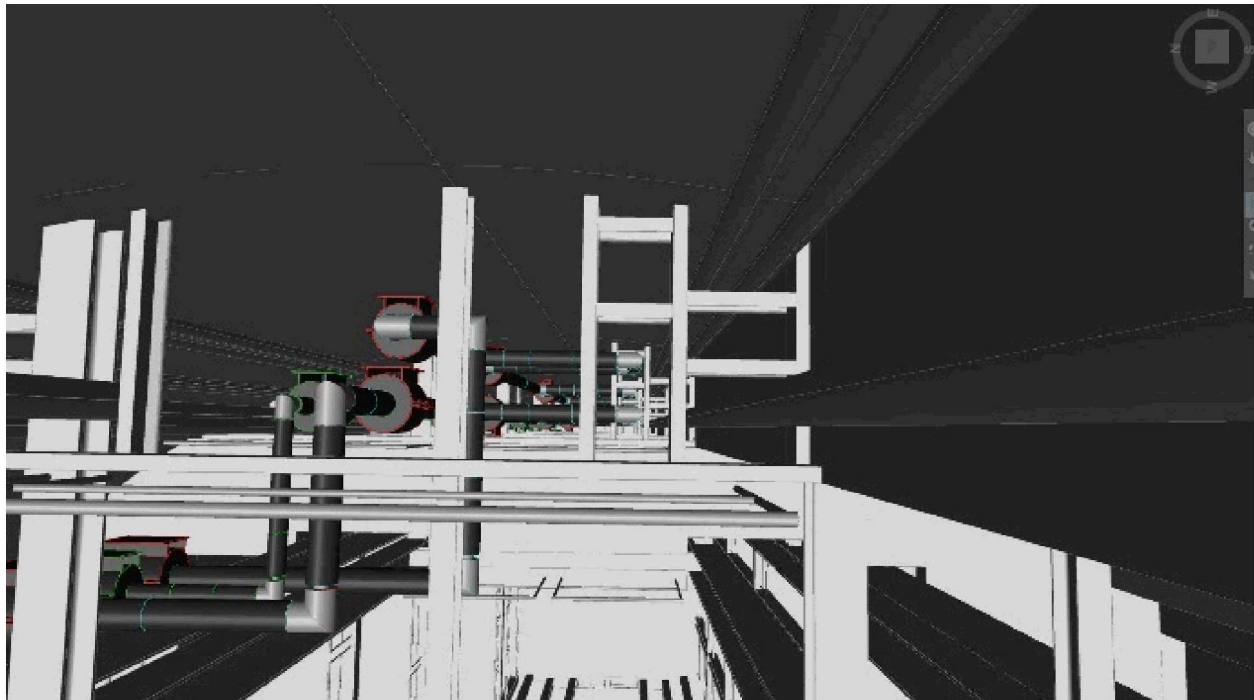

Solar Tower Piping Shaft View Looking Down: Ullage Gas Equalizer, Molten Salt Hot and Cold Piping with CF Heaters, Guides and Supports.

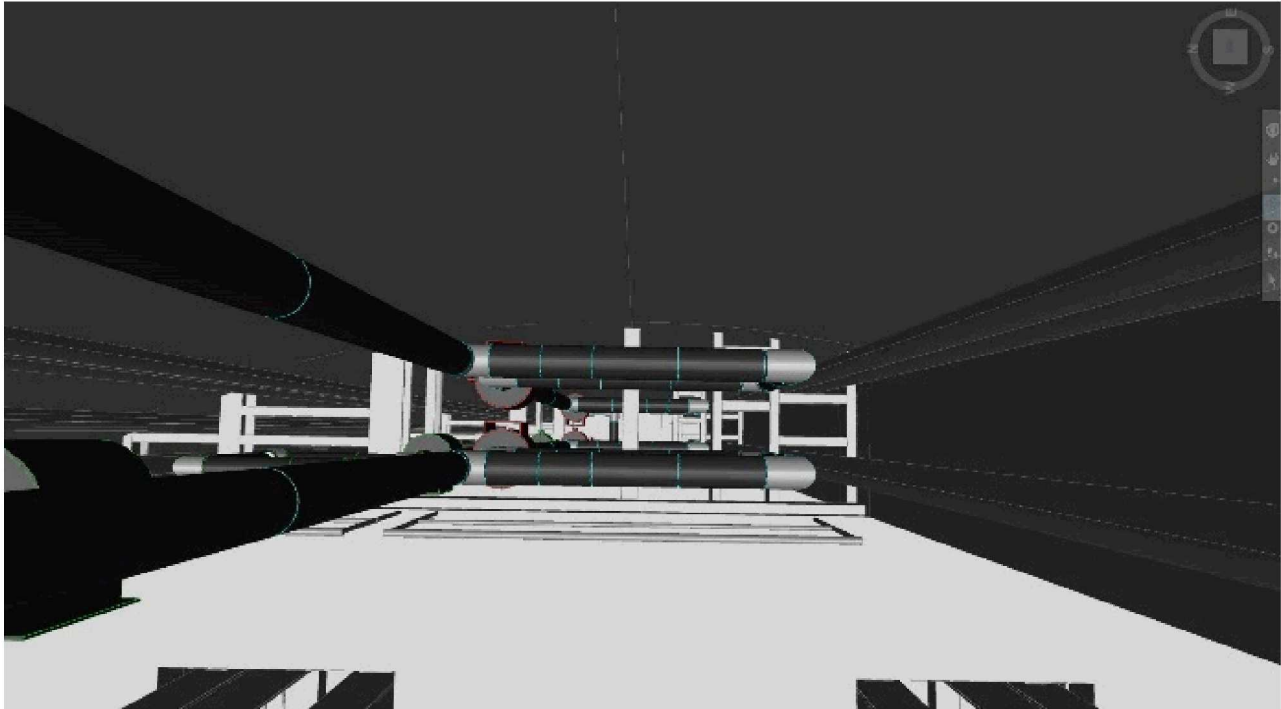

Solar Tower Piping Shaft View Looking Down: Ullage Gas Equalizer, Molten Salt Hot and Cold Piping with Insulation, CF Heaters, Guides and Supports.

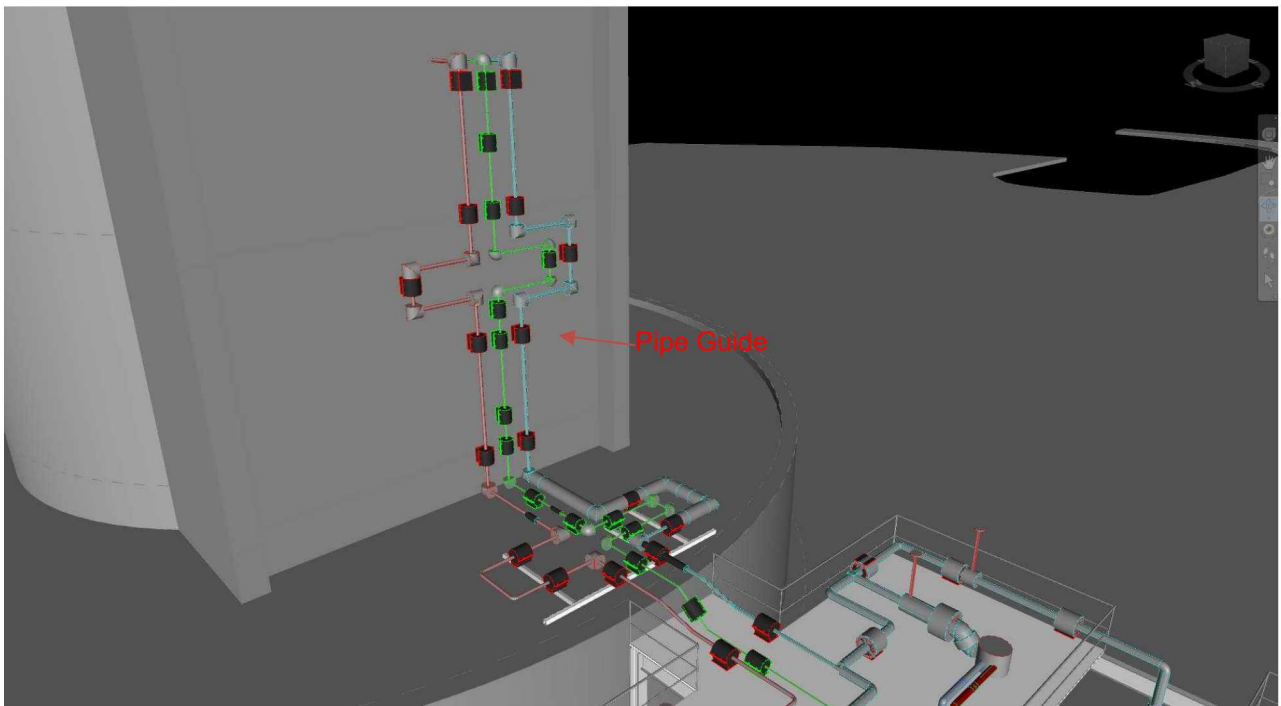

Level 120-140 Insulated Piping with CF Heater: Ullage Gas Equalizer, Molten Salt Hot and Cold Piping Expansion Loop and piping routed out south Solar Tower exterior wall to salt storage tanks.

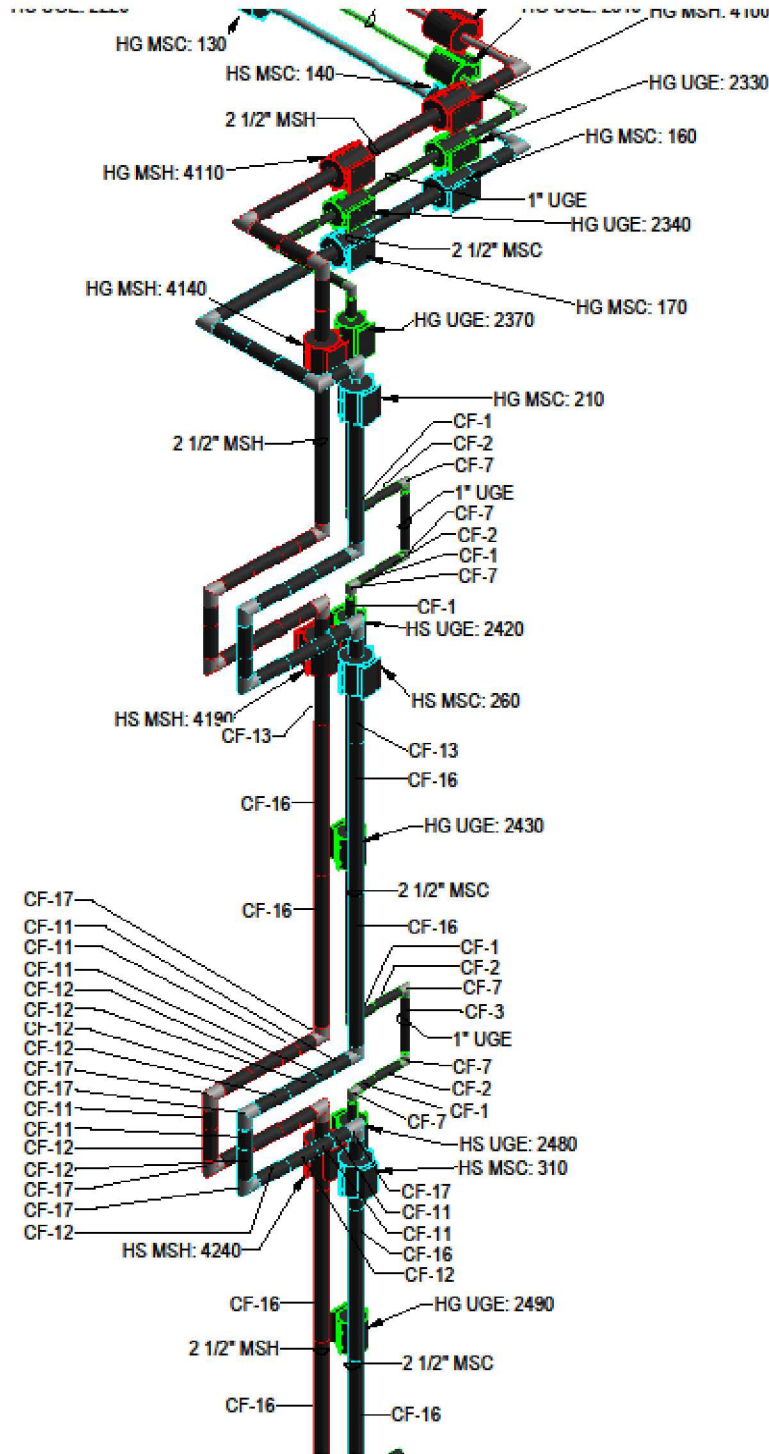

Piping Isometric with Ceramic Heaters Identified on the Molten Salt Hot & Cold Piping and Ullage Gas Equalizer Pipe.

APPENDIX B

Test Number	Salt/No Salt	Thermal System Configuration	Heater Configuration	Pipe Configuration	Piping Material
1	No Salt	Thermal Ramping - Low Ramping	Clamshells and fitting boxes	CF Heating – 2-6ft legs, 2-2ft legs, 3-3ft legs	Haynes 230
2	No Salt	Thermal Ramping - Medium Ramping	Clamshells and fitting boxes	CF Heating – 2-6ft legs, 2-2ft legs, 3-3ft legs	Haynes 230
3	No Salt	Thermal Ramping - High Ramping	Clamshells and fitting boxes	CF Heating – 2-6ft legs, 2-2ft legs, 3-3ft legs	Haynes 230
4	No Salt	Thermal Ramping - Low Ramping	Clamshells and fitting boxes	CF Heating – 2-6ft legs, 2-2ft legs, 3-3ft legs	Inconel 617
5	No Salt	Thermal Ramping - Medium Ramping	Clamshells and fitting boxes	CF Heating – 2-6ft legs, 2-2ft legs, 3-3ft legs	Inconel 617
6	No Salt	Thermal Ramping - High Ramping	Clamshells and fitting boxes	CF Heating – 2-6ft legs, 2-2ft legs, 3-3ft legs	Inconel 617
7	No Salt	Thermal Ramping - Low Ramping	Clamshells and fitting boxes	CF Heating – 2-6ft legs, 2-2ft legs, 3-3ft legs	740H
8	No Salt	Thermal Ramping - Medium Ramping	Clamshells and fitting boxes	CF Heating – 2-6ft legs, 2-2ft legs, 3-3ft legs	740H
9	No Salt	Thermal Ramping - High Ramping	Clamshells and fitting boxes	CF Heating – 2-6ft legs, 2-2ft legs, 3-3ft legs	740H
10	No Salt	Thermal Ramping - Low Ramping	Clamshells and fitting boxes	CF Heating – 2-6ft legs, 2-2ft legs, 3-3ft legs	304H
11	No Salt	Thermal Ramping - Medium Ramping	Clamshells and fitting boxes	CF Heating – 2-6ft legs, 2-2ft legs, 3-3ft legs	304H
12	No Salt	Thermal Ramping - High Ramping	Clamshells and fitting boxes	CF Heating – 2-6ft legs, 2-2ft legs, 3-3ft legs	304H
13	No Salt	Thermal Ramping - Low Ramping	Clamshells and fitting boxes	CF Heating – 2-6ft legs, 2-2ft legs, 3-3ft legs	347H
14	No Salt	Thermal Ramping - Medium Ramping	Clamshells and fitting boxes	CF Heating – 2-6ft legs, 2-2ft legs, 3-3ft legs	347H

15	No Salt	Thermal Ramping - High Ramping	Clamshells and fitting boxes	CF Heating – 2-6ft legs, 2-2ft legs,3- 3ft legs	347H
16	No Salt, w/ N ₂ Gas	Thermal Ramping - Low Ramping	Clamshells and fitting boxes	CF Heating – 2-6ft legs, 2-2ft legs,3- 3ft legs	316L
17	No Salt, w/ N ₂ Gas	Thermal Ramping - Medium Ramping	Clamshells and fitting boxes	CF Heating – 2-6ft legs, 2-2ft legs,3- 3ft legs	316L
18	No Salt, w/ N ₂ Gas	Thermal Ramping - High Ramping	Clamshells and fitting boxes	CF Heating – 2-6ft legs, 2-2ft legs,3- 3ft legs	316L
19	No Salt	Continuous High- Temperature Operation - 700 °C	Clamshells and fitting boxes	CF Heating – 2-6ft legs, 2-2ft legs,3- 3ft legs	Haynes 230
20	No Salt	Continuous High- Temperature Operation - 800 °C	Clamshells and fitting boxes	CF Heating – 2-6ft legs, 2-2ft legs,3- 3ft legs	Haynes 230
21	No Salt	Continuous High- Temperature Operation - 850 °C	Clamshells and fitting boxes	CF Heating – 2-6ft legs, 2-2ft legs,3- 3ft legs	Inconel 617
22	No Salt	Continuous High- Temperature Operation - 700 °C	Clamshells and fitting boxes	CF Heating – 2-6ft legs, 2-2ft legs,3- 3ft legs	Inconel 617
23	No Salt	Continuous High- Temperature Operation - 800 °C	Clamshells and fitting boxes	CF Heating – 2-6ft legs, 2-2ft legs,3- 3ft legs	740H
24	No Salt	Continuous High- Temperature Operation - 850 °C	Clamshells and fitting boxes	CF Heating – 2-6ft legs, 2-2ft legs,3- 3ft legs	740H
25	No Salt	Continuous High- Temperature Operation - 700 °C	Clamshells and fitting boxes	CF Heating – 2-6ft legs, 2-2ft legs,3- 3ft legs	304H
26	No Salt	Continuous High- Temperature Operation - 800 °C	Clamshells and fitting boxes	CF Heating – 2-6ft legs, 2-2ft legs,3- 3ft legs	304H
27	No Salt	Continuous High- Temperature Operation - 850 °C	Clamshells and fitting boxes	CF Heating – 2-6ft legs, 2-2ft legs,3- 3ft legs	304H
28	No Salt	Continuous High- Temperature Operation - 700 °C	Clamshells and fitting boxes	CF Heating – 2-6ft legs, 2-2ft legs,3- 3ft legs	304H
29	No Salt	Continuous High- Temperature Operation - 800 °C	Clamshells and fitting boxes	CF Heating – 2-6ft legs, 2-2ft legs,3- 3ft legs	Haynes 230
30	No Salt	Continuous High- Temperature Operation - 850 °C	Clamshells and fitting boxes	CF Heating – 2-6ft legs, 2-2ft legs,3- 3ft legs	Haynes 230

31	Salt	Thermal Ramping - Low Ramping	Clamshells and fitting boxes	CF Heating – 2-6ft legs, 2-2ft legs,3- 3ft legs	Haynes 230
32	Salt	Thermal Ramping - Medium Ramping	Clamshells and fitting boxes	CF Heating – 2-6ft legs, 2-2ft legs,3- 3ft legs	Inconel 617
33	Salt	Thermal Ramping - Low Ramping	Clamshells and fitting boxes	CF Heating – 2-6ft legs, 2-2ft legs,3- 3ft legs	Inconel 617
34	Salt	Thermal Ramping - Low Ramping	Clamshells and fitting boxes	CF Heating – 2-6ft legs, 2-2ft legs,3- 3ft legs	Inconel 617
35	Salt	Thermal Ramping - Medium Ramping	Clamshells and fitting boxes	CF Heating – 2-6ft legs, 2-2ft legs,3- 3ft legs	740H
36	Salt	Thermal Ramping - Low Ramping	Clamshells and fitting boxes	CF Heating – 2-6ft legs, 2-2ft legs,3- 3ft legs	740H
37	Salt	Thermal Ramping - Low Ramping	Clamshells and fitting boxes	CF Heating – 2-6ft legs, 2-2ft legs,3- 3ft legs	740H
38	Salt	Thermal Ramping - Medium Ramping	Clamshells and fitting boxes	CF Heating – 2-6ft legs, 2-2ft legs,3- 3ft legs	304H
39	Salt	Thermal Ramping - Low Ramping	Clamshells and fitting boxes	CF Heating – 2-6ft legs, 2-2ft legs,3- 3ft legs	304H
40	Salt	Thermal Ramping - Low Ramping	Clamshells and fitting boxes	CF Heating – 2-6ft legs, 2-2ft legs,3- 3ft legs	304H
41	Salt	Thermal Ramping - Medium Ramping	Clamshells and fitting boxes	CF Heating – 2-6ft legs, 2-2ft legs,3- 3ft legs	347H
42	Salt	Thermal Ramping - Low Ramping	Clamshells and fitting boxes	CF Heating – 2-6ft legs, 2-2ft legs,3- 3ft legs	347H
43	Salt	Thermal Ramping - Low Ramping	Clamshells and fitting boxes	CF Heating – 2-6ft legs, 2-2ft legs,3- 3ft legs	347H
44	Salt	Continuous High- Temperature Operation - 700 °C	Clamshells and fitting boxes	CF Heating – 2-6ft legs, 2-2ft legs,3- 3ft legs	Haynes 230
45	Salt	Continuous High- Temperature Operation - 800 °C	Clamshells and fitting boxes	CF Heating – 2-6ft legs, 2-2ft legs,3- 3ft legs	Haynes 230
46	Salt	Continuous High- Temperature Operation - 850 °C	Clamshells and fitting boxes	CF Heating – 2-6ft legs, 2-2ft legs,3- 3ft legs	Haynes 230

47	Salt	Continuous High-Temperature Operation - 700 °C	Clamshells and fitting boxes	CF Heating – 2-6ft legs, 2-2ft legs, 3-3ft legs	Inconel 617
48	Salt	Continuous High-Temperature Operation - 800 °C	Clamshells and fitting boxes	CF Heating – 2-6ft legs, 2-2ft legs, 3-3ft legs	Inconel 617
49	Salt	Continuous High-Temperature Operation - 850 °C	Clamshells and fitting boxes	CF Heating – 2-6ft legs, 2-2ft legs, 3-3ft legs	Inconel 617
50	Salt	Continuous High-Temperature Operation - 700 °C	Clamshells and fitting boxes	CF Heating – 2-6ft legs, 2-2ft legs, 3-3ft legs	740H
51	Salt	Continuous High-Temperature Operation - 800 °C	Clamshells and fitting boxes	CF Heating – 2-6ft legs, 2-2ft legs, 3-3ft legs	740H
52	Salt	Continuous High-Temperature Operation - 850 °C	Clamshells and fitting boxes	CF Heating – 2-6ft legs, 2-2ft legs, 3-3ft legs	740H
53	Salt	Continuous High-Temperature Operation - 700 °C	Clamshells and fitting boxes	CF Heating – 2-6ft legs, 2-2ft legs, 3-3ft legs	304H
54	Salt	Continuous High-Temperature Operation - 800 °C	Clamshells and fitting boxes	CF Heating – 2-6ft legs, 2-2ft legs, 3-3ft legs	304H
55	Salt	Continuous High-Temperature Operation - 850 °C	Clamshells and fitting boxes	CF Heating – 2-6ft legs, 2-2ft legs, 3-3ft legs	304H
56	Salt	Continuous High-Temperature Operation - 700 °C	Clamshells and fitting boxes	CF Heating – 2-6ft legs, 2-2ft legs, 3-3ft legs	347H
57	Salt	Continuous High-Temperature Operation - 800 °C	Clamshells and fitting boxes	CF Heating – 2-6ft legs, 2-2ft legs, 3-3ft legs	347H
58	Salt	Continuous High-Temperature Operation - 850 °C	Clamshells and fitting boxes	CF Heating – 2-6ft legs, 2-2ft legs, 3-3ft legs	347H
59	Salt	Power Reduction to Freeze-up and Freeze Recovery	Clamshells and fitting boxes	CF Heating – 2-6ft legs, 2-2ft legs, 3-3ft legs	347H
60	Salt	Power Reduction to Freeze-up and Freeze Recovery	Clamshells and fitting boxes	CF Heating – 2-6ft legs, 2-2ft legs, 3-3ft legs	Inconel 617
61	Salt	Induced Leak, Containment, Recovery	Clamshells and fitting boxes	CF Heating – 2-6ft legs, 2-2ft legs, 3-3ft legs	347H
62	Salt	Induced Leak, Containment, Recovery	Clamshells and fitting boxes	CF Heating – 2-6ft legs, 2-2ft legs, 3-3ft legs	Inconel 617