

SANDIA REPORT

SAND2019- 2436

Printed February 2019



Sandia
National
Laboratories

Assessment of Existing Capabilities and Future Needs for Designing Networked Microgrids

Shamina Hossain-McKenzie¹, Matthew J. Reno¹, John Eddy¹, Kevin P. Schneider²

¹Sandia National Laboratories, Albuquerque, NM 87185

²Pacific Northwest National Laboratory, Seattle, WA 98109

Prepared by
Sandia National Laboratories
Albuquerque, New Mexico
87185 and Livermore,
California 94550

Issued by Sandia National Laboratories, operated for the United States Department of Energy by National Technology & Engineering Solutions of Sandia, LLC.

NOTICE: This report was prepared as an account of work sponsored by an agency of the United States Government. Neither the United States Government, nor any agency thereof, nor any of their employees, nor any of their contractors, subcontractors, or their employees, make any warranty, express or implied, or assume any legal liability or responsibility for the accuracy, completeness, or usefulness of any information, apparatus, product, or process disclosed, or represent that its use would not infringe privately owned rights. Reference herein to any specific commercial product, process, or service by trade name, trademark, manufacturer, or otherwise, does not necessarily constitute or imply its endorsement, recommendation, or favoring by the United States Government, any agency thereof, or any of their contractors or subcontractors. The views and opinions expressed herein do not necessarily state or reflect those of the United States Government, any agency thereof, or any of their contractors.

Printed in the United States of America. This report has been reproduced directly from the best available copy.

Available to DOE and DOE contractors from

U.S. Department of Energy
Office of Scientific and Technical Information
P.O. Box 62
Oak Ridge, TN 37831

Telephone: (865) 576-8401
Facsimile: (865) 576-5728
E-Mail: reports@osti.gov
Online ordering: <http://www.osti.gov/scitech>

Available to the public from

U.S. Department of Commerce
National Technical Information Service
5301 Shawnee Rd
Alexandria, VA 22312

Telephone: (800) 553-6847
Facsimile: (703) 605-6900
E-Mail: orders@ntis.gov
Online order: <https://classic.ntis.gov/help/order-methods/>



ABSTRACT

This is a review of existing microgrid design tool capabilities, such as the Microgrid Design Tool (MDT), LANL PNNL NRECA Optimal Resilience Model (LPNORM), Distributed Energy Resource-Customer Adoption Model (DER-CAM), Renewable Energy Optimization (REopt), and the Hybrid Optimization Model for Multiple Energy Resources (HOMER). Additionally, other simulation and analysis tools which may provide fundamental support will be examined. These will include GridLAB-D™, OpenDSS, and the hierarchical Engine for Large-scale Infrastructure Co-Simulation (HELICS). Their applicability to networked microgrid operations will be evaluated, and strengths and gaps of existing tools will be identified. This review will help to determine which elements of the proposed optimal design and operations (OD&D) tool should be formulated from first principles, and which elements should be integrated from past DOE investments.

ACKNOWLEDGEMENTS

The authors would like to thank the various individuals, microgrid design tool developers and/or domain experts, who helped expand our understanding of the different tools and their capabilities. The authors gratefully acknowledge Wilson Rickerson (Converge Strategies LLC), Michael Stadler (XENDEE), Russell Bent (Los Alamos National Laboratory), Guodong Liu (Oak Ridge National Laboratory), Kate Anderson (National Renewable Energy Laboratory), Harsha Nagarajan (Los Alamos National Laboratory), and Hassan Hijazi (Los Alamos National Laboratory). We would also like to thank Dan Ton, DOE Office of Electricity, and the Advanced Grid Research Program for supporting this work.

CONTENTS

1. Introduction.....	7
1.1. Motivation for Networked Microgrids	7
1.2. Networked Microgrids Challenges for Design and Planning.....	8
1.3. Objectives of Networked Microgrids OD&O Tool.....	8
1.4. Requirements for Networked Microgrids OD&O Tool.....	10
2. Existing Microgrid Tools and Relevant Capabilities.....	13
2.1. Background on Microgrid Design	13
2.2. Description of Existing Microgrid Design Tools	13
2.2.1. Microgrid Design Toolkit (MDT).....	13
2.2.2. Distributed Energy Resources – Customer Adoption Model (DER-CAM).....	14
2.2.3. Remote Off-Grid Microgrids Design Support Tool (ROMDST)	16
2.2.4. Microgrid Assisted Design for Remote Areas (MADRA)	16
2.2.5. Renewable Energy Integration and Optimization (REopt)	17
2.2.6. LPNORM: LANL PNNL NRECA Optimal Resiliency Model	18
2.2.7. Comparison of Microgrid Design Tool Features	19
2.3. Description of Commercial Microgrid Design Tools	21
2.3.1. Hybrid Optimization of Multiple Energy Resources (HOMER) Pro	21
2.3.2. Xendee	21
2.3.3. ETAP Microgrid.....	22
2.3.4. Siemens SICAM Microgrid Manager	23
2.4. Description of Power System Solvers and Role in Designing Microgrids	23
2.4.1. GridLAB-D™	23
2.4.2. OpenDSS.....	24
2.4.3. Hierarchical Engine for Large-Scale Infrastructure Co-Simulation (HELICS)	25
3. Comparison of Existing Tools and Application to Network Microgrid Design.....	26
3.1. Gaps in Current Tools for Networked Microgrids and Future Needs.....	27
3.2. Mapping of External Tools to Networked Microgrid OD&O Needs	28
3.3. Addressing the Gaps: New Capabilities for Core OD&O Tool	28
4. Conclusions.....	30
5. References	31

LIST OF FIGURES

Figure 1: Example of a networked microgrid composed of four microgrids [2].	7
Figure 2: Snapshot of MDT tool interfaces [5].	14
Figure 3: Example interface and results from DER-CAM tool [6].	15
Figure 4: Snapshot of MADRA interface.....	16
Figure 5: Example results of MADRA	17
Figure 6: Visualization of REopt framework [9].	18
Figure 7: LPNORM system architecture [10].	19

LIST OF TABLES

Table 1: Comparison of Noncommercial, Research-Focused Microgrid Design Tools.....	20
Table 2: Comparison of Existing Tool Capabilities and Proposed OD&O Tool for Networked Microgrid Application	27

This page left blank

1. INTRODUCTION

Microgrids have proven to be very valuable and effective for a range of applications, from increasing the resilience of cities to ensuring critical infrastructure (e.g., hospitals and military bases) remain functional and in-service during extreme events. A novel concept to maximize the benefits of microgrids is the idea of networked microgrids. Essentially, creating a network of microgrids that can operate individually or form a microgrid cluster operating together [1]. Networked microgrids would offer various advantages, as will be detailed in the next subsection, but a critical and necessary first step is obtaining/creating effective tools to design them. Tools are needed to determine an optimal design (generation amounts, placement and selection of microgrids, network connections, and etc.), that is supported by operational constraints (stability and protection) to design optimal and functional networked microgrids. The remainder of this document will review existing microgrid design tool capabilities, what features can be leveraged for networked microgrid design, and what capabilities are needed and require further investigation.

1.1. Motivation for Networked Microgrids

Networked microgrids, clusters of geographically-close islanded microgrids that can function as a single, aggregate island, can significantly improve the reliability and resilience of the electric grid. The two main motivations and goals of networked microgrids are to:

- 1) Improve customer-level reliability and resilience during extreme event outages and
- 2) reduce utility costs during normal grid operations.

A coordinated cluster of microgrids would enable access to increased resources, extend service availability, and provide attractive flexibility. A simple example of a networked microgrid is shown in Figure 1 [2] where the individual microgrids can be coordinated through an Energy Management System (EMS), Distribution Management System (DMS), or central microgrid controller.

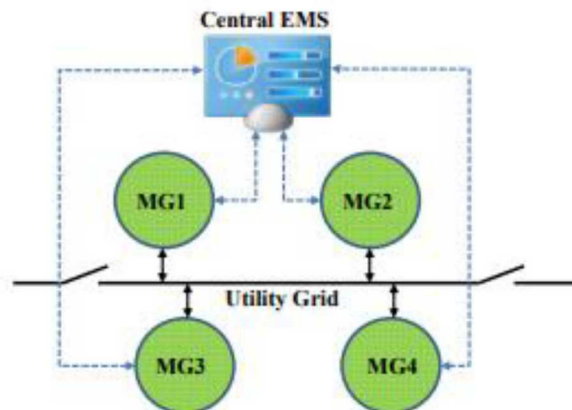
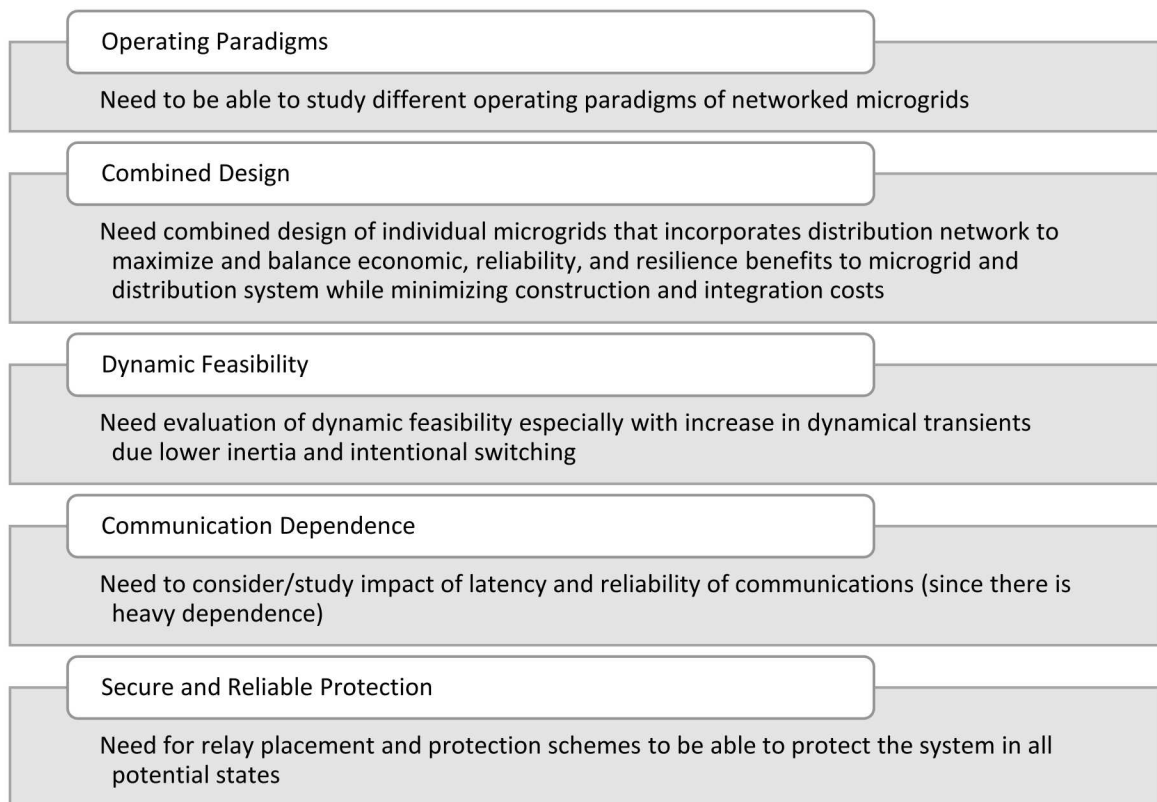

Figure 1: Example of a networked microgrid composed of four microgrids [2].

Increased flexibility, economics, resilience, and reliability are the prominent advantages of enabling networked microgrids. These benefits are primarily due to the increased, aggregate resources and redundancy achieved via networking. However, some of the challenges that arise for obtaining networked microgrids are the necessary tools for optimal design, suitable control paradigms, and deep understanding of impact to stability both locally and globally. In this report, we focus on the challenge of finding and/or creating suitable tools for designing optimal networked microgrids.

1.2. Networked Microgrids Challenges for Design and Planning

The main challenges for designing and planning networked microgrids can be summarized as:



These challenges will inform the analysis of the compatibility of existing microgrid tools to design networked microgrids and identify important gaps. The next two sections will dive deeper into deconstructing these challenges into the specific objectives and requirements needed for successfully designing and planning networked microgrids.

1.3. Objectives of Networked Microgrids OD&O Tool

For the designing and planning of networked microgrids, pertinent research factors include network controller development, system/network state estimation, and assessment frameworks for comparing networking strategies (at the physical layer, control layer, or both). The physical (e.g., distribution lines) and control layers are central to the development of an effective network controller; the dependencies between the layers need to be studied carefully and incorporated into the overall networked microgrid design.

Important overall factors to consider for designing and planning networked microgrids are:

1. Regulatory environment
2. Business case evaluation
3. Architecture design and use cases
4. Dynamical system interactions
5. Protection design

These factors need to be appropriately integrated into a networked microgrid optimal design and operations (OD&O) tool. Regulatory environments will inform the network configuration and control of specific networked microgrid designs. Thus, a tool should have the flexibility to explore impacts like right-of-ways and assess optimal networks that achieve desirable outcomes inside the regulatory environment. Similarly, business cases must be assessed to ensure, within the regulatory environment(s), economic advantages and disadvantages are considered.

The regulatory environment and business case evaluations can then inform the networked microgrid architecture design and use cases. Designing the architecture includes the physical and control layers as well as the information architecture; uses cases need to be developed to demonstrate how optimization and control actions can be implemented in the networked microgrid and can handle the necessary time-steps. The tool should be able to include protection design for individual and the network of microgrids [3]. Finally, the overall networked microgrid dynamic system interactions must be assessed carefully using design tool(s). From transient stability to voltage collapse, the interactions of the different microgrids in a unified network must be studied.

Furthermore, the overall functional requirements in addition to the dynamical interactions need to be studied with a networked microgrid design and planning tool. The requirement studies include [4]:

- **Evaluation of business cases of different networked microgrid configurations and impact on different grid operations and control paradigms.**
 - Performance under “normal” grid operational situations where grid operations are primarily driven by economic considerations; evaluate operation in a range of paradigms including completely independent microgrids, centrally coordinated via the distribution system operator, and distributed optimization and control.
 - This business case evaluation and optimization should account for both market and non-market settings.
- **Evaluation of system-level and customer-level reliability and system design to improve overall reliability under “normal” grid operation.**
- **Evaluation of resilience of networked microgrid systems and connected distribution network under “extreme” grid operational situations (when component failures are extensive).**
- **Ability to do aggregate design on individual microgrids and distribution network integration with consideration of economics, reliability, and resilience benefits.**
 - Individual microgrid designs should be able to explore generation and storage assets, system layout, and etc. with the overall networked microgrid configuration as reference.
- **Ability to study aggregation and joint management of uncertainty for improved control of variable and stochastic resources in distribution networks.**
- **Evaluation of dynamic feasibility of microgrid operations and control (both networked and individual).**
 - As individual microgrids and networked microgrids have lower inertia when islanded, dynamic transients are of increased concerns during intentional switching or protection-driven operations. These transients can have severe impacts on generation assets.
 - Due to low inertia, must also account for latency and reliability of communications and controls during faster dynamical transients.

- **Ability to study cyber-physical interaction of microgrid communication and transient/control/optimization impact within networked model.**
 - High-fidelity simulation/modeling via controller-in-the-loop (CIL) or hardware-in-the-loop (HIL) testing are powerful tools for modeling and studying the cyber-physical interactions.

1.4. Requirements for Networked Microgrids OD&O Tool

The discussed networked microgrid design tool objectives encompassed regulatory environment and business case evaluation, architecture design and operational assessments under “normal” conditions, evaluation of resilience and reliability under “extreme” conditions, and enabling dynamic interaction and transient studies among other crucial factors. The table below summarize these factors with more detail and specific capabilities to convey the overall requirements needed for a networked microgrid OD&O tool, as derived from [4].

<i>Capability</i>	Networked Microgrid Tool		
	<i>General Power Systems Modeling</i>		
	Simulation	Optimal Operations	Optimal Design
<i>Power Flow</i>	3-phase unbalanced Full AC representation or a sufficient approx. Able to solve with multiple islands Resolved in both distribution network and microgrid		
<i>Quasi-Static Loads</i>	Radial and urban mesh networks		Radial networks
	Flexible Modeling of loads including: constant PQ, constant Z, and constant current		
<i>Dynamic Loads</i>	Time-series data inputs for load variability with ≤ 1 min. resolution	Time-series data inputs for load variability with ≤ 15 min. resolution	
	Resolve phasor dynamics of critical loads with AC-cycle time-scale resolution inside microgrids and on the network	Account for the impact of dynamics of loads on the feasibility of dispatch and topology optimization	N/A
<i>Quasi-Static Distributed Generation</i>	Flexible modeling of generation including constant PV/PQ and slack bus Include fossil-fired generation, PV, wind, and battery storage Include non-constant generator efficiency curves		
	Time-series data inputs for generation with ≤ 1 min. resolution	Time-series data inputs for generation with ≤ 15 min. resolution	
	N/A	Operational costs	Capital and operational costs

<i>Dynamic Distributed Generation</i>	Resolve the dynamics of important generators and associated controls with AC-cycle time-scale resolution inside the microgrids and on the networks	Account for the dynamics of generators during dispatch and topology optimization	N/A
<i>Transmission System Interface</i>	Simulate effects of quasi-static and dynamic changes of voltage and frequency at transmission-distribution interface	N/A	
<i>Controls Modeling</i>			
<i>Load and DER</i>	Resolve the quasi-static and dynamic response of advanced controls for load and DER	Resolve the quasi-static response of advanced controls for load and DER	
<i>System Topology</i>	Simulate scripted topology switching sequences including dynamics	<i>See Unit Commitment and Economic Dispatch Section</i>	
<i>Communications</i>	Includes the effects of latency, dropped packets, and interruptions	N/A	
<i>Reliability Analysis</i>			
<i>Fault and Protection Studies</i>	Computes fault currents and simulates protective device actions Simulates post-fault/post-clearing system dynamics	N/A	
<i>Contingency Analysis</i>	Automatically simulates lists of contingencies	<i>See Unit Commitment and Economic Dispatch Section</i>	
<i>Renewable Resource Variability</i>	User specified or default resource time-series (e.g., irradiance or wind speed) at ≤ 1 min. resolution	User specified or default resource time-series (e.g., irradiance or wind speed) at ≤ 15 min. resolution	
<i>Unit Commitment and Economic Dispatch</i>			
<i>Objectives</i>	N/A	Co-optimize energy and ancillary services (frequency regulation, spinning reserves, Var, Black Start)	

<i>Contingencies</i>	N/A	Includes N-1 contingency constraints for generators and critical power lines
<i>Topology</i>	N/A	Solves for optimal topology for cost and/or resilience Accounts for quasi-static and dynamic feasibility of topology switching
<i>Uncertainty</i>	N/A	Accounts for impact of generation and load uncertainty on constraints, reliability, and cost
<i>Multi-Layer Optimization and Control</i>	N/A	Able to represent multi-layer decision-making in generation dispatch and other operation optimization
<i>BES Market Integration</i>	N/A	Able to emulate bulk energy system markets to evaluate interactions with higher-level markets
<i>Optimal System Design</i>		
<i>Microgrid</i>	N/A	Generation type and capacity Topology optimization
<i>Distribution Network</i>	N/A	Network hardening and expansion optimization including new lines, switches, etc.
<i>Networked Microgrid</i>	N/A	Integrated design and siting of networked microgrids for economics, reliability, and resilience
<i>Extreme Events Modeling</i>	N/A	Model Component damage and network state post extreme-event
<i>Resilience Analysis</i>		
<i>Fragility Modeling</i>	Ability to simulate time-sequenced device/component failures for extreme events Ability to observe system impact and recovery efforts to assess overall resilience	N/A

The above summary table provides a comprehensive list of valuable tool capabilities for designing networked microgrids. Traditional analyses such as power flow, load analysis, contingency analysis, and etc. are as expected. However, capabilities unique to microgrids and networked microgrids are also presented; these include controls modeling for load and distributed energy resources (DERs) and optimal system design of networked microgrids.

With these important capabilities and requirements established for a networked microgrid OD&O tool, the subsequent step is to assess existing microgrid tools and determine what features are already existing and what is lacking (if there are gaps). The next section will describe various existing tools that can aid the design of networked microgrids.

2. EXISTING MICROGRID TOOLS AND RELEVANT CAPABILITIES

Existing microgrid design tools will be assessed next to identify the relevant capabilities as well as apparent gaps. The evaluation and comparison of these tools are in consideration of the networked microgrid OD&O objectives and requirements discussed previously. Additionally, power system solver platforms are also discussed and their role in aiding microgrid design.

2.1. Background on Microgrid Design

The design and implementation of microgrids is a multi-step process that requires careful analysis, resource planning, and detailed understanding of its operation. Microgrids are often designed with a specific purpose and application in mind, thus necessitating careful planning and execution to achieve the goal(s). This process involves:

- 1) Conceptualizing the microgrid purpose/ objectives and primary stakeholders
- 2) Planning the microgrid parameters (e.g., load profiles, tariff rates, DER costs) and performing techno-economic analysis
- 3) Designing the actual microgrid circuit and performing power system analysis to ensure effective operation
- 4) Constructing the microgrid network with installation of DERs and loads as well as control systems
- 5) Operating the microgrid

Microgrid design tools are often used in steps 2) and 3), which involves techno-economic analysis to determine what DER mix is optimal and cost-effective, DER placement, what the expected costs will be of operation, how the microgrid circuit should be designed, etc. These techno-economic models are used during the microgrid planning stage and power system analysis tools are used during the microgrid design phase to ensure stable operation (e.g., via static analysis, transient stability analysis). Furthermore, some tools enable reliability and resilience analyses to determine the performance of the planned microgrid during contingencies and/or unexpected events. Both techno-economic and power system analysis capabilities are required for an effective microgrid design tool. Various microgrid design tools have been developed recently, though not with a networked microgrid focus; the next couple sections will describe these existing tools and their capabilities.

2.2. Description of Existing Microgrid Design Tools

To explore what capabilities can be leveraged for the proposed OD&O tool, this section details various research-focused and either open-sourced or heavily-documented microgrid design tools.

2.2.1. *Microgrid Design Toolkit (MDT)*

The Microgrid Design Toolkit (MDT) is a decision-support software tool for microgrid designers in the early stages of the design process; it enables microgrid sizing analysis to determine the size and composition of a new microgrid and subsequently analyzes the configuration with a technology management optimization model and a performance reliability model [5]. The technology management model utilizes a genetic algorithm to create and refine different microgrid designs; the performance reliability model, which is simulation-based, assesses the performance of each design for straightforward comparison. Ultimately, the primary output is a set of efficient trade-off microgrid designs, also known as a Pareto frontier.

The primary benefits of MDT are understanding the trade space of design alternatives when planning a microgrid and assessing performance, reliability, economics, and other key features for candidate microgrid designs. It achieves this by performing discrete-event Monte-Carlo simulation and uses a multi-objective evolutionary algorithm for optimization where the objective function is to simultaneously extremize many metrics (cost, fuel use, renewable penetration, etc.). It can model both grid-connected and islanded operation (as separate capabilities), explore different investment options (e.g., addition of DERs/lines), and allow input of cost/market data. Lastly, aggregate design and optimization of multiple microgrids can be achieved for tightly-coupled or full-decoupled modes. A snapshot of the tool interfaces is shown in Figure 2 [5].

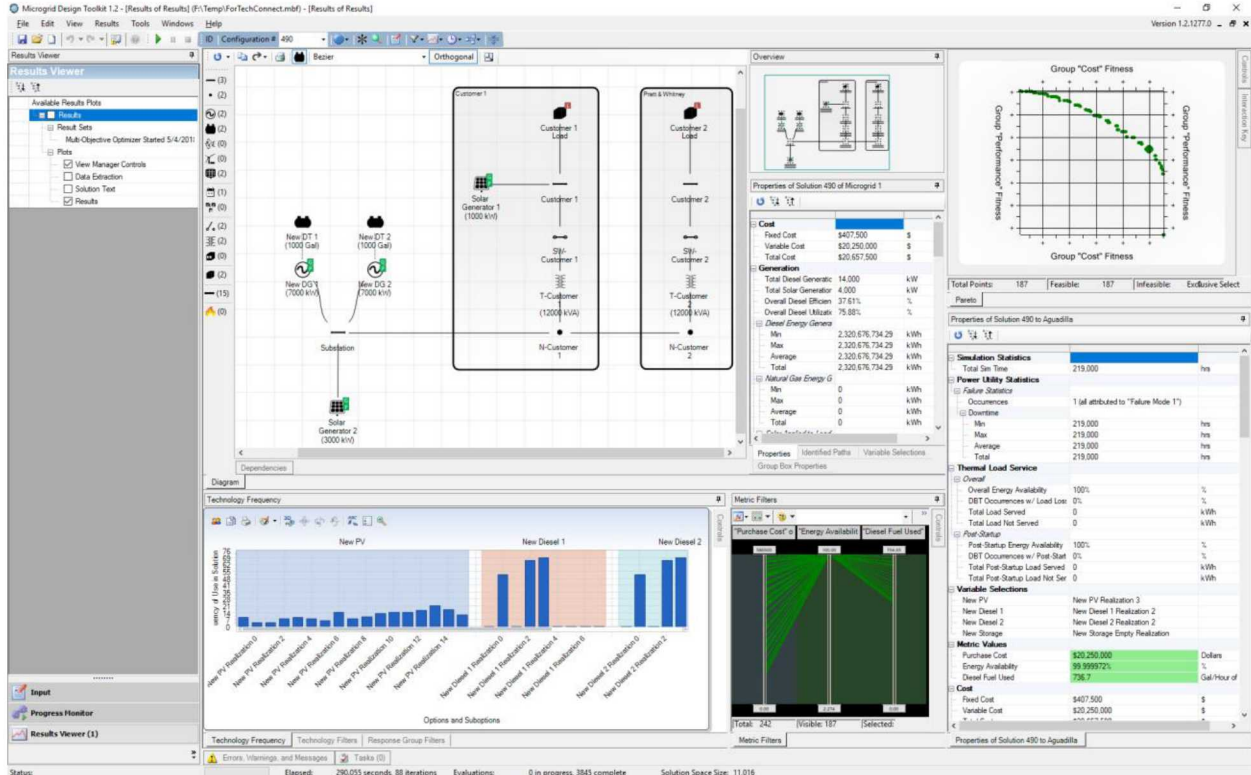

Figure 2: Snapshot of MDT tool interfaces [5].

2.2.2. Distributed Energy Resources – Customer Adoption Model (DER-CAM)

DER-CAM is a decision-support tool for decentralized energy systems [6]; it determines the least-cost combination and dispatch of DER and bulk power system (BPS) energy supply to meet microgrid loads at each node in a network. Essentially, DER-CAM optimizes DER adoption and hourly dispatch over a typical year for different “design day types”. This includes an average weekday, an average weekend day, and a peak/outlier day. Economic value is quantified for the value of installing and operating DERs; the value is the difference between the microgrid’s total energy cost and costs of supporting the same load profile using only utility electricity and fuel purchases. It possesses the following features:

- Can simultaneously find the optimal portfolio, sizing, placement, and dispatch of DERs for building and microgrid applications
- Enables objective definition for optimization; can perform multi-objective optimization
 - Performs mixed-integer linear programming (MILP) that can include costs

- Commonly defined DOE site's total annual cost of energy supply
- Can account for multiple revenue streams in optimization
- Supports both grid-connected and islanded operation (for economic scenarios)
- Supports multi-energy systems such as electric, cooling, and heating loads
- Considers both power and heat flow in multi-node systems
- Enables different investment options such as adding energy storage, PV, and generators
- Supports N-1 security constrained design
- Key inputs to the model include: End-use load profiles, DER technologies, Site-specific parameters (e.g., location and space constraints, local fuel costs)
- Key outputs of the model include: Energy flows (electricity, heating, cooling, fuels), Emissions, Associated costs from individual generation sources

The two main microgrid design challenges DER-CAM addresses is the investment and planning as well as operations-optimal dispatch. The mathematical basis for DER-CAM involves mixed-integer linear program (MILP) that enables DER-CAM to solve complex optimization problems quickly. DER-CAM performs economic investment and DER dispatch decision power flow simulations with a temporal resolution of 1 hour. Both cost/market data and regulatory framework information can be input to the model. Furthermore, DER-CAM can perform aggregate design and optimization of multiple microgrids as well as multiple microgrids via representation in unit commitment/dispatch optimization.

An example of the tool interface is provided in Figure 3. The key assumptions made for the tool, relevant to informing networked microgrid tool design, are that no deterioration in output or efficiency during the lifetime of the equipment is considered and reliability and power quality benefits for multiple units of the same technology are not directly taken into account. Also, reliability or power quality improvements accruing is only considered in terms of avoiding interruption costs (e.g., outage scenarios).

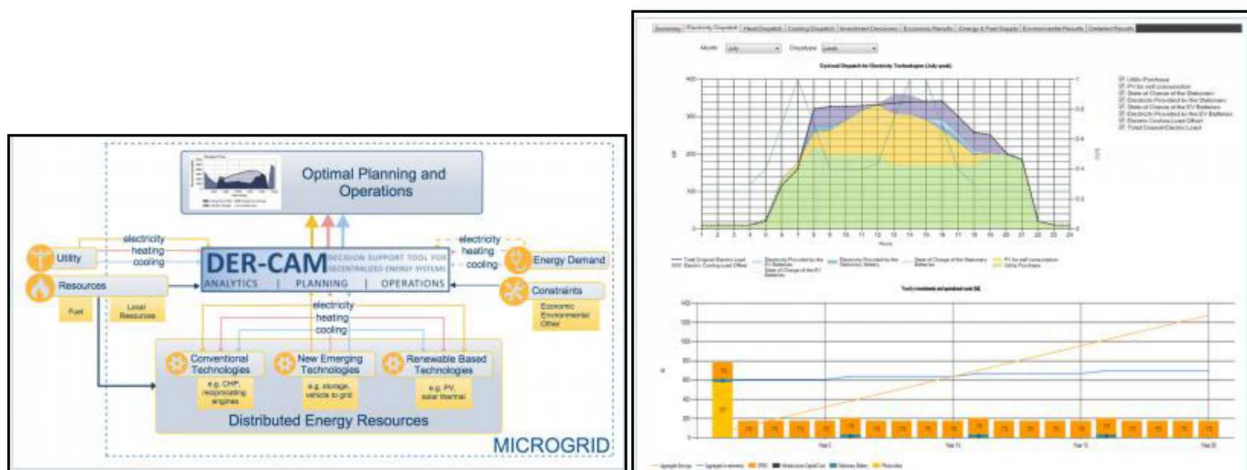

Figure 3: Example interface and results from DER-CAM tool [6].

2.2.3. Remote Off-Grid Microgrids Design Support Tool (ROMDST)

ROMDST extends the previously described DER-CAM into an optimal design support tool for remote, off-grid microgrids that improves resiliency and reliability. Remote communities are defined as a distant, isolated, populated area in which there is either limited or no access to an area electric power distribution system or the transport or storing (of portable fossil fuels) of electricity are very high. Specifically, it seeks to support analysis on alternating current and direct current remote off-grid microgrids to meet user-defined objectives and cost and system constraints [7].

It considers both nonlinear and discrete optimization methods where the objective function is to minimize the total investment; its temporal resolution is 1 hour for 365 days. ROMDST supports only islanded mode operation, with its focus on off-grid microgrids, and can explore various investment options ranging from adding new DERs to hardening lines. Both cost/market data and regulatory framework information can be input, if formed as constraints. Transactive energy actions can also be modeled in this manner (i.e., constraint form).

2.2.4. Microgrid Assisted Design for Remote Areas (MADRA)

The Microgrid Assisted Design for Remote Areas (MADRAs) is related a part of the ROMDST effort for addressing challenges in remote areas. It is a comprehensive design support tool for enabling the cost-effective design of off-grid DC and AC microgrids in remote areas [7]. It seeks to accelerate the deployment of microgrids by being used as a free and open-sourced tool. It boasts cost-efficient design based on an improved optimization model, integrated resources/component constraints and power flow model, enabling “N-1” reliability, and optional transient stability analysis [8]. A snapshot of the tool interface is shown in Figure 4.

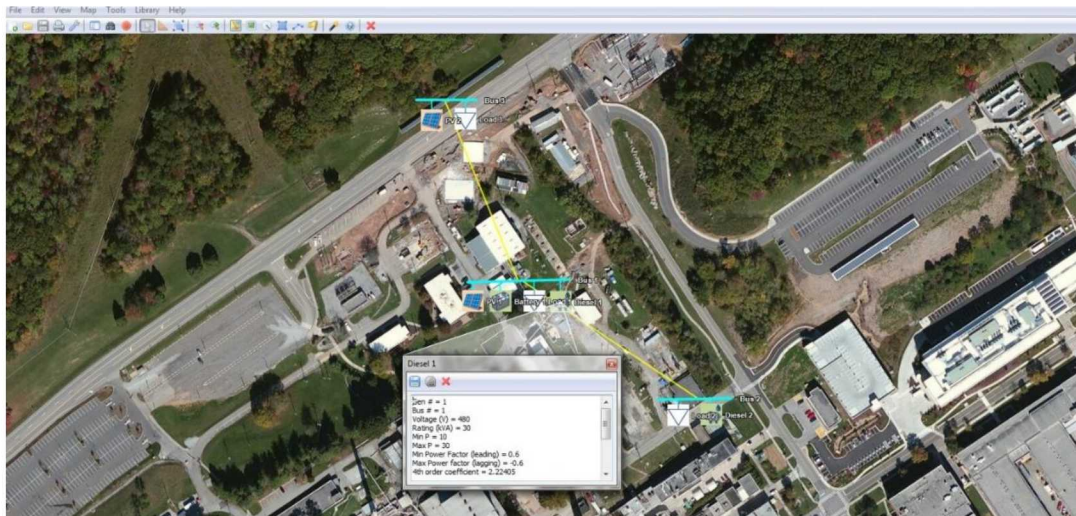

Figure 4: Snapshot of MADRA interface.

Specifically, it performs optimization for economic investment with dispatch decision using 1-hour temporal resolution; the optimization model is formulated as MILP with multi-objectives considering investment and operation cost or system loss or voltage deviation. Both islanded and grid-connected modes can be modeled in MADRA; both cost/market data and regulatory framework information can be input to the model. The optimization results are directly shown on the system diagram. Meanwhile, a report in Excel format will be automatically generated for detailed information. An example of the MADRA optimization results is shown in Figure 5.

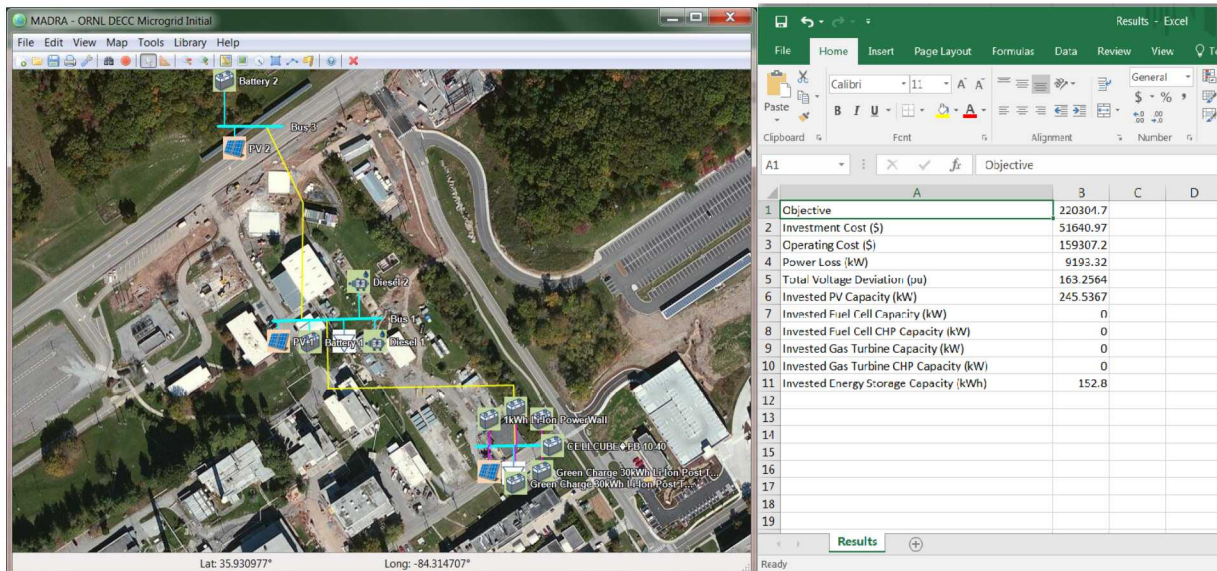

Figure 5: Example results of MADRA

2.2.5. Renewable Energy Integration and Optimization (REopt)

The REopt tool is a techno-economic decision support model used to optimize energy systems for buildings, campuses, communities, and microgrids [9]. The primary application of the model is for optimizing the integration and operation of behind-the-meter energy assets. Formulated as a mixed-integer linear program, REopt solves a deterministic optimization problem to determine the optimal selection, sizing, and dispatch strategy of technologies chosen from a candidate pool such that electrical, thermal, and water loads are met at every time step at the minimum life cycle cost. REopt is a time series model in which energy balances are ensured at each time step (with flexible temporal resolution from 1 minute to hourly) and operational constraints are upheld while minimizing the cost of energy services for a given customer. REopt solves a single-year optimization to determine N-year cash flows, assuming constant production and consumption over all N years of the desired analysis period. The tool relies on detailed economic inputs including complex utility rate tariffs, value streams from grid services, regulatory constraints, and technology cost data.

REopt can model both grid-connected and islanded systems. REopt optimizes size and dispatch of energy generation and storage assets in a microgrid to minimize life-cycle costs of energy while sustaining critical load for specified periods of time. Because of the explicit modeling of the utility grid within REopt, the model can be used to simulate grid outages by turning off the grid for certain time steps. This approach enables evaluation of all technologies in the model, both during grid-connected mode (vast majority of the year) and grid outages when technologies may continue to power critical loads as part of a microgrid. This capability is especially important for RE technologies because they are able to generate value during grid-connected mode, while also supporting a critical load during a grid outage (whereas backup generators may only be able to operate during an outage because of regulatory requirements). The tool determines economic benefits of systems and assesses the resilience provided during disturbances (i.e., the amount of time the critical load can be sustained, as a probabilistic distribution). Value of resilience, or avoided outage costs, can also be included in the objective function.

REopt answers questions such as:

- What is the business case for my microgrid?
 - What are the value streams I can access while grid-connected to recoup microgrid costs?
 - What is the value of avoided outages?
- What is the most cost-effective mix of generation and storage assets to meet my critical load for grid outages of various lengths?
 - How do PV + storage economics compare to traditional back-up assets?
- How long can I survive an outage?
 - What is the probability of surviving outages of various lengths?
- What is the tradeoff between life-cycle cost and number of days of survivability?
- How should I dispatch assets in my microgrid for cost-savings when grid-connected?
- How should I dispatch assets in my microgrid given my critical load and limited fuel supply during an outage?

This framework is explained and visualized in Figure 4.

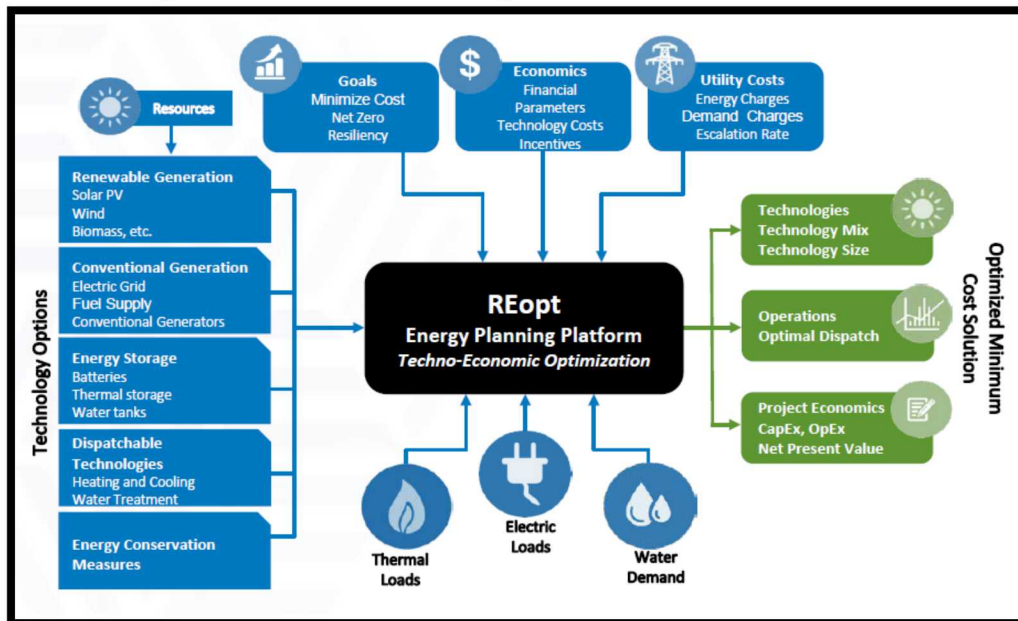

Figure 6: Visualization of REopt framework [9].

2.2.6. LPNORM: LANL PNNL NRECA Optimal Resiliency Model

The LPNORM software tool is focused on designing resilient distribution grids. Specifically, it seeks to support meeting the MYPP goal and DOE major outcome of achieving a 10% reduction in economic costs of power outages by 2025. It is being designed as an open-source distribution resilient design tool and is deployed on National Rural Electric Cooperative Association’s (NRECA’s) Open Modeling Framework (OMF) [10] [11] [12] [13].

The tool will combine existing capabilities and enable users to:

- Import distribution models
- Import communication models

- Specify extreme weather events
- Specify resiliency criteria
- Verify design solution quality with trusted power flow solvers

Specifically, LPNORM achieves steady-state simulation (using GridLab-D™) and performs optimization uses column generation with branch-and-price. It can handle both grid-connected and islanded modes of microgrid operation and enables reconfiguration controls, diverse investment options (e.g., distributed generation, adding and hardening lines, adding reclosers) and three-phase unbalanced power flow. LPNORM can model simple communications, perform indirect reliability analysis, and perform resilience analysis. An example of the LPNORM system architecture is provided in Figure 5.

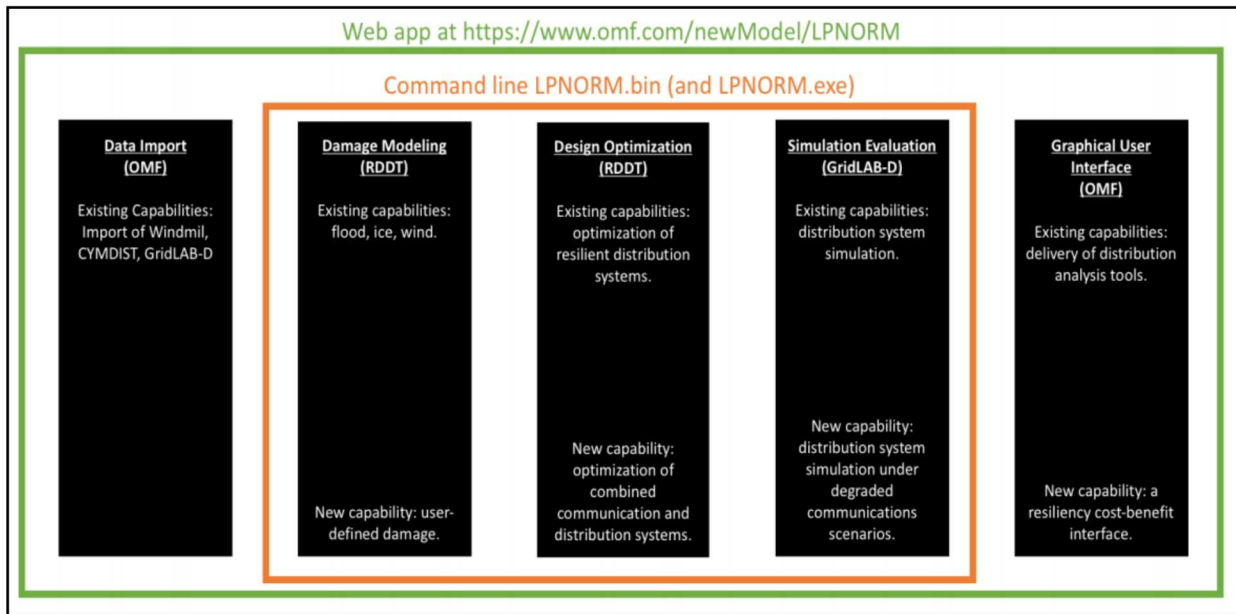

Figure 7: LPNORM system architecture [10].

2.2.7. Comparison of Microgrid Design Tool Features

A comparison of the microgrid design tools described in Section 2.2 is shown in Table 1. These tools are of specific interest for this report and the development of the proposed OD&O networked microgrid design tool; these tools are noncommercial and research-focused, thus, able to be leveraged without licensing issues. Furthermore, some are open-sourced and the remaining are heavily-documented and have plans of being open-source in the future.

For simulation type, the “N/A” input implies that the tool is not designed for typical discrete-event or continuous simulation, but for decision and design support. Operation mode “GC” denotes grid-connected and “I” denotes islanded; “GCI” indicates that both operation modes are handled.

Finally, user customization level (low, medium, high) assignment is based on if the tool is open-source, if the formulation or “math” is available, and if modules can be switched out readily. For example, DER-CAM is not open-source but the math is published—thus, it is assigned a medium level of user customization. A user can understand how the tool works, its basis, and build one of similar design or extend the capabilities of DER-CAM with deeper understanding of the details.

Table 1: Comparison of Noncommercial, Research-Focused Microgrid Design Tools

	REopt	DER-CAM	MDT	ROMDST	MADRA	LPNORM
Created By	NREL	LBNL	SNL	LBNL	ORNL	LANL, PNNL, NRECA
Simulation Type	Economic Investment and Dispatch Decision	Economic Investment and Dispatch Decision	Discrete-Event Monte Carlo	N/A	Economic Investment and Dispatch Decision	Three-Phase Power Flow
Optimization Method	Mixed-Integer Linear Programming	Mixed-Integer Linear Programming	Multi-Objective Evolutionary Alg./MILP	Nonlinear and Discrete Methods	Mixed-Integer Linear Programming	MINLP solved with a Column Generation with Branch-and-Price approach
Power Flow Solved	Yes	Yes	No	Yes	Yes	Yes
Three-Phase Unbalanced Power Flow Modeling	No	No	No	No	No	Yes
Dynamic Transient Analysis	No	No	No	No	No	No
Resolution	1 Minute to Hours	1 Hour	N/A	1 Hour	1 Hour	N/A
Operation Modes	GCI	GCI	GCI	I	GCI	GCI
Electrical Load Modeling	Yes	Yes	Yes	Yes	Yes	Yes
Thermal Load Modeling	Yes	Yes	Yes	Yes	Yes	Yes
Communication Modeling	No	No	No	No	No	Yes
Fault Analysis	No	No	No	No	No	No
Distributed Generation Technology Capabilities	Yes	Yes	Yes	Yes	Yes	Yes
Energy Storage Capabilities	Yes	Yes	Yes	Yes	Yes	No
Cost/Market Input Data	Yes	Yes	Yes	Yes	Yes	No
User Customization of Code	Medium	Medium	Low	High	High	High

2.3. Description of Commercial Microgrid Design Tools

In this section, a collection of commercial microgrid design tools are described. These tools, though cannot be used in the development of the proposed OD&O tool due to licensing issues, offer further insight into the capabilities and applications for microgrid design. These features can be used to inform the needs and gaps apparent for designing networked microgrids.

2.3.1. Hybrid Optimization of Multiple Energy Resources (HOMER) Pro

The HOMER Pro tool is an optimization model that focuses on the hybrid optimization of multiple energy resources and simulates long-term investments in microgrid systems; it enables simulation in small time-steps (1 minute to 1 hour) for operation up to 1 year, optimization, and sensitivity analysis for a variety of inputs [14]. The optimization component can aid in identifying least-cost options for microgrids or other systems and the sensitivity analysis enables careful study of different variable impacts. This is done by comparing different system configurations to identify the lowest-cost DER mix and dispatch schedule. This comparison is performed in a user-defined search space. An example for fuel costs is shown in Figure 6.

There are various HOMER software tool types, from focus on islanded microgrids and complex reliability issues (HOMER Pro) to providing simplistic DER mix analysis (HOMER QuickStart). HOMER has several libraries of data for load profiles, DER technologies, and location-specific data (e.g., solar irradiance). These can be used along with a range of microgrid configurations to create the user-defined search space. Ultimately, HOMER determines the lowest-cost solution for supporting the microgrid load and provides the lifecycle cost of the system.

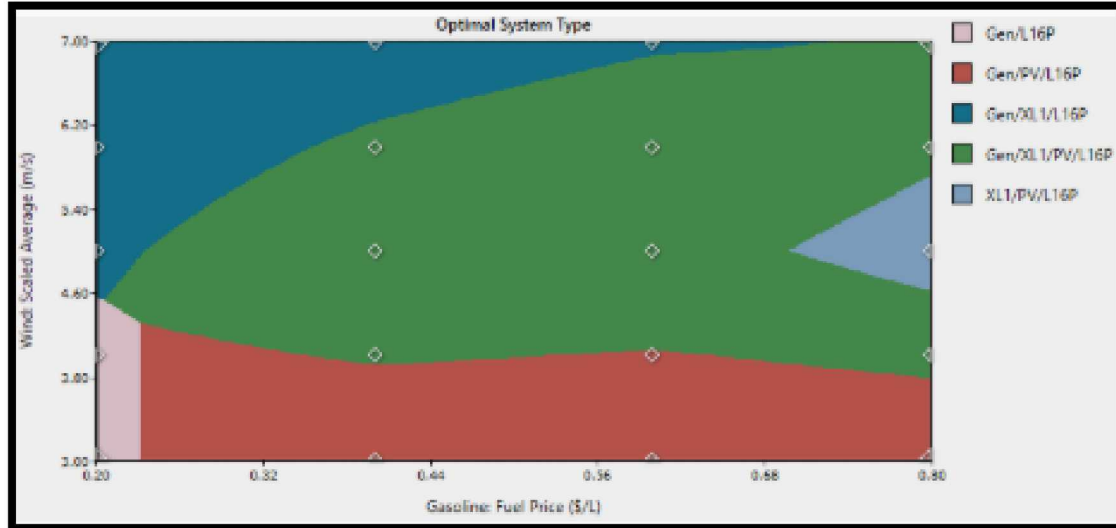

Figure 6: Sensitivity analysis of fuel price impact [14].

2.3.2. Xendee

The Xendee tool is a cloud platform that integrates OpenDSS, as detailed in the next section, and DER-CAM tools to achieve smart grid analytics and Microsoft cloud technologies to deliver scalable web services that enable collaboration and flexibility. Specifically, for simulation of DERs, the Xendee scripts can be directly edited to simulate:

- Vendor-specific inverter characteristics
- Second-to-second to yearly timelines for small-scale and large-scale PV integration
- Higher penetration scenarios where feeder loading and grid impact analysis is required

Other features include microgrid project management, power flow analysis, motor-starting analysis, short-circuit analysis, one-line diagram design, analysis and reporting, and collaboration capabilities [15].

2.3.3. ETAP Microgrid

The ETAP Microgrid tool is an integrated power system simulation, planning, protection, and real-time microgrid master controller [16]. It monitors, predicts, manages, and optimizes energy supply and demand for small-scale energy systems through DER technologies with intelligent software. A mix of DERs with traditional generation sources can be included in model to study coordinated control between the distribution management system (DMS) and local microgrid controllers.

Thus, ETAP Microgrid can be used to build and validate designs with real-time information and includes key functionalities such as: detailed modeling, simulation and optimization of complex dynamic power systems, predictive analysis and forecasting of loads and generation, modeling of microgrid elements, including PV, energy storage devices, diesel generators, wind turbines, and other elements, and fast load shedding, automatic generation control and demand management. An example of the ETAP Microgrid interface is shown in Figure 7.

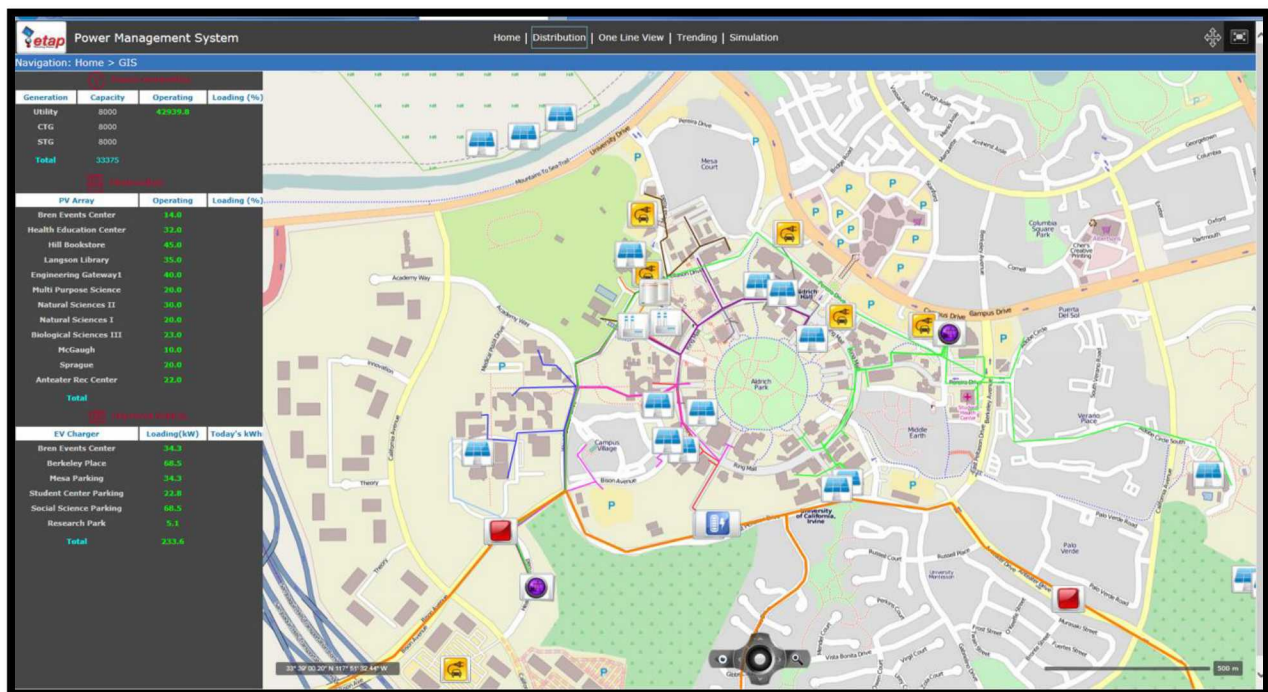

Figure 7: ETAP Microgrid interface [16].

2.3.4. Siemens SICAM Microgrid Manager

The Siemens SICAM Microgrid Manager provides automated planning, forecasting, modeling, and real-time optimization for controlling all operating resources for microgrids [17]. The tool can monitor and control producers, storage systems, consumers, and re-adjust the generation and grid operation planning in real-time (can also incorporate historical data). All in all, it facilitates comprehensive planning, monitoring, and control of microgrids. An example of the tool structure and analyses is shown in Figure 8.

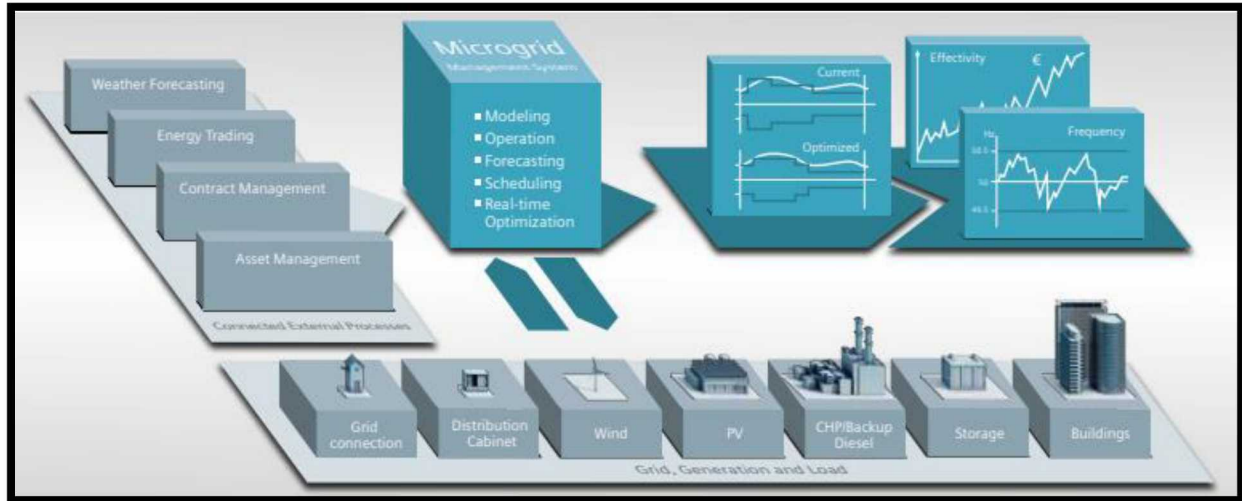

Figure 8: SICAM tool structure and analyses [17].

2.4. Description of Power System Solvers and Role in Designing Microgrids

Power system solvers play important roles in many of the microgrid design tools; they are often built into the optimization frameworks of the tools and don't need to be treated as a separate tool. However, for clarity, this section will detail a few of the prominent power system solvers used for microgrid design. All in all, power system solvers are used to provide operational insight, understand feasibility of the microgrid design, and planning connection to the BPS.

2.4.1. GridLAB-D™

GridLAB-D™ is a multi-disciplinary simulation environment that can conduct power distribution system simulations with the inclusion of smart grid elements; it is a flexible environment that can be integrated with different third-party data management and analysis tools. The main novelty of GridLAB-D™ is its core algorithm that simultaneously coordinates the state of millions of independent devices that are each described with multiple differential equations [18]. It couples power system modeling with end-use load, market, customer behavior, and investment models. It is a multi-domain simulation tool, it can enable different studies that can cover physical, economic, business, and customer behavior aspects of distribution systems. Thus, the main advantages compared with conventional finite difference-based platforms are:

- Can handle disparate time-scales
- Can integrate easily with third-party modules and systems
- Can model unusual cases
- Does not require reduced-order models for aggregate behaviors

The tool additionally boasts the following capabilities:

- Agent-based and information-based modeling tools
 - Enabling detailed distributed energy resource (DER) models
- Rate structure, consumer reaction, and interdependence study tools

2.4.2. OpenDSS

An open-source simulation tool, the Open Distribution System Simulator (OpenDSS) is a distribution system simulator that can support almost all frequency domain analyses that are usually performed at distribution utilities. It was originally designed to enable the analysis of distributed generation interconnected to utility distribution systems but can also perform analysis on energy efficiency of power delivery and harmonic current flow. The basic structure of OpenDSS is shown in Figure 9 and the object structure is shown in Figure 10 [19].

OpenDSS performs load-flow analysis of distribution feeders with DER and uses quasi-steady-state solution modes within OpenDSS to run sequential time series simulations in which distribution systems are simulated consecutively, at a user-defined timestep, over days or a year. In this manner, the user can perform various analyses relevant to microgrid simulation including time-specific and location-specific studies. It can also perform short-circuit, dynamic, and harmonic analyses.

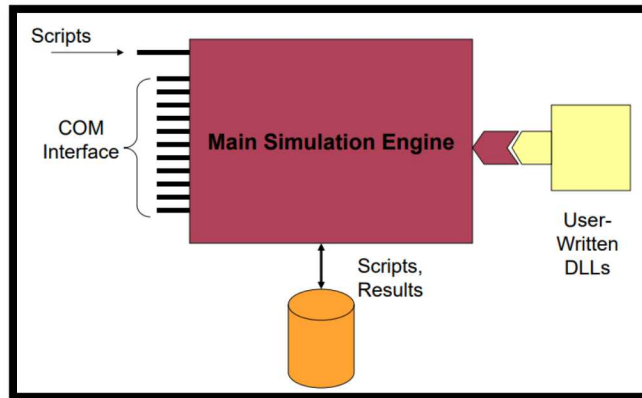

Figure 9: Structure of OpenDSS platform [19].

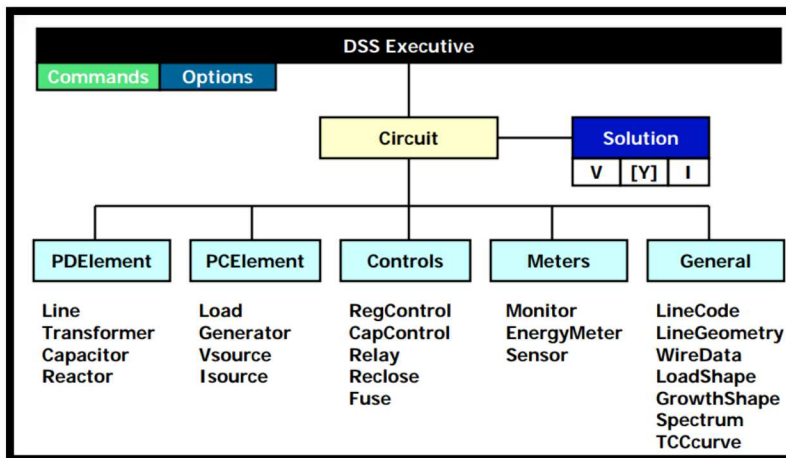

Figure 10: Object structure of OpenDSS platform [19].

2.4.3. Hierarchical Engine for Large-Scale Infrastructure Co-Simulation (HELICS)

The HELICS tool is an open-source, cyber-physical energy co-simulation platform that supports large-scale co-simulation with off-the-shelf power system, communication, market, and end-use tools. The key features are:

- Cross-platform operation system support
- Integration of both even-driven and time-series simulations
- Ability to co-iterate among federates to ensure physical model convergence at every time step

Therefore, it builds on existing tools to create a layered, high-performance co-simulation framework to achieve cyber-physical models that are increasingly scalable. The layered, co-simulation architecture is pictured in Figure 11 and highlights the key existing tools/subcomponents in each layer [20].

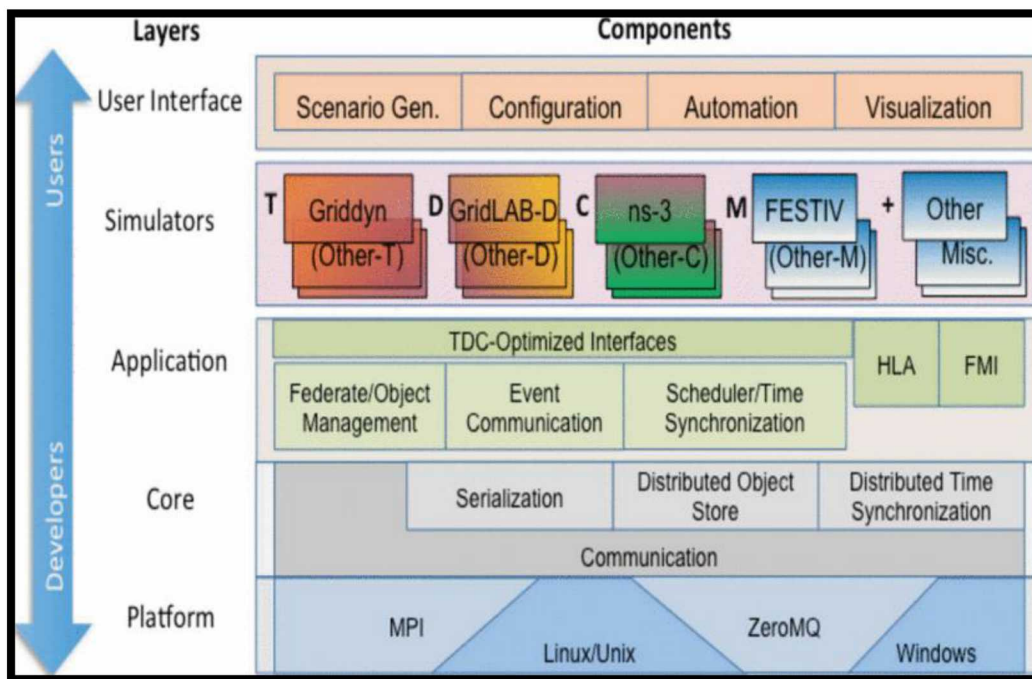

Figure 11: Architecture of the HELICS tool [20].

3. COMPARISON OF EXISTING TOOLS AND APPLICATION TO NETWORK MICROGRID DESIGN

As described in the previous section, there are various microgrid design tools available. The focus of this report is to identify the needs for a networked microgrid design tool; by examining existing tools, we can identify which capabilities are already existent, and subsequently identify the gaps and needs to be addressed. The eventual goal is to develop a tool that addresses all the requirements for designing networked microgrids, this is captured in the proposed OD&O tool column and discussed in Section 1.4. As this effort will be a research-focused, we only compare with noncommercial tools described in Section 2.2. The comparison of these tools and their capabilities are captured in the table below. The “X” denotes inclusion of the specific capability whereas the “/” denotes partial inclusion. Some of the key characteristics needed for a networked microgrids OD&O tool are:

1. **Optimization of Design** – the microgrid design options and investments are analyzed inside an optimization framework to solve the system for the best solution.
2. **Multiple Microgrid Controllers** – the ability to include multiple microgrid controllers for tightly-coupled and loosely-couple microgrids that can work in unison or individually, including the networking control logic for when and how to connect multiple microgrids. Some existing tools have partial solutions for this with multiple controllers that can work individually.
3. **Adding Lines and Hardening Lines** – the ability to include additional lines and hardening lines as an investment option for improving reliability/resilience.
4. **Three-phase Unbalanced Power Flow** – the algorithms necessary to solve multi-phase (combinations of three-phase and single-phase) systems with nonsymmetric line impedances and unbalanced currents. Since the majority of distribution systems are unbalanced with single-phase laterals, this is critical for simulating the existing customers and system.
5. **Microgrid Reconfiguration** – the ability to reconfigure the microgrid for line loss minimization or reconfiguration for restoration after a fault. Some existing tools have partial solutions to reconfigure to enforce radial systems.
6. **Fault Analysis and Protection Design** – the ability to perform fault simulations inside the microgrid and include the protection design to ensure the system is secure and coordinated.
7. **Transients during Switching** – the ability to perform dynamic transient analysis for load transients and switching transients for connection/disconnecting from the grid.
8. **Market Models** – energy market models with inputs for cost/market data when grid-connected and energy markets inside the microgrid when islanded, such as transactive energy. Most tools include the capability to model cost and market data when grid-connected, but networked microgrids will need to be able to simulate the market mechanisms between customers inside the microgrids and between microgrids.
9. **Regulatory Framework** – the ability to include the regulatory framework for ownership, right of way, assets, and safety. Networked microgrids will require the ability to include multi-ownership models in the regulatory framework. Some existing tool have partial solutions for including the regulatory framework by including them as constraints in the optimization.
10. **N-1 Reliability Analysis of the Microgrid** – the ability to analyze outage scenarios, N-1, or reliability calculations using failure probabilities for each component. Some existing tools have partial solutions by hard coding each N-1 or outage as a scenario for analysis.
11. **Resilience Scenario Analysis** – the ability to analyze high consequence events using specific damage scenarios or design basis threat scenarios.

12. **Open-Source** – the code is accessible and usable for inclusion into other tools. While most of the DOE tools in the table below are freeware, distributed to anyone without fee or obligation, the code is not accessible for inclusion or expansion.

Table 2: Comparison of Existing Tool Capabilities and Proposed OD&O Tool for Networked Microgrid Application

	REopt	DER-CAM	MDT	ROMDST	MADRA	LPNORM	Proposed OD&O
1. Optimization of Design	X	X	X	X	X	X	X
2. Multiple Microgrid Controllers			/				X
3. Adding Lines and Hardening Lines			X	X		X	X
4. Three-phase Unbalanced Power Flow						X	X
5. Microgrid Reconfiguration			X	/		/	X
6. Fault Analysis and Protection Design							X
7. Transients during Switching							X
8. Market Models	X	/	/	/	/		X
9. Regulatory Framework	X	X		/	X	/	X
10. N-1 Reliability Analysis of Microgrid		X	X	X	X	/	X
11. Resilience Scenario Analysis	X		X			X	X
12. Open-Source				X	X	X	X

3.1. Gaps in Current Tools for Networked Microgrids and Future Needs

The existing noncommercial microgrid tools, summarized in Section 2.2, and compared in Table 2 are assessed with regards to their suitability for designing networked microgrids. The rows of the table list different capabilities/features that have been identified as crucial for networked microgrid design and analysis. Many of the existing microgrid design tools boast optimization, “N-1” reliability analysis, some resilience analysis, regulatory framework/ market model input, and hardening capabilities that are essential to networked microgrid design.

However, some obvious gaps exist, such as the inclusion of multiple microgrid controllers, microgrid reconfiguration, three-phase unbalanced power flow, fault analysis and protection design, and modeling transients during switching. These gaps either had no tools with the capability or only partial capability. However, this is to be expected, as networked microgrid design introduces a separate set of challenges than traditional microgrids (e.g., switching transients). The next couple sections will discuss 1) what existing capabilities can be leveraged from traditional microgrid tools for the proposed OD&O tool for networked microgrids and 2) what gaps need to be addressed and included in the proposed OD&O tool.

3.2. Mapping of External Tools to Networked Microgrid OD&O Needs

The noncommercial, research-focused microgrid design tools discussed enable useful design features such as the ability to investigate simultaneous impact of events/changes to different microgrid topologies, dynamic modeling, multi-node modeling, ability to consider different load shifting/scheduling/shedding changes, and addition of DER technologies. These features will be included in the networked microgrid OD&O tool; this can be achieved by leveraging some of the open-source tools as compared in Table 1 and Table 2. It is also important to note that a couple of the tools have plans to be open-source in the future and/or at least have the mathematical basis available via papers/documentation.

These existing features, though necessary and useful for the design and analysis of networked microgrids, do not address all the design and optimization needs unique to networked microgrids. The needs that still need to be addressed are:

- Comparison of networked microgrid sites, not just individual sites
- Need to optimize among sites and design accordingly
- Analysis of control and placement of multiple microgrid controllers
- Fault analysis and protection design of all sites
- Modeling of transients during switching
- Microgrid reconfiguration studies, especially when networked microgrid system changes (different microgrids switch in or out)

These needs are essential for designing networked microgrids and must be included in the proposed OD&O tool. From the existing set of capabilities for designing microgrids, we know we have the ability to perform power flow analysis, comparison of separate sites, observe simultaneous impact, study placement of DERs, perform economic analyses, perform optimization, and etc. Thus, we do not need to start from scratch; we need to leverage these features and build upon them to achieve a suitable networked microgrid design and analysis tool.

3.3. Addressing the Gaps: New Capabilities for Core OD&O Tool

Some key features, though available, that need to be improved include the incorporation of advanced communication models. Tools such as LPNORM enable importing communication models, but the types and fidelity of models must be assessed. For example, is deep-packet inspection or higher-level network flow analysis needed to understand the cyber-physical impact of switching transients in networked microgrids? Another challenge is the optimization between different control schemes and operating paradigms of networked microgrids, especially as the site membership changes, including the study of inertial differences.

An additional unique challenge is business case evaluation in different regulatory environments, as different microgrid sites can belong to different regulatory environments yet be networked together. For the feasibility of such a configuration, it would be of interest to enable the usage of different rates/tariffs in the same networked model. The proposed OD&O tool can pull from traditional microgrid tools that allow input of market and tariff data into the overall model and then add additional features that allow those datasets to vary across a model. In this manner, a networked microgrid that includes sites across regulatory frameworks can be represented.

Fault analysis and protection design is not always available in microgrid design tools but are common features for general power system analysis platforms. It is important for the OD&O tool

to incorporate such analysis so operational analysis across the microgrids can be performed. Furthermore, a pertinent issue to be explored for networked microgrids is if a fault propagates through the network and damage is incurred, who is responsible? These important questions must be explored within the OD&O tool to understand both the technical and business case implications.

4. CONCLUSIONS

All in all, the proposed OD&O tool will leverage existing design and operation features for traditional microgrids, build upon available techniques to fit the networked microgrid needs (e.g., more detailed communication models), and develop new capabilities to address vital gaps. This may be achieved through a tool framework that allows the insertion of different software modules depending on the unique needs of the networked configuration(s) or a general-purpose tool that can handle all the critical features identified in Table 2. Nonetheless, to ensure the successful development of the OD&O tool, deeper understanding and study of networked microgrids is needed; the proposed OD&O tool must capture and allow detailed exploration of all the interdependent cyber-physical, business case, and control paradigm intricacies.

5. REFERENCES

- [1] Z. Li, M. Shaidehpour, F. Aminifar, A. Alabdulwahab and Y. Al-Turki, "Networked Microgrids for Enhancing the Power System Resilience," *Proceedings of the IEEE*, vol. 105, no. 7, 2017.
- [2] G. Liu, T. B. Ollis, B. Xiao, X. Zhang and K. Tomsovic, "Networked Microgrids for Improving Economics and Resiliency," in *2018 IEEE Power & Energy Society General Meeting (PESGM)*, 2018.
- [3] S. Hossain-McKenzie, E. C. Piescorovsky, M. J. Reno and J. C. Hambrick, "Microgrid Fault Location: Challenges and Solutions," Sandia National Laboratories, SAND2018-6745, 2018.
- [4] S. Backhaus, L. Dobriansky, S. Glover, C.-C. Liu, P. Looney, S. Mashayekh, A. Pratt, K. Schneider, M. Stadler, M. Starke, J. Wang and M. Yue, "Networked Microgrids Scoping Study," Los Alamos National Laboratory, 2016.
- [5] Sandia National Laboratories, "MDT: Microgrid Design Toolkit," 2019. [Online]. Available: <https://www.sandia.gov/CSR/tools/mdt.html>.
- [6] Microgrids at Berkeley Lab, "Distributed Energy Resources - Customer Adoption Model (DER-CAM)," 2019. [Online]. Available: <https://building-microgrid.lbl.gov/projects/der-cam>.
- [7] DOE Office of Electricity, "OE Announces Awardees Under the Remote Off-Grid Microgrid Design Support Tool Research Call," 2015. [Online]. Available: <https://www.energy.gov/oe/articles/oe-announces-awardees-under-remote-grid-microgrid-design-support-tool-research-call>.
- [8] M. Starke, "ORNLDOE/OE/ORNL," 2016. [Online]. Available: https://www.sandia.gov/ess-ssl/docs/pr_conferences/2016/Monday_Presentations/6_Michael_Starke.pdf.
- [9] D. Cutler, D. Olis, E. Elgqvist, X. Li, N. Laws, N. DiOrio, A. Walker and K. Anderson, "REopt: A Platform for Energy System Integration and Optimization," National Renewable Energy Laboratory, NREL/TP-7A40-70022, 2017.
- [10] R. Bent, "2016 Smart Grid R&D Program Peer Review: Project Summary: LPNORM: A LANL, PNNL, and NRECA Optimal Resiliency Model," 2016. [Online]. Available: http://e2rg.com/documents/Day%20two-AM-Web/2016%20SG%20Peer%20Review%20Summary_Bent.pdf.
- [11] A. Barnes, H. Nagarajan, E. Yamagil, R. Bent and S. Backhaus, "Resilient Design of Large-Scale Distribution Feeders with Networked Microgrids," *Electric Power Systems Research*.
- [12] G. Byeon, P. V. Hentenryck, R. Bent and H. Nagarajan, "Communication-Constrained Expansion Planning for Resilient Distribution Systems," *INFORMS Journal of Computing*.
- [13] "Optimal Resiliency Model," [Online]. Available: <http://www.omf.com>.
- [14] HOMER Energy, "HOMER Pro," 2018. [Online]. Available: <https://www.homerenergy.com/products/pro/index.html>.
- [15] XENDEE Bankable Energy, "Design and Manage The Future of Electrical Power: Anywhere. Anytime.," 2019. [Online]. Available: <https://www.xendee.com/>.

- [16] ETAP: Powering Success, "Microgrid Management and Control," 2018. [Online]. Available: <https://etap.com/renewable-energy/etap-microgrid-fundamentals>.
- [17] Siemens, "Microgrids under perfect control," [Online]. Available: <https://w3.usa.siemens.com/smartgrid/us/en/microgrid/Documents/SICAM-scada-system-for-microgrid-security.pdf>.
- [18] GridLab-D (TM), "GridLab-D (TM): A Unique Tool to Design the Smart Grid," 2018. [Online]. Available: <https://www.gridlabd.org/>.
- [19] R. Dugan, "OpenDSS Introductory Training Level 1," EPRI: Electric Reserach Power Institute, 2009.
- [20] B. Palmintier, D. Krishnamurthy, P. Top, S. Smith, J. Daily and J. Fuller, "Design of the HELICS high-performance transmission-distribution-communication-market co-simulation framework," in *2017 Workshop on Modeling and Simulation of Cyber-Physical Energy Systems (MSCPES)*, Pittsburgh, 2017.

DISTRIBUTION

Email—External

Name	Company Email Address	Company Name
Dan Ton	dan.ton@hq.doe.gov	DOE Office of Electricity
Kevin Schneider	kevin.schneider@pnnl.gov	Pacific Northwest National Lab

Email—Internal

Name	Org.	Sandia Email Address
Shamina Hossain-McKenzie	5821	shossai@sandia.gov
Matthew Reno	8813	mjreno@sandia.gov
John Eddy	8723	jpegdy@sandia.gov
Abraham Ellis	8812	aellis@sandia.gov
Technical Library	9536	libref@sandia.gov

This page left blank

This page left blank



Sandia
National
Laboratories

Sandia National Laboratories is a multimission laboratory managed and operated by National Technology & Engineering Solutions of Sandia LLC, a wholly owned subsidiary of Honeywell International Inc. for the U.S. Department of Energy's National Nuclear Security Administration under contract DE-NA0003525.