

Finite Element Analysis at Sandia National Laboratories

Jerrod Peterson
Stanford University
May 23, 2011

Sandia is a multiprogram laboratory operated by Sandia Corporation, a Lockheed Martin Company,
for the United States Department of Energy's National Nuclear Security Administration
under contract DE-AC04-94AL85000.



Introduction

- My background
 - Technical Staff,
Sandia National Labs
 - Ph.D. candidate,
Mechanical Engineering
- My department's role
 - Design & testing of
telemetry systems
(ruggedized electronics)
 - Interdisciplinary (EE, ME)
- My roles
 - Mechanical engineering
 - Design & solid modeling
 - Analysis (FEA)
- My interests
 - Modeling circuit boards
in vibration & shock
 - Bringing FEA into
conceptual design

Presentation outline

- Use of FEA at Sandia
 - Codes used
 - Examples FEA analyses from Sandia
- My research
 - FEA during conceptual design of electronics packaging
- Roles & responsibilities at Sandia
- Model flow from CAD to FEA
- Overview of structural dynamics

FEA software used at Sandia

- Commercial FEA codes
 - Abaqus
 - Nastran
 - Ansys
- Commercial FEA codes integrated with solid modeling software
 - Pro/Mechanica
 - Solidworks Simulations (Cosmos)
- Sandia proprietary FEA codes
 - Cubit
 - Presto
 - Adagio
 - Salinas
 - Tahoe
 - Alegra
 - Autodyne

FEA at Sandia: Highly detailed designs

Structural analysis of a wind turbine blade ^[1]

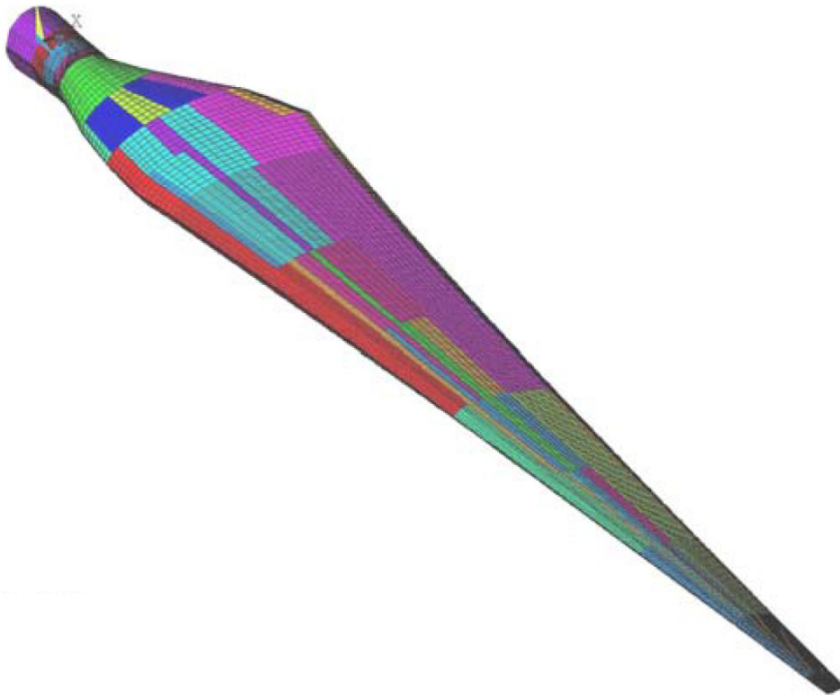

Thermal analysis of an electro-mechanical component ^[2]

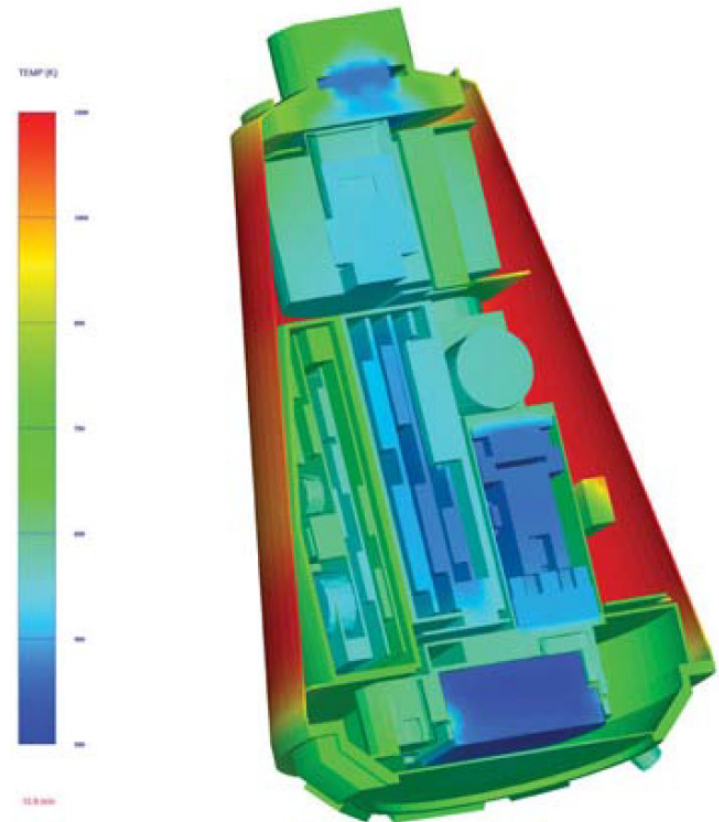

FEA at Sandia: Highly detailed designs

Vibration analysis of an entire weapon system ^[3]

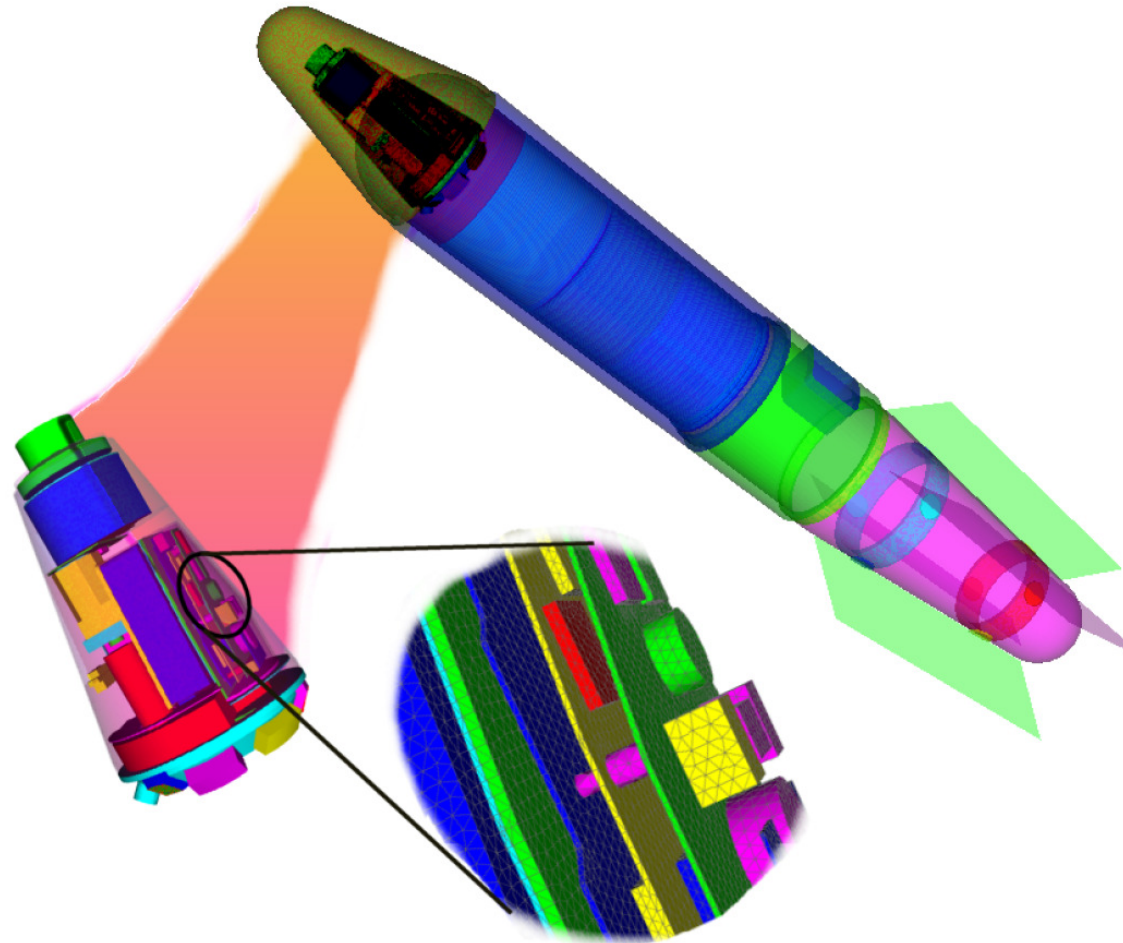

FEA at Sandia: Highly detailed designs

Modal analysis of a next-generation lithographic system ^[3]

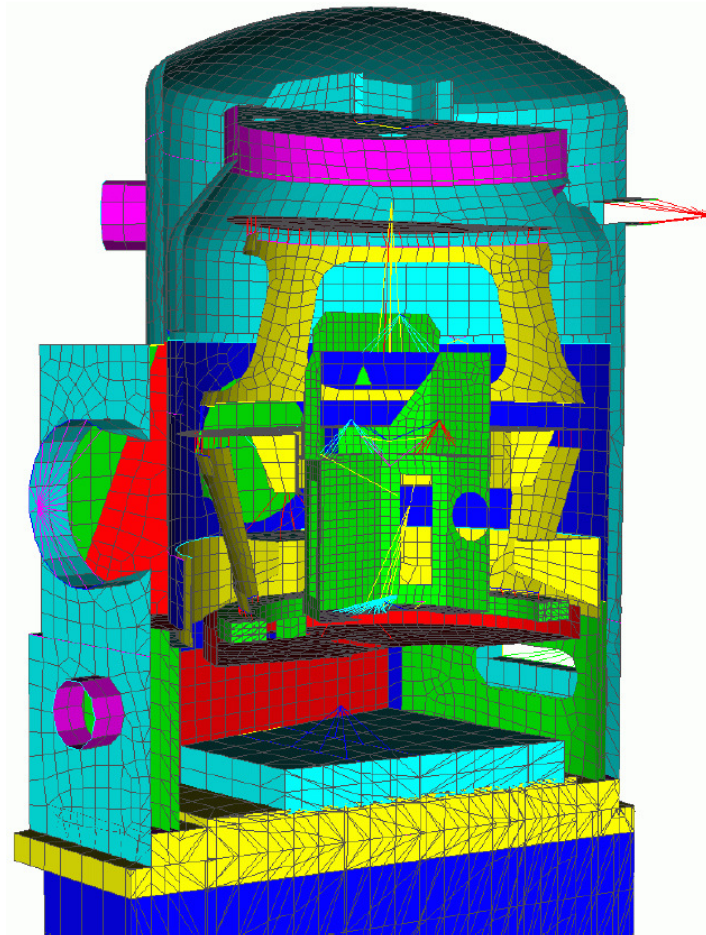

FEA at Sandia: Multi-physics models

Ablation characteristics at nose of weapon [4]

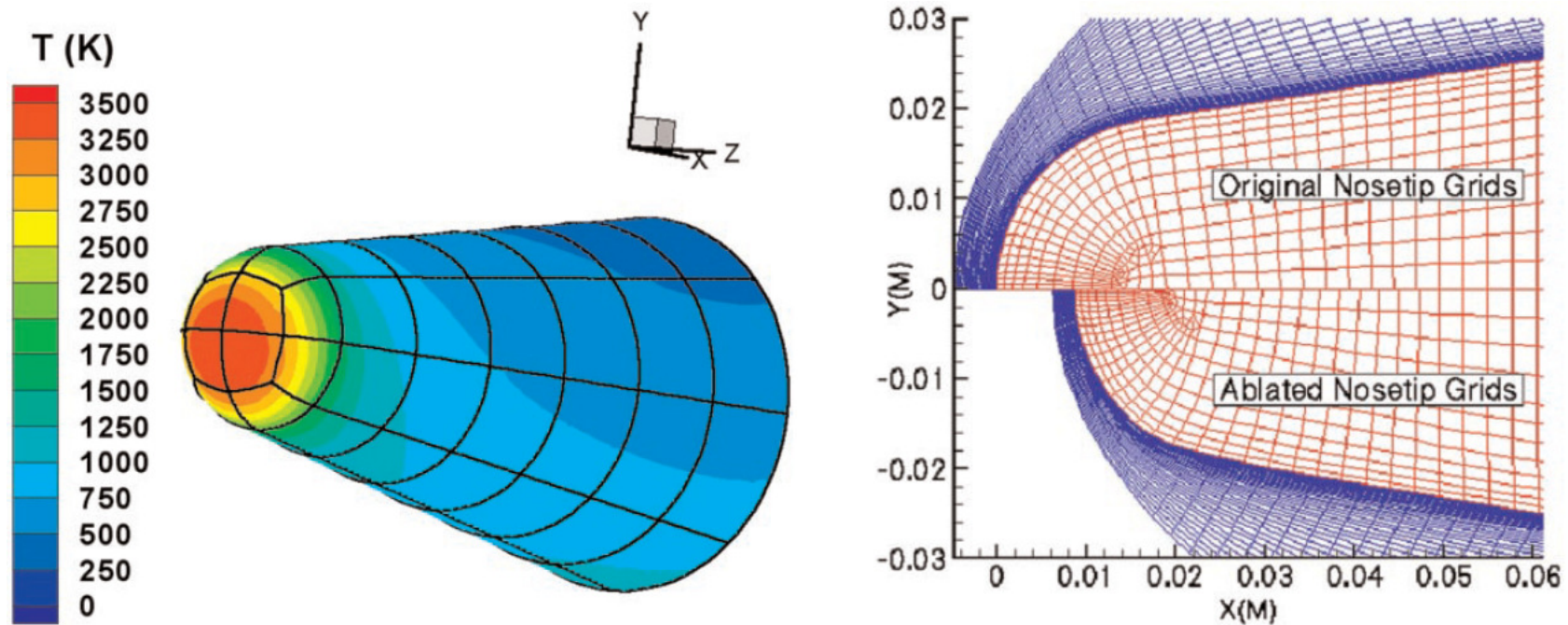

FEA at Sandia: Multi-physics models

Bullet piercing through a plate [5]

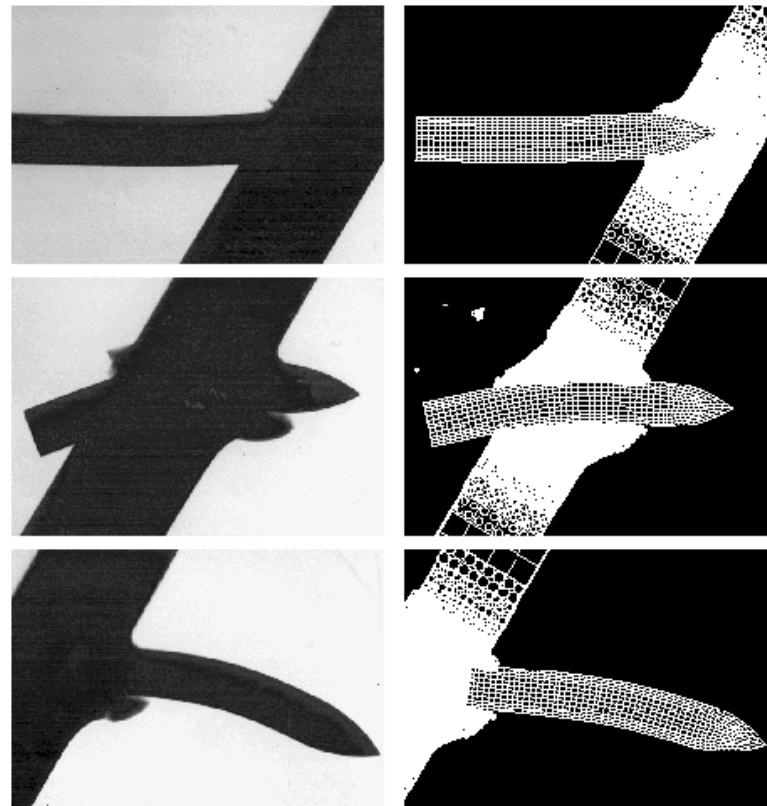

FEA at Sandia: Multi-physics models

Weapon impacting rock or concrete [6]

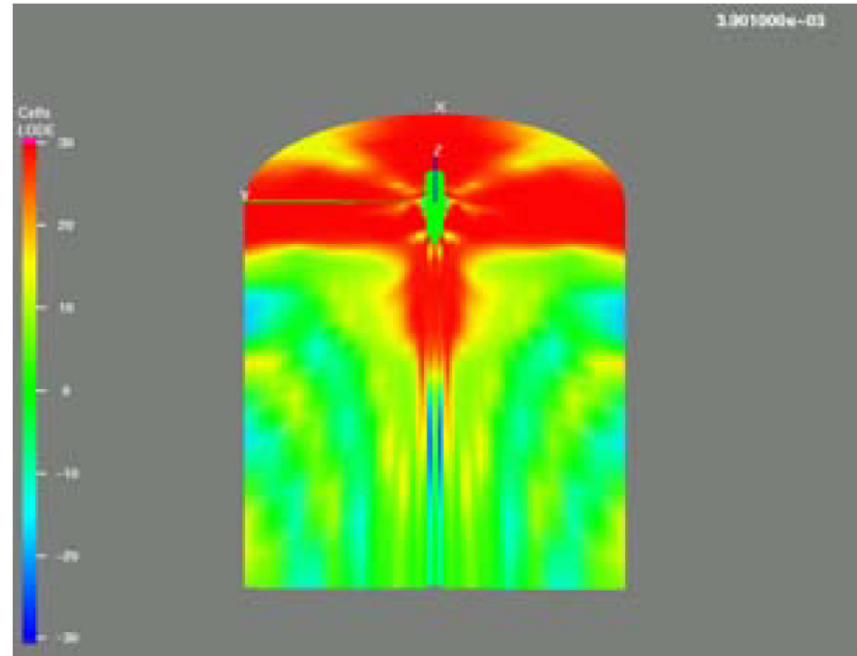
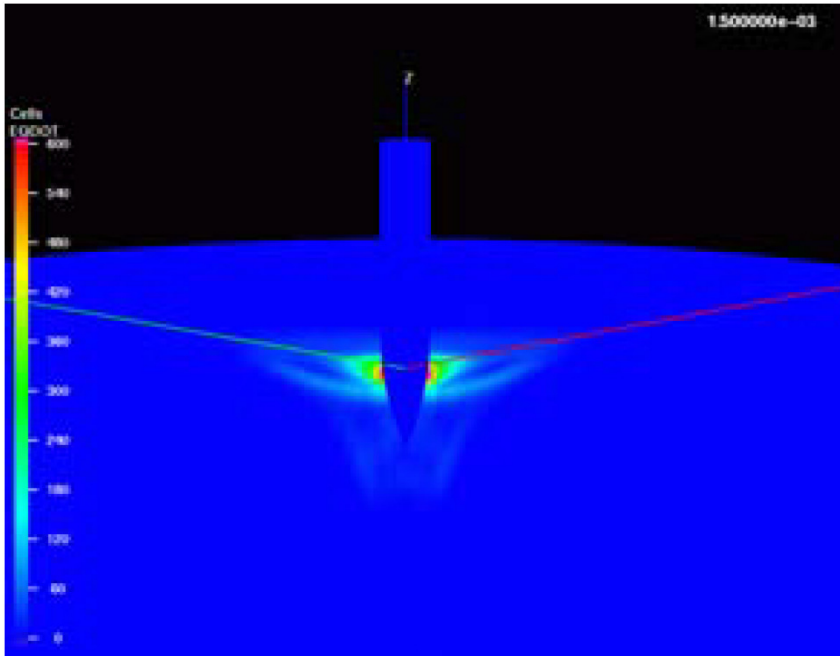

My work at Sandia: Electronics packaging designs

- Typical requirements
 - Volume constraint
 - Interface
 - Mounting features
 - Electrical connectors
 - Circuit board area
 - Mass properties
 - Weight, center of gravity
 - Inertia tensor
 - Design-for
 - Manufacture
 - (Dis-)Assembly
 - Environment
 - Ruggedness
 - Vibration, shock
 - Thermal

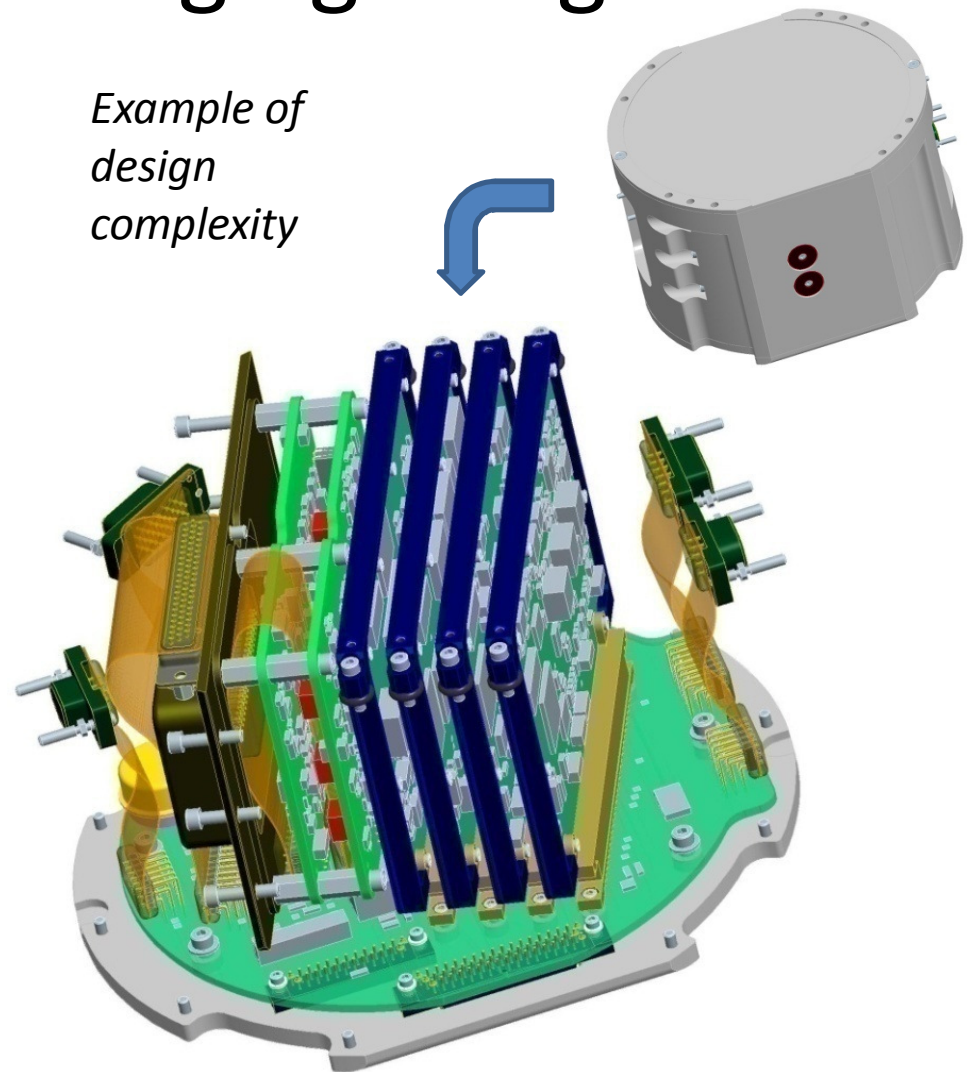

My research: FEA during conceptual design

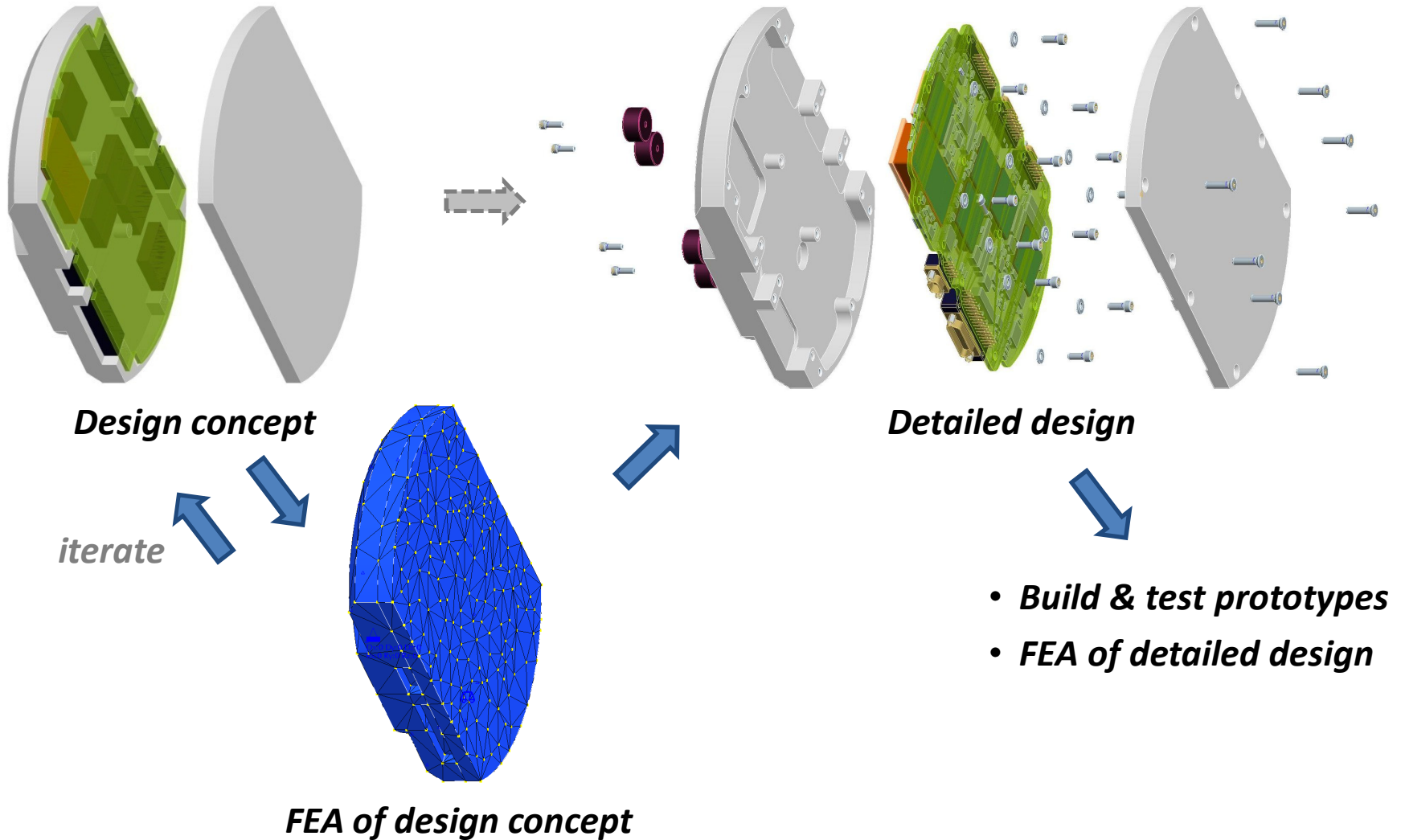

My research: FEA during conceptual design

- Develop simplified connector models
- FEA to support design decisions:
 - Quantity, geometry, mounting of circuit boards
 - Quantity, size, and location of electrical connectors

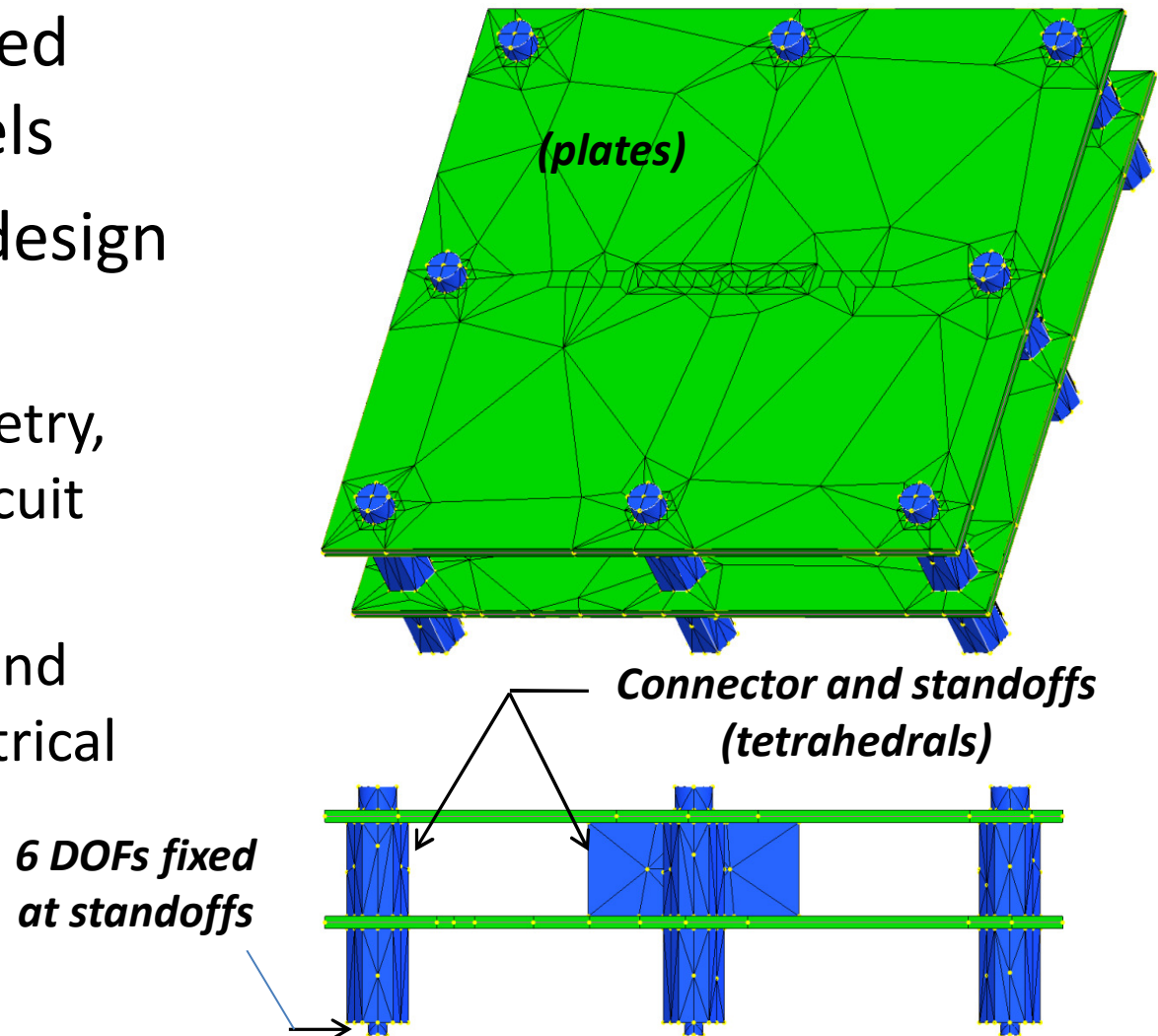

Roles & responsibilities

- Engineer
 - Responsible for product (system, component)
 - Oversees work by other team members
 - Interfaces with customer
- Designer (CAD)
 - Builds solid models and generates 2-D drawings
- Analyst (FEA)
 - Full-time analysis work

Model flow from CAD to FEA [7]

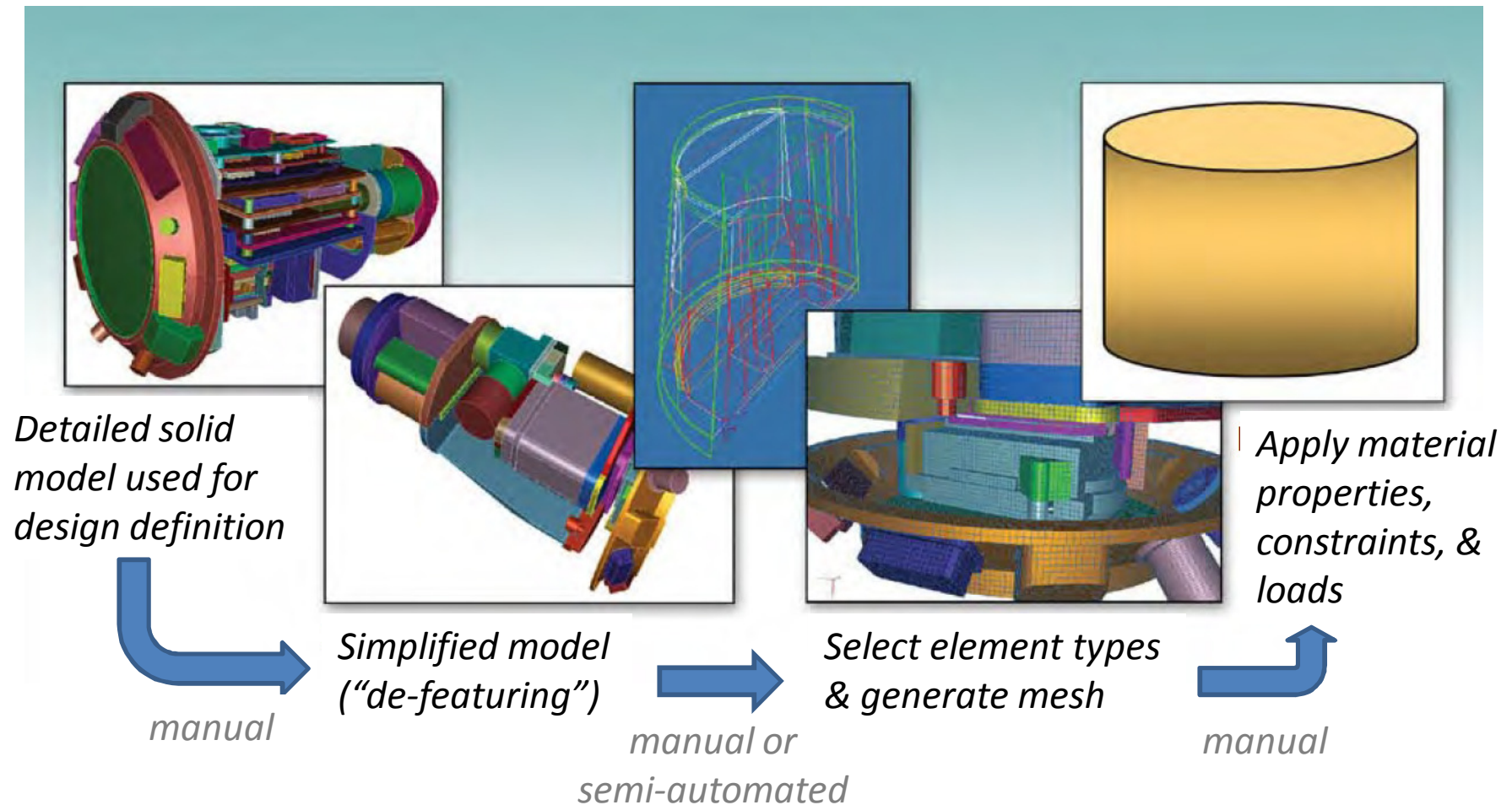

Overview of structural dynamics

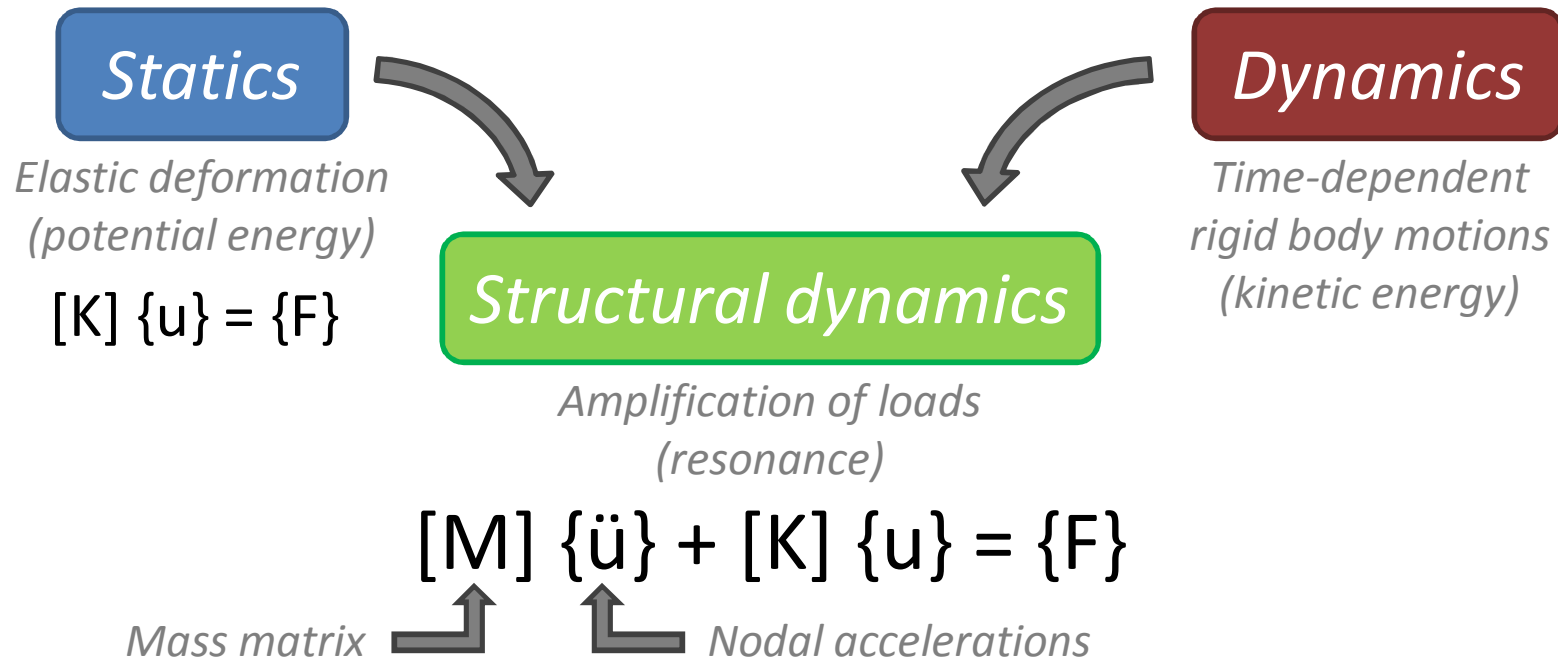

1st step: modal analysis

- Find resonant frequencies of structure
- Find displacement shape associated with each resonant frequency

Analysis of packaging designs

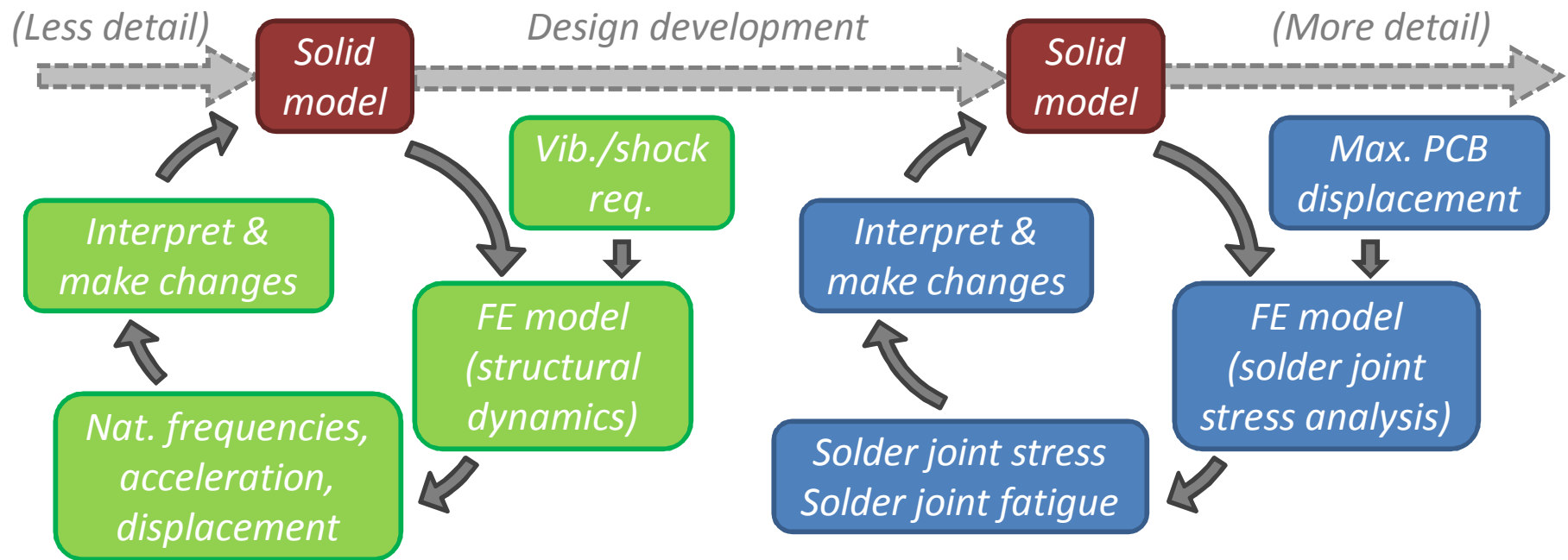

STRUCTURAL DYNAMICS

- Does not 'predict' failure
- Relies heavily on engineering judgment
- Does not require detailed PCB design

SOLDER JOINT STRESS ANALYSIS

- Goal is failure prediction
- Requires detailed PCB design

References

1. Laird, D., 2008, "NuMAD Blade Structural Analysis," *2008 Blade Workshop*,
<http://windpower.sandia.gov/2008BladeWorkshop/PDFs/Tues-16-Laird.pdf>
2. National Nuclear Security Administration Office of the Deputy Administrator for Defense Programs, "Defense Programs Strategic Vision for 2030," *DOE/NA-0011 Publications*,
<http://www.sandia.gov/ASC/pubs-media/pubs/dp-stratvision-2030.pdf>
3. Bhardwaj et al., 2002, "Salinas: a scalable software for high-performance structural and solid mechanics simulations," Proc. 2002 ACM/IEEE Conference on Supercomputing,
<http://portal.acm.org/citation.cfm?id=762790>
4. Hassan, B., 2002, "Sandia National Laboratories: Computational Aerothermodynamics," SAND2002-4206P,
<http://cobweb.ecn.purdue.edu/~aae519/hypersonic-s-news/sandia-aerothermo.pdf>
5. Plimpton, S., "Pronto – Transient Dynamics with Contact Detection,"
<http://www.sandia.gov/~sjplimp/pronto.html>
6. Fossum, A. C., 2006, "Rock Penetration: Finite Element Sensitivity and Probabilistic Modeling Analyses," SAND2004-3926,
<http://prod.sandia.gov/techlib/access-control.cgi/2004/043926.pdf>
7. Sandia National Laboratories, 2006, "Glimpses into Sandia National Laboratories' Advanced Simulation and Computing Program," SAND2006-6509P,
<http://www.sandia.gov/NNSA/ASC/pdfs/glimpses.pdf>