

Safeguards and Process Modeling for Molten Salt Reactors



PRESENTED BY

Nathan Shoman, Benjamin B. Cipiti (SNL), Benjamin Betzler (ORNL)

Global 2019

SAND***



- Motivations
- MSR Design Overview
- FliBe Flowsheet
- MSDR Flowsheet
- Safeguards tools

The goal of MPACT program is to address safeguards and security challenges for the DOE NE program

- Diverse landscape of MSR designs by domestic companies creates new safeguards challenges
- Due to renewed interest in MSRs, we began developing MSR safeguards tools in FY18.
 - Modeling architecture based on Separations and Safeguards Performance Model (SSPM) in MATLAB Simulink
 - The SSPM was originally developed for reprocessing plant safeguards modeling, including pyroprocessing
- Reactor and salt processing loops are modeled to approximate changing isotopics as a function of time

Three Types of MSR

- Liquid-fueled, drop-in design, with centralized salt processing

Modeling Focus ■ Cores are designed to be self-contained for ease of installation and replacement. This design shifts some of the accountancy requirements to a centralized facility.

- Liquid-fueled design with on-site salt processing
 - Salt processing on-site only removes fission products, but does not separate out actinides. Requires much less transportation of nuclear material at the expense of more accountancy challenges.
- Solid TRISO fuel elements (either pebble bed in MS or fixed assemblies)
 - Fixed assemblies would have no greater safeguards challenge than with LWRs. Pebble beds have the added complication of accounting of pebbles (though huge numbers need to be diverted for a significant quantity).

Reference Design – Flibe Energy Liquid-Fluoride Thorium Reactor (LFTR)

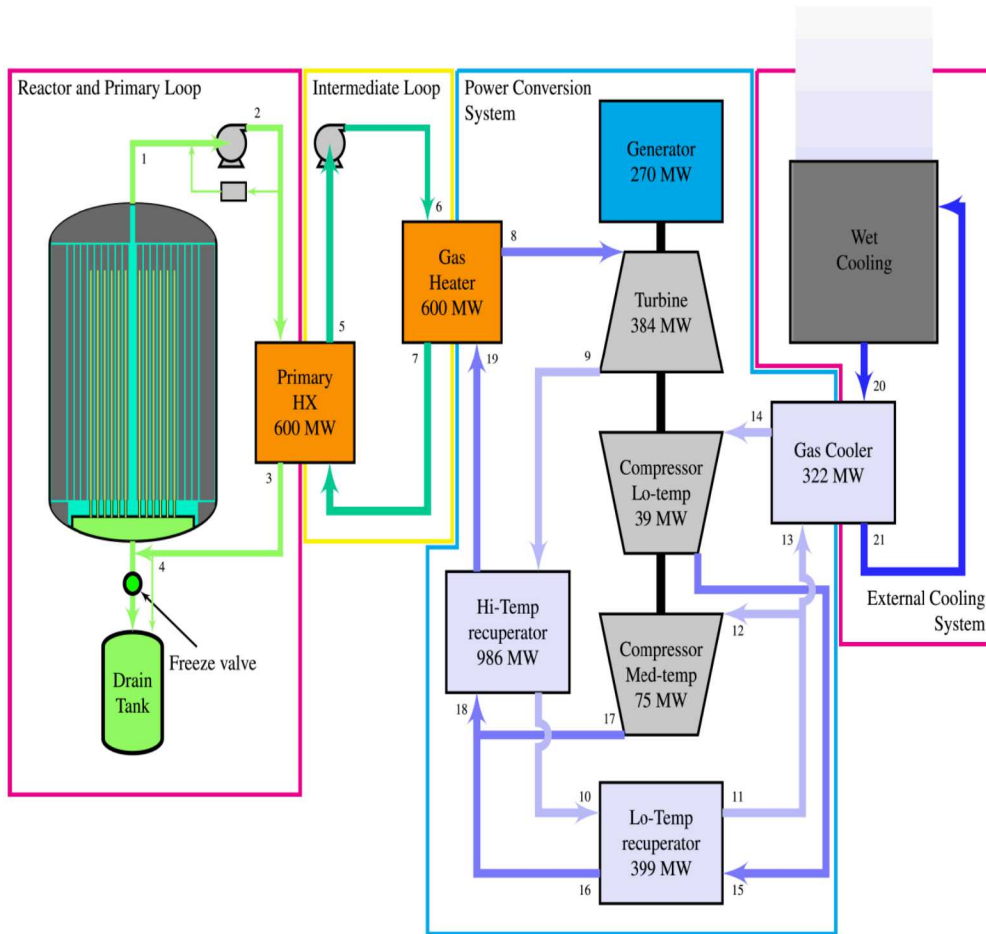

- Separate breeder and fuel salts
- Thorium fuel cycle
- Onsite salt processing
- 600 MW_{th} / 200MWe

LFTR Chemical Processing System

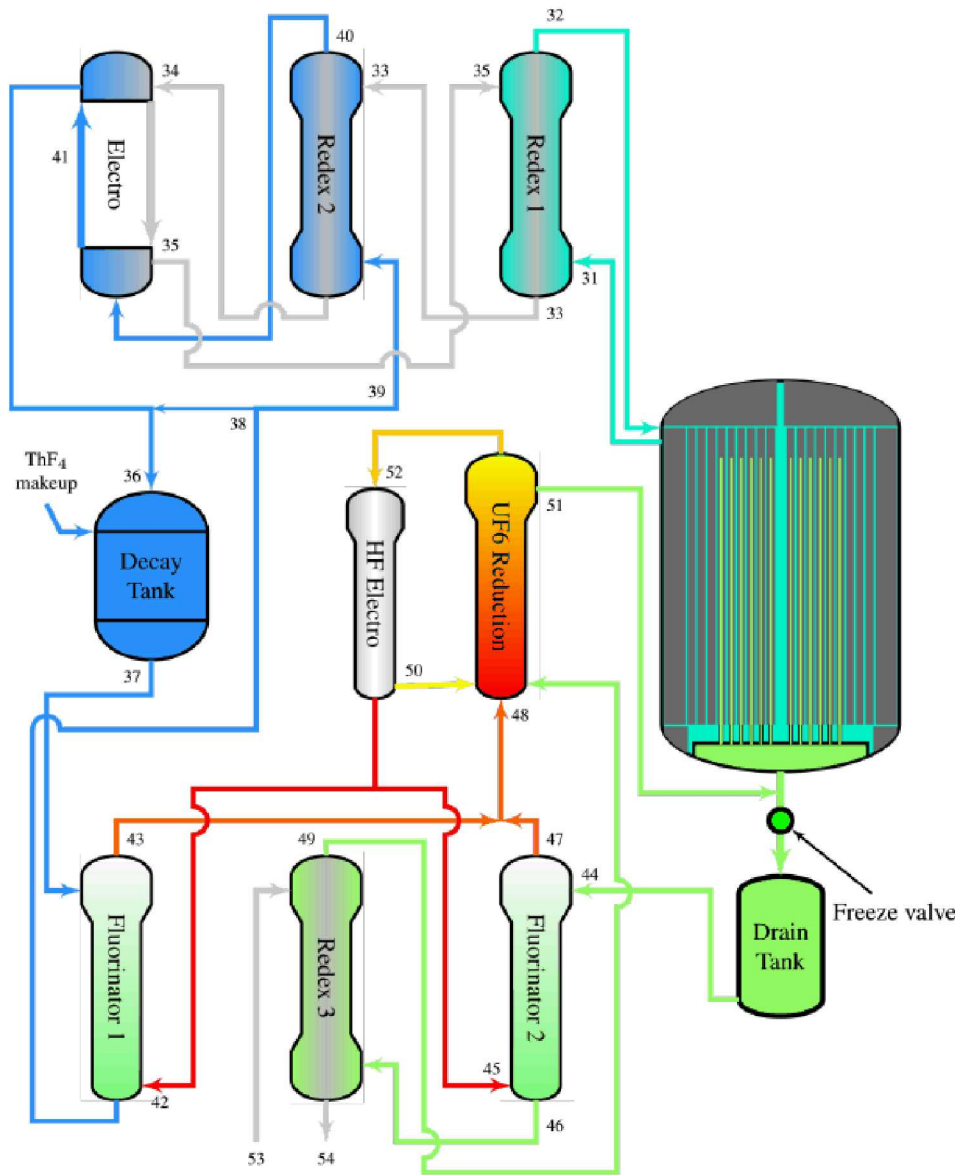

Fuel salt ~ 0.8 g/s.

Blanket salt ~ 380 g/s.

Metallic bismuth is used for the extraction processes.

The blanket contains Th to breed $^{233}\text{Th} \rightarrow ^{233}\text{Pa} \rightarrow ^{233}\text{U}$. The decay tank must hold the material for about 100 days to allow time for Pa-233 to decay. The ^{233}U is transferred to the fuel salt.

The fuel salt decays in the drain tank for about 30 days for short-lived species to decay. Then fission products are removed and ^{233}U is added.

7 Modeling Approach – Decay and Drain Tanks

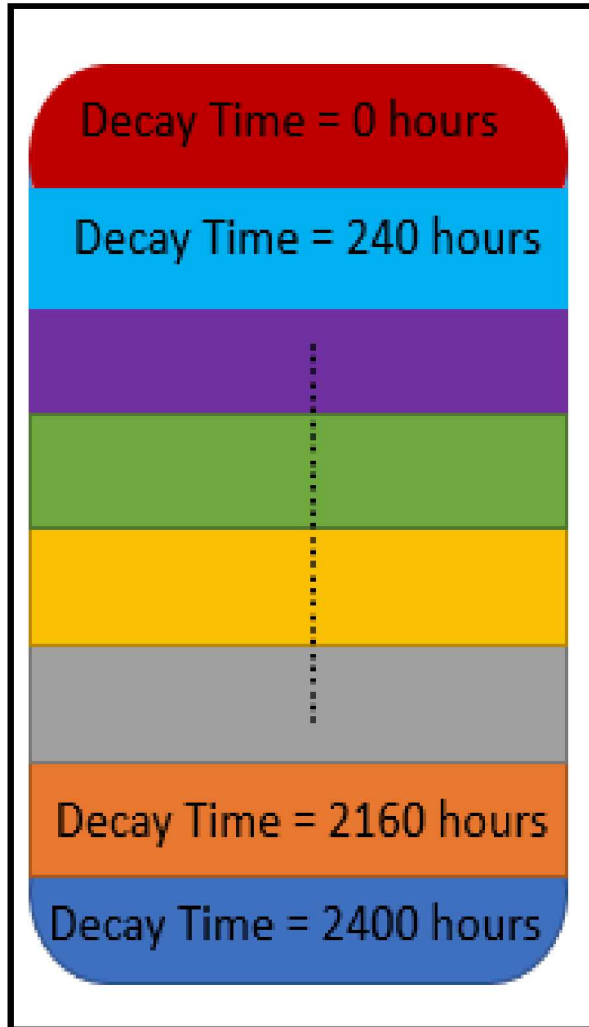

- Purpose is to allow protactinium to decay to uranium (blanket salt) or allow fission products to decay (fuel salt).
- The decay tank must let material decay for a specific amount of time, but the input material to the decay tank is changing due to constant core depletion.
- The decay tanks were discretized into 10 “slices”.

New Additions to FliBe Flowsheet for FY19

- Compensated for PHX holdup
- Explicit isotopic tracking (previously approximated via ratios)
- Improved start-up to steady state transition
- Implemented recycle loops (such as bismuth recycle stream on fuel salt loop)
- Resolved numerical errors for long run times

(Fuel Salt Loop)

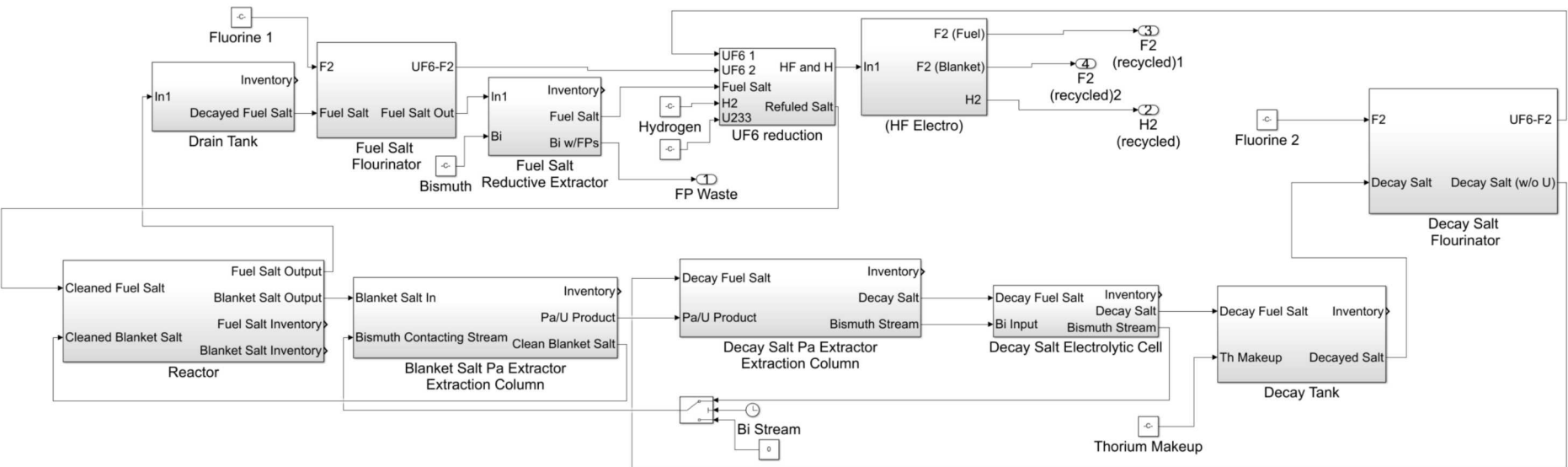

(Blanket Salt Loop)

Initial Results (Blanket Inventories)

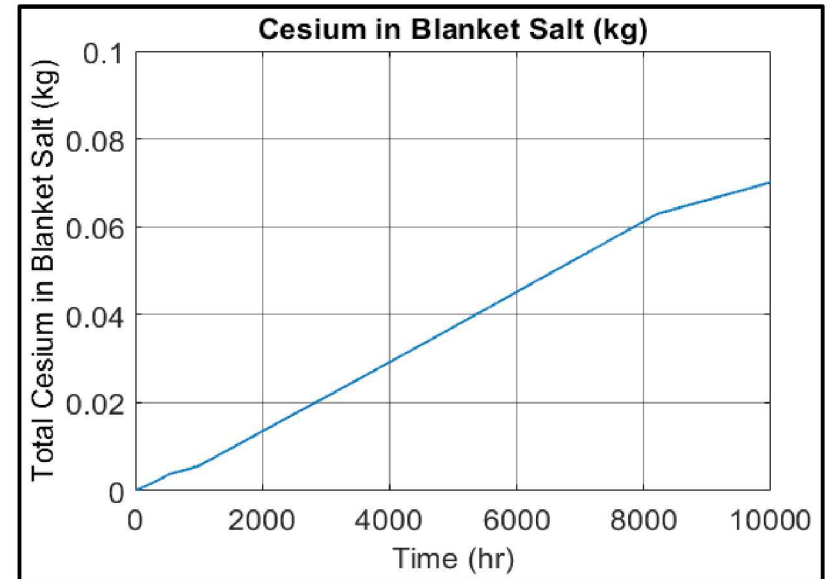
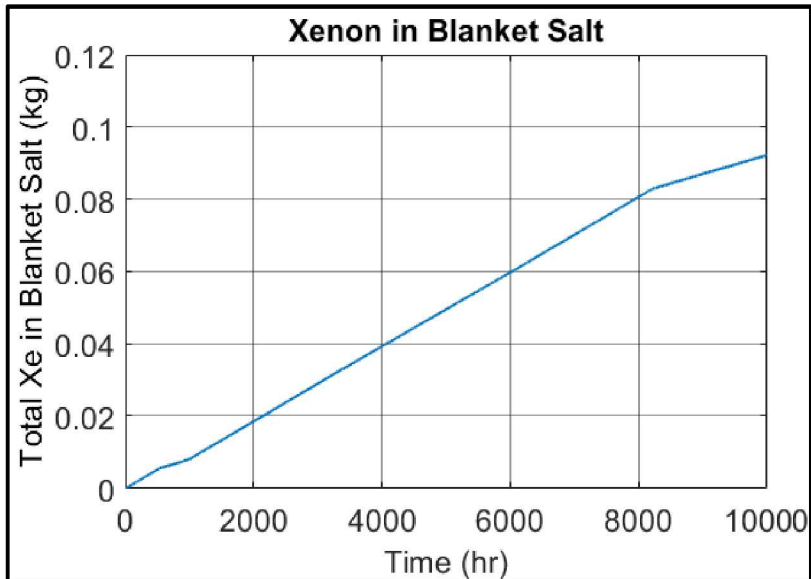
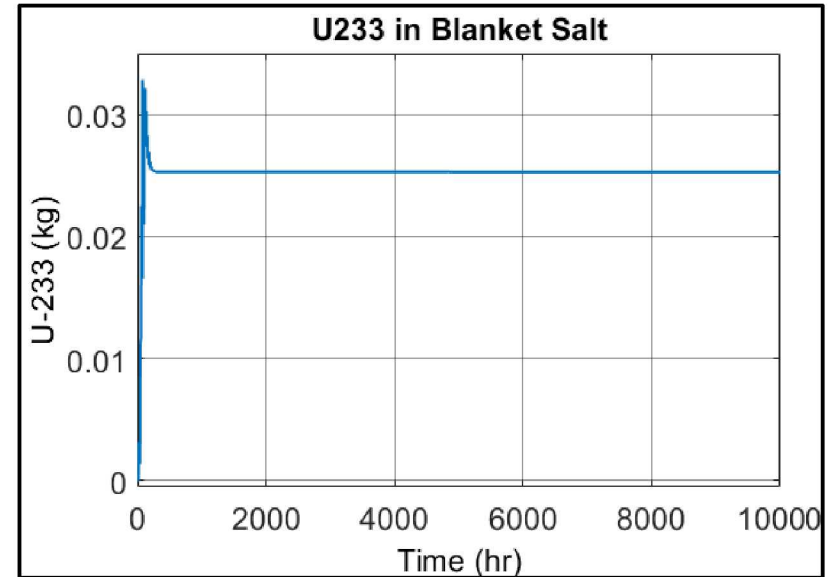
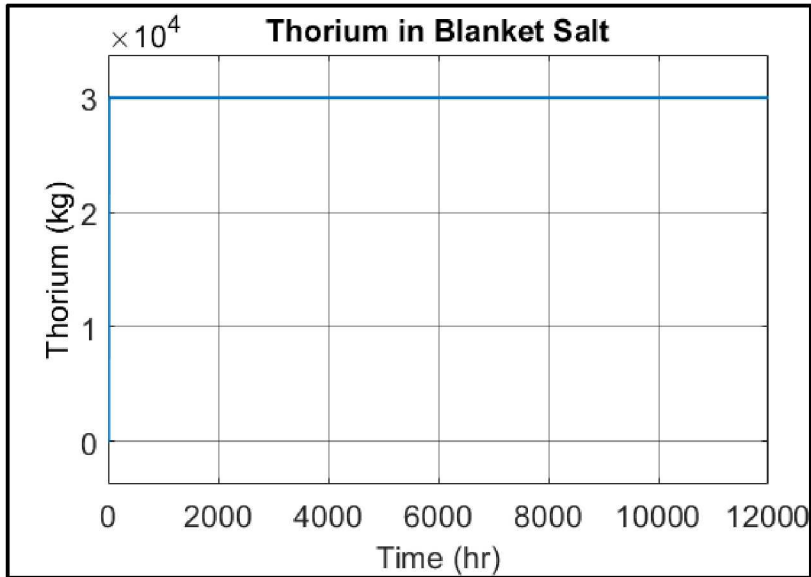

MSDR (Molten Salt Demonstration Reactor) Design

- Identified as MSR baseline design by ORNL
- Based on design in ORNL-TM-3832
- 350 MWe MSR inspired by MSRE
- Limited onsite reprocessing
 - Sparging of fission product gasses
 - Primary loop salt with soluble fission products replaced every 8 years

MSDR Plant Layout

ORNL DWG 72-3586

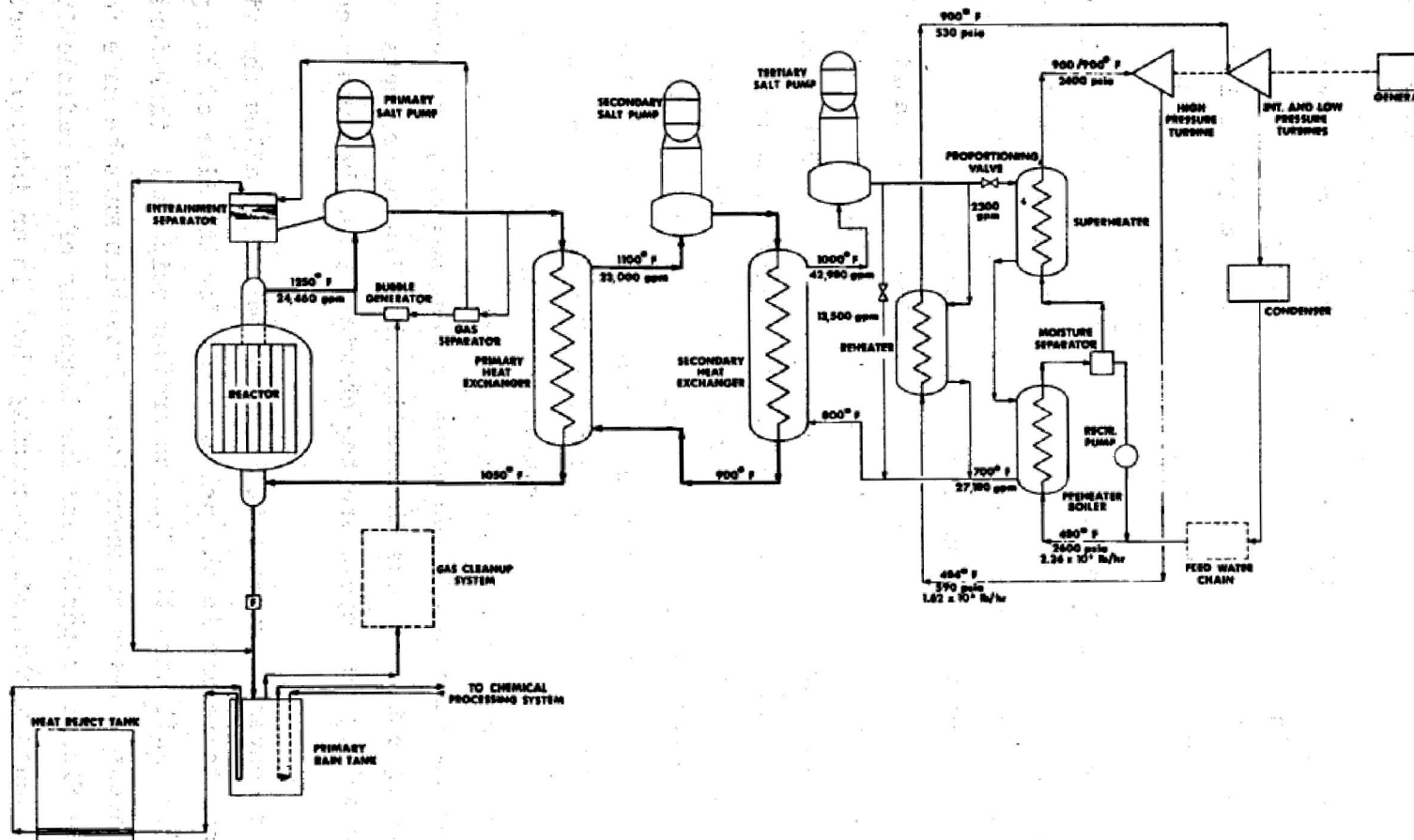

MSDR Flowsheet

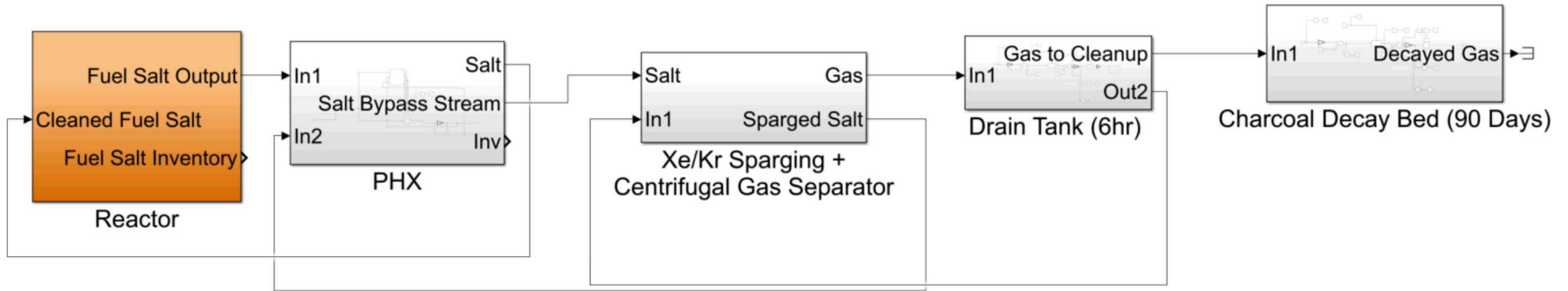

High fidelity TRITON model enables more accurate process model results

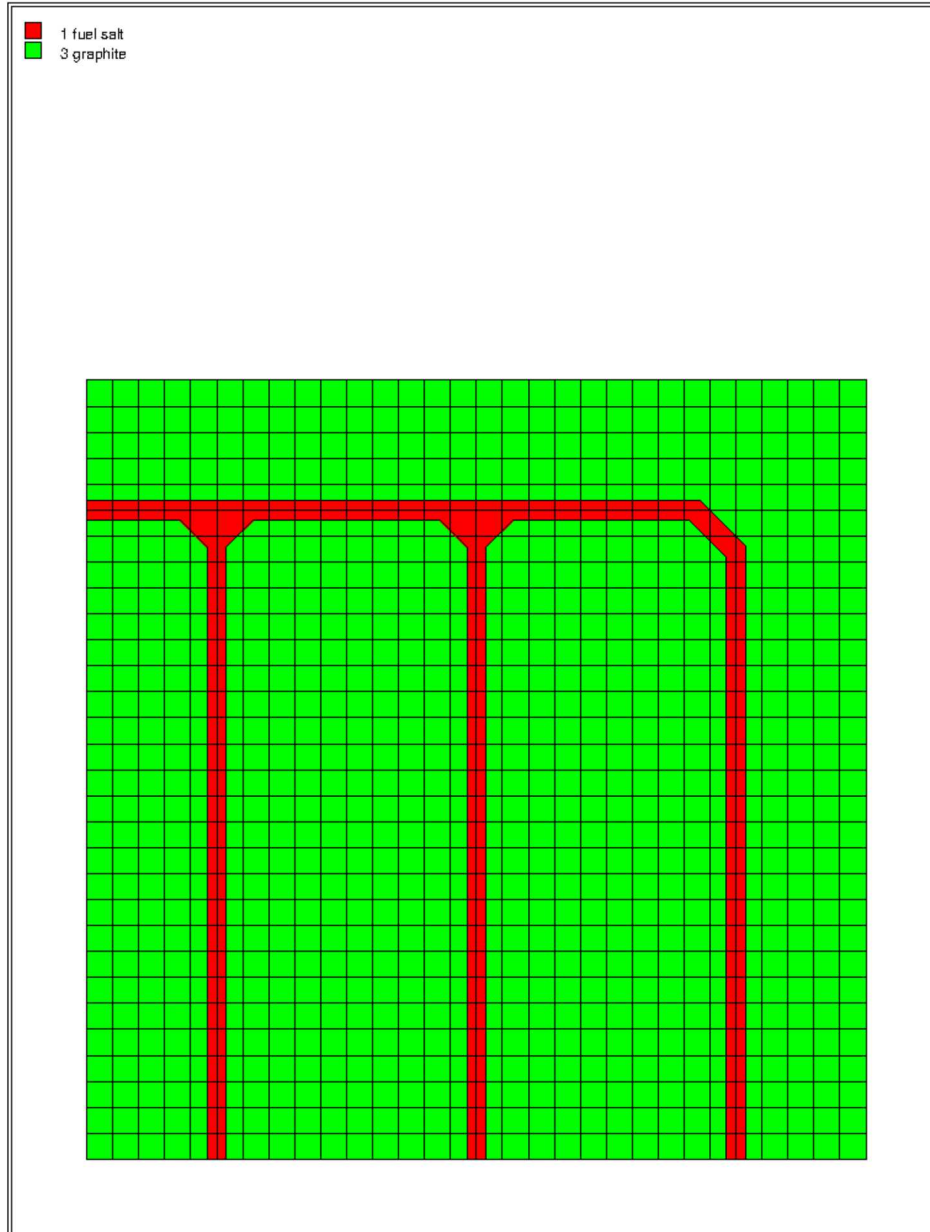

Safeguards Tools

- Separate tool from the process model
- General framework in MATLAB that allows use for any Simulink model
- Key characters in the MSR Simulink model are used to define material balance areas (MBAs)
- Computationally efficient
 - Only computes quantities of interest to user
 - Can calculate thousands of realizations with a few minutes
- Graphical capabilities to interpret large data series
- Includes several standard safeguards statistical metrics such as MUF, SITMUF, Page's trend test, and more
- Allows user to easily change measurement uncertainties

MSR Safeguards Tools Enable Generalized Measurements Across any MSR Flowsheet

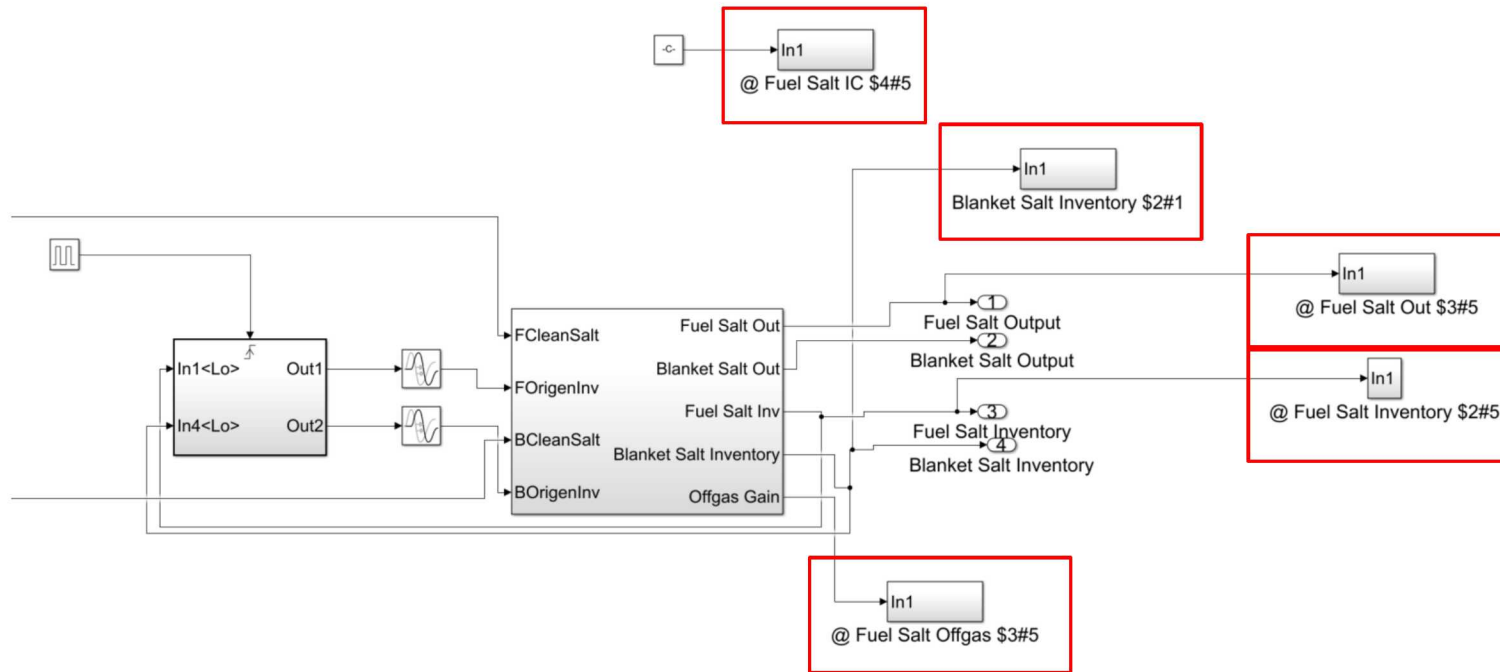

Modifications of measurement uncertainties easily changed through GUI

The image displays a software interface for managing measurement uncertainties, titled "MSRS1". The main window is divided into four panes: "Safeguards Data Sources", "Random Uncertainties", "Systematic Uncertainties", and "Controls".

- Safeguards Data Sources:** Contains three input fields with values 3, 3, and 5.
- Random Uncertainties:** Contains three sections labeled "All", "Inventory Terms", and "Outputs", each with "Uniform" and "Variable" buttons.
- Systematic Uncertainties:** Contains three sections labeled "All", "Inventory Terms", and "Outputs", each with "Uniform" and "Variable" buttons. The "Variable" button in the "All" section is highlighted with a red dashed box.
- Controls:** Contains "Summary Table" and "Continue" buttons.

A red line connects the highlighted "Variable" button in the "Systematic Uncertainties" pane to a secondary window titled "MSR_varPane". This window provides a detailed view of the uncertainty settings for various inputs:

- Input:** A section with a "Done" button at the bottom.
- Fuel Clean Salt Input:** Four dropdown menus, each set to "0.1%".
- FSRE Salt Input:** Four dropdown menus, each set to "0.1%".
- FSRE Bi Input:** Four dropdown menus, each set to "0.1%".
- Additional Inputs:** Two more rows of four dropdown menus each, all set to "0.1%".

Simple GUI interface allows for multiple safeguards metrics to be calculated in the same step

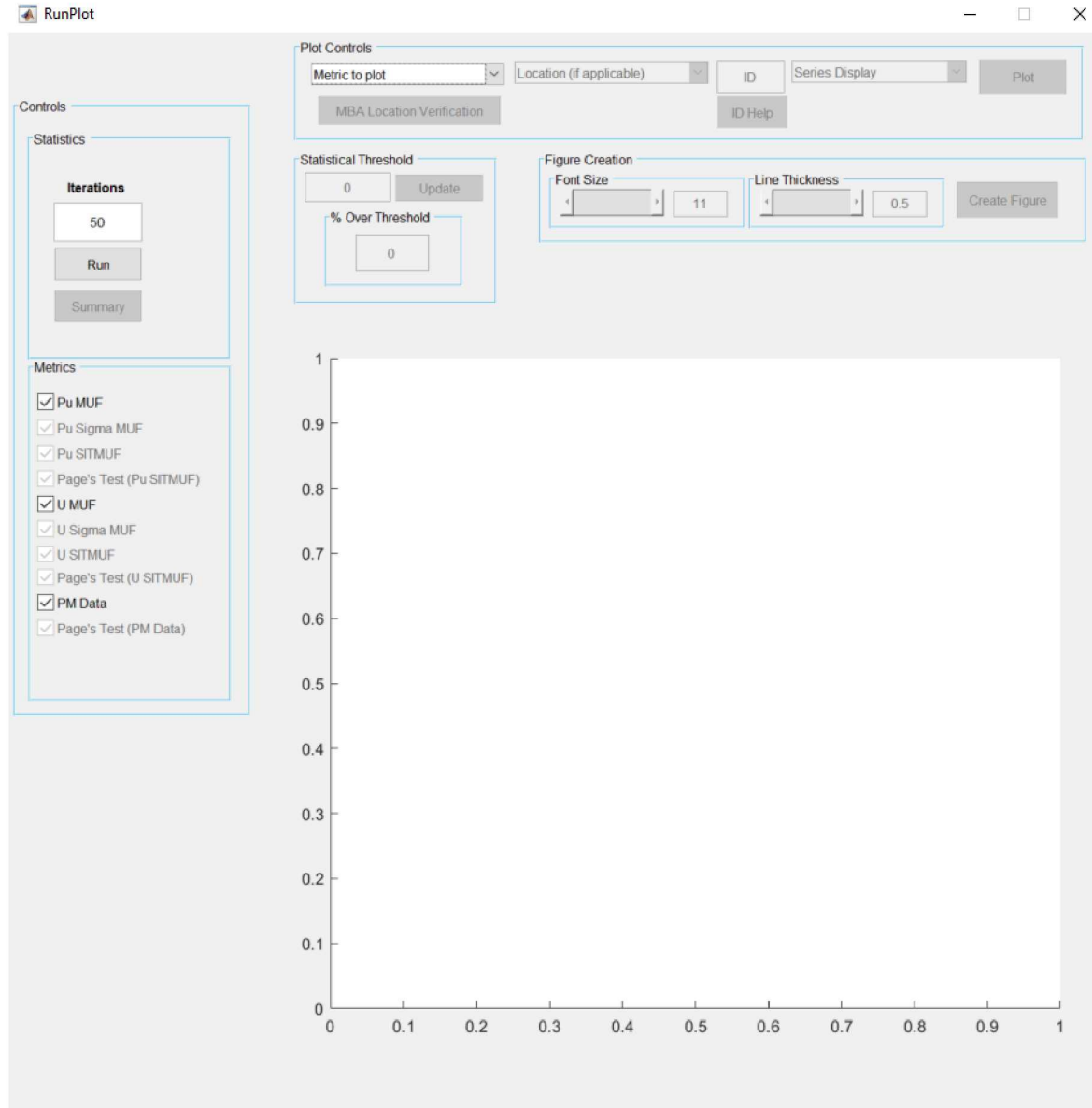

Utility allows for checking of process data

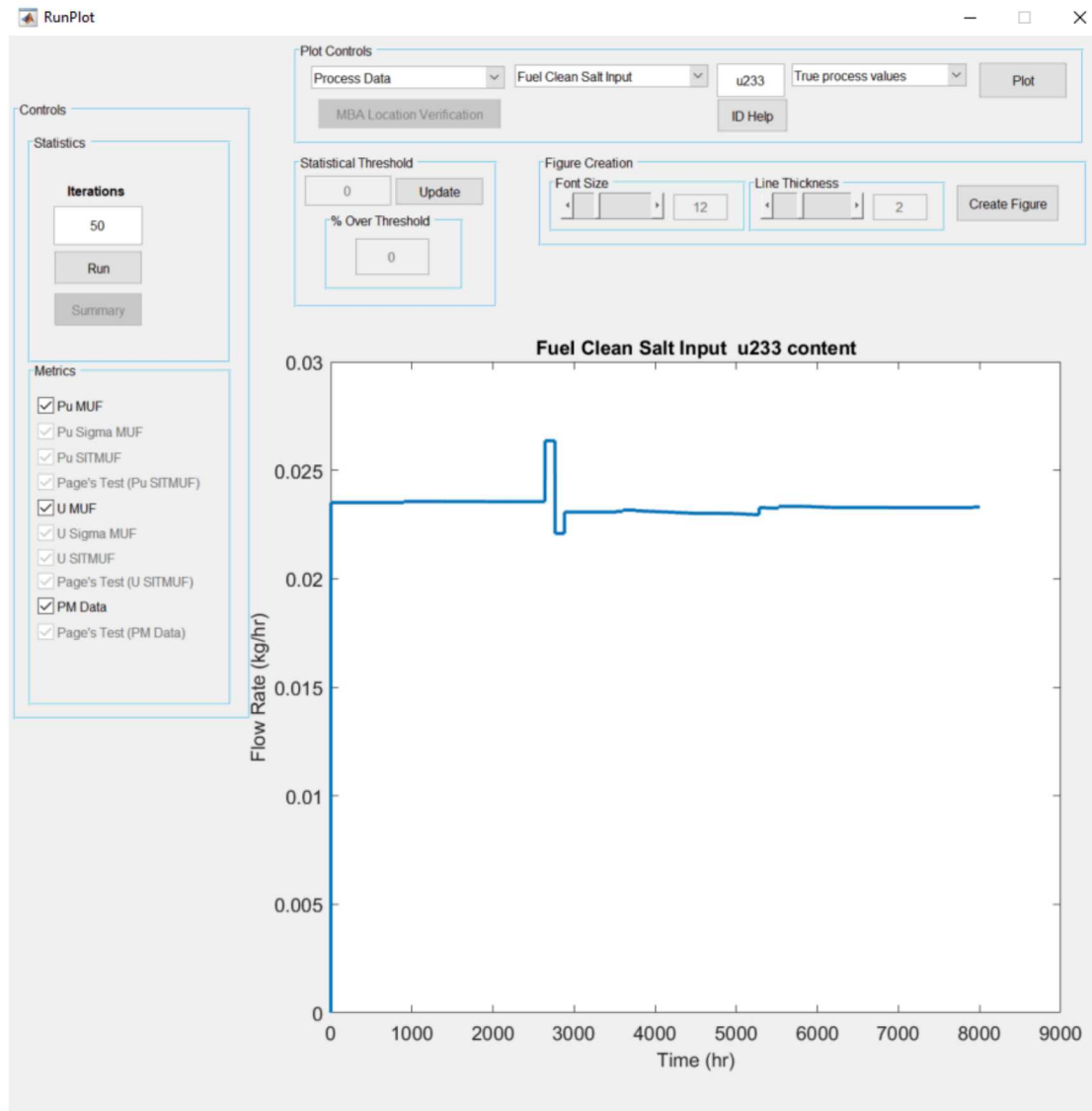

Calculation of common safeguards metrics like SITMUF

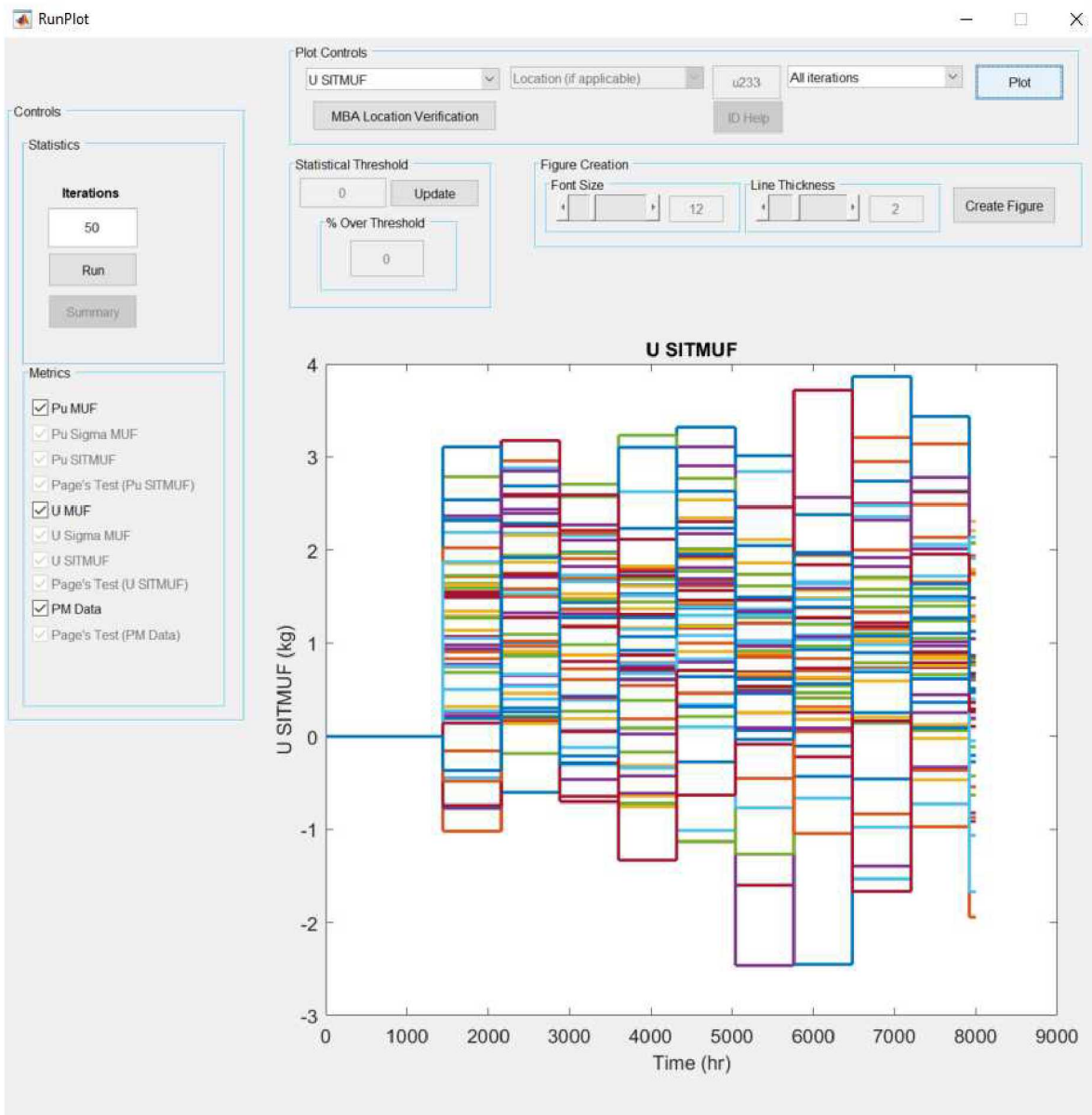

Can easily implement thresholds for various statistical tests like Page's test

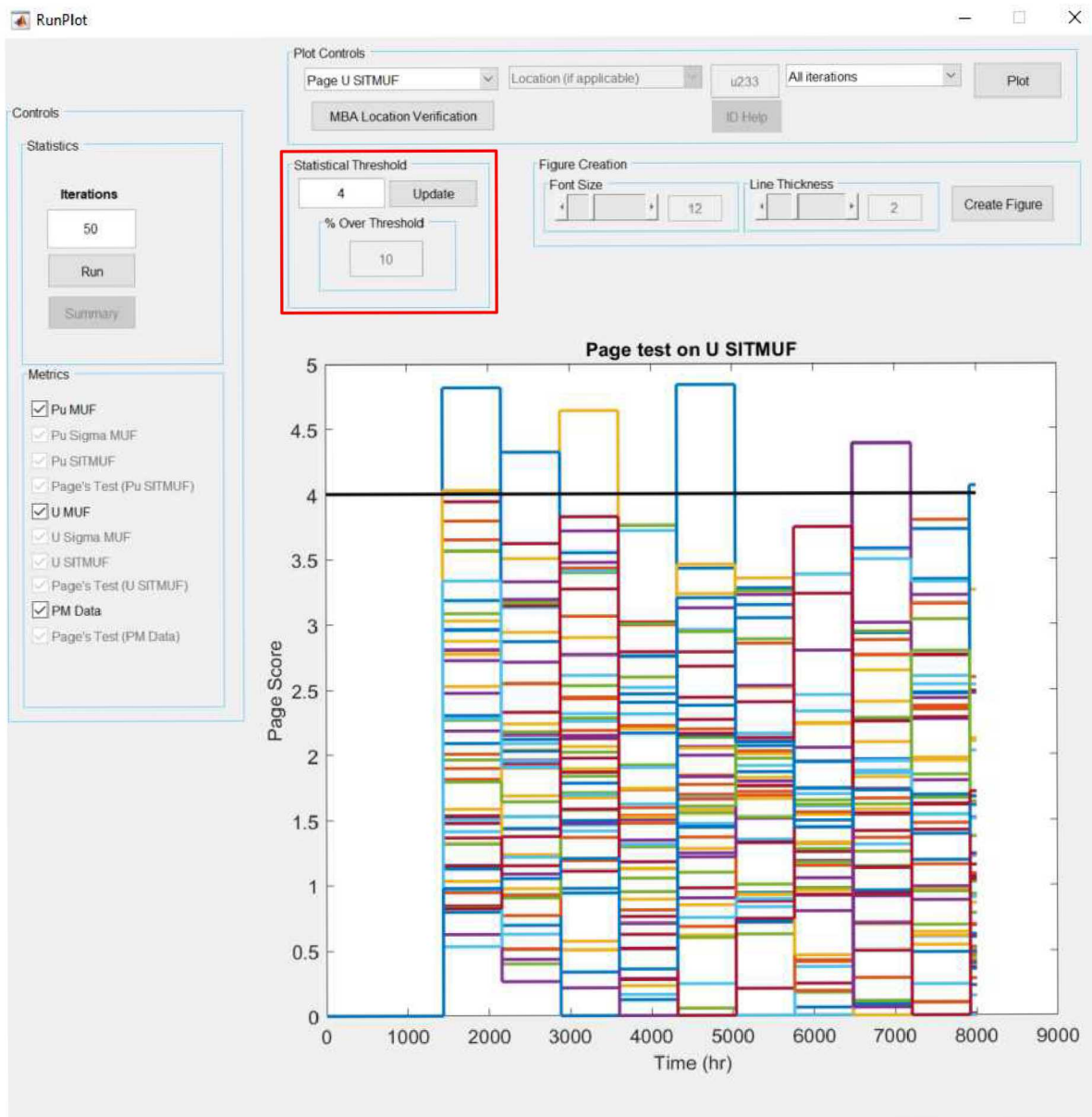

Ongoing / Future Work

- Safeguards analysis of both FliBe and MSDR flowsheets
- Improvement to MSDR reactor model with TRITON
- Evaluation of advanced process monitoring for MSRs

The authors would like to acknowledge the Department of Energy's Office of Nuclear Energy for funding this work through the Material Protection, Accounting and Control Technologies (MPACT) campaign.

Sandia National Laboratories is a multimission laboratory managed and operated by National Technology and Engineering Solutions of Sandia LLC, a wholly owned subsidiary of Honeywell International Inc. for the U.S. Department of Energy's National Nuclear Security Administration under contract DE-NA0003525.