

Laboratory Building Systems

Student Guide





Note to printer



The majority of this document is intended for printing double sided on 8 ½" x 11" or A4 paper however there are drawings at the end which should be printed at 11"x 17" single sided.

Also note that the 11"x17" portion includes both vertical and horizontal layouts.



Introductions

- Instructors
- Students
 - Your name?
 - Where are you from?



Slide 2

Action Plan

By the end of this lesson, I would like to:

KNOW		FEEL		BE ABLE TO DO	
------	--	------	--	---------------	--

Your learning doesn't stop with this lesson. Use this space to think about what else you need to do or learn to put the information from this lesson into practice.

What more do I need to know or do?	How will I acquire the knowledge or skills?	How will I know that I've succeeded?	How will I use this new learning in my job?

Use space on back, if needed



Key Messages

- Laboratories have unique requirements that influence virtually all building system designs.
- Planning to accommodate the appropriate space for building systems is an essential part of the design process.
- Mechanical systems play a critical role in any lab where containment of biological agents or toxins is a concern.
- Plumbing systems also often play a role in preventing the release of biological agents from a laboratory.
- The distribution and zoning of all building systems must consider biological safety issues.
- System redundancy must be considered wherever building systems are relied upon as part of the biological containment or biosecurity system.



Page 4

Notes:

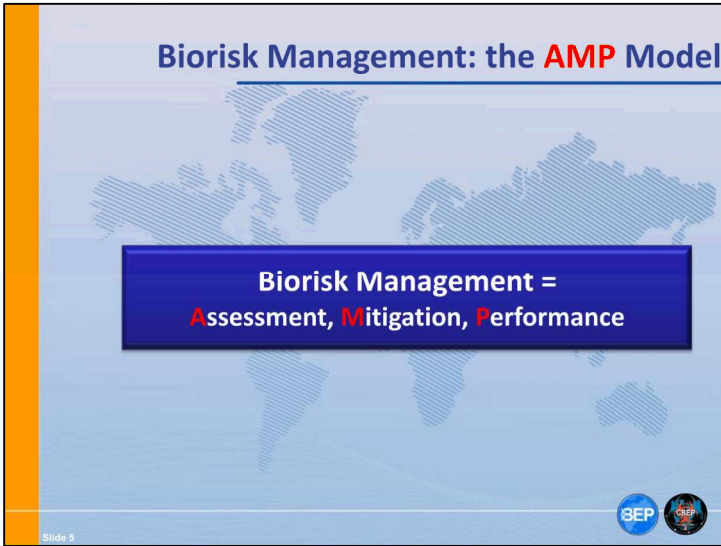



Notes:

Key Components of Biorisk Management

 **Biorisk Assessment**

- Process of identifying the hazards and evaluating the risks associated with biological agents and toxins, taking into account the adequacy of any existing controls, and deciding whether or not the risks are acceptable





Slide 6

Key Components of Biorisk Management

 **Biorisk Mitigation**

- Actions and control measures that are put into place to reduce or eliminate the risks associated with biological agents and toxins



Slide 7

Key Components of Biorisk Management

Performance

- The implementation of the entire biorisk management system, including evaluating and ensuring that the system is working the way it was designed. Another aspect of performance is the process of continually improving the system.



Slide 8



Laboratory Building Systems

This course is designed to aid in Biorisk Management by promoting good bioscience lab design practices.

Slide 9



Laboratory Design Process

Containment barriers and the spaces and equipment used to move people and materials across.

The diagram illustrates a laboratory layout. On the left, a detailed view shows an 'Ante Room' and a 'Lab' connected to a 'Sterilizer'. A stick figure holding a biohazard sign is positioned in front of the lab. To the right, a larger floor plan shows a red-outlined containment area within a larger building layout. Logos for 'BEP' and 'OSBP' are visible at the bottom right of the slide.

Notes:

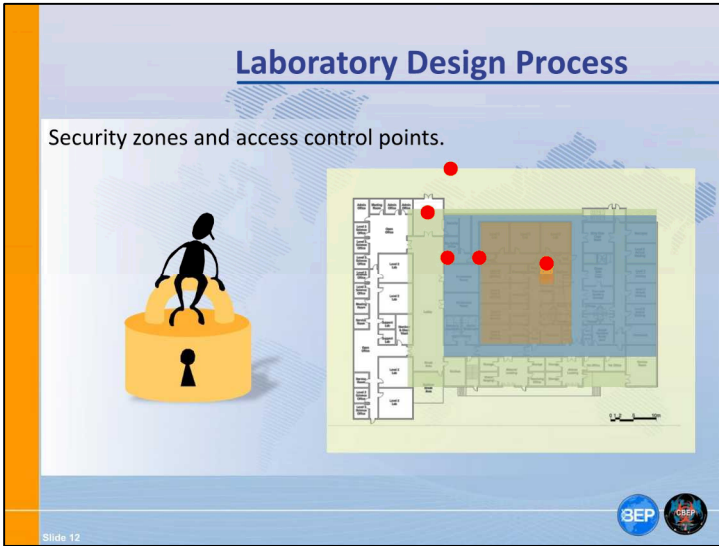

Notes:

Laboratory Building Systems

- Today we will briefly discuss:
 - Structural Systems for Laboratories
 - Architectural Systems for Laboratories
 - Mechanical Systems for Laboratories
 - Plumbing Systems for Laboratories
 - Electrical Systems for Laboratories



 

Slide 13

Notes:

Building Systems - Structural

- Structural systems are comprised of:
 - Columns
 - Beams
 - Walls (bearing, shear)
 - Floors & Roofs
 - Foundations
- Laboratories may utilize any type of structural system (concrete, steel, wood, hybrids) however some types have distinct advantages



Slide 14

Notes:

Building Systems - Structural

Class Activity:

Questions - What are the factors that affect the choice of **structural system** for a laboratory?

What are the factors that will affect the layout of the **structural grid**?

Slide 14



Notes:

Structural Grid

Ideal Grid Spacing

- Lab ergonomics require 1.5m clear between equipment and benches
- Minimal room or lab bay 3.1m clear
- 6.2-7.0m grid spacing for double bay (depends upon wall construction & equipment)

Slide 15

Structural Grid

Align Lab & Structure

- Ensures functional lab layouts can be developed now and modified in future
- Allows for good organization of lights, diffusers, mechanical and plumbing penetrations

Slide 16

Structural Systems

Individual Activity:
Spend **5 minutes** reflecting upon the structural system serving a lab you are familiar with.

Questions?

- How does the system help to mitigate biorisk?
- Are there biological safety risks inherent in this system?
- Are there biological security risks inherent in this system?

Slide 16





Notes:

Building Systems - Architectural

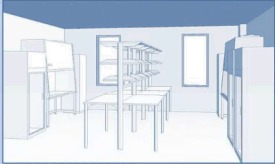
- Architectural systems are comprised of:
 - Walls
 - Floors
 - Ceilings
 - Doors & Windows
 - Casework
 - Finishes
- Type of lab, activities and risks within will influence the choice of architectural systems



Slide 18



Notes:

Building Systems - Architectural

Building Systems Example Laboratory Plan

Slide 20

BEP

Notes:

Building Systems - Architectural

Class Activity:

Which spaces in the facility will be exposed to some type of **biological risk**?

How can the architectural materials in these spaces help to **mitigate risks**?

Slide 21



Building Systems - Architectural

- Guidance on the appropriate finish and construction materials can be found in:
 - **Biosafety guidelines**
 - **Institutional standards**
 - **Precedents**, similar labs in a similar environment



Slide 22

Guidelines

- Often guidelines prescribe the *performance criteria* of finishes, services and construction for different lab types without specifying an exact material or system.

“Walls, ceilings and floors should be smooth, easy to clean, impermeable to liquids and resistant to the chemicals and disinfectants normally used in the laboratory. Floors should be slip-resistant..”

“Bench tops should be impervious to water and resistant to disinfectants, acids, alkalis, organic solvents and moderate heat.”

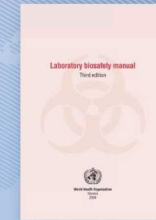

Slide 23

Building Systems - Architectural

- ***Basic principles***
 - Don't support growth of biological agents
 - Don't absorb toxins
 - Allow for easy cleaning (material and form)
 - Stand up to disinfectants
 - Withstand wear and tear of intended function
- ***Criteria more stringent with increased risk***
 - Stand up to gaseous decontamination
 - Form an appropriately tight containment barrier

Slide 24



Notes:

Space for services

- Space for lab services also depends upon risk.



What risks are posed by the air and liquids leaving the lab?



Slide 25

Notes:

Space for services

Group Activity:

In your groups spend **20 minutes** reviewing and discussing the **3 laboratory scenarios**.

Select the **building section** drawing most appropriate for the labs described in each scenario.

Make note of any **questions** you have for the facility clients that would help you to determine the right solution.



Slide 26

Building sections

How much space do you need?



Slide 27

Laboratory scenarios

Laboratory A is an animal disease diagnostics facility. This laboratory receives a variety of diagnostic samples which may range from fecal matter, blood, tissue and in some cases full carcasses of small animals. The laboratory tests these samples for a wide range of diseases and in many cases is working to determine the cause of illness or death of animals found in the wild. Many of the diseases this lab works with are dangerous to animals only, however some are zoonotic diseases, which pose a risk of serious disease in both animals and humans. Users in this laboratory change out of their street clothes and don lab greens in a general change area, then enter the lab via an ante room where they put on disposable coveralls, positive pressure respirators, gloves and shoes dedicated to the laboratory. Upon exiting the lab all personnel protective equipment is removed and disposed of except the respirator which is wiped down with disinfectant and stored in the ante room for re-use. All waste leaving this lab is removed via a pass through sterilizer connected directly to the laboratory.

Laboratory B is a diagnostics lab. The laboratory receives well packaged blood samples from a nearby hospital and tests these for a list of known diseases. Samples are examined inside biosafety cabinets. Lab users wear laboratory coats over their street clothes, disposable gloves and N-95 respiratory protection when working at the biosafety cabinets. Lab users remove their lab coats and disposable gloves at the laboratory exit and wash their hands prior to exiting. All waste from the labs is sterilized in a common use sterilizer outside of the laboratory prior to removal from the facility.

Laboratory C is a large animal vaccine testing laboratory. This lab houses large animals, usually cattle held in open air pens within the animal holding room. The animals have been vaccinated then exposed to a known disease and are held and tested to determine the efficacy of the vaccine. The disease in question poses no threat to humans but is of very high consequence to livestock. Users wear gloves, boots, re-usable coveralls and enter and leave the lab via a change room with shower. All waste removed from the room is taken out via a dirty corridor to a common use sterilizer.

Space for services

Concept Section 1 - Lab with ceiling plenum

Ductwork distributed in ceiling space

Valves accessible from adjacent corridor

Drainage piping buried or distributed in ceiling space of floor below

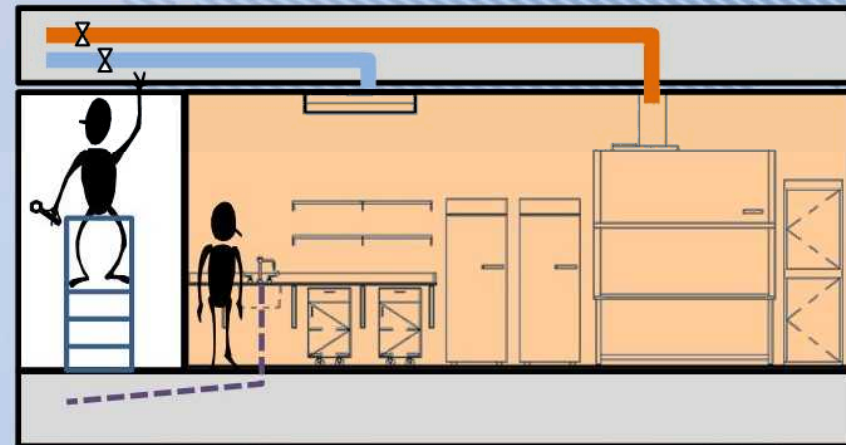

Space for services

Concept Section 2 – Small mechanical space above

Space above or beside lab for HEPA filters and access to valves

Ductwork distributed in ceiling space

Drainage piping buried or distributed in ceiling space below



Space for services

Concept Section 3 Service spaces above and below

Large dedicated space above the lab for HEPA filters and controls.

Effluent treatment system below with space for inspecting laboratory waste piping

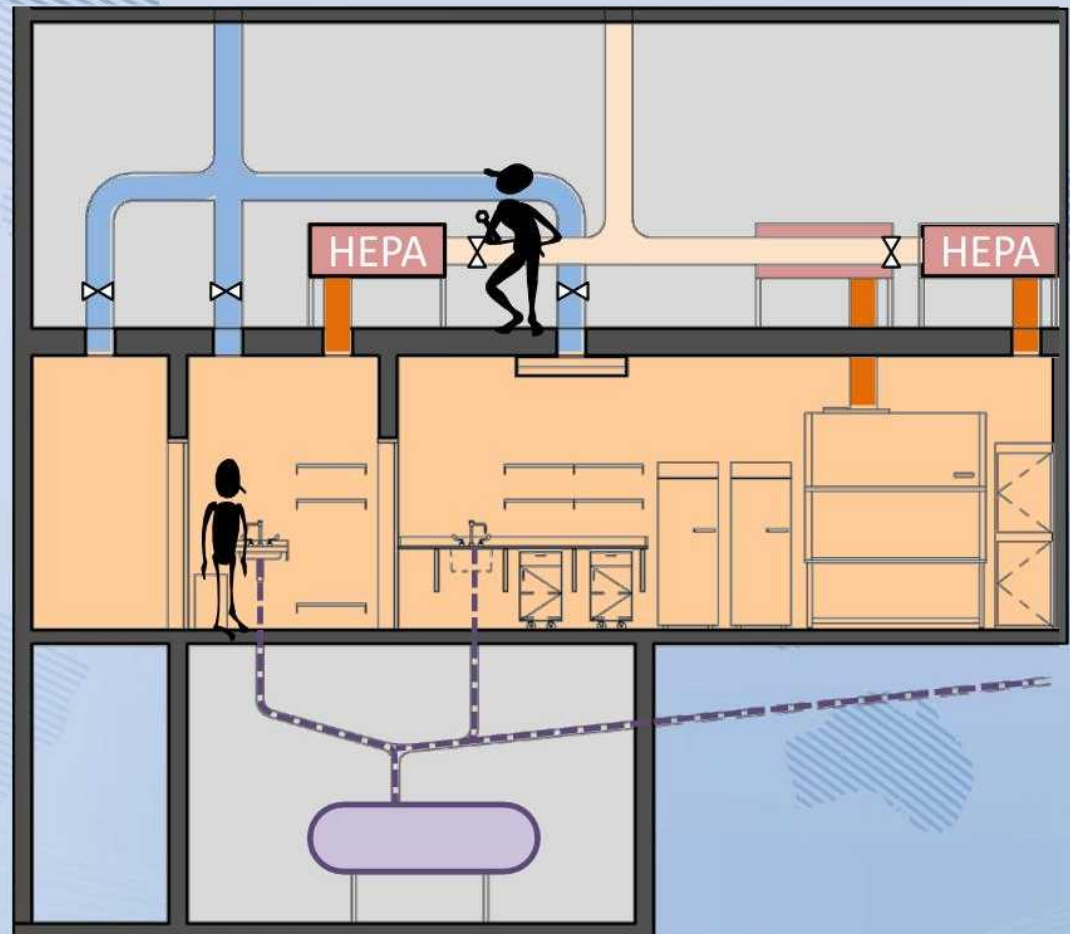



Building Systems

Individual Activity:

Please spend **10 minutes** reviewing the drawings of the **'Building Systems Lab'** found at the back of your student guides.

Think about the mechanical, electrical and plumbing systems and spaces that may required to support the labs.

Slide 32



Building Systems

Class Activity:

Questions - What are the mechanical, electrical and plumbing **systems** required to support the general labs, containment labs, and animal areas?

What **spaces** are required to house these?

Slide 34



Notes:



Mechanical Systems

- Controlling the flow of air in and out of the laboratory is an essential part of all biocontainment strategies.

Main components are:

- Air Handling Units (AHUs)
- Exhaust Fans
- HEPA filters
- Ductwork and controls which interconnect the above elements

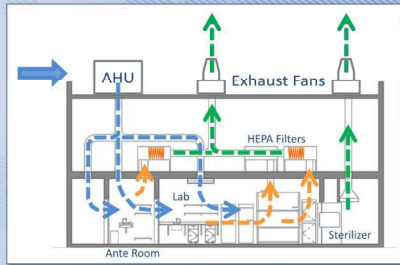

Notes:

Mechanical Systems

Group Activity:

In your group spend **45 minutes** discussing and developing a **conceptual layout** for **air handling units, exhaust fans & HEPA filters** as required to serve the general labs & containment labs.

Make note of any **questions** you have for the stakeholders that would help you to design the system.



Slide 39

Notes:

Mechanical Components

- Component sizes

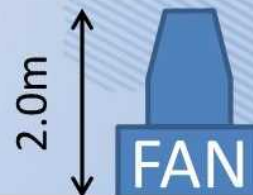
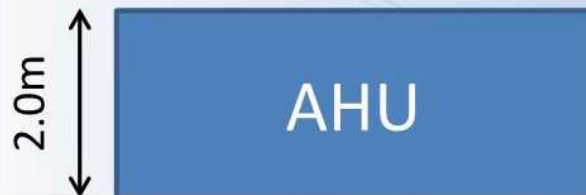
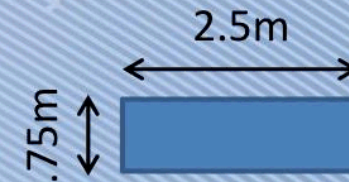
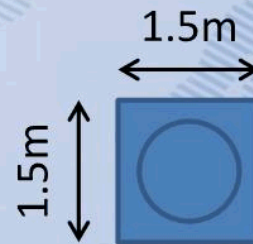
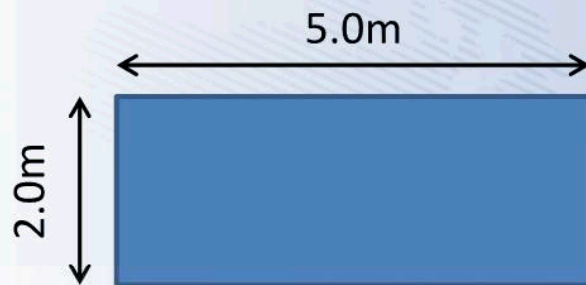

- For concept design purposes assume these sizes

Zoning and Decontamination

- **Decontamination**
Laboratories may be set up for decontamination individually or in groups
Zones will affect placement of filters and/or control valves



Slide 44



Notes:

Zoning and Decontamination

- **Decontamination**
 - Grouping labs may not interfere with operations
 - Allows for ganging of HEPA filters and simpler controls
 - Ante/Fumigation rooms need separate control
 - Agent storage areas may need to run 24/7



Slide 42



Notes:

Zoning and Decontamination

- **Decontamination**
 - Animal areas may require frequent decontamination
 - Decontamination without disruption to other rooms is required to care for live animals
 - Different species require different temperature and humidity control



Slide 42



Notes:

Zoning and Decontamination

- **Decontamination**
 - Some arrangements allow for maintenance access from outside the lab zone after decontamination
 - Requires more circulation space & more doors
 - Consider frequency of decontamination and risks involved with accessing through the lab zone



Slide 44



Notes:

Mechanical Systems

Individual Activity:
Spend **5 minutes** reflecting upon the mechanical systems serving a lab you are familiar with.

Questions?

- How do the systems help to mitigate biorisk?
- Are there biological safety risks inherent in using or maintaining the system?
- Are there biological security risks inherent in using or maintaining the system?

Slide 45





Notes:

Building Systems - Plumbing

Class Activity:

Questions - What is different about plumbing systems in a *laboratory vs. a typical building?*

What are the *unique requirements?*
Unique features?



Slide 46

Notes:

Plumbing Systems

- RO/DI Water

Centralized systems

Point of use systems

Carry in from central dispensing location

Service Space

Lab

Slide 42

Notes:



Plumbing Systems

- Laboratory Gases

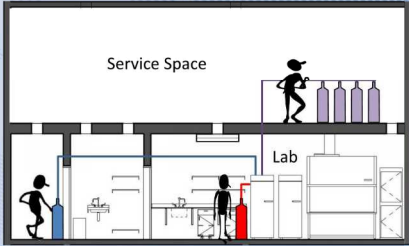
Centralized systems
Adjacent to need
Adjacent to lab



Slide 48



Notes:

Plumbing Systems

- Containment Issues

Assess risk and check guidelines then consider

- Backflow prevention
- Avoid recirculation
- No vacuum

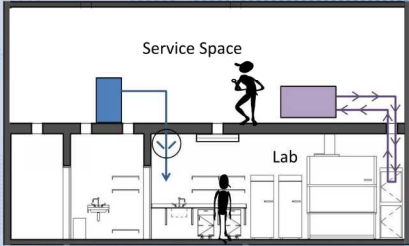

Slide 49

BEP

Notes:

Plumbing Systems

- Effluent Treatment
 - Neutralization systems
 - To balance pH level
 - To neutralize chemicals
 - To render effluent safe for release to sewer
 - Biological waste treatment (Effluent Decontamination Systems)
 - Chemical or heat treatment
 - To render effluent safe for release to sewer

The diagram shows a cross-section of a laboratory. At the top is a 'Service Space'. Below it is a 'Lab' containing various pieces of equipment. Below the Lab is another 'Service Space'. A red line represents the effluent path, starting from the Lab, going down, then right, then down again into a red cylindrical tank in the lower Service Space. A person is shown in the lower Service Space near the tank. The top Service Space also contains a person. Logos for BEP and OSEP are visible at the bottom right of the diagram.

Notes:

Plumbing Systems

- Effluent Decontamination Systems (EDS)
 - Heat Treatment two basic types

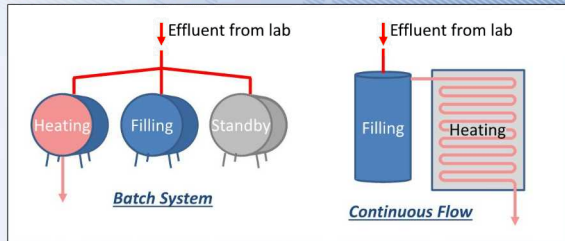

Notes:

Plumbing Systems

- Distribution

Consider

- Ability to *clean*
- Ability to *inspect*

Solution will depend on lab type, wall construction and guideline requirements

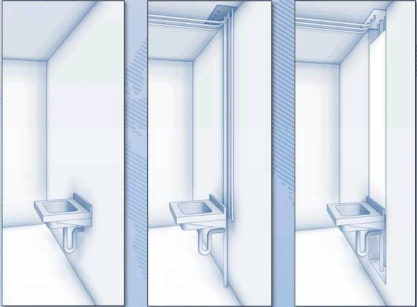

Distribution in wall Exposed piping Accessible chase



Slide 52



Notes:

Plumbing Systems

Individual Activity:
Spend **5 minutes** reflecting upon the plumbing systems serving a lab you are familiar with.

Questions?

- How do the systems help to mitigate biorisk?
- Are there biological safety risks inherent in using or maintaining the system?
- Are there biological security risks inherent in using or maintaining the system?

Slide 53

Notes:

Building Systems - Electrical

Class Activity:

Questions - What is different about electrical systems in a *laboratory vs. a typical building?*

What are the *unique requirements?*

Unique features?



Slide 54

Notes:

Electrical Systems

- Similar to plumbing systems there are biosafety issues regarding the ***distribution*** of electrical systems, exposed conduits can make lab wall surfaces difficult to clean.
- Additionally electrical ***penetrations through containment barriers*** must be well sealed.

Slide 55



Notes:

Electrical Systems

- Greatest risks to biosafety and biosecurity related to electrical systems however are from power failures.
- Therefore redundancy on electrical service is critical.

Slide 56



Notes:

Building Systems

- What could go wrong?
- Failures and redundancy strategies....

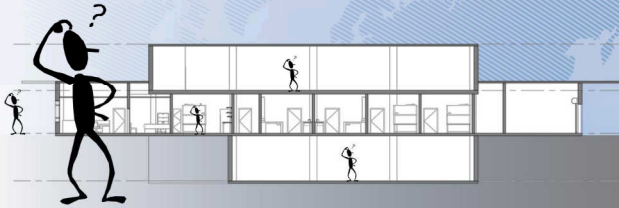

Slide 57



Notes:

Failures and redundancy strategies

Group Activity:

In your group spend **20 minutes** discussing potential failures in our example lab and prepare to present to the class:

One failure affecting **biosafety** and the mitigation strategy you would recommend.

One failure affecting **biosecurity** and the mitigation strategy you would recommend.





Slide 58



Notes:



N + 1 Redundancy

Common approach is **N+1** redundancy where N=number of elements required

100%	100%	100%	100%	standby
				
		67%	67%	67%

Program Requirement **N+1**

Air Handling Unit (AHU) example. If 2 are required provide 3 to cover failures or maintenance shut downs. One may sit as idle standby or all might run at reduced capacity.

Slide 59  

Notes:

Review of Laboratory Building Systems

Review

To wrap-up, let's discuss what we learned about Laboratory Building Systems



What did we learn? What does it mean? Where do we go from here?



Notes:

Key Messages

- Laboratories have unique requirements that influence virtually all building system designs.
- Planning to accommodate the appropriate space for building systems is an essential part of the design process.
- Mechanical systems play a critical role in any lab where containment of biological agents or toxins is a concern.
- Plumbing systems also often play a role in preventing the release of biological agents from a laboratory.
- The distribution and zoning of all building systems must consider biological safety issues.
- System redundancy must be considered wherever building systems are relied upon as part of the biological containment or biosecurity system.



- Laboratories have unique requirements that influence virtually all building system designs.
- Planning to accommodate the appropriate space for building systems is an essential part of the design process.
- Mechanical systems play a critical role in any lab where containment of biological agents or toxins is a concern.
- Plumbing systems also often play a role in preventing the release of biological agents from a laboratory.
- The distribution and zoning of all building systems must consider biological safety issues.
- System redundancy must be considered wherever building systems are relied upon as part of the biological containment or biosecurity system.

Remember your action plan!

Action Plan

By the end of this lesson, I would like to:

KNOW	FEEL	BE ABLE TO DO	
Your learning doesn't stop with this lesson. Use this space to think about what else you need to do or learn to put the information from this lesson into practice.			
What more do I need to know or do?	How will I acquire the knowledge or skills?	How will I know that I've succeeded?	How will I use this new learning in my job?

Use space on back, if needed  

Laboratory Building Systems

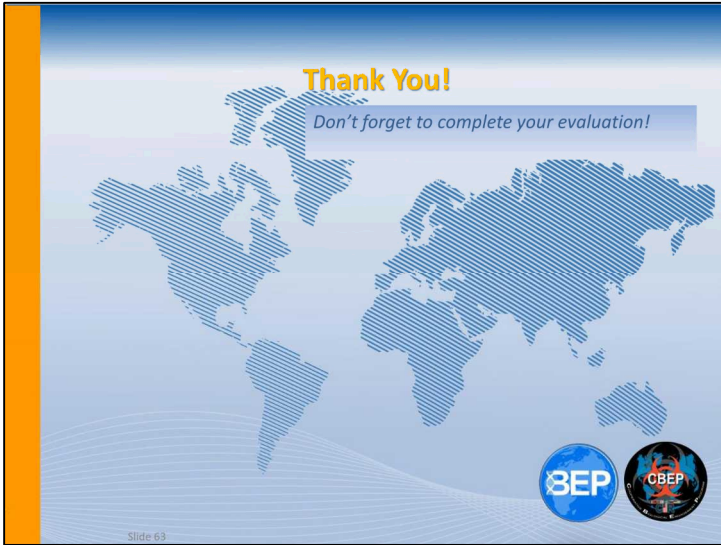



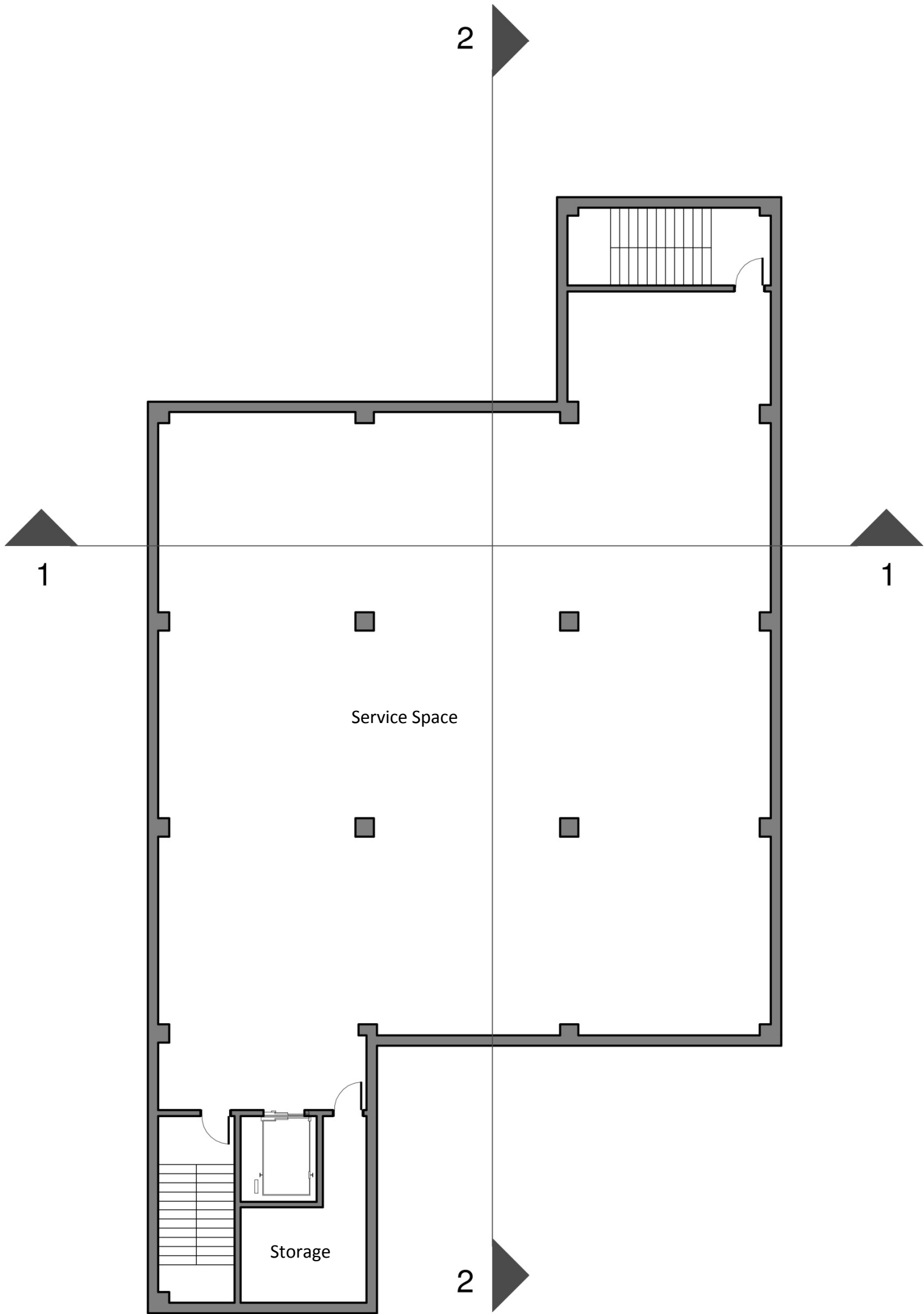

Building Systems Lab Level 0

1 : 150



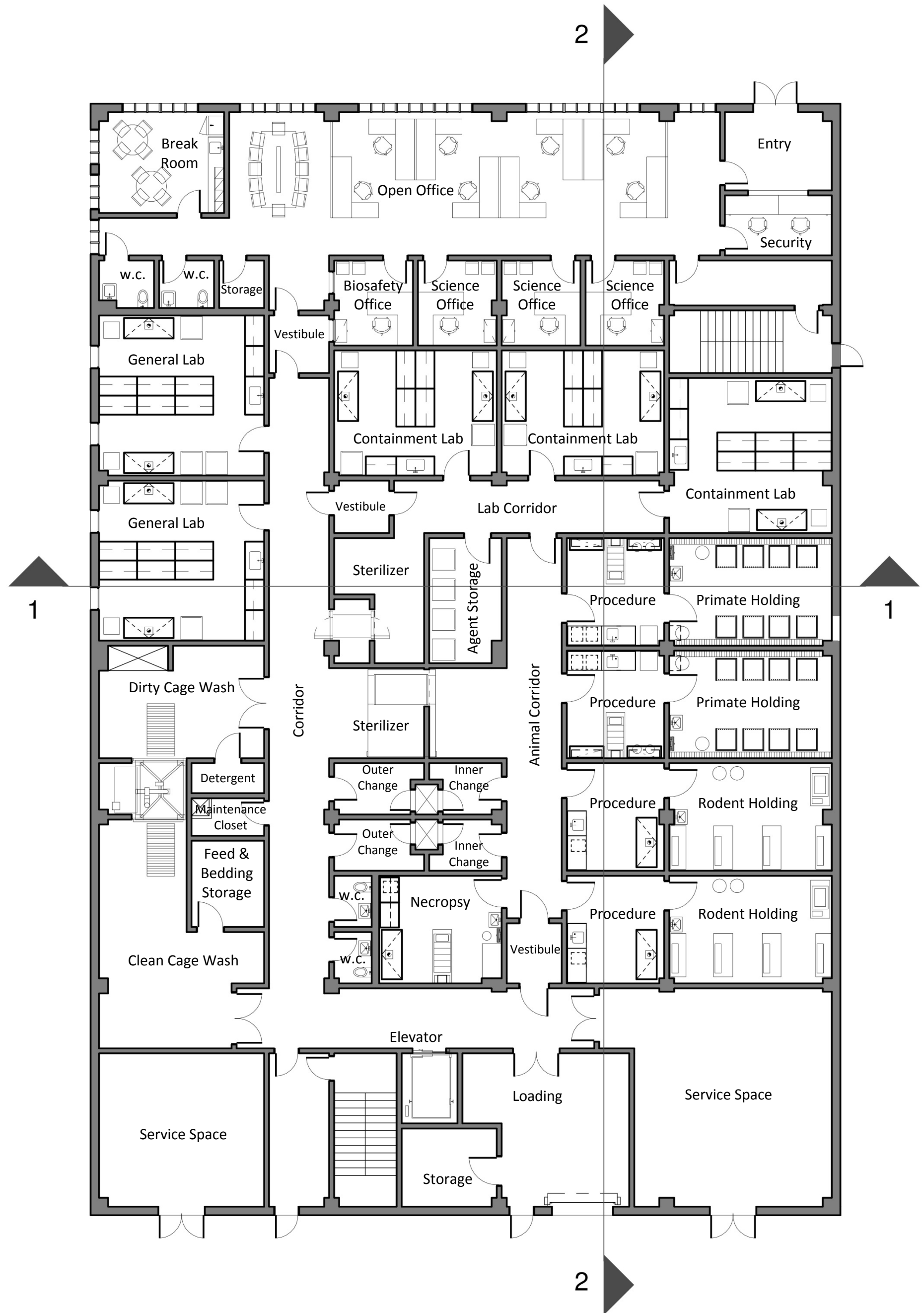

Building Systems Lab Level 1

1 : 150



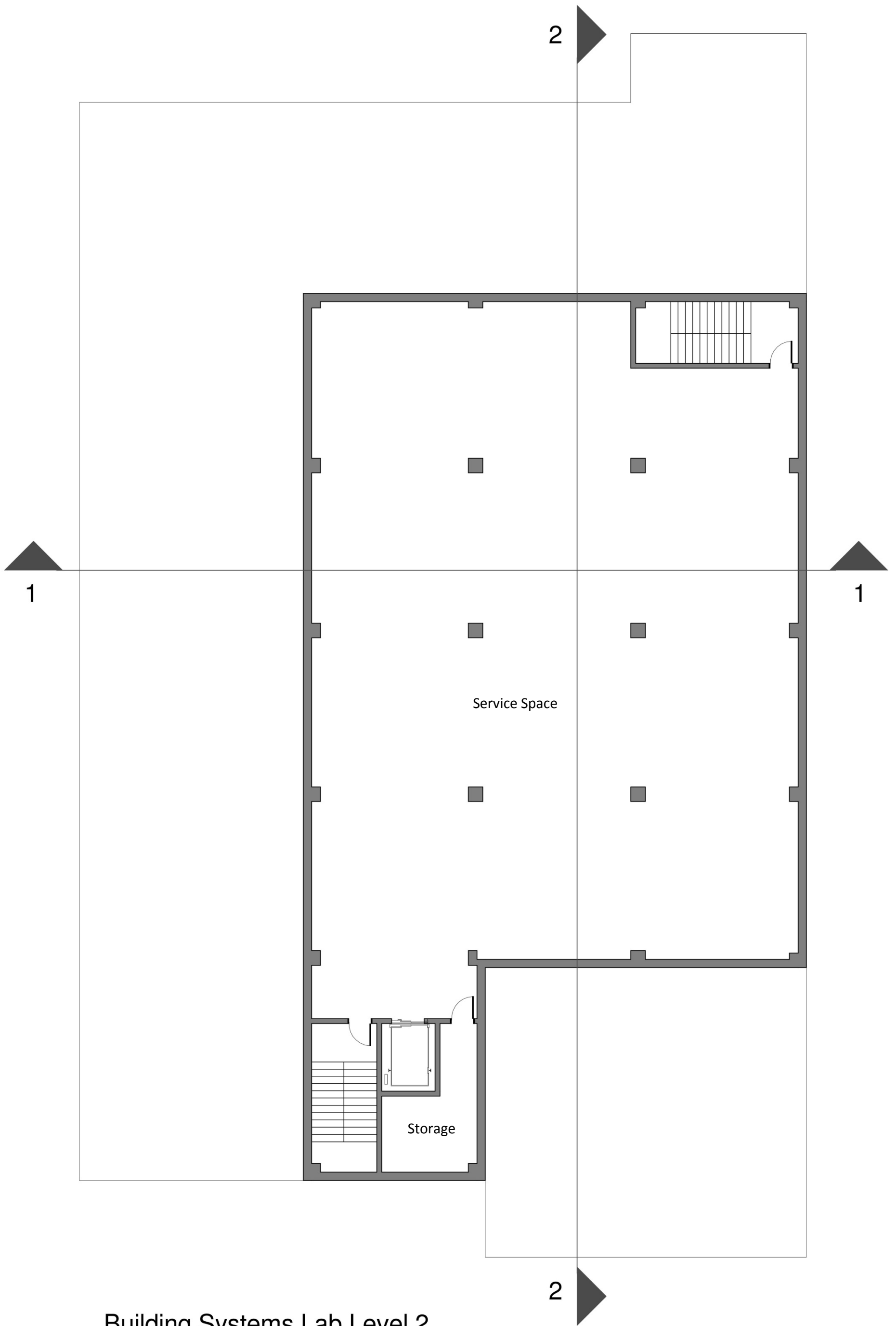

Building Systems Lab Level 2

1 : 150



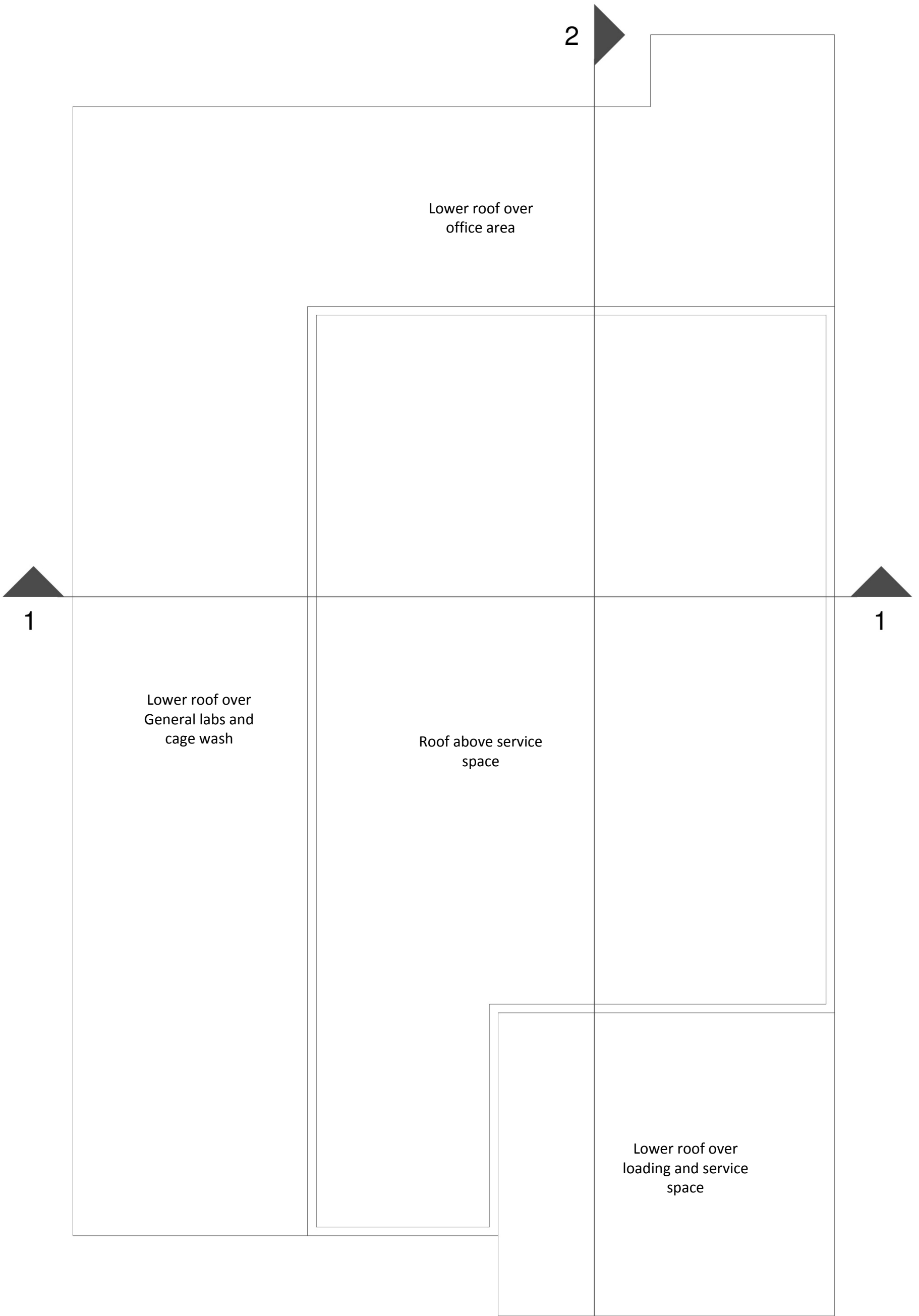

Building Systems Lab Roof Plan

1 : 150

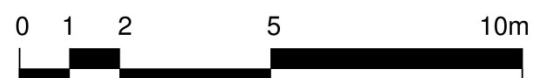

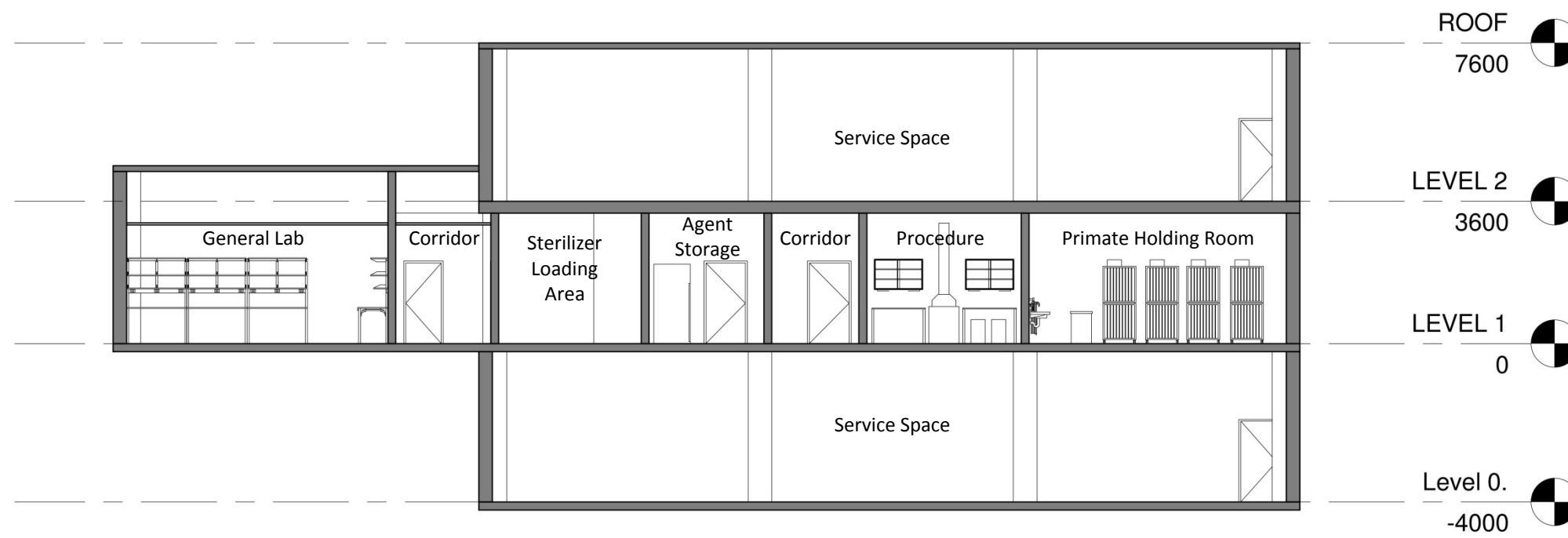

Section 1

1 : 150

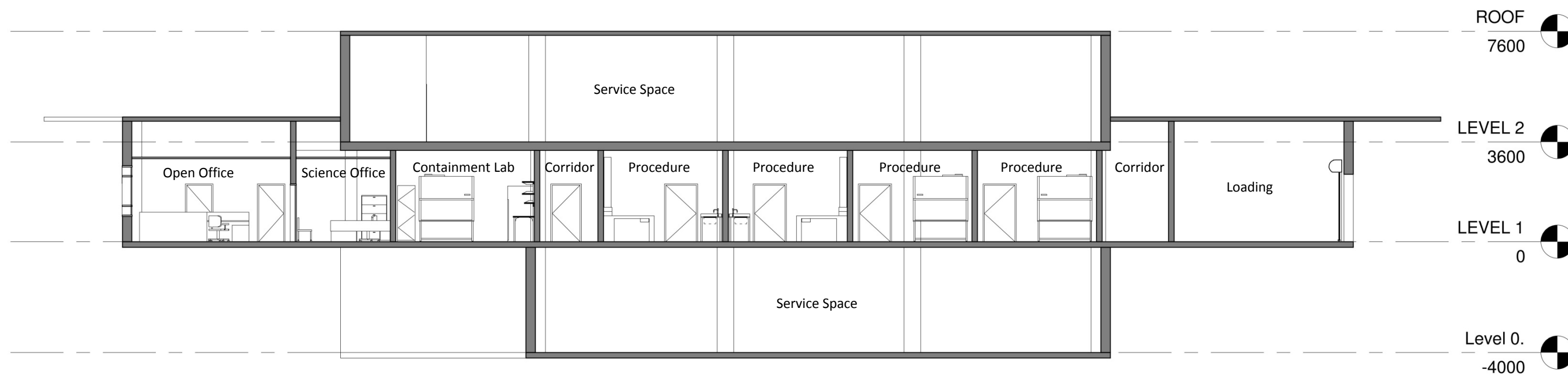

Section 2

1 : 150

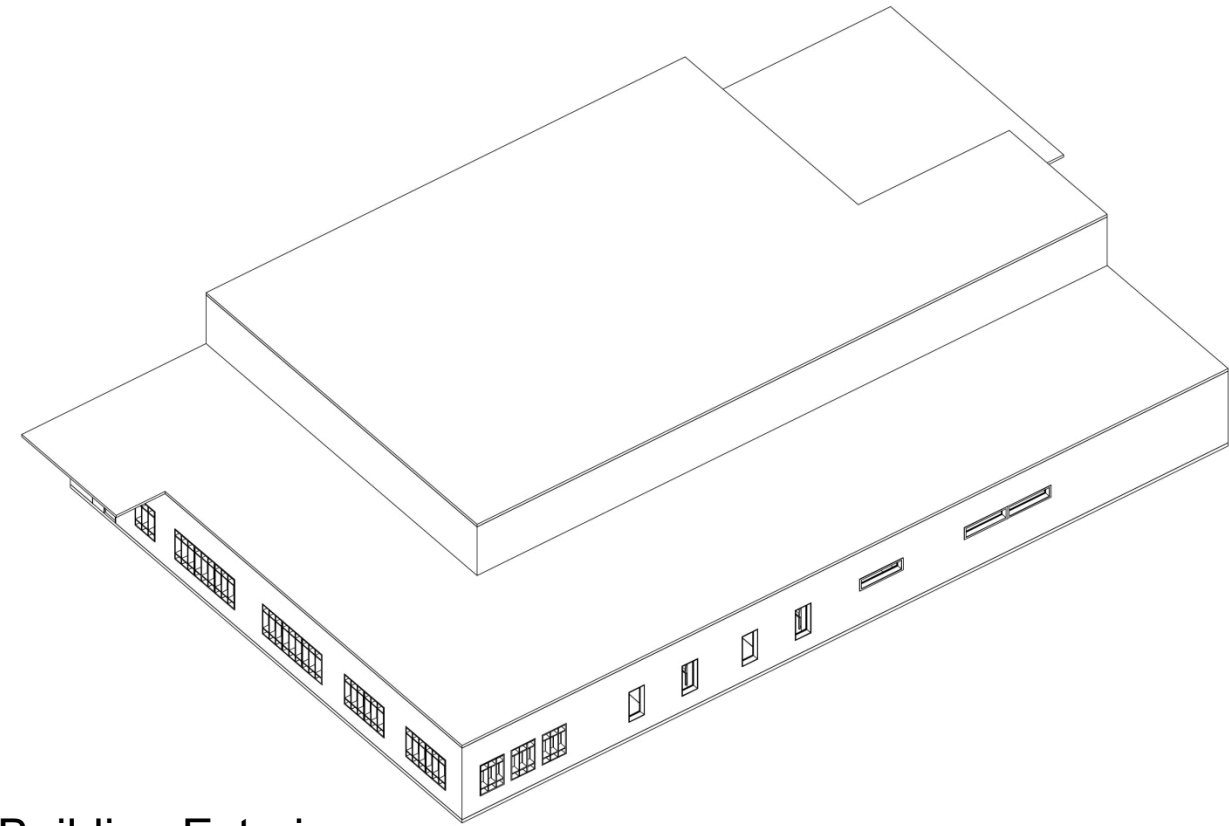

Building Exterior

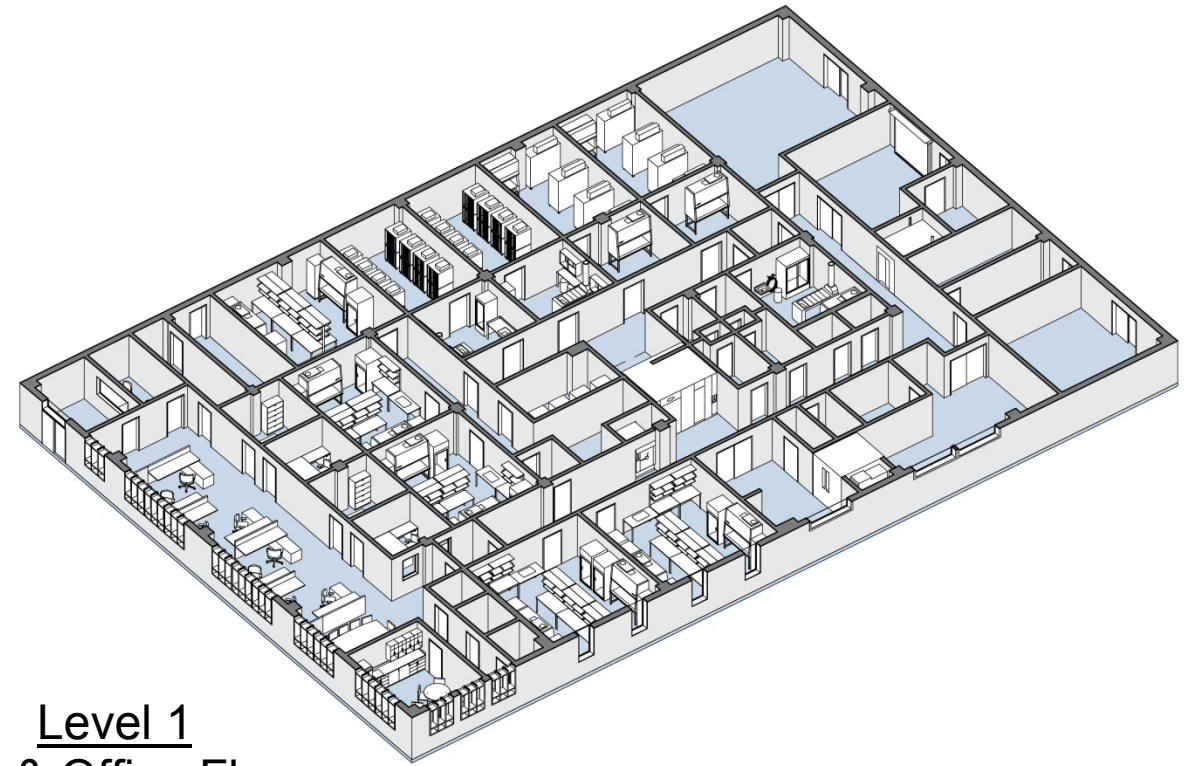

Level 1
Lab & Office Floor

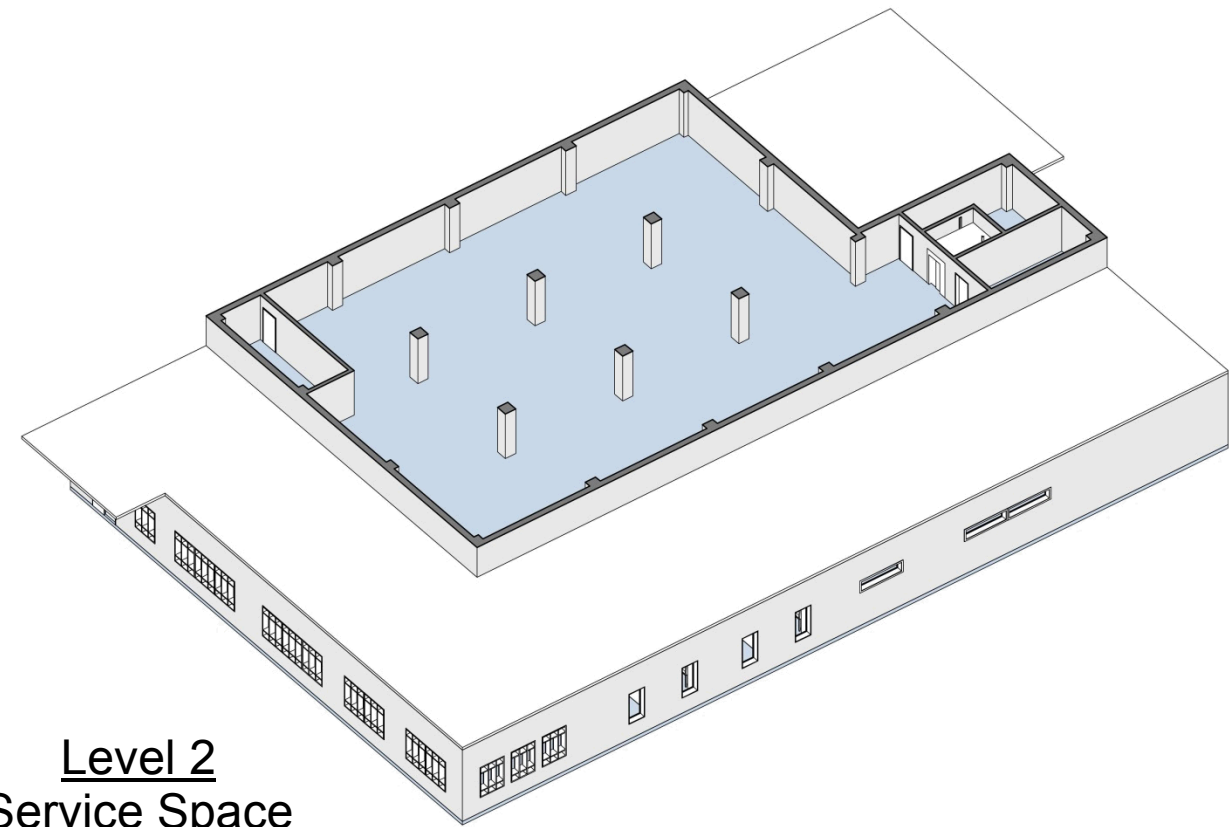

Level 2
Service Space

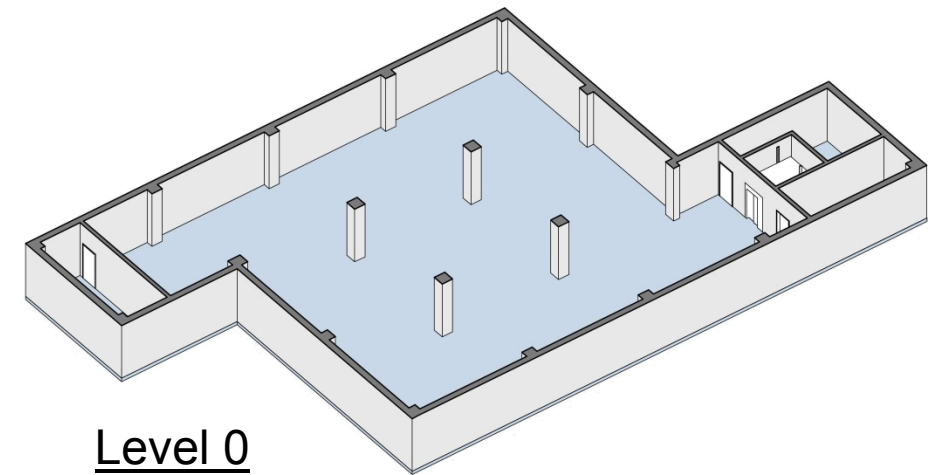

Level 0
Service Space

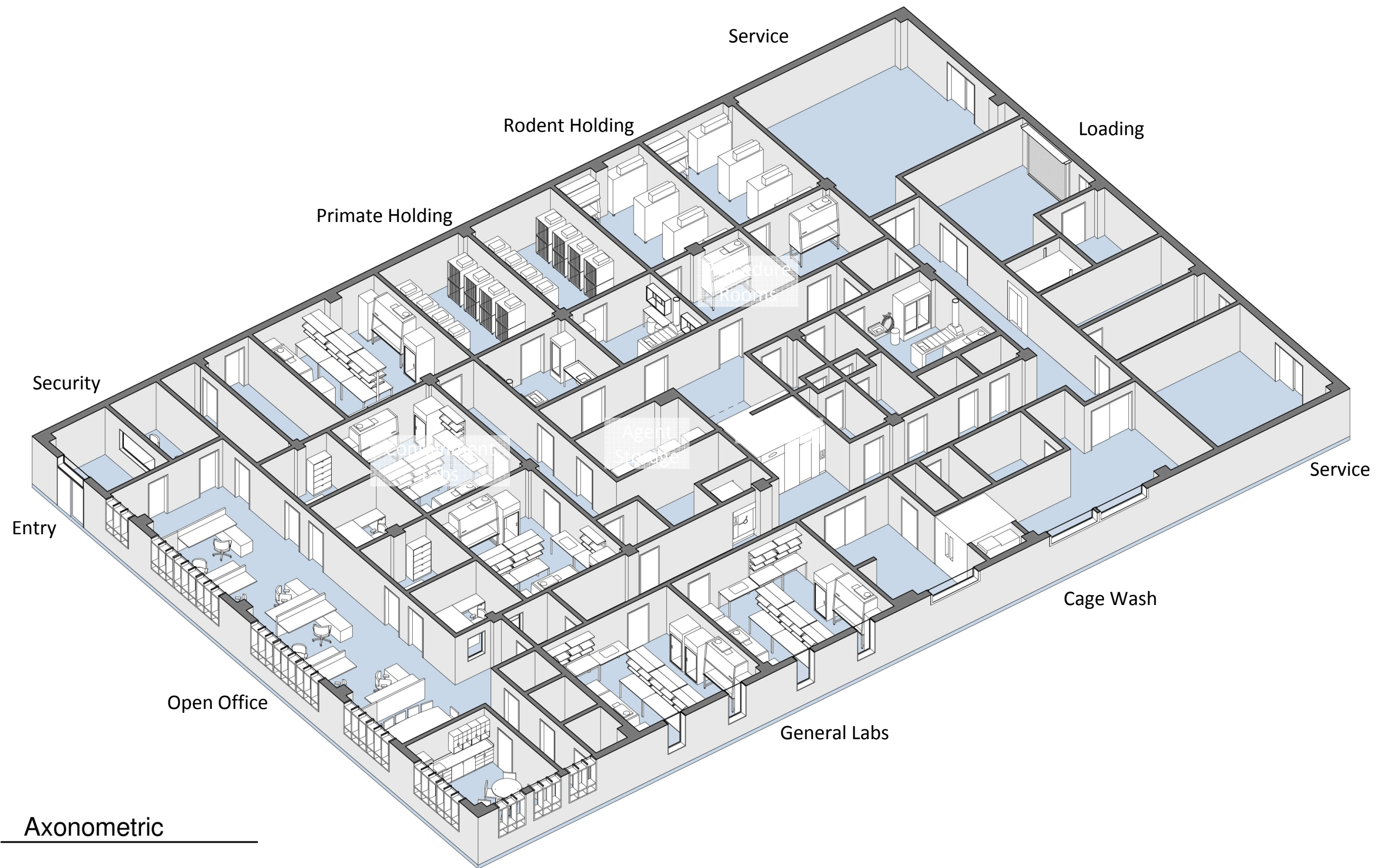

Axonometric



Open Office Area

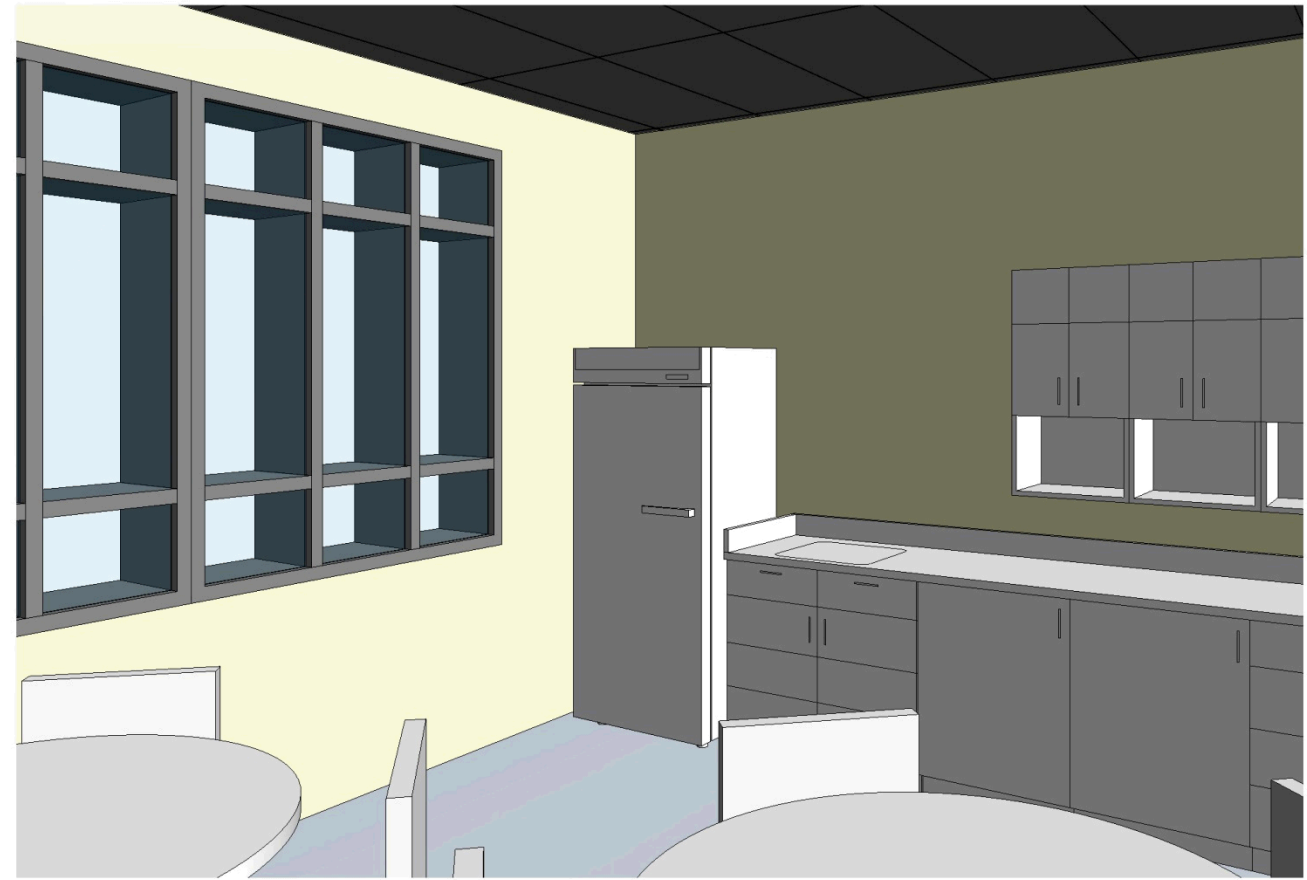

Break Room



General Laboratory

Interior Views

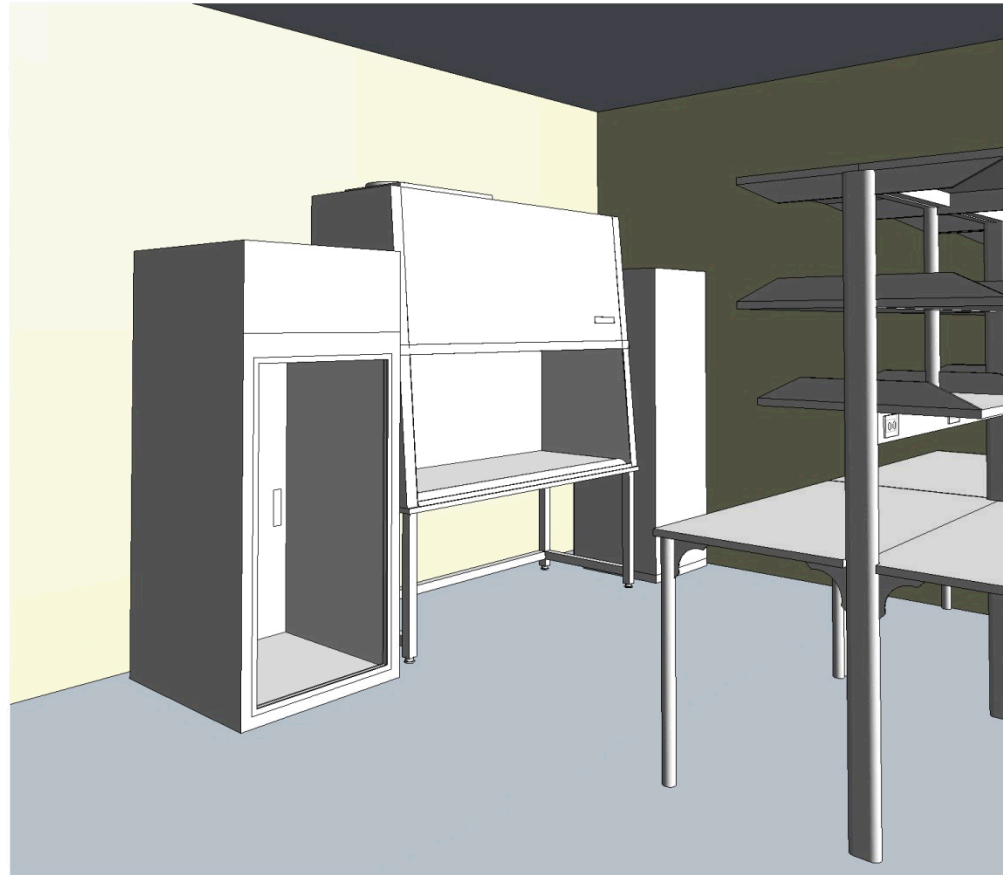

Containment Laboratory

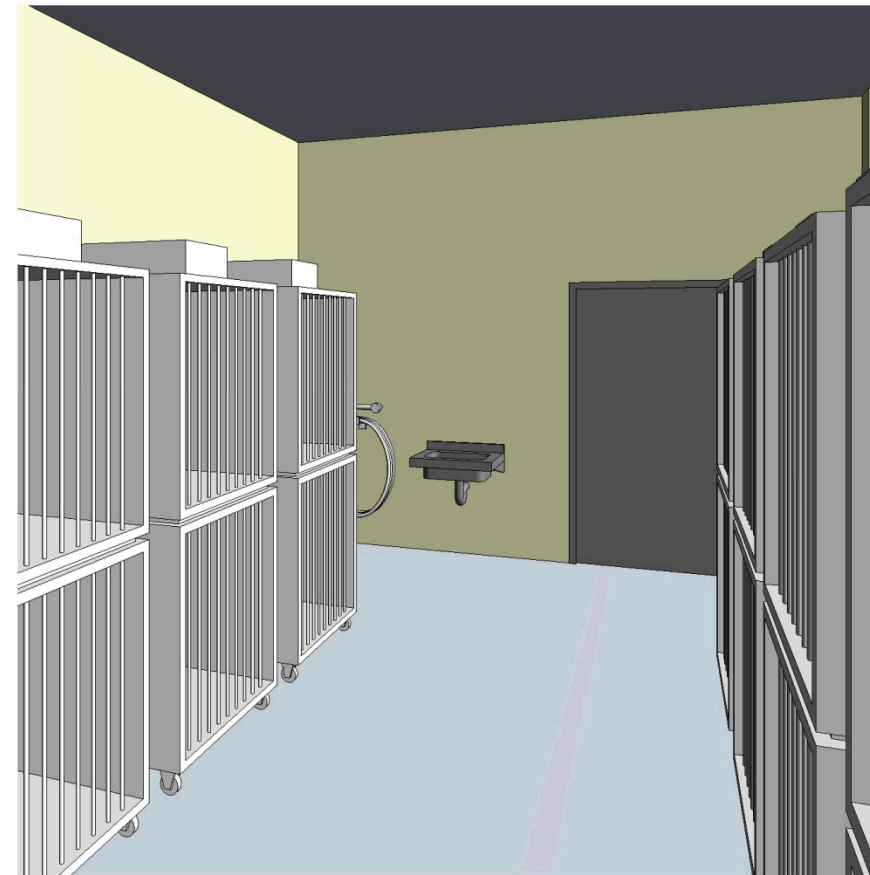

Primate Holding Room

Interior Views



Rodent Holding Room



Cage Wash Area

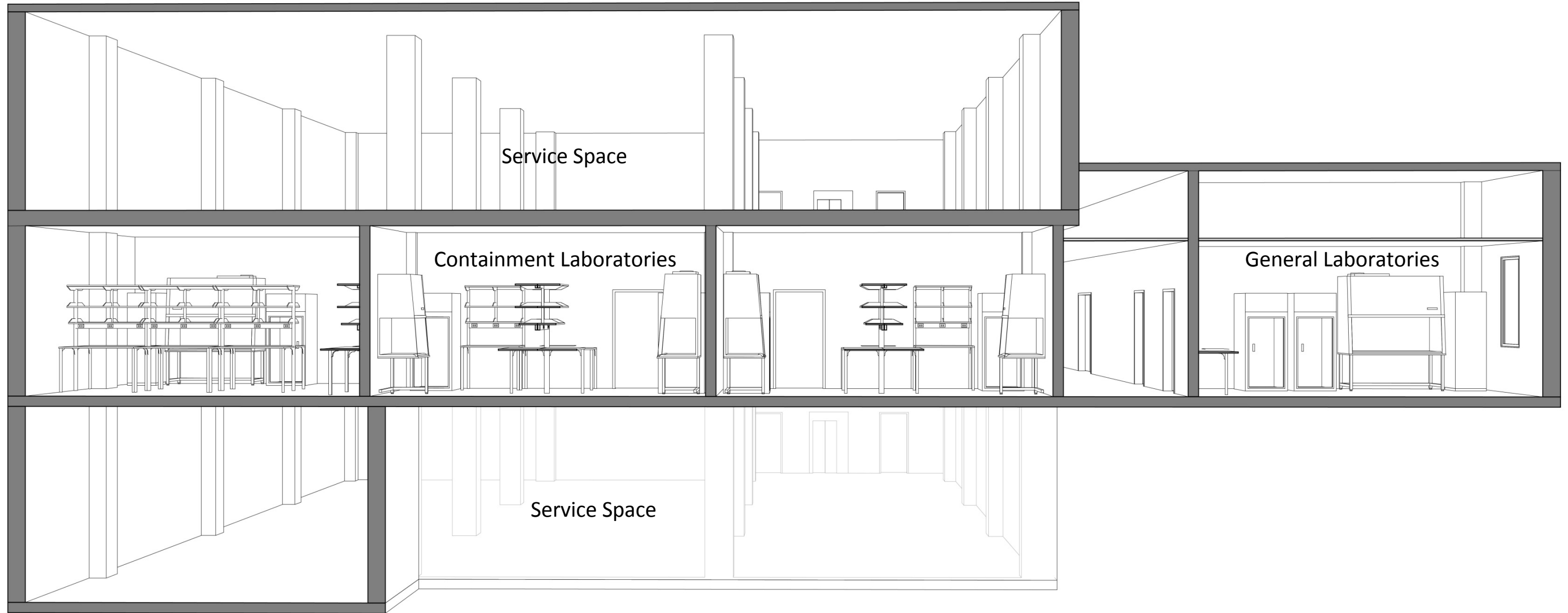

Section View