



New approaches for soft magnetic materials

Todd Monson, tmonson@sandia.gov

Approach

Magnetic materials comprise a significant portion of power electronics. To decrease the size requirements, new materials are required to work in conjunction with improved semiconductor switches. Specifically, magnetic materials capable of operating at higher switching frequency are needed.

Passive elements comprise the bulk of the volume and mass of a power converter

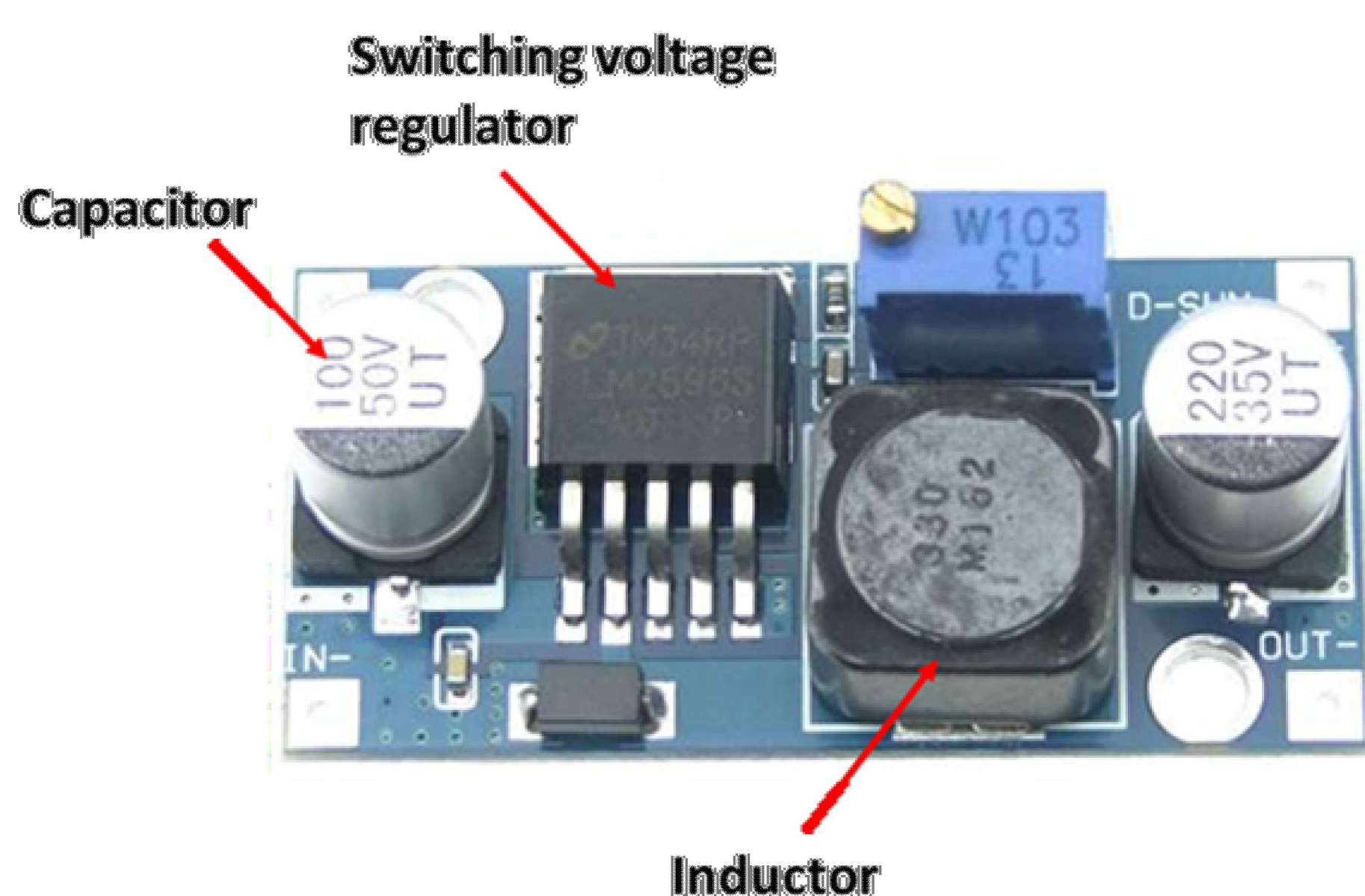

Soft magnetic material development

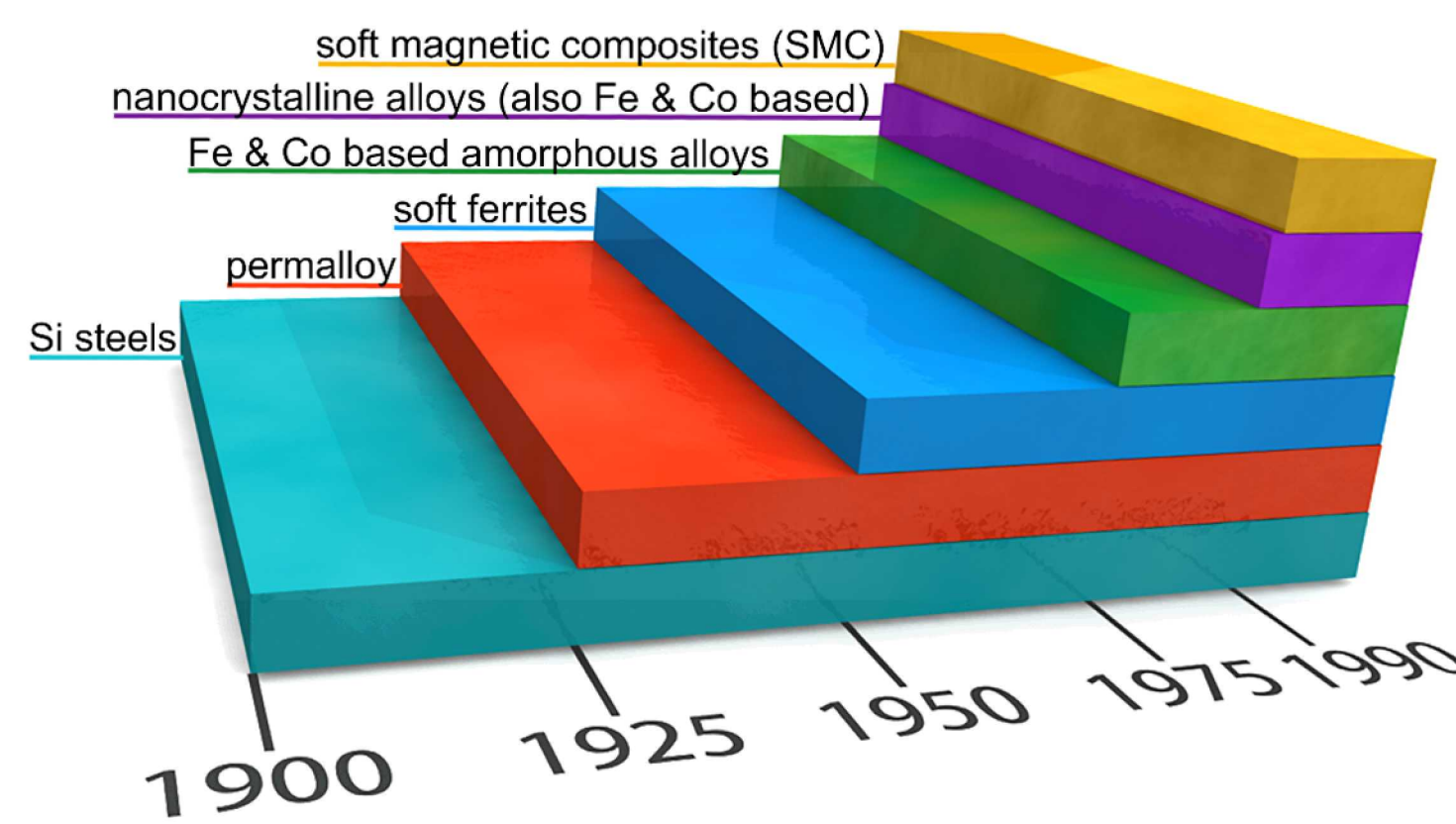

Adapted from: L.A. Dobrzański, M. Drak, B. Ziębowski, Materials with specific magnetic properties, *Journal of Achievements in Materials and Manufacturing Eng.* **2006**, 17, 37.

No new soft magnetic materials introduced to the market since the 1990s

In addition to taking several different approaches to new materials, our composite magnetics enable new device designs:

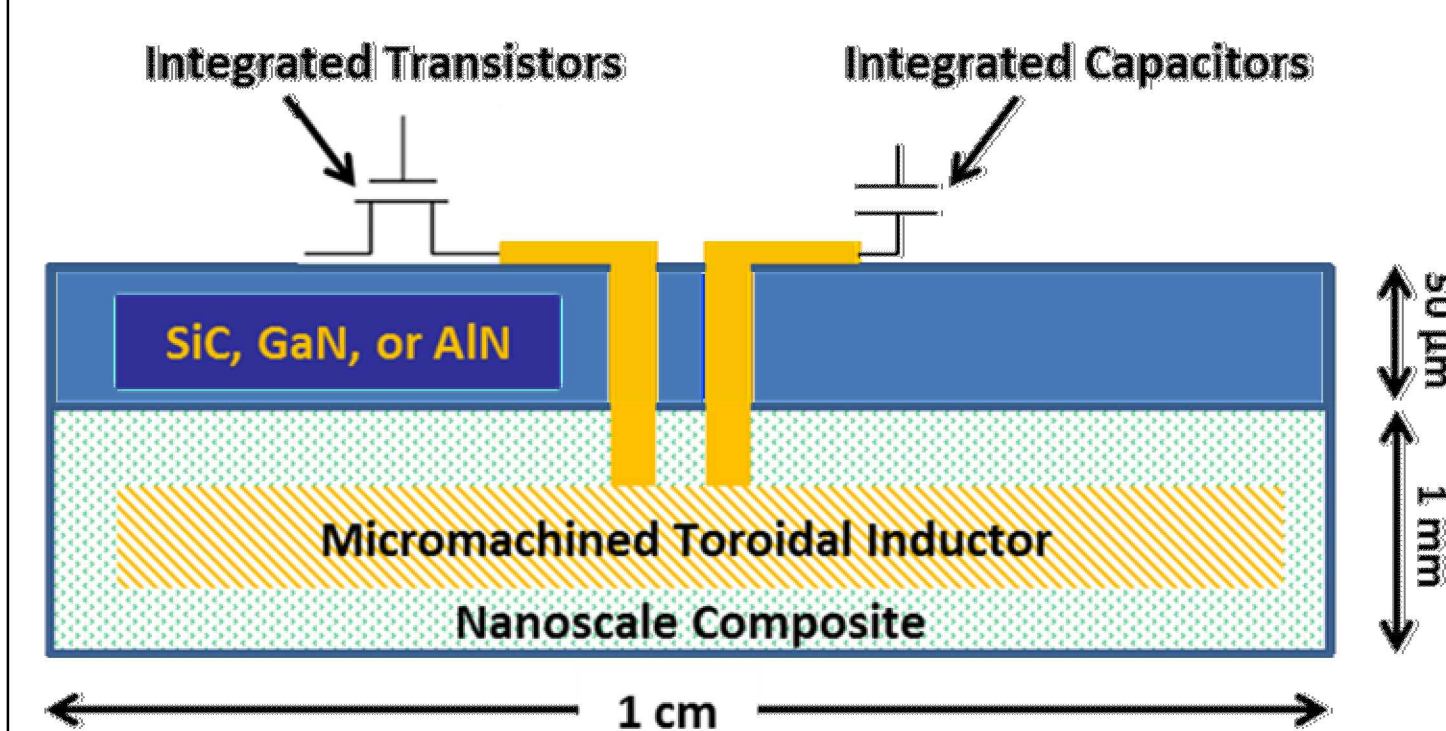

Future state of power electronics with embedded components

Results/Accomplishments

New soft magnetic materials:

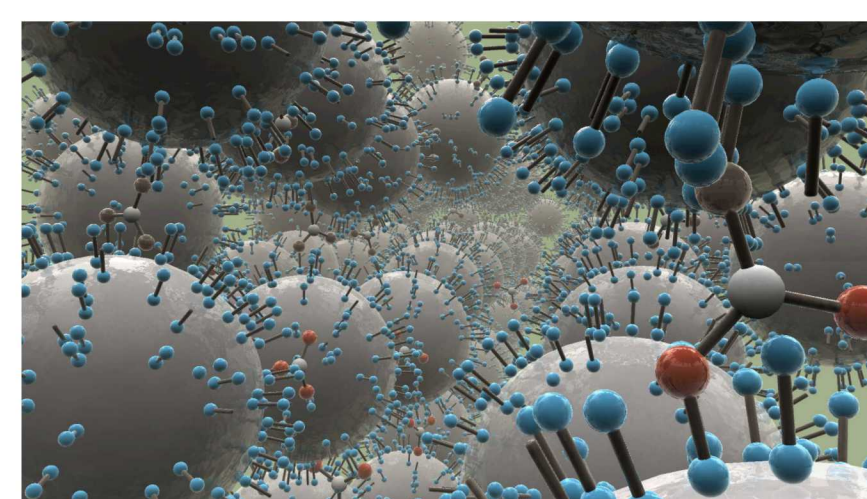
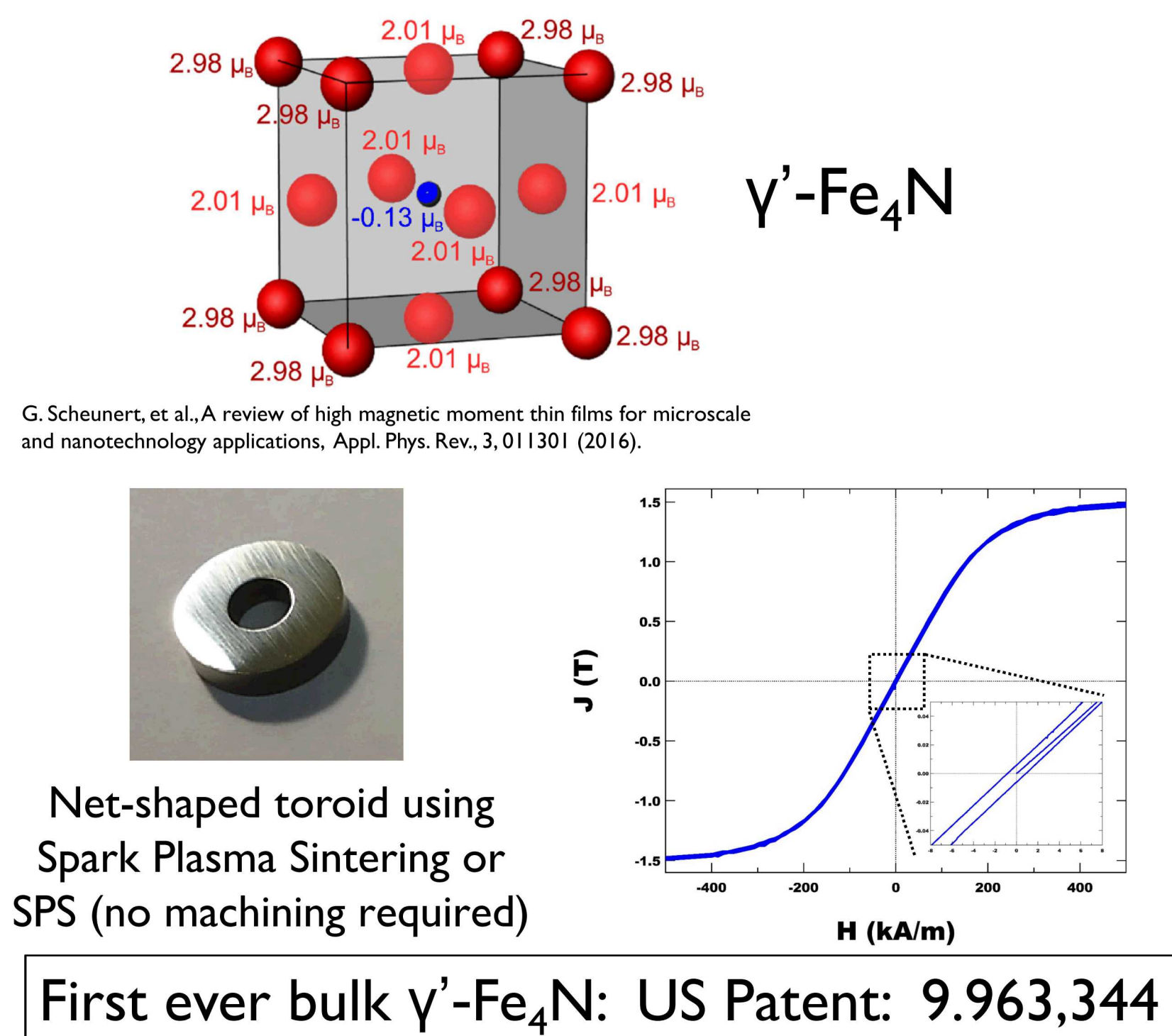

Magnetic nanocomposite (Fe or Fe₃O₄ inorganic phase)

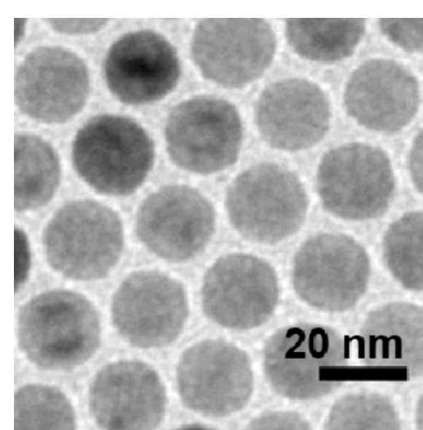

High quality Fe₃O₄ nanoparticles

Iron/epoxy 3D printed toroid

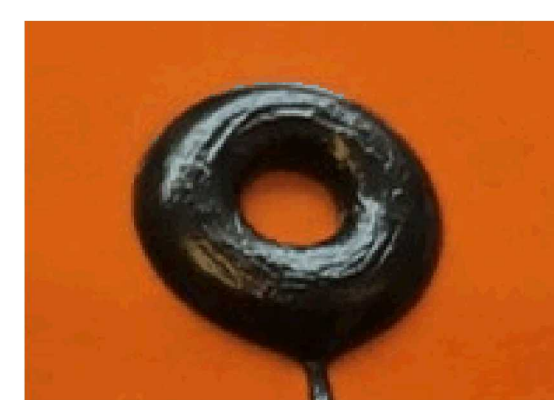

3-layer microinductor fabrication process:

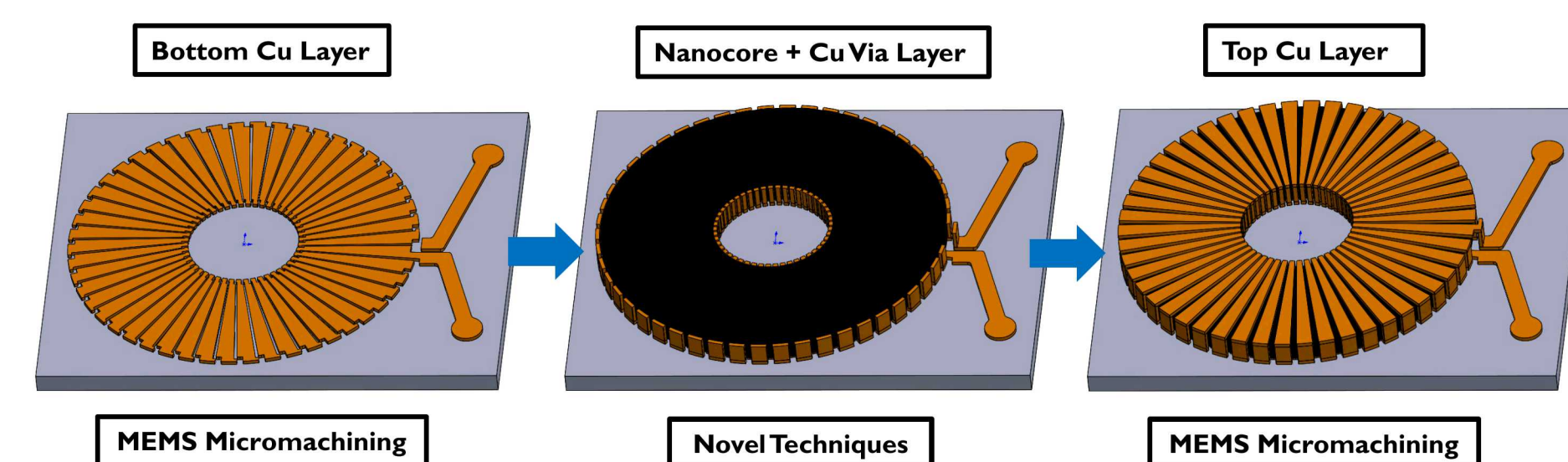

- MEMS Micromachining: optical photolithography, electroforming, e-beam metal evaporation
- Novel Techniques: 3D printing (molds, wires), femtosecond laser drilling (nanocomposite)

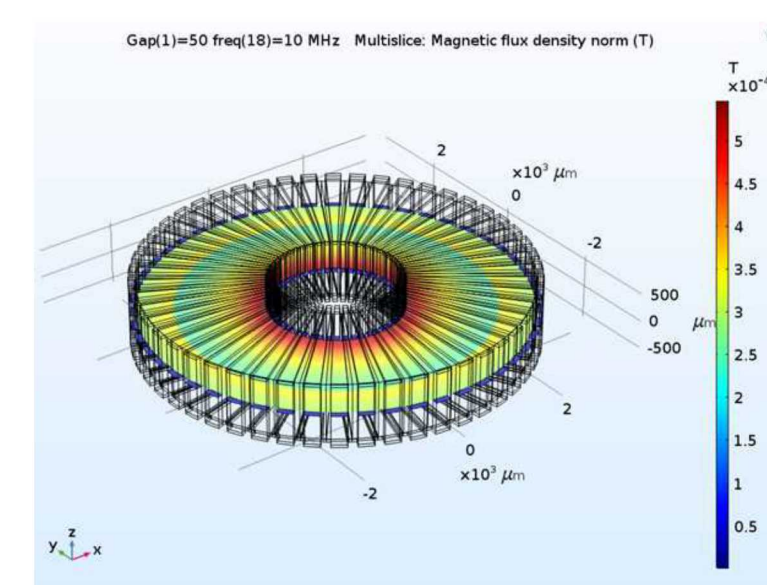

COMSOL model of microinductor with nanocomposite core

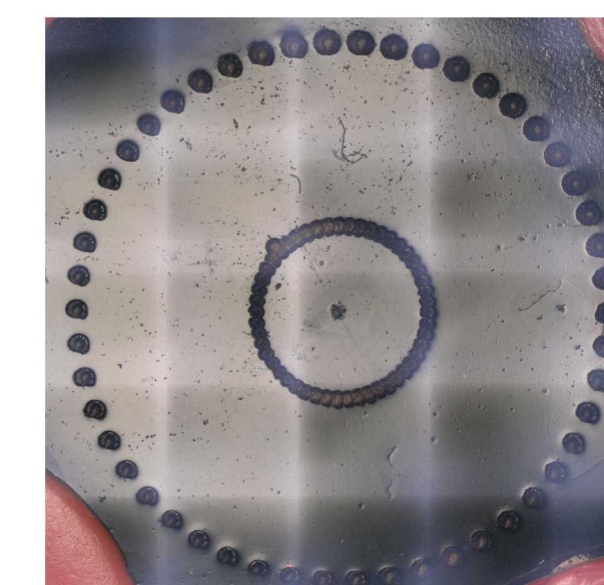

Laser Drilled Cu Vias

Summary & Impact

- LDRD investment: Enabling Modular Architectures with Radiation-Hard Bus-Based Power Delivery (Grand Challenge with ND impact), Magnetic Nanocomposites for High Performance Inductor Materials (Materials IA)
- Mission related (ND) projects and collaborations are growing: power electronics, NG, stronglinks
- Energy related projects are also growing: DOE/Office of Electricity, DOE/Vehicle Technologies Office, ARPA-E
- Our portfolio of magnetic materials projects is expanding beyond solely soft magnets for inductors: our work now includes transformers, electrical machines, sensing, and even some permanent magnets
- Uniqueness: multidisciplinary team (physics, chemistry, materials science, EE), strength in microfabrication (μ Fab, electrodeposition, novel micromachining), extensive test beds and insertion opportunities

Collaborators: Dale Huber (SNL), Eric Langlois (SNL), Jamin Pillars (SNL), Bob Kaplar (SNL), Jason Neely (SNL), Jack Flicker (SNL), John Watt (LANL), Enrique Lavernia (UC Irvine), Scott Sudhoff (Purdue), and many others...

Publications and Invited Presentations:

- T. C. Monson, B. Zheng, R. E. Delany, C. J. Pearce, E. D. Langlois, S. M. Lepkowski, T. E. Stevens, Y. Zhou, S. Atcitty, E. J. Lavernia, "Soft magnetic multi-layered FeSiCrB-Fe₄N metallic glass composites fabricated via spark plasma sintering," *IEEE Magnetics Letters*, DOI: 10.1109/LMAG.2019.2906832.
- J. M. Silveira, E. Ferrara, D. L. Huber, T. C. Monson, "Soft magnetic materials for a sustainable and electrified world," *Science* **362**, 418 (2018). [Invited Review]
- J. Watt, G. C. Bleier, Z. W. Romero, B. G. Hance, J. A. Bierner, T. C. Monson, D. L. Huber, "Gram scale synthesis of Fe/Fe₃O₄ core-shell nanoparticles and their incorporation into matrix-free superparamagnetic nanocomposites," *Journal of Materials Research* **33**, 2156-2167 (2018).
- Z. Fu, B. E. MacDonald, T. C. Monson, B. Zheng, W. Chen, E. J. Lavernia "Influence of heat treatment on microstructure, mechanical behavior, and soft magnetic properties in an fcc-based Fe₂₉Co₂₈Ni₂₉Cu₇Ti₇ high-entropy alloy," *Journal of Materials Research* **33**, 2214-2222 (2018).
- E. D. Langlois, T. C. Monson, D. L. Huber, J. Watt, "Finite element modeling of nanoscale-enabled microinductors for power electronics," *Journal of Materials Research* **33**, 2223-2233 (2018).

Invited Presentations:

- T. C. Monson, T. E. Stevens, D. A. Vargas, R. M. Van Ginhoven, B. Zheng, Y. Zhou, M. Fraga, E. Lavernia, "Synthesis of Nanostructured Ferriic Materials for Energy Conversion," *Materials Science & Technology 2018* (Columbus, OH, 2018)
- T. C. Monson, T. E. Stevens, D. A. Vargas, R. M. Van Ginhoven, "Experimental and Theoretical Characterization of Functionalized Barium Titanate Nanoparticles," *International Power Modulator and High Voltage Conference* (Jackson Lake Lodge, WY, 2018)

