

# Electrical Power System Support-Function Capabilities of Residential and Small Commercial Inverters

Sigifredo Gonzalez, Jay Johnson, Jason Neely

Sandia National Laboratories, Albuquerque, New Mexico, 87185, USA

**Abstract** — Presently, approximately 20 GW or 2% of the nation’s generating capacity comes from solar, and solar penetration is increasing. However, for this trend to continue without adversely affecting electrical power system (EPS) performance, the photovoltaic inverters must participate in voltage- and frequency-regulation requirements. EPS support capabilities under development are the low-/high-voltage and low-/high-frequency ride through, volt-VAR, frequency-watt, watt-power factor, commanded power factor, commanded power functions, and others. Each of the functions have parameter set points, and most have ramp rates for implementation of the functions as defined in the International Electrotechnical Commission Technical Report 61850-90-7. This paper focuses on methods to quantify EPS support functions for DER certification. Sandia National Laboratories and Underwriters Laboratories, in collaboration with industry stakeholders, have developed a draft test protocol that efficiently and effectively evaluates support-function capabilities. This paper describes the functions, their intended use, and results of EPS support functions in a controlled laboratory environment.

**Index Terms** — electrical power system, voltage and frequency regulation, test protocol, EPS support functions.

## I. INTRODUCTION

The nation’s solar generating capacity continues to grow, and a DOE vision study suggests 14% of the total electricity demand could be met by solar by 2030 [1]. This displaces traditional electricity generation coming from centralized, dispatchable generators with an increasing amount of electricity production from distributed, variable generation resources. To minimize the adverse impacts from this shift, power converters have implemented functions that also provide electrical power system (EPS) support capabilities.

These capabilities are now permissible through evolutionary changes to the utility interconnection standard IEEE 1547 [2]. The major revision takes time to implement; therefore in the interim, IEEE 1547a-2014 has been approved to allow distributed energy resources (DERs) to participate in voltage and frequency regulation in coordination with the area EPS. Presently, revisions to certain interconnection standards are being drafted by working groups comprised of various stakeholders, including inverter manufacturers, utilities, system integrators, nationally recognized testing laboratories, and government laboratories.

While IEEE 1547a allows voltage and frequency support, there are no details on how this capability is provided, and local jurisdictions have begun regulating this process. A

notable example is the approval of EPS support functions in the California Public Utilities Commission (CPUC) Electric Tariff Rule 21 [3]. The EPS support-function capabilities are being adopted in a staged approach by the CPUC. Thus far, only the first phase has been adopted by the commission, but it includes technical requirements for the following “smart inverter” capabilities:

- Anti-islanding protection
- Low-/high-voltage ride through (L/HVRT)
- Low-/high-frequency ride through (L/HFRT)
- Ramp rate specification, which limits changes in the power output
- Soft-start ramp rate on reconnection
- Dynamic Volt-VAR
- Fixed power factor (PF)
- Power reduction at high grid frequency (freq-watt)

Specific execution behaviors, parameter ranges, and default operating conditions for the above functions are defined in the revised CPUC Rule 21 and manufacturers are creating prototypes with these capabilities.

With the new interconnection requirements, it is necessary to establish new certification protocols to list products. To address this gap, Underwriters Laboratories (UL) has several working groups meeting on a weekly basis to develop a revised UL 1741 [4] certification test protocol, known as Supplement A or UL 1741 SA. This paper investigates a number of the test functions being proposed by the UL 1741 SA working groups.

## II. EPS SUPPORT FUNCTIONS

Changes in interconnection standards in California now allow photovoltaic (PV) inverters to provide active and reactive power to assist the EPS. Because renewable energy (RE) is variable and can change quickly, support functions were developed for power-electronic devices to minimize adverse effects under variable weather conditions and during other grid disturbances. Concise explanations of the functions follow.

### A. Low-/High-Voltage Ride Through

The L/HVRT function is a departure from the previous IEEE 1547-2003 required response to voltage anomalies. For a voltage sag/surge ride through, new standards require the

TABLE I. LOW-/HIGH-VOLTAGE RIDE-THROUGH SETTINGS FROM ELECTRIC RULE 21

Region	Voltage at PCC (% Nominal Voltage)	Ride-Through Until (s)	Ride-Through Operating Mode	Maximum Trip Time (s)
High Voltage 2 (HV2)	$V \geq 120$	No Ride Through	Not Applicable	0.16
High Voltage 1 (HV1)	$110 < V < 120$	12	Momentary Cessation after 0.16 Sec	13
Near Nominal (NN)	$88 \leq V \leq 110$	Indefinite	Continuous Operation	Not Applicable
Low Voltage 1 (LV1)	$70 \leq V < 88$	20	Mandatory Operation	21
Low Voltage 2 (LV2)	$50 \leq V < 70$	10	Mandatory Operation	11
Low Voltage 3 (LV3)	$V < 50$	1	Momentary Cessation after 0.16 Sec	1.5

TABLE II. LOW-/HIGH-FREQUENCY RIDE-THROUGH SETTINGS FROM ELECTRIC RULE 21

Region	System Frequency Default Settings	Minimum Range of Adjustability (Hz)	Ride-Through Until (s)	Ride-Through Operational Mode	Maximum Trip Time (s)
High Frequency 2 (HF2)	$f > 62$	62.0–64.0	No Ride Through	Not Applicable	0.16
High Frequency 1 (HF1)	$60.5 < f \leq 62$	60.1–62.0	299	Momentary Cessation	300
Near Nominal (NN)	$58.5 < V \leq 60.5$	Not Applicable	Indefinite	Continuous Operation	Not Applicable
Low Frequency 1 (LF1)	$57.0 \leq f < 58.5$	57.0–59.9	299	Mandatory Operation	300
Low Frequency 2 (LF2)	$f \leq 57.0$	53.0–57.0	No Ride Through	Not Applicable	0.16

inverter to stay connected for a specific duration and then trip after the ‘must trip’ time for specific voltage regions shown in Table I.

*B. Low-/High-Frequency Ride Through*

The frequency ride-through function requires DER to continue operation during frequency anomalies. Since frequency deviations are typically regional events, the probability of these events affecting a large number of DERs is high. The frequency ride-through requirements are shown in Table II.

*C. Dynamic Volt-VAr Operation/Fixed Power Factor*

The Volt-VAr function provides dynamic voltage-regulation response based on local or area EPS voltage. Either real or reactive power-prioritization behavior determines if real power is reduced when the inverter reaches its kVA limits. The volt-VAr characteristic four-point curve showing the voltage and reactive parameter settings is shown in Figure 1.

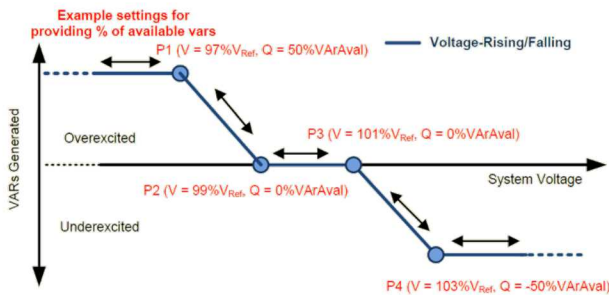

Fig. 1. Typical volt-VAr curve.

The fixed PF function sets the displacement angle as a response from a supervisory controller, local conditions, schedule, or other factors. It operates independently of voltage and frequency conditions at the point of common

coupling (PCC) and may include a ramp rate and delay time. Electric Rule 21 requires an operating range of  $\pm 0.9$  PF for  $< 15$  kW systems and  $\pm 0.85$  PF for  $> 15$  kW systems.

*D. Ramp Rates/Soft-Start Ramp Rate*

The ramp-rate function is an upper limit for the rate of power change. The rate’s function is constrained by what the DER device can physically do; so dynamic irradiance conditions may cause the ‘down’ ramp rate to exceed the setting.

The soft-start ramp rate establishes the maximum ramp rate for connection or reconnection after any utility event has caused the inverter to disconnect. The adjustable rate can be between 1%–100%/second of the maximum current as mutually agreed upon by the area EPS operator and the DER operator.

III. EPS SUPPORT FUNCTION PERFORMANCE EVALUATION

Sandia National Laboratories has been working with inverter manufacturers to quantify the performance of area EPS support functions in a controlled laboratory setting [5-9]. For these evaluations, the functions were programmed through a manufacturer-provided graphical user interface which communicated to the equipment under test (EUT) over TCP/IP, and all of the assessments are implemented with the default ramp rates.

These evaluations are conducted with a programmable PV simulator providing the dc requirements and a programmable grid simulator providing the ac requirements. The PV simulator is capable of delivering a programmed IV curve characteristic at a given fill factor that is well within the inverter’s dc operating ranges, and execute fixed or dynamic irradiance and module temperature profiles. The following EPS support-function evaluations were conducted on single and multiple inverter configurations as shown in Figure 2. For

these evaluations, the ac simulator provided the external stimulus to capture the inverter response to voltage and

frequency anomalies and validate the response to draft

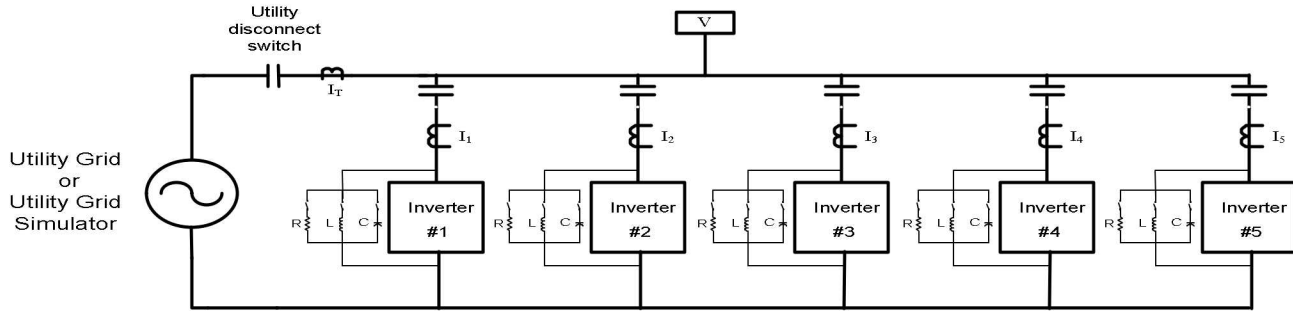

Fig. 2. Single or multi-inverter test configuration.

interconnection standard requirements. For each function evaluation, the function parameters were adjusted to meet the draft requirements and these parameter settings were used for the multi-inverter evaluation. The multi-inverter evaluations utilized inverters from the same manufacturer and each inverter had the function parameters identically set to determine the variation in response characteristics between the inverters.

#### A. Low-Voltage Ride-Through Response

The ac simulator is a regenerative device that reintroduces all power produced by the equipment under test (EUT) back to the utility and provides the EUT with a high power-quality signal for the EUT to synchronize to and produce power. The voltage and frequency variations can be a step function or a ramp function that varies from nominal voltage/frequency to a programmed voltage/frequency level.

The low-voltage ride-through laboratory assessment is shown in Figures 3–4. The ac simulator was programmed to provide a step change in voltage below 50% of nominal. At this voltage level the EUT is required to temporarily cease to energize the simulated grid within 0.16 seconds until 1 second after the event, as shown in low-voltage region 3 (LV3) in Table I. For this test, when voltage returns above 50% of nominal and the inverter ramps up the power and reaches pre-disturbance levels, see Figure 3. To capture a condition of five residential PV systems feeding a distribution transformer, the test was conducted with five inverters connected, as shown in Figure 2. The loads shown in the one-line diagram were disconnected for these evaluations and only used for the unintentional islanding evaluations discussed later. As with the single inverter test, the ac voltage is programmed for a voltage sag into LV3 region, and as shown in Figure 4. All five inverters have a momentary cessation of power, re-establish power output, and ramp up similar to the single-inverter case. As seen in the single-inverter case, when the voltage returns above 50% of nominal and the inverters ramp up the power, all reach pre-disturbance levels with nearly identical profiles. For simplicity, only LV3 low-voltage ride-through evaluation results are presented here, but similar results were seen for the other ride-through regions. In all

cases, there EUTs were compliant with the new Rule 21 requirements.

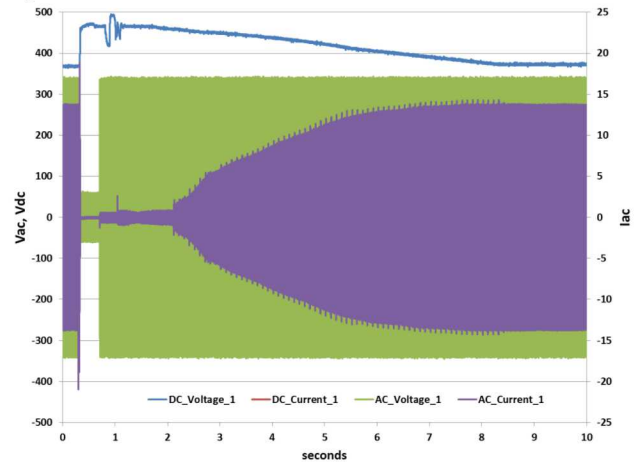

Fig. 3. Voltage < 50% of nominal ride through.

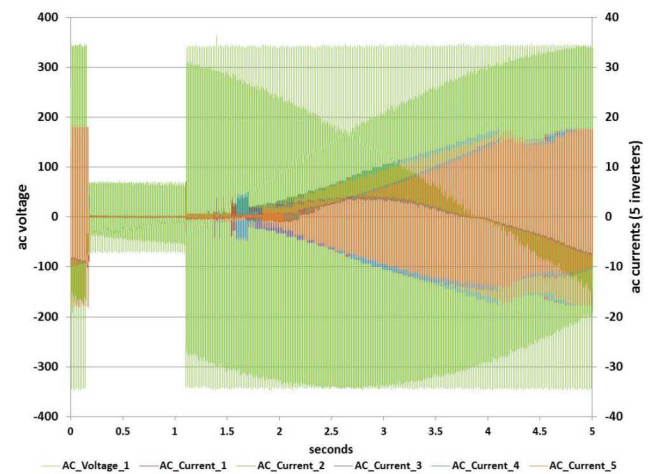

Fig. 4. Voltage < 50% of nominal ride through (5-inverter configuration).

#### B. Volt-VAr Evaluation Results

The Volt-VAr function characteristic curve shown in Figure 1 provides nondimensionalized reactive power values

as a function of normalized grid voltage to providing dynamic voltage regulation. Following the Volt-VAR curve characteristic, the inverter will produce more reactive power as the voltage sags/surges beyond  $V_{nom}$ . A deadband between 98% and 102% of 240 V<sub>ac</sub> was programmed into the volt-VAR curve. Figure 5 shows the volt-VAR evaluation on five inverters configured as shown in Figure 2. Note that the reactive power is unsigned in Figure 5. All of the inverters respond within 1 volt of each other and maintain the same slope as ac voltage decreases and increases. The inverters started to inject reactive power in support of the voltage at roughly  $\pm 3\%$ , which is within the 2% deadband plus 2% manufacturers stated accuracy.

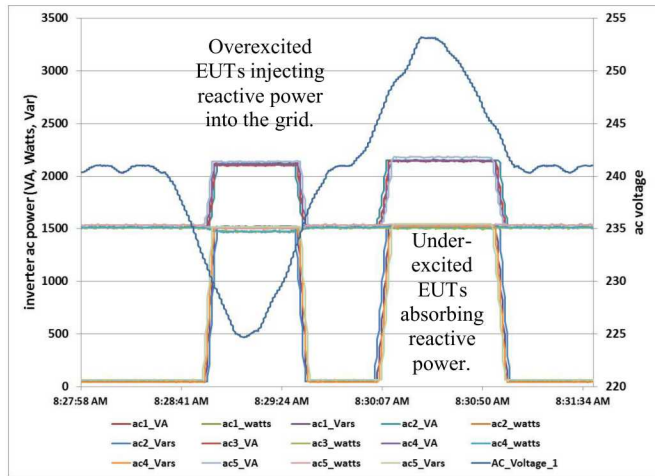

Fig. 5. Volt-VAR evaluations conducted on five inverters.

Figure 6 shows multiple inverters tied to a PCC as would be the case on a residential pad-mount transformer feeding multiple homes. Monitoring the ac line voltage correctly with multiple inverters connected in this configuration is a challenge. The high-frequency noise injected by each inverter can complicate the fundamental voltage measurement and increase the measurement error—possibly beyond the manufacturer’s stated accuracy percentage.

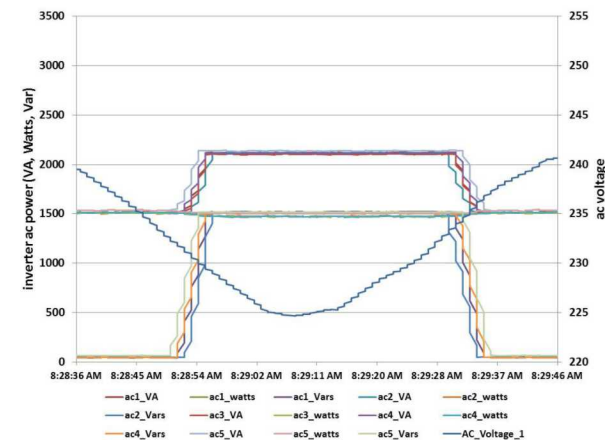

Fig. 6. Detailed five-inverter volt-VAR test results.

Another voltage-regulation function is the commanded PF, i.e., displacement factor, and may include a ramp rate and a delay time before initiating. This function can be set autonomously by following a scheduled PF profile or the function can be enabled using a communicated command. The new utility interconnection draft standard now requires the DERs to deliver rated real power at a 0.9 PF. It should be kept in mind, during low irradiance conditions and low power levels, PF is undefined.

The DER’s ability to maintain a commanded VAR-priority PF at rated power was evaluated, and a more challenging requirement of maintaining the PF under dynamic irradiance conditions was also evaluated. This evaluation used an irradiance profile from the Sandia Interoperability Test Protocol [10] that provided a low and high irradiance ramp rates to thoroughly evaluate the DER PF capability. Figure 7 shows the result of the inverters maintaining a programmed to the most aggressive setting of 0.8 PF. With fluctuating dc power, the inverter must have a closed-loop PF control to maintain the target PF setting. Additional PF tests using the irradiance profile were conducted by three Smart Grid International Research Facility Network (SIRFN) laboratories [5]

Other voltage regulation functions such as the voltage-watt function and commanded reactive power function are not part of this evaluation primarily because these functions are optional in Rule 21 Phase 1. The voltage-watt function is a voltage-triggered management of the DER power used to smooth voltage deviations by increasing or reducing real power output of the DER. The commanded reactive power function sets the reactive power delivered by the DER to a constant level at either the PCC or the DER electrical connection point.

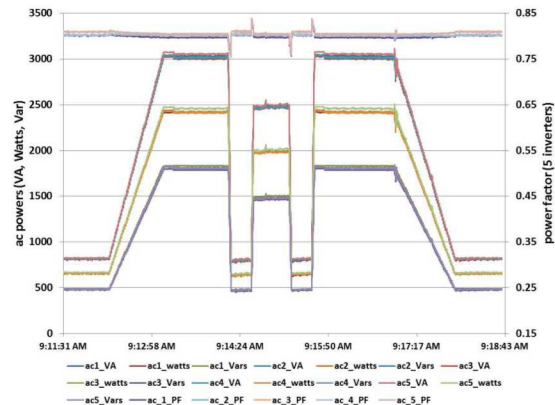

Fig. 7. PF evaluation with varying dc/ac power.

### C. Frequency-Watt Evaluation Results

Grid frequency deviations can be mitigated by triggering a frequency regulating function that manages the DER real power generation and will increase the real power generation when a low-frequency event is detected and reduce real power generation when real power generation a high-frequency event is detected. These actions are taken during emergency

conditions or during the smoothing of oscillatory conditions of bulk power system or microgrid.

There are two methods, single- or multiple-curve methods, of implementing the frequency-watt function and both adjust DER real power generation in response to frequency anomalies. The curve (shown in Figure 8) limits the maximum watt output as a function of frequency using a gradient (WGra), frequency start (HzStart), hysteresis frequency stop (HzStop) which allows the power to return to rated power ( $P_M$ ), and function enable (HysEna). In the case of the hysteresis option, the real power generation remains depressed until the stop value is reached. The settings used in these evaluations utilized a single-curve method without hysteresis.

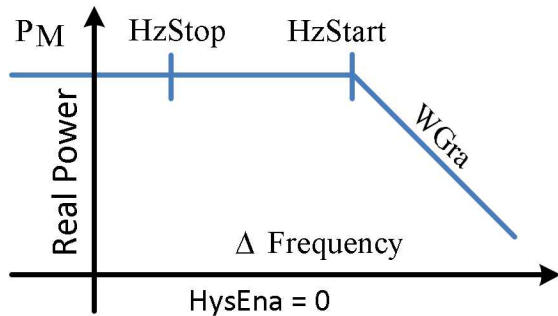

Fig. 8. Single frequency-watt curve.

With the frequency-watt curve implemented into all five inverters, the inverter responses were analyzed during multiple frequency deviations. As shown in Figure 9, an over-frequency variation was programmed into the ac simulator and the real power generation from each inverter decreased depending on the severity of the deviation. The frequency deviations were repeated and the inverter responded accordingly. As the frequency returned to nominal, the real power generation for each inverter returned to rated power levels, indicating high precision for inverter frequency-watt functions.

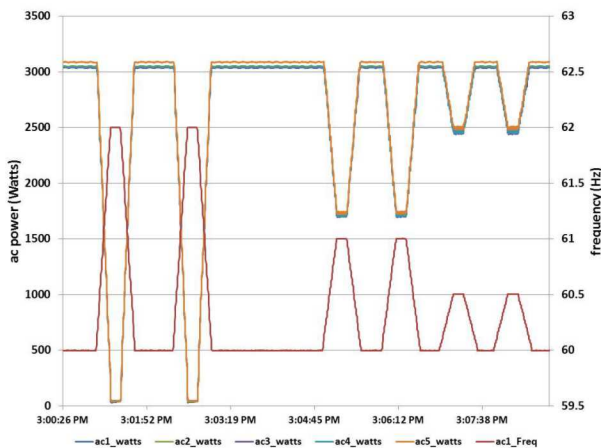

Fig. 9. Frequency-watt results with high-frequency deviation.

A low-frequency event can be supported by using the inverter controls to command an increase in power generation. However, if the inverter is already at rated power, it can't increase power unless one of these possibilities exists:

- Inverter overrides a real power curtailment command.
- Inverter has storage capability and inverter can operate above rated power for short durations.

The low-frequency event evaluation with the inverters operating at 50% of rated power through a commanded curtailed operation is shown in Figure 10. For this test, the dc supply was sufficient to operate the inverters at rated power and when the low-frequency event was executed, the inverter would not override the power curtailment. This is a capability that is being investigated with the inverter manufacturer.

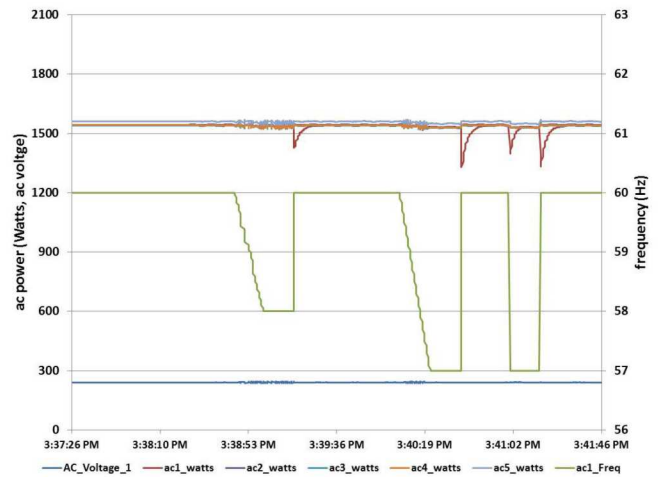

Fig. 10. Frequency-watt results with low-frequency deviation.

#### D. Unintentional Islanding Preliminary Results

Utility interconnected PV inverters must adhere to utility interconnection standards that require the inverter to recognize when the utility has experienced an interruption in service and cease energizing within 2 seconds. Modern inverters are able to meet this requirement without much of an issue, but with the higher RE penetration levels and new EPS support functions, meeting the unintentional islanding criteria is again becoming a concern from utility-protection engineers, system integrators, and inverter manufacturers.

The EPS support functions require the DER devices to ride-through voltage and frequency deviations that used to cause the devices to shutdown. The dynamic-voltage and frequency-regulating functions complicate the situation even further. Unintentional islanding algorithms, like Sandia's voltage and frequency shift, will either have to become more aggressive or an alternative method must be developed to become compliant with the loss-of-utility detection requirements.

Unintentional islanding testing, with the new EPS support functions enabled, has become a process that involves quantifying the support functions and enabling these functions to the most aggressive settings, with the minimum and

maximum voltage and frequency operating ranges and ride-through. Due to the number of functions that may be enabled simultaneously, the permutations are extensive, and the number of tests in UL 1741 has increased considerably. Further complicating the certification tests, if the EUT fails a particular combination of enabled functions, the suspect function will have to be modified and requantified, and the islanding test must be rerun with that particular combination of functions. Figure 11 shows the results of an extensive islanding test with the L/HVRT, L/HFRT, volt-VAr, and frequency-watt functions enabled and set to their most aggressive settings.

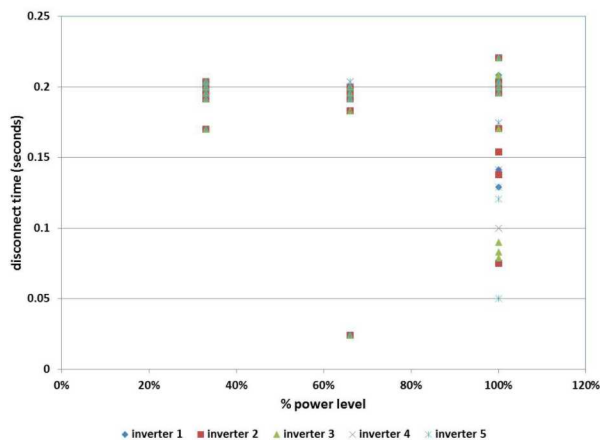

Fig. 11. Unintentional islanding test results with five inverters.

#### IV. CONCLUSIONS

Inverters with EPS support functions will need to be implemented in large numbers in order to realize DOE’s targeted levels of solar penetration. Thoroughly documenting the capabilities and finalizing draft UL 1741 Supplemental A test standards for utility interconnection requirements and safety listing are needed to correctly set EPS support-function parameters. This paper reports on the capabilities of EPS support functions and follow-up work will investigate the interactions of multiple-inverter configurations.

#### ACKNOWLEDGMENTS

Sandia National Laboratories is a multi-program laboratory managed and operated by Sandia Corporation, a wholly owned subsidiary of Lockheed Martin Corporation, for the U.S. Department of Energy’s National Nuclear Security Administration under contract DE-AC04-94AL85000. This material is based upon work supported by the U.S. Department of Energy SunShot program under Award Number 29094.

#### REFERENCES

[1] National Renewable Energy Laboratory and U.S. Department of Energy. “SunShot Vision Study.” Feb. 2012. See: <http://energy.gov/eere/sunshot/sunshot-vision-study>.

[2] IEEE 1547 Std. 1547-2008, “IEEE Standard for Interconnecting Distributed Resources with Electric Power Systems,” Institute of Electrical and Electronics Engineers, Inc., New York, NY

[3] California Public Utilities Commission, “Recommendations for Updating the Technical Requirements for Inverters in Distributed Energy Resources, Smart Inverter Working Group Recommendations,” Jan 2014.

[4] Underwriters Laboratories 1741 Ed. 2, “Inverters, Converters, Controllers and Interconnection System Equipment for use with Distributed Energy Resources,” 2010.

[5] J. Johnson, R. Bründlinger, C. Urrego, R. Alonso, “Collaborative Development Of Automated Advanced Interoperability Certification Test Protocols For PV Smart Grid Integration,” EU PVSEC, Amsterdam, Netherlands, 22-26 Sept, 2014.

[6] J. Johnson, B. Fox, “Automating the Sandia Advanced Interoperability Test Protocols,” 40th IEEE PVSC, Denver, CO, 8-13 June, 2014.

[7] J.C. Neely, S. Gonzalez, M. Ropp, D. Schutz, Accelerating Development of Advanced Inverters: Evaluation of Anti-Islanding Schemes with Grid Support Functions and Preliminary Laboratory Demonstration, Sandia National Laboratories Technical Report, SAND2013-10231, Nov. 2013.

[8] S. Gonzalez, J. Neely, M. Ropp, "Effect of non-unity power factor operation in photovoltaic inverters employing grid support functions," 40th IEEE PVSC, 8-13 June 2014.

[9] S. Gonzalez, J. Stein, A. Fresquez, M. Ropp, D. Schutz, "Performance of utility interconnected photovoltaic inverters operating beyond typical modes of operation," 39th IEEE PVSC, 16-21 June 2013.

[10] J. Johnson S. Gonzalez, M.E. Ralph, A. Ellis, and R. Broderick, “Test Protocols for Advanced Inverter Interoperability Functions,” Sandia Technical Report SAND2013- 9880 and SAND2013-9875, Nov. 2013.