

UVIG Short Course on the Integration and Interconnection of Variable Generation into Power Systems

September 18-21 2012
Albuquerque, NM

Session 13 – Solar Plant Model Development and Validation

Abraham Ellis
aellis@sandia.gov



Outline

- Why do we care about models?
- Power Flow and Dynamic Models
 - Large Plants
 - Distributed PV
- Short Circuit Contribution
- PV Variability

PV Systems Characteristics

- Different than conventional generators
 - Non-dispatchable, variable
 - Collector system
 - Converter interface
 - Current-limited, Zero inertia
- “Programmable”
 - Trip thresholds
 - Reactive power support
 - Active power management*
- Should not be “invisible” to planners



Application of Models

- General Grid Planning/Expansion Studies
 - Test compliance against reliability criteria
 - Models should not be confidential, black-box
- Interconnection Studies
 - Identify system impacts, test mitigation alternatives
- Evaluation of Future High Penetration Scenarios
 - Evolution of standards
 - Technology development needs





What Models are Needed for Transmission-Level Studies?

- Power flow (positive-sequence)
 - Facility loading, static voltage stability & control
- Dynamic (positive-sequence)
 - Large-signal stability, rotor angle stability
- Short circuit
 - Breaker duty, protection design/coordination
- Detailed, full-order, unbalanced
 - Control interaction, SSR, TRV, harmonic analysis, ...



Utility Industry Modeling Needs

- NERC Integration of Variable Generation Task Force (IVGTF) has identified the lack of planning models as major barrier to variable generation integration

“Validated, generic, non-confidential, and public standard power flow and stability (positive-sequence) models for variable generation technologies are needed. Such models should be readily validated and publicly available to power utilities and all other industry stakeholders. Model parameters should be provided by variable generation manufacturers and a common model validation standard across all technologies should be adopted. The NERC Planning Committee should undertake a review of the appropriate Modeling, Data and Analysis (MOD) Standards to ensure high levels of variable generation can be simulated.”

*Reference: NERC Special Report, Accommodating High Levels of Variable Generation,
http://www.nerc.com/files/IVGTF_Report_041609.pdf*

Modeling Requirements in the Interconnection Process

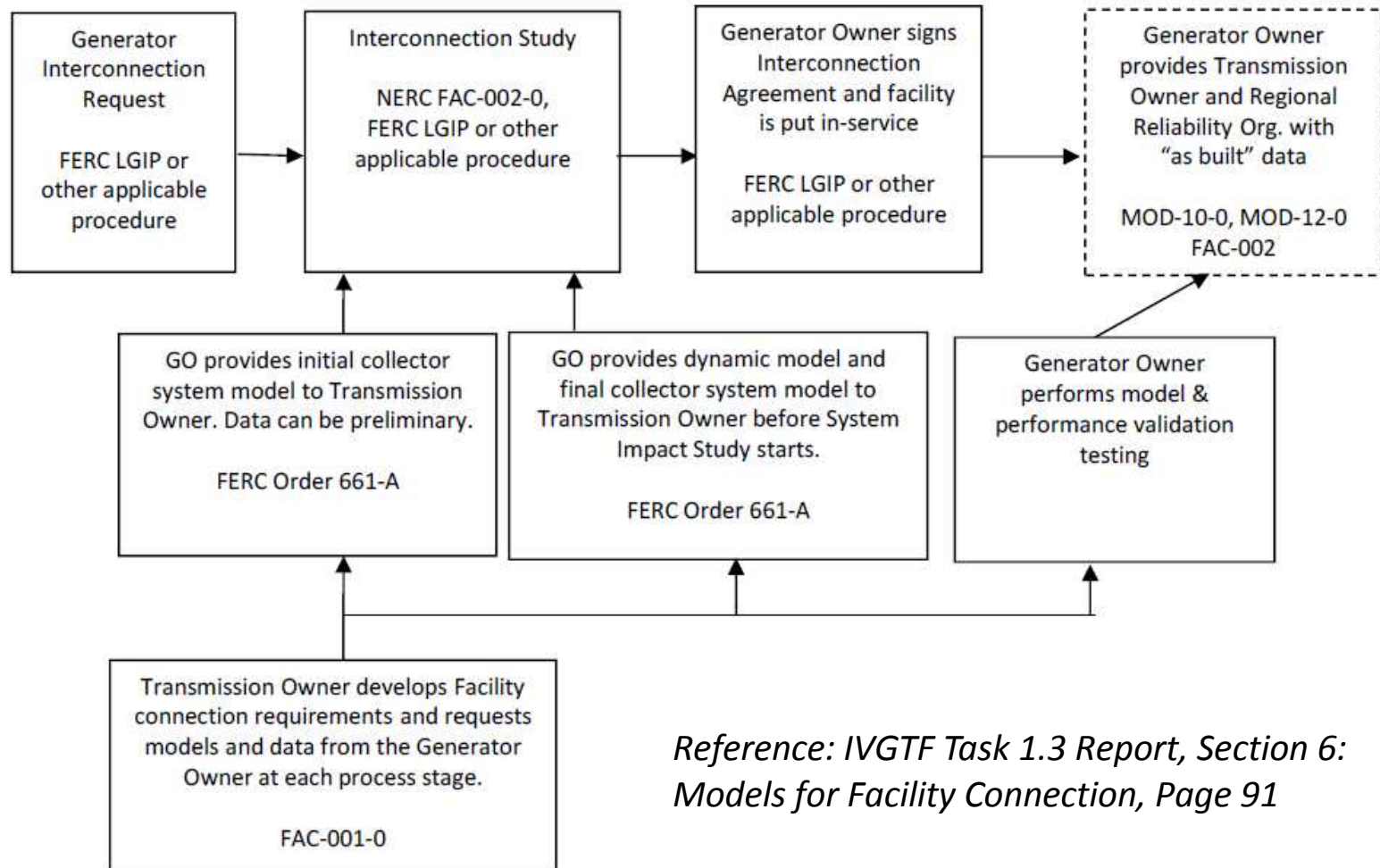

*Reference: IVGTF Task 1.3 Report, Section 6:
Models for Facility Connection, Page 91*



WECC PV Modeling Activities

- WECC Renewable Energy Modeling Task Force
 - Develop validated generic, non-proprietary, positive-sequence power flow and dynamic simulation models for distributed and central-station solar and wind generation for large-scale simulations
 - Issue guidelines, model documentation
 - Coordinate with stakeholders groups
- Participants in WECC REMTF PV modeling effort
 - Utilities, Program Developers, Manufacturers, System Integrators, Consultants, DOE/National Labs (Sandia Labs coordinating)



Power Flow and Dynamic Representation of Large PV Plants

Large-Scale PV Plants

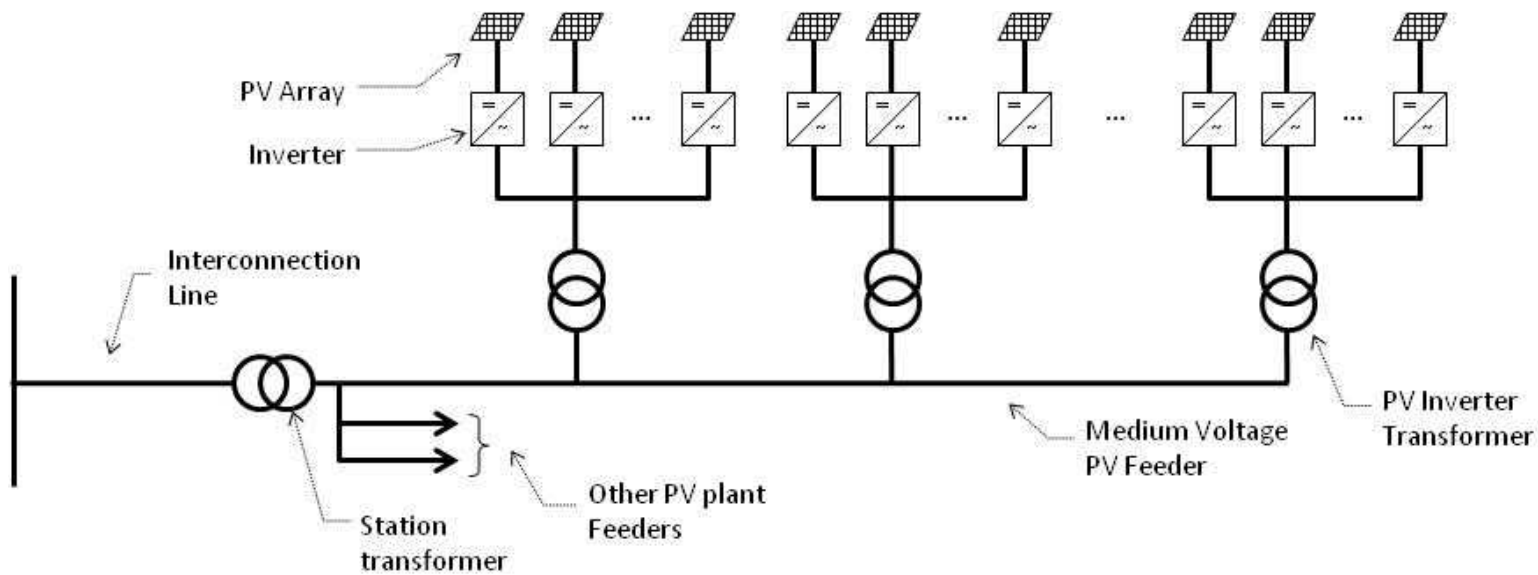

Equivalencing

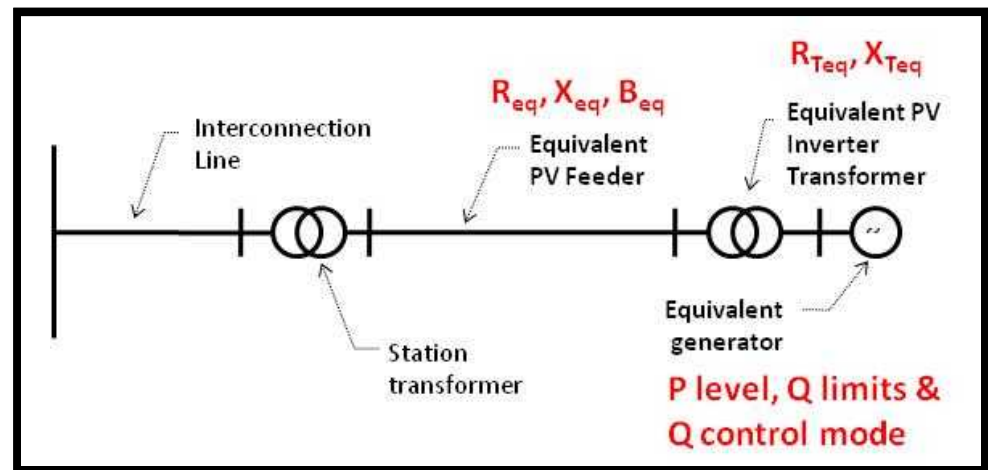

Example – 21 MW PV System

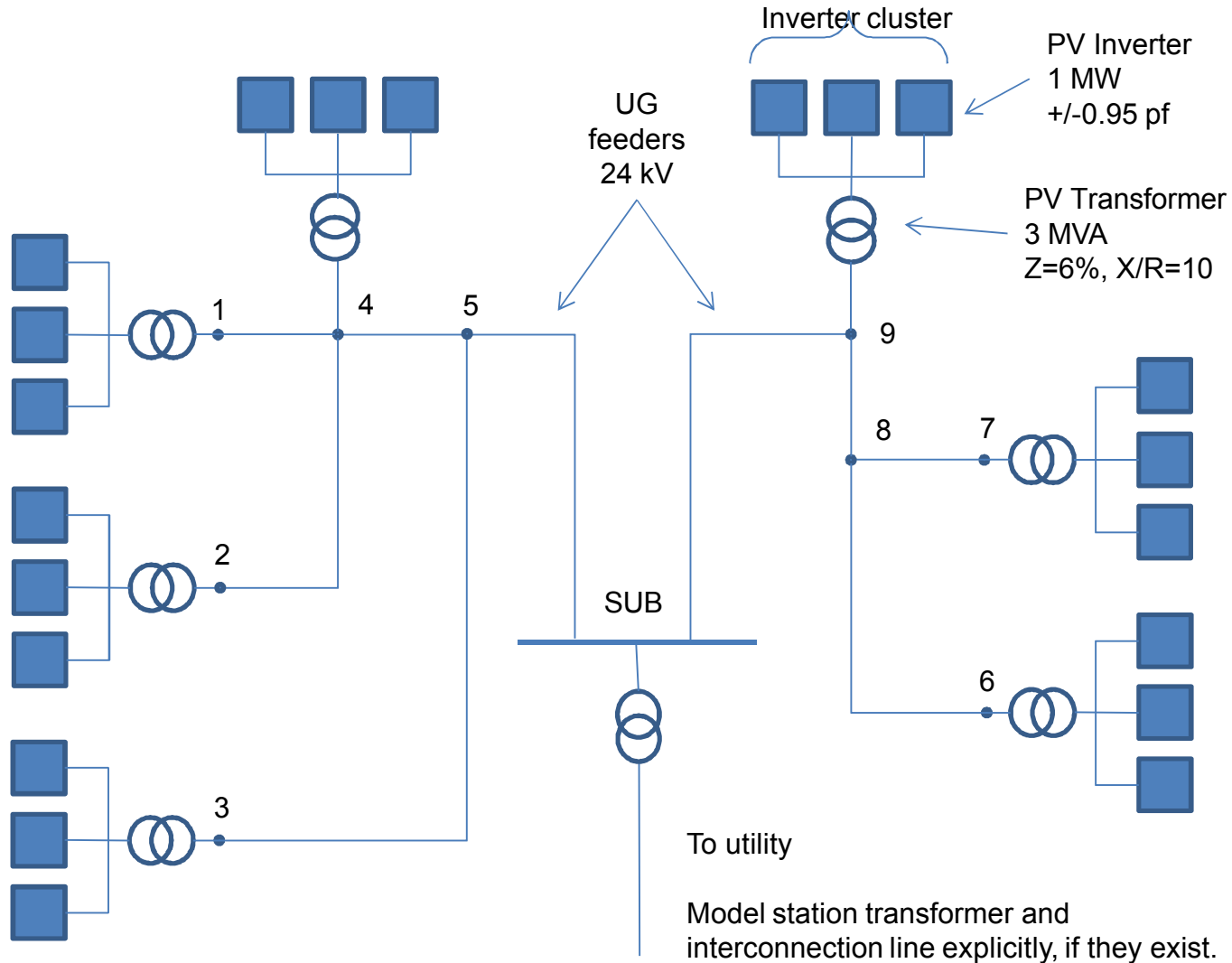

Example – 21 MW PV System

Collector System Equivalent Technique: $Z_{eq} = R_{eq} + jX_{eq} = \frac{\sum_{i=1}^I Z_i n_i^2}{N^2}$ $B_{eq} = \sum_{i=1}^I B_i$

Collector System Equivalent on 100 MVA base, 24 kV

From	To	R	X	B	n	R n ²	X n ²
1	4	0.03682	0.00701	0.000000691	3	0.33136	0.06307
2	4	0.02455	0.00467	0.000001036	3	0.22091	0.04205
4	5	0.02455	0.00467	0.000001036	9	1.98816	0.37843
3	5	0.02557	0.02116	0.000000235	3	0.23016	0.19042
5	SUB	0.02557	0.02116	0.000000235	12	3.68251	3.04673
6	8	0.03747	0.00868	0.000000561	3	0.33726	0.07809
7	8	0.02455	0.00467	0.000001036	3	0.22091	0.04205
8	9	0.02109	0.02501	0.000000199	6	0.75925	0.90025
9	SUB	0.02109	0.02501	0.000000199	9	1.70831	2.02555

RESULTS	
Partial R sum	9.4788
Partial X sum	6.7666
N	21
Collector System Equivalent (Same units as R, X & B data)	
Req	0.021494 pu
Xeq	0.015344 pu
Beq	0.000005 pu

PV Pad-mounted Transformer Equivalent

$$Z_{Teq} = \frac{Z_T}{M} = \frac{0.00597 + j0.05970}{7} = 0.00085 + j0.00853 \text{ pu on 3 MVA base}$$

Reactive Power Capability

Reactive Power Capability of Inverters: What is the reactive power capability? What about partial power?

Reactive Control Options

- Fixed PF/Var setting
- Volt/Var droop
- Closed-loop Voltage Control

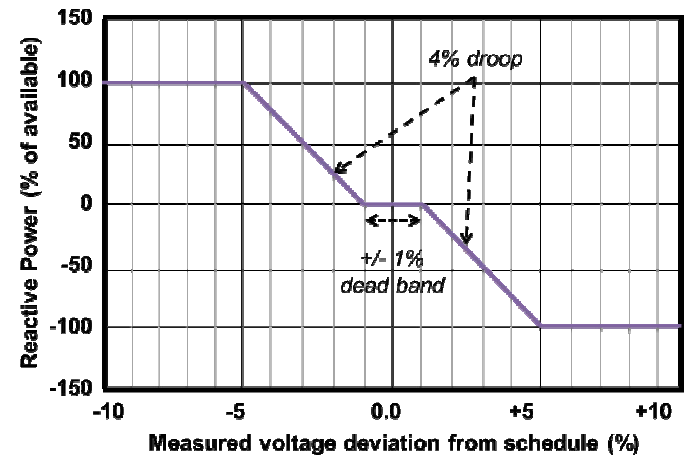
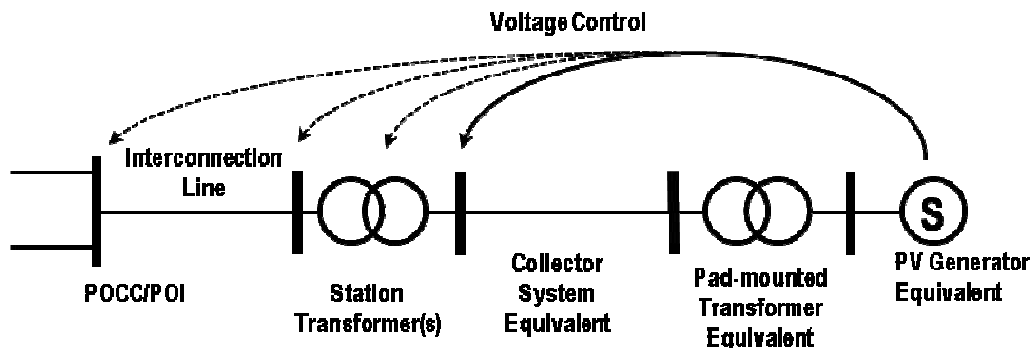
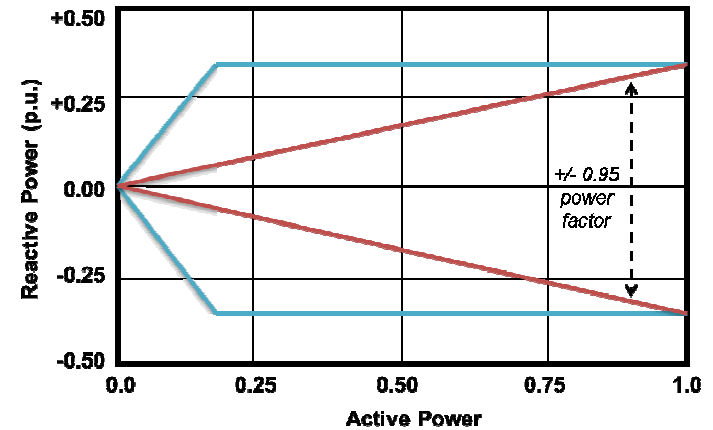

Other NERC IVGTF 1.3 Topics

- Power Flow Modeling

Reference: REMTF, WECC
PV System Power Flow
Modeling Guidelines

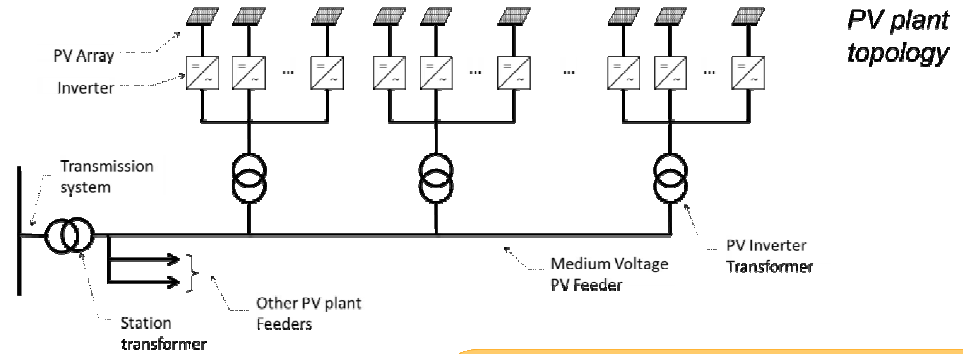

PV plant topology

Single-machine equivalent representation

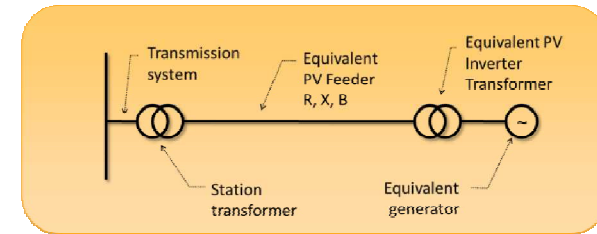

Large PV Plants



Distributed PV (from the point of view of the bulk system)

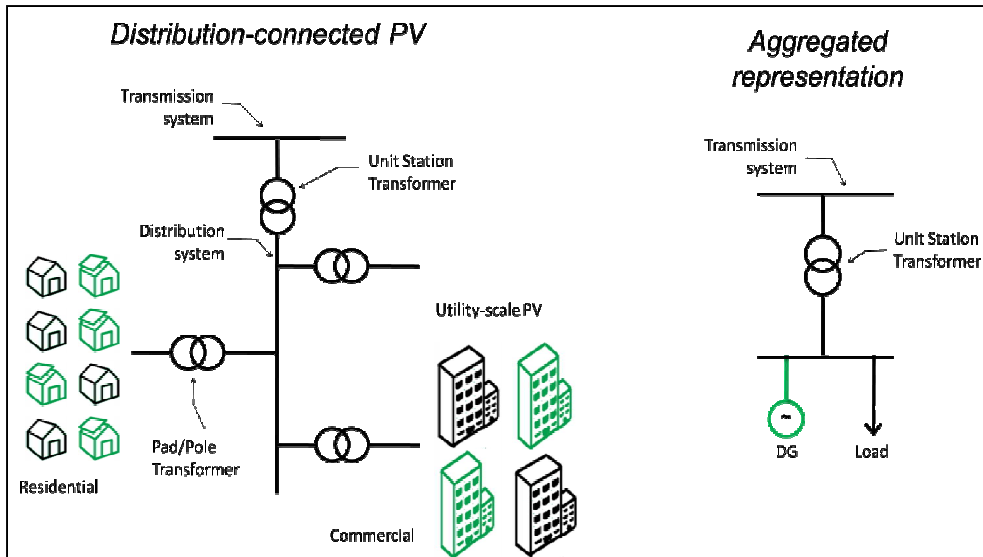

Other NERC IVGTF 1.3 Topics

Dynamic Models

Detailed REMTF generic model for large PV plants

Simplified REMTF dynamic model for small PV plants

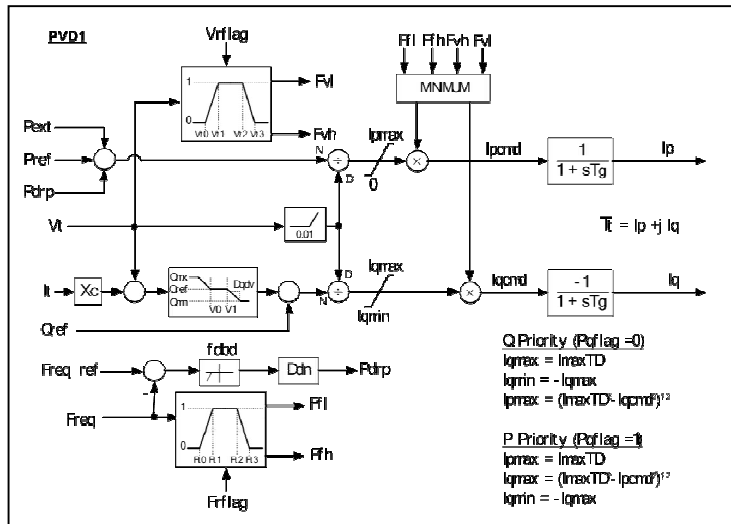
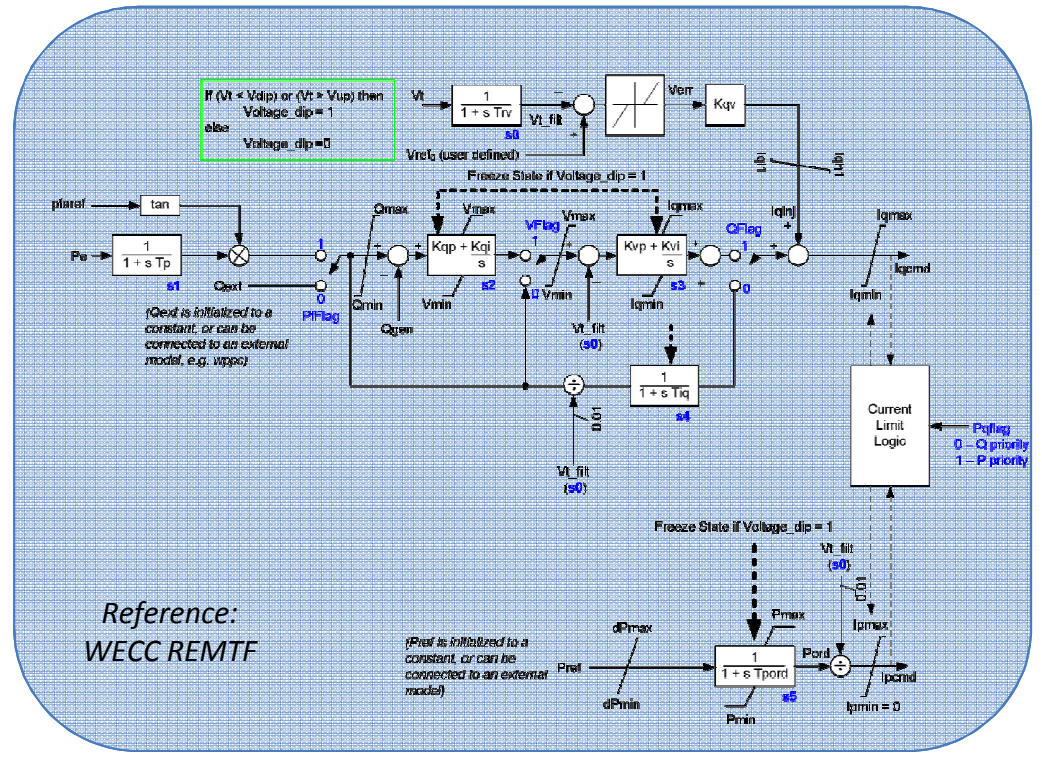
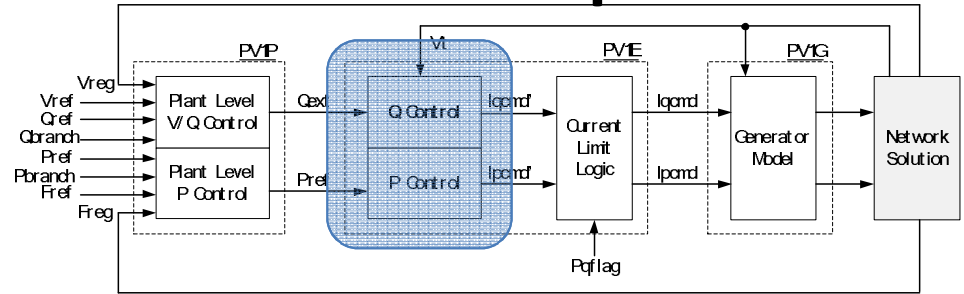

Large PV Plant Modeling

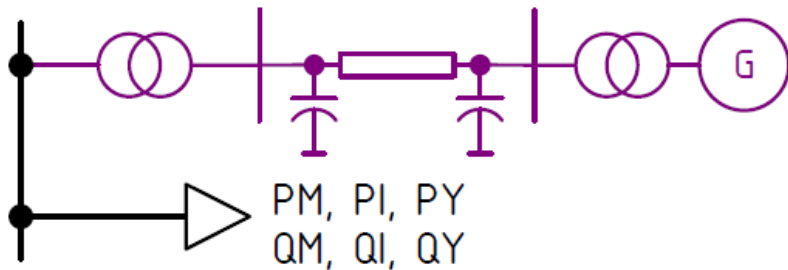

In power flow, PV modeled explicitly as generator ^{Vt}

Should include feeder or collector system equivalent per WECC guide

In dynamics, use stand-alone full-featured or simplified models

Full-Featured

OR

Simplified (PVD1)

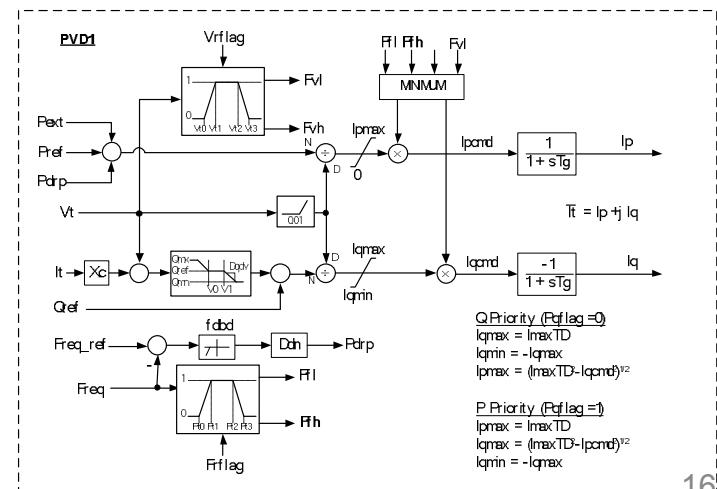
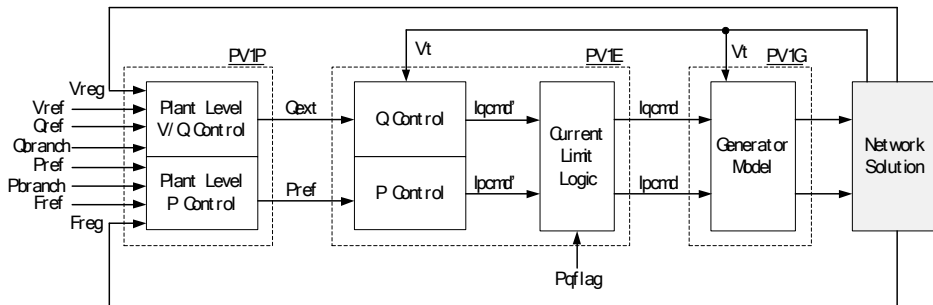

PV1X: Change in Model Structure

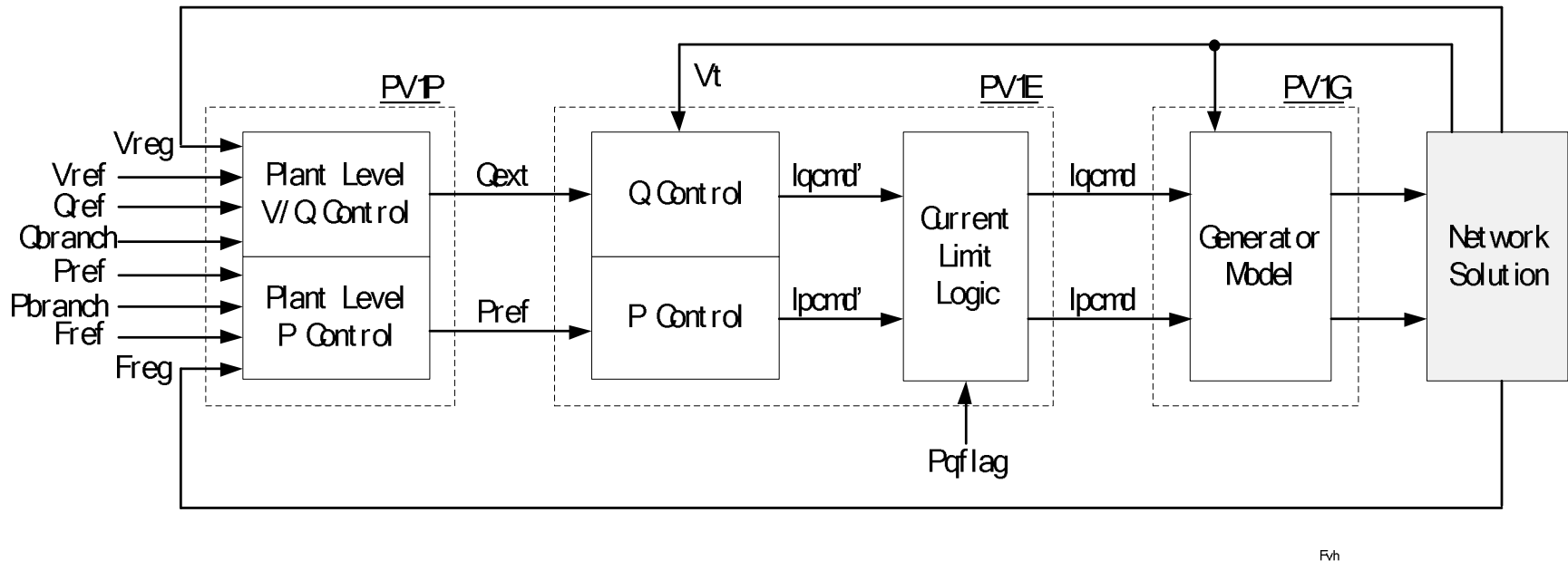

- Plant controller model is optional where remote Volt/VAR and/or plant-level governor response is desired

PV Plant Controller

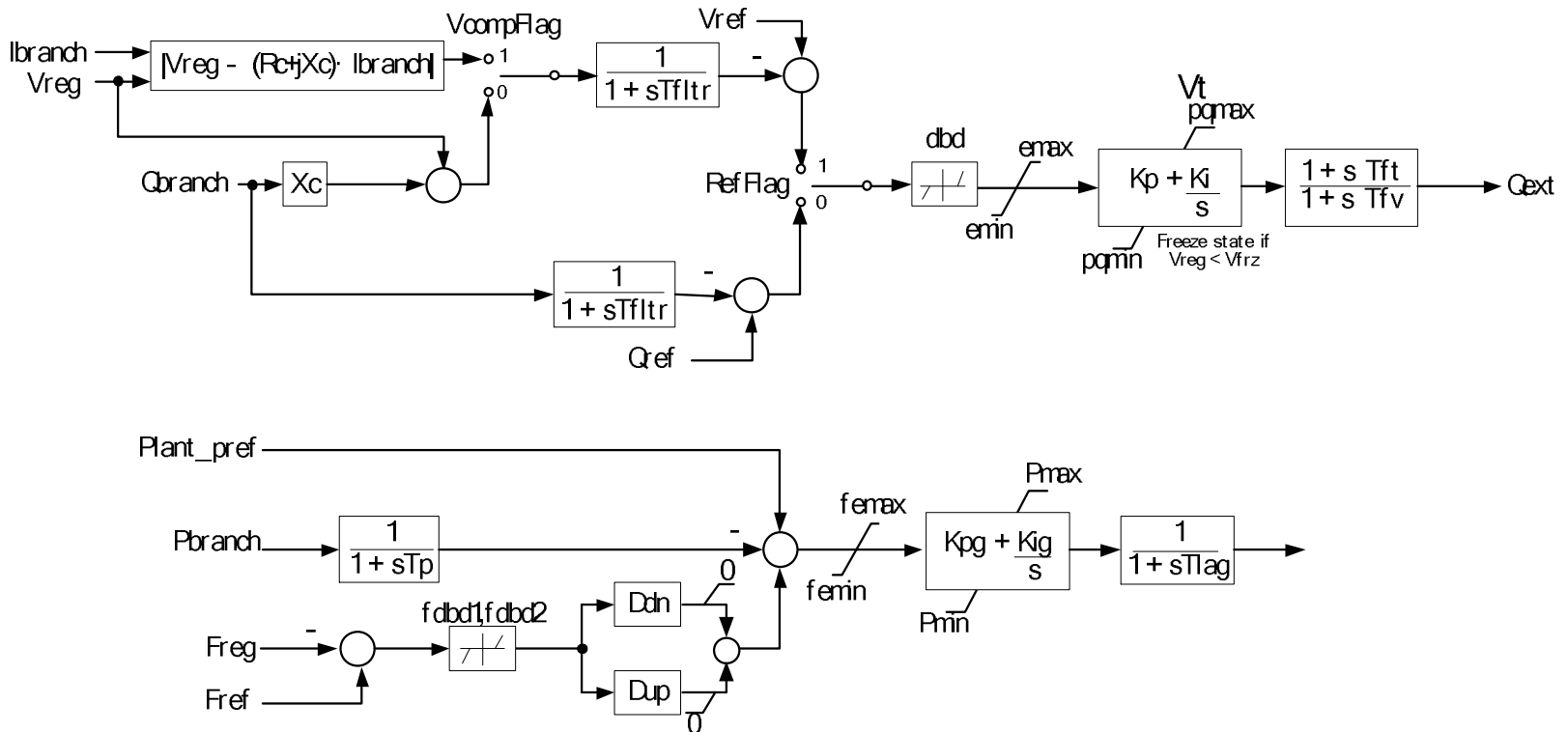

- Same model used to represent plant controllers with WT3 and WT4 WTGs

Simplified Dynamic Model

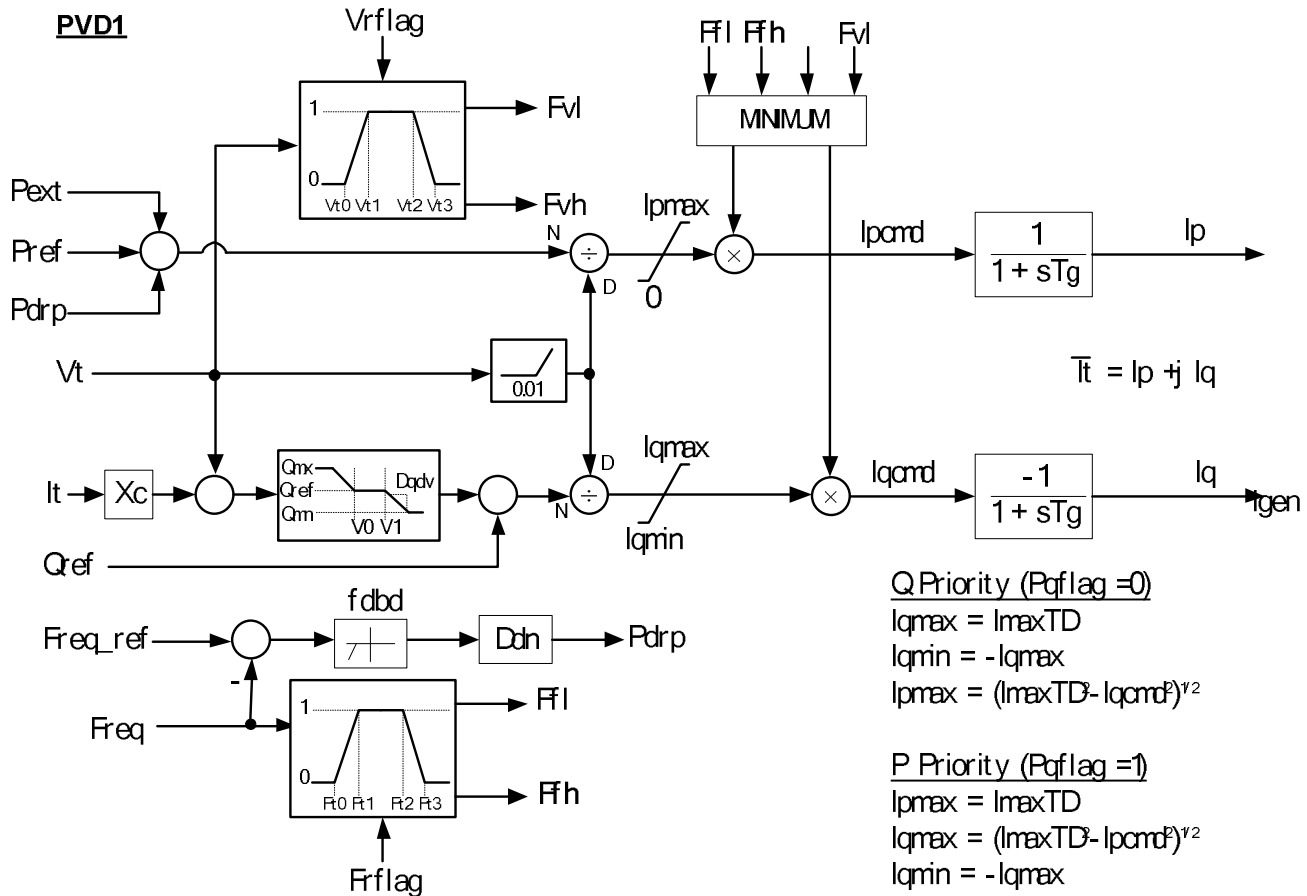



Distribution-Connected PV Modeling

Distributed PV PF Representation

- Need to represent distributed PV in bulk system
 - The challenge is to model the aggregated behavior without too much complexity

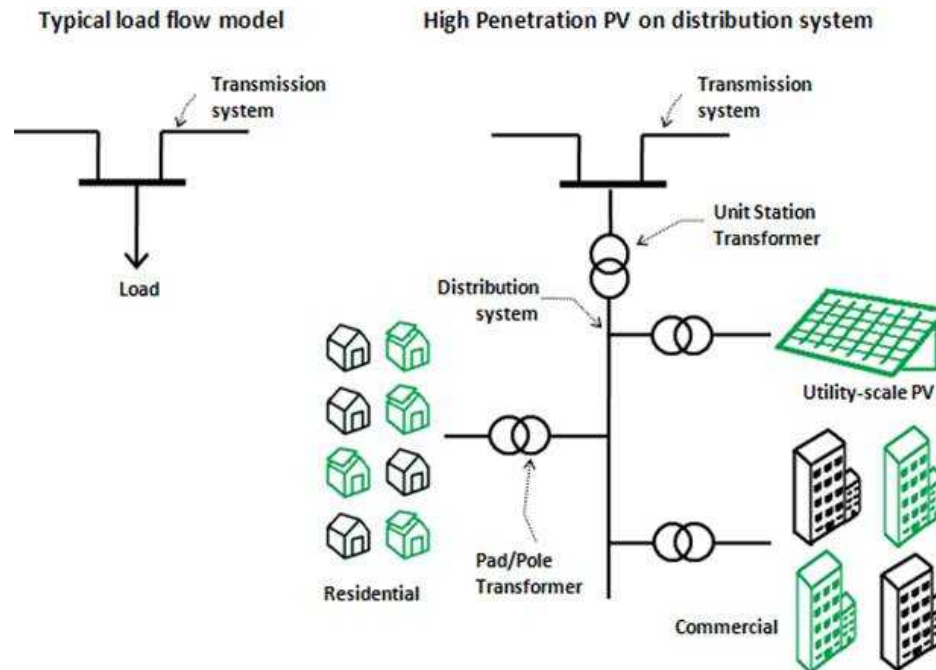

Distributed PV PF Representation

- Use aggregated models
 - Small residential/commercial
 - In load flow, net with bus load
 - For dynamics, augment WECC composite load model
 - Larger, utility-scale systems
 - In load flow, use single-machine equivalent
 - For dynamics, use stand-alone simplified dynamic model

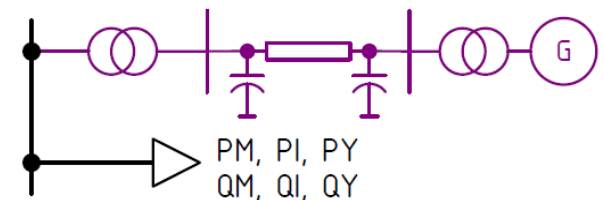
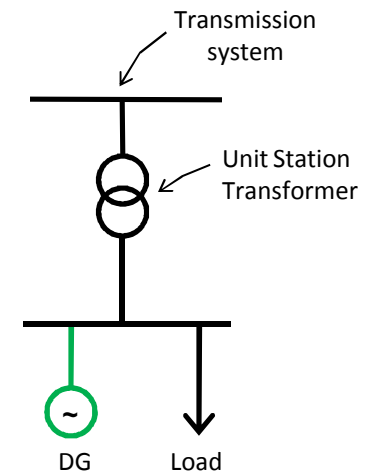
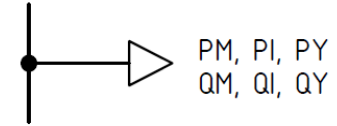

Distributed PV Model Structure

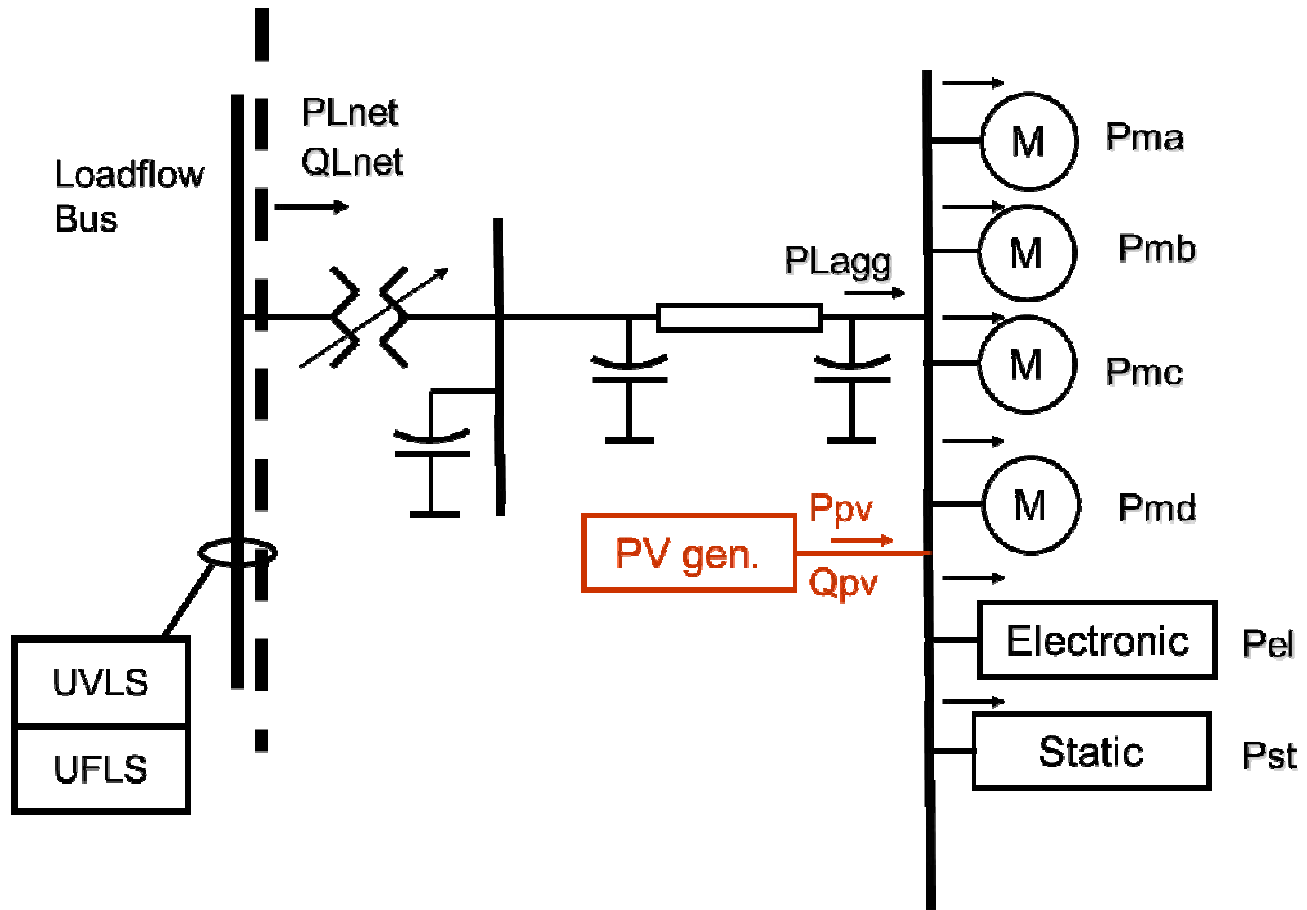

Aggregated PV Dynamic Model

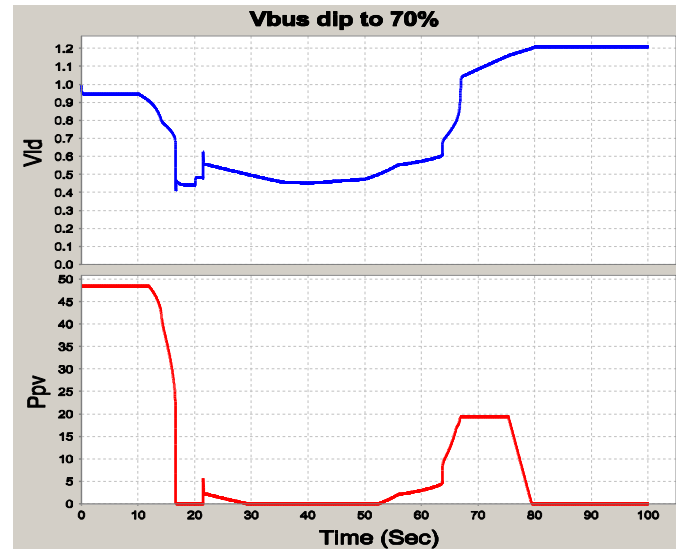
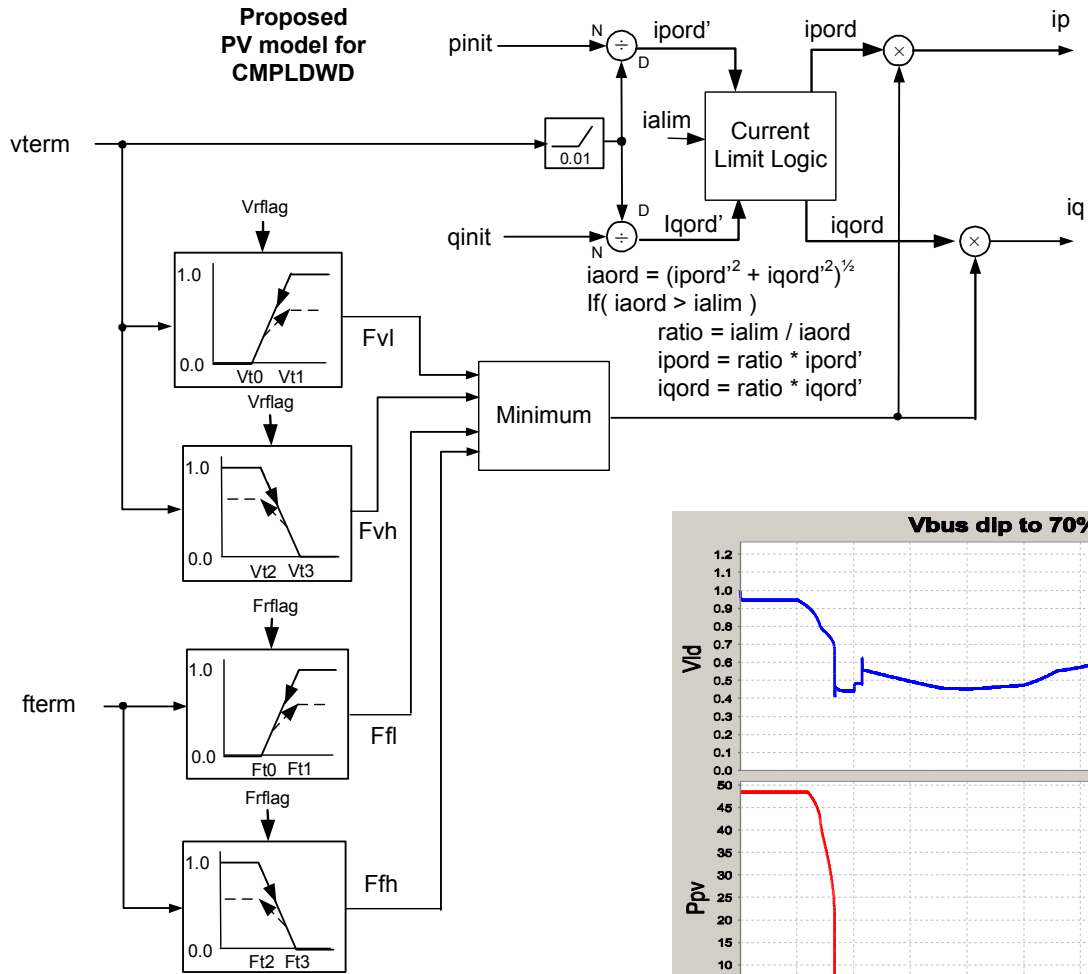

Sample results for

- Mixed load
- 20% PV
- Vbus dip to 70%.
- "vt0pv" 0.5 "vt1pv" 0.8
"vt2pv" 1.1 "vt3pv" 1.2
"vrecpv" 0.4



Work In Progress

- REMTF working on model development and implementation
 - Power Flow Modeling and Dynamic Models
 - Short Circuit Guidelines
- NERC updating standards for regional reliability Planning
 - Model data requirements
 - Periodic validation requirements



Discussion About Plant-Level Model Validation



Event/Test Data Needs

- Validation of models against event/test data is needed
 - To support initial model development work
 - Pursuant to NERC MOD 10/12 and WECC Modeling Procedure
 - Increase confidence in facility connection study process
 - Pursuant to FERC LGIP, NERC FAC-002
 - Comply with network planning procedures
 - Periodic plant model verification per NERC MOD 26/27
 - Note: Some grid codes are more explicit with respect to evidence of model validation
- Quality of data as well as event/test parameters are very important

PV Plant Monitoring with PMUs

- PMU data is useful for model validation.
- Typical SCADA data, even at 1-sec resolution, does not have sufficient detail

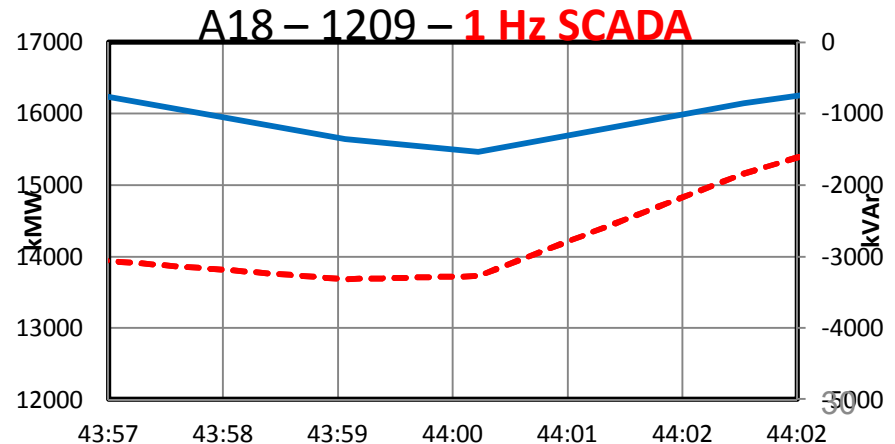
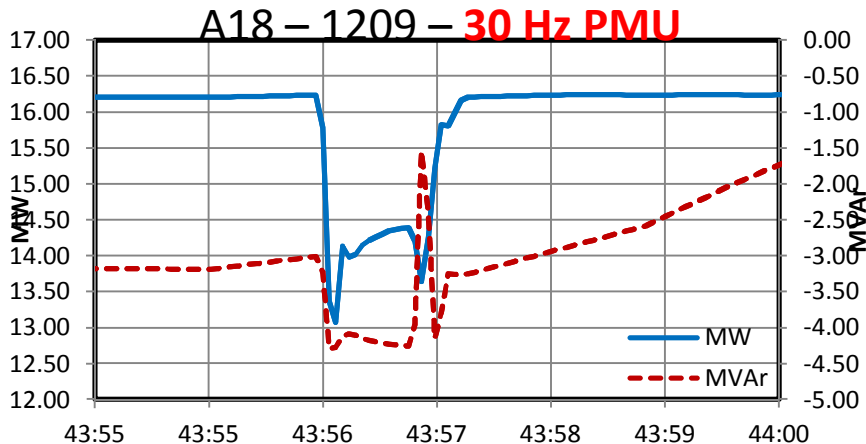
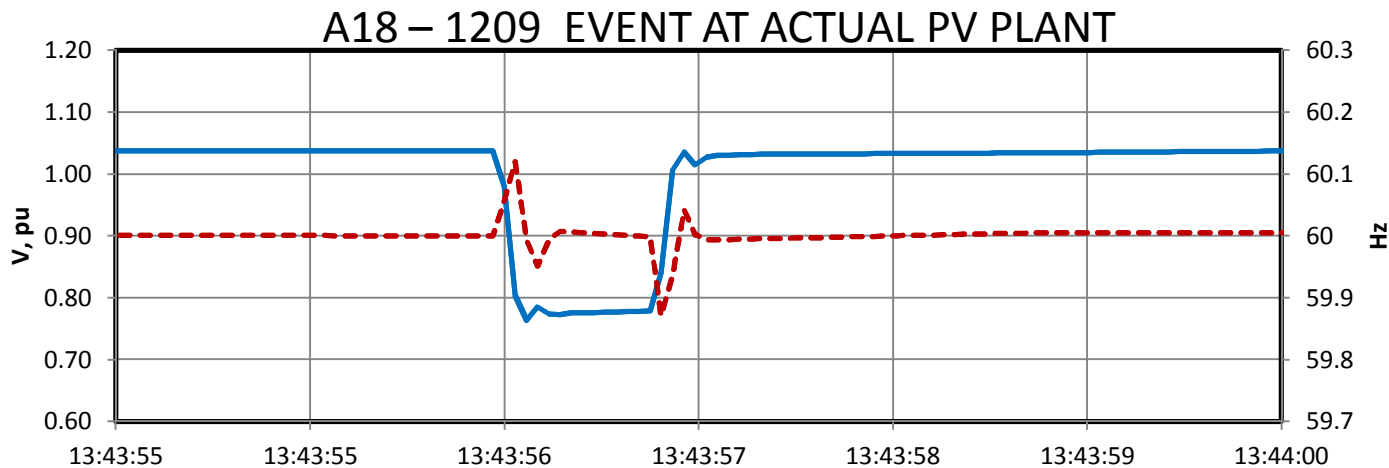



Short Circuit Behavior of PV Plants

Transient Behavior of PV Inverters

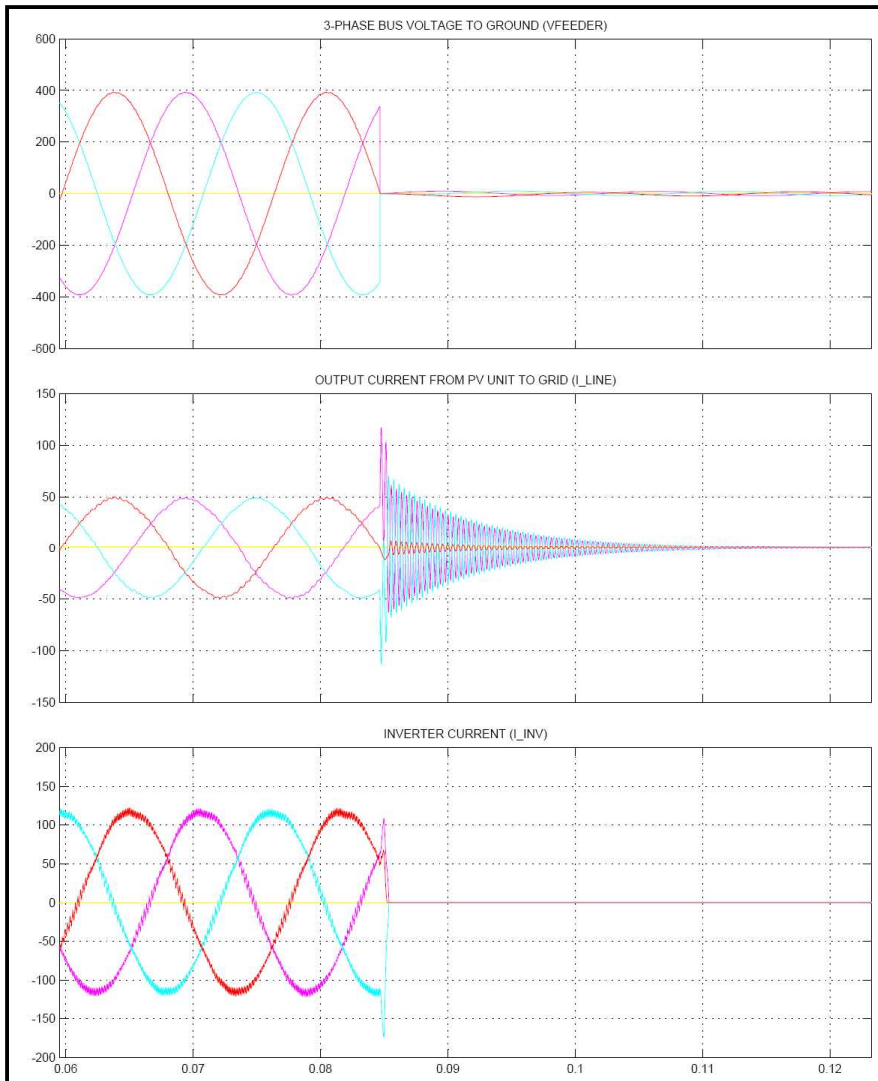

Grid Voltage Monitoring Enabled – Unit Trips During L-L-L-G Fault

In this case the AC voltage drops instantaneously and triggers an “instantaneous AC under-voltage” trip. Inverter gating stops immediately and the AC contactor releases after a few cycles. The filter capacitor rings with the grid inductance for a short time.

Source: Colin Schauder, Satcon Technology Corporation - Transient Modeling for Inverter-Based Distributed Generation, March 2, 2010

Transient Behavior of PV Inverters

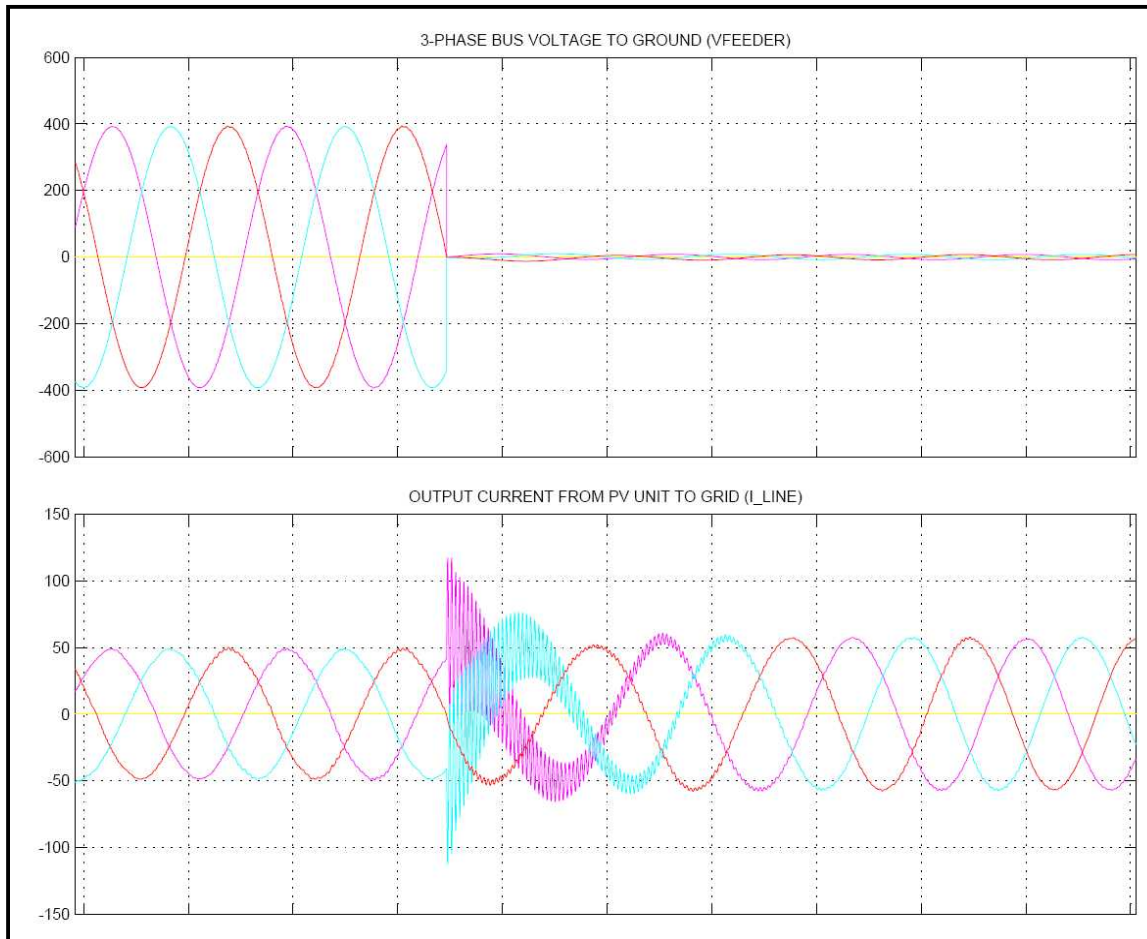

Grid Voltage Monitoring Disabled to Allow Ride-Through During L-L-L-G Fault

In this case the grid voltage monitoring has been disabled so the inverter keeps running (with limited 60 Hz current output).

Note the high frequency resonant discharge of the filter capacitor.

If the voltage drop is not so abrupt, then much less ringing occur.

Source: Colin Schauder, Satcon Technology Corporation - Transient Modeling for Inverter-Based Distributed Generation, March 2, 2010

Short Circuit Current Contribution

- Current limits vary
 - 110% to 150%
 - Typically symmetrical
- Some grid codes further specify SC behavior
 - VRT levels
 - Current Vs. voltage characteristic
 - Active/reactive current priority
- In addition, fault current depends on other factors
 - Type of fault, transformer connections, etc.

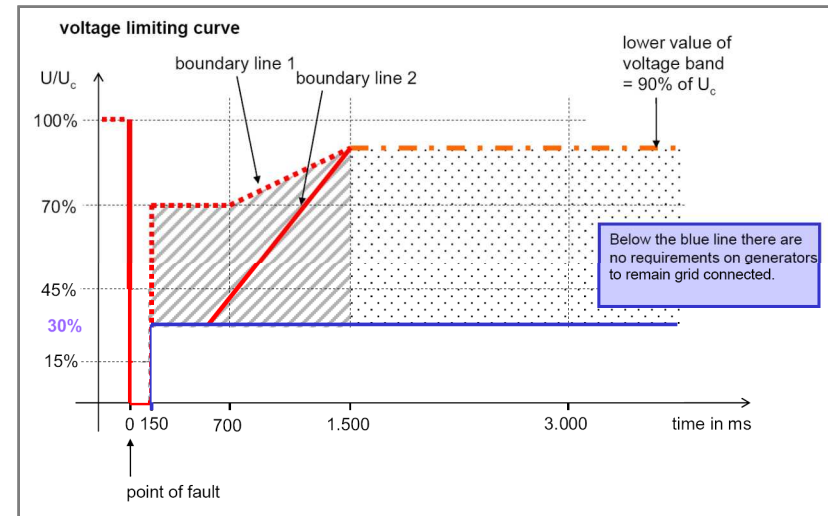



Presentation Outline

- Importance of Short Circuit Analysis in DG Interconnection and Integration
- Synchronous Generator Short Circuit Characteristics
- PV Inverter Short Circuit Characteristics
- Status of Commercial Analysis Tools
- Conclusions



Purpose of Short Circuit Analysis

- Power system faults (short circuit, ground faults) cannot be eliminated
- Utility protection systems must be designed to clear faults through interruption of the source(s) and post-clearing restoration of service to as many customers as possible
- Short circuit analysis aids in achieving these objectives by:
 1. Quantifying the magnitude of fault current through interrupting devices (circuit breaker, fuses, reclosers) to ensure that interrupting capacities are adequate for fault clearance
 2. Providing a basis for protection coordination so that the device(s) that interrupt the fault are the ones that minimize loss of load (selectivity)

Synchronous Generator Short Circuit Character

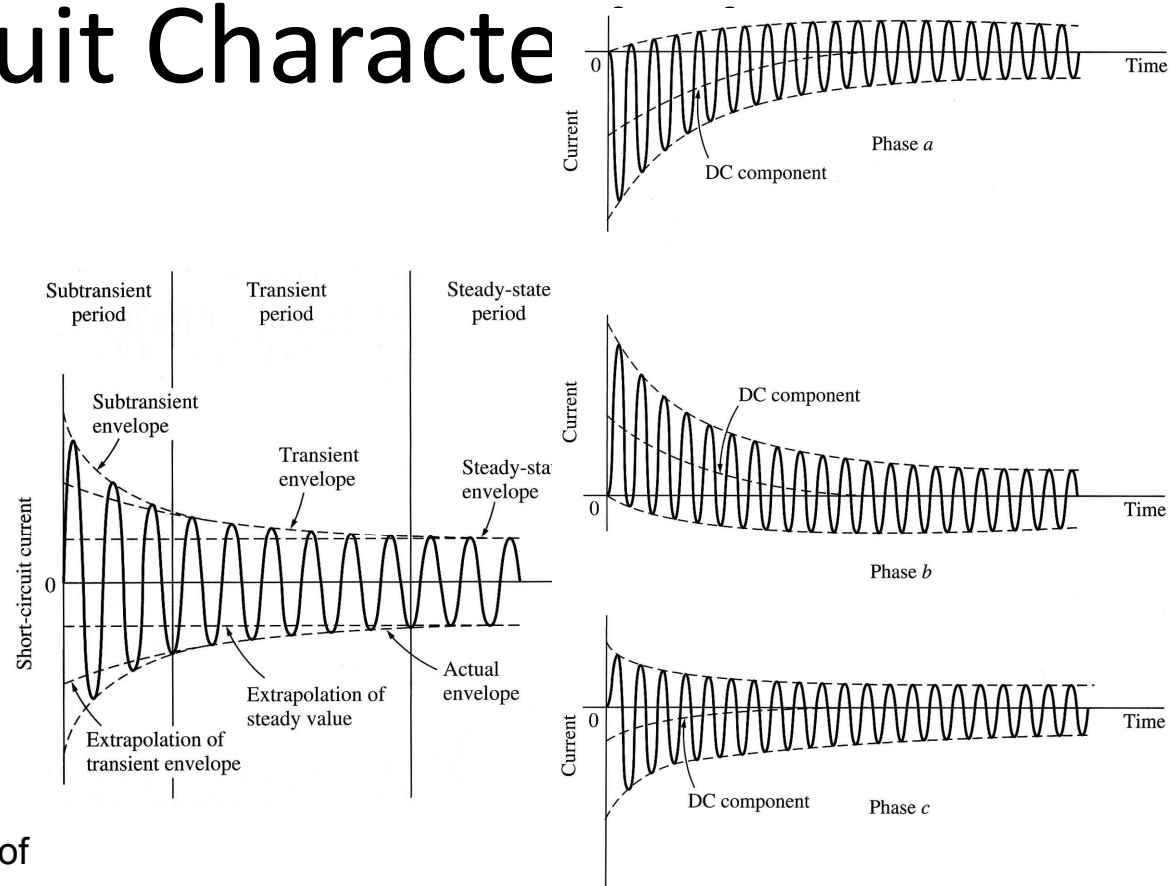

Decay of
damper
winding
transient

Decay of
field
winding
transient

Source: Chapman, Electric Machinery
and Power System Fundamentals, 2002

Synchronous Generator Short

Circuit Characteristics

- Time-variant representation of generator with three separate time-invariant models
- Allows for equivalent representation of generator with complex impedance and appropriate reactance for time period of interest (X_d and X_q) for balanced faults
- Apply $X_d = 0$ for unbalanced faults
- Short circuit calculation methods presented in ANSI and IEC standards

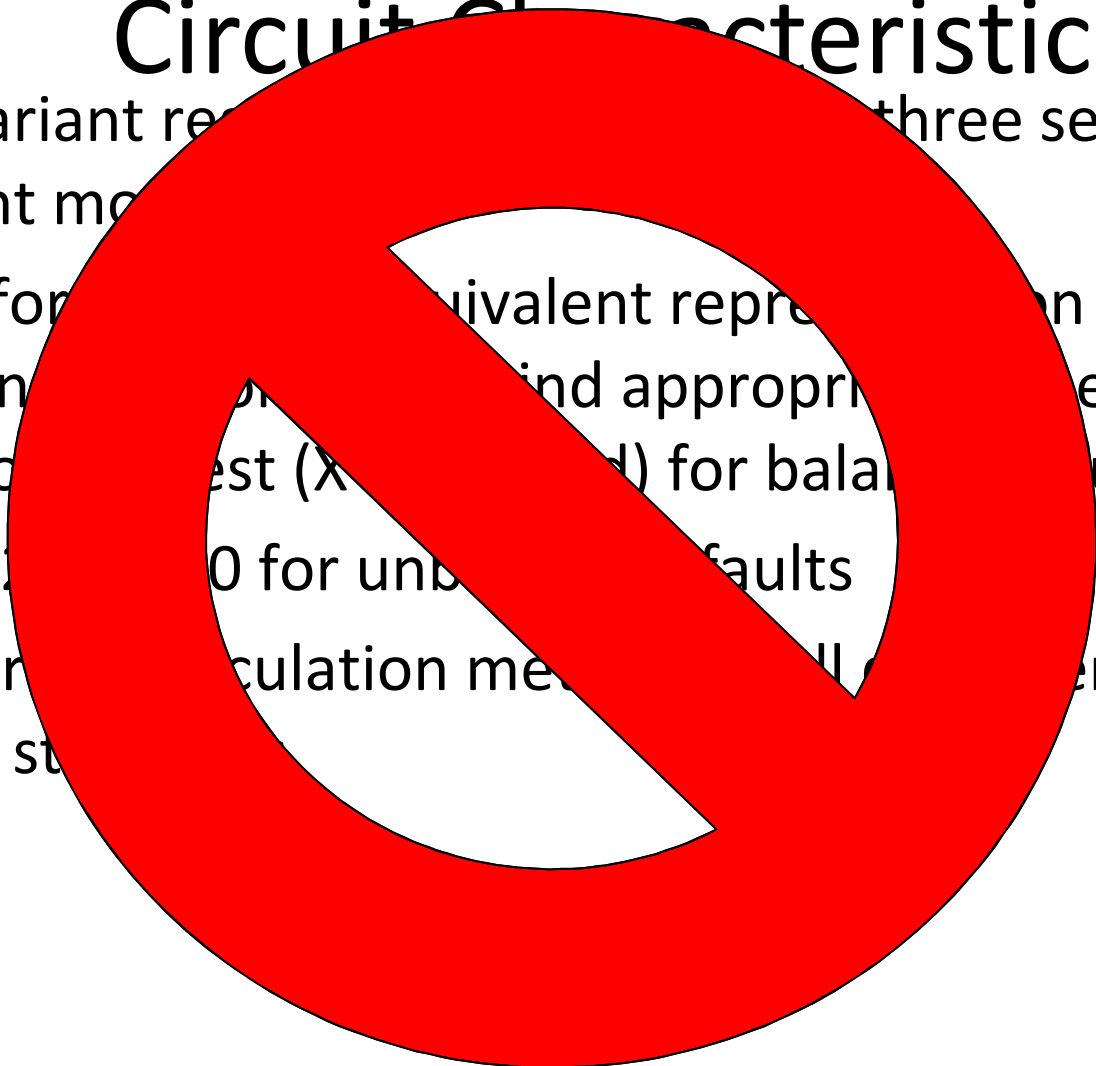



DG Inverter Short Circuit

Characteristics

IMPORTANT CAVEAT:

- We will be talking about a certain class of inverters:
 - 3-phase
 - Voltage source topology
 - High-frequency pulse width modulated (PWM)
 - AC current regulated
- This describes nearly all inverter models currently being applied in utility and commercial scale DR
- Some inverters (particularly some PV micro-inverters) do not fall into this class

DG Inverter Short Circuit Characteristics

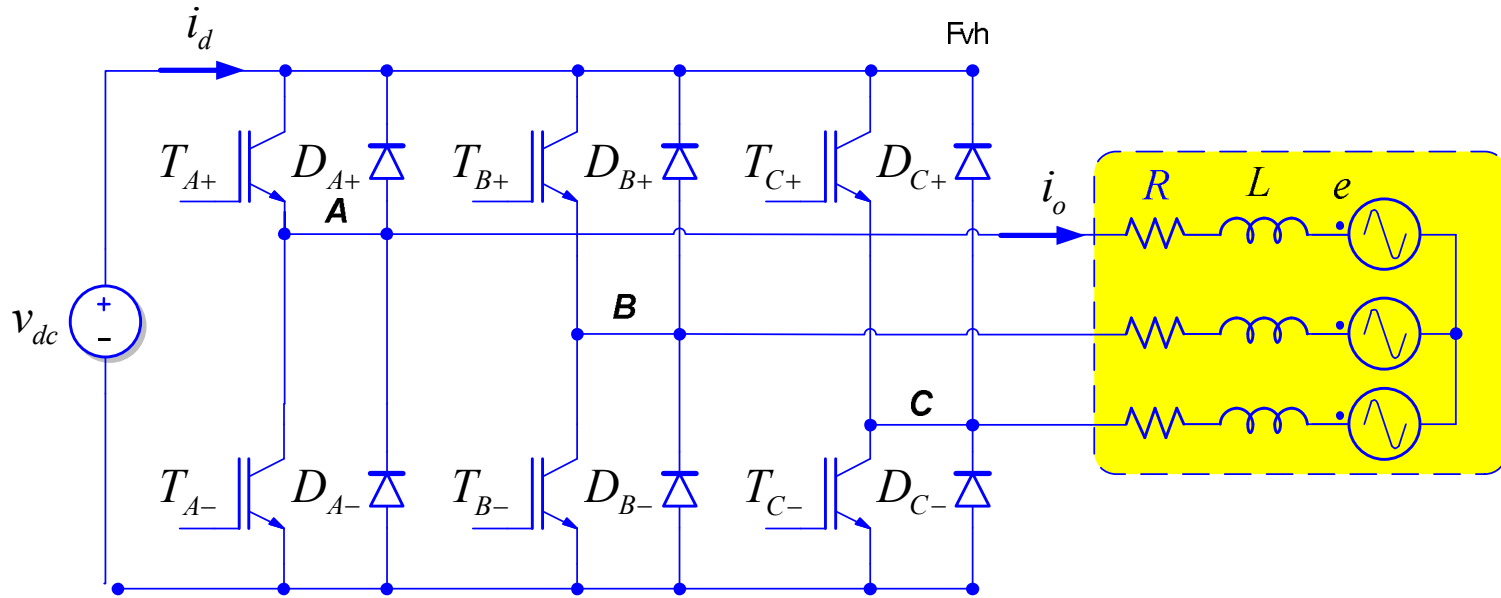

Three-Phase, Two-Level Voltage Source Converter Topology

DG Inverter Short Circuit Characteristics

Carrier and Modulating Signals

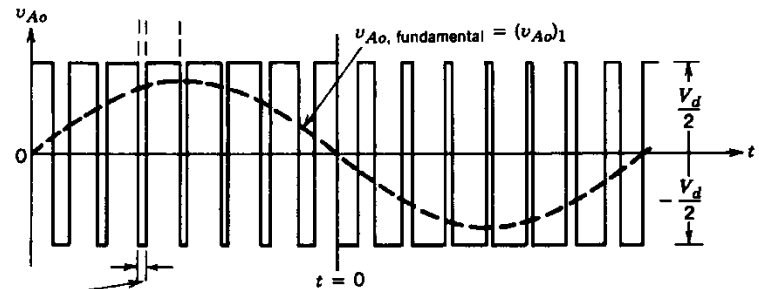
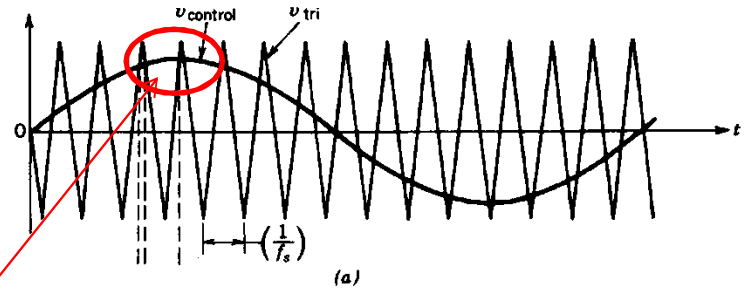
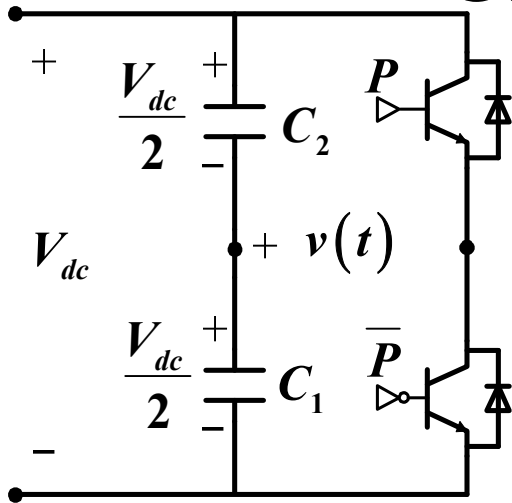

$v_{control} < v_{tri}$
 $\{ \therefore \text{on, } T_{A+}: \text{off} \}$

$v_{control} > v_{tri}$
 $\{ T_{A+}: \text{on, } T_{A-}: \text{off} \}$

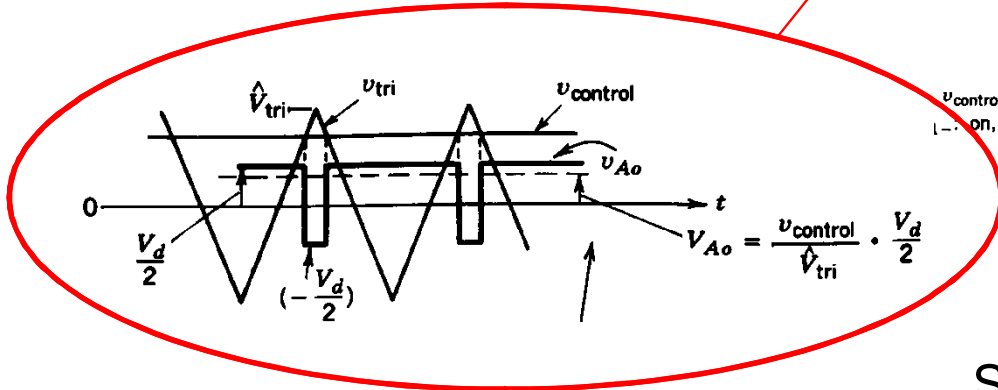

Sinusoidal Pulse Width Modulation

DG Inverter Short Circuit Characteristics

- Modulating signals are generated from AC Current Regulator
- i_d^* and i_q^* are real and reactive current commands
- High PI gains cause inverter to behave as stiff current source

Characteristics

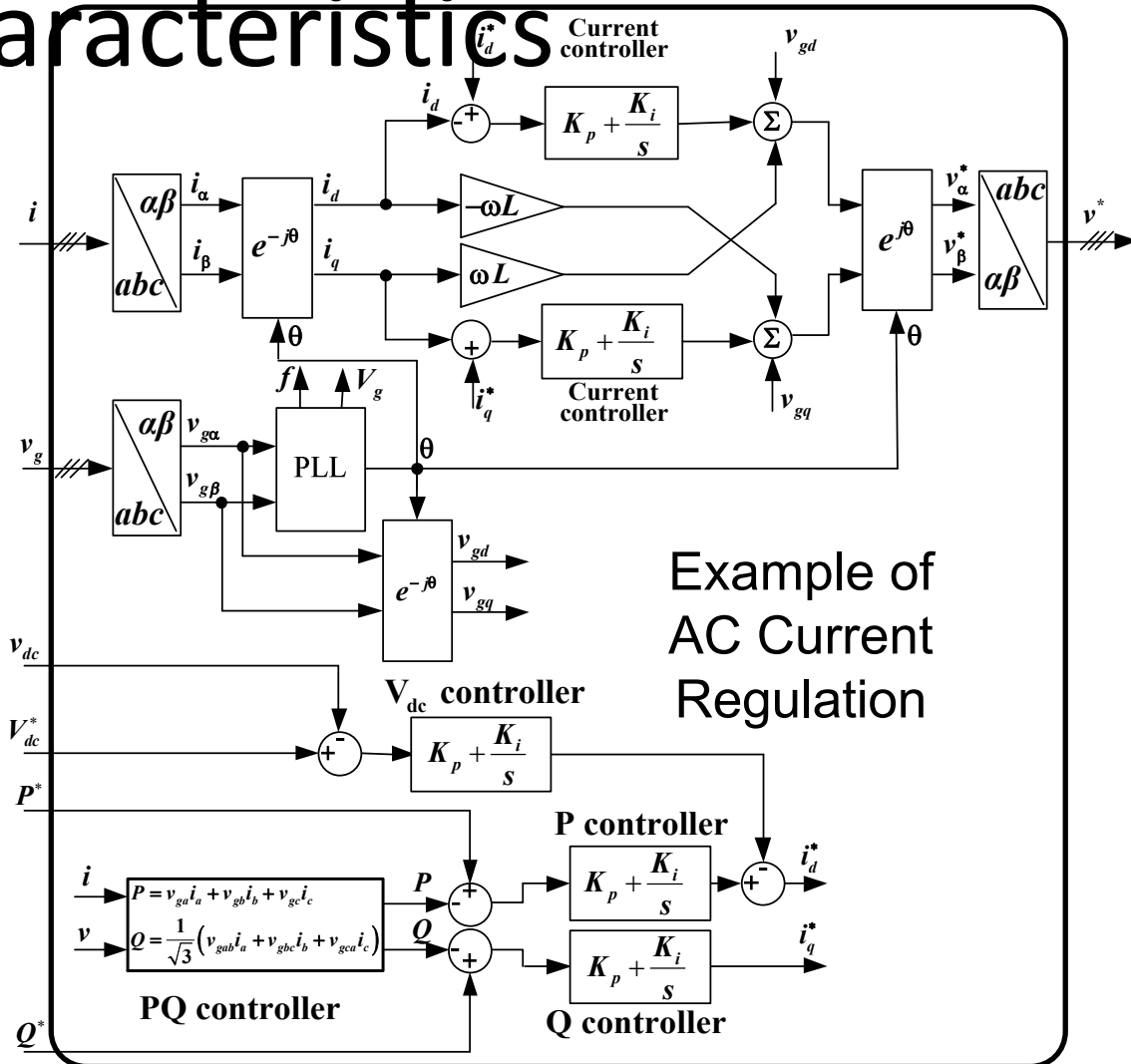

Example of AC Current Regulation



DG Inverter Short Circuit

Characteristics

- AC current regulator continues to regulate (and limit) current during fault
- X''_d , X'_d , X_d , X_2 are only meaningful for a single inverter operating point and one single fault location!
- Danger! : Underestimation of fault current contribution is possible with Thevenin representation when impedance is not changed to adapt to fault location
- Line synchronization technique (e.g., PLL implementation) has great impact on unbalanced fault response

DG Inverter Short Circuit Characteristics

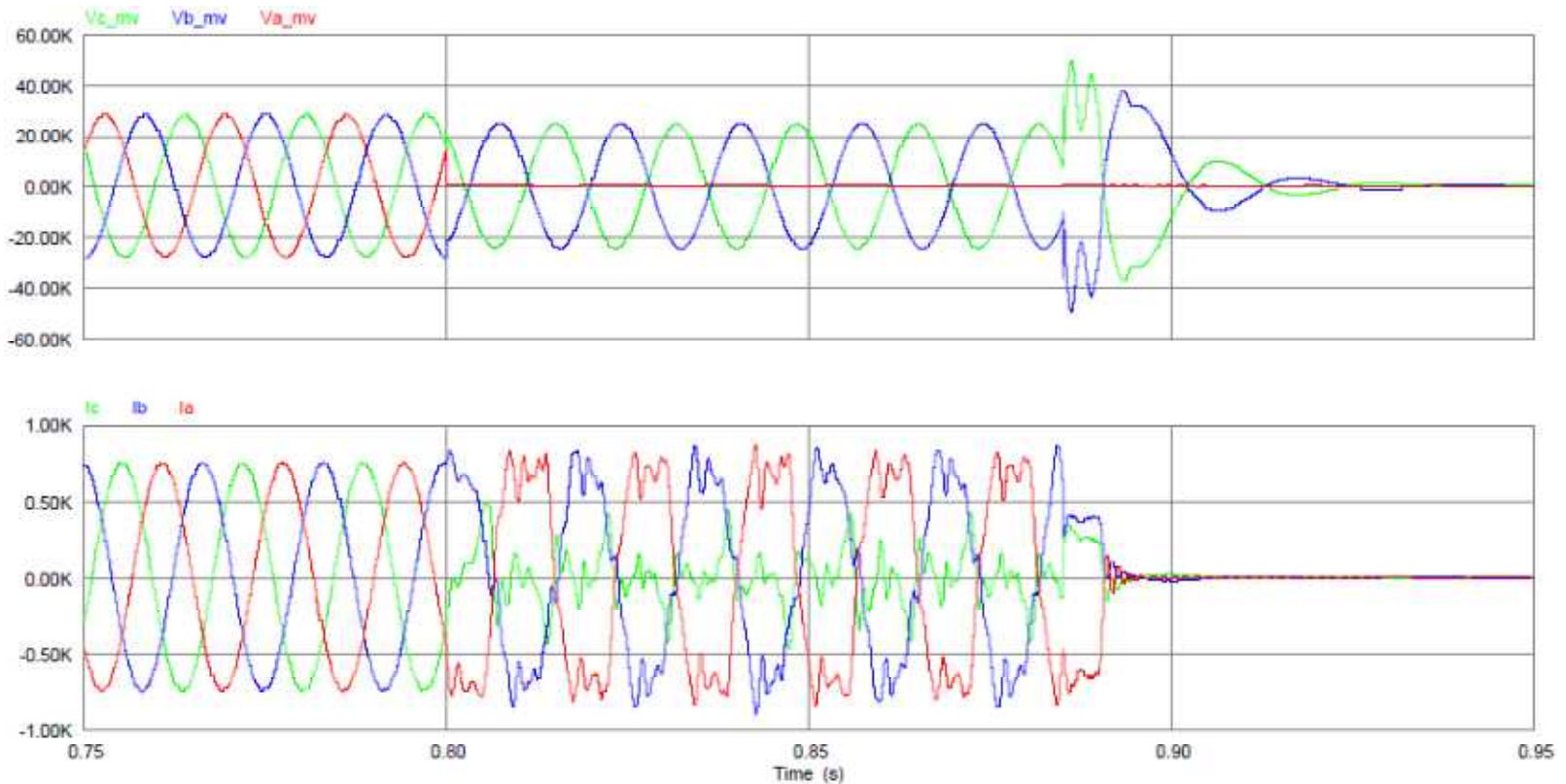

DG Inverter Short Circuit Characteristics

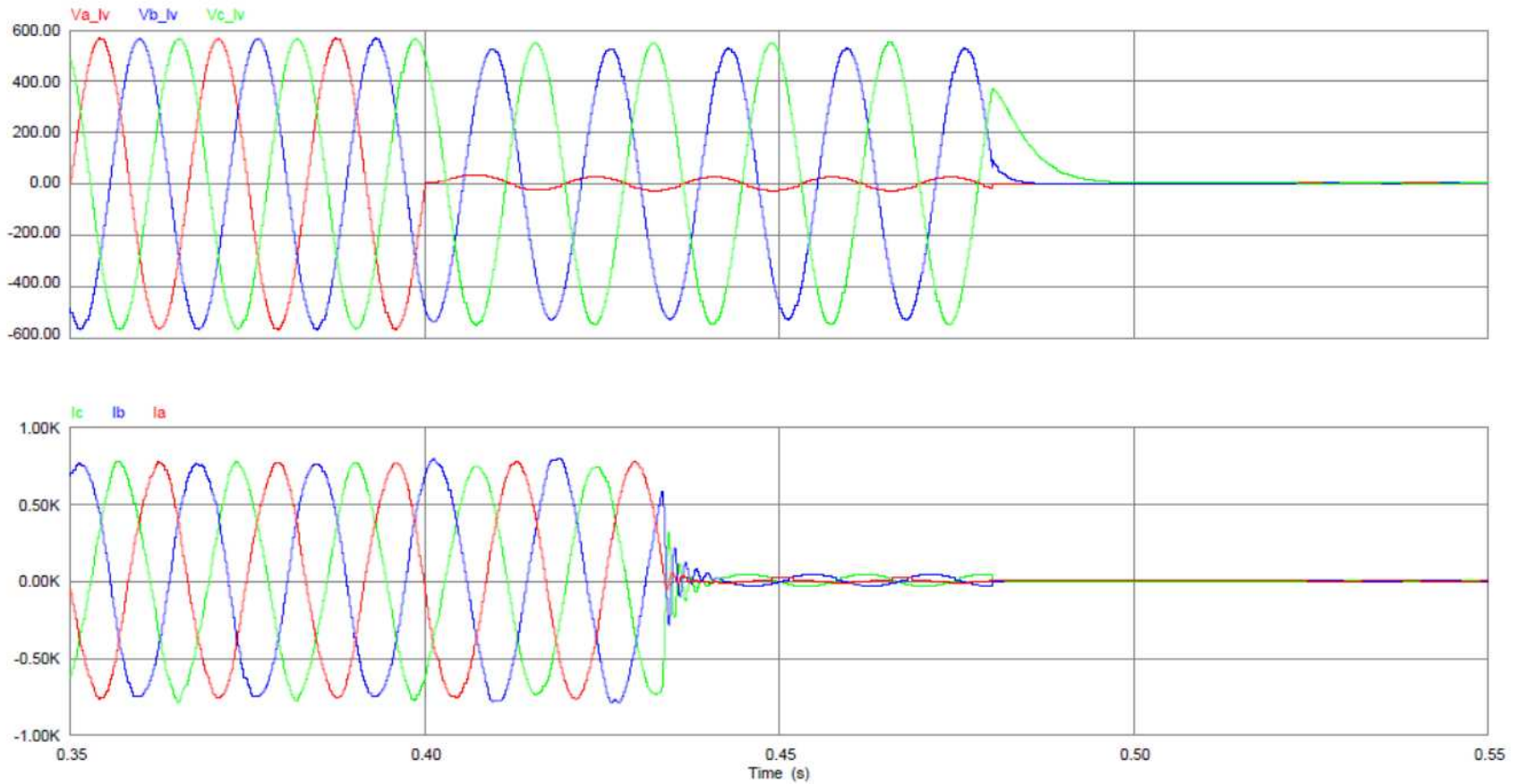



Status of Commercial Analysis Tools

- Disclaimer: these comments are general in nature are not directed at any particular software vendors' products
- Approaches to modeling current-regulated inverters:
 1. None (far most common)
 - No option for user but Thevenin generator model
 - What to do?
 - a. For balanced faults, use $X'' = I_{sc}$ (**Careful !!!**), or
 - b. Manually iterate Thevenin impedance, voltage or both to achieve I_{sc}
 - c. For unbalanced faults?
 2. Iterative solution
 - Automates manual process above, can work well for balanced faults
 - Provide user means to scale negative sequence current relative to positive sequence current (but without user guidance) for unbalanced faults

OK for one generator, but for dozens?



Conclusions

- Inability to properly model inverter-based generation in utility industry tools will drive penetration limits as utilities feel increasingly exposed on system protection issues
- No relevant industry standards (IEEE, ANSI, IEC) currently exist
- Commercial software packages are based on inapt Thevenin generator models (though some vendors are making initial attempts at more suitable representation in an